



PLATINUM

3.5QT. DIGITAL OIL-FREE AIR FRYER

MODEL: EAF-1506D(A~Z)

INSTRUCTION MANUAL

Before operating your new appliance, please read all instructions carefully and keep for future reference.



Questions? Elite's customer service team is ready to help.
Call us toll-free at 800-365-6133 ext. 120/107/105.

For more Elite products, visit us at www.maxi-matic.com or email us at info@maxi-matic.com.

TABLE OF CONTENTS

IMPORTANT SAFEGUARDS	2
INTRODUCTION	4
SHORT CORD PURPOSE AND POLARIZED PLUG WARNING	4
PARTS IDENTIFICATION	5
HOW TO USE THE TOUCH SCREEN PANEL	6
QUICK MENU CHART	7
PREPARING YOUR AIR FRYER FOR USE	7
HOW TO USE YOUR AIR FRYER	8
CLEANING & MAINTENANCE	11
COOKING TIME CHART	12
HINTS & TIPS	13
TROUBLESHOOTING	14
WARRANTY & CUSTOMER SERVICE	16

IMPORTANT SAFEGUARDS

The Elite Brand takes consumer safety very seriously. Products are designed and manufactured with our valued consumers' safety in mind. Additionally, we ask that you exercise a level of caution when using any electrical appliance by following all instructions and important safeguards.

READ ALL INSTRUCTIONS BEFORE USE AND SAVE FOR FUTURE REFERENCE

When using electrical appliances, basic safety precautions should always be followed, including the following:

Danger

1. Never immerse the power cord, plug or housing in water or under the tap.
2. Make sure no liquid enters the appliance to prevent electric shock or short-circuit.
3. Do not cover the air inlet and outlet of the appliance during operation.
4. Always place foods to be cooked in the basket, foods should never come into direct contact with the heating elements.
5. Never fill the pan with oil as this may cause a fire hazard and damage to the appliance.
6. Never touch the inside of the appliance during operation (pan, basket, etc.)

Warning

7. Make sure that your output voltage corresponds to the voltage stated on the rating label of the appliance.
8. If the supply cord is damaged, it must be replaced by a special cord or assembly available from the manufacture or its service agent.
9. It is recommended to regularly inspect the appliance to avoid a hazard. Do not operate any appliance with a damaged cord or plug or after the appliance malfunctions or has been damaged in any manner. Return appliance to the nearest authorized service facility for examination, repair, or adjustment.
10. Never attempt to repair the appliance yourself, otherwise the warranty becomes invalid.
11. This appliance is not intended for use by persons (including children) with reduced physical, sensory or mental capabilities, or lack of experience and knowledge, unless they have been given supervision or instruction concerning use of the appliance by a person responsible for their safety.
12. Close supervision is necessary when appliance is used near children.
13. NEVER ALLOW A CHILD TO USE THIS PRODUCT.
14. DO NOT let the power cord hang over the edge of the table or work-top, and keep it away from any hot surfaces.
15. Do not plug in the appliance or operate the control panel with wet hands.
16. Do not place or use the appliance on or near combustible materials, such as a tablecloth, curtains or wallpaper.
17. Only connect the appliance to a grounded wall socket. Always make sure that the plug is inserted into the wall socket properly.
18. Never connect this appliance to an external timer switch in order to avoid a hazardous situation.
19. Never leave appliance unattended.

IMPORTANT SAFEGUARDS (cont.)

20. Appliance surfaces may become hot during use.
21. The appliance should be placed on a horizontal and stable surface when using. Do not place on plastics, board or any other easy-wear surface.
22. Do not place the appliance against wall or other appliances, leave around 4 inches of space from nearby objects. Do not place anything on the top of appliance.
23. Do not use the appliance beyond the specification of this manual.
24. During operation, hot steam will exhaust through the hind side air outlet. Keep your hands and face at a safe distance from the steam and the air outlet openings. Also be careful of hot steam and air when you remove the pan from the appliance.
25. If food burns and dark smoke releases from the air outlet, unplug immediately and wait for smoke release to stop, then clean the food and oil from the pan and basket.

Caution

26. After use, turn off power to the appliance then unplug from the wall outlet.
27. Unplug the appliance from outlet when it is not in use or before cleaning. Allow it to cool down first before cleaning.
28. Do not use any accessories that have not been provided with the appliance.
29. This appliance is intended to be used indoors. Do not use outdoors.
30. Clean and wipe and dry the pan and the basket before placing food inside.
31. Do not power on the Air Fryer when the Top Lid is open.
32. Always unplug the appliance when not in use.
33. If the appliance is of the grounded type, the extension cord should be a grounded cord.
34. To ensure continued protection against risk of electric shock, connect to properly grounded outlets only.
35. Some countertop and table surfaces, such as Corian®, wood and / or laminates, are not designed to withstand prolonged heat generated by certain appliances. It is recommended by countertop manufacturers and Maxi-Matic that a hot pad or trivet be placed under your appliance to prevent possible damage to the surface.

**SAVE THESE INSTRUCTIONS
THIS PRODUCT IS FOR
HOUSEHOLD USE ONLY**

INTRODUCTION

Thank you for purchasing the Elite Platinum *Digital Air Fryer*. Your new *Digital Air Fryer* has a variety of functions to handle a wide array of cooking tasks. With its easy to use digital touch screen display and 6 Quick Menu functions, you can fry, cook, or even bake your favorite meals and snacks with ease! Best of all you will be cooking healthier without the addition of oil. Not only can you cook foods without the mess of oil but you can cook faster which saves you time and energy. Unlike most conventional deep fryers, the *Digital Air Fryer's* unique vapor system combined with circulating hot air will automatically make foods crispier and of course healthier without oil. We hope you enjoy your new Elite Platinum *Digital Air Fryer* and start cooking healthier today!

SHORT CORD PURPOSE

NOTE: A short power cord is provided to reduce the risk of personal injury resulting from becoming entangled in or tripping over a longer cord.

Longer power-supply cords or extension cords are available and may be used if care is exercised in their use.

If an extension cord is used: (1) the marked electrical rating of the extension cord should be at least as great as the electrical rating of the product; (2) the extension cord should be arranged so that it will not drape over the countertop or tabletop where it can unintentionally be pulled on or tripped over by children or pets.

POLARIZED PLUG

If this appliance is equipped with a **polarized plug** (one blade is wider than the other), please follow the below instructions:

To reduce the risk of electrical shock, this plug is intended to fit into a polarized outlet only one way. If you are unable to fit the plug into the electrical outlet, try reversing the plug. If the plug still does not fit, contact a qualified electrician. Never use the plug with an extension cord unless the plug can be fully inserted into the extension cord. Do not alter the plug of the product or any extension cord being used with this product. Do not attempt to defeat the safety purpose of the polarized plug.

PARTS IDENTIFICATION

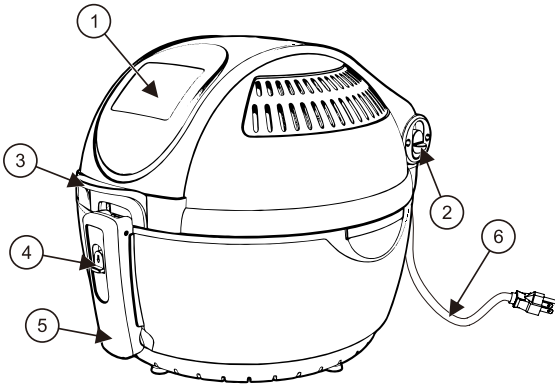

- 1) Touch Screen
- 2) Lid Release Switch
- 3) Lid Handle
- 4) Basket Fold-Down Switch
- 5) Basket Handle
- 6) Power Cord
- 7) Heating Elements
- 8) Safety Switch
- 9) Top Cover
- 10) Main Base
- 11) Pan Handle
- 12) Pan
- 13) Basket
- 14) Handle Bracket

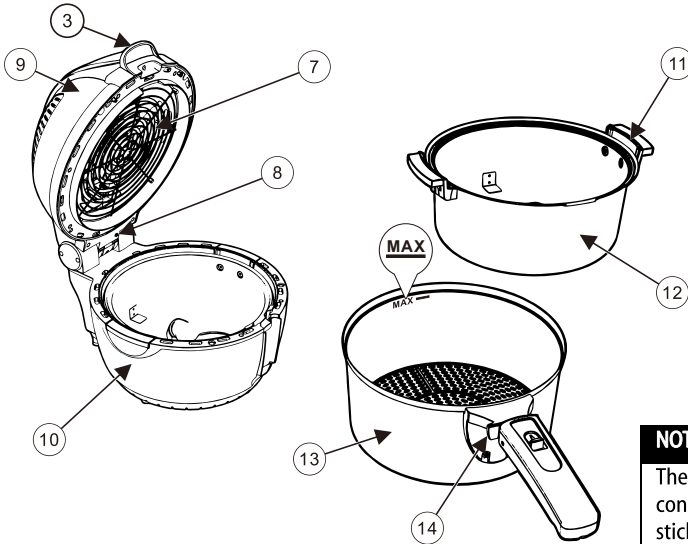

NOTE

The Basket (13) consists of a non-stick surface. To avoid scratching the non-stick surface, please use wooden or plastic utensils.

HOW TO USE THE TOUCH SCREEN PANEL

Your Digital Air Fryer features a Touch Screen Panel. Use your finger to lightly touch/press/tap the buttons on your fryer when making selections. It is not recommended or necessary to push down with excessive force on the buttons as this may lead to damaging the control panel of your fryer.

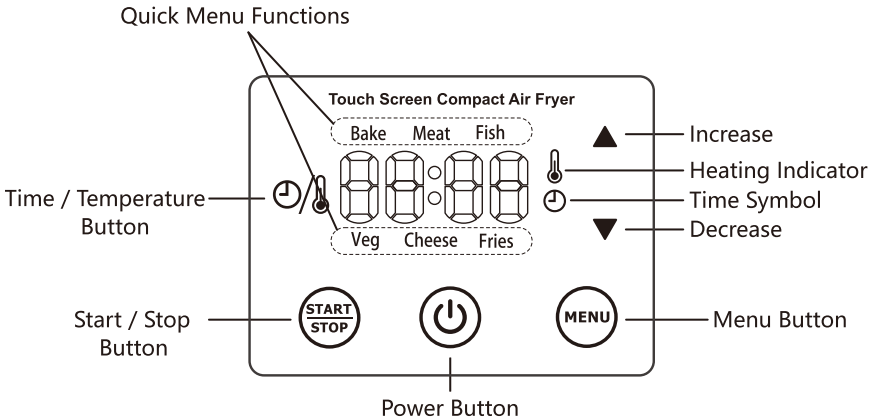

POWER BUTTON: Powers the *Digital Air Fryer* ON/OFF.

START/STOP BUTTON: Starts or Cancels selected cooking function.

MENU BUTTON: Use this button to cycle through and select a QUICK MENU function - The arrow on the display will point to the selected function - Bake, Meat, Fish, Fries, Cheese, Veg (Vegetables).

TIME/TEMP BUTTON: Use this button to toggle between adjusting Cook Time (from 1 minute up to 60 minutes) and Temperature (from 149°F up to 400°F).

▲ ▼ BUTTON: Use these buttons to increase/decrease the Time and/or Temperature settings.

HEATING INDICATOR: This icon will illuminate when the Air Fryer is heating.

QUICK MENU CHART

Menu	Default Temperature	Default Cook Time	Recommended Cooking Temperature Range	Recommended Cooking Time Range
BAKE	320°F	20 min	320°F ~ 392°F 1°F increments	10 ~ 20min 1 min increments
MEAT	400°F	20 min	375°F ~ 400°F 1°F increments	10 ~ 20min 1 min increments
FISH	392°F	10 min	350°F ~ 392°F 1°F increments	10 ~ 20min 1 min increments
FRIES	392°F	25 min	350°F ~ 392°F 1°F increments	15 ~ 25min 1 min increments
CHEESE	356°F	10 min	356°F ~ 375°F 1°F increments	10 ~ 15min 1 min increments
VEG (VEGETABLES)	320°F	10 min	320°F ~ 375°F 1°F increments	10 ~ 20min 1 min increments

PREPARING YOUR AIR FRYER FOR USE

- Before using your **Digital Air Fryer** for the first time, carefully remove all packaging material.
- Remove the parts from the box and wash the Pan (12) and Basket (13) with warm, soapy water and a non-abrasive sponge.

IMPORTANT: DO NOT IMMERSE THE MAIN HOUSING IN WATER. Wipe the interior and exterior of appliance clean with a damp cloth.

IMPORTANT: THIS IS NOT A DEEP FRYER. DO NOT FILL THE APPLIANCE OR ITS PAN (12) WITH OIL OR FRYING FAT.

- Place the appliance on a flat, horizontal and stable surface (make sure surface is heat-resistant). Place away from walls and other appliances. Leave approximately 4 inches of space from nearby objects. (See Figure 1)

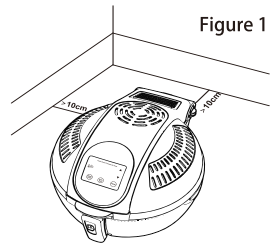

- Lift the Lid Handle (3) and open the Top Cover (9) to the position shown in Figure 2. The Top Cover (9) will remain open and locked into place. Grasp Basket Handle (5) to lift out Basket (13). (See Figure 2)

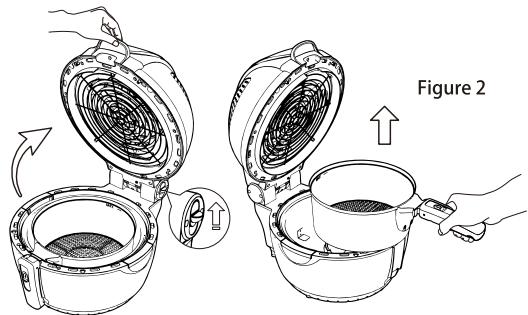

TIP: Never place food directly into the Pan (12). In place of using the Basket (13), an oven-safe plate or bowl (not included) can be placed onto a wire rack (not included) into the Pan (12).

HOW TO USE YOUR AIR FRYER

1. Make sure the Pan (12) is properly inserted into the Main Base (10) of the unit.
2. Place ingredients into Basket (13) and place Basket (13) into the Pan (12). (See Figure 3)

TIP: -Do not press the Basket Fold-Down Switch (4) when placing the Basket (13) into the Pan (12).
-Do not fill the Basket (13) over the MAX fill position.
-If cooking food that expands, make sure the cooked capacity will not exceed the MAX fill position.

3. To close the Top Cover (9), hold the Lid Handle (3) with one hand and use your other hand to push down on the Lid Release Switch (2). Slowly lower the Top Cover (9) down until it fully closes. (See Figure 4)

TIP: Always be sure to have a firm hold on the Lid Handle (3) before pressing the Lid Release Switch (2). Do not allow Top Cover (9) to forcefully drop down onto Main Base (10).

CAUTION: Do not touch the pan(12) during and immediately after use as it gets very hot. Only hold the pan by the handles(11).

NOTE: The initial 15 minutes of use may result in minimal smell and smoke. This is normal and harmless and comes from the protective substance applied to the heating elements during manufacturing.

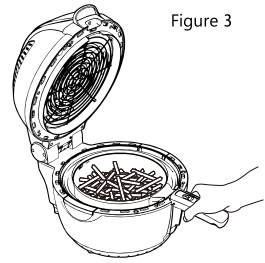

Figure 3

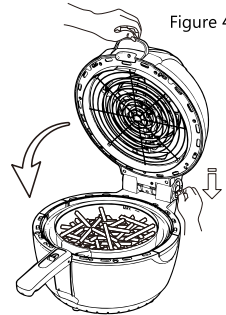

Figure 4

HOW TO MANUALLY PROGRAM FRYING TIME AND TEMPERATURE:

1. Plug Power Cord (6) into an electrical outlet. The appliance will be in standby mode.
2. Tap the POWER button.
3. Tap the TIME/TEMP button, the display will flash the default time of 25 minutes. Use the INCREASE/DECREASE buttons to program the air frying time. Hold down the INCREASE or DECREASE button for rapid increase/decrease of time.
4. Once you have selected your air fry time, touch the TIME/TEMP button again and the display will flash the default temperature of 400°F.
5. Use the INCREASE/DECREASE buttons to program the air frying temperature. Hold down the INCREASE or DECREASE button for rapid increase/decrease of temperature.
6. Once you have selected your air frying temperature, tap START.

TIP: It is recommended to pre-heat the air fryer on empty for 3 min. if the appliance is cold.

HOW TO USE YOUR AIR FRYER (cont.)

HOW TO SELECT A QUICK MENU FUNCTION:

1. Plug Power Cord (6) into an electrical outlet. The appliance will be in standby mode.
2. Tap the POWER button.
3. Tap the MENU button and the 6 Quick Menu functions will appear on the display. Keep tapping the MENU button until you've reached the desired Quick Menu function. It will begin flashing.

NOTE: Each Quick Menu function is pre-programmed with a default time and temperature (please reference QUICK MENU CHART on page 7).

1. To manually adjust the Times and Temperatures for each Quick Menu function, tap the TIME/TEMP button while the Quick Menu function is flashing.
2. The display will flash the default air fry time. Use the INCREASE/DECREASE buttons to adjust the time up or down. Hold down for rapid increase/decrease of time.
3. Once you have selected your air fry time, tap the TIME/TEMP button again and the display will flash the default temperature.
4. Use the INCREASE/DECREASE buttons to adjust the temperature up or down. Hold for rapid increase/decrease of temperature.

NOTE: Please reference the QUICK MENU CHART on page 7, for the recommended ranges of time and temperature for each Quick Menu function.

Once you have selected your air fry temperature tap START.

TIP: It is recommended to pre-heat the air fryer on empty for 3 min. if the appliance is cold.

DURING THE COOKING/FRYING PROCESS:

1. Once you tap START, the Timer will begin counting down and the Heating Indicator will illuminate red.

NOTE: You will notice that during the hot air frying process, the Heating Indicator will come on and go out from time to time. This indicates that the heating element is maintaining the set temperature.

NOTE: Any excess oil from food will collect at the bottom of the Pan (12).

TIP: During cooking, tap the TIME/TEMP button and the INCREASE/DECREASE buttons to manually adjust the cooking temperature and time. TAP START to resume cooking.

2. Some recipes require stirring/mixing the contents mid-way through cooking (see Cooking Time Chart on page 12). You can do this in the middle of the cooking process by first pressing the STOP button. To stir the ingredients, grasp the Lid Handle (3) and lift to open. Allow the Top Cover (9) to click and lock into position and remain open on its own. Grasp the Basket Handle (5) and lift out of fryer. Shake or stir the contents of the basket using a non-metallic utensil and then place Basket (13) back into the Pan (12).

TIP: If you set the timer to half the required cook time, you will hear the timer indicator when you have to stir the ingredients. However, this means that you will need to set the timer again to the remaining cook time after stirring.

3. To resume the air frying process, tap START.

HOW TO USE YOUR AIR FRYER (cont.)

TIP: After you tap STOP, if you do not resume cooking by tapping START within 3 minutes, the unit will automatically turn off and go into standby mode.

CAUTION: During cooking, the Pan (12) and Basket (13) will be very hot, only use the cool-touch handles or oven mitts.

WHEN COOKING/FRYING IS COMPLETE:

1. When the timer completes its countdown, the air fryer will beep and stop heating - this signals it is time to remove your food. (Please note that the fan motor will continue to operate in order to cool down the Pan (12) and the Basket (13), this will stop within approximately 30 seconds).

NOTE: You can also switch off the appliance manually by tapping STOP at any time during the cooking process.

2. Open the Top Cover (9) and allow it to click and lock into position and remain open on its own. Grasp the Basket Handle (5) and lift out of the fryer. Place it onto a flat, heat-resistant surface. (See Figure 5)

CAUTION: When opening the Top Cover (9), be careful of hot air and steam. Keep hands and face away from the opening.

CAUTION: After cooking, the Pan (12) and Basket (13) will be extremely hot to the touch. Do not touch surfaces of the Pan (12) or Basket (13) directly.

3. Check that your foods are ready. If not, then place the Basket (13) back into the Pan (12) and set the timer for a few more minutes.
4. Empty the contents of the Basket (13) into a bowl or onto a plate (See Figure 6). If necessary, you can also use Tongs to remove foods from the Basket (13).

CAUTION: Do not press the Basket Fold-Down Switch (4) while holding the Basket (13). (See Figure 7)

TIP: If food contents within Basket (13) are too heavy to lift using the Basket Handle (5), use oven mitts to lift out the Pan (12) and Basket (13) together by grasping the Pan Handles (11). Place on a flat, heat-resistant surface and use Tongs to remove contents from the Basket (13).

TIP: Do not turn the Basket (13) and Pan (12) upside down together, as any excess oil that has collected in the bottom of the Pan (12) will be poured onto the foods.

5. When the next batch of ingredients is ready, the air fryer is instantly ready to use again.
6. When cooking is complete, tap the POWER button to shut down and remove the Power cord (6) from the electrical outlet (See Figure 8).

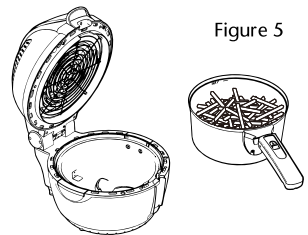

Figure 5

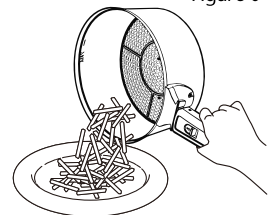

Figure 6

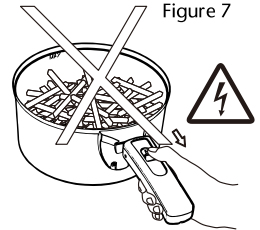

Figure 7

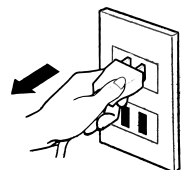

Figure 8

CLEANING AND MAINTENANCE

The **Digital Air Fryer** should be cleaned thoroughly after every use.

1. Make sure the Power cord (6) is disconnected from the electrical outlet and that the appliance has cooled down before attempting to clean.
2. The Pan (12), Basket (13) and the inside of the appliance have a nonstick coating. Do not use metal utensils or abrasive cleaning materials on them, as this can damage the non-stick coating.
3. Wipe the outside of the appliance with a damp cloth.
CAUTION: *Do not allow water to seep into the LED control panel as that may damage the appliance.*
4. Clean the Pan (12) and Basket (13) with hot water, dishwashing soap and a non-abrasive sponge.
5. You can use a degreaser to remove any stuck-on residue.
NOTE: *The Pan (12) and Basket (13) are dishwasher-safe (top rack only).*
TIP: *If food residue is stuck to the Basket (13) or the bottom of the Pan (12), place the Basket (13) into the Pan (12) and fill with dishwashing soap and water and let soak for 10 minutes.*
6. Clean the inside of the appliance with hot water and a non-abrasive sponge.
7. Never immerse the power cord, plug or the appliance body in water or any other liquids.
8. Dry all parts after each use, re-assemble and store in a cool, dry location.

COOKING TIME CHART

The chart on this page helps you to program basic times and temperatures for common foods.

Please note that all of the information below is for your reference only and can be adjusted according to the user's preference. They are approximations only as foods differ in size and density so cooking times and temperatures cannot be guaranteed.

	Min-max Amount (ounces)	Time (min.)	Temp (°F)	Stir	Notes
Potatoes & fries					
Thin frozen fries	15 ~ 25	11-16	392	Stir	
Thick frozen fries	15 ~ 25	13-20	392	Stir	
Home-made fries (0.3" x 0.3")	15 ~ 30	15-20	392	Stir	add 1/2 tbsp of oil
Home-made potato wedges	15 ~ 30	20-22	356	Stir	add 1/2 tbsp of oil
Home-made potato cubes	15 ~ 25	14-18	356	Stir	add 1/2 tbsp of oil
Home-made potato chips	10	9-10	320		
Meat & Poultry					
Steak	6 ~ 18	9-12	356		
Pork chops	6 ~ 18	11-14	356		
Hamburger	6 ~ 18	8-14	356		
Drumsticks	6 ~ 18	19-22	356		
Chicken Wings	15 ~ 20	16-18	392		
Chicken Strips	6 ~ 18	12-15	356		
Snacks					
Egg rolls	6 ~ 18	9-10	392	Stir	Use oven-ready
Frozen chicken nuggets	6 ~ 18	7-10	392	Stir	Use oven-ready
Frozen fish sticks	6 ~ 14	7-10	392		Use oven-ready
Fish fillet in batter	6 ~ 18	8-14	356	Stir	
Battered shrimp	6 ~ 18	8-13	356	Stir	
Frozen breadcrumbed cheese sticks	6 ~ 14	9-10	356		Use oven-ready
Stuffed vegetables	6 ~ 14	10	320		
Mushrooms	6 ~ 14	10	320		
Onion Rings	6 ~ 18	8-13	356		
Baking					
Cake	10	20-25	320		Use oven-safe baking dish (not included)
Quiche	15	20-22	356		Use oven-safe baking dish (not included)
Muffins	10	15-18	392		Use oven-safe muffin cups (not included)
Sweet snacks	15	20	320		Use oven-safe baking dish (not included)

HINTS & TIPS

TIPS

- Smaller cuts of foods usually require a slightly shorter cooking time than larger foods.
- A larger amount of foods only requires a slightly longer cooking time and a smaller amount of foods only requires a slightly shorter cooking time.
- Stirring or shaking smaller foods mid-way through the cooking process will improve the end result and can help cook more evenly.
- Adding a small amount of oil to fresh potatoes can result in a crispier result. Cook your ingredients in the air fryer within a few minutes after adding the oil.
- Do not air fry extremely greasy foods such as sausages in the air fryer.
- Snacks that can be prepared in an oven can also be prepared in the air fryer.
- The optimum amount for air frying crispy fries is 17.5 ounces or a little over 1 lb.
- Use pre-made dough to prepare foods with fillings quickly and easily. Pre-made dough also requires a shorter cooking time than home-made dough.
- The air fryer can also reheat foods. To reheat foods, set the temperature to 300°F for up to 10 minutes.
- To cook frozen foods, add an additional 3-5 minutes to your cook time.

Note: When cooking/baking foods that rise (i.e. cakes, quiches or muffins) the Basket (13) should not be filled more than halfway.

Note: Add 3 minutes to the cooking time if you begin cooking while the air fryer is still cold.

BAKING CAKES/QUICHES OR STEAMING FOODS

- Place an oven-safe dish (not included) into the air fryer Basket (13) if you want to bake a cake/quiche, steam foods or if you want to air fry delicate foods or foods with fillings.
- If the oven-safe dish is too large for the Basket (13), you can place a wire rack (not included) onto the bottom of the Pan (12) and place the oven-safe dish onto the wire rack.
- For steaming foods, generally, 1-2 cups of water provides approximately 5-10 minutes of steam time. Add water to the Pan (12). Place wire rack (not included) into the Pan (12). Place food into an oven-safe dish (not included) and place dish onto the wire rack.

HOME-MADE FRENCH FRIES

When making your own french fries, follow these steps:

1. Peel potatoes and slice them into strips.
2. Wash and dry them thoroughly.
3. Mix potato strips in a bowl with ½ tablespoon of olive oil, make sure they are evenly coated.
4. Using your hands or tongs, place the potato strips into the frying Basket (13).
NOTE: Do not pour the potato sticks from the bowl into the Basket (13) because we don't want to transfer any excess oil into the Basket (13).

TROUBLESHOOTING GUIDE

Problem	Possible cause	Solution
The airfryer does not work.	The appliance is not plugged in.	Plug the power cord (6) into an electrical outlet.
		You did not tap START button.
	The appliance is defective.	Contact customer service at 800-365-6133 ext. 120/107/105
Air fryer keeps returning to standby mode while you are trying to program time/temperature.	During time/temperature selection process, if START button is not pressed within 3 minutes, the unit will automatically turn off and go into standby mode.	Do not wait more than 3 minutes after making your selections to tap START button.
Food not completely cooked/fried.	There is too much food in the basket (13).	Use smaller batches of food in the basket (13). Small batches of food will cook more evenly.
	The cooking temperature is set too low.	Increase the temperature setting. Check "Cooking Time Chart" found in this manual.
	The cooking time is too short.	Increase the time setting. Check "Cooking Time Chart" found in this manual.
Food cooked is uneven.	Certain foods need to be stirred/mixed mid-way through the cooking process.	Foods that overlap inside the basket (13) need to be stirred mid-way through cooking. Go to section: 'During the Cooking/Frying Process' in this manual.
Fried snacks are not crispy.	You used a type of snacks meant to be prepared in a traditional deep fryer.	Use oven snacks or lightly brush some oil onto the snacks for a crispier result.
I cannot close the Top Cover (9) properly.	The basket (13) is too full.	Do not fill the basket (13) above the MAX level.
	The basket (13) is not aligned correctly.	Make sure the handle bracket (14) is flush with the pan (12).
	The pan (12) is not properly placed into air fryer.	Make sure pan handles (11) are not blocking the top cover (9).
White smoke is emitted out of the appliance during use.	You are preparing food with a high oil content.	When cooking with oily foods, oil will drain into the pan (12). When the air fryer heats up, the pan heats up the oil and produces white smoke. This does not adversely affect the air fryer or your cooking process.
	The pan has built-up oil residue from previous uses.	White smoke is caused by oil leftover in the pan (12). Make sure to thoroughly clean the pan (12) after every use.
Home-made french fries are coming out unevenly cooked.	Your potatoes are not fresh or are frozen.	Make sure to use fresh and firm potatoes. Not frozen potatoes for home-made french fries.

	Potato strips were not thoroughly rinsed prior to frying.	Thoroughly rinse sliced potato to remove all starch prior to frying.
Your home-made french fries are not crispy after air frying.	Crispy results are directly linked to the amount of oil and water content of the fresh potato strips.	Potato strips need to be thoroughly dried before adding oil.
		Slice potato strips thinner if you want them crispier.
		Use a bit more oil on the potato strips prior to frying if you want crispier results.

LIMITED WARRANTY* ONE (1) YEAR
WARRANTY IS ONLY VALID WITH A DATED PROOF OF PURCHASE

PLEASE DO NOT RETURN TO STORE.

If you have any problems with this unit, contact Consumer Relations for service

1. Your small kitchen appliance is built with precision, inspected and tested before leaving our factory.
2. It is warranted to the original purchaser to be free from any manufacturing defects under normal use and conditions for one (1) year, cord excluded. This Warranty applies only to the original purchaser of this product.
3. Retail stores/merchants selling this product do not have the right to alter, modify, or in any way revise the terms and conditions of the warranty.
4. If you use your appliance for household use and according to instructions, it should give you years of satisfactory service.
5. At its sole discretion, Maxi-Matic USA will either repair or replace the product found to be defective during the warranty period.
6. The repaired or replacement product will be in warranty for the remaining balance of the one-year warranty period and an additional one-month period.
7. Consumer's remorse is not an acceptable reason to return a product to our Service Center.
8. **This limited warranty covers appliances purchased and used within the 50 U.S. states plus the District of Columbia and does NOT cover normal wear of parts or:**
 - Damages caused by unreasonable use, neglect, normal wear and tear, commercial use, improper assembly or installation of product.
 - Damages caused in shipping.
 - Damages caused by replacement or resetting of house fuses or circuit breakers.
 - Defects other than manufacturing defects.
 - Breakage caused by misuse, abuse, accident, alteration, lack of proper care and maintenance, or incorrect current or voltage.
 - Lost or missing parts of the product. Parts will need to be purchased separately.
 - Damages of parts that are not electrical; i.e. cracked or broken plastic/glass, scratched/dented inner pots.
 - Damage from service or repair by unauthorized personnel.
 - Extended warranties purchased via a separate company or reseller.
 - Acts of God such as fire, floods, hurricanes, tornadoes, etc.

Maxi-Matic, USA shall not be liable for any incidental or consequential damages caused by the breach of any express or implied warranty. Apart from the extent prohibited by applicable law, any implied warranty of merchantability or fitness for a particular purpose is limited in time to the duration of the warranty.

*One Year Limited Warranty valid only in the **50 U.S. states plus the District of Columbia, excluding** Puerto Rico and the Virgin Islands.

This warranty is effective only if the product is purchased and operated in the USA; product usage which is in violation of the written instructions provided with the unit will void this warranty.

For international warranty, please contact the local distributor.

This warranty gives you special legal rights and you may also have other rights to which you are entitled which may vary by state, province, and/or jurisdiction.

**Any instruction or policy included in this manual may be subject to change at any time.

MAXI-MATIC, USA

18401 E. Arenth Ave. City of Industry, CA 91748

Customer Support Hours of Operation MON-FRI 8:30 AM - 5:00 PM PST

(800) 365-6133 Ext: 120/107/105; (626) 912-9877 Ext: 120/107/105

Website: www.maxi-matic.com email: info@maxi-matic.com

RETURN INSTRUCTIONS

RETURNS:

- A. Any return of defective merchandise to the manufacturer must be processed accordingly by first contacting customer service (info@maxi-matic.com) to obtain an RA # (Return Authorization Number). We will not accept any returns of merchandise without an applicable RA #.
- B. **IMPORTANT RETURN INSTRUCTIONS.** Your Warranty depends on your following these instructions if you are returning the unit to Maxi-Matic, USA:
 1. Carefully pack the item in its original carton or other suitable box with sufficient cushioning to avoid damage in shipping.
 2. Before packing your unit for return, be sure to enclose:
 - a) Your name, full address with zip code, daytime telephone number, and RA#,
 - b) A dated sales receipt or **PROOF OF PURCHASE**,
 - c) The model number of the unit and the problem you are having (Enclose in an envelope and tape directly to the unit before the box is sealed,) and
 - d) Any parts or accessories related to the problem.
 3. Maxi-Matic, USA recommends that you ship the package via UPS ground service for tracking purposes. **We cannot assume responsibility for lost or damaged products returned to us during incoming shipment.** For your protection, always carefully package the product for shipment and insure it with the carrier. C.O.D shipments cannot be accepted.
 4. **All return shipping charges must be prepaid by you.**
 5. Mark the outside of your package:
MAXI-MATIC USA
18401 E. ARENTH AVE.
CITY OF INDUSTRY, CA 91748
 6. Once your return has been received by our warehouse, Maxi-Matic, USA will repair or replace the product if it is defective in material or workmanship, subject to the conditions in paragraph B.
 7. **Maxi-Matic will pay the shipping charges to ship the repaired or replacement product back to you.**



P L A T I N U M

Elite Customer Service Center

Mail: Maxi-Matic, USA
18401 E. Arenth Ave
City of Industry, CA
91748-1227

Phone: 800-365-6133 ext. 120/107/105

Email: info@maxi-matic.com

www.maxi-matic.com

Elite is a registered trademark of Maxi-Matic, USA.
Copyright Elite by Maxi-Matic.

Actual product may vary from the images/illustrations in this manual due to continual product improvement.

MODEL: EAF-1506D(A~Z)