



# Deluxe Outdoor

## Assembly & Operation

### Grill & Smoker 8500



Conforms to ANSI STD Z21.58b-2012  
OUTDOOR COOKING GAS APPLIANCES

**Intertek**



#### Tools needed for assembly:

Phillips screwdriver, Pliers or Adjustable Wrench

#### **DANGER**

If you smell gas:



1. Shut off gas to the appliance.
2. Extinguish any open flames.
3. Open lid.
4. If odor continues, keep away from the appliance and immediately call your fire department.

Failure to follow these instructions could result in fire or explosion which could cause property damage, personal injury or death.



#### **DANGER**

1. Never operate this appliance unattended.
2. Never operate this appliance within 10 ft (3.0 m) of any structure, combustible material or other gas cylinder.
3. Never operate this appliance within 25 ft (7.5 m) of any flammable liquid.
4. Do not fill cooking vessel beyond maximum fill-line.
5. Never allow oil or grease to get hotter than 400°F or 200°C. If the temperature exceeds 400°F (200°C) or if oil begins to smoke, immediately turn the burner or gas supply OFF.
6. Heated liquids remain at scalding temperatures long after the cooking process. Never touch cooking appliance until liquids have cooled to 115° F (45°C) or less.
7. If a fire should occur, keep away from the appliance and immediately call your fire department. Do not attempt to extinguish an oil or grease fire with water.

Failure to follow these instructions could result in fire or explosion which could cause property damage, personal injury or death.

 **WARNING** 



For Outdoor Use Only  
(outside of any type of enclosure)

 **DANGER** 

- Never use the gas or charcoal grill for INDOOR cooking or heating
- Never use the grill on or in a boat or recreational vehicle



The combustion fumes from either the gas or charcoal grill are toxic and can cause severe illness and possibly death.

**Step 15**



 **WARNING** 

If you smell gas –

- Turn off the gas supply to the appliance
- Extinguish any and all open flames
- Open the Lid of the Grill
- If the odor remains, stay away from the grill and notify your gas supplier and/or the Fire Department.



 **WARNING** 

The combustion of Propane gas can yield the formation of chemical compounds known in the state of California, U.S.A., to cause birth defects, cancer, and other serious health matters.

 **WARNING** 



- Do not use or store gasoline, kerosene, alcohol, or other flammable liquids or vapors in the vicinity of this appliance or any other appliance.
- Any LP Gas Cylinder NOT connected for use with the appliance, shall not be stored in the same vicinity of this or any other appliance.

A LP Propane Gas Cylinder is needed for operating the gas side of this grill.  
The LP Gas Cylinder is NOT included.  
This gas grill is only intended for Domestic use, not to be used for any commercial purpose.



 **WARNING** 

Read this installation manual before assembling or servicing this appliance.

Failure to follow these instructions may result in a faulty installation, which could cause damage to property, personal injuries or even death.

 **IMPORTANT** 

Save these instructions after reading them in case you need to refer to them in the future.

 **WARNING** 

**CALIFORNIA PROPOSITION 65**  
Combustion by-products produced when using this product contain chemicals known to the State of California to cause cancer, birth defects, and other reproductive harm.



***Read all safeguards and assembly instructions before assembling and operating your grill/smoker.***

***Before assembling your new grill/smoker, unpack all the parts from the box. Carefully remove all packing material and lay out all the parts for easy access and identification. Do not discard the carton or packaging until your smoker is fully assembled and operating to your satisfaction.***

***In order to properly assemble your smoker, you will only need two tools:***

- ***Phillips head screwdriver***
- ***Pliers or adjustable wrench (tools not included)***

***The grill/smoker is heavy and must be moved around during assembly and before use. Be sure to have a friend help.***

**Outdoor Leisure Products, Inc.  
5400 Doniphan Drive  
Neosho, MO 64850  
Toll Free: 866-475-5180  
Website: [www.olp-inc.com](http://www.olp-inc.com)**



**8:30am to 4:30pm, Central Time  
Monday through Friday**

## **SAFETY WARNINGS**

1. The installation of this grill must conform to local codes, or in the absence of local codes, with either the *National Fuel Gas Code, ANSI Z223.1 / NFPA 54, Natural Gas and Propane Installation Code, CSA B149.1, or Propane Storage and Handling Code, B 149.2, or The Standard for recreational Vehicles, ANSI 119.2 / NFPA, and CSA Z240 RV Series, Recreational Vehicle Code*, as Acceptable.
2. The Gas Grill side of the 8500 is for use with LP (Propane) Gas ONLY! LP Gas Cylinder is NOT included with the Grill.
3. Never use lighter fluid, gasoline, kerosene, or alcohol for lighting the gas grill.
4. The LP Gas supply Cylinder used must be constructed and marked in accordance with the *Specifications of the U.S. Department of Transportation (D.O.T.) or The Standard for Cylinders, Spheres and Tubes for Transportation of Dangerous Goods; and Commission, CAN/CSA-B339*, as applicable. It MUST be provided with a Listed Overfilling Device. Only use 20 pound cylinders that have a type 1 cylinder connection device compatible with the Connection for Outdoor Cooking Appliances.
5. The LP gas cylinder must be arranged for vapor withdrawal, purging and have an overfilling prevention device.
6. LP Gas Cylinders must be stored outdoors, out of the reach of children, and must not be stored in a building, garage or any other enclosed area.
7. The Pressure regulator and Hose Assembly supplied with the Grill, must be used. Any replacement regulator and hose assemblies must be those specified by the outdoor cooking gas appliance manufacturer.
8. The LP Gas Cylinder must include a collar to protect the cylinder valve.
9. Do not store a spare LP Gas Cylinder under or near this grill.
10. Never fill the LP Gas Cylinder beyond 80% full. For vapor withdrawal /purging, the cylinder should be in the upright position.
11. This outdoor cooking gas appliance must only be used outdoors, and must not be used in a building, garage or any enclosed area
12. The following distances for proper clearance must be maintained :
  - Minimum distance from back and sides of the outdoor cooking gas appliance to walls is 36" ( 1 meter )
  - Do not use under any overhead combustible constructions
  - For outdoor use only
  - Remove LP Gas Cylinder from grill if storing grill indoors
13. This outdoor cooking gas appliance is not intended to be installed in or on boats
14. Inspect the Gas Hose before each use. If the Hose has any leak, cut or wear, it must be replaced BEFORE using the grill
15. Do not try to move the grill while either gas, charcoal or smoker firebox is lit.
16. Wait one hour minimum before touching any metal parts, until they are cool.
17. NEVER leave the grill unattended when in use.
18. Keep children and pets away from the grill when in use.
19. Note: Grease Drip Trays and Grease Cup should be emptied and cleaned after each use to prevent flare – ups and /or grease fires.

**IF THESE INSTRUCTIONS ARE NOT FOLLOWED EXACTLY, A FIRE CAUSING DEATH OR SERIOUS INJURIES MAY OCCUR!**

**READ ALL SAFEGUARDS AND INSTRUCTIONS THOROUGHLY!**  
**YOUR SAFETY IS VERY IMPORTANT – FAILURE TO FOLLOW PROPER PROCEDURES AND SAFEGUARDS MAY RESULT IN PROPERTY DAMAGE, PERSONAL INJURY OR DEATH.**

 <b>DANGER</b>	<b>DANGER</b> 
<ul style="list-style-type: none"> <li>. The GRILL is for outdoor use only!</li> <li>. Do NOT use this grill for other than its intended purpose.</li> <li>. Do not leave grill unattended when in use.</li> <li>. Do not use gasoline, kerosene or alcohol for lighting charcoal, use of any of these or similar products may cause an explosion possibly leading to severe bodily harm.</li> <li>. Never operate this grill under any overhead roof covering, awning or overhang. Never use inside an enclosed area such as screen patios, garages, buildings or tents.</li> <li>. Keep the area clear of all flammable liquids, combustible material including but not limited to wood, dry plants including grass, brush, paper, and canvas.</li> <li>. Grill is HOT while in use and after use – Avoid touching hot surfaces. Always wear protective gloves or mitts when operating the smoker.</li> <li>. Keep children and pets away from the grill at all times.</li> <li>. Do not allow anyone to conduct activities around the grill during or following its use until the unit has cooled. The grill is hot during operation and remains hot for a period of time following its use.</li> <li>. Always wear shoes and protective clothing during operation of this smoker.</li> <li>. Never use glassware, plastic, or ceramic cookware in this grill.</li> <li>. The firebox lid will be extremely hot.</li> <li>. When grilling, grease from meat may drip into the charcoal and cause a grease fire. If this should happen, close the lid and dampers to suffocate the flame.</li> <li>. Do not use water to extinguish grease fires.</li> </ul>	<ul style="list-style-type: none"> <li>. Do not move the unit while it is being used.</li> <li>. Do not use in windy conditions.</li> <li>. Use caution when opening the lid, as hot steam or a flame flare-up could cause burns.</li> <li>. Before each use, make sure the unit is in good working condition.</li> <li>. Use caution after the fire has been extinguished, the surface will remain hot for some time.</li> <li>. Be sure all charcoals are cold before emptying, if necessary pour water on coals before moving grill.</li> <li>. Store the grill out of reach of children and in a dry location when not in use.</li> <li>. Check grease and or ash level in ash pan often and empty. Use extreme caution as the smoker, and metal ash pan will be hot.</li> <li>. When opening the lids, keep hands, face and body a safe distance from hot steam and flame flare-ups.</li> <li>. Do not allow charcoal and or wood to rest on the walls of the firebox and cooking chamber. Doing so will greatly reduce the life of the metal and finish of you smoker.</li> <li>. Close lids and all dampers to suffocate flame.</li> <li>. Never leave coals and ashes in grill unattended. Before grill can be left unattended, remaining coals and ashes must be removed from smoker.</li> <li>. Use caution when lifting or moving smoker to prevent strains and back injuries.</li> <li>. Properly dispose of all packaging material.</li> </ul>

USE CAUTION AND COMMON SENSE WHEN OPERATING YOUR SMOKER. READ ALL INSTRUCTIONS, WARNINGS AND SAFEGUARDS PRIOR TO ASSEMBLING AND OPERATING YOUR SMOKER.

**SAVE THESE INSTRUCTIONS**

# 8500 Parts List

**Note:** For assistance, including missing or damaged parts, call toll free - 866-475-5180 from 8:30 am - 4:30 pm Central Time, Monday - Friday

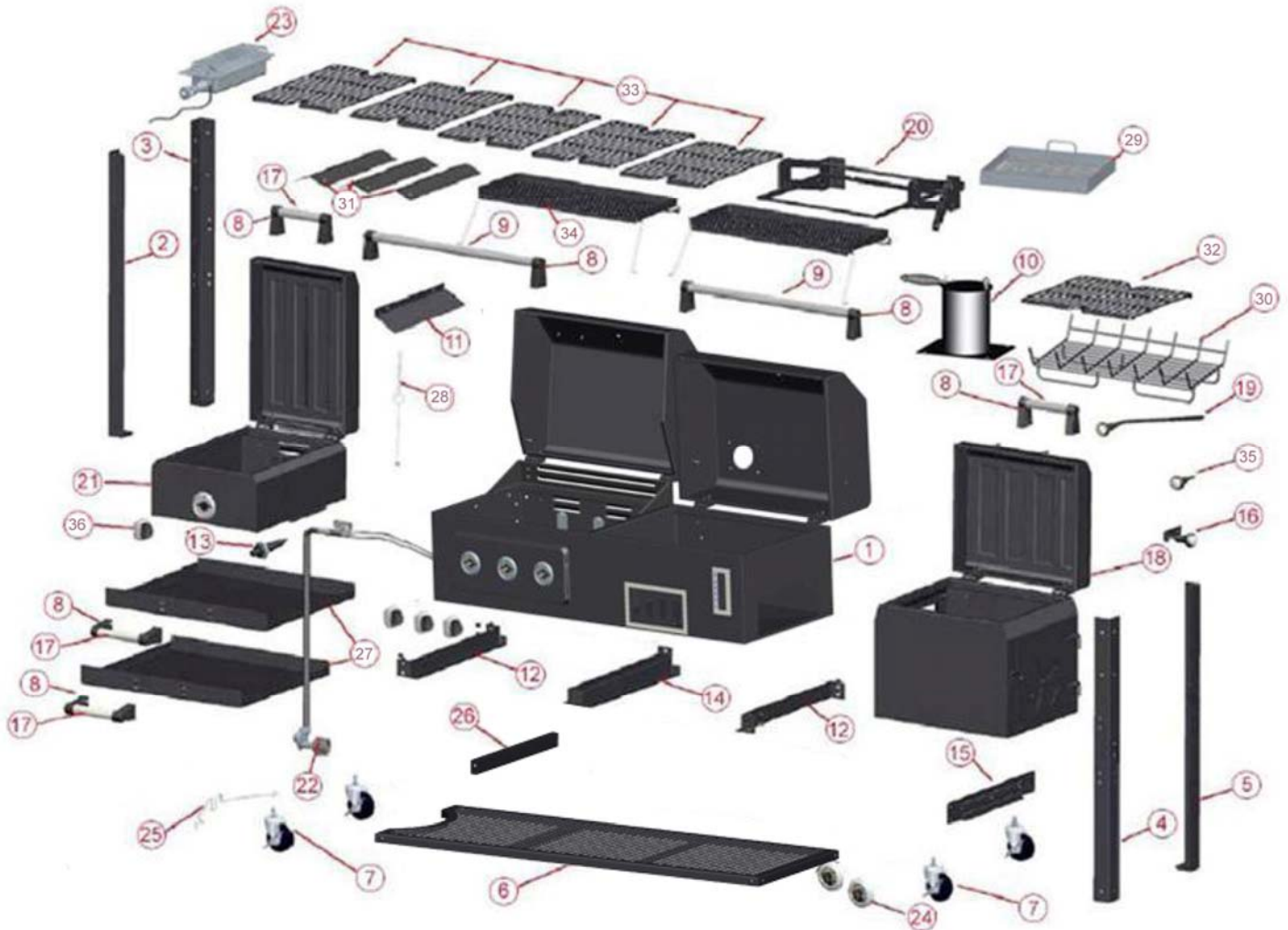

## Hardware Pack

Item Number	Quantity	Description
1	86	M6 x 15 Combo Truss Head Bolts, Black Nickel Plated
2	4	M6 x 30 Combo Truss Head Bolts, Black Nickel Plated
3	2	ST4.2 x 10 Screws. Black Nickel Plated
4	14	M6 KEPS Nuts. Black Nickel Coated
5	2	Hinge Pins, Bright Nickel Coated
6	2	"R" Clips. Black Nickel Coated
7	1	M6 Metal Lock Nut. Black Nickel Plated
8	1	Wheel Wrench

# 8500 Parts List

Item NO.	Quantity	Description	Part NO.
1	1	Gas and Charcoal Cabinet and Lid Assembly	8500-01
2	1	Left Front Leg — Green Label # 4	TR043
3	1	Left Rear Leg — Yellow Label # 3	TR044
4	1	Right Front Leg — Blue Label # 2	TR045
5	1	Right Rear Leg — White Label # 1	TR046
6	1	Bottom Shelf	TR047
7	4	Locking Caster Wheel	TR007
8	12	Handle Stand-off	TR008
9	2	Gas and Charcoal Lid Handle (Long)	TR009
10	1	Smoke Stack Assembly	7000CGS-03
11	1	Grease Pan Connector	TR011
12	2	Drip Tray Guides	47183T-13
13	1	Igniter for the Sear Burner	TR013
14	1	Centre Drip Tray Guide	TR014
15	1	Firebox Support Brace	TR015
16	1	Firebox Door Handle	TR016
17	4	Handle Tube for firebox, Sear Burner, and Drip Trays	TR017
18	1	Firebox Assembly and lid	TR018
19	1	Charcoal Tray Lift Handle	TR019
20	1	Charcoal Tray Lift System	TR020
21	1	Sear Burner Housing and Lid Assembly	TR021
22	1	Gas Hose, Regulator, (4) Control Valves, Control Knobs, and Manifold Assembly	TR022
23	1	Sear Burner	TR023
24	2	Heat Indicator with wing nut	TR041
25	1	Retaining Wire for LP Gas Cylinder	1800CGS-10
26	1	Retaining Support for LP Gas Cylinder	1800CGS-11
27	2	Drip Trays	TR028
28	1	Match Holder and Chain	TR029
29	1	Charcoal Tray	47183T-21
30	1	Firebox Wood Rack	TR031
31	3	Burner Heat Tent	TR032
32	1	Firebox Cooking Grid	TR033
33	5	Charcoal and Sear Burner Cooking Grids	47183T-11
34	2	Warming Rack Assembly	TR035
35	1	Charcoal Damper Handle	TR036
36	4	Burner Control Knob	TR037
37	1	Hardware Blister Pack	8500-02B
38	1	Instruction Manual	8500-03B
39	3	Burner, (factory installed in Cabinet)	TR040

# Assembly

**Note:** Carefully cut the straps holding the carton together. Cut the carton sleeve so that it can lay flat on the ground to provide a clean surface for assembling your Grill. Remove the packing materials and all the parts from inside the Cabinet. After unpacking all the parts, check to make sure you HAVE all the parts. If anything is damaged or missing, contact our toll free number: 866-475-5180. Discard all packing material in a safe and recyclable manner. Save this Assembly Manual for future reference.

Tools Required: Phillips Head Screwdriver, Adjustable Wrench or Pliers

## Step 1

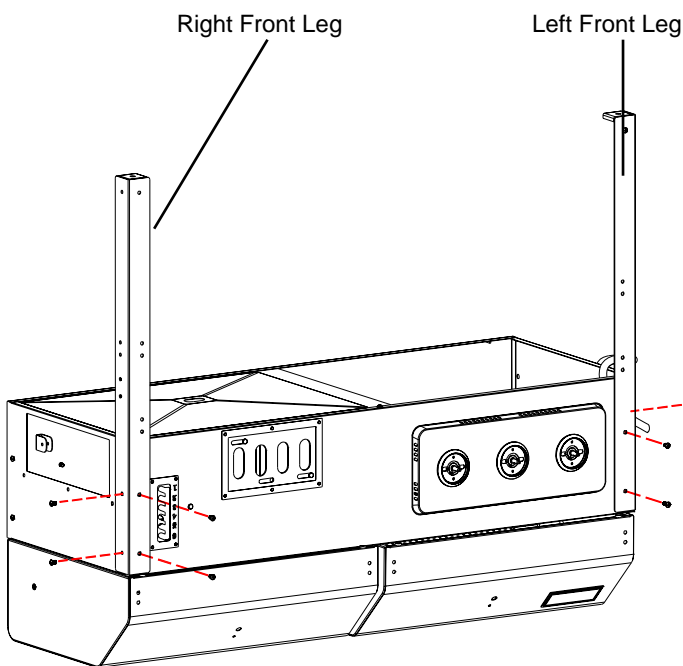

Fig. 1

## Step 1: Front Leg Assembly

*Locate:* Cabinet and Lid Assembly, Left Front Leg - green label # 4, Right Front Leg - blue label #2 and (7) M6x15 bolts.

*Note:* Each leg will have an identification label. Do not fully tighten any leg bolts until instructed to do so later in the assembly.

*Procedure:*

Position cabinet upside down and attach left front leg using (3) M6x15 bolts and right front leg using (4) M6x15 bolts as shown in Figure 1.

## Step 2

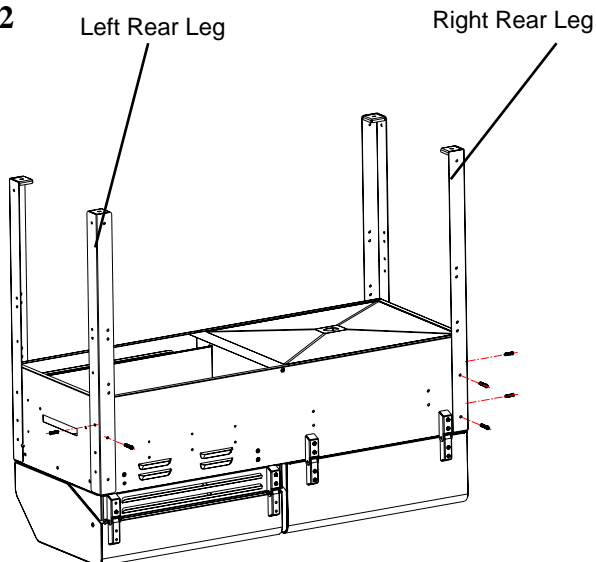

Fig. 2

## Step 2: Rear Leg Assembly

*Locate:* Left Rear Leg - yellow label #3, Right Rear Leg - white label # 1 and (6) M6x15 bolts.

*Procedure:*

Attach left rear leg using (2) M6x15 bolts and right rear leg using (4) M6x15 bolts.

# Assembly

## Step 3

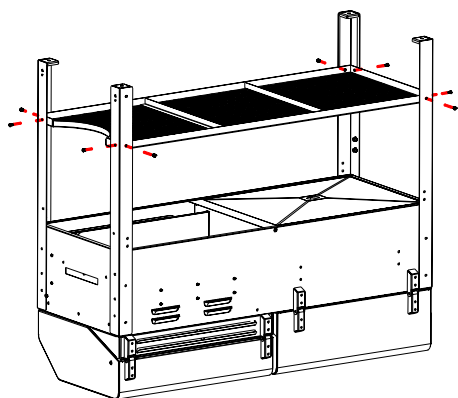

Fig. 3

## Step 3: Attach Bottom Shelf Assembly

*Locate:* Bottom Shelf and (8) M6x15 bolts.

*Procedure:*

Refer to Fig. 3 and attach the Bottom Shelf to the Legs as shown using (2) M6x15 bolt in each leg.

**NOTE:** Make sure the side of the bottom shelf with the cylinder opening is facing the gas grill side.

## Step 4

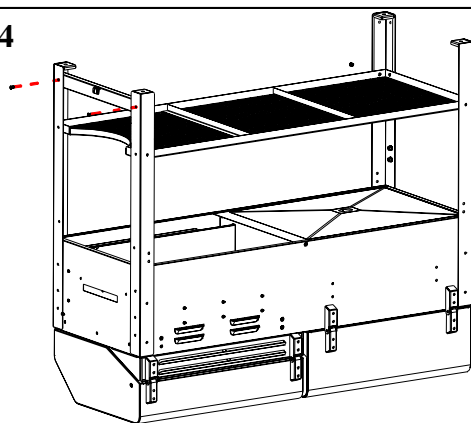

Fig. 4

**FULLY TIGHTEN ALL BOLTS USED IN STEPS 1, 2 AND 3.**

## Step 4: Retaining Support Assembly

*Locate:* Retaining Support and (2) M6x15 bolts.

*Procedure:*

Attach retaining support using (2) M6x15 bolts as figure 4.

## Step 5

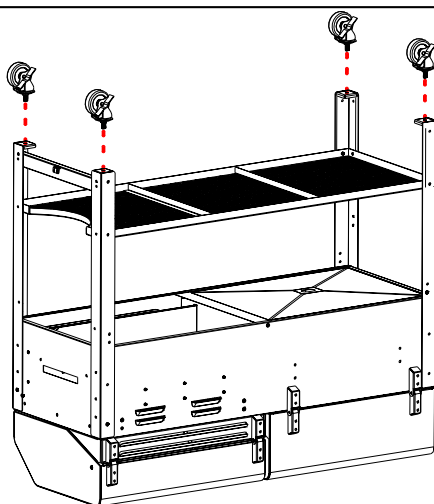

Fig.5

## Step 5: Caster Wheel Assembly

*Locate:* 4 Caster Wheels

*Procedure:*

Insert the threaded end of the castor wheel into the bottom of each leg as shown in Figure 4 and fully tighten with the wrench provided in the hardware pack.

Lock all (4) Caster wheels so they cannot turn.

## Step 6

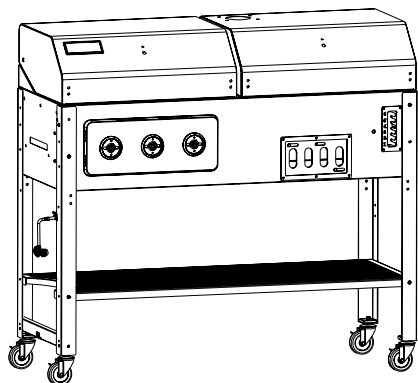

Fig. 5

## Step 6: Check your Progress

Stand the grill up onto its castor wheels and it should look like the image in Figure 5.

# Assembly

## Step 7

Fig. 7A

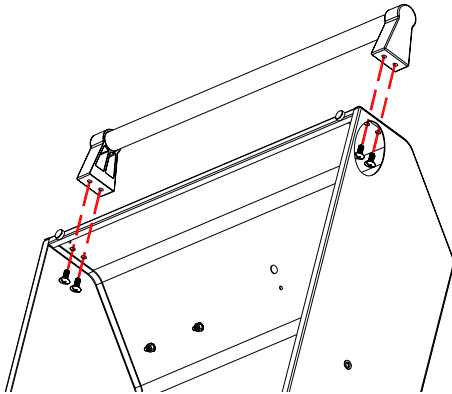
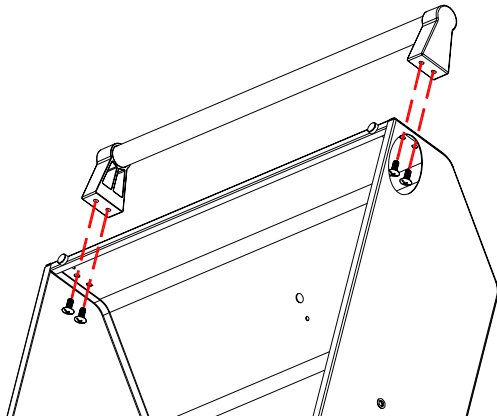

Fig. 7B



## Step 7: Assemble Handle to the Gas Lid and Charcoal Lid

*Locate:* Gas and Charcoal Lid, (4) Handle Stand-offs, (2) Long Handle Tube and (8) M6x15 bolts.

*Procedure:* Refer to Fig. 7A. Place (2) M6x15 bolts through the Lid holes on one side of the Gas Lid. Fit a Handle Stand-off over the bolts and attach the Stand-off to the Gas Lid. Fit the long Handle Tube into both Stand-offs and then repeat the procedure of inserting the screws through the Lid and into the other Stand-off. Tighten all (4) bolts securely.

Repeat the procedure as above when assembling the Handle to the Charcoal Lid. Showing as Fig.7B.

## Step 8

Fig. 8A

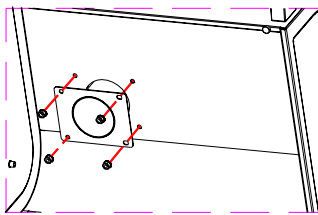
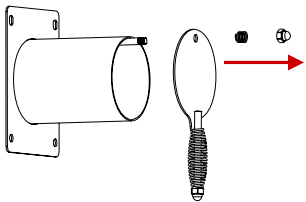

Fig. 8B

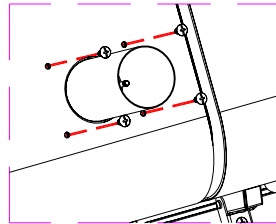

Fig. 8C

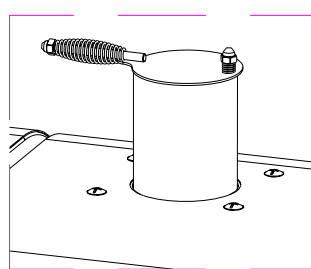
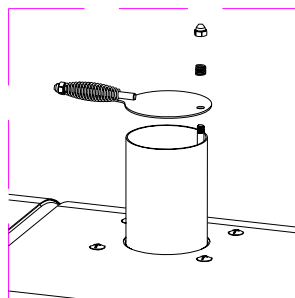

Fig. 8D

## Step 8: Attach the Smoke Stack

*Locate:* Smoke Stack Assembly, (4) M6x15 bolts and (4) M6 KEPS nuts.

*Procedure:* Remove Smoke Stack Cover as shown in Figure 8A. Then insert Smoke Stack through the Grill Lid from the INSIDE as shown in Figure 8B.

*Note:* The Smoke Stack Cover attaching screw MUST be located towards the right hand side of the Lid, as shown in Figure 8D.

Attach the Lid to the Smoke Stack using M6x15 bolts inserted through the Lid from the OUTSIDE, with the M6 KEPS nuts positioned and tightened on the INSIDE of the Lid as shown in Figure 8C. Then replace the Smoke Stack Cover as shown and the position of the Handle should be as shown in Figure 8D.

# Assembly

## Step 9

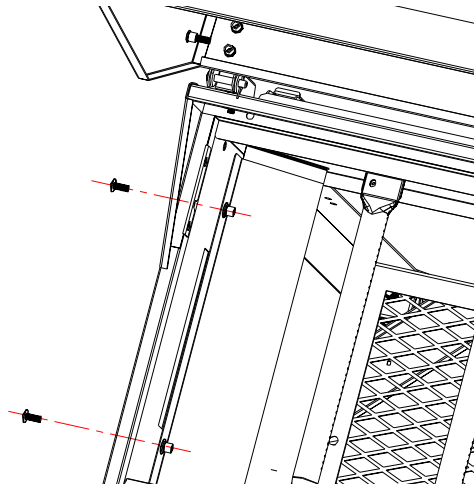

Fig. 9

## Step 9: Install Grease Pan Connector

*Locate:* Grease Pan Connector and (2) M6x15 bolts.

*Procedure:*

Place the grease pan connector inside the left end of the cabinet just below the horizontal slot and insert (2) M6x15 bolts from outside the cabinet as shown in Figure 9.

## Step 10

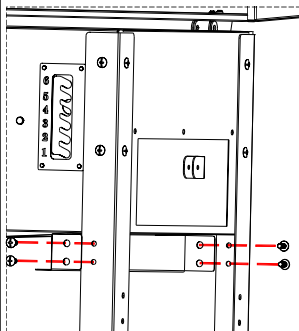

Fig. 10A

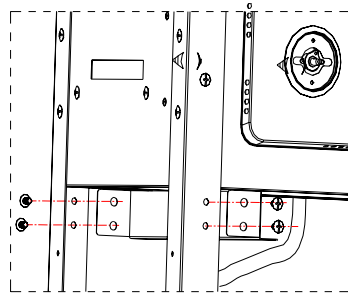

Fig. 10B

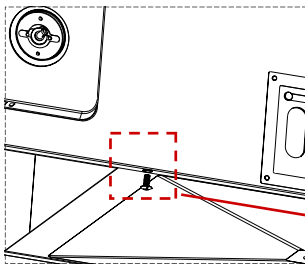

Fig. 10C

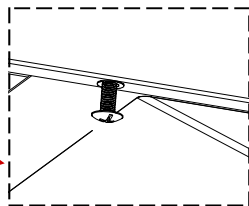

Fig. 10D

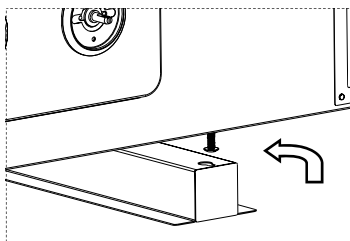
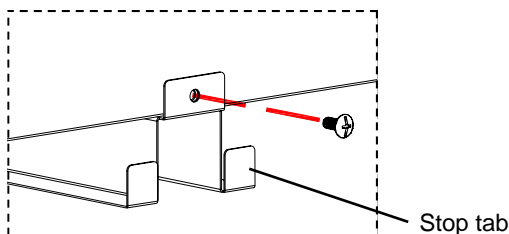

Fig. 10E



## Step 10: Install the Drip Tray Guides (Right, Left and Center)

*Locate:* Side Drip Tray Guides, Center Drip Tray Guide and (10) M6x15 bolts.

*Procedure:*

Place side drip tray guide inside the right legs as shown in Figure 10A and attach using (4) M6x15 bolts.

Place side drip tray guide inside the left legs as shown in Figure 10B and attach using (4) M6x15 bolts. Be sure the LP gas line is positioned outside the left drip tray guide as shown in Figure 10B.

From in front of the grill, find the threaded hole on the underside of the cabinet and partially insert an M6x15 bolt as shown in Figure 10C. Position the center drip tray guide so that the keyhole fits over the partially installed bolt (See Figure 10D). Then push the guide toward the back of the grill cabinet so that the tab fits over the threaded hole in the lower back side of the cabinet and insert an M6x15 bolt as shown in Figure 10E. Fully tighten both M6x15 bolts.

# Assembly

## Step 11

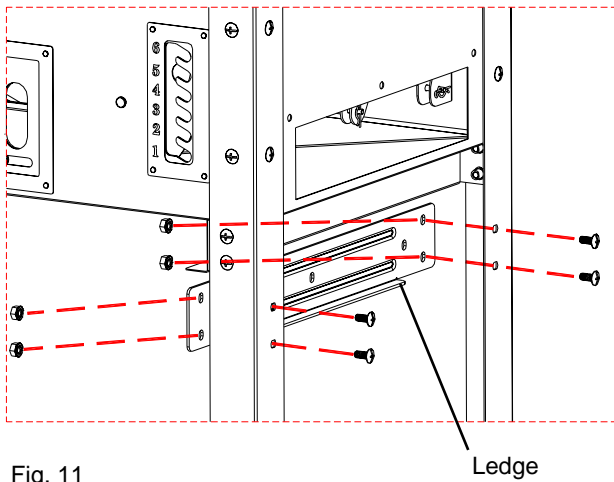

Fig. 11

Ledge

## Step 11: Install Firebox Support Brace

*Locate:* Firebox Support Brace, (4) M6x15 bolts and (4) M6 KEPS nuts.

*Procedure:*

Place the firebox support brace between the legs on the right end of the grill so that the ledge is at the bottom and facing to right as shown in Figure 11. Insert M6x15 bolts through the legs and then through the brace as shown. Attach M6 KEPS nuts on the inside and fully tighten.

## Step 12

Fig. 12A

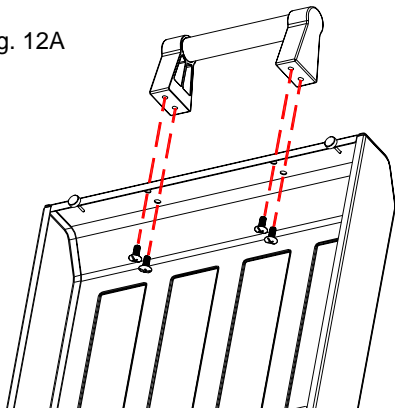
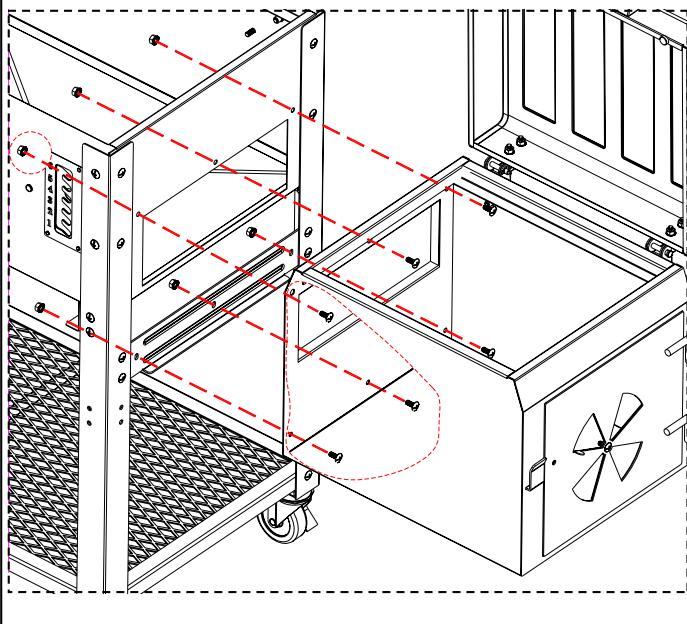

Fig. 12B



## Step 12: Attach the Handle to the Firebox Lid and the Firebox to the Grill Assembly

*Locate:* Firebox and Lid Assembly, (2) Handle Stand-offs, (1) Short Handle Tube, (10) M6x15 bolts, , and (6) KEPS nuts

*Procedure:* Refer to Fig. 12A. Open the Firebox Lid and place (2) M6x15 bolts through the Lid holes on one side of the Lid. Fit a Handle Stand-off over the bolts and attach the Stand-off to the Lid. Fit the Short Handle Tube into both Stand-offs and then repeat the procedure of inserting the screws through the Lid and into the other Stand-off. Tighten all (4) bolts securely.

Refer to Fig. 12B and Align the Firebox Assembly with the rectangular opening in the right side of the Grill Cabinet, so that it is resting on the ledge of the Firebox Support Bracket. Insert (3) M6x15 bolts through the Firebox and the Cabinet Wall. Attach (3) M6 KEPS nuts to each of the bolts. Insert (3) M6 x15 bolts through the Firebox and the Firebox Support Bracket and attach (3) KEPS nuts to the bolts. Make certain that all bolts are securely tightened.

# Assembly

## Step 13

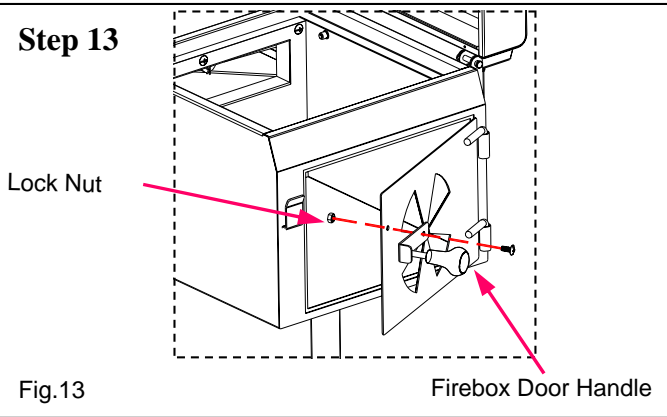

## Step 13: Attach the Firebox Door Handle

*Locate:* Firebox and Lid Assembly, Firebox Door Handle, (1) M6x15 bolt and (1) Metal lock nut

*Procedure:* Refer to Fig. 13 and Place the Firebox Door Handle on the outside of the Firebox Door and insert an M6x15 bolt through the Door Handle and the Door as shown. Attach an M6 metal lock nut. Tighten with wrench or pliers until the Handle can still move freely.

## Step 14

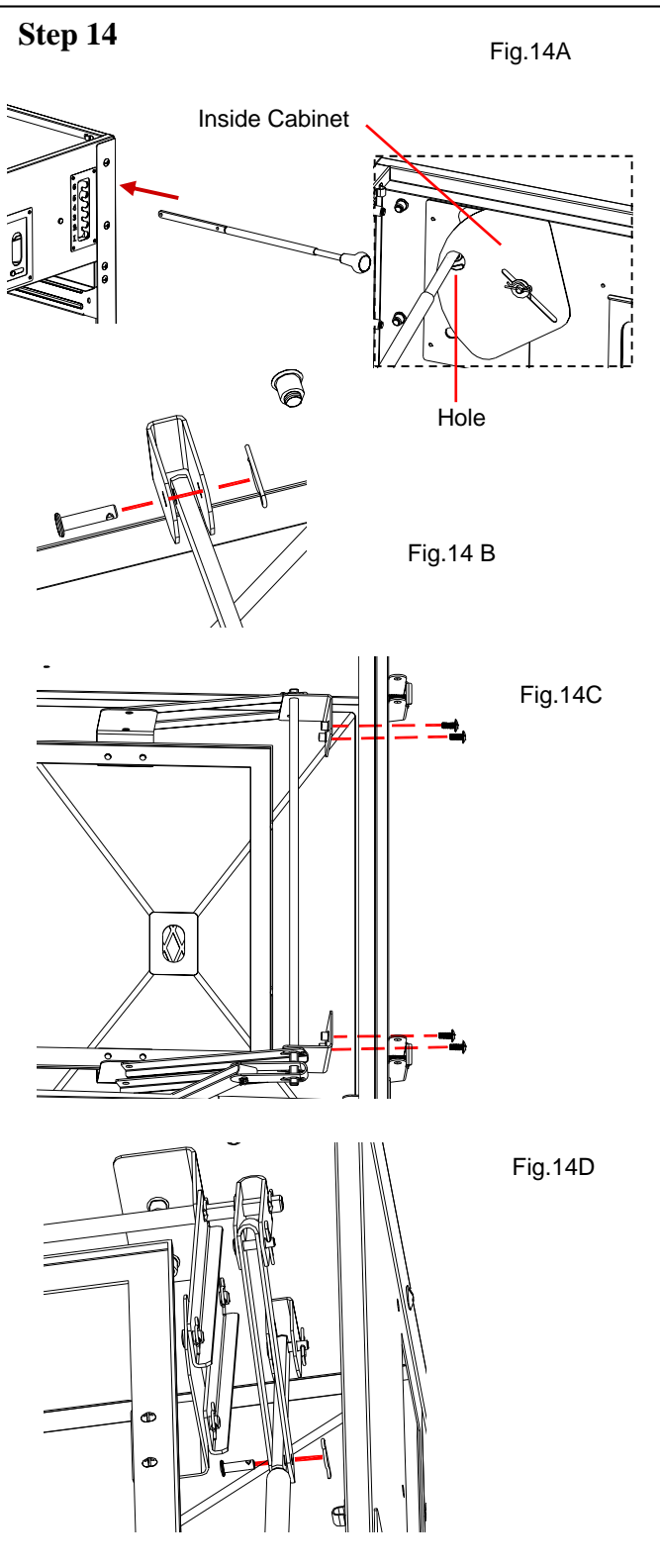

## Step 14: Installing the Charcoal Tray Lifting System

*Locate:* Charcoal Tray Lift Handle, Charcoal Tray Lifting System, (4) M6x15 bolts, (2) Hinge Pins and (2) "R" Clips

*Procedure:* Slide the charcoal tray lift handle through the adjusting slot and through the hole of the inside plate as shown in Figure 14A. Align the hole in the end of the lift handle with the holes in the "U" shaped bracket located at the back of the cabinet. Join the lift handle and the "U" shaped bracket by inserting a hinge pin as shown in Figure 14B. Then insert an "R" clip through the hole in the hinge pin.

Place the charcoal tray lifting system into the cabinet and attach it to the back wall by inserting (4) M6x15 bolts through the back side of the cabinet wall as shown in Figure 14C.

Attach the charcoal tray lift handle to the charcoal tray lifting system by inserting a hinge pin through the "U" shaped lifting arm and the hole in the center of the lifting handle as shown in Figure 14D. Then insert an "R" clip through the hole in the hinge pin.

You should now be able to adjust the charcoal tray lifting system to your desired height by moving the lifting handle to the left and raising or lowering it.

# Assembly

## Step 15

Fig. 15A

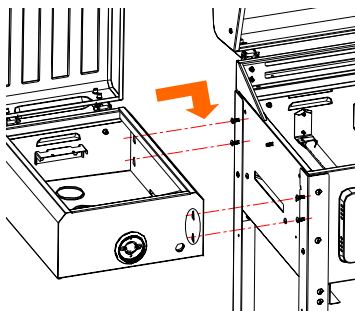
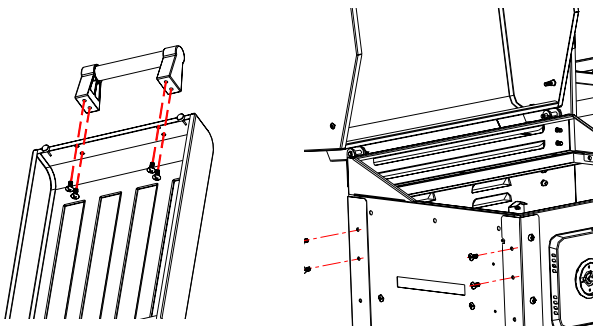

Fig. 15B

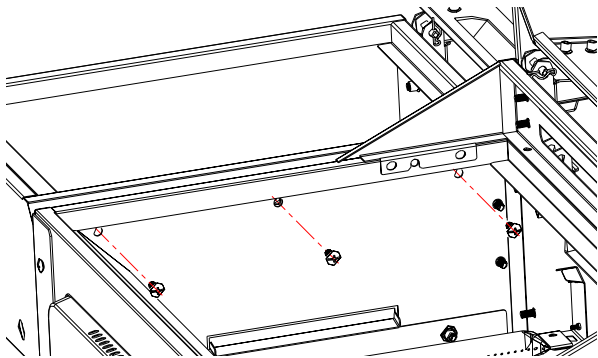

Fig. 15C

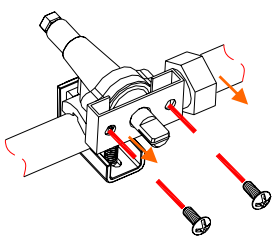

Fig. 15D

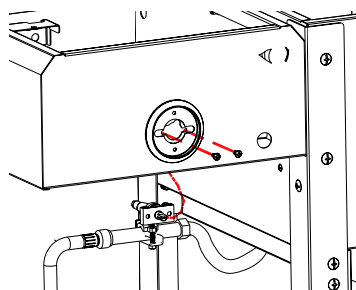

Fig. 15E

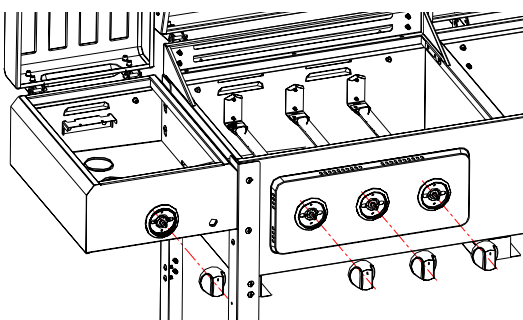

Fig. 15F

## Step 15: Schar Burner Assembly

*Locate:* Schar Burner Housing and Lid, Schar Burner, Schar Burner Control Knob, (11) M6x15 bolts and (2) ST4.2 x10 Screws, (2) Handle Stand-offs, (1) Short Handle Tube.

### *Procedure:*

Refer to Fig. 15A - Open the Schar Burner Lid and place (2) M6x15 bolts through the Lid holes on one side of the Lid. Fit a Handle Stand-off over the bolts and attach the Stand-off to the Lid. Fit the Short Handle Tube into both Stand-offs and then repeat the procedure of inserting the screws through the Lid and into the other Stand-off. Tighten all (4) bolts securely.

Screw (4) M6x15 bolts into the (4) threaded holes in the left side of the grill cabinet as shown in Figure 15A, and leave about 1/4" of each screw sticking out, as in Figure 15B.

Hang the schar burner housing onto the grill cabinet, so all (4) bolts fit into the holes of the schar burner housing. Insert and tighten (3) M6x15 bolt from the inside of the grill cabinet through and into the schar burner housing as show in Figure 15C, and tighten the bolts. Note: (2) bolts are tightened from the underside of the schar burner housing.

The next step is to attach the schar burner valve to the schar burner housing. Remove the (2) M4x8 screws from the schar burner valve as shown in Figure 15D. Then position the valve in place between the front panel of the schar burner housing and the inner wall as shown in Figure 15E. Align the threaded holes in the valve with the holes in the schar burner housing and attach using the (2) M4x8 bolts that were removed earlier.

Place the schar burner control knob over the valve stem, making sure to align flat portion of both components, and push the control knob over the stem until it is firmly seated. See Figure 15F. Use this same procedure to install the (3) gas control knobs on the gas grill control panel.

# Assembly

## Step 15

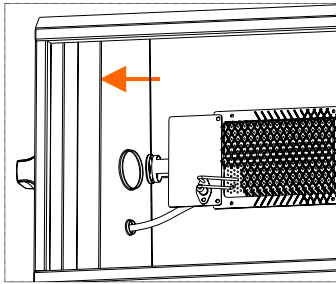

Fig. 15G

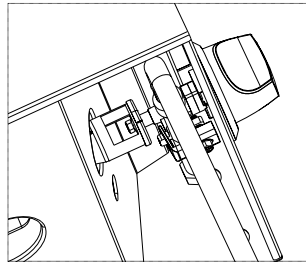

Fig. 15H

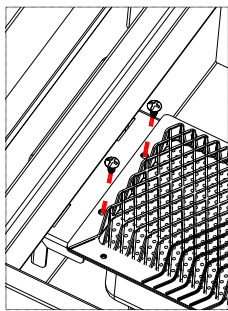

Fig. 15I

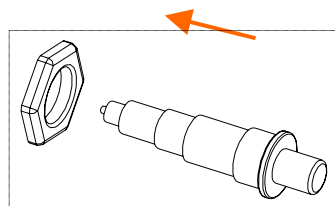

Fig. 15J

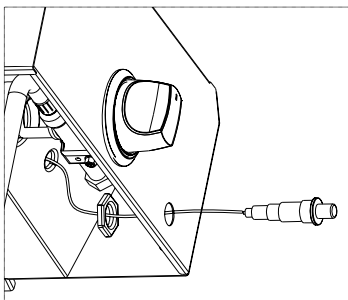
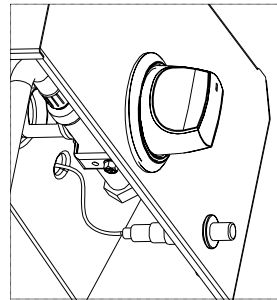

Fig. 15K



## Step 15: Sear Burner Assembly (Continued)

Locate the sear burner, tilt the sear burner up and slide the tube through the inner wall and onto the valve as shown in Figure 15G. From the underside of the sear burner housing, check to make sure the valve is inside the tube as shown in Figure 15H.

Now attach the Sear Burner to the bracket located on the back wall of the Sear Burner Housing using (2) ST4.0 x10 Screws as shown in Figure 15I.

Remove the large nut from the igniter as shown in Figure 15J push the other end of the wire through the hole into the underside of the housing. And slide the wire through the nut and through the hole on the outside of the housing.

Attach the wire to the stem of the igniter. Push the igniter and wire through the hole and attach it to the housing by screwing the nut back onto the igniter as shown in Figure 15K.

## Step 16

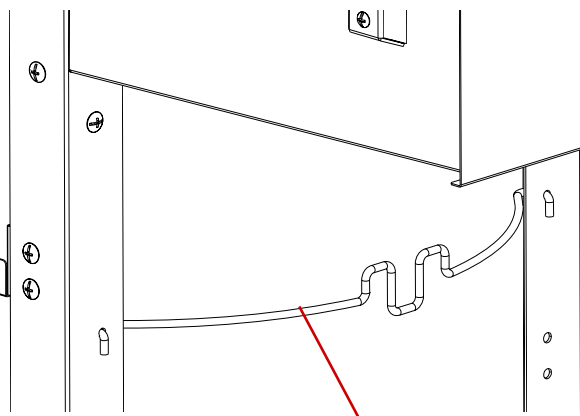

Retaining Wire

Fig.16

## Step 16: Attach Retaining Wire for LP Gas Cylinder

*Locate:* Retaining Wire

*Procedure:*

Attach retaining wire to legs at left end of grill as shown in Figure 16. Position the retaining wire inside the legs and under the grill body with the curved side up. Then insert the ends of the wire through the holes in the legs and rotate the wire toward you.

# Assembly

## Step 17

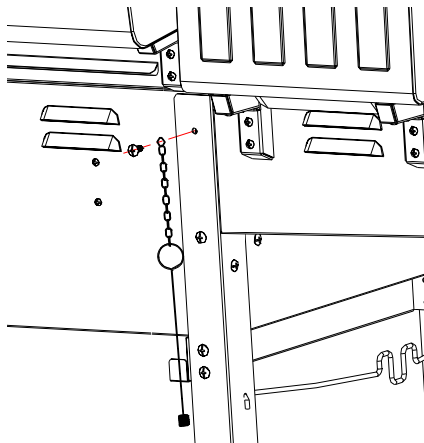

Fig.17

## Step 17: Attach Match Holder and Chain

*Locate:* Match Holder & Chain and (1) M6x15 bolt.

*Procedure:* Attach match holder and chain to the top rear hole in the left rear leg by inserting an M6x15 bolt through the loop at the end of the chain and securely tightening. See Figure 17.

## Step 18

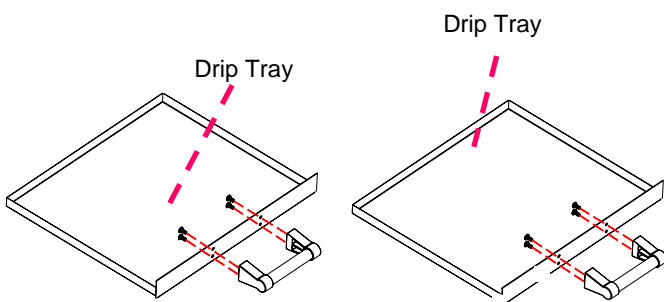

Fig.18A

## Step 18: Attach handles to Drip Trays

*Locate:* (2) Drip Trays, (4) Handle Stand-offs, (8) M6x15 bolts, (2) short handle tubes,

*Procedure:* Refer to Fig. 18A - Place (2) M6x15 bolts through the holes on one side of the Trays. Fit a Handle Stand-off over the bolts and attach the Stand-off to the Drawer. Fit the Short Handle Tube into both Stand-offs and then repeat the procedure of inserting the screws through the Trays and into the other Stand-off. Tighten all (4) bolts securely for (2) Drip Trays one by one.

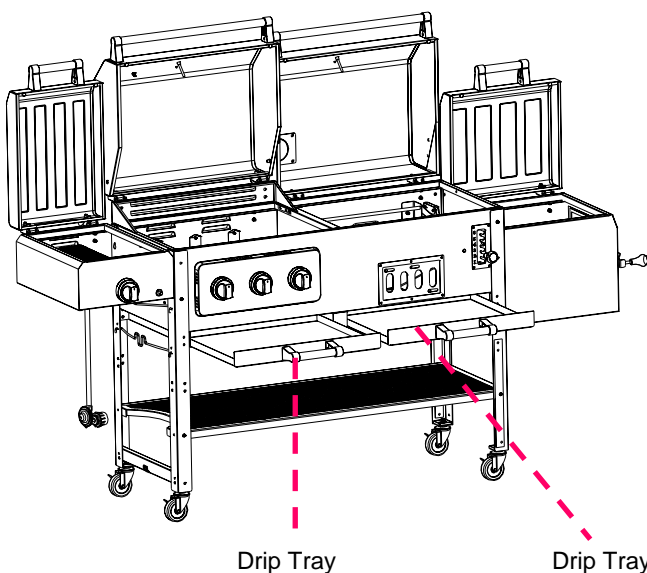
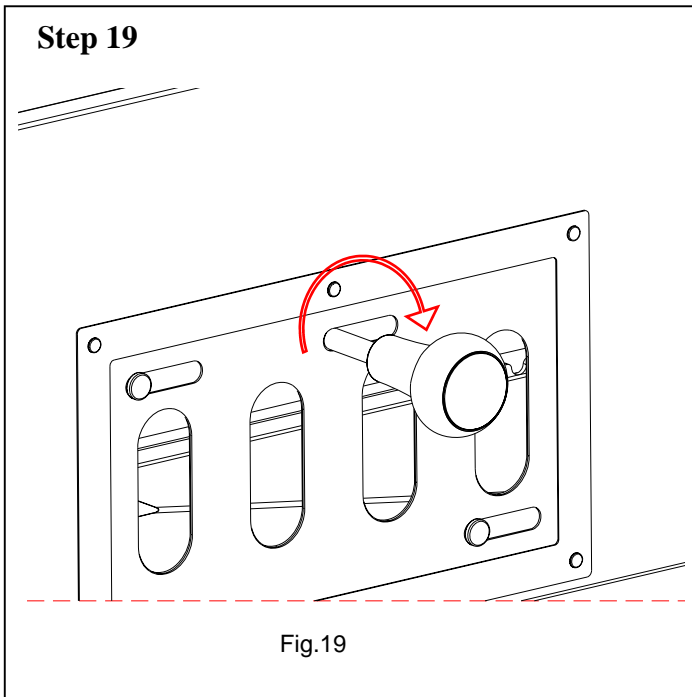

Fig.18B

**Note: Grease Drip Trays and Grease Cup Should be emptied and cleaned after each use to prevent flare – ups and /or grease fires.**

# Assembly

## Step 19



## Step 19: Attach Charcoal Damper Handle

*Locate:* Charcoal Damper Handle

*Procedure:*

Screw the handle into the hole located above the vertical slots on the charcoal side of the grill. The handle should slide back and forth to open and close the damper.

## Step 20

Fig. 20A

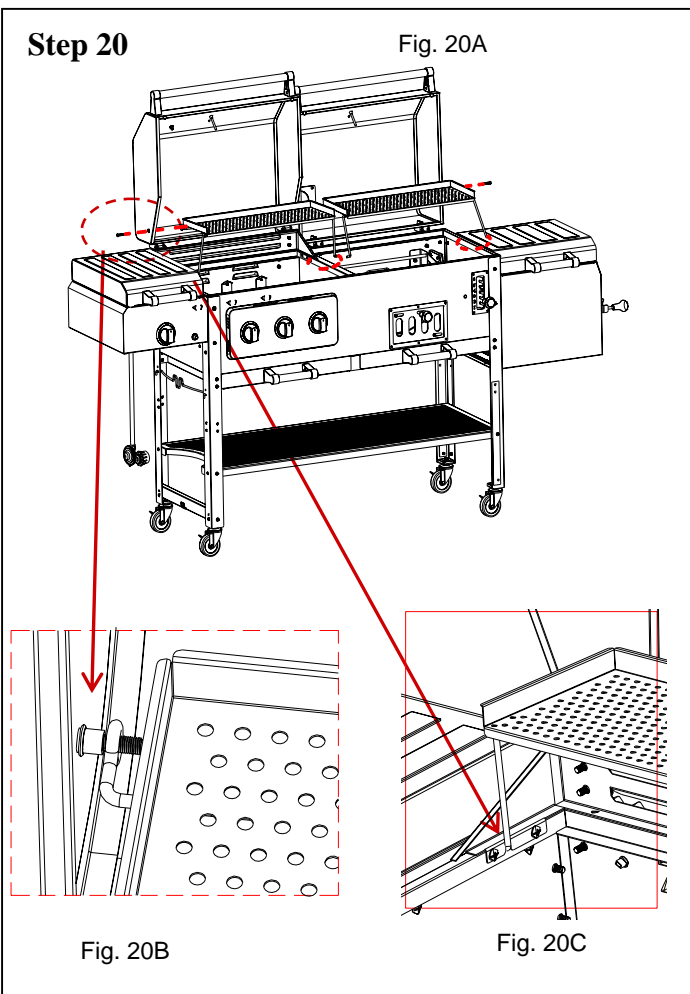

## Step 20: Install Warming Racks

*Locate:* (2) Warming Racks and (4) M6x30 bolts

*Procedure:* To attach the warming racks, insert (1) of the M6x30 bolts through the lid from the outside as shown in Figure 20A and position the warming rack so that the bolt is going through the wire loop as shown in Figure 20B. Then align the wire loop on the opposite end of the warming rack with the opposite lid hole and insert the other M6x30 bolt.

Insert the wire legs into the holes on the sides of the cabinet as shown in Figure 20C. Repeat this procedure for the second Warming Rack.

# Assembly

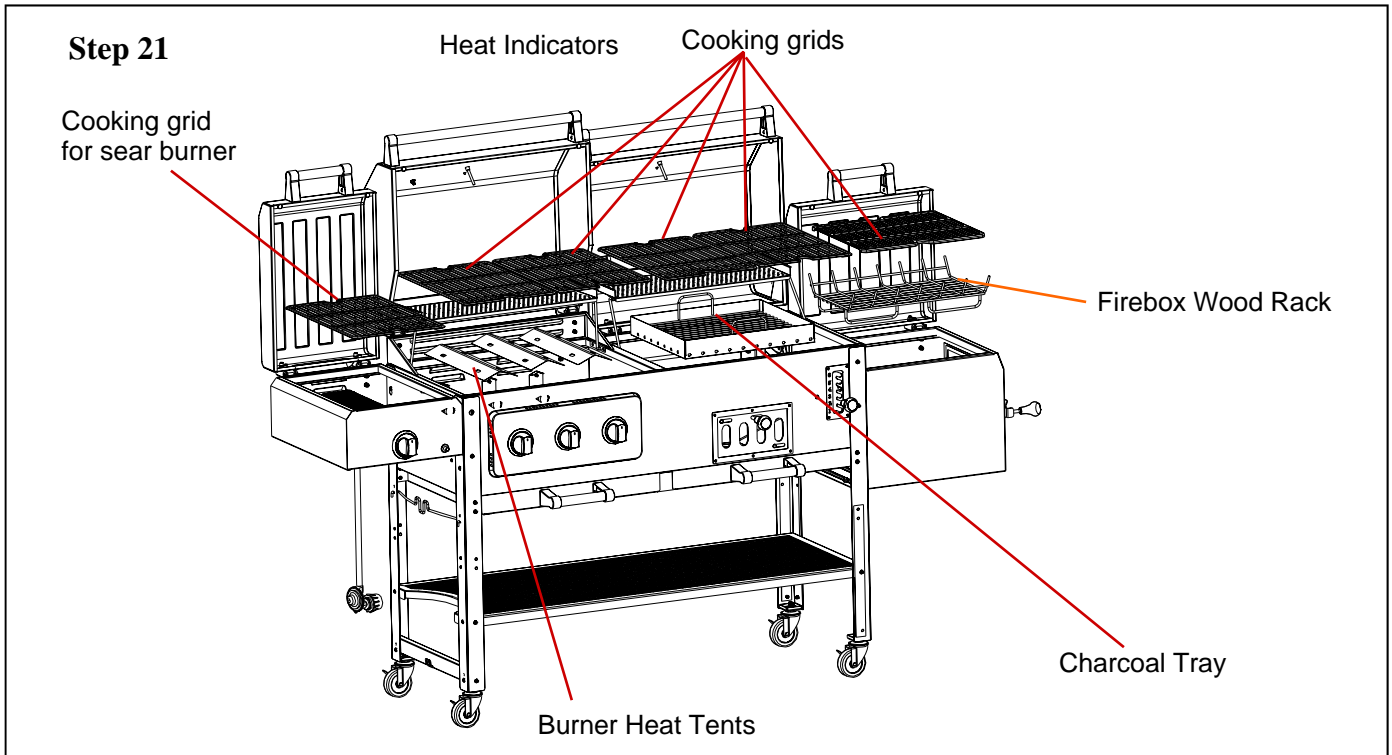

**Step 21: Install (2) Heat Indicators, (3) Heat Tents, (1) Charcoal Tray, (1) Firebox Wood Rack and (6) Cooking Grids.**

- Locate (2) Heat Indicators and remove wing nuts from each. Insert one heat indicator through gas grill lid and one through charcoal grill lid. Securely fasten each heat indicator with the wing nuts.
- Place one heat tent onto the tabs located above each burner in the gas grill cabinet.
- Place the charcoal tray into the charcoal cabinet so that it rests on the charcoal tray lifting system.
- Place firebox wood rack inside firebox.
- Place the cooking grids in the sear burner, firebox, charcoal grill and gas grill.



Assembly of your grill & smoker is now complete.

To order a cover for your grill, please visit: [www.thesmokercompany.com](http://www.thesmokercompany.com)

**FOR YOUR SAFETY, FOLLOW ALL SAFEGUARDS AND INSTRUCTIONS.**

## OPERATING INSTRUCTIONS

### Connecting the LP gas cylinder to the grill

- The LP Gas Cylinder must be a 20 pound cylinder and have a Type 1 Cylinder Valve Outlet Connector.
- Handle the Cylinder with care - do not drop it.
- When you are not using the grill, the LP Gas Cylinder should be disconnected.
- Connect the regulator and hand tighten firmly.
- Do a leak test each time you connect a LP Gas Cylinder and before lighting the grill.
- Never use a match or lit flame to test for leaks.
- To test, prepare a weak solution of detergent and water. Spray or swab the solution onto the connection of the regulator to the LP Gas Cylinder valve, and on all the joints in the hose connections up to the burner valves (which MUST be closed in the "OFF" position).
- Open the LP Gas Cylinder valve, and watch for any bubbles to appear at all the connection points. No bubbles indicate - All Clear!
- If there are any bubbles, there is a leak which must be fixed.
- Never obstruct the flow of combustion and ventilation air.

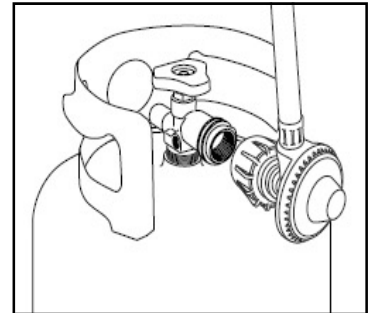

### Lighting the grill

- Always open the Lid before lighting the grill.
- All burner knobs should be in the "OFF" position.
- Open the LP Gas Cylinder valve, 1-1 1/2 turns.
- Note: EACH of the 3 main burners on your grill has its own automatic igniter.
- Push the knob in fully, and slowly turn it counter-clockwise (to the left) to the "HIGH" position. You will hear a loud "Click" as the igniter sparks and lights the burner.
- You can then adjust the knob to your desired setting.
- If the burner did not light, turn the knob back to the "OFF" position, wait 5 minutes for any gas to clear away, and then repeat the lighting procedure.
- For Sear Burner, turn the knob counter-clockwise (to the left) and then PUSH the Black Igniter Button several times to light the burner. If the burner does not light, then turn the knob to the "OFF" position, wait 5 minutes and then try again.
- After using the grill, - turn all burner knobs to the "HIGH" position and then push fully in and turn to the "OFF" position.
- At once turn the valve on the LP Gas Cylinder OFF.
- IF the auto-igniter does NOT light the burner, you can light it with a match or a piece of burning paper - hold the match or paper with the Match Holder ( attached at the side of the grill) , put it through the openings in the Cooking Grid and next to the Flame Tent covering the burner. Then follow the lighting procedure above.
- Observe the proper burner flame - it should be a blue/yellow color about 1/2" long.

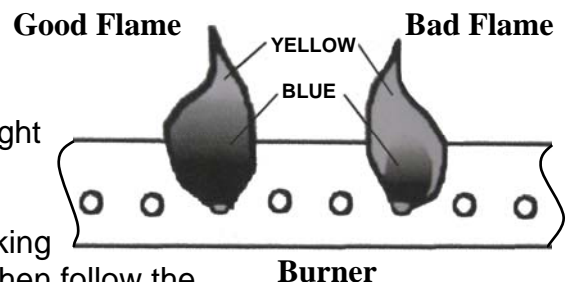
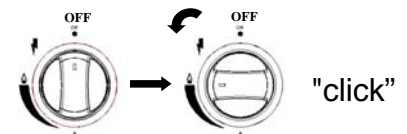

### Sear Burner Operation

- ALWAYS be sure to OPEN the Lid before lighting the Sear Burner and leave open during use. Leave Sear Burner open until it is completely cool.
- Preheat the Burner for 5 minutes
- Sear one side of the food, turn the food over and sear the other side. Then continue cooking each side of the food on the standard burners until done to your satisfaction.

## OPERATING INSTRUCTIONS

### CARE AND CLEANING

#### ! WARNING !

- Do not do any cleaning or maintenance on any grill parts until all parts are cool! Be sure that the valve on the LP Gas Cylinder is closed and in the OFF position
- After every cooking session, you may run the gas grill on HIGH, or set the Charcoal Coals into the HIGH position to burn off any food residue, keeping the residue from building up.

#### CLEANING

- Use only mild dishwashing detergents, hot water, a nylon scrub pad and a BBQ wire brush cleaning tool
- Always rinse all surfaces thoroughly after cleaning
- Handle Porcelain coated surfaces gently and carefully- they are made from high temperature glass and can chip easily
- **Note: Grease Drip Trays and Grease Cup should be emptied and cleaned after each use to prevent flare – ups and /or grease fires.**

#### Burners

1. Turn the gas OFF at the LP Gas Cylinder and the burner control knobs
2. Lift off the cooking grids and the heat tents covering the burners
3. Remove the screw attaching the burners at the back of the grill
4. Gently and carefully, tilt the back of the Burner up and slide it backwards off the valve orifice, then lift out of the grill
5. Wipe clean the orifice face

### TROUBLE SHOOTING THE GAS GRILL

#### Burner does not light :

1. Check if LP Gas Cylinder is empty?
2. Check Igniter wire – is there a spark?
3. Check for spider webs or insect nests inside, clogging the Burner

#### Flame color is Yellow, should be Blue:

1. Check for spider webs or insect nests inside, clogging the Burner
2. Close Lid and run on HIGH to burn off residue on Burner

#### Flame flares up:

1. Cooking temperature is set too high
2. Food being cooked is too fatty
3. Grease has accumulated in the grill. Clean and burn off

## OPERATING INSTRUCTIONS

### ! IMPORTANT ! CURING PROCESS

#### LP GAS GRILL

Step 1: Lightly coat ALL INTERIOR surfaces (including interior of lids, cooking grids and area below the cooking surface) with vegetable oil or vegetable oil spray.

Step 2: Ignite the LP gas grill side and burn at medium temperature for one hour.

Step 3: Let the grill cool completely and it is ready for use.

#### CHARCOAL GRILL & FIREBOX

Step 1: Lightly coat ALL INTERIOR surfaces (including interior of lids, cooking grids and area below the cooking surface) with vegetable oil or vegetable oil spray.

Step 2: Start a charcoal fire using 1-2 lbs of briquette or lump charcoal. Keeping the lids open until the flames have burned down.

Step 3: After flames have burned down close lids and all dampers and maintain fire at 300 to 400 degrees Fahrenheit for one hour.

Step 4: Let the fire burn out and grill cool completely before use.

### CHARCOAL GRILL OPERATING INSTRUCTION

The charcoal offset Fire Box Grill & Smoker can be used to cook food either by:

**CHARCOAL AND DIRECT HEAT –OR- SMOKE AND INDIRECT HEAT**

Please read all steps before cooking.

### TO COOK USING CHARCOAL AND DIRECT HEAT

(The fire is in the Charcoal Cooking Chamber and the food is in the Charcoal Cooking Chamber.) Follow these steps for cooking with charcoal and direct heat in the Charcoal Cooking Chamber.

1. For best results use a metal charcoal starter and fill the starter with about 2 lbs of charcoal and light the charcoal.
2. After 30 minutes, dump the charcoal into the bottom of the Smoker Chamber on the charcoal grates, which should be at the lowest adjustment.
3. Adjust the Fire Box and Smoker Chamber dampers to 1/4 to 1/3 open.
4. Immediately and carefully place another 2 lbs of charcoal on top of the burning coals in the Smoker Chamber.
5. Once the temperature reaches your desired level, food can be placed on the cooking grates.



*The adjustable charcoal grate in the Smoker Chamber allows the charcoal grate to be moved to within a few inches of the cooking grate allowing you to sear your meat and lock in the juices. Searing takes only a few minutes on each side. Don't allow the meat or food to burn. After searing, crank the charcoal grate back to the bottom and cook the food to your personal preference.*



*For smaller cookouts, the Fire Box can be used instead of the larger Smoker Chamber for cooking with charcoal and direct heat. Follow the same steps above for cooking in the main Smoker Chamber.*

FOR YOUR SAFETY, FOLLOW ALL SAFEGUARDS AND INSTRUCTIONS.

## OPERATING INSTRUCTIONS

### TO COOK USING SMOKE AND INDIRECT HEAT



*(The fire is in the Fire Box and the food is cooked or smoked in the Smoker/Cooking Chamber. The smoke and the indirect heat pass through the opening between the Fire Box and Smoker/Cooking Chamber. Follow the steps below for smoking and/or cooking . Note that the indirect cooking or smoking process will take longer than traditional barbecuing. At 225 to 250 degrees, it will take approximately 30 minutes per pound of meat.)*

1. Fully open Smoke Stack and damper on Firebox Door.
2. Place 2 pounds of charcoal on Firebox charcoal grate. Light charcoal and allow it to burn until coals are glowing. Add your desired flavoring, Wood (hickory, mesquite, pecan, apple, alder, etc.) to the charcoal.
3. For indirect cooking, we recommend 225-250°F. For smoking, the desired temperature may be lower.  
The heat and smoke can be regulated by adding more charcoal/wood and by opening or closing the damper / smoke stack.
4. Once the desired temperature is achieved, place the food in the cooking chamber. Continue to monitor the temperature as the food smokes/cooks. For the best heat and smoke flow, open the smoke stack and close the Fire Box damper. Keep the charcoal damper on the front of the grill closed when smoking/indirect cooking. At 225 to 250 degrees, it will take approximately 30 minutes per pound to cook the food. Time will vary depending on the temperature at which food is smoked/cooked. The level of desired doneness will also affect the cooking time.
5. For best results, try to maintain a constant temperature inside the cooking chamber by adding charcoal wood as necessary and adjusting the damper openings. Check the internal food temperature periodically by inserting a meat thermometer into the Food. Use caution when checking the food temperature to avoid injury.
6. Once the food has reached the desired temperature, remove from cooking chamber and let stand 30 minutes. The USDA Standard temperature chart for properly cooked meat can be found at the back of this manual.

### Rules for smoking:

We recommend that most smoking be done at 225 to 250 degrees. We also recommend the use of an oven thermometer to verify the inside temperature of your smoker and a meat thermometer to check the temperature of the meat. The heat indicator will give you an indication of the temperature inside the smoker but it is best to use an oven thermometer to ensure that the temperature is correct. A good rule of thumb for smoking is to cook the meat for 30 to 45 minutes per pound. As the weight of the meat increases so will the amount of time needed. For instance, 2 or 3 pounds of meat might take 30 minutes per pound or while 7 or 8 pound will require closer to 45 minutes per pound. Refer to the temperature chart in the Assembly Manual to make sure that the meat is at an acceptable temperature.

### Types of wood to use for smoke:

1. What type of hardwood should you use?  
Always use a hardwood that has been seasoned for at least 6 months.
2. Can I use Oak pallets?  
NO, because pallet wood is dried out before it is used for making pallets. You need the natural moisture in wood to create flavor in your smoke.
3. Can I use Pine, Cedar or any other wood that smells good?  
NO, never use any resin woods.

### What are the main items I need to smoke meats?

1. Internal meat thermometer .  
An internal meat thermometer is a must to cook large pieces of meat to make sure it is done internally.  
Cooked Ham-140 degrees  
Ham, Beef-Med, Ground Beef- 160 degrees  
Veal, Lamb, Pork, Beef-Well done – 170 degrees  
Poultry- 180 degrees
2. Good tongs or meat hook.  
Use a heavy-duty set of tongs to rotate meat in the smoker because in some cases you may be smoking a very large cut of meat. I prefer a meat hook for ease of use and it does not knock any rub or sauce off of the meat.
3. Good oven mitts.  
Heavy-duty mitts will assist you in moving hot smoker racks and large pieces of meats and assist in adding water and wood chips.
4. Aluminum foil.  
When the outside color of your meat product is at your desired color or look to suit your taste, wrap meat product in aluminum foil to keep any more wood resins from turning your meat any darker.

## Operation: Smoking food

### Classic Recipes:

#### Pork

##### ***Smoked Pork Tenderloin***

Take outside wrapper off of meat and wash thoroughly in cold water. Place tenderloin on a paper towel to soak up excess water. Rub your favorite pork rub on the loin (we recommend Head Country Pork seasoning). Preheat smokers to 225 degrees and place loin in the center of the smoker. Cook until internal meat temperature reaches 165 degrees. Take out of smoker and let stand on the cutting platter until meat reaches 170 degrees serving temperature. Slice like bread in 1/4" pieces and it will melt in your mouth.

##### ***Pork Ribs- Baby Backs or Spare Ribs***

Take ribs out of wrapper and drain all liquid off of the ribs and then wash in cold water. Place on cutting board and cut away any excess fat or skin from the bottom of ribs. Turn ribs with bone side up and peel the membrane from the back of the bone until all is gone. Rub your favorite pork rub on both sides of the ribs (we recommend Head Country Pork seasoning). Preheat smoker until it reaches 225 degrees and place rib bone side down in smoker. After one hour, turn the rib over with bone side up and cook for one hour. After 2 1/2 hours, depending on the color of the rib you like, pour a one-inch wide strip of your favorite BBQ sauce down the length of the rib and wrap tightly in aluminum foil. Place back in smoker and check every 15 to 20 minutes to see if the rib bones separate by using your finger to pull them apart. If they pull apart with ease your ribs are done. Take out of smoker and let stand on serving platter until cool enough to eat. Total cooking time should not be more than 3 1/2 hours total.

#### Beef

##### ***Smoked Beef Brisket***

Select a 6 to 8 lb. packer trimmed brisket that has a little marble to it but not too much. Feel free to trim as much fat as desired. Use your favorite beef rub (we recommend using Head Country All-Purpose rub) and rub it on liberally. Heat the smoker to 225 degrees and place the brisket in the smoker for 3 hours. Place brisket in an aluminum foil pan and pour approximately 8oz. Of Allegro over the brisket. Cover the pan tightly with aluminum foil and continue cooking until internal meat temperature reaches 165 to 170 degrees. Take pan out of the smoker and let brisket stand. Remove brisket from pan and cut 1/4" slices against the grain. Use juice from pan to pour over sliced meat or for dipping.

##### ***Prime Rib***

Select a 6 to 8 lb prime rib (we like the bone on). Rub the prime rib with your favorite beef rub (we recommend using Head Country All-Purpose rub). Pre-heat the smoker to 225 degrees and place the prime rib in the smoker. After 3 hours, place the prime rib in aluminum foil pan and cover with aluminum foil. When internal meat temperature reaches 145 degrees take out of smoker and let stand until your desired doneness is reached. Medium rare is 155 to 160 degrees. While standing, the temperature of the meat will rise internally up to 10 degrees. Slice prime rib to desired thickness and serve with juice from the pan in which it was cooked.

## **Operation: Smoking food**

### **Classic Recipes: (Continued)**

#### **Fish**

##### ***Smoked Halibut***

Select a nice fresh 3/4" thick filet. Wash filet thoroughly in cold water and lay on paper towel until water is not visible. Melt a whole stick of butter in the microwave and sprinkle a liberal amount of Dill weed in the melted butter. Lay filets on Aluminum foil and fold a lip around edges to contain the butter. With a basting brush, brush melted butter and dill weed mixture on both sides of the fish filet. Preheat smoker to 225 degrees and place fish in the smoker. Check the filets every 15 minutes for visible moist look on filets. Brush with butter and dill weed mix when needed. Fish should start to flake in about 45 minutes. When fish flakes very easy take out of smoker and serve.

#### **Poultry**

##### ***Smoked Chicken***

Chicken breasts and thighs are my favorite. Take chicken parts out of package and wash thoroughly and place on paper towel to dry. Sprinkle Head Country Original rub on both sides of chicken parts. Preheat smoker to 225 degrees and place chicken parts in smoker. After 1/2 hour turn chicken over. With your internal temperature gauge, check internal temperature by pushing temperature probe into the meat nearest the bone. When temperature reaches 180 degrees chicken is done. You may brush your favorite BBQ sauce on the chicken during the last 15 minutes of your cooking process to spice it up.

##### ***Smoked Turkey***

Select a 12 to 15 lb. turkey for best results in a smoker. Take the turkey out of the package and remove all internal parts and packaging. Wash turkey thoroughly and place it on paper towel to dry. Rub olive oil inside and out on the turkey and apply Head Country Original Rub inside body cavity and on the outside skin. Preheat smoker to 225 degrees and place turkey in smoker. You may baste with butter for more moisture, if you like. When turkey skin reaches your desired color, remove turkey from smoker, place in aluminum foil pan and cover with aluminum foil tightly. Place covered pan in smoker and continue cooking at 225 degrees. Check internal meat temperature, where the thigh meets the side of the turkey, every half hour for doneness. Turkey should take around 45 minutes per lb to reach 180 degrees serving temperature.

## Operation: Cooking

### Temperature Chart

Refer to this USDA Standard chart for properly cooked meat temperature.

**IMPORTANT:** Measure the meat temperature using a meat probe thermometer. The heat indicator on the smoker gives the heat temperature inside the smoker cabinet, but is not an accurate measurement of the meat temperature.

### Temperature on Meat Thermometer

Beef Roasts, Beef Brisket	3-4 lbs.	4-5 hours	140° rare
Lamb Roasts, Venison	5-7 lbs.	5-6 hours	160° medium
Large cuts of Game	7-9 lbs.	7-10 hours	170° well done
Pork Roasts	3-4 lbs. 5-8 lbs.	5-6 hours 7-8 hours	170° 170°
Pork/Beef Ribs	Full grill	4-6 hours	Meat pulls from bone
Pork Chops	Full grill	4-6 hours	Meat pulls from bone
Sausage Links	Full grill	4-5 hours	170° for fresh sausage
Ham, Fresh	10 lbs.	7-8 hours	170°
Ham, Cooked	All sizes	3-4 hours	130°
Chicken (Cut up or split)	1-4 fryers, cut up or split	4-5 hours	180°/leg moves easily in joint
Chicken (Whole)	1-4 fryers	5-6 hours	180°/leg moves easily in joint
Turkey (Unstuffed)	8-12 lbs.	7-8 hours	180°/leg moves easily in joint
Fish, small whole	Full grill	2-3 hours	Flakes with fork
Fish, filets, steak	Full grill	1-3 hours	Flakes with fork
Duck	3-5 lbs.	5-6 hours	180°/leg moves easily in joint
Small game birds	Full grill	4-5 hours	180°/leg moves easily in joint

## Limited Warranty



This Smoke Hollow ® Grill is guaranteed against broken or damaged parts at time of purchase. All parts carry a 1-year limited warranty. Paint is guaranteed to be free of defects for 90 days except for rust, which may appear after repeated use.

This warranty does not cover damage or issues related to neglect, abuse, or modifications to the product. Repair labor is not covered.

All parts that meet the warranty requirements will be shipped at no-charge via the discretion of the Customer Service Department (ground shipments, US Mail, or Parcel Post Only). Any special handling charges (i.e. Second Day, Overnight, etc.) will be the responsibility of the consumer.

All warranty claims apply only to the original purchaser and require a proof of purchase verifying purchase date. Do not return parts to our address without first obtaining a return authorization number from our customer service.

This service is available by calling 866-475-5180, 8:30am to 4:30pm, Central Time, Monday through Friday, or write to Outdoor Leisure Products, Inc., 5400 Doniphan Drive, Neosho, MO 64850.

This warranty may give you specific legal rights that vary by state.

Outdoor Leisure Products, Inc  
5400 Doniphan Drive  
Neosho, MO 64850  
[www.olp-inc.com](http://www.olp-inc.com)

©2014 Outdoor Leisure Products, Inc. Smoke Hollow ® and the Smoke Hollow ® logo are trademarks of Outdoor Leisure Products, Inc. and are not to be used without express permission by Outdoor Leisure Products, Inc.