

Owner's Manual

POWERTEC PRO

6" BENCH JOINTER **WITH BUILT-IN DUST COLLECTION**

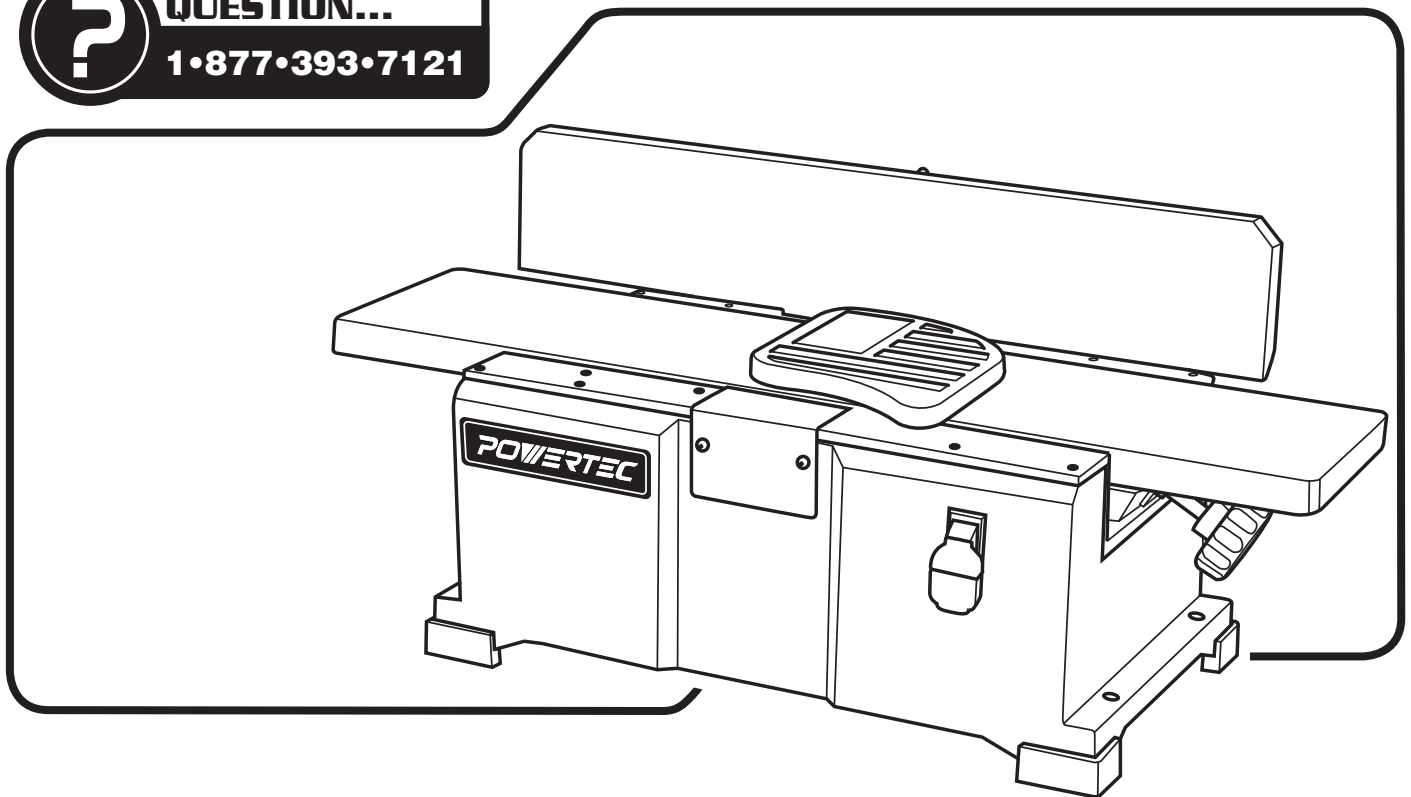

Visit us on the web at www.southerntechllc.com



You will need this manual for safety instructions, operating procedures, and warranty. Put it and the original sales invoice in a safe, dry place for future reference.

TABLE OF CONTENTS

SECTION PAGE



SAFETY RULES

1

Work Preparation
Work Area Preparation
Tool Maintenance
Tool Operation



ASSEMBLY

2

Unpackaging
Attach Fence Support
Install Fence
Attach Dust Collection Bag
Mount Jointer
Power Source
Grounding Instructions
Extension Cords
Motor
Electrical Connections



OPERATION

6

Description
Specifications
Safety Precautions
Position Fence
Check Blade Outfeed Table Alignment
Adjust the Height of the Cutterhead Blades
Adjust the Depth of Cut
Measure the Depth of Cut
Check the Blade Guard
On-Off Switch
Feed Direction
Feed the Workpiece
Use Hold Down/Push Blocks
Bevel and Chamfer



MAINTENANCE

10

Replace the Blades
Sharpening the Blades
Replace the Fan Belt
Replace the Drive Belt
Inspect and Replace Motor Brushes
General Maintenance and Lubrication
Keep Tool in Repair



TROUBLESHOOTING

12



PARTS ILLUSTRATION & LIST

13



WARRANTY

15

PRODUCTION SPECIFICATIONS

Voltage.....	120
Amps.....	12
Hertz.....	60
Phase.....	Single
Cutter Head Speed.....	10,000 RPM
Table Size.....	28-1/2 x 6-1/4 in (72.4 x 15.9 cm)
Blade Width.....	6-1/8" (15.6 cm)
Maximum Depth of Cut.....	1/8" (3 mm)
Cuts per Minute.....	20,000
Dust Collection Port.....	2-1/2" (62 mm)

 **WARNING**

For your own safety, read and understand all warnings and operating instructions before using any tool or equipment.

 **WARNING**

Some dust created by operation of power tool contains chemicals known to the State of California to cause cancer, birth defects or other reproductive harm. To reduce your exposure to these chemicals: work in a well ventilated area and work with approved safety equipment. Always wear OSHA/NIOSH approved, properly fitting face mask or respirator when using such tools.

 **WARNING**

Failure to follow these rules may result in serious personal injury. Remember that being careless for even a fraction of a second can result in severe personal injury.

WORK PREPARATION

- Wear proper apparel. Do not wear loose clothing, gloves, neckties, rings, bracelets or other jewelry which may get caught in moving parts of the tool.
- Nonslip protective footwear is recommended. ^(new bulklet) Wear protective hair covering to contain long hair.
- Wear eye and hearing protection. Always use safety glasses. Eye protection equipment should comply with ANSI Z87.1 standards. Hearing equipment should comply with ANSI S3.19 standards.
- Wear face mask or dust mask if operation is dusty.
- Be alert and think clearly. Never operate power tools when tired, intoxicated or when taking medications that cause drowsiness.

WORK AREA PREPARATION

- Keep work area clean. Cluttered work areas and benches invite accidents.
- Work area should be properly lighted.
- Do not use the machine in a dangerous environment. The use of power tools in damp or wet locations or in rain can cause shock or electrocution.
- Three-prong plug should be plugged directly into properly grounded, three-prong receptacle.
- Use the proper extension cord. Make sure your extension cord is in good condition and should have a grounding prong and the three wires of extension cord should be of the correct gauge.
- Keep children and visitors away. Your shop is a potentially dangerous environment. Children and visitors can be injured.
- Make your workshop childproof with padlocks, master switches or remove switch keys to prevent any unintentional use of power tools.

TOOL MAINTENANCE

- Turn the machine "OFF", and disconnect the machine from the power source prior to inspection.
- Maintain all tools and machines in peak condition. Keep tools sharp and clean for best and safest performance.
- Follow instructions for lubricating and changing accessories.
- Check for damaged parts. Check for alignment of moving parts, binding, breakage, mounting and any other condition that may affect tool's operation.
- Poorly maintained tools and machines can further damage the tool or machine and/or cause injury.
- A guard or any other part that is damaged should be repaired or replaced. Do not perform makeshift repairs.

TOOL OPERATION

- Avoid accidental start-up. Make sure that the tool is in the "OFF" position before plugging in.
- Use the right tool for your job. Do not force your tool or attachment to do a job for which it was not designed.
- Disconnect tool when changing parts.
- Don't force the workpiece on the machine. Damage to the machine and/or injury may result.
- Never leave tool running unattended. Turn the power off and do not leave tool until it comes to a complete stop.
- Do not overreach. Loss of balance can make you fall into a working machine, causing injury.
- Never stand on tool. Injury could occur if the tool tips, or if you accidentally contact the cutting tool.
- Know your tool. Learn the tool's operation, application and specific limitations before using it.
- Use recommended accessories. Use of improper accessories may cause damage to the machine or injury to the user.
- Handle workpiece correctly. Keep hands away from moving parts.
- Turn tool off if it jams. (remove extra period)

CAUTION: Think safety! Safety is a combination of operator common sense and alertness at all times when tool is being used.

 **WARNING**

Do not attempt to operate tool until it is completely assembled according to the instructions.

UNPACKAGING

Refer to Figure 1.

The machine is shipped complete in **one** container.

Carefully unpack the machine and all loose items from the shipping container. Fig 1 illustrates the machine and all loose items.

Check for shipping damage. A claim must be filled with carrier if damage has occurred.

- A Joints bed assembly
- B Fence
- C Fence support
- D Fence bracket assembly
- E Locking plate assembly
- F Fence sliding handle with spacer
- G Push blocks (2)
- H Fence tilting handle with spacer
- I Dust chute
- J Dust Collection Bag
- K Dust Collection Clamp
- L Dust Collection Wire

Hardware bag includes:

8-1, 25 x 25 mm socket head bolts (6)

8mm lock washer (6)

4 and 6mm hex wrench

6-1.0 x 25mm pan head screw

Figure 1 - Unpacking

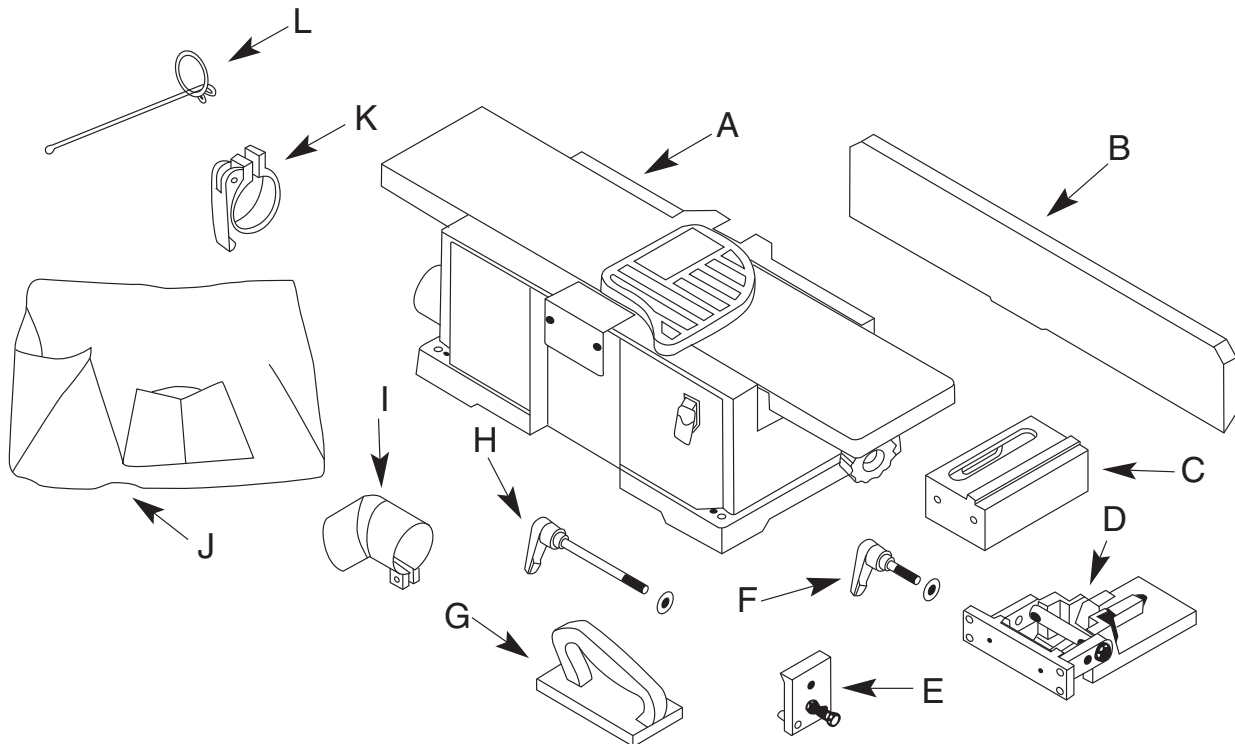

ATTACH FENCE SUPPORT

Figure 2-1



Turn the switch to the OFF position and disconnect the machine from power source.

- Use two socket head bolts and washers to lock the fence support to the jointer.
- Insert locking plate assembly (E) into fence support (C). Position locking plate so that the two pins are against the bottom edge of the fence support.
- Secure the locking plate in position with fence sliding handle (F) and spacer.

Figure 2-1 - Attach Fence Support

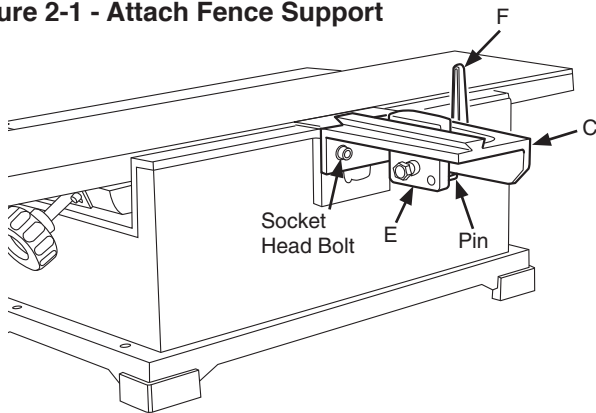

INSTALL FENCE

Figure 2-2 and 2-3

- Use the four socket head bolts and washers to attach fence (B) to Fence bracket assembly (D).

Figure 2-2 - Assembling Fence and Fence Bracket

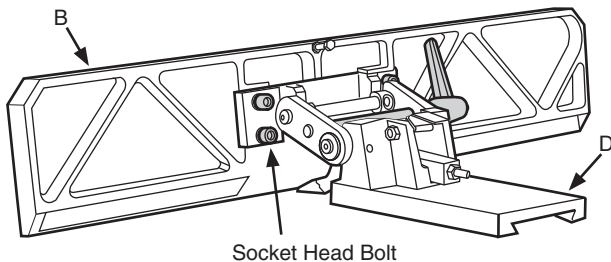

- Slide fence and bracket (B+D) over and onto dovetails of support and locking plate (C+E). (Figure 2-3)

Figure 2-3 - Assembling Fence and Fence Bracket

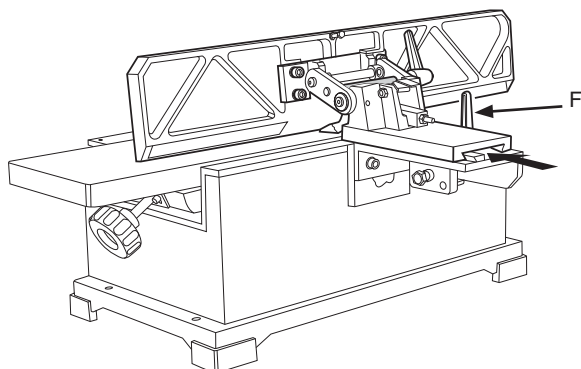

- Slide fence forward so that the fence contacts the cutterhead guard. At this position the cutterhead is completely covered by cutterhead guard.
- Install fence tilting handle (H) with spacer through right link and thread into left link. (Figure 3)

Figure 3 - Attach Fence Assembly

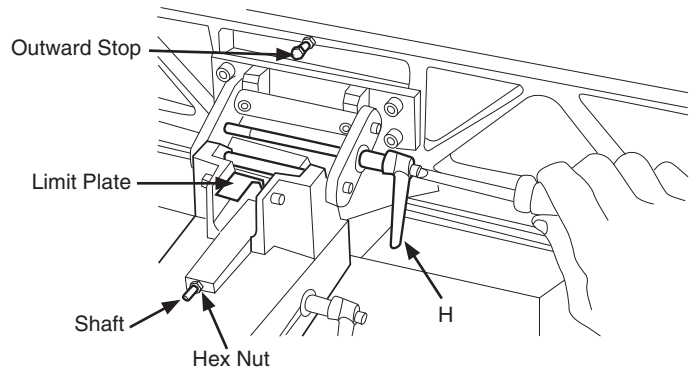

ATTACH DUST COLLECTION BAG

Refer to Figure 1 and 4

- Install the Dust Chute (I) by slipping it over the Dust Port. Tighten the screw on the Dust Chute (I).
- Insert Dust Bag Wire (L) through a small hole on the sleeve of Dust Bag (J).

Figure 4 - 1

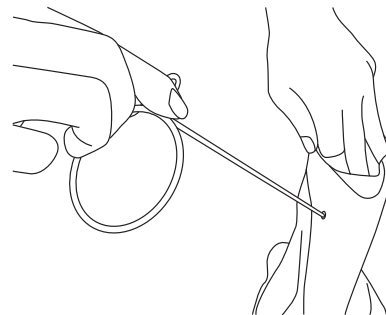

- Draw the open end of Dust Bag (J) sleeve through the ring of Dust Bag Wire (L).

Figure 4 - 2

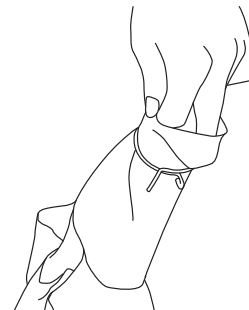

- Place Clamp (K) over Dust Bag (J) Sleeve.

Figure 4 - 3

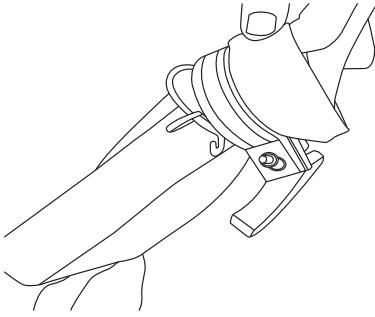

- Slide Sleeve with Clamp (K) and Dust Bag Wire (L) Ring over Dust Chute (I).

Figure 4 - 4

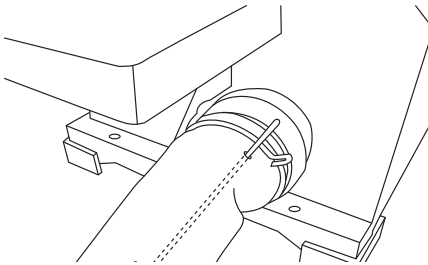

- Secure Dust Bag (J) in position. Rotate the handle on the Clamp (K) to adjust the clamp size so it can slide over the Dust Chute (I). Press the handle to tighten the Clamp (K).
- The Dust Bag (J) should be secured on the Dust Chute (I) now.

MOUNT JOINTER

- The machine must be installed in a well-lighted area with correct power supply.
- The machine can be installed on either a workbench or a tool stand by using bolts, lock washers, and hex nuts.
- The machine must be bolted to a firm and level surface.
- There must be enough clearance for the moving workpiece during operation. There must be enough room for safety operation of the machine.
- Figure 5 shows the base dimensions and mounting holes.

Figure 5 - Jointer/Planer Foot Print

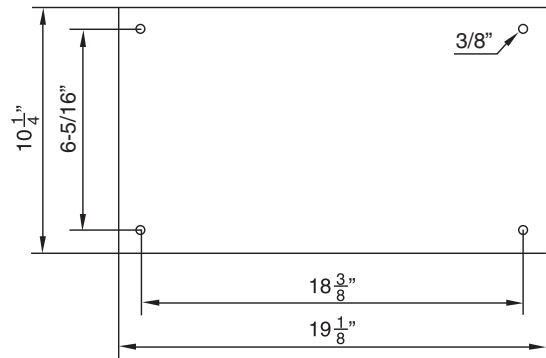

POWER SOURCE

⚠ WARNING

Do not connect to the power source until the machine is completely assembled.

The machine is wired for 120 volts, 60 HZ alternating current. Before connecting the machine to the power source, make sure the switch is in the "OFF" position. Running the unit on voltages which are not within range may cause overheating and motor burn-out. Heavy loads require that voltage at motor terminals be no less than the voltage specified on nameplate.

- Power supply to the motor is controlled by a locking rocker switch. Remove the key to prevent unauthorized use.

GROUNDING INSTRUCTIONS

⚠ WARNING

Improper connection of equipment grounding conductor can result in the risk of electrical shock.

- The machine should be grounded while in use to protect operator from electrical shock.
- In the event of an electrical short circuit, grounding reduces the risk of electrical shock by providing an escape wire for the electric current.
- This machine is equipped with an approved 3-conductor cord rated at 150V and a 3-prong grounding type plug (Figure 6) for your protection against shock hazards.
- Grounding plug should be plugged directly into a properly installed and grounded 3-prong grounding-type receptacle, as shown (Figure 6)
- The plug must be plugged into an outlet that is properly installed and grounded in accordance with all local codes and ordinances.
- Check with a qualified electrician or service personnel if these instructions are not completely understood or if in doubt as to whether the tool is properly grounded.
- Do not modify plug provided. If it will not fit in outlet, have proper outlet installed by a qualified electrician. Use only 3-wire extension cords, that have 3-prong grounding type plugs and matching 3-conductor receptacles that accept the machine's plug, as show in Figure 6

Figure 6 - 3-Prong Receptacle

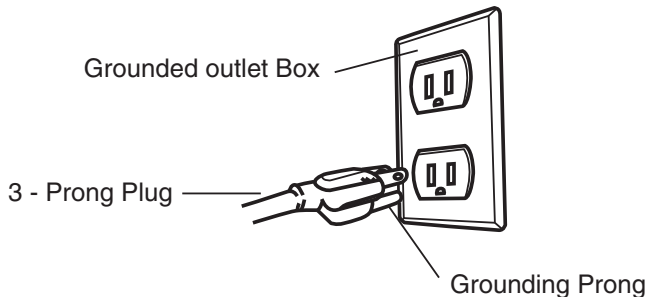

WARNING

Do not permit fingers to touch the terminals of plug when installing or removing from outlet.

- Inspect tool cords periodically, and if damaged, have repaired by an authorized service facility.
- The conductor with insulation having an outer surface that is green with or without yellow stripes is the equipment-grounding conductor. If repair or replacement of the electric cord or plug is necessary, do not connect the green (or green and yellow) wire to a live terminal.

A temporary 3-prong to 2-prong grounding adapter (see Figure 7) may be used to connect this plug to a matching 2-conductor receptacle as shown in figure 7. The temporary adapter should be used only until a properly grounded outlet can be installed by a qualified electrician.

Figure 7 - 3-Prong Receptacle

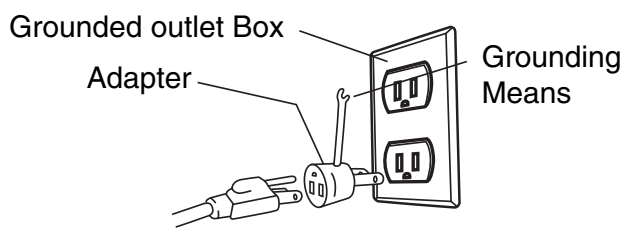

In Canada, the use of temporary adapter is not permitted by the Canadian Electric Code. Where permitted, the rigid green tab or terminal on the side of the adapter must be securely connected to a permanent electrical ground such as a properly grounded water pipe, a properly grounded outlet box or a properly grounded wire system.

- Many cover plate screws, water pipes and outlet boxes are not properly grounded. To ensure proper ground, grounding means must be tested by a qualified electrician.

EXTENSION CORDS

Use proper extension cords. Make sure the extension cord is in good condition. Use only 3-wire extension cords have 3-prong grounding type plugs and 3-pole receptacles which accept the tool plug. When using an extension cord, make sure to use one heavy enough to carry the current of the machine. An undersized cord will cause a drop in the voltage, resulting in loss of power and overheating. Use the table to determine the minimum wire size (A.W.G.) extension cord.

Extension Cord Length

Wire Size	A.W.G.
Up to 25 ft.	18
25 to 50 ft.	16

NOTE: Using extension cords over 50 ft. long is not recommended.

MOTOR

Jointer is equipped with a 12 Amps motor. The universal motor has the following specifications.

Voltage	120
Amps	12
Hertz	60
Phase	Single
Motor	20,000 RPM

ELECTRICAL CONNECTIONS

WARNING

Turn the switch off and disconnect the machine from power source before any repair or maintenance work.

Figure 8 - Wiring Schematic

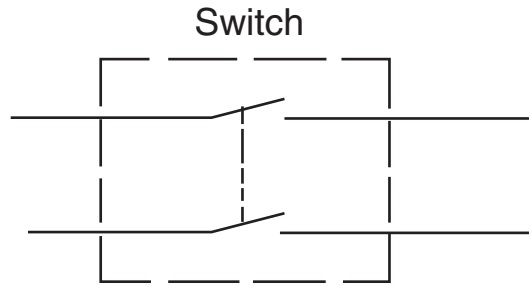

- Some electrical wiring and connection work must be performed by a qualified electrician in accordance with local regulations.
- Scheme of the motor and electric wiring inside this machine is shown Figure 8.
- There is a green grounding wire fastened to the frame of the machine to provide Shock Protection. Do not disconnect the Grounding Wire from the frame.
- The Motor is rated for used at 120 Volts.
- Connect this machine to 3-Conductor Power outlet with appropriate rating only.
- Use only 3-pronged Extension Power Cord with appropriate rating with this machine.
- When change the power cord, use only 3-pronged Power Cord with appropriate rating.
- The Power switch is a Single Pole Rocker switch with Locking Mechanism. Remove the Key when not in use to prevent accidents.



DESCRIPTION

This jointer is used to surface the faces and edges of wood to produce a flat surface. The jointer features cast iron tables, a built-in dust blower for chip removal and a balanced guide fence for the cutting angles at 90°, 45° (inward) and 45° (outward).

SPECIFICATIONS

Max. cut of depth.....	1/8"
Max. width of cut.....	6-1/8"
Cutterhead speed.....	10,000 RPM
Cuts per minute.....	20,000
Table size.....	6" W x 24" L
Cutterhead.....	2-Kinfe, Straight Knife
Cutterhead diameter.....	1-7/8"

WARNING

For your own safety, read the operating manual and all the safety instructions before using the jointer.

SAFETY PRECAUTIONS

- Be aware of general power tool safety. Make sure all the safety rules are understood.
- Disconnect the machine from power source whenever adjusting or replacing any parts.
- Do not plug in unless switch is in the "OFF" position.
- Keep hands away from all moving parts.
- Wear eye protection or face shield during operation.
- Make sure all guards are attached and securely fastened. Keep cutterhead and blade guards in proper working condition.
- Make sure all mobile parts move freely and are free from interference.
- Keep blades sharp, aligned and properly attached cutterhead.
- Properly secure the blades in the cutterhead.
- Never turn the machine "ON" with the workpiece contacting the cutterhead.
- Never make cuts deeper than 1/8" (3.2mm) deep to prevent kickback.
- Do not force cut. Slowing or stalling will overheat the motor.
- Do not perform jointer operations on workpiece shorter than 10", narrower than 3/4" or less than 1/2" thick.
- Properly support long or wide workpieces.
- Use hold-down/push blocks for jointing any workpiece lower than the fence.
- Do not perform a workpiece that is warped, contains knots, or is embedded with foreign objects (nails, staples, etc) to prevent kickback.
- Do not feed a workpiece into the outfeed end of the machine.
- Do not attempt to perform an abnormal or little-used operation without study and the use of adequate hold-down/push blocks, jigs, fixtures, stops, etc.

- Do not allow anyone to stand or cross in line of cutterhead rotation. Kickback or thrown debris will travel in this direction.
- Turn switch off and disconnect power whenever jointer is not in use.
- Keep jointer maintained. Follow maintenance instructions.

POSITION FENCE

WARNING

Turn the switch to the "OFF" position and disconnect the machine from power source.

The fence can be adjusted to any angles between 45° inward and 45° outward. There are three positive stops: 90°, 45° inward, and 45° outward. Refer to figure 9 when adjust the fence

Figure 9 - Limit Stops

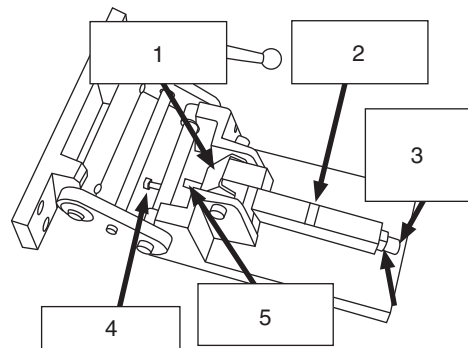
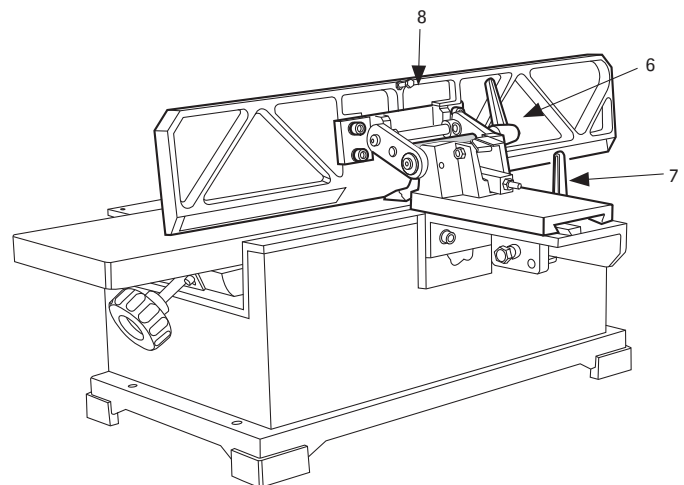

Figure 10



To set the 90° stop:

- Position the fence on the bed. Place sliding handle (7) in locked position. Loosen the fence tilting handle (6).

- Push the Limit Block Shaft (3) toward the fence. Place the Limit plate (1) of the Fence Bracket Assembly into the Limit Block Rear Slot (2).
- Pull the fence ~~toward~~ perpendicular to the table (90°) position. The fence will hit and be stopped by Limit Block Shaft (3). Now tighten the Fence Tilting Handle (6). The Fence is at 90° position.

To set the inward 45° stop:

- Position the fence on the bed. Place sliding handle (7) in locked position. Loosen the fence tilting handle (6).
- Pull the top of the fence toward the table. It will hit and be stopped by the inward stop bolt (4). Now tighten the fence tilting handle (6). The fence is at inward 45° position.

To set the outward 45° stop:

- Position the fence on the bed. Place sliding handle (7) in locked position. Loosen the fence tilting handle (6).
- Pull out the limit block shaft (3) so it will not limit outward movement of the fence.
- Pull the top of the fence outward. It will hit and be stopped by the outward stop bolt (8). Now tighten the fence tilting handle (6). The fence is at outward 45° position.

CHECK BLADE OUTFEED TABLE ALIGNMENT



Turn the switch to the "OFF" position and disconnect the jointer from the power source.

Do not touch the blade cutting edge at any time.

The blades have been adjusted in the factory and should require no adjustment. Nevertheless, the blades can become out of alignment during shipping and handling. For accurate cutting, the blades must be at the same level with the outfeed table.

- To adjust the blades, position a straight edge on the outfeed table and have it extend over the cutterhead.
- Gently rotate the cutterhead under the straight edge. The blades should just touch the straight edge by a hair. The blades may brush the straight edge and pull it forward slightly (No more than 1/8" on each blade pass). If a blade does not touch the straight edge at all, it is too low. If a blade pulls forward the straight edge more than 1/8", it is too high.
- Check blade height at both ends of the blade to see if it is level from side to side.
- Check each blade using the same procedure.

Figure 11 - Cutterhead Alignment Setup

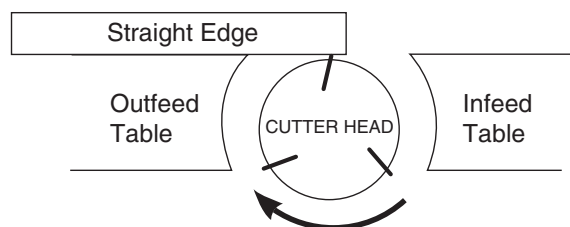

ADJUST THE HEIGHT OF THE CUTTERHEAD BLADES:



Turn the switch to the "OFF" position and disconnect the machine from the power source.

Refer to Figure 12 and 13

- Pull open the blade guard (4) and block it in open position with a piece of wood (3). Now the cutterhead (1) is fully exposed.
- Locate the blade lock screws (5) and jack screws (6) on the cutterhead (1)
- Loosen the four blade lock screws (5) and the two jack screws (6) with enclosed 4mm hex wrench.
- Use a wood block to push down the blade (7) gently until the blade edge is slightly below the straightedge (see Figure 11).
- Turn each jack screw (6) clockwise, 1/8 of a turn at a time, until the edge of the blade just touches the straight edge by a hair. Adjust the blade at both ends so they are even from side to side.
- With the screws are partially loose, gently rotate the cutterhead (1) under the straight edge. The blades (7) may brush the straight edge and pull it forward slightly (No more than 1/8" on each blade pass). If a blade (7) does not touch the straight edge at all, it is too low. If a blade pulls forward the straight edge more than 1/8", it is too high. Adjust the jack screws until the blade height is correct at both ends.
- Tighten each blade lock screws (5) and jack screws (6) firmly.
- Adjust each blade using the same procedure.
- Return the blade guard (4) to its original position.

Figure 12 - Block Blade Guard

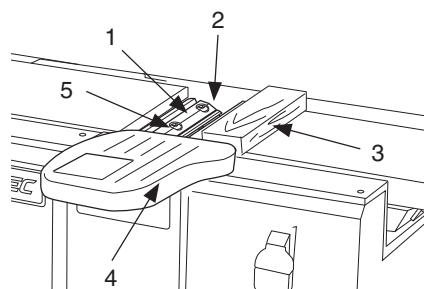
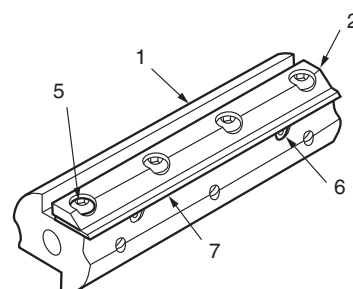

Figure 13 - Cutterhead Illustration



ADJUST THE DEPTH OF CUT

- This jointer can cut workpiece from very thin to 1/8" deep. Do not attempt to cut more than 1/8" deep. For hardwood, the recommended depth is 1/16" or less in order to reduce the danger of Kickback.
- For deeper cut, lower the infeed table by turning the hand knob counterclockwise.
- For thinner cut raise the infeed table by turning the hand knob clockwise.

Figure 14 - Depth of Cut

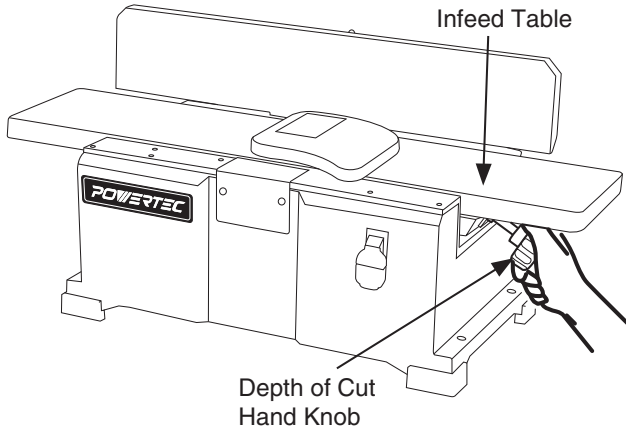

MEASURE THE DEPTH OF CUT

Rest a straight edge on the outfeed table and extend it over the infeed table. The distance from the top of the infeed table to the bottom of the straight edge is the depth of cut.

Figure 15 - Depth of Cut

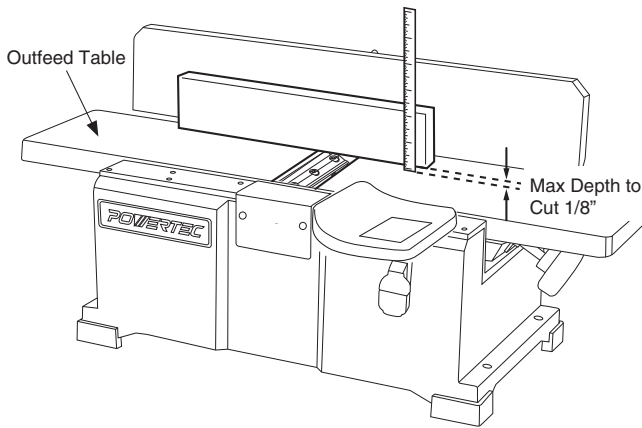

CHECK THE BLADE GUARD

- Slide open the blade guard all the way. Then release it. The guard should return to the original close position automatically. If the blade guard does not move appropriately, the spring may need adjustment or replacement.
- The blade guard must be in place and function properly at all time to provide adequate protection for both the machine operators and the cutterhead assembly.

ON-OFF SWITCH

The ON/OFF switch is located on the jointer base. To turn the jointer ON, pull the switch to the up position. To turn the sander OFF, push the switch to the down position.

NOTE: When the machine is not in use, the switch should be locked in the "OFF" position to prevent unauthorized use.

- To lock the machine, turn the switch to the "OFF" position. Pull the key out. The switch can't be turned on without the key.
- If the key is removed when the switch is at the "ON" position, the switch can be turned off but cannot be turned on again.
- To unlock, place the key into the slot on switch unit until it snaps.

Figure 16 - On-Off Switch

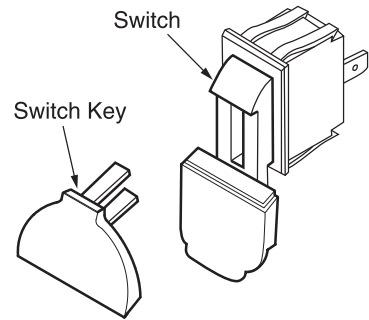

FEED DIRECTION

- The feed direction is important in operation of the jointer machine. Feed the workpiece in direction that the grain pointing downward and toward the infeed table. This is called "With The Grain". With the gain produces a smooth finish surface and is less likely to cause kick back.
- Feeding the workpiece with the grain pointing toward the outfeed table, "against the grain", will increase the incidence of kickback and rough on the wood surface, Tear-Out.

Figure 17 - Direction of Feed

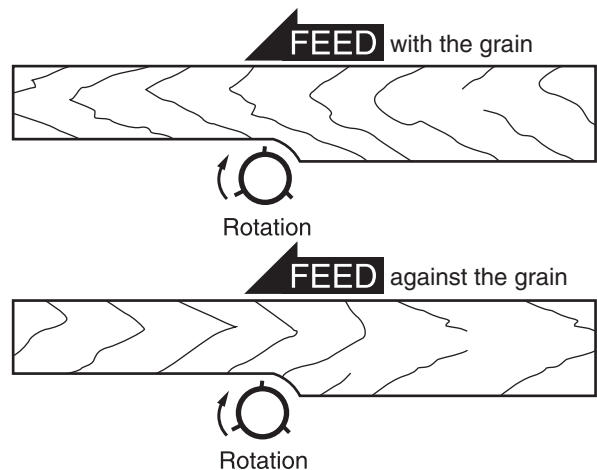

FEED THE WORKPIECE

- This jointer machine is designed to process natural wood fiber only . Never use plastics, metal, laminated articles, particle board, plywood, MDF or other synthetic materials on this machine.
- Never process a workpiece that is shorter than 10", narrower than 3/4", or less than 1/2" thick. As this can cause severe injuries to your hands by getting into the rotating cutterhead accidentally.
- Never feed a workpiece that has large knots, loose knots, or foreignbodies like wires, nails, staples, to prevent kickback, blade damage, or injuries to the machine operator.
- To feed the workpiece through the cutterhead, hold the board firmly down on the infeed table and against the fence. Use Hold Down Block if indicated, see next section.
- Keep fingers close together to prevent injury.
- Feed the workpiece toward the cutterhead slowly at a constant speed while holding the workpiece firmly. Avoid any stop during the process as this may cause an uneven step on the workpiece.
- Depending on the length of workpiece, you may need to alternate your hands during the process. As soon as the trailing hand passes the cutterhead, move the leading hand to the back of the trailing hand. Now the trailing hand becomes the leading hand and the leading hand becomes the trailing hand. Repeat this until the entire workpiece passes through the cuttinghead.
- While alternating your hands, try to keep firm control of the workpiece and keep the feed speed constant.
- Surface plane on the jointer – The concave face to the workpiece is the surface planed flat with the jointer.
- Edge jointer on the jointer – The concave edge of the workpiece is jointed flat with the jointer.

Figure 18 - Feeding board

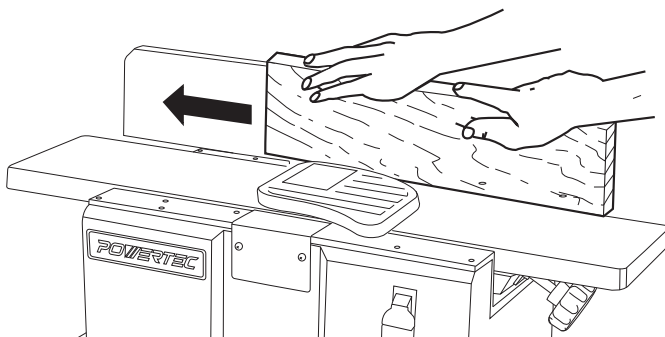
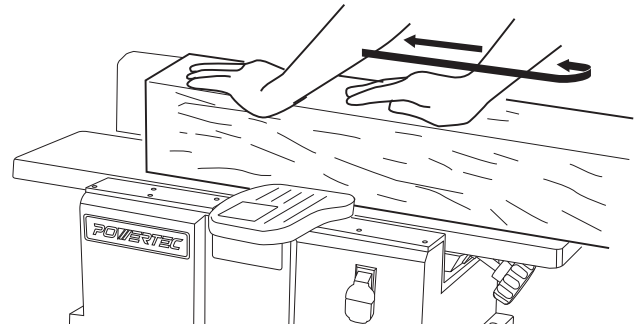

Figure 19 - Guiding Workpiece



USE HOLD DOWN/PUSH BLOCKS

- Use Hold Down Block or Push Blocks when process any workpiece that is lower than the fence height.
- Position the Hold Down/Push Blocks on the top of the workpiece and make sure there is good contact and firm control during the process. Push Hold Down/Push Blocks down firmly against the workpiece on the table. Proceed to feed the workpiece toward cutterhead.
- When jointing or planing a workpiece narrower than the push blocks, tilt the push blocks so that it clears the cutterhead guard while feeding.

Figure 21 - Feeding with Push Blocks

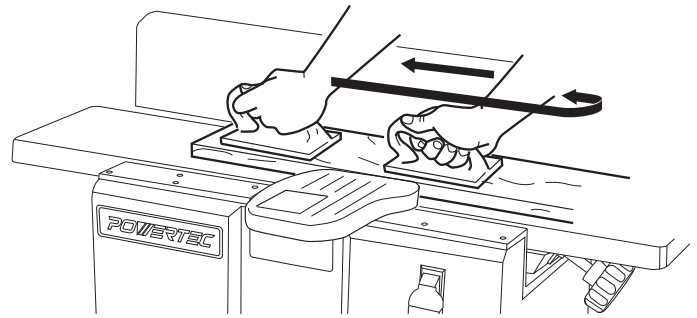

BEVEL AND CHAMFER

The fence can be set from 45° inward to 45° degree outward. Beveling is cutting the entire edge of a workpiece at an angle. Chamfering is removing only a small corner of the edge. Both can be achieved by appropriately adjusting the Fence Angel and Depth of Cut.

Figure 22 - Beveling and Chamfering



WARNING

Turn the switch to the "OFF" position and disconnect the jointer from power source before any maintenance work.

REPLACE THE BLADES

- Pull open the blade guard (4) and block it in open position with a piece of wood (3). Now the cutterhead (1) is fully exposed.

Figure 23 - Block Blade Guard

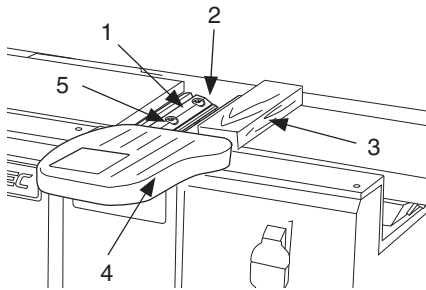
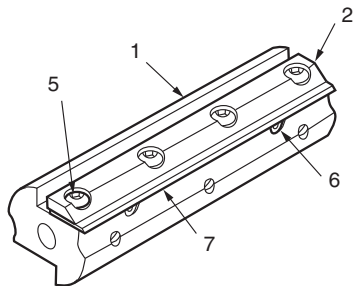

Figure 24 - Cutterhead Illustration



- Use the enclosed 4mm hex wrench to loosen and remove all blade lock screws (5).
 - Remove blades (7) and blades clamp (2).
 - Put together the blade clamp (2) and the new replacement blade and replace them onto the cutterhead (1).
 - Loosely secure blade (7) and blade clamp (2) with blade lock screws (5).
 - Adjust the blade height before tightening the blade lock screws (5) completely. Use a wood block to push down the blade gently until the blade edge is slightly below the straightedge (See Figure 11).
 - Check and adjust blade height at both ends of the blade.
 - Tighten the blade lock screws (5).
 - Recheck the blade height one more time. Adjust the jack screws (6) on the cutterhead if necessary.
- ### ADJUST THE HEIGHT OF THE CUTTERHEAD BLADES.
- Repeat the same procedure to replace the other blade.
 - Return the blade guard (4) to its original position.

- Never mix new blade with old blade on the cutterhead. Never mix blades with different degrees of wear. Never use a blade where unbalanced wear from side to side is present. Never use a blade that has been reground to less than 13/16" wide.

SHARPENING BLADES

- The blades can be sharpened with a fine sharpening stone.
- Protect the table top so the sharpening stone would not scratch the table surface.
- Adjust the infeed table so the sharpening stone can reach beveled edge of the blade.
- Gently grind the stone against the blade edge from side to side until the blade is sharp again.
- Repeat the same procedure on each blade.
- If the blades can not be sharpened this way, they need to be replaced or removed and reground. If a blade becomes less than 13/16" wide after several grindings, it has to be replaced.
- Never mix new blade with old blade on the cutterhead. Never mix blades with different degrees of wear. Never use a blade where unbalanced wear from side to side is present. Never use a blade that has been reground to less than 13/16" wide.

REPLACE THE FAN BELT

WARNING

Turn the switch in the "OFF" position and disconnect the jointer from the power source.

- In a clean and well-lit workplace, lay the machine on the ground. The switch panel is now facing up.
- Unscrew and remove the bottom cover (Key No. 113).
- Unscrew and remove the pulley cover (Key No. 102).
- Replace with only new fan belt (Key No. 80). Replace the new fan belt over fan and drive pulleys (Key No. 79 and 81). Check that the fan belt sits securely in the grooves of pulleys on both ends.
- Replace the pulley cover (Key No. 102), secure with screws.
- Replace the bottom cover (Key No. 113), secure with screws.

REPLACE THE DRIVE BELT

WARNING

Turn the switch to the "OFF" position and disconnect the jointer from the power source.

- In a clean and well-lit workplace, lay the machine on the ground. The switch panel is now facing up.
- Unscrew and remove the bottom cover (Key No. 113).
- Unscrew and remove the pulley cover (Key No. 102).
- Locate the fan belt (Key No. 80) and remove it. Gently pull the fan belt (Key No. 80) away from the pulleys (Key No. 79 and 81) while slowly turning the belt on the drive pulley (Key No. 81). Let the belt roll off the pulleys (Key No. 79 and 81).
- Remove the drive belt (Key No. 101) from the pulleys (Key No. 81 and 109).
- Replace with only new drive belt. Place the new drive belt onto the pulley groove on both ends.
- Replace the fan belt (Key No. 80) over fan and drive pulleys (Key No. 79 and 81). Check that the fan belt sits securely in the grooves of pulleys on both ends.
- Replace the pulley cover (Key No. 102), secure with screws.
- Replace the bottom cover (Key No. 113), secure with screws.

INSPECT AND REPLACE MOTOR BRUSHES

WARNING

Turn the switch in the "OFF" position and disconnect the jointer from the power source.

- Inspect the motor brushes after every 100 hours of use. Brush life varies, depending on the motor loads.
- Replace the motor brushes in set (Two brush assemblies) only. Replace with new parts only.
- To inspect motor brushes, unscrew brush caps on the sides of motor. There are two caps, one on each side of motor.
- Remove brush assembly from motor.
- Replace motor brushes if the length of carbon has been worn to less than 3/8", or if the springs are worn, or if the motor does not run smoothly.
- Replace with new motor brush assembly. Replace the brush cap and tighten the screw.
- Repeat the same procedure on the other side of motor.

GENERAL MAINTENANCE AND LUBRICATION

- Keep the jointer in good ^{condition} conditions. Vacuum excess wood chips and sawdust after each use. Wipe off the remaining dust away with a dry cloth.
- Apply a thin coat of paste type wax to the tables and the fence to prevent corrosion and help moving work piece smoothly during operation.
- Keep blades sharp. Blades should be sharpened or replaced in set of two.
- Motor and cutterhead bearing are permanently sealed in factory, they should required no further lubrication.

KEEP TOOL IN REPAIR

- If power cord is worn, cut or damaged in any way, do not operate the machine.
- Replace any worn, damaged, or missing parts. Use parts listed to order parts.
- Any attempt to repair motor may create a hazard unless repair is done by a qualified service technician.
- Call the customer line at 1-877-393-7121.

SYMPTOM	POSSIBLE CAUSE(S)	CORRECTIVE ACTION
Motor will not start	<ol style="list-style-type: none"> 1. Low voltage 2. Short circuit in line cord or plug 3. Short circuit in motor 4. Open circuit or loose connection in motor 5. Incorrect fuses or circuit breakers 6. Defective switch 7. Defective capacitor 	<ol style="list-style-type: none"> 1. Check power supply for proper voltage 2. Inspect line cord and plug for faulty insulation or shorted connection 3. Inspect connection on motor. 4. Inspect connection on motor 5. Replace with correct fuses or circuit breakers 6. Replace switch 7. Replace capacitor
Motor stalls or fails to reach full speed	<ol style="list-style-type: none"> 1. Power overload 2. Low voltage from power supply 3. Undersized line cord 4. Motor overload 5. Short circuit or loose connection in motor 6. Incorrect fuses or circuit breakers 7. Wood chips clogged 	<ol style="list-style-type: none"> 1. Reduce workload on the power supply 2. Check power supply for proper voltage 3. Use line cord of adequate size or reduce length of wiring 4. Reduce load on motor 5. Inspect the connection in motor for loose or shorted connection 6. Replace with correct fuses or circuit breakers 7. Inspect chip blower assembly and fan belt. Remove excessive wood chips
Motor overheats	<ol style="list-style-type: none"> 1. Motor overloaded 2. Excessive dust build-up results in decreased air circulation 	<ol style="list-style-type: none"> 1. Reduce load on motor. Turn off the machine until motor cools down 2. Remove dust build-up
Frequent tripping of circuit breaker	<ol style="list-style-type: none"> 1. Motor overload 2. Inadequate capacity of circuit breaker 3. Circuit overload 4. Blades are dull 	<ol style="list-style-type: none"> 1. Reduce load on motor 2. Replace with correct circuit breaker 3. Reduce circuit load 4. Sharpen or replace blades
Snipe	<ol style="list-style-type: none"> 1. Inadequate support of workpiece 2. Feed workpiece unevenly 3. Blades are dull 	<ol style="list-style-type: none"> 1. Support long workpiece with additional platform 2. Feed workpiece evenly 3. Sharpen or replace blades
Uneven cut	<ol style="list-style-type: none"> 1. Feed workpiece too fast 2. Fence is not perpendicular to jointer bed 3. Blades height is not uniform 	<ol style="list-style-type: none"> 1. Feed workpiece slowly 2. Adjust fence and fence bracket properly 3. Adjust blade height properly
Inaccurate cut angle	<ol style="list-style-type: none"> 1. Wood chips under bottom of fence 2. Fence and fence bracket are not adjusted properly 	<ol style="list-style-type: none"> 1. Clean wood chips under the bottom of fence 2. Adjust fence and fence bracket properly
Surface not smooth	<ol style="list-style-type: none"> 1. Blades are dull 2. Fuzzy grain due to high moisture content in wood 3. Torn grain due to blades cutting against grain 4. The cut is too deep 	<ol style="list-style-type: none"> 1. Sharpen or replace blades 2. Use dry wood 3. Change direction and feed workpiece along grain 4. Decrease depth of cut



6" BENCH JOINTER PARTS LIST

Key No.	Part No.	Part Name	Qty	Key No.	Part No.	Part Name	Qty
1	BJ600001	6 MM HEX NUT	4	61	BJ600061	DUST COLLECTION WIRE	1
2	BJ600002	BLOCK	1	62	BJ600062	DUST CHUTE	1
3	BJ600003	SHAFT	1	63	BJ600063	6x20MM PAN HEAD SCREW	1
4	BJ600004	FENCE BRACKET	1	64	BJ600064	5x12MM SOCKET HEAD BOLT	1
5	BJ600005	LIMIT PLATE	1	65	BJ600065	WASHER 5MM	1
6	BJ600006	6 X 50MM SOCKET HEAD BOLT	1	66	BJ600066	CHIP COLLECTOR	1
7	BJ600007	BRACKET SHAFT	1	67	BJ600067	SPONGE	1
8	BJ600008	6MM LOCK WASHER	14	68	BJ600068	CHIP EXHAUST	1
9	BJ600009	6 x20MM SOCKET HEAD BOLT	4	69	BJ600069	5MM FLAT WASHER	3
10	BJ600010	5 MM HEX NUT	2	70	BJ600070	IMPELLER	1
11	BJ600011	5 x25MM HEX HEAD BOLT	2	71	BJ600071	26 EEX RET RING	1
12	BJ600012	LEFT LINK	1	72	BJ600072	CHIP BLOWER MOUNTING PLATE	1
13	BJ600013	RIGHT LINK	1	73	BJ600073	ST4.2x9.5 THREAD FORMING SCREW	6
14	BJ600014	10MM PUSH NUT	2	74	BJ600074	6 x12MM SOCKET HEAD BOLT	5
15	BJ600015	FLAT WASHER 8MM	2	75	BJ600075	FAN SHAFT	1
16	BJ600016	TILTING HANDLE	1	76	BJ600076	6000ZZ BALL BEARING	2
17	BJ600017	SLIDING HANDLE	1	77	BJ600077	SPACER	1
18	BJ600018	PLATE SHAFT	1	78	BJ600078	6x8MM SET SCREW	5
19	BJ600019	8 x16MM SOCKET HEAD BOLT	4	79	BJ600079	FAN PULLEY	1
20	BJ600020	8MM LOCK WASHER	6	80	BJ600080	FAN BELT	1
21	BJ600021	FENCE PLATE	1	81	BJ600081	DRIVE PULLEY	1
22	BJ600022	8 x20MM SOCKET HEAD BOLT	2	82	BJ600082	JACK SCREW	4
23	BJ600023	FENCE SUPPORT	1	83	BJ600083	CUTTERHEAD	1
24	BJ600024	FENCE	1	84	BJ600084	BLADE	2
25	BJ600025	TABLE PIN	4	85	BJ600085	BLADE GIB	2
26	BJ600026	FRAME PIN	4	86	BJ600086	BUTTON HD CAP SCR M6-1*16	8
27	BJ600027	BRACKET	4	87	BJ600087	SHAFT	1
28	BJ600028	INFEED TABLE	1	88	BJ600088	4 x10MM PAN HEAD SCREW	1
29	BJ600029	6x30MM SET SCREW	1	89	BJ600089	PIN	1
30	BJ600030	PIN	2	90	BJ600090	SPRING	1
31	BJ600031	LOCKING PLATE	1	91	BJ600091	BASE	1
32	BJ600032	8-1.25MM HEX NUT	1	92	BJ600092	BOX FIXUPED BOARD	1
33	BJ600033	8-1.25x35MM HEX HEAD BOLT	1	93	BJ600093	RUBBER FEET	2
34	BJ600034	E-CLIP 6MM	4	94	BJ600094	6MM FLAT WASHER	16
35	BJ600035	TABLE FRAME	1	95	BJ600095	6x8MM SOCKET HEAD BOLT	16
36	BJ600036	6 x35MM SET SCREW	1	96	BJ600096	RUBBER FEET	2
37	BJ600037	SUPPORT PLATE	1	97	BJ600097	SWITCH	1
38	BJ600038	5MM LOCK WASHER	6	98	BJ600098	RUBBER BUMPER	1
39	BJ600039	5x10MM SOCKET HEAD BOLT	7	99	BJ600099	BLADE GUARD	1
40	BJ600040	KNOB SHAFT	1	100	BJ600100	SPRING	1
41	BJ600041	KNOB	1	101	BJ600101	DRIVE BELT	1
42	BJ600042	FLAT WASHER 5MM	2	102	BJ600102	PULLEY COVER	1
43	BJ600043	5 x10MM PAN HEAD SCREW	4	103	BJ600103	5 x6MM PAN HEAD SCREW	2
44	BJ600044	TABLE	1	104	BJ600104	6 x14MM SOCKET HEAD BOLT	1
45	BJ600045	SPONGE	1	105	BJ600105	CORD CLAMP	1
46	BJ600046	PLATE	1	106	BJ600106	6MM FLAT WASHER	1
47	BJ600047	5 x8MM PAN HEAD SCREW	4	107	BJ600107	WIRE PRESS BUCKLE UC-1.5	1
48	BJ600048	12 RETAINING RING	1	108	BJ600108	MOTOR MOUNTING PLATE	1
49	BJ600049	6201ZZ BALL BEARING	2	109	BJ600109	MOTOR PULLEY	1
50	BJ600050	LINE CORD	1	110	BJ600110	MOTOR	1
51	BJ600051	5MM SERRATED WASHER	2	111	BJ600111	SPADE TERMINAL	2
52	BJ600052	5 x10MM PAN HEAD SCREW	2	112	BJ600112	NYLON TIE	2
53	BJ600053	6N3-4 STRAIN RELIEF	1	113	BJ600113	COVER	1
54	BJ600054	6 x16MM SET SCREW	4	114	BJ600114	5 x8MM PAN HEAD SCREW	4
55	BJ600055	6MM FLAT WASHER	10	115	BJ600115	PUSH BLOCK	2
56	BJ600056	6- 30MM SOCKET HEAD BOLT	4	116	BJ600116	HEX NUT M6	1
57	BJ600057	OPERATOR'S MANUL	1	117	BJ600117	BAG CLAMP	1
58	BJ600058	6MM WRENCH	1	118	BJ600118	PIN	1
59	BJ600059	4MM WRENCH	1	119	BJ600119V	CLAMP HANDLE	1
60	BJ600060	DUST COLLECTION BAG	1	120	BJ600120	PIVOT BOLT 6x40	1

Thank you for investing in a **POWERTEC** power tool. These products have been designed and manufactured to meet high quality standards and are guaranteed for domestic use against defects in workmanship or material for a period of 12 months from the date of purchase. This guarantee does not affect your statutory rights.

SOUTHERN TECHNOLOGIES LLC. BENCH TOP AND STATIONARY POWER TOOL LIMITED 1 YEAR WARRANTY AND 30-DAY SATISFACTION GUARANTEE POLICY

POWERTEC products are designed and manufactured by **Southern Technologies LLC**. All warranty communications should be directed to **Southern Technologies LLC**, 206 Terrace Dr. Mundelein, IL 60060, Attn: **POWERTEC** technical service ; or by calling 1-877-393-7121 (toll free), 9 AM to 5 PM, Monday through Friday, US Central Time.

30- DAY SATISFACTION GUARANTEE POLICY

During the first 30 days after the date of purchase, if you are dissatisfied with the performance of this **POWERTEC** tool for any reason (add comma) you may return the tool to the retailer from which it was purchased for a full refund or exchange. You must present proof of purchase and return all original equipment packaged with the original product. The replacement tool will be covered by the limited warranty for the balance of the one year warranty period.

LIMITED ONE YEAR WARRANTY

This warranty covers all defects in workmanship or materials in this **POWERTEC** tool for a one year period from the date of purchase. This warranty is specific to this tool. **Southern Technologies, LLC** reserves the right to repair or replace the defective tool, at its discretion.

HOW TO OBTAIN SERVICE

To obtain service for this **POWERTEC** tool you must return it, freight prepaid, to an authorized **POWERTEC** service center for bench top and stationary power tools. You may obtain the location of the authorized service center nearest you by calling (toll free) 1-877-393-7121 or by logging on to the **POWERTEC** website at www.southerntechllc.com. When requesting warranty service, you must present the proof of purchase documentation, which includes a date of purchase. The authorized service center will either repair or replace any defective part, at our option at no charge to you. The repaired or replacement unit will be covered by the same limited warranty for the balance of one year warranty period.

WHAT IS NOT COVERED

This warranty applied to the original purchaser at retailer and may not be transferred.

This warranty does not cover consumable items such as saw blades, knives, belts, discs, cooling blocks and sleeves.

This warranty does not cover required service and part replacement resulting from normal wear and tear, including accessory wear.

This warranty does not cover any malfunction, failure or defect resulting from:

- 1) misuse, abuse, neglect and mishandling not in accordance with the owner's manual.
- 2) damage due to accidents, natural disasters, power outage, or power overload (add period)
- 3) commercial or rental use (add period)
- 4) alteration, modification or repair by other than an authorized service center for **POWERTEC** product.

DISCLAIMER

To the extent permitted by applicable law, all implied warranties, including warranties of MERCHANTABILITY or FITNESS FOR A PARTICULAR PURPOSE, are disclaimed. Any implied warranties, that cannot be disclaimed under state law are limited to one year from the date of purchase. **Southern Technologies LLC.** is not responsible for direct, indirect, incidental or consequential damages. Some states do not allow limitations on how long an implied warranty lasts and/or do not allow the exclusion or limitation of incidental or consequential damages, so the above limitations may not apply to you. This warranty gives you specific legal rights, and you may also have other rights which vary from state to state. Southern Technologies LLC., makes no warranties, representations, or promises as to the quality or performance of its power tools other than those specifically stated in this warranty.

**NOTE**

A large, empty rectangular box with rounded corners, intended for additional notes or information.

POWERTEC PRO

Southern Technologies, LLC
206 Terrace Drive
Mundelein, Illinois 60060