



Gourmia

MODEL# GVS445

**VACUUM SEALER
FOOD PRESERVER**

Gourmia

www.gourmia.com





Welcome to **Benefits** of Food Storage from Gourmia!

With the purchase of your Vacuum Sealer, you are ready to enjoy the benefits and money saving rewards of keeping food fresh longer! Gourmia has created the perfect solution to the unwanted waste that results from conventional food storage – with the GVS445 Vacuum Sealer! By removing air from the storage bags, the freshness of food is greatly extended. Keep food fresher and longer in your pantry, freezer or refrigerator. With all the delicious foods you can preserve, the Vacuum Sealer is sure to become your favorite kitchen appliance.

The following pages of this manual offer full and complete instructions for all the functions and features of your Vacuum Sealer. Inside these pages, you'll find information on and instructions for assembly, operating, cleaning and maintenance of your Vacuum Sealer. Please read all safety instructions and complete directions carefully for safe usage at all times.

Thank you for your purchase! We hope you will enjoy all the innovative products brought to you by our family at Gourmia.

© 2016 Gourmia

www.Gourmia.com

The Steelstone Group

Brooklyn, NY

All rights reserved. No portion of this manual may be reproduced by any means whatsoever without written permission from The Steelstone Group, except for the inclusion of quotations in a media review.

Although every precaution has been taken in the preparation of this manual, The Steelstone Group assumes no responsibility for errors or omissions. Nor is any liability assumed for damages resulting from the use of the information contained herein. Although every effort has been made to ensure that the information contained in this manual is complete and accurate, The Steelstone Group is not engaged in rendering professional advice or services to the individual consumer; further, The Steelstone Group shall not be held responsible for any loss or damage allegedly arising from any information or suggestion in this manual.

10 9 8 7 6 5 4 3 2 1

Printed in China

SAFETY FIRST p. 6

FEATURES & FUNCTIONS p. 8

OPERATING INSTRUCTIONS p. 12

HELPFUL HINTS & STORAGE GUIDELINES p. 16

CLEANING & MAINTENANCE p. 19

TROUBLESHOOTING / WARRANTY & SERVICE p. 20

PRODUCT SPECS & NOTES p. 23



IMPORTANT SAFEGUARDS

When operating this electric appliance, basic safety instructions should always be followed. Refer to the following for these instructions

1. READ ALL SAFETY & USAGE INSTRUCTIONS BEFORE USING.
2. Do not use appliance on wet or hot surfaces, or near a heat source.
3. To protect against electric shock, do not immerse any part of appliance, power cord or plug in water or other liquid. Unplug from outlet when not in use and before cleaning.
4. To disconnect, unplug power cord from electrical outlet. Do not disconnect by pulling on cord.
5. Do not operate appliance with a damaged power cord or plug. Do not operate appliance if it malfunctions or is in any way damaged. For details, contact Consumer Services.
6. Use appliance only for its intended use.
7. Closely supervise children when using any electrical appliance. Do not allow appliance to be used as a toy.
8. The appliance has a polarized plug (one blade is wider than the other). To reduce risk of electrical shock, this plug is intended to fit in a polarized outlet only one way. If plug does not fit fully in the outlet, reverse plug. If it still does not fit, contact a qualified electrician. Do not modify plug in any way.
9. Caution: A short power cord is provided to reduce risks from entanglement or tripping over a longer cord. An extension cord may be used when marked electrical rating is no less than electrical rating of this appliance. All cords should not drape over counter or tabletop where cords can be tripped over or pulled on unintentionally, especially by children.
10. Do not place on or near a hot gas or electric burner, or heated oven. Extreme caution must be used when moving products containing hot liquids.
11. Wait at least 20 seconds between seals to allow appliance to cool.
12. For Household Use Only.

SAVE THESE INSTRUCTIONS

FOR HOUSEHOLD USE ONLY



Electrical 3-conductor Cord Set:

Appliance is equipped with a 3-conductor cord set that has a 3 prong grounding-type plug. It should be properly connected to a grounding-type outlet. The plug is designed to fit ONLY a 3-grounding outlet unit, and as such, the grounding prong should never be removed. If needed, purchase a 2-prong adapter and ground it to the outlet. Consult a qualified electrician if in doubt. Do not use an adapter unless you are confident it is grounded. Do not modify this plug. If the plug does not fit the outlet securely, call a qualified electrician for assistance.

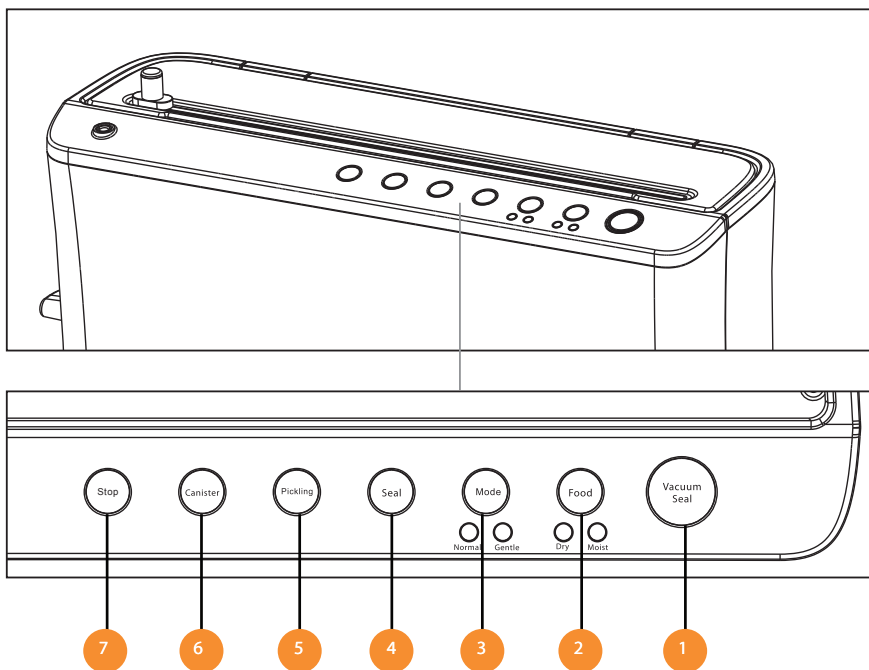

FEATURES & FUNCTIONS

1. Vacuum Seal button: Press this button to vacuum and seal bag (intervals of 40 seconds is recommended before repeating.)
2. Food button has two settings (Dry and Moist). The default mode is Dry, when you press the button, it changes to Moist mode. You can choose the mode according to the food type.
3. Mode button has two settings (Normal and Gentle). The default mode is Normal. When vacuum sealing food that is delicate or easily crushed, you can press this button, and the vacuum mode switches to Gentle. You can manually control the amount of vacuum by pressing the Seal button at any time, the bag will seal automatically. (Note: if the power is interrupted, the setting will revert to standard mode).
4. Seal button (with LED) begins sealing bag (intervals of 40 seconds is recommended before repeating.)
5. Pickling button (with LED) marinates the food by concentrating liquids. You get great flavor in the shortest amount of time. (Note: This function is used with the canister/container).
6. Canister button (with LED) is the button to press to begin the vacuum packaging using the canister. (Note: This function can only be used with compatible canisters).
7. Stop button allows you to stop processes at anytime.

- A. Cutter button cuts the bag to any length you want.
- B. Roll Lid holds the bag roll inside the chamber.
- C. Latches, one on each side, are pressed down at same time, a click sound indicates the hooks are locked correctly.
- D. Release Buttons, one on each side, are pressed down at same time to open unlock.
- E. Air vacuum opening is used when you vacuum package using canisters or other accessories. One end of the hose fits into this opening. Do not ever block this hole.
- F. Drawer pulls out for easy cleaning and component exchange.
- G. Liquids Box is used when air is vacuumed out, liquids will be suctioned out and flow into the Liquids Box. Please clean this box after each use.
- H. Rubber Lip
- I. Gasket

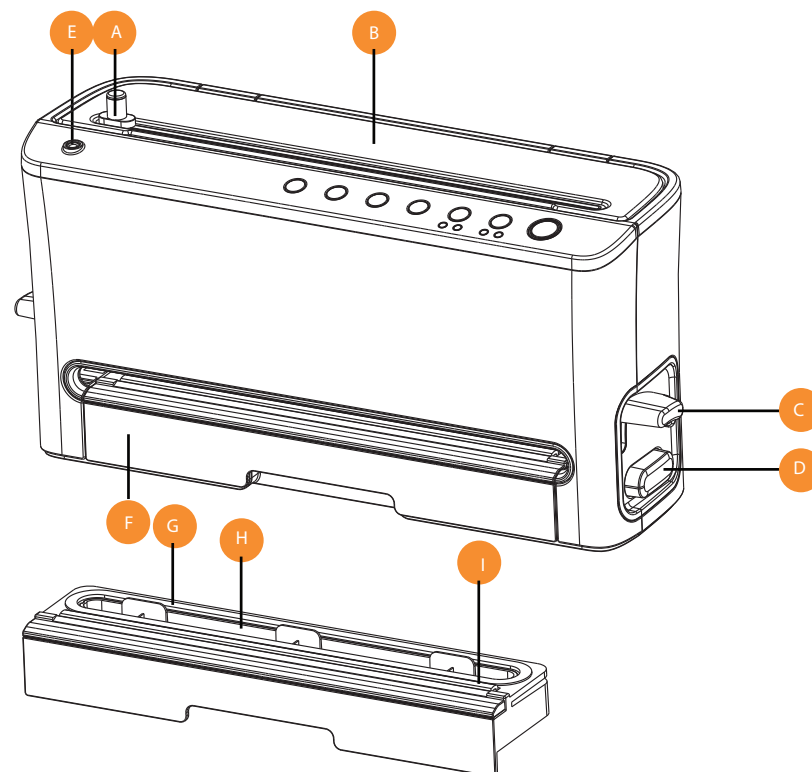

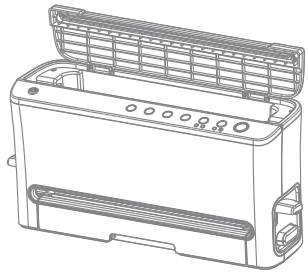

FIG. 1

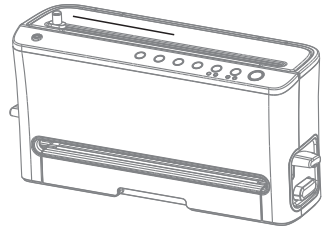

FIG. 2

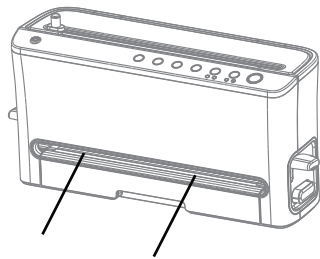

FIG. 3

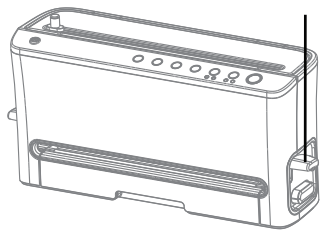

FIG. 4

VACUUM BAGS FROM ROLL

- 1 Open the Roll Lid, pull out the desired length of bag. **FIG. 1**
- 2 Close the Roll Lid. Push the Cutter from left to right to choose the length of the bag you need. (Note: You do not need the cutter if you are using a vacuum bag.) **FIG. 2**
- 3 Insert the opening of the bag into the vacuum chamber evenly. **FIG 3**
- 4 Insert about 3cm in, then press down on the latches on both sides until it clicks into to the position, the bag is now ready for vacuum sealing process. **FIG. 4**

SEAL VACUUM BAGS AND VACUUM CANISTER

SEAL PLASTIC BAGS

- 1 Plug the appliance in and switch it on.
- 2 Insert the open end of the bag into the vacuum chamber.
- 3 Press down the latches on both sides at the same time until two clicking sounds are heard.
- 4 Press the Seal button until the LED light comes on. When the LED light turns off, the seal is complete.
- 5 Press the Release button to open and take out the sealed bag.

PACKING WITH VACUUM BAG

- 1 Plug in the appliance and switch it on.
- 2 Put the items inside the bag.
- 3 Clean and straighten the open side of the bag, make sure there are no wrinkles, moisture or dust on the edge.
- 4 Insert the open end of the bag into the vacuum chamber.
- 5 Press down the 2 latches on the sides at the same time until two click sounds are heard.
- 6 Press the Vacuum Seal button until the LED turns on, the vacuum and seal process will begin automatically. When the LED light turns off, the process is complete.
- 7 Press the Release buttons on the two sides, then take out the sealed items.

Note: If the food is wet, please choose the Moist mode.

PACKING WITH VACUUM CANISTERS

- 1 Put the items inside the canister and cover it with the lid. Insert one end of the hose into the Vacuum Air Hole, and insert the other end into the hole on top of the canister lid.
- 2 Press the Canister button and it will begin to draw the air from the canister and create a tight seal. You can press the Stop button to cancel at anytime. When the vacuum process is completed, the appliance will automatically stop.
- 3 Pull one end of the hose from the canister first, then pull the other end from the appliance.
- 4 When the stored items are expired or need to be removed from the canister, simply press down on the button in the center of the canister lid to release the seal, then open the canister after a few seconds.

TIPS ON USING CANISTER

Please remove the lid before you putting the canister in a microwave oven.
Place the canister in refrigerator for longer freshness time.

HELPFUL HINTS

1. Do not overfull the bags, leave enough length at the opening of the bag so that it can be placed in the vacuum chamber easily. Make sure to leave at least 2.5cm (1 inch) space between objects and top of bag.
2. Ensure that the opening the bag is not wet. A wet bag may be difficult to melt and seal tightly.
3. Vacuum sealing cannot completely replace refrigeration and freezing. Perishable foods still need to be refrigerated or frozen.
4. Make sure the opening of plastic bag is clean and flat, otherwise it will cause leakage during the seal.
5. To prevent wrinkles in a seal when vacuum sealing bulky items, gently stretch bag flat while inserting into the vacuum chamber and hold it until the pump starts up.
6. When you are vacuum sealing items with sharp edges (dry spaghetti, silverware etc.), protect the bag from punctures by wrapping item in soft cushioning material, such as tissue paper, you may need to use a canister or container instead of a bag.
7. When using accessories, remember to leave 2.5cm (1 inch) of space at top of canister or container.
8. Pre-freeze fruits and blanch vegetables before vacuum sealing for the best results.
9. Cool down intervals of 40 seconds after seal or vacuum is recommended.
10. If you are unsure whether the bag is sealed properly, repeat reseal process.
11. For best results, please use quality bags, canisters, containers and accessories.
14. Wipe the edge of the jar, container or bottle to make sure it is clean and dry.

FOOD STORAGE GUIDELINES

CLASSIFICATION	FOOD ITEMS	TEMP.	NORMAL STORAGE	VACUUM STORAGE
REFRIGERATED	Fresh Raw Meat	5±3°C	2-3 days	8-9 days
	Fresh Fish/ Sea Food	5±3°C	1-3 days	4-5 days
	Cooked Meat	5±3°C	4-6 days	10-14 days
	Vegetables	5±3°C	3-5 days	7-10 days
	Fruit	5±3°C	5-7 days	14-20 days
	Eggs	5±3°C	10-15 days	30-50 days
FROZEN	Meat	-16~ - 20°C	3-5 months	>1 year
	Fish	-16~ - 20°C	3-5 months	>1 year
	Sea Food	-16~ - 20°C	3-5 months	>1 year
ROOM TEMPERATURE	Bread	25±2°C	1-2 days	8-10 days
	Biscuit	25±2°C	4-6 months	>1 year
	Rice/ Flour	25±2°C	3-5 months	>1 year
	Peanut/Legume	25±2°C	3-6 months	>1 year
	Medical Material	25±2°C	3-6 months	>1 year
	Tea	25±2°C	5-6 months	>1 year

CLEANING THE VACUUM SEALER

1. Always unplug the unit before cleaning.
2. Don't immerse the appliance in water or other liquid for cleaning.
3. Do not use abrasive cleaners to clean, because it is easy to scratch the surface of the appliance.
4. Wipe the outside of the appliance with a damp cloth or sponge with mild soap if necessary.
5. To clean the vacuum chamber, wipe away any food or liquid.
6. Dry thoroughly before using again.
7. Clean the Drawer. Be sure to pull out the drawer smoothly. **FIG. 1**
Then take out the Liquid Box and clean it. **FIG. 2**

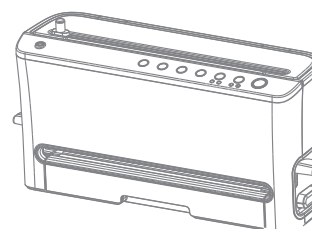

FIG. 1

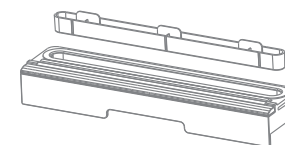

FIG. 2

IMPORTANT: To avoid possible illness, do not reuse bags after storing raw meats, raw fish or greasy foods. Do not reuse bags that have been microwaved or boiled.

Storing Your Vacuum Sealer:

Keep the unit in a flat and safe place, out of the reach of children. Damage or distortion can cause leakage.

TROUBLE SHOOTING

In the unlikely event that you experience a problem with your device, please take a couple of minutes to check these possible causes prior to contacting customer support:

PROBLEM	POSSIBLE CAUSE	SOLUTION
Vacuuming but Is not sealing automatically	Lower gasket is deformed	Replace it and try again
	Edge of bag is covering the suction hole	Place the bag in the correct position
	Bag is overfilled and may be preventing the cover from locking	Take out some food and clean the bag edges, try again
	The bag is broken or leaking	Use a new bag and try again
Sealing OK but not vacuuming	The bag is not placed correctly in the vacuum chamber	Place the edge of the bag into the vacuum chamber
	The bag is covering suction hole	Place the bags in the correct position
	The edge of the bag has dirt, dust or crumbs	Clean the edge of bag and try again
	Edge of bag has wrinkles	Smooth the bag and try again
	Contents have sharp edges	Use the food safety paper pack before putting into the vacuum bag
Bag is inflating/ expanding after vacuum sealing	The food is highly corrosive	Freeze or refrigerate after vacuuming to prolong it's shelf life
	The food packed is fresh vegetables, fruit or seeds	They are not suited to storage at room temperature. They have photosynthesis and respiration. Keep refrigerated

WARRANTY & SERVICE

This Limited Warranty is for one full year from the date of purchase. It is applicable to the original purchaser only and is not transferable to a third party user. Repair or replacement of defective parts is solely at the seller's discretion. In the event that repair isn't possible, the seller will replace the product/part. If product repair/replacement won't suffice, the seller has the option of refunding the cash value of the product or component returned.

Product defects not covered under the Warranty provisions include normal wear and damage incurred from use or accidental negligence, misuse of instruction specifications or repair by unauthorized parties. The manufacturing company is not liable for any incidental or consequential damages incurred by such circumstances.

For Customer Service or Questions, Please call: 888-552-0033

Gourmia
www.gourmia.com

DISPOSAL OF THE DEVICE
PROTECTION OF THE ENVIRONMENT 
At the end of the life of your product, it should go to a specially adapted waste-recycling center.

ENVIRONMENT PROTECTION FIRST



1. The symbol  on the product or on its packaging indicates that this product may not be treated as household waste. Instead it should be handed over to the applicable. Collection point for the recycling of electrical and electronic equipment.
2. By ensuring this product is disposed of correctly, you will help prevent potential negative consequences for the environment and human health, which could otherwise be caused by inappropriate waste handling of this product. For more detailed information about the recycling of this product, Please contact your local council office or your household waste disposal service.

PRODUCT SPECS

Product Size	410 x 130 x 203mm
Vacuum bsg roll	Gourmia vacuum bag/roll(max width 30cm)
Voltage	110V-120V AC 50-60Hz
Power	110 W
Seal Way	Heat wire heating
Vacuum Degree	0.8 bar MAX
Mode	Normal/Gentle
Food	Dry/Moist
Canister	Available
Net Weight	2.73 kg
Package Size	490 x 160 x 265mm

NOTES:
