

Full / Queen  
**Smart BoxSpring®**  
**Instruction**

**Components** ▾

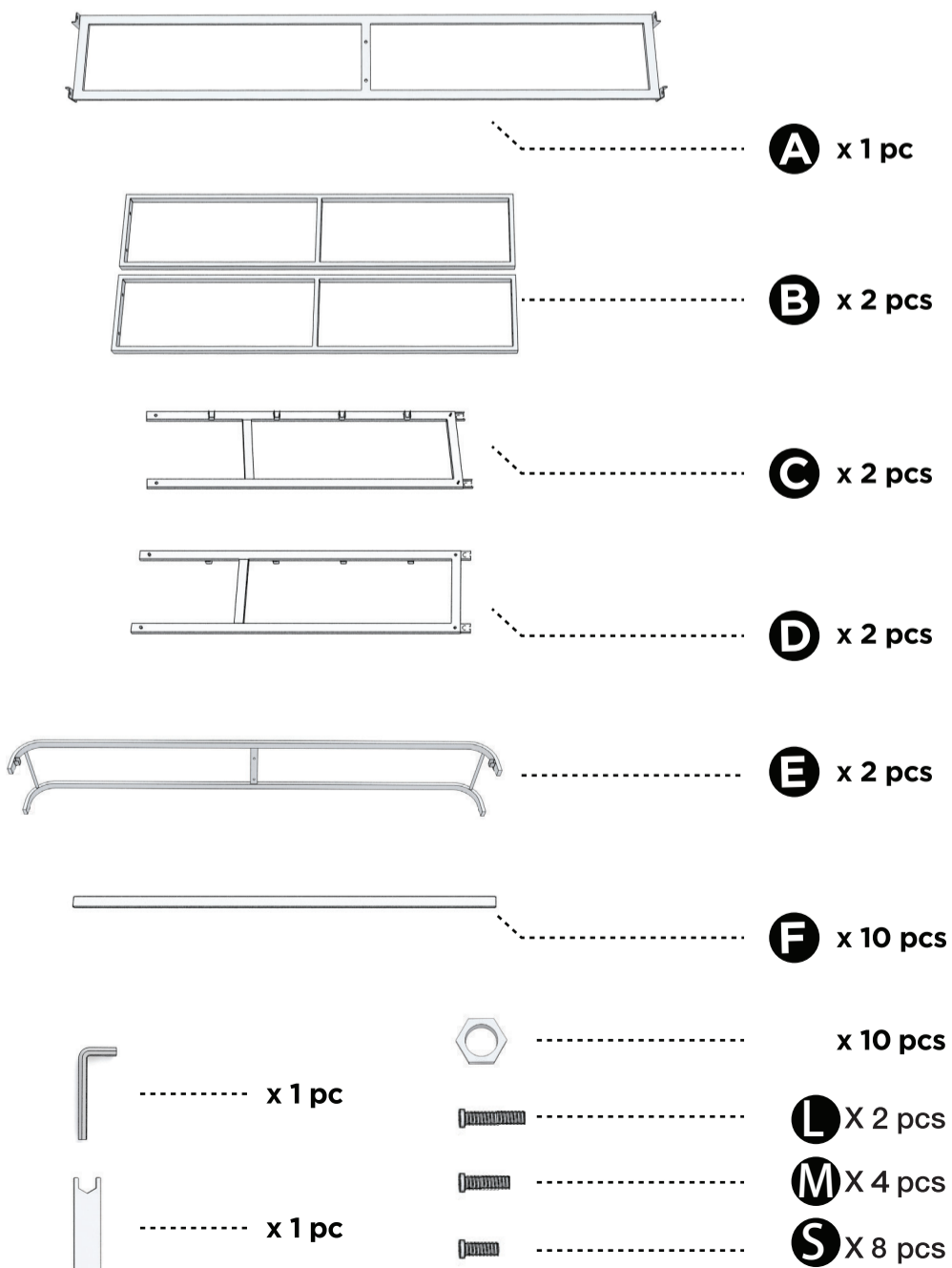

**Return Policy** ▾

ZINUS believes you will absolutely love your Smart BoxSpring®, but if for some reason you want to return your Frame please call us directly before you decide to return your product to the retailer. Our Customer Service organization can answer most concerns and can assist you with any questions you may have about your Smart BoxSpring®. Please call us first at: 1-800-613-1225.

The item must be returned within 30 days of delivery for a full refund. The item must be returned in good condition, in original box, with all original proof of purchase, parts and accessories.

**5-Year Limited Warranty Statement For Manufacturing Defects**

Please read this Limited Warranty carefully. To maintain your Warranty, you will need to comply with the conditions stated here. This warranty is for manufacturing defects only and does not cover damages as a result of misuse.

1. Please be sure to register your product at [www.zinus.com/resources/register](http://www.zinus.com/resources/register) to receive up to date warranty and product information.
2. Your Smart BoxSpring® comes with 5 year warranty against manufacturing defects that may compromise the sleep quality provided by the Frame. The warranty starts on the date of purchase. No warranty will be honored without an original sales receipt. The warranty and financial responsibility of the manufacturer only applies to the Frame itself and does not extend to mattresses that are used on the Frame
3. Manufacturing defects include circumstances where Frame has broken under normal use and no longer provides proper support for your mattress. Proper support is defined as a smooth, flat, rigid surface. In the event you encounter a manufacturing defect, please stop using this product immediately and call customer service.
4. This warranty applies only when the Frame has been properly used by consumers who purchased the Frame from authorized dealers as a new product. Proper use means using the foundation on a level surface with an equal distribution of weight. Proper use also means that Frame was not abused by the consumer, as defined by the manufacturer. This warranty does not constitute agreement to replace other parts.
5. If the Frame fails due to manufacturing defects, the manufacturer will repair or replace at its discretion and reserves the right to substitute comparable materials or models and does not guarantee that the replacement part will match the existing piece or foundation.
6. In the event Frame needs to be inspected by the manufacturer to determine a warranty claim, the transportation cost or removal cost is borne by the consumer.

# 1

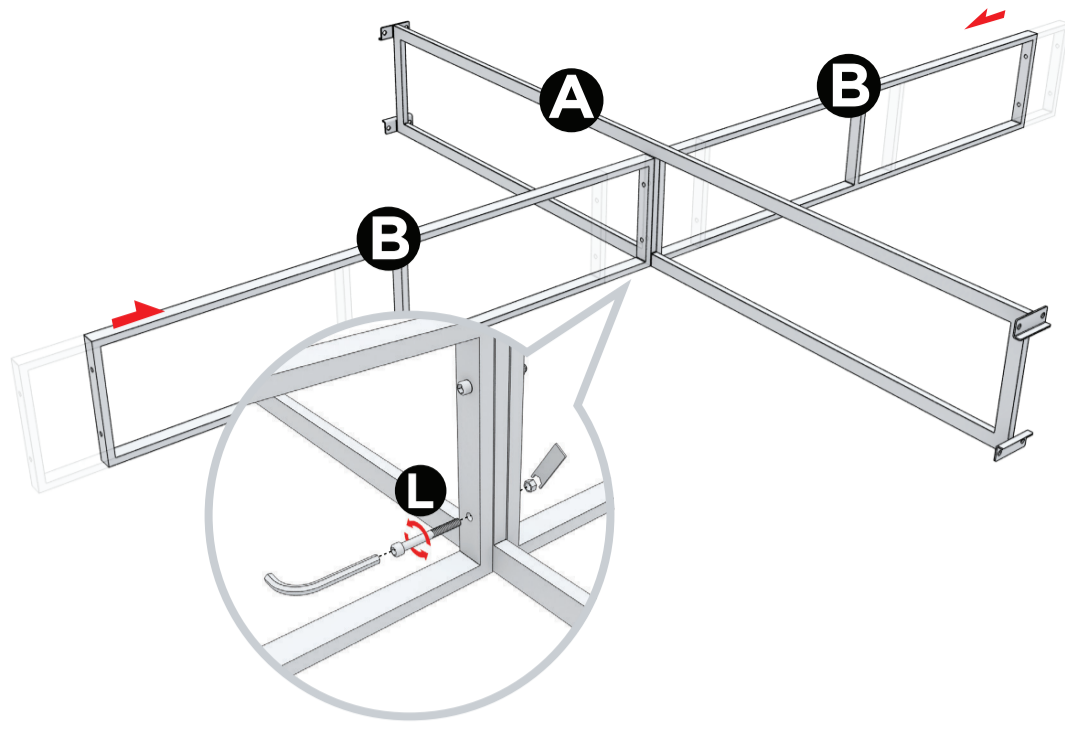

# 2

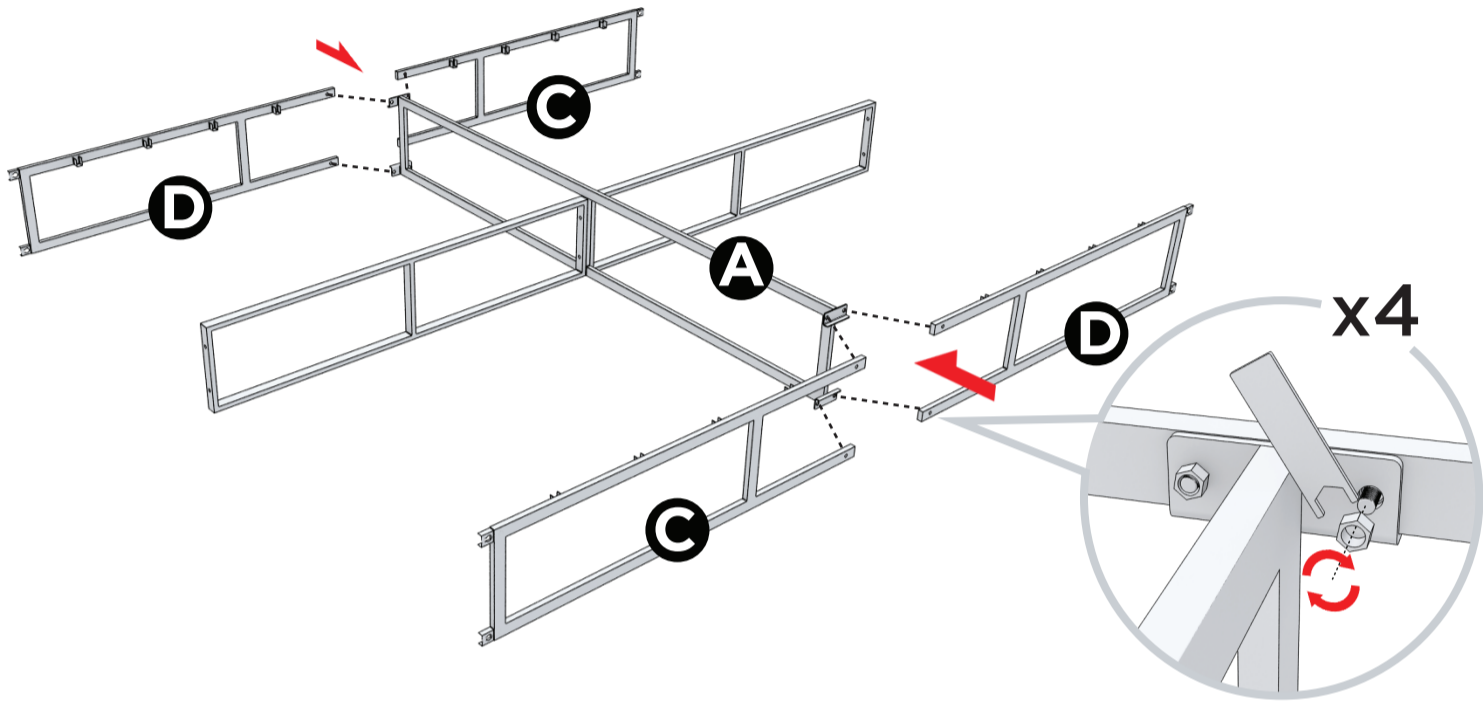

# 3

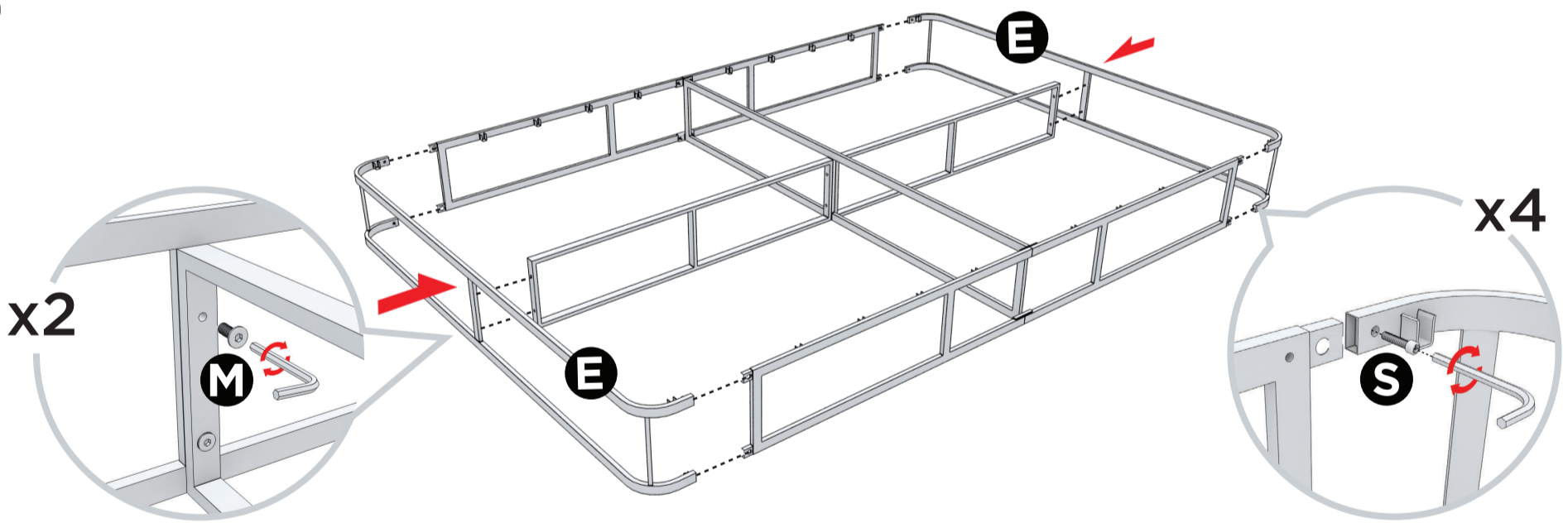

# 4

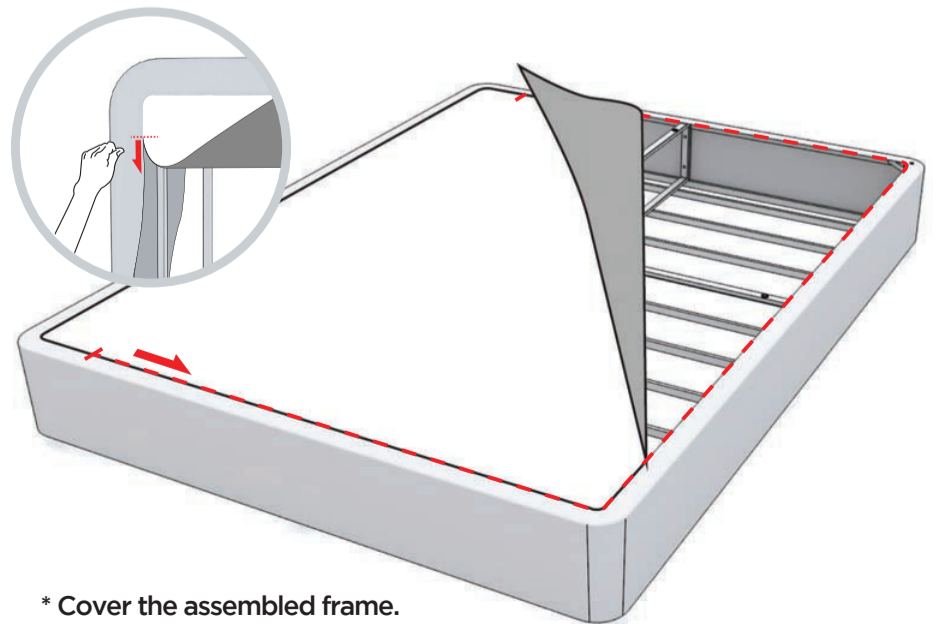
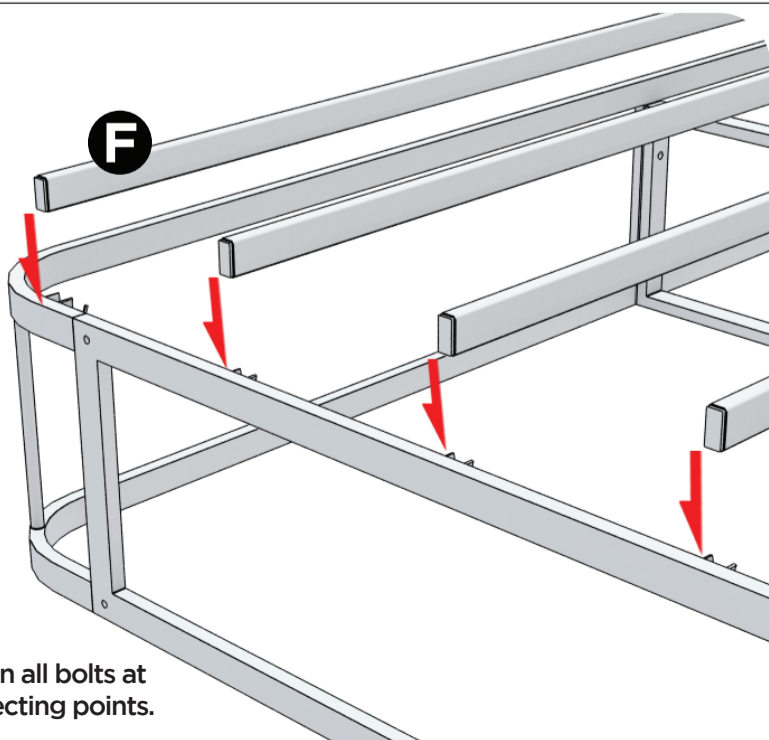

\* Fasten all bolts at connecting points.

\* Cover the assembled frame. Zip after inverting the covered frame.