

ROCKVILLE



dB
series
OWNER'S MANUAL

Introduction

Thank you for purchasing this Rockville dB Series amplifier. Over the years, the technology used to create audio amplifiers has grown by leaps and bounds. Our competition is satisfied with just continuing to build the same units year after year without thought for improvement, but not Rockville. We consider it our mission to use our expertise in developing the latest technologies and to bring you the absolute best sounding amplifiers on the market and of course at a reasonable price. You will be amazed at the quality and power that these new amps offer.

We have spared no expense in designing these amplifiers, creating the most rugged, reliable, powerful and best performing amplifiers. In fact we are so sure of the quality we backup every dB Series amplifier with one year warranty which exemplifies our commitment to the end user. (See enclosed warranty card for details.)

Please read this installation guide carefully for proper use of your dB Series amplifier. Read this entire guide fully before attempting your installation.

IMPORTANT SAFETY INSTRUCTIONS



WARNING: BE AWARE! Use of this amplifier at extreme high volumes for extended periods of time may cause hearing loss and or hearing damage. During periods of prolonged high volume levels it is recommended that you use ear safety devices. Your ability to hear necessary traffic sounds will be impaired. While driving always keep your sound volume at reasonable levels. We at Rockville want you listening for many years to come.

- When installing the amplifier, secure it tightly. An unmounted amplifier in your car can cause serious injury to passengers and damage to your vehicle if it is set in motion by an abrupt driving maneuver or short stop.
- To reduce risk of electric shock, never open the unit. There are no user serviceable parts, refer service to an authorized Rockville service center.
- Do not expose this unit to any kind of moisture.
- Please ensure that the unit is situated in a properly ventilated area.

Features

Bass Equalization Circuitry

A narrow “Q” peaking equalization circuit is included in the amplifiers. The equalization system is preset at 45Hz. The equalizer control allows you to add up to 12dB of bass boost. Utilize the bass equalizer to tailor your bass response to your systems needs. Make sure your speakers can handle the extra power output! It would be foolish to add 12dB of gain to low excursion 8” and 10” Sub woofers or mid ranges and tweeters. It’s a sure way to blow your speakers.

Audio Output Section (does not apply to dB25 or dB45)

The audio output sections of the Class AB dB Series amplifiers feature Japanese studio grade, high current Bi-Polar audio transistors. Unlike other manufacturers who use a host of different type of transistors, not originally designed for audio output, i.e.: power supply transistors, motor control transistors to produce the audio signal, (You can only imagine what they sound like.) Rockville uses only true audio transistors in the audio section of these amplifiers. These transistors were designed and engineered to produce music. That’s why Rockville amplifiers clearly sound better. They are cleaner with lower distortion, higher current capable and more reliable. We challenge you to test listen a Rockville amplifier and hear the difference yourself.

The audio output sections of the Class D dB series amplifiers feature rugged, fast switching MOSFETs.

Power And Protection Circuitry

dB Series amplifiers feature our unique IC controlled protection circuitry. This sophisticated circuit constantly monitors the heat sink internal temperature and various voltages, adjusting the amp automatically and protecting it from dangerous conditions. The 2 LED’s located on the side of the amplifier provide indication of the amplifier status, the Power LED will light when the amplifier is receiving proper power, ground and remote voltages and the IC monitoring sequence indicates the amp is functional. In case the amplifier encounters a diagnostic condition as listed below, the second LED will light indicating a Diagnostic condition. When a diagnostic condition is sensed the amplifier will then turn into a self preservation mode and if the cause of the diagnostic condition is not corrected will eventually shut down. There are certain critical diagnostic conditions which will turn the amplifier off immediately.

Thermal Protection: When the amplifier reaches an unsafe operating temperature of 80 degrees Celsius the amplifier will turn off. Once the amplifier cools down to a safe temperature, it will automatically turn on again.

If you live in a hot climate we suggest installing additional cooling fans in your trunk to exhaust the hot air which can build up in the trunk this will help keep the ambient temperature in the trunk as low as possible so that your amps work flawlessly and without any musical interruption.

Speaker Short Circuit Protection: Should your speakers short circuit due to voice coil burn out, or should the amplifier sense an impedance too low to handle, the Protection LED will light, indicating a diagnostic condition. Turn off your system, disconnect one speaker at a time and try to determine which speaker might be faulty. Correct the condition and restart the amplifier. You must reset the amplifier by turning it OFF and then ON again by the Remote power connection after correcting a diagnostic condition. (Turn your radio off and then on again.)

Clipping or total shutdown may also be a result of a bad ground connection or loose ground. If you find that your speakers and speaker wires are not shorted, please check your ground and power connections.

Input Overload Protection: This circuit will either shutdown the amplifier completely or make the amplifier spurt on and off indicating that it is in a diagnostic condition. Turn the system off and reduce the gain on the amplifier or volume from your head unit, this should result in a corrected condition.

Features

DC Offset Protection: Should any DC voltage try to enter the amplifier via the speaker terminals it will cause the amplifier to shut down and not operate until this condition is remedied. This circuit will also protect damaging high DC voltages from reaching your speakers should your amplifier ever malfunction.

You must reset amplifier by turning it OFF and then ON again after correcting a diagnostic condition (turn your radio off and then on again). If the amplifier stays in protection after a reset, it is most likely faulty.

To reset the amplifier, you must first diagnose what caused the problem, correct the fault and restart the system.

Mute Circuit

dB Series amplifiers feature an anti-thump, mute and delay circuit. This eliminates irritating speaker damaging turn-on and turn-off transients normally experienced with less expensive amplifiers.

Battery Voltage

Rockville dB Series amplifiers are rated and regulated to 13.8 volts and below. Increasing voltage to 14.4 volts will increase the power output of the amplifier in the same proportion. Maximum input voltage is 14.4 volts while the minimum voltage is 12 volts.

DO NOT EXCEED 14.4 INPUT VOLTAGE.

Installation

Installation Basics

Before you begin your installation, disconnect the NEGATIVE(-) terminal from your car's battery. This safety precaution will avoid possible short circuits while wiring your amplifier. Rockville amplifiers operate on 12-volt negative ground systems only. It is recommended that you layout your sound system design on paper first. This will help you during the installation so that you will have a wiring flow chart and not miss-wire any of your components.

Mount the amplifier in the trunk or hatch area of your vehicle. Never install an amplifier in the engine compartment or on the firewall. Please be sure to leave breathing room around the amplifier heat sink so that it can dissipate the heat it produces efficiently. The amplifier can be installed either horizontally or vertically.

When mounting the amplifier on the trunk floor, be sure to watch for your gas tank, gas lines and electrical lines. Do not drill or mount any screws where they might penetrate the gas tank of your car.

Mounting The Amplifier

The dB Series amplifiers feature four mounting tabs located at the amplifiers four corners. Choose a convenient mounting location with unobstructed airflow. Using the supplied screws, gently mount the amplifier in to position.

DO NOT OVER TIGHTEN THE SCREWS.

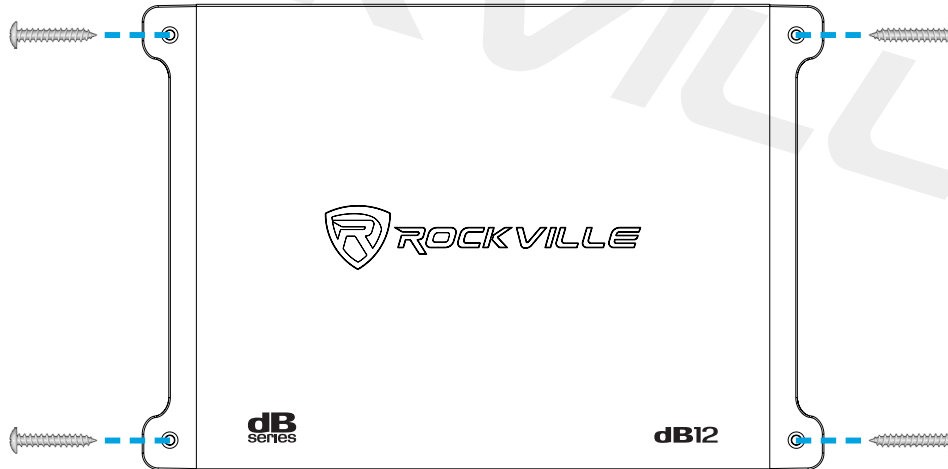

Wiring

The remote turn on connection is located on the barrier strip next to the power and ground connections. This connection is responsible for turning the amplifier on and off with the rest of the system. A smaller gauge wire can be used to make this connection to your radio's power antenna lead. Should your system not have any turn on leads, you can wire the remote terminal to an accessory lead, which turns the amplifier on with your car's ignition.

The majority of the dB Series amplifiers are supplied with built-in fuses. Never replace the built in or supplied external fuse with one of a larger value.

In order to protect the battery and electrical systems of your vehicle, construct a red wiring harness with a fuse and fuse holder located within 18" of the car battery. This fuse near the battery offers protection against damage from short circuits to the car chassis between the battery and the amplifier. This fused red power wire should be attached to the amplifier power terminal marked +12V. The wire harness should be made of red primary cable at least 8 gaug. The harness should terminate in a large ring terminal for connection directly to the positive terminal of the car battery. An optional second fuse can be installed closer to the amplifier for additional safety to the amplifier itself.

A second black color wire of equal gauge should be used as a ground connection to a welded chassis member. When connecting the ground wire make sure that there is no paint or other insulator blocking a good ground connection. When installing multiple amplifiers, mount them in close proximity so that they can all share the same ground point. Attach the black ground wire to the amplifier screw terminal marked GND. **Keep ground and power cables as short as possible.**

We have received amplifiers back to our service department with melted power/ground terminals. The cause of this is a bad ground connection. When there is a lack of good ground, heat builds up at the weakest point which happens to be the contact screw of the amplifier terminal. Over time the heat generated will begin to melt the terminal. It is a good practice to feel the power and ground wires with your hands, near their amplifier connection after having played the amp for a while. If the wires feel hot to the touch you probably have a bad or loose connection. If you are sure of your connections and the wires still feel hot to the touch, you should upgrade the gauge of wire to next heaviest gauge.

Connections can work loose due to vehicle vibrations. We recommend tightening all power and ground connections in the system wiring as well as on the amplifier terminals periodically, at least once every 2 months.

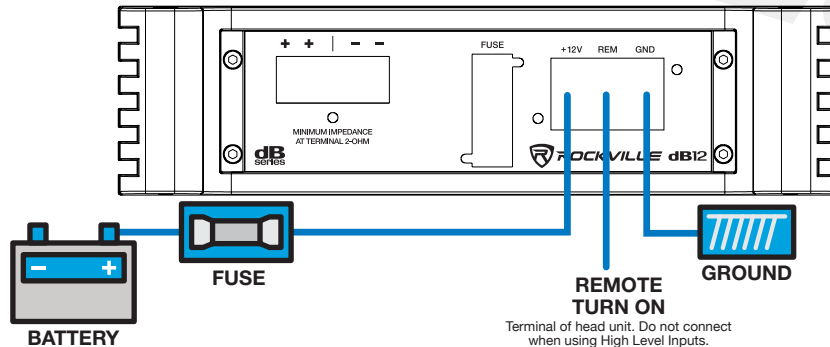

Settings

Adjusting The System

Once the system is operational, the first thing to do, is set all crossover points to approximate settings. In the case of the basic sub woofer system Low Pass filter crossover at 100Hz or so. Set the bass equalizer controls to 0 dB.

Now you should set the amplifiers Input Sensitivity adjustment. The knob accessible on the side of the amplifier marked LEVEL or INPUT LEVEL adjusts the input sensitivity. To adjust the input sensitivity, turn the control using a small flat head screwdriver fully counter clock wise to the minimum position. Do not apply any pressure while turning as this might break the control unit. Adjust your radio volume level to maximum volume. Now turn the level control on the amplifier clockwise towards the Maximum marking until audible distortion occurs. When you begin to hear any distortion in the sound, back down one notch and your amp is set. It is helpful to have a second person to help you set the gain.

When setting up a multi-amp system, set each amplifier's gain separately. Start off with the bass amplifier, then adjust the highs amplifier's level control to match.

Once you are satisfied with the level control settings, use any equalizer controls to adjust the system tonal level for personal preference. Keep in mind that after equalizing, you may have to go back and reset the amplifier's level controls.

The level control of any car amplifier should not be mistaken for a volume control. It is a sophisticated device designed to match the output level of your source unit to the input level of the amplifier. Do not adjust the amplifier gain to maximum unless your input level requires it.

If your unit has been professionally installed please do not change the gain settings set by the installer, he is the professional!

Your system can also be extremely sensitive to noise when the LEVEL is set to maximum and does not match your input signal. The gain adjustments need to be made only once when first setting up the system.

Using The Electronic Crossover - 4 Channel Models

The four and five channel models feature separate crossovers for channels 1-2 and 3-4. All the dB Series amplifiers feature 12dB per octave fully adjustable low-pass and high pass electronic crossovers.

Four Channel Amplifier Configurations

1. All four channels on High Pass for internal component speakers in doors and rear decks.
2. Channels 1 and 2 on High Pass for front component speakers, while channels 3 and 4 are wired to sub woofers.
3. Bridge channels 1 and 2 for single high power sub woofer channel. Bridge channels 3 and 4 for second high power sub woofer channel.

For Low Pass systems, set the CROSSOVER MODE switch to LOW PASS. Now the knob marked LPF will control the low pass frequencies from 50Hz to 250Hz. A frequent mistake made is setting the low pass frequency too low, especially when using vented sub woofer enclosures. We recommend that for most installations you do not set the frequency knob lower than

100Hz (the 12 o'clock position).

When using the amplifiers for component speakers or coaxial, you will want to set the CROSSOVER MODE switch to HIGH PASS. The HPF control knob adjusts the high pass frequencies between 60Hz and 1.2KHz. Do not attach tweeters directly to the amplifier even in the high pass mode without a secondary passive crossover to protect them.

Audio Preamp Input

The dB Series amplifiers feature RCA pre amp inputs. Run RCA cables from your sound source to the inputs of the amplifier. We suggest the use of high quality shielded RCA patch cords to help reduce and eliminate unwanted electrical noise to your system. Use good quality RCA interconnect cables. Cheaper cables usually have poor shielding that can cause interference pickup.

Be sure to run the RCA cables on the opposite side of the vehicle that you used to carry the power and ground leads of the amplifier.

Using The Built-In Low Pass Electronic Crossover

All the dB Series amplifiers feature 12dB per octave fully adjustable low-pass and high pass electronic crossovers.

For Low Pass sub woofer systems, set the CROSSOVER MODE switch to LOW PASS. Now the knob marked LPF will control the low pass frequencies depending on the model anywhere from 50Hz to 250Hz. A frequent error made is setting the low pass frequency too low, especially when using vented sub woofer enclosures. We recommend that for most installations you do not set the frequency knob lower than 80–100Hz (the 12 o'clock position).

When using the amplifiers for component speakers or co-axials, you will want to set the CROSSOVER MODE switch to HIGH PASS. The HPF control knob adjusts the high pass frequencies between 60Hz – 1.2KHz (dB25, dB45) or 15Hz – 4KHz (dB55). Do not attach tweeters directly to the amplifier, (even in the high pass mode) without a secondary passive crossover to protect them.

Subsonic Filtering

For sub woofer installations with a passive LP crossover, you can set the amplifier's CROSSOVER MODE selector to HIGH PASS while setting the HPF knob from the lowest setting to 50Hz, this will act as SUBSONIC FILTER for all signals below that setting. This is especially useful for vented enclosures where the port tuning frequency falls below the sub woofer tuning frequency to protect against sub woofer unloading.

ROCKVILLE

5 Channel Amp Configurations

5 Channel Amp with 2 Channel Input

If your head unit has one single pair of RCA outputs, input them in to the amplifiers Channel 1 and 2 input jacks and set the Input Mode Switch to 2Ch. The amplifiers preamp circuitry will automatically mix all the channels and output will occur on all 5 channels. There will be Left and Right balance with constant subwoofer but no Front to Rear Fader Control.

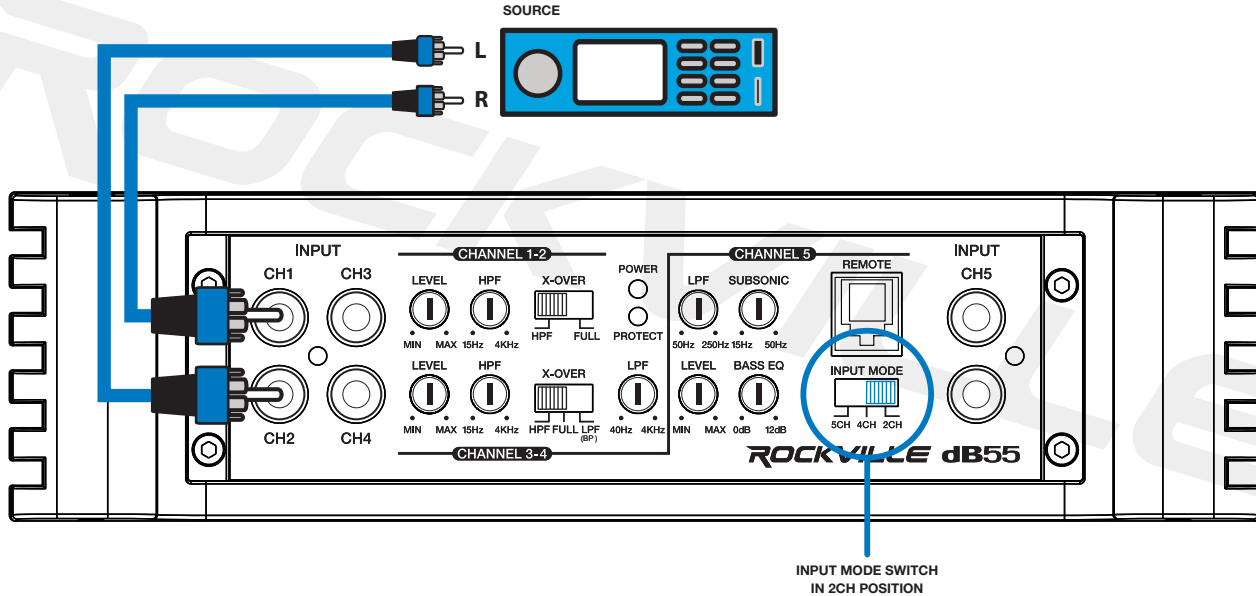

5 Channel Amp with 4 Channel Input

If your head unit has two pairs of RCA outputs, input Front Left and Front Right in to amplifier channels 1 and 2 input jacks. Rear Left and Rear Right in to amplifiers channels 3 and 4 input jacks. Set the Input Mode Switch to 4Ch. The amplifiers preamp circuitry will automatically mix all the channels and output will occur on all 5 channels. There will be Left and Right balance and Front to Rear fader with constant subwoofer.

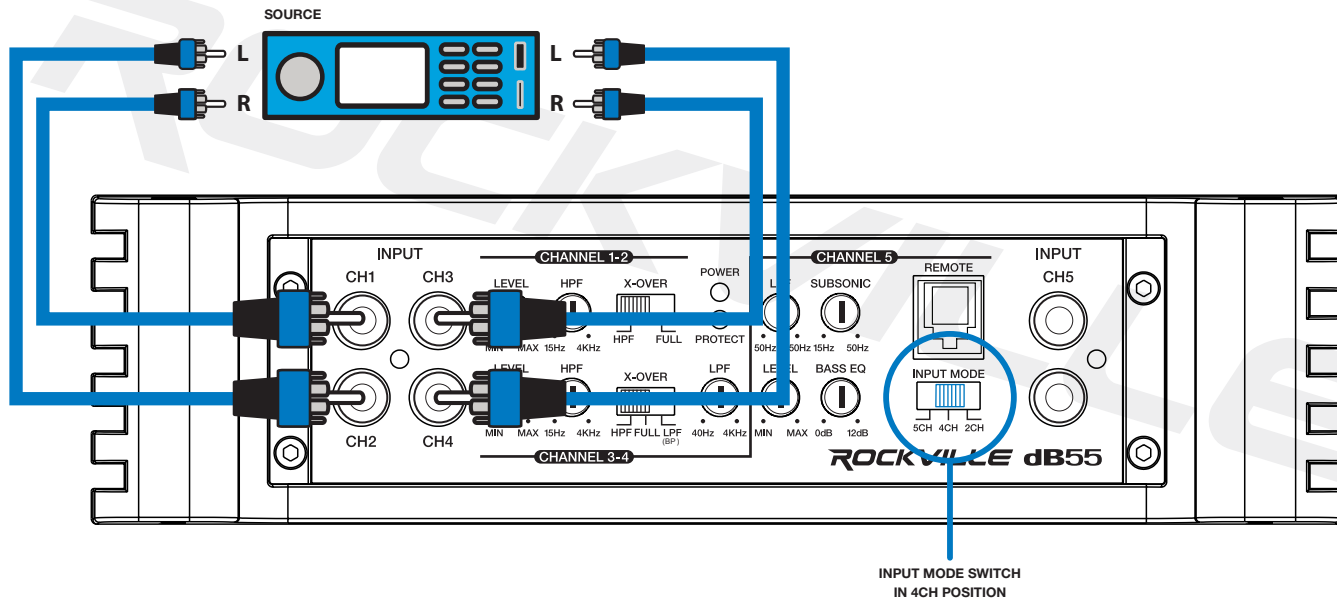

5 Channel Amp with 5 Channel Input

If your head unit has three pairs of RCA outputs, input Front Left and Front Right in to amplifier channels 1 and 2 input jacks. Rear Left and Rear Right in to amplifiers channels 3 and 4 input jacks. Subwoofer output in to channel 5. If your head unit has only a single subwoofer output, use a Y adaptor to feed both channel 5 inputs. Set the Input Mode Switch to 5Ch. The amplifiers preamp circuitry will automatically mix all the channels and output will occur on all 5 channels. There will be Left and Right balance, Front to Rear fader with independent subwoofer.

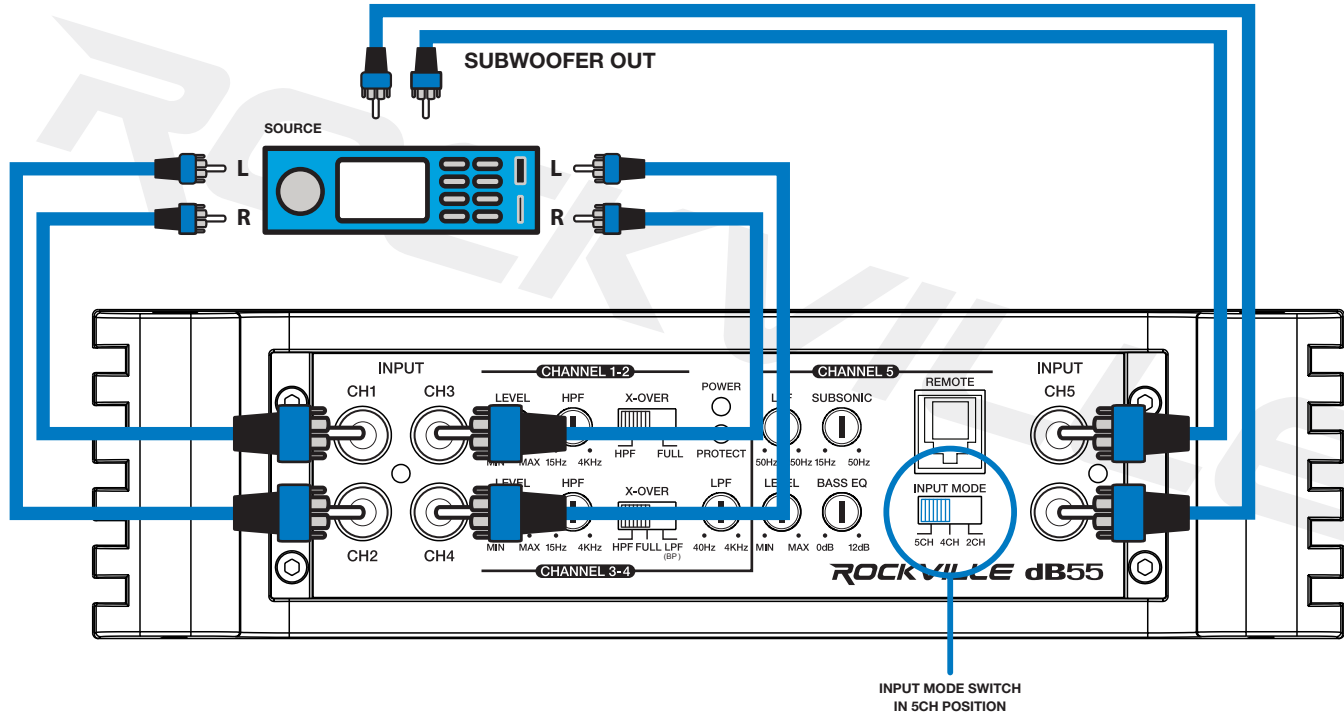

5 Channel Amp Speaker Wiring

Minimum impedance for channels 1 through 4 is 2 ohm stereo. Channel 5 minimum impedance is 2 ohm mono capable.

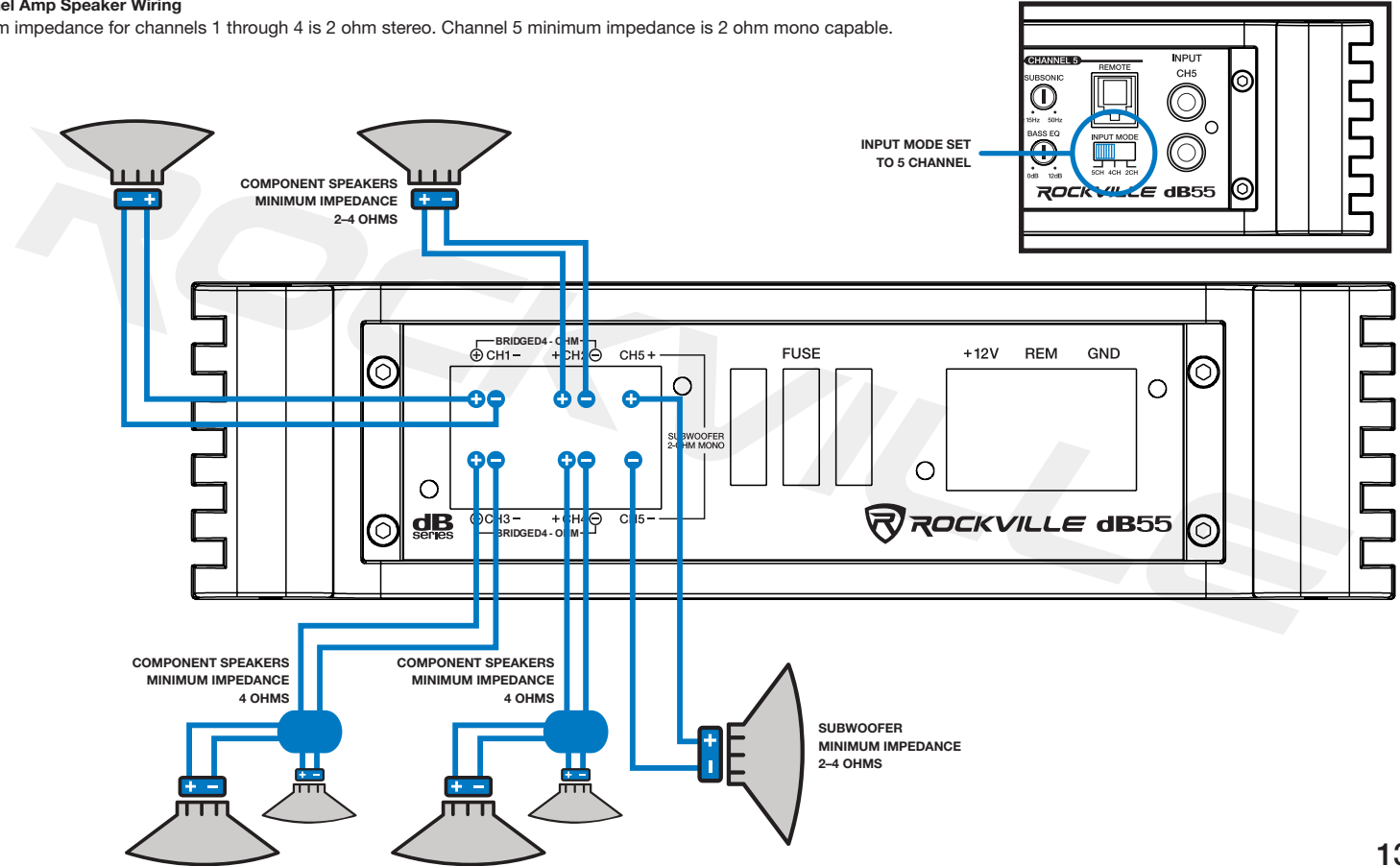

4 Channel Amp Configurations

4 Channel Amp with 2 Channel Input

If your head unit has one single pair of RCA outputs, input them in to the amplifiers channel 1 and 2 input jacks. The amplifiers preamp circuitry will automatically mix all the channels and output will occur on all 4 channels. There will be Left and Right balance but no Front to Rear Fader control.

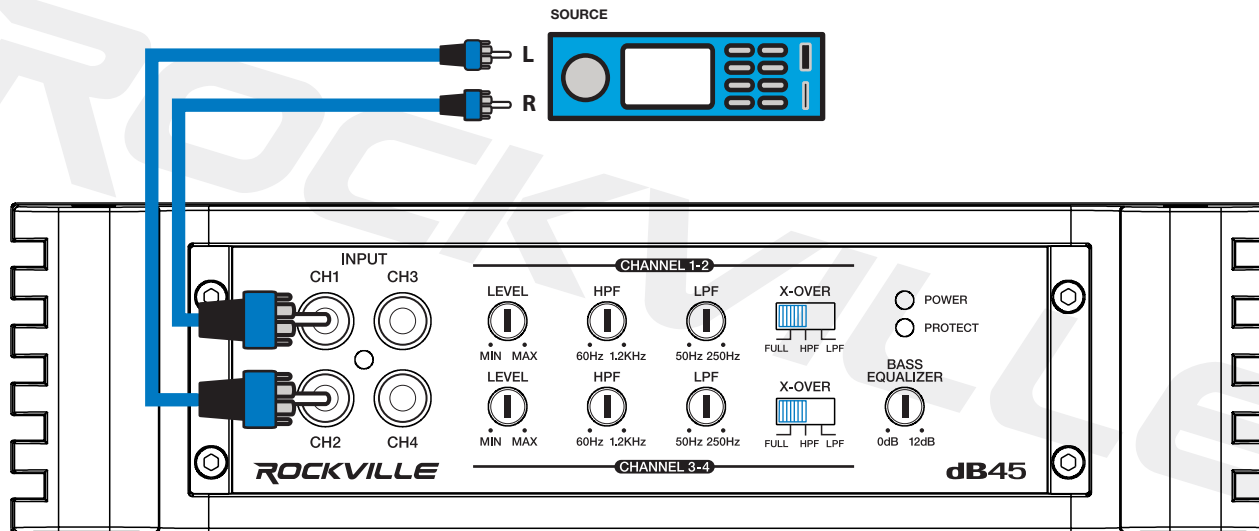

4 Channel Amp with 4 Channel Input

If your head unit has two pairs of RCA outputs, input Front Left and Front Right in to amplifier channels 1 and 2 input jacks. Rear Left and Rear Right in to amplifiers channels 3 and 4 input jacks. The amplifiers preamp circuitry will automatically mix all the channels and output will occur on all 4 channels. There will be Left and Right balance and Front to Rear fader.

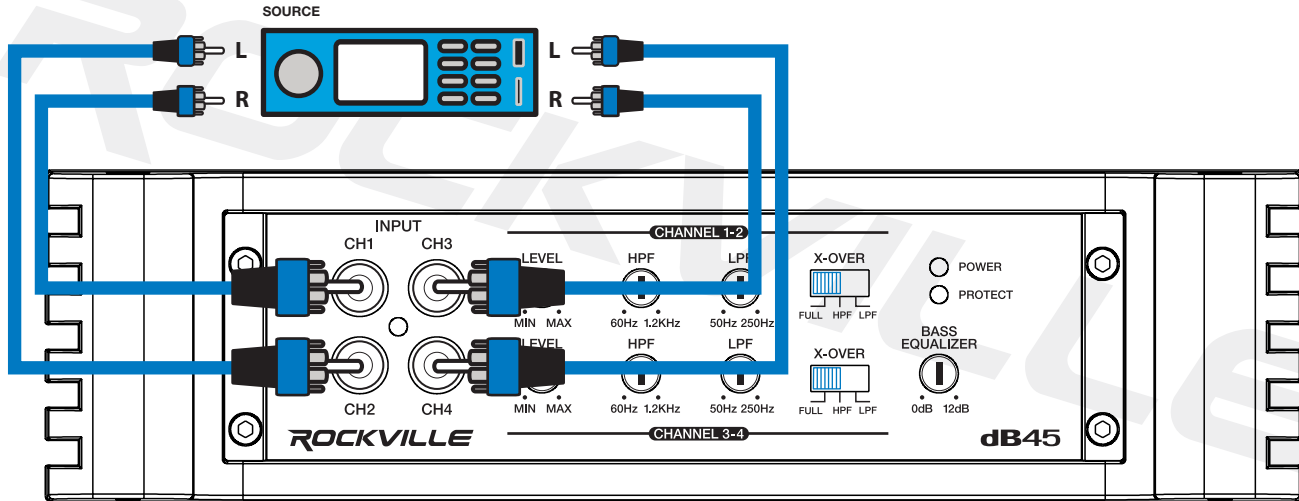

4 Channel Amp Speaker Wiring

Install any combination of speakers independently on all 4 channels being careful not to load any single channel below 2 ohm stereo. For typical 6" x 9" or 6.5" or component speaker installs, set the Crossover Mode Switches to Full Range.

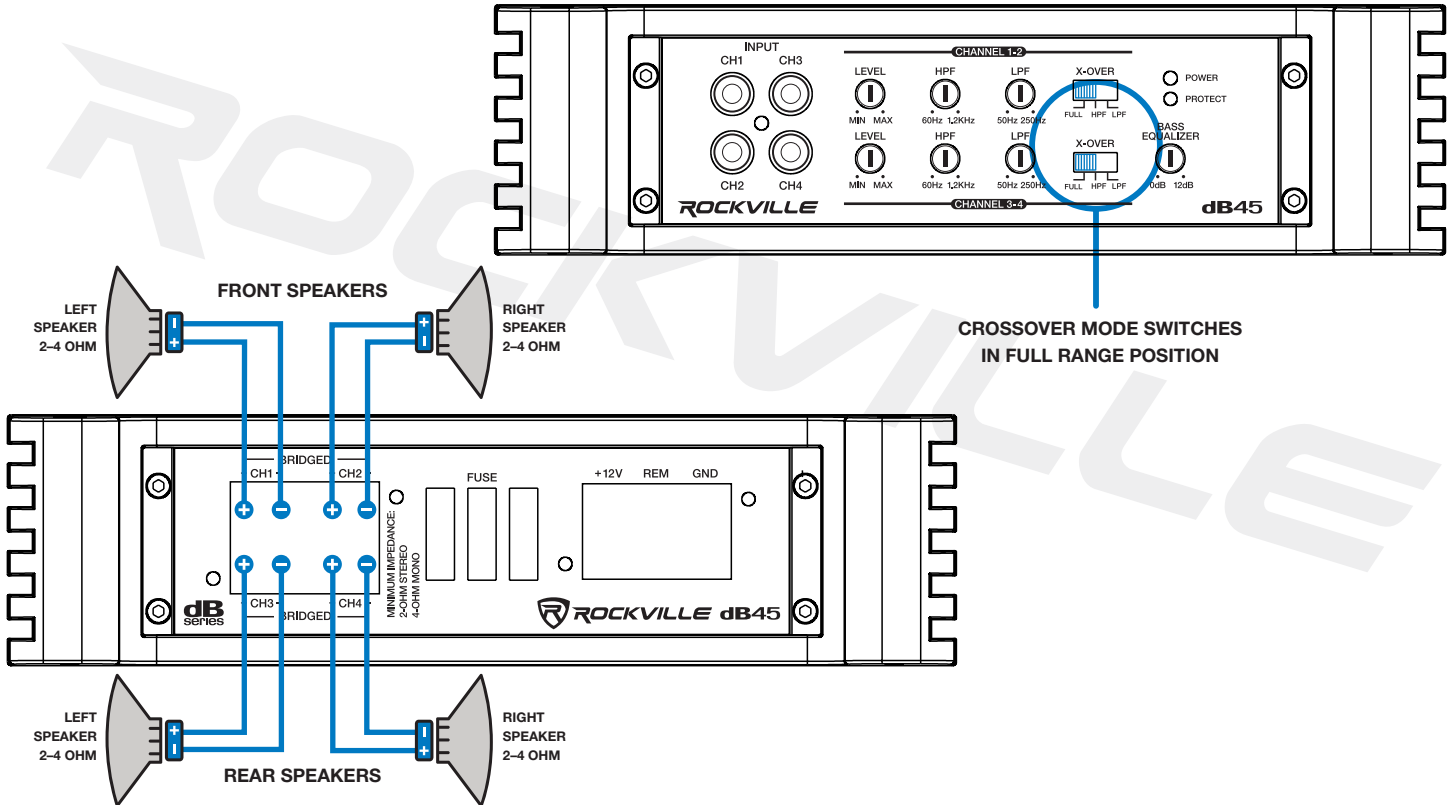

4 Channel Amp in 3 Channel Mode

Channels 1 and 2 should be wired to speakers no lower than 2 ohm loads per channel in stereo. Channel 3 and 4 should be bridged as per the diagram wiring the woofer to channel 3's positive (+) terminal and channel 4's negative (-) terminal. Set the crossover mode switch of channels 1 and 2 to either Full Range or High Pass, while channels 3 and 4 should be set to Low Pass.

**CHANNEL 1-2 CROSSOVER
SWITCH TO HPF OR FULL**

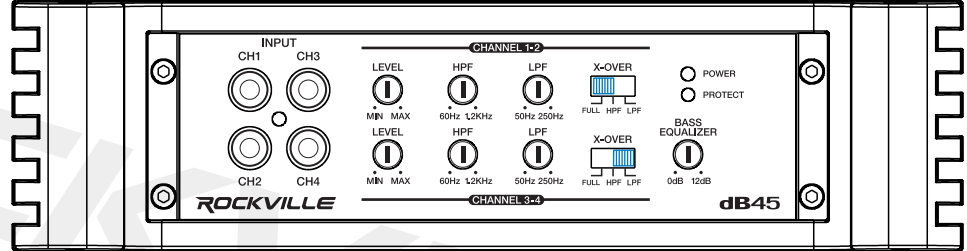

LEFT
SPEAKER
2-4 OHM



RIGHT
SPEAKER
2-4 OHM

**CHANNEL 3-4 CROSSOVER
SWITCH TO LPF**

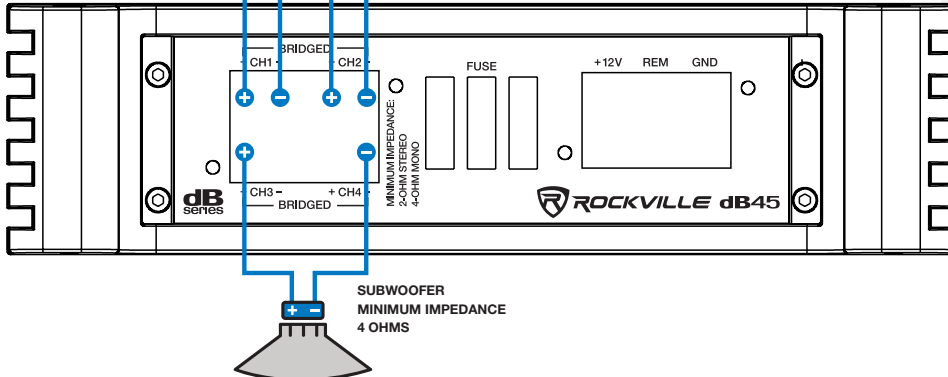

4 Channel Amp Bridged to 2 Channels

When bridging the four channel amplifier, make sure that your final woofer impedance on each bridged channel is no lower than 4 ohms. Set the Channel 1 and 2 Crossover Mode Switch to LPF; set the Channel 1&2 and Channel 3&4 Crossover Mode Switches to LPF. Begin by setting the crossover frequency controls to 100Hz and tuning from there.

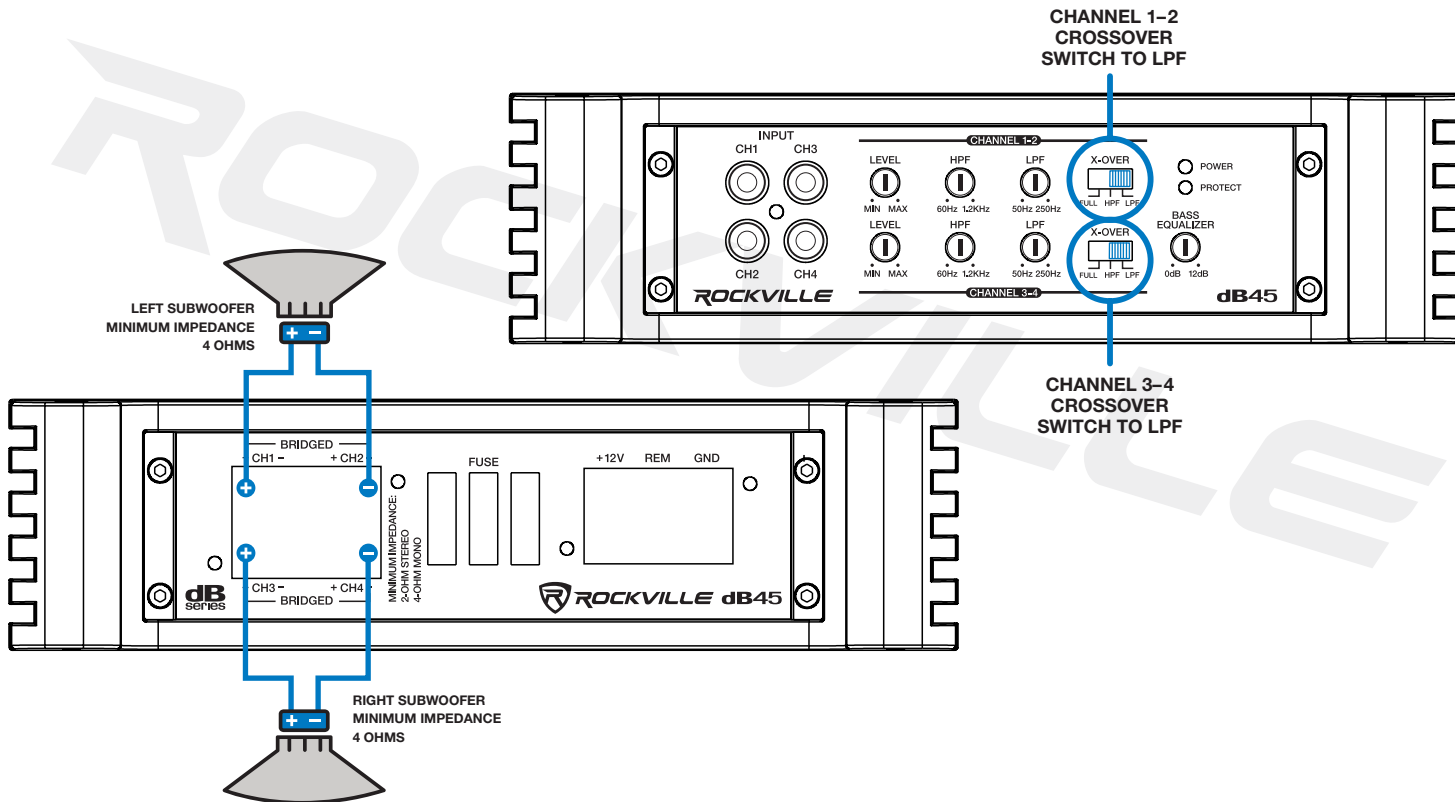

4 Channel Amp with Mixed Mono

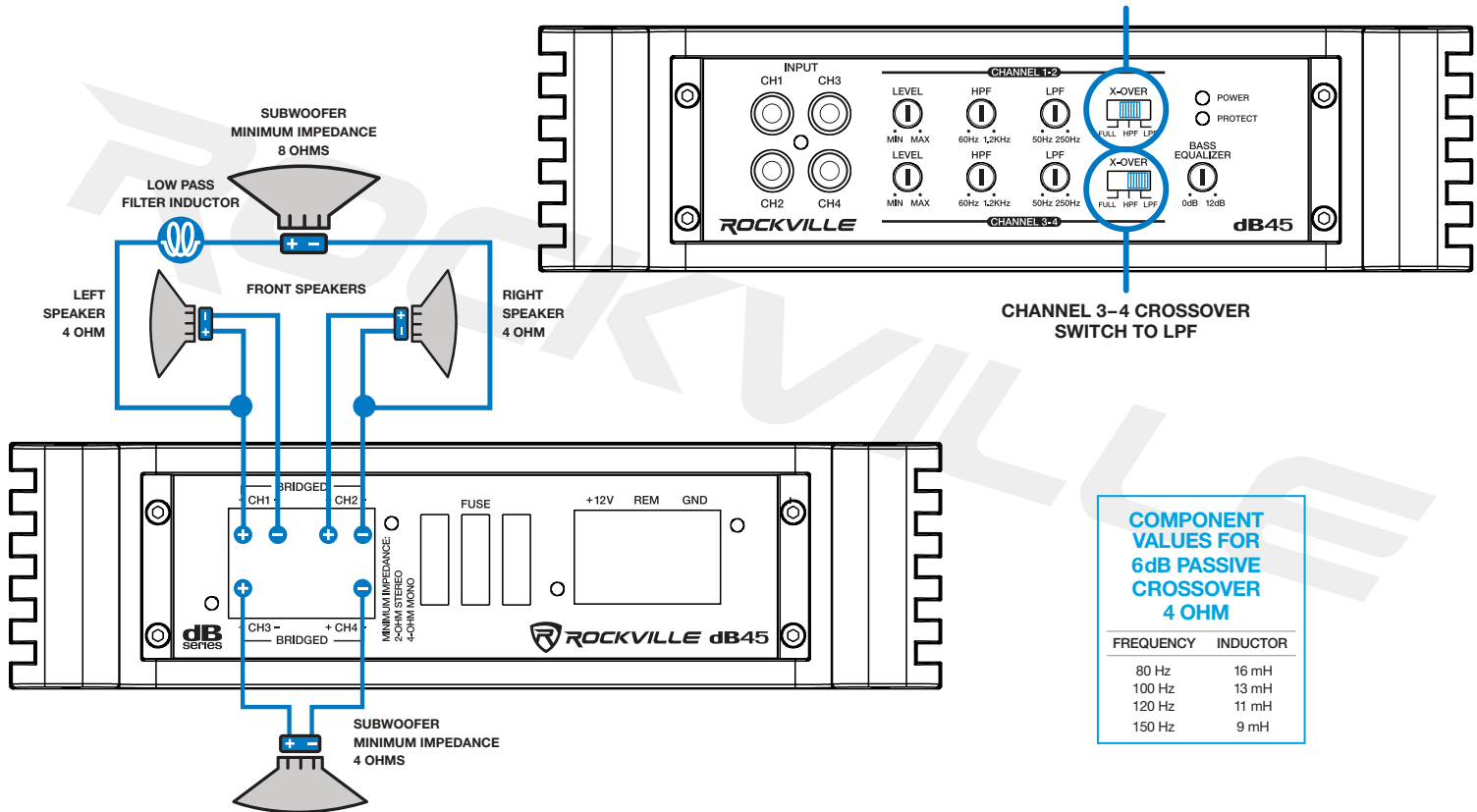

4 Channel Amp with Dual Mixed Mono

SYSTEM A FRONT SPEAKERS

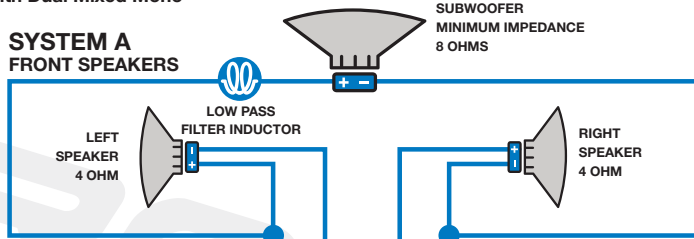

ALL CROSSOVER SETTINGS IN THIS MODE SHOULD BE SET TO FULL RANGE.

When configuring mixed mono systems, wire either using SYSTEM A or SYSTEM B depending on the use of external passive crossovers.

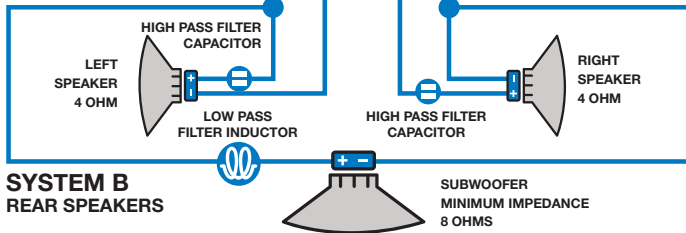
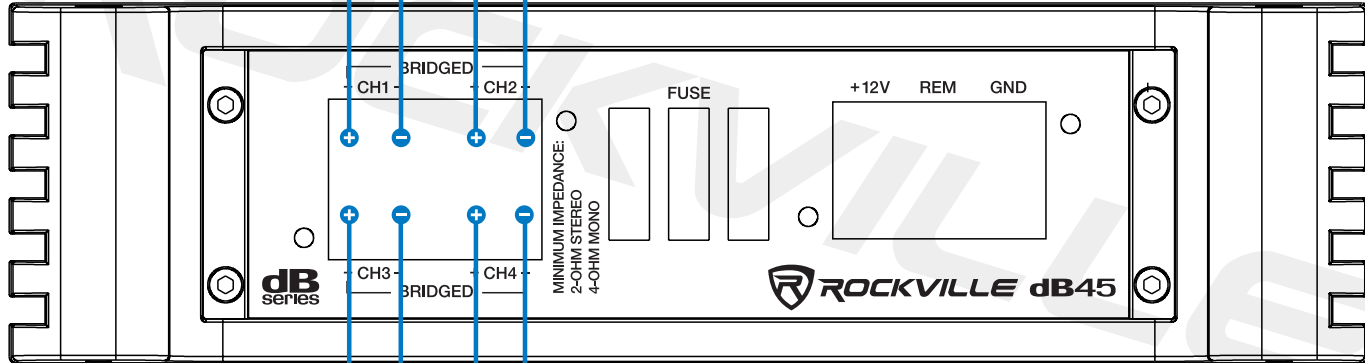

SYSTEM B REAR SPEAKERS

COMPONENT VALUES FOR 6dB PASSIVE CROSSOVER 4 OHM

FREQUENCY	INDUCTOR
80 Hz	16 mH
100 Hz	13 mH
120 Hz	11 mH
150 Hz	9 mH

ROCKVILLE

2 Channel Amp Configurations

2 Channel Amp Input

Connect your head unit's RCA outputs to the amplifiers Left and Right RCA input jacks. The dB25 2 channel amplifier features RCA pre-amp line outputs for feeding of a full-range signal to a secondary full-range amplifier in a multi-amp system.

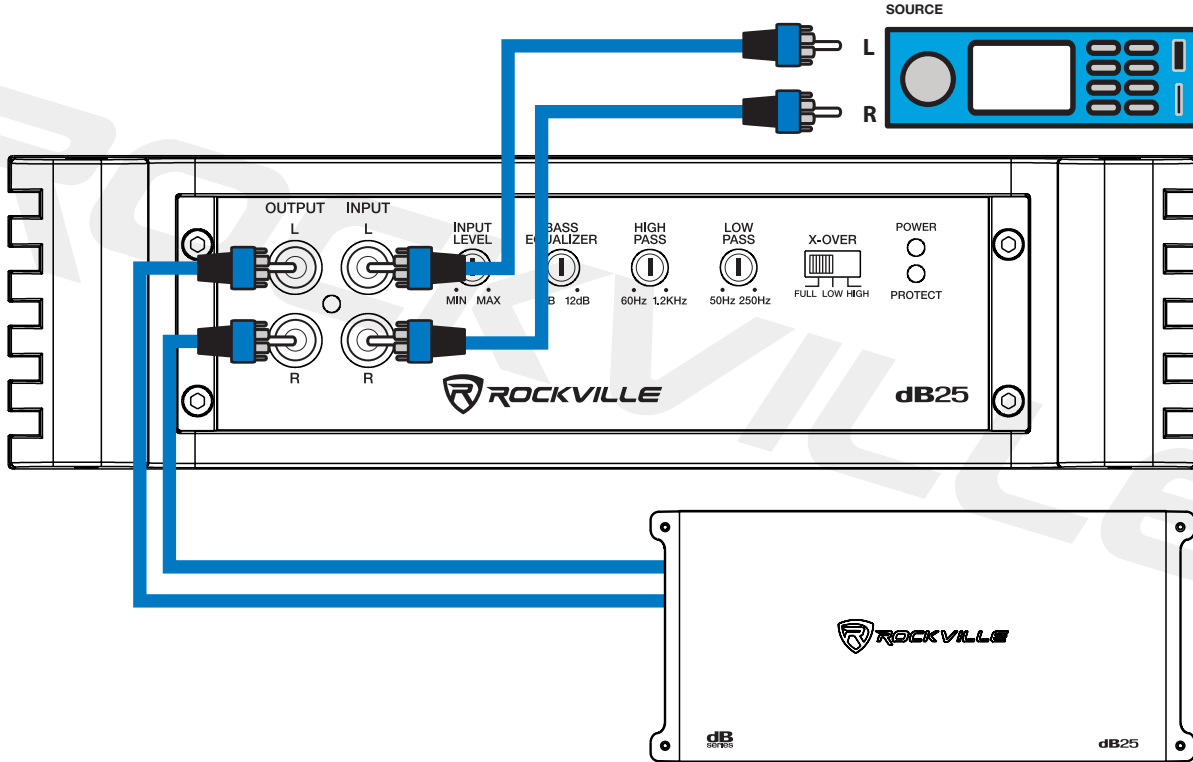

2 Channel Amp Speaker Wiring

Install any two or four speakers being careful not to load either channel below 2 ohm stereo. For typical 6" x 9" or 6.5" speaker installs, set the Crossover Mode Switch to Full Range. If you are using a system with a sub we recommend setting the crossover switch to high pass.

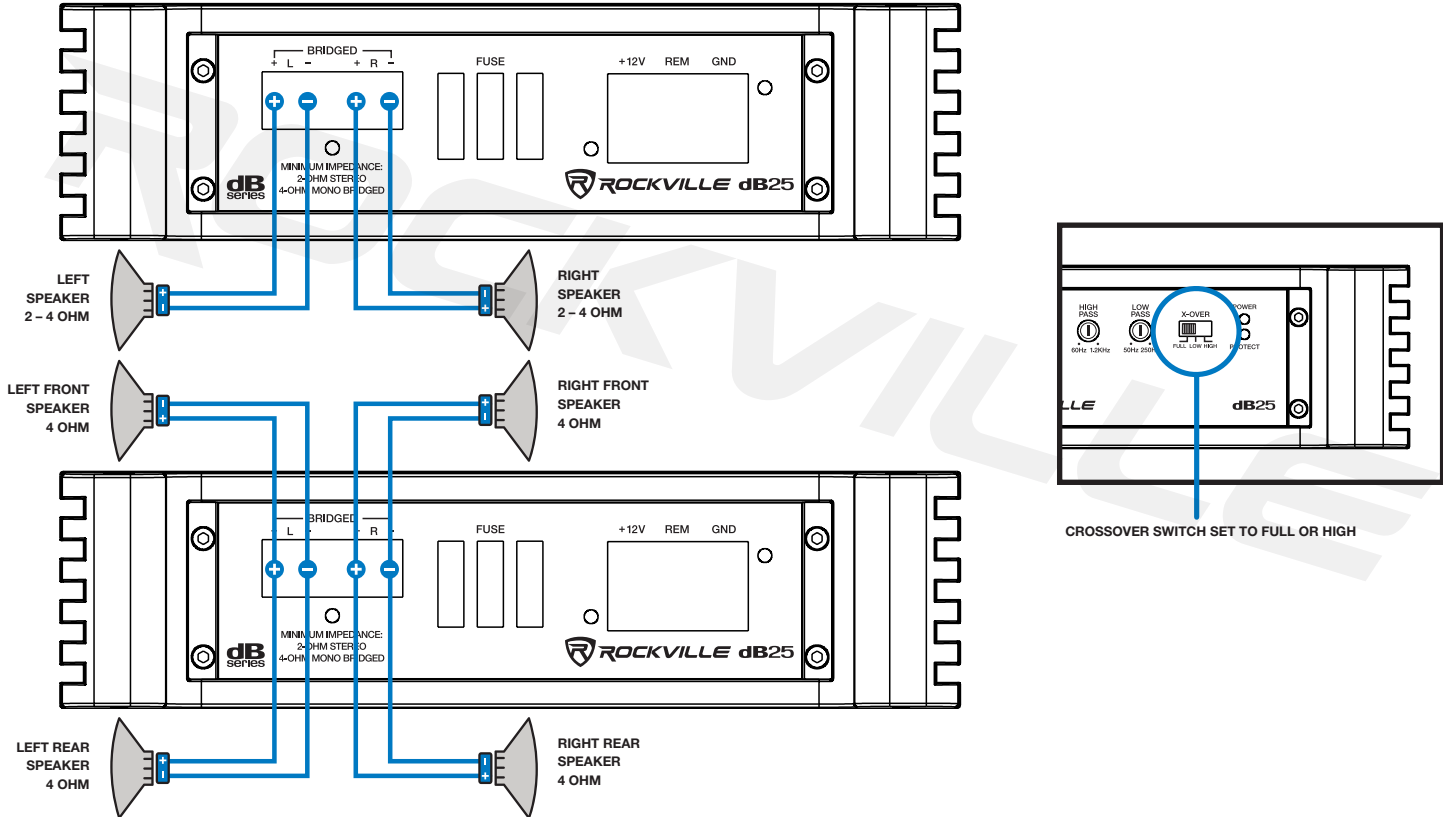

2 Channel Amp Subwoofer Wiring

Install any subwoofer being careful not to load the amp below 4 ohm mono. Set the Crossover Mode Switch to Low.

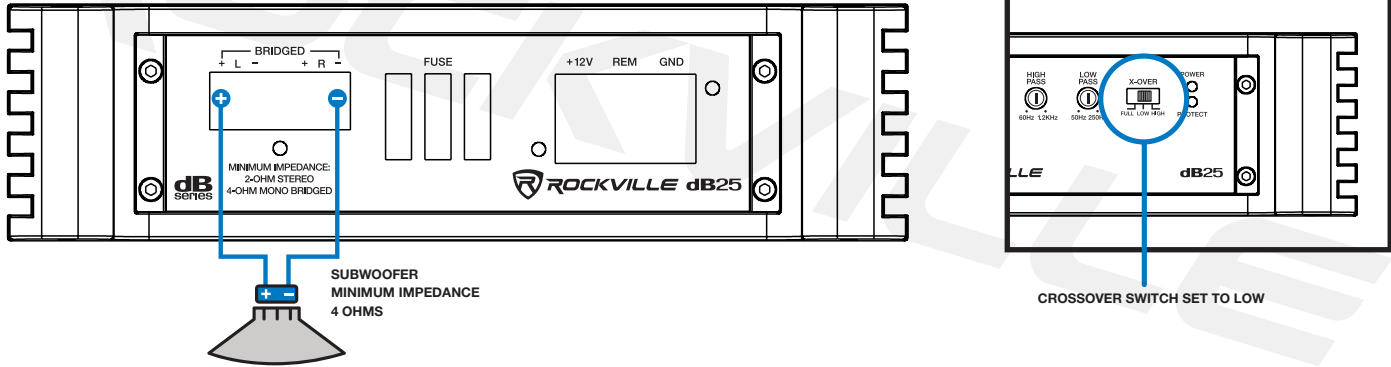

ROCKVILLE

Class D Monoblock 2 Ohm Amp Configurations

Class D Monoblock Amp Input

Connect your head unit's RCA outputs to the amplifiers Left and Right RCA input jacks. All dB series monoblock amplifiers feature RCA pre-amp line outputs for feeding of a full-range signal to a secondary full-range amplifier in a multi-amp system.

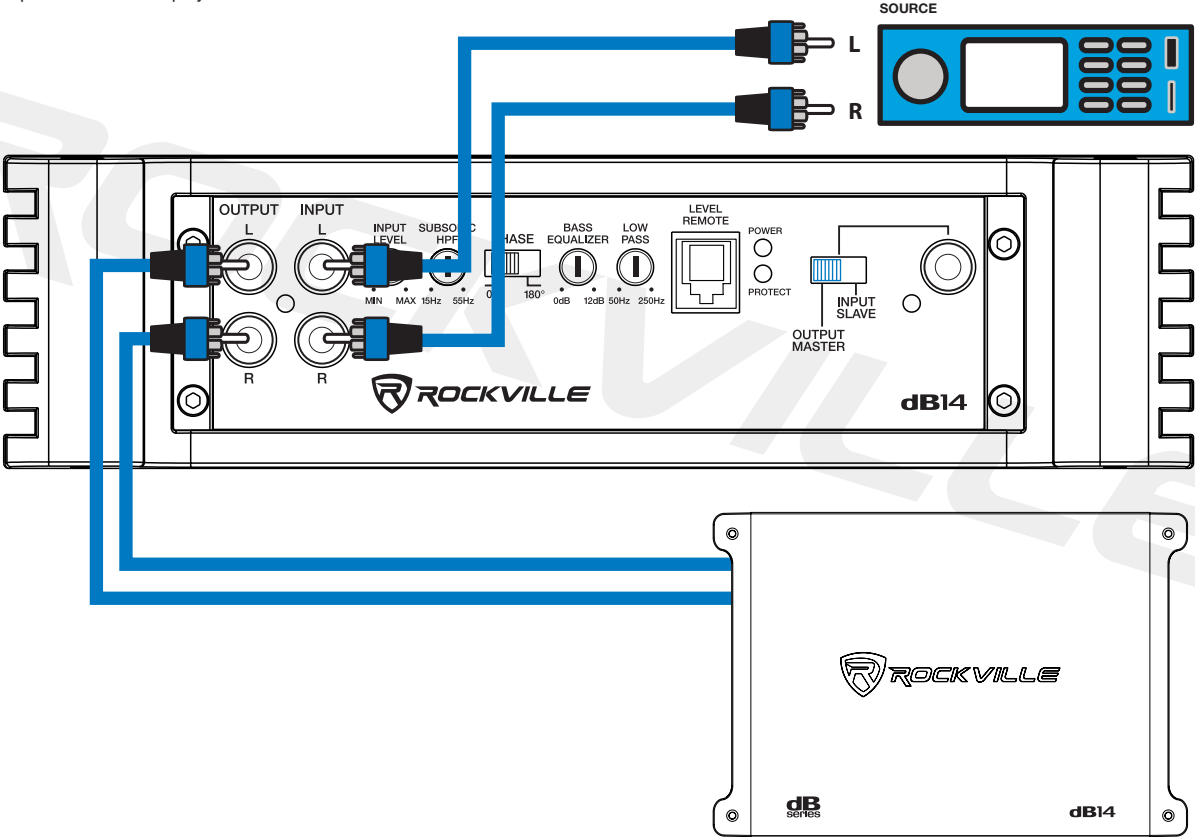

The dB16, dB15, dB14, dB13, and dB12 are all 2 ohm stable monoblock amplifiers. No matter how many woofers you choose to wire up to these models, **the final impedance should not fall below 2 ohm**. Please see page 30 and 31 for various speaker impedance configurations.

The dual positive and negative terminals are connected in parallel inside the amplifier. Connecting two speakers, each to one set of positive and negative terminals, will result in a parallel speaker connection. If only connecting one pair of speaker wires, it is not necessary to use both sets of connections.

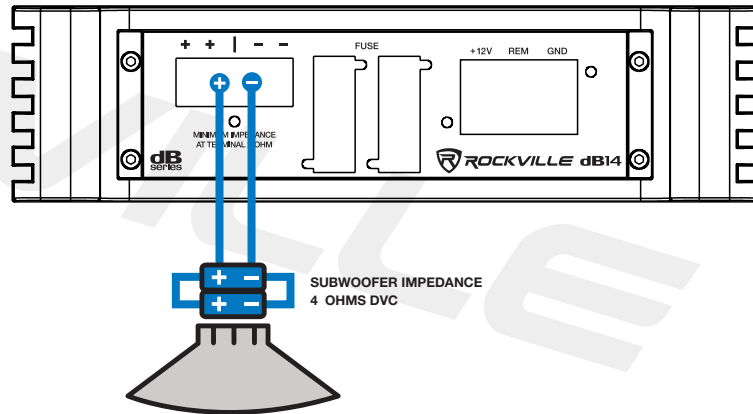
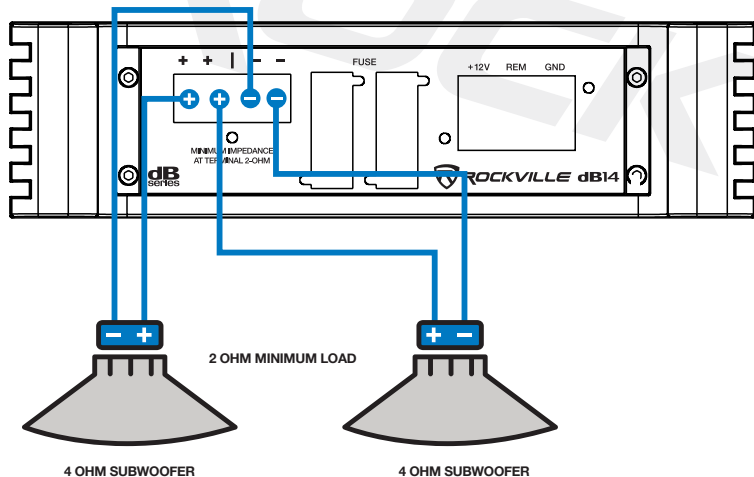

Twin Amp Bridging

The dB14, dB15, and dB16 can be bridged together for double the power output into a single 4-ohm load. Remember, when bridging amplifiers you must bridge them to a 4 ohm load.

Input the head unit signal into the MASTER amplifier and set the Bridged Mode switch to Output Master. Use a MONO RCA to RCA cable to send the fully processed signal from the MASTER amplifier to the secondary SLAVE amplifier and set the Bridged Mode switch to Input Slave. Do not input any RCA signals into the Slave amplifier left and right inputs. All crossover controls, Bass Drive, frequency settings, and subsonic filter settings will be controlled by the Master Amplifier including input gain levels. There is no need to gain match the two amplifiers, it will occur automatically. The remote dash bass control should be plugged in to the Master amplifier and it will control both amplifiers.

This same input/control system can be utilized when daisy chaining two amplifiers to two independent 2 ohm woofers as long as you don't bridge the two amplifiers outputs together.

You can only bridge 2 of the same amplifiers together. DO NOT bridge different models together.

When bridging two amplifiers together, the final impedance load of the bridged amplifiers should be no lower than 4-ohms. Double power will occur at 4-ohms. Master amplifiers positive (+) speaker terminal should be wired to the positive terminal of the subwoofer.

Slave amplifiers positive (+) speaker terminal should be wired to negative terminal of the subwoofer. Connect a heavy gauge wire (12 Gauge) between the negative (-) terminal of the Master amplifier and the Negative (-) terminal of the Slave amplifier.

When daisy chaining two amplifiers for independent woofers, wire up the the woofers as you would typically wire them when installing individual systems, even down to 2-ohm. By using the Master/Slave input configuration you gain the advantage of having one amplifier's preamp section control both amplifiers, eliminating the need to gain match and crossover match your system between amplifiers.

Twin Amp Bridging

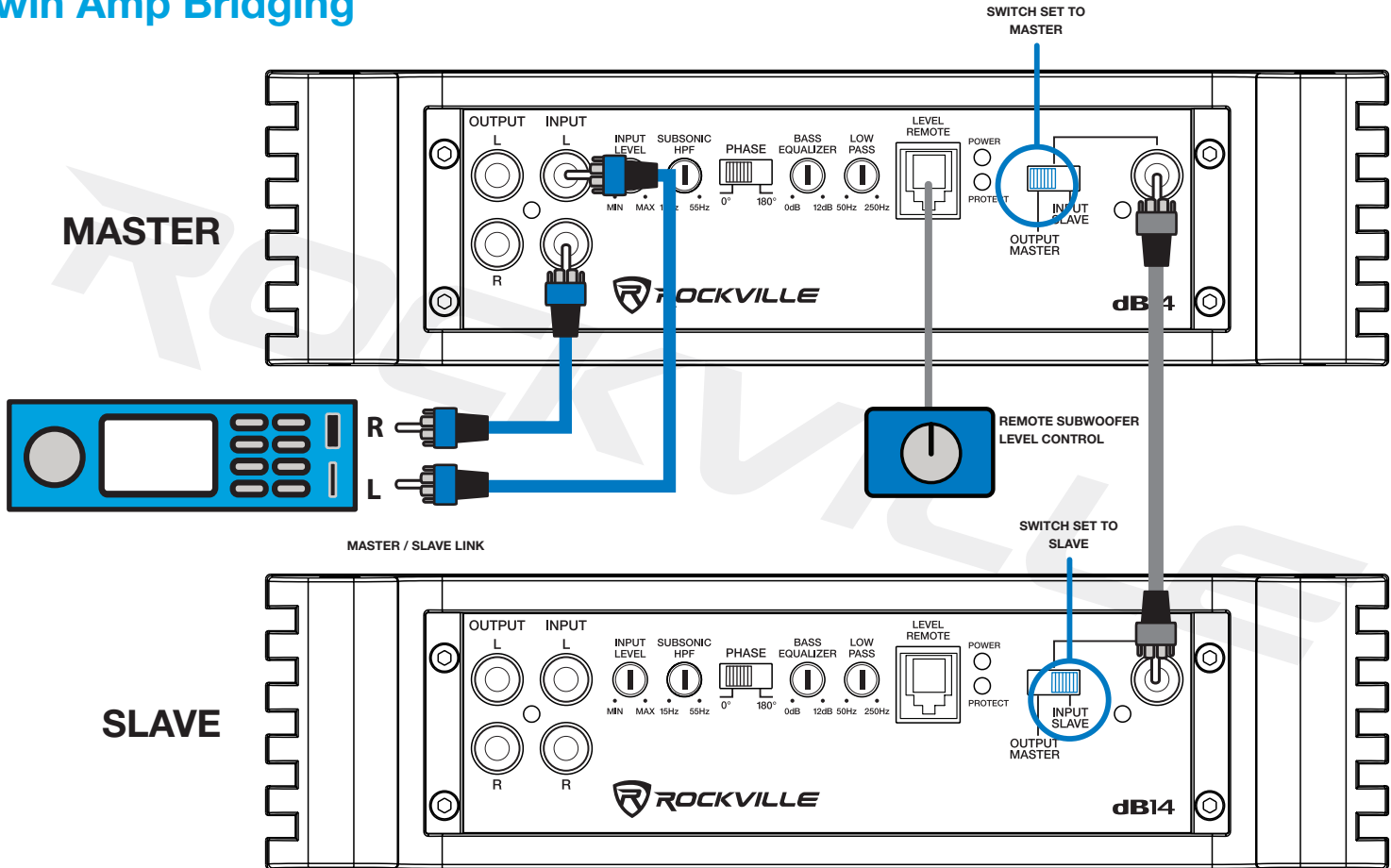

ROCKVILLE

Specifications

dB55 5 Channel Amplifier

- CEA Power Ratings:
 - 2 Ohm: 120 Watts x 4 + 500 Watts <1% THD+N
 - 4 Ohm: 80 Watts x 4 + 300 Watts <1% THD+N
 - RMS Power Ratings:
 - 2 Ohm: 240 Watts x 4 + 1000 Watts
 - 4 Ohm: 160 Watts x 4 + 600 Watts
 - Peak Power:
 - 2 Ohm: 480 Watts x 4 + 2000 Watts
 - 4 Ohm: 320 Watts x 4 + 1200 Watts
 - Dynamic Power: 4000 Watts
 - Minimum THD at Rated Power: < 0.05%
 - Frequency Response: 15Hz – 35KHz
 - S / N Ratio: >90dB
 - Damping Factor: > 100 @ 100Hz
 - 3x 40 Amp Fuses
 - Dimensions: (W x H x L) 9" x 2.4" x 18.6"
-
- High-Speed MOSFET Power Supply
 - Optical Coupler Class "AB" + "D" Technology
 - Studio-Grade Bipolar Output Stage Transistors
 - Rugged switching MOSFETs for Class D in CH5
 - Fully Adjustable 12dB/Octave Crossover with Differential Circuitry
 - Low Pass: (Ch3 – Ch4) 40Hz – 4KHz
(Ch5) 50Hz – 250Hz
 - High Pass: (Ch1 – Ch4) 15Hz – 4KHz
 - Subsonic Filter: (Ch5) 15Hz – 50Hz
 - Fully Adjustable 12dB Bass Equalizer
 - Mute and Delay Soft Start System
 - Remote Dashboard Subwoofer Control



dB45

- CEA Power Ratings:
 - 2 Ohm: 200 Watts x 4 Channels <1% THD+N
 - 4 Ohm: 135 Watts x 4 Channels <1% THD+N
 - 4 Ohm Bridged: 400 Watts x 2 Channels <1% THD+N
 - RMS Power Ratings:
 - 2 Ohm: 400 Watts x 4 Channels
 - 4 Ohm: 270 Watts x 4 Channels
 - 4 Ohm Bridged: 800 Watts x 2 Channels
 - Peak Power:
 - 2 Ohm: 800 Watts x 4 Channels
 - 4 Ohm: 540 Watts x 4 Channels
 - 4 Ohm Bridged: 1600 Watts x 2 Channels
 - Minimum THD at Rated Power: < 0.05%
 - Frequency Response: 10Hz - 50KHz
 - S / N Ratio: >90dB
 - Damping Factor: > 150 @ 100Hz
 - 3x 35 Amp ATC Fuses
 - Dimensions: (W x H x L) 9" x 2.4" x 21"
-
- High-Speed MOSFET Power Supply
 - Optical Coupler Class "AB" Technology
 - Studio-Grade Bipolar Output Stage Transistors
 - Fully Adjustable 12dB/Octave Crossover with Differential Circuitry
 - Low Pass: 50Hz – 250Hz
 - High Pass: 60Hz – 1.2KHz
 - Fully Adjustable 12dB Bass Equalizer
 - Mute and Delay Soft Start System
 - Full IC-Controlled Protection Circuitry
 - Status Mode LED Indicator
 - 8 Volt Preamp Circuitry



Specifications

dB25

- CEA Power Ratings:
 - 2 Ohm: 350 Watts x 2 Channels <1% THD+N
 - 4 Ohm: 230 Watts x 2 Channels <1% THD+N
 - 4 Ohm Bridged: 700 Watts x 1 Channels <1% THD+N
 - RMS Power Ratings:
 - 2 Ohm: 700 Watts x 2 Channels
 - 4 Ohm: 460 Watts x 2 Channels
 - 4 Ohm Bridged: 1400 Watts x 1 Channel
 - Peak Power:
 - 2 Ohm: 1400 Watts x 2 Channel
 - 4 Ohm: 920 Watts x 2 Channel
 - 4 Ohm Bridged: 2800 Watts x 1 Channel
 - Minimum THD at Rated Power: < 0.05%
 - Frequency Response: 10Hz – 100KHz
 - S / N Ratio: >90dB
 - Damping Factor: > 100 @ 100Hz
 - 3x 30 Amp ATC Fuses
 - Dimensions: (W x H x L) 9" x 2.4" x 19.4"
-
- High-Speed MOSFET Power Supply
 - Optical Coupler Class "AB" Technology
 - Studio-Grade Bipolar Output Stage Transistors
 - Fully Adjustable 12dB/Octave Crossover with Differential Circuitry
 - Low Pass: 50Hz – 250Hz
 - High Pass 60Hz – 1.2KHz
 - Fully Adjustable 12dB Bass Equalizer
 - Mute and Delay Soft Start System
 - RCA Line Output
 - Full IC-Controlled Protection Circuitry
 - Status Mode LED Indicator
 - 8 Volt Preamp Circuitry



dB16

- CEA Power Ratings:
 - 2 Ohm: 2000 Watts x 1 Channel <1% THD+N
 - 4 Ohm: 1200 Watts x 1 Channel <1% THD+N
 - RMS Power Ratings:
 - 2 Ohm: 4000 Watts x 1 Channel
 - 4 Ohm: 2400 Watts x 1 Channel
 - Peak Power:
 - 2 Ohm: 8000 Watts x 1 Channel
 - 4 Ohm: 4800 Watts x 1 Channel
 - Minimum THD at Rated Power: < 0.1%
 - Frequency Response: 15Hz - 250Hz
 - S / N Ratio: >90dB
 - Damping Factor: > 150 @ 100Hz
 - 200 Amp Maxi Fuse
 - Dimensions: (W x H x L) 9" x 2.4" x 19.8"
-
- High-Speed MOSFET Power Supply
 - Optical Coupler Class "D" Technology
 - Studio-Grade Bipolar Output Stage Transistors
 - Fully Adjustable 12dB/Octave Crossover with Differential Circuitry
 - Low Pass: 50Hz – 250Hz
 - Subsonic Filter: 15Hz – 55Hz
 - Fully Adjustable 12dB Bass Equalizer
 - Mute and Delay Soft Start System
 - Phase Control Switch
 - RCA Preamp Line Output
 - Master/Slave Amplifier Daisy Chain and Bridging Capability
 - Remote Dashboard Subwoofer Control
 - Full IC-Controlled Protection Circuitry
 - Status Mode LED Indicator
 - 8 Volt Preamp Circuitry



Specifications

dB15

- CEA Power Ratings:
 - 2 Ohm: 1500 Watts x 1 Channel <1% THD+N
 - 4 Ohm: 900 Watts x 1 Channel <1% THD+N
- RMS Power Ratings:
 - 2 Ohm: 3000 Watts x 1 Channel
 - 4 Ohm: 1800 Watts x 1 Channel
- Peak Power:
 - 2 Ohm: 6000 Watts x 1 Channel
 - 4 Ohm: 3600 Watts x 1 Channel
- Minimum THD at Rated Power: < 0.1%
- Frequency Response: 15Hz - 250Hz
- S / N Ratio: >90dB
- Damping Factor: > 150 @ 100Hz
- 150 Amp Maxi Fuse
- Dimensions: (W x H x L) 9" x 2.4" x 17.8"

- High-Speed MOSFET Power Supply
- Optical Coupler Class "D" Technology
- Studio-Grade Bipolar Output Stage Transistors
- Fully Adjustable 12dB/Octave Crossover with Differential Circuitry
- Low Pass: 50Hz – 250Hz
- Subsonic Filter: 15Hz – 55Hz
- Fully Adjustable 12dB Bass Equalizer
- Mute and Delay Soft Start System
- Phase Control Switch
- RCA Preamp Line Output
- Master/Slave Amplifier Daisy Chain and Bridging Capability
- Remote Dashboard Subwoofer Control
- Full IC-Controlled Protection Circuitry
- Status Mode LED Indicator
- 8 Volt Preamp Circuitry



dB14

- CEA Power Ratings:
 - 2 Ohm: 1000 Watts x 1 Channel <1% THD+N
 - 4 Ohm: 600 Watts x 1 Channel <1% THD+N
- RMS Power Ratings:
 - 2 Ohm: 2000 Watts x 1 Channel
 - 4 Ohm: 1200 Watts x 1 Channel
- Peak Power:
 - 2 Ohm: 4000 Watts x 1 Channel
 - 4 Ohm: 2400 Watts x 1 Channel
- Minimum THD at Rated Power: < 0.1%
- Frequency Response: 15Hz - 250Hz
- S / N Ratio: >90dB
- Damping Factor: > 150 @ 100Hz
- 100 Amp Maxi Fuse
- Dimensions: (W x H x L) 9" x 2.4" x 15.5"

- High-Speed MOSFET Power Supply
- Optical Coupler Class "D" Technology
- Studio-Grade Bipolar Output Stage Transistors
- Fully Adjustable 12dB/Octave Crossover with Differential Circuitry
- Low Pass: 50Hz – 250Hz
- Subsonic Filter: 15Hz – 55Hz
- Fully Adjustable 12dB Bass Equalizer
- Mute and Delay Soft Start System
- Phase Control Switch
- RCA Preamp Line Output
- Master/Slave Amplifier Daisy Chain and Bridging Capability
- Remote Dashboard Subwoofer Control
- Full IC-Controlled Protection Circuitry
- Status Mode LED Indicator
- 8 Volt Preamp Circuitry



Specifications

dB13

- CEA Power Ratings:
 - 2 Ohm: 750 Watts x 1 Channel <1% THD+N
 - 4 Ohm: 450 Watts x 1 Channel <1% THD+N
 - RMS Power Ratings:
 - 2 Ohm: 1500 Watts x 1 Channel
 - 4 Ohm: 900 Watts x 1 Channel
 - Peak Power:
 - 2 Ohm: 3000 Watts x 1 Channel
 - 4 Ohm: 1800 Watts x 1 Channel
 - Minimum THD at Rated Power: < 0.1%
 - Frequency Response: 15Hz - 250Hz
 - S / N Ratio: >90dB
 - Damping Factor: > 150 @ 100Hz
 - 80 Amp Maxi Fuse
 - Dimensions: (W x H x L) 9" x 2.4" x 14.7"
-
- High-Speed MOSFET Power Supply
 - Optical Coupler Class "D" Technology
 - Studio-Grade Bipolar Output Stage Transistors
 - Fully Adjustable 12dB/Octave Crossover with Differential Circuitry
 - Low Pass: 50Hz – 250Hz
 - Subsonic Filter: 15Hz – 55Hz
 - Fully Adjustable 12dB Bass Equalizer
 - Mute and Delay Soft Start System
 - Phase Control Switch
 - RCA Preamp Line Output
 - Remote Dashboard Subwoofer Control
 - Full IC-Controlled Protection Circuitry
 - Status Mode LED Indicator
 - 8 Volt Preamp Circuitry



dB12

- CEA Power Ratings:
 - 2 Ohm: 500 Watts x 1 Channel <1% THD+N
 - 4 Ohm: 300 Watts x 1 Channel <1% THD+N
 - RMS Power Ratings:
 - 2 Ohm: 1000 Watts x 1 Channel
 - 4 Ohm: 600 Watts x 1 Channel
 - Peak Power:
 - 2 Ohm: 2000 Watts x 1 Channel
 - 4 Ohm: 1200 Watts x 1 Channel
 - Minimum THD at Rated Power: < 0.1%
 - Frequency Response: 15Hz - 250Hz
 - S / N Ratio: >90dB
 - Damping Factor: > 150 @ 100Hz
 - 60 Amp Maxi Fuse
 - Dimensions: (W x H x L) 9" x 2.4" x 13.1"
-
- High-Speed MOSFET Power Supply
 - Optical Coupler Class "D" Technology
 - Studio-Grade Bipolar Output Stage Transistors
 - Fully Adjustable 12dB/Octave Crossover with Differential Circuitry
 - Low Pass: 50Hz – 250Hz
 - Subsonic Filter: 15Hz – 55Hz
 - Fully Adjustable 12dB Bass Equalizer
 - Mute and Delay Soft Start System
 - Phase Control Switch
 - RCA Preamp Line Output
 - Remote Dashboard Subwoofer Control
 - Full IC-Controlled Protection Circuitry
 - Status Mode LED Indicator
 - 8 Volt Preamp Circuitry



Woofer Wiring Guide

SVC configurations

★: Denotes recommended configurations.

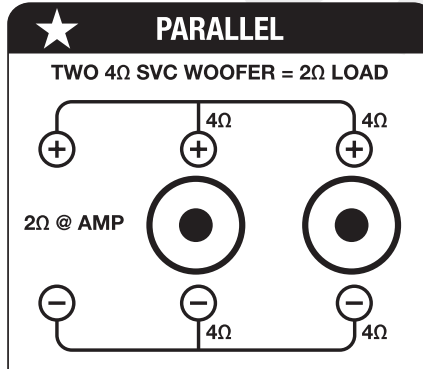
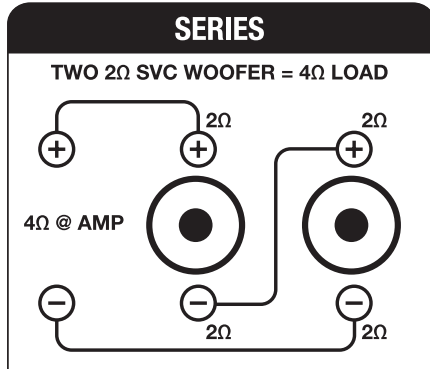
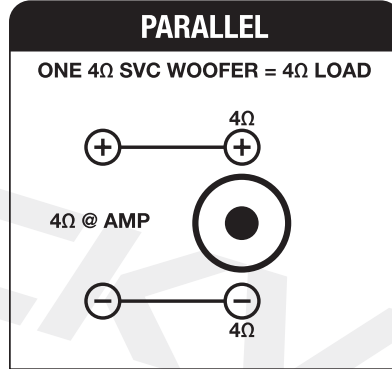
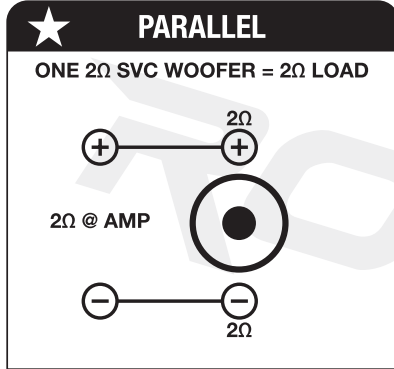

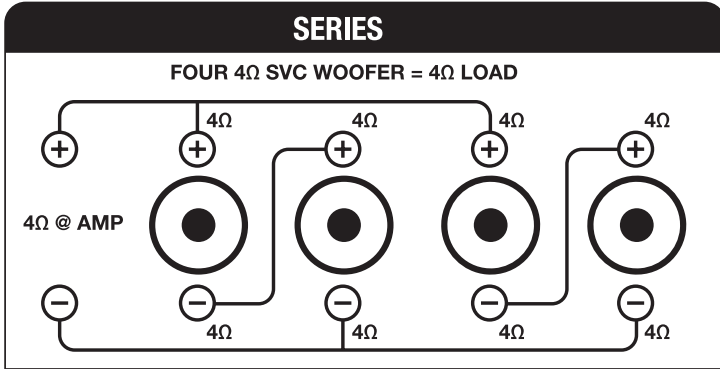
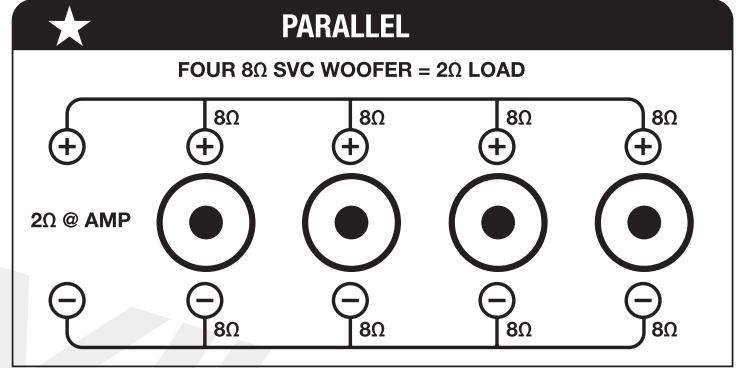
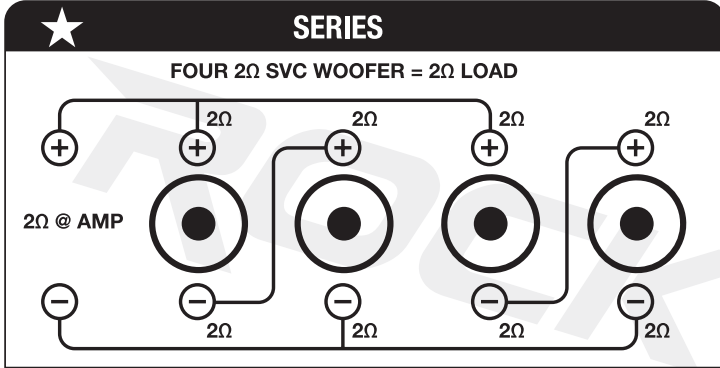

Woofer Wiring Guide

DVC configurations

★: Denotes recommended configurations.

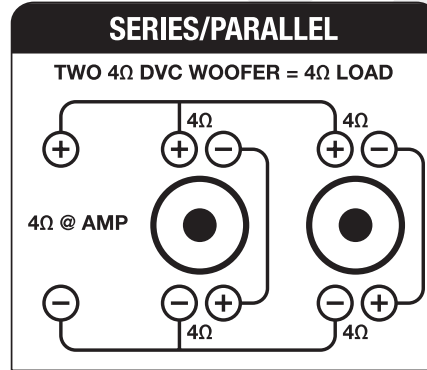
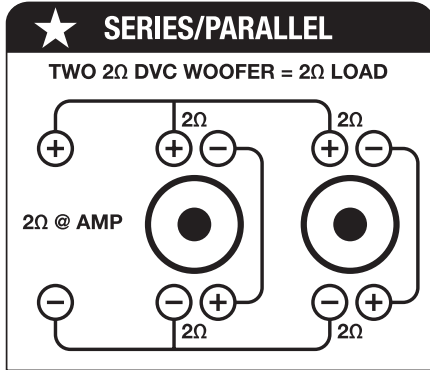
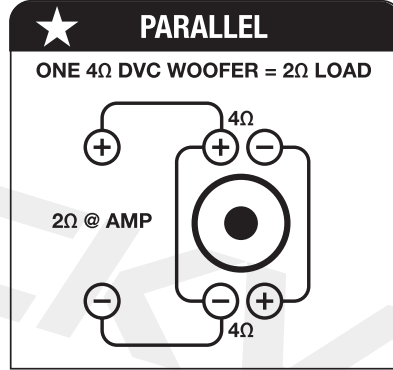
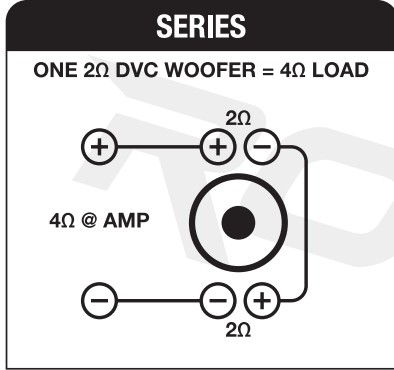



SERIES/PARALLEL

FOUR 4Ω DVC WOOFER = 2Ω LOAD

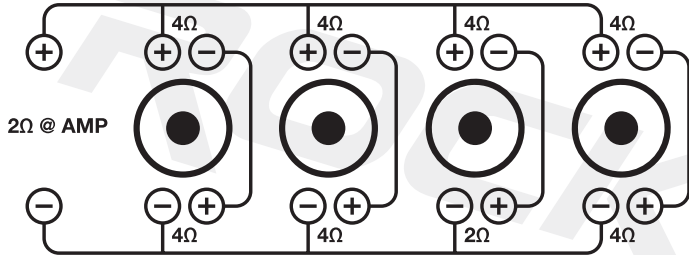

PARALLEL/SERIES

FOUR 2Ω DVC WOOFER = 4Ω LOAD

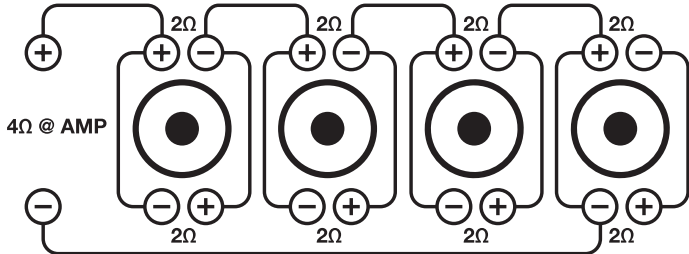



ROCKVILLE

©2018 ROCKVILLE // Features and specifications are subject to change and or improvement without notice. Though we tried our best to ensure that this manual is free and clear of errors please don't hold us responsible for printing errors.