

LIMITED WARRANTY

The Little Tikes Company makes fun, high quality toys. We warrant to the original purchaser that this product is free of defects in materials or workmanship for one year * from the date of purchase (dated sales receipt is required for proof of purchase) and all other parts are free of defects in material or workmanship for 90 days*. At the sole election of The Little Tikes Company, the only remedies available under this warranty will be the replacement of the defective part or replacement of the product. This warranty is valid only if the product has been assembled and maintained per the instructions. This warranty does not cover abuse, accident, cosmetic issues such as fading or scratches from normal wear, or any other cause not arising from defects in material and workmanship.

*Trampoline Warranty:

We warrant to the original purchaser that the frame of this product is free of defects in materials or workmanship for 1 year from the date of purchase, and all other parts are free of defects in material or workmanship for 90 days from the date of purchase (dated sales receipt is required for proof of purchase).

U.S.A and Canada: For warranty service or replacement part information, please visit our website at www.littletikes.com, call 1-800-321-0183 or write to: Consumer Service, The Little Tikes Company, 2180 Barlow Road, Hudson OH 44236, U.S.A. Some replacement parts may be available for purchase after warranty expires—contact us for details.

Outside U.S.A and Canada: Contact place of purchase for warranty service. This warranty gives you specific legal rights, and you may also have other rights, which vary from country/state to country/ state. Some countries/states do not allow the exclusion or limitation of incidental or consequential damages, so the above limitation or exclusion may not apply to you.

PLEASE SAVE SALES RECEIPT FOR PROOF OF PURCHASE

Please keep this manual as it contains important information.

© The Little Tikes Company,
an MGA Entertainment company.
LITTLE TIKES® is a trademark of Little Tikes in
the U.S. and other countries. All logos, names,
characters, likenesses, images, slogans, and
packaging appearance are the property of
Little Tikes.

Little Tikes Consumer Service
2180 Barlow Road Hudson, Ohio 44236 U.S.A.
1-800-321-0183

Printed in China

MGA Entertainment UK Ltd
50 Presley Way
Crownhill
Milton Keynes
MK8 0ES
Bucks, UK
0800 521 558

www.littletikes.com
www.littletikes.co.uk



Visit our website at
www.littletikes.com
to register your product and
to enter our sweepstakes.
(No purchase necessary)



Easy Store™ 3ft Trampoline

ENG

642265C

AGES 3-6 YEARS
ADULT ASSEMBLY AND SUPERVISION REQUIRED.



Illustrations are for reference only. Styles may vary from actual contents.

Assembly, Installation, Care, Maintenance and User Instructions

- You must thoroughly read the manual before assembling and using this trampoline.
- Maximum weight of the user shall not exceed 55 lbs. (25 kgs)
- Do not allow more than one person on the trampoline at any time. Collision hazard.
- Do not allow young children to use unless supervised by an adult.
- This product is intended for domestic indoor family use only.
- This product is intended for use by children ages 3 - 6 years.
- Do not eat while jumping.

Trampolines are great fun when used correctly. Most injuries are caused during the use of the trampoline, not because of their construction.

Read these instructions and warnings carefully and ensure you follow them at all times. Follow all assembly and maintenance instructions closely to ensure the equipment is safe to use and lasts as long as possible.

⚠️ WARNING: GENERAL

ADULT ASSEMBLY AND SUPERVISION REQUIRED

Read all instructions before using the trampoline. Warnings and instructions for the care, maintenance, and use of this trampoline are included to promote safe, enjoyable use of this equipment.

- This trampoline is only suitable for domestic indoor use.
- The trampoline is not intended to be buried in the ground.
- Adult supervision required. Do not leave children unattended.
- This product is intended for children 3 - 6 years of age and is not intended for use by children under 3 years of age due to their inability to use safely. Not recommended for children over 6 years of age.
- Limit one child at a time. Max. weight limit: 55 lbs. (25 kgs).
- The trampoline is designed for installation on flat surfaces with at least 2m clear space around the trampoline. Place the trampoline away from all objects such as walls, fences, structures, furniture and other objects.
- Do not place on a hard surface (i.e. concrete or asphalt) serious injury may occur.
- Ensure there is 3m (9.8 ft) of clear area above the trampoline as measured from the trampoline surface. This area should be free of objects such as wires, ceiling fans, branches, and other possible hazards.
- Ensure area under the bouncing surface is free of objects.
- Inspect the trampoline before each use. Make sure the frame padding is correctly and securely positioned. Replace any worn, defective, or missing parts.

⚠️ WARNING: USAGE

- Do not attempt stunts including somersaults, serious injury may occur if stunts are attempted on this trampoline. Landing on the head or neck can cause serious injury, paralysis or death, even when landing in the middle of the bed.
- Children and unpracticed users must always jump under supervision by an experienced person, it is strongly recommended to use spotters at all times.
- Do not allow more than one person on the trampoline. Use by more than one person at the same time can result in serious injury.
- Use trampoline only with mature, knowledgeable supervision.
- Remove glasses, watches, jewelry and chains, ornaments, clasps and other sharp objects. Empty your pockets before starting to jump.
- Do not use the trampoline in the dark.
- Do not put any objects or toys on the trampoline.
- Do not use when wet.
- Jumpers must wear socks, gymnastic shoes, or be barefoot when using the trampoline. Please be aware that street shoes or tennis shoes should NOT be worn while using the trampoline.
- Jumpers should remove all sharp objects prior to using the trampoline. Any type of sharp or pointed objects should be kept off the trampoline mat at all times.
- To break a bounce, all you need to do is flex your knees sharply before they come in contact with the mat of the trampoline. This technique should be practiced while you are learning each of the basic bounces. The skill of braking should be used whenever you lose balance or control of your jump.
- Misuse and abuse of this trampoline is dangerous and can cause serious injury! Trampolines being a rebounding device, propel the performer to unaccustomed heights and into a variety of body movements.
- Always inspect the trampoline before each use for worn-out mat, loose or missing parts.
- Climbing on and off the trampoline: it is a dangerous practice to jump from the trampoline to the floor or ground when dismounting, or to jump onto the trampoline when mounting. Do not use the trampoline as a springboard to other objects.
- Avoid bouncing too high. Stay low until bounce control and repeated landing in the center of the trampoline can be accomplished. Control is more important than height.
- While keeping the head erect, focus eyes on the trampoline toward the perimeter. This will help control bounce.
- Keep objects away which could interfere with the performer. Maintain a clear area around the trampoline.
- Bounce only when the surface of the bed is dry. Wind or air movement should be calm and gentle. The trampoline must not be used in gusty or severe winds.
- Bounce in the center of the bed.
- Secure the trampoline against unauthorized use.
- Limit the time of continuous usage (make regular stops).
- Modifications made by the consumer to the original trampoline (e.g. the adding of an accessory) shall be carried out according to the instructions of the manufacturer.
- Make sure that the hook-and-loop fasteners are closed correctly during use of trampoline.

Care, maintenance and use instructions

MUST be read carefully before using the trampoline!

This trampoline was designed and manufactured with quality materials and craftsmanship. If proper care and maintenance is provided, it will provide all jumpers with years of exercise, fun, and enjoyment as well as reduce the risk of injury. Please follow the guidelines listed below:

- Please make sure that only one person at any one time uses the trampoline.
- In order to prevent the trampoline mat from getting cut or damaged please do not allow any pets onto the mat.
- Always inspect the trampoline before each use for worn, abused or missing parts. A number of conditions could arise that may increase your chances of getting injured.

Please be aware of:

- Punctures, holes, or tears in the trampoline mat
- Sagging trampoline mat
- Loose stitching or any kind of deterioration of the mat
- Bent or broken frame parts, such as legs or poles
- Damaged, missing, or insecurely attached frame pad
- Protrusions of any types (especially sharp) on the frame, springs, or mat.

IF YOU FIND ANY OF THE PREVIOUS CONDITIONS, OR ANYTHING ELSE THAT YOU FEEL COULD CAUSE HARM TO ANY USER, THE TRAMPOLINE SHOULD BE DISASSEMBLED OR SECURED FROM USE UNTIL THE CONDITION(S) HAS BEEN RESOLVED.

Carry out checks and maintenance of the main parts (frame, suspension system, bed, pads and enclosure) at regular intervals. If these checks are not carried out the trampoline could become dangerous.

It is of particular importance that these be followed at the beginning of each season, as well as at regular intervals during the usage season.

- Check all nuts and bolts for tightness and tighten when required.
- Check all coverings for bolts and sharp edges and replace when required.
- Check for evidence of wear or deterioration and replace if needed in accordance with these instructions.

ASSEMBLY - Folding & Storing

⚠️ WARNING:

Perform a complete inspection of the trampoline to make sure all parts are assembled and attached properly.

Read this entire manual and make sure all jumpers completely understand all of the safety rule printed in the manual and on the various warning signs.

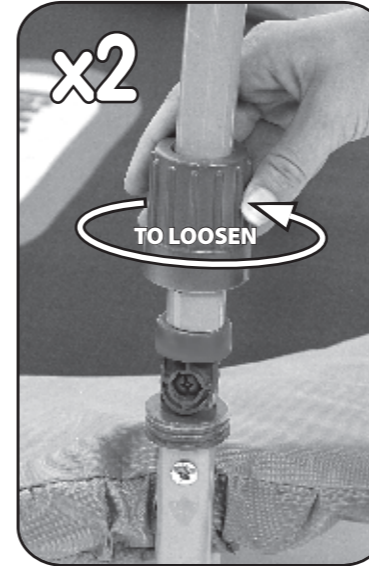

ASSEMBLY - Folding Handle

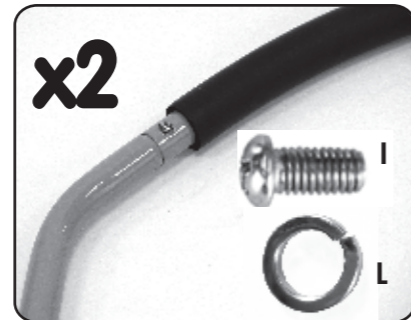
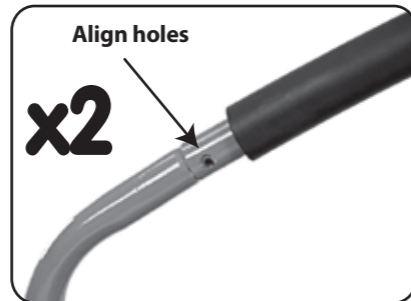
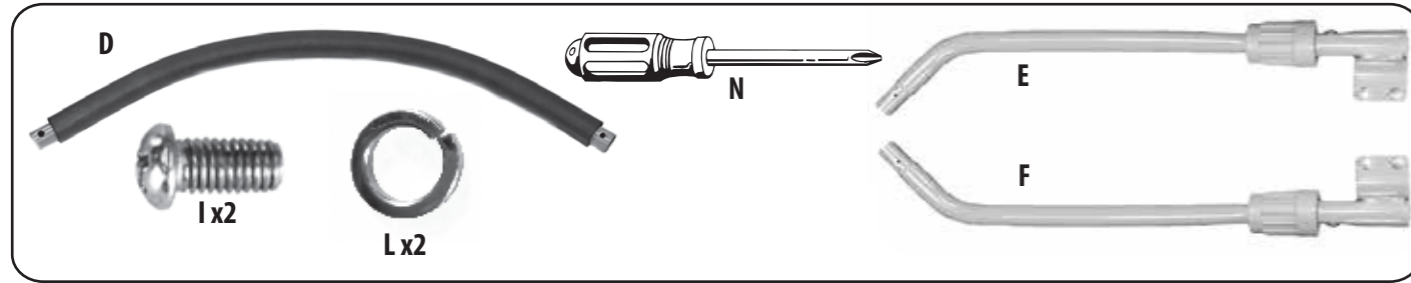

Place **small spring washer (L)** onto **1/2" screw (I)**. Insert and tighten using Phillips screwdriver (N). Repeat on other side.

ASSEMBLY - Legs Continued





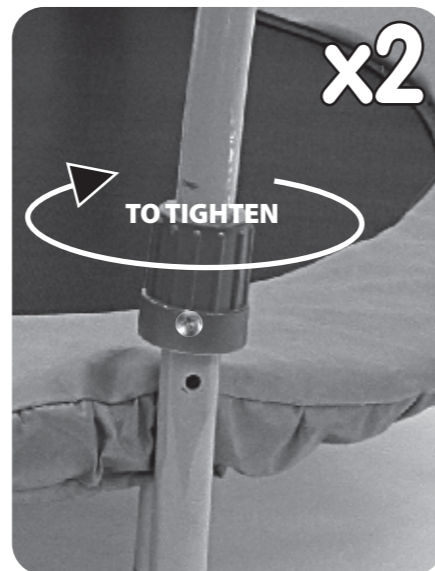









Use the wrench (M) to tighten the nuts on the folding safety bars (E, F).



Twist clockwise to lock the safety bar in the upright position.

CONTENTS

Please refer to this chart for parts description and letters. The assembly steps use these descriptions and letters as references for your convenience. Make sure that you have all parts listed.

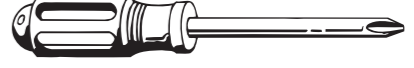
 <p>(1) Trampoline Mat & Frame</p>	 <p>(5) Leg Stops</p>
 <p>(3) Frame Legs</p>	 <p>(2) 1 1/2" Bolts</p>
 <p>(2) Folding Handle Legs</p>	 <p>(2) 1/2" Screws</p>
 <p>(1) Curved Safety Bar with Foam</p>	 <p>(2) Cap Nuts</p>
 <p>(1) LEFT Folding Safety Bar</p>	 <p>(2) Big Spring Washers</p>
 <p>(1) RIGHT Folding Safety Bar</p>	 <p>(2) Small Spring Washers</p>
	 <p>(1) Wrench</p>
	 <p>(1) Screwdriver</p>

ASSEMBLY - Opening Trampoline

⚠️ WARNING: ADULT ASSEMBLY REQUIRED

Two people are required for assembly. Prior to assembly, this package contains small parts: hardware which is a choking hazard and may contain sharp edges and sharp points. Keep away from children until assembled.

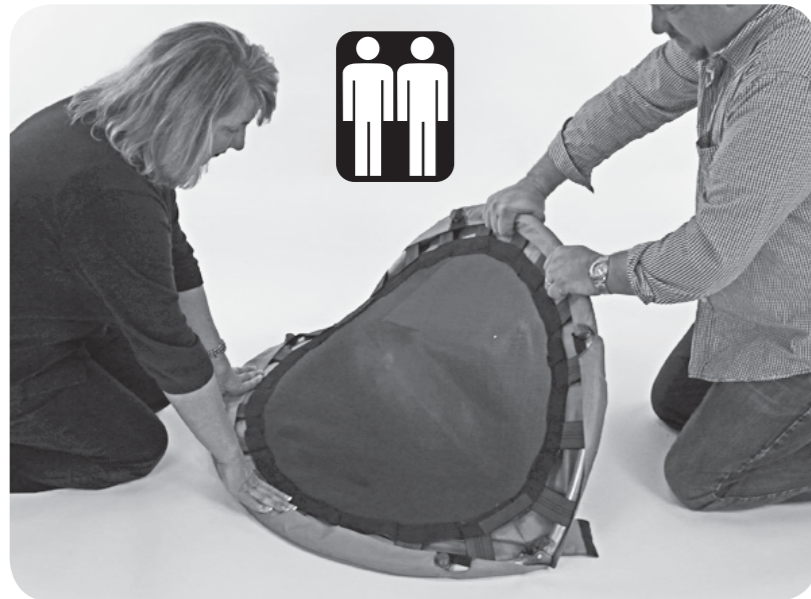

⚠️ Always use 2 or more strong adults to perform this step and keep face away from rails. Failure to do so may allow the rails to spring back into the folded position and cause harm.

- Keep fingers away from the end of the rails near the hinged area when unfolding the trampoline.

1. Lay the folded trampoline on the floor in its still folded position.
2. Hold one side firmly down.
3. Using steady pressure, with hands open and fingers extended, pull on the other side to open.
4. Open trampoline fully, until hinges snap into place.

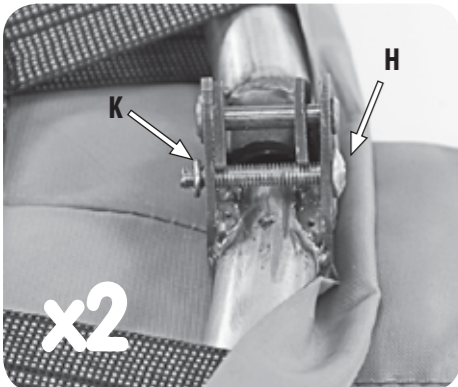
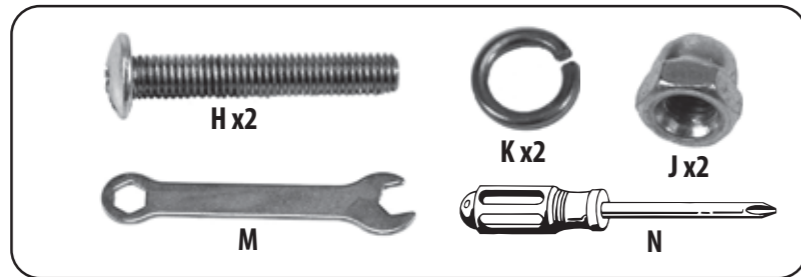

Insert 1 1/2" bolt (H) through hinge. Place (1) big spring washer (K) onto end of bolt.

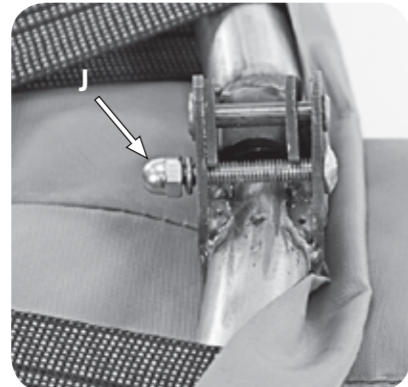

Place (1) cap nut (J) onto end of bolt.

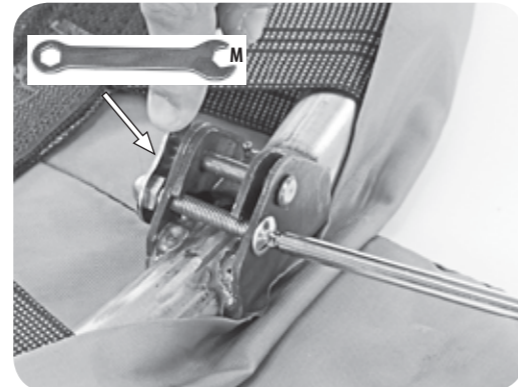

Hold the cap nut using the wrench (M). Tighten using the Phillips screwdriver (N). Repeat these steps to secure hinge on opposite side.



Fold flap over the hinge and secure velcro in place. Repeat for other hinge.



Remove all protective end caps from screw threads and discard. Keep out of reach of children.

ASSEMBLY - Legs

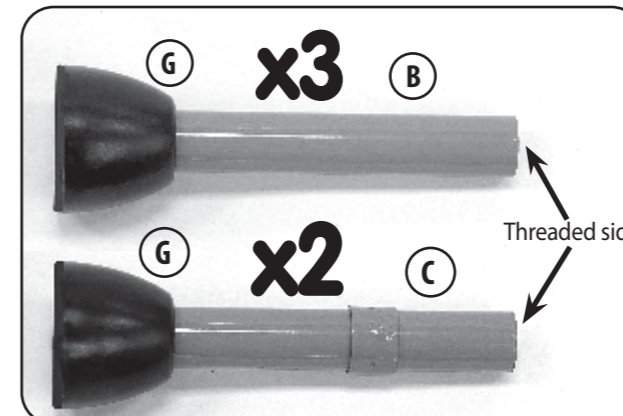
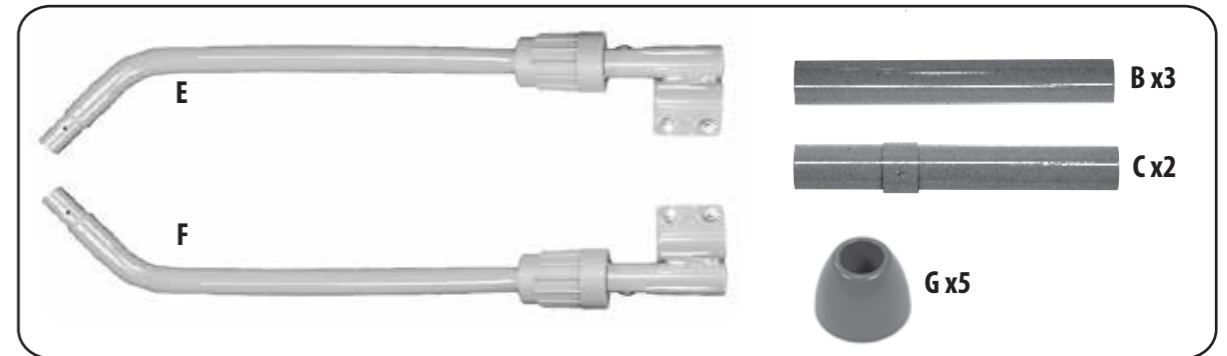

Attach leg stop (G) to each of 3 frame legs (B) and 2 folding handle legs (C).

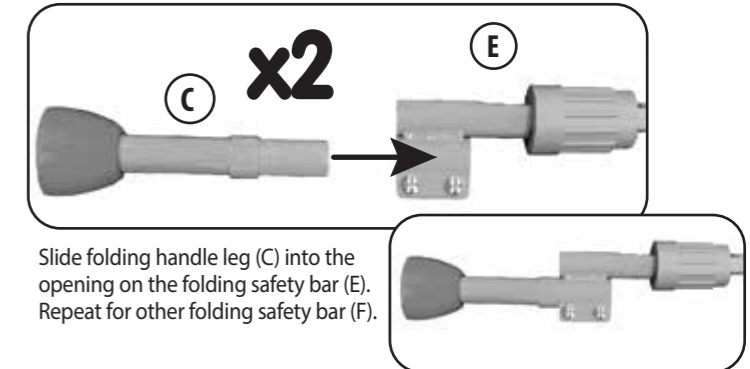

Slide folding handle leg (C) into the opening on the folding safety bar (E). Repeat for other folding safety bar (F).

NOTE: Wait to tighten the nuts on the folding safety bar until the legs are secured onto the trampoline railing.

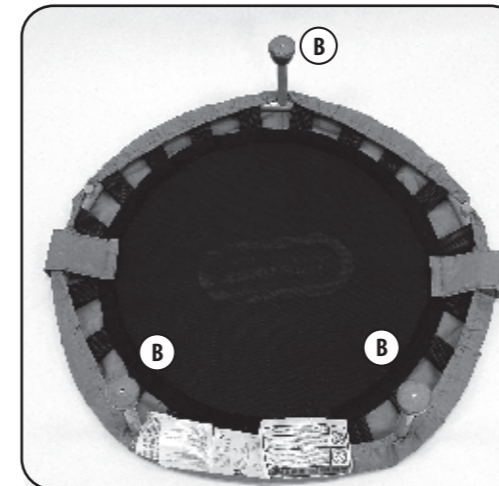

Insert (3) frame legs (B) and twist clockwise until completely tight. IMPORTANT: Be sure to assemble legs in correct location shown (Fig. 1).

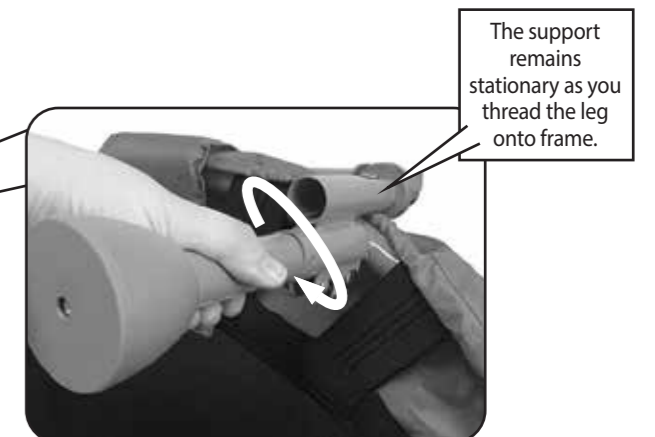
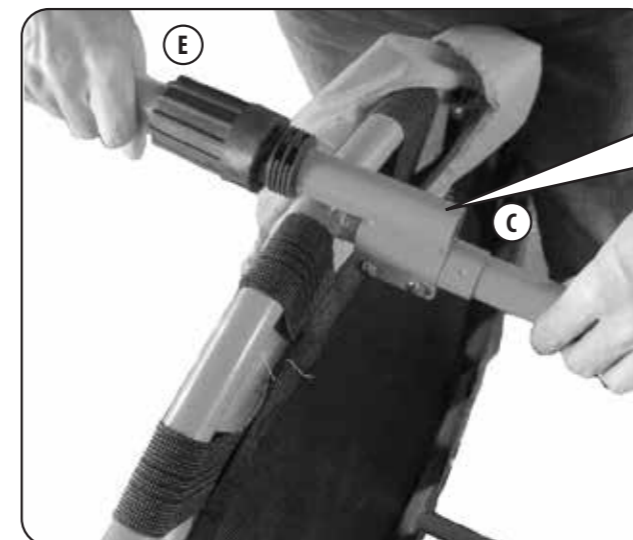
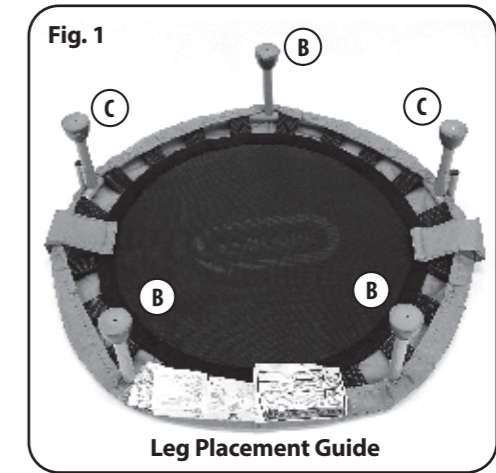

Twist assembled folding handle leg (C) onto frame until completely tight. Repeat for other side.

NOTE: These handle legs are located nearest to the velcro flaps.