

Go to www.tsicustomerservice.com for product warranty registration

ASSEMBLY INSTRUCTIONS

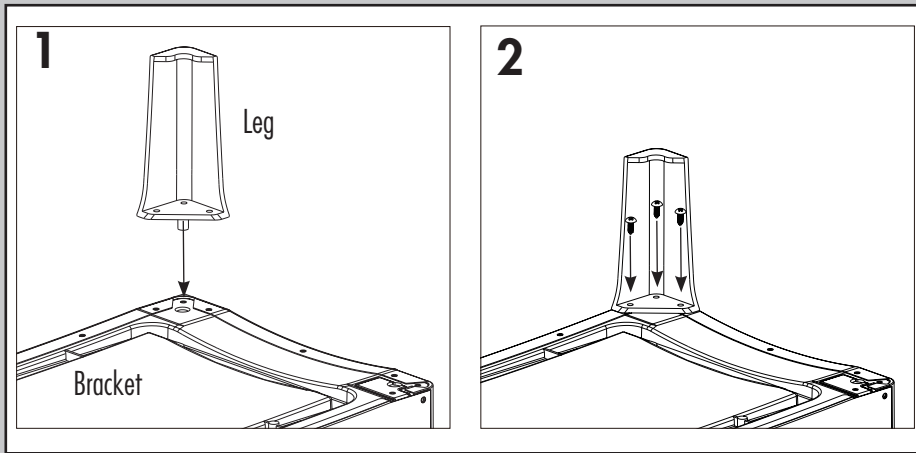

MOUNTING THE LEGS

1. Align the mounting tab into the bracket and lower the leg into place. (Fig 1)
2. Fasten the leg to the bracket using the included screws, 3 per leg.

OPERATING INSTRUCTIONS

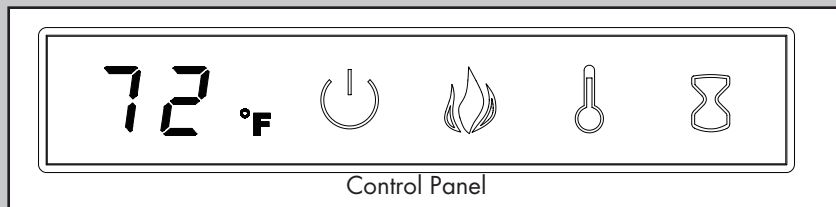
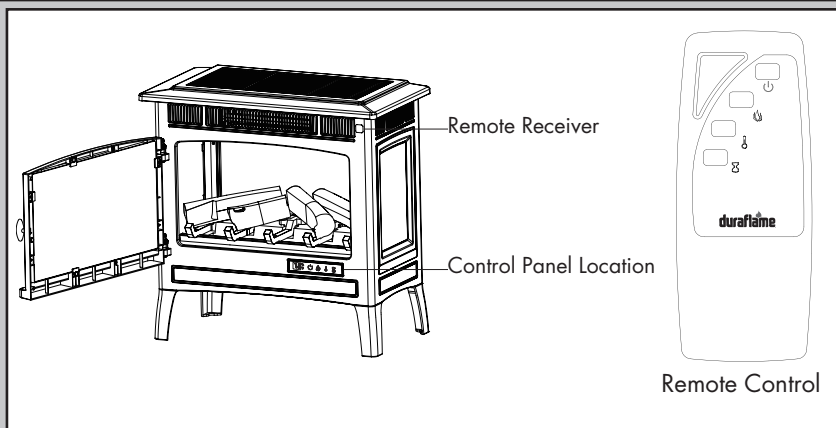

PRODUCT SPECIFICATIONS

VOLTAGE	120 VAC, 60 Hz
AMPS	12.5 Amps
WATTS	1500 Watts

Distributed by
Twin-Star International, Inc. Under license. **duraflame™** and the duraflame flame logo are trademarks of Duraflame, Inc.

Twin-Star International, Inc.
Delray Beach, FL 33445
Made in China • Printed in China

OPERATING INSTRUCTIONS

⏻ -- POWER

The POWER button supplies power to all the functions of the heater. Pressing the POWER button again the heater will be put in standby mode. This will turn off all functions at once but will hold the settings in the memory. By pressing the Power button again the unit will turn on at the same settings.

With the power on press and hold the Power button on the control panel for 10 seconds to disable or re-enable the heater function. Once disable or re-enabled the embered lights will flash multiple times.

🔥 -- FLAME

There are 5 brightness levels that can be selected and OFF (00) setting. Settings F5 - F1 decrease in brightness.

🌡️ -- HEATER

The stove contains a fan forced infrared element heater.

The thermostat setting range is 62°F - 82°F (17°C - 27°C) or continuously ON or OFF(00).

The thermostat is adjustable by 2°F or 1°C increments by pressing the HEATER button on the control panel.

To change between °F and °C press and hold the HEATER button on the control panel for 3 seconds.

The button on the remote only turns the heater on/off to the thermostat setting selected with the control panel.

⌚ -- TIMER

Pressing the timer button will cycle through the timer settings; 30 minutes, 1 Hour, 2H, 3H, 4H, 5H, 6H, 7H, 8H, 9H and off (00).

For Customer Service:

www.tsicustomerservice.com

(+1) 888-674-7517

8:30 a.m.-5:30 p.m., EST, Monday-Friday

Note: When first running the heater there can be an odor. This is normal, the heater has a surface coating on the internal parts, for the first several hours of operation the coating reacts with the internal parts to permanently protect them. The odor is safe; if you are sensitive to the odor it is recommended to run the heater in a well-ventilated area until the odor dissipates.

Warning: This is an unvented, electric appliance. DO NOT attempt to burn wood or manufactured firelogs in or on this appliance or grate.

Made in China
Printed in China

© 2015, Twin-Star International, Inc.

IMPORTANT INSTRUCTIONS

When using electrical appliances, basic precautions should always be followed to reduce the risk of fire, electrical shock, and injury to persons including the following:

1. Read all instructions before using this appliance.
2. This appliance is hot when in use. To avoid burns, do not let bare skin touch hot surfaces. If provided, use handles when moving this appliance. Keep combustible materials, such as furniture, pillows, bedding, papers, clothes and curtains at least 3 feet (0.9 m) from the front of this appliance and keep away from the sides and the rear.
WARNING: In order to avoid overheating, do not cover the heater.
3. **CAUTION:** Never leave the heater operating unattended. Extreme caution is necessary if unsupervised children or invalids are nearby.
4. The appliance is not to be used by children or persons with reduced physical, sensory or mental capabilities, or lack of experience and knowledge, unless they have been given supervision or instruction.
5. Always unplug this appliance when not in use.
6. Do not operate any heater with a damaged cord or plug or after the appliance malfunctions, or if it has been dropped or damaged in any manner.
7. If the supply cord is damaged, it must be replaced by the manufacturer, its service agent or similarly qualified persons in order to avoid a hazard.
8. Do not use outdoors.
9. This heater is not intended for use in bathrooms, laundry areas and similar indoor locations. Never locate this appliance where it may fall into a bathtub or other water container.
10. Do not run cord under carpeting. Do not cover cord with throw rugs, runners or the like. Arrange cord away from traffic areas and where it will not be tripped over.
11. To disconnect this appliance, turn controls to the off position, then remove plug from outlet.
12. Connect to properly grounded outlets only. This heater is for use on 120 volts. The cord has a plug as shown at A in Fig.1. Do not use a 2 prong adapters. Never use with an extension cord or relocatable power tap (outlet/power strip).

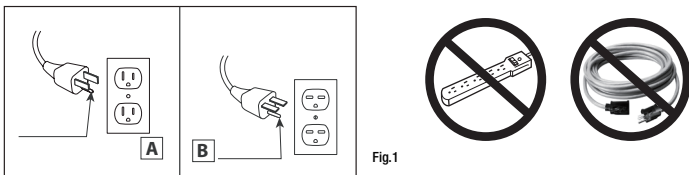

Fig.1

13. This appliance, when installed, must be electrically grounded in accordance with local codes or, in the absence of local codes, with the current CSA C22.1 Canadian Electrical Code or for U.S.A. installations, follow local codes and the National Electrical Code, ANSI/NFPA NO.70.
14. Do not insert or allow foreign objects to enter any ventilation or exhaust opening as this may cause an electric shock or fire, or damage the appliance.
15. To prevent a possible fire, do not block air intakes or exhaust in any manner. Do not use on soft surfaces, like a bed, where opening may become blocked.

1-YEAR LIMITED WARRANTY

The manufacturer warrants that your new Electric Stove is free from manufacturing and material defects for a period of one year from date of purchase, subject to the following conditions and limitations.

1. Install and operate this Electric Stove in accordance with the installation and operating instructions furnished with the product at all times. Any unauthorized repair, alteration, willful abuse, accident, or misuse of the product shall nullify this warranty.
2. This warranty is non-transferable, and is made to the original owner, provided that the purchase was made through an authorized supplier of the product.
3. The warranty is limited to the repair or replacement of part(s) found to be defective in material or workmanship, provided that such part(s) have been subjected to normal conditions of use and service, after said defect is confirmed by the manufacturer's inspection.
4. The manufacturer may, at its discretion, fully discharge all obligations with respect to this warranty by refunding the wholesale price of the defective part(s).
5. Any installation, labor, construction, transportation, or other related costs/expenses arising from defective part(s), repair, replacement, or otherwise of same, will not be covered by this warranty, nor shall the manufacturer assume responsibility for same.
6. The owner/user assumes all other risks, if any, including the risk of any direct, indirect or consequential loss or damage arising out of the use, or inability to use the product, except as provided by law.
7. All other warranties – expressed or implied –with respect to the product, its components and accessories, or any obligations/liabilities on the part of the manufacturer are hereby expressly excluded.
8. The manufacturer neither assumes, nor authorizes any third party to assume on its behalf, any other liabilities with respect to the sale of the product.
9. The warranties as outlined within this document do not apply to non accessories used in conjunction with the installation of this product.
10. This warranty gives you specific legal rights, and you may also have other rights which vary from state to state.

This warranty is void if:

- a. The fireplace is subjected to prolonged periods of dampness or condensation.
- b. Any unauthorized alteration, willful abuse, accident, or misuse of the product.
- c. You do not have the original receipt of purchase.

IF WARRANTY SERVICE IS NEEDED

Contact the manufacturer by calling customer service department at 1-888-674-7517, 7 days a week 24 hours a day at our toll-free help line. Our Consumer Service department is available Monday – Friday 8:30 am – 5:30 pm EST. Make sure you have your warranty, your sales receipt, location of purchase and the model/serial number of your product.

16. This appliance has hot and arcing or sparking parts inside. Do not use it in areas where gasoline, paint or flammable liquids are used or stored. This fireplace should not be used as a drying rack for clothing. Christmas stockings or decorations should not be hung in the area of it.
17. Use this appliance only as described in the manual. Any other use not recommended by the manufacturer may cause fire, electric shock or injury to persons.
18. This heater may include a visual alarm to warn that parts of the heater are getting excessively hot. If the alarm flashes immediately turn the heater off and inspect for any objects on or adjacent to the heater that may cause high temperatures.

DO NOT OPERATE THE HEATER WITH THE ALARM FLASHING!

Battery Replacement

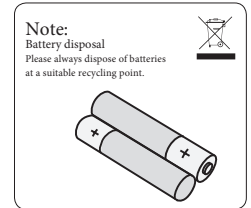
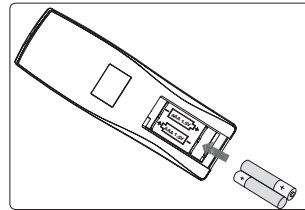

1. The battery compartment is located on the back end of the remote control.
2. Press and slide the battery door open and remove the old battery.
3. Insert 2 AAA batteries, checking that the + and - sides of the battery match inside the battery compartment.
4. Replace the battery compartment door.

Caution:

For best results, use 2pcs AAA alkaline batteries.

Install only new batteries of the same type in your product.

Failure to insert batteries in the correct polarity, as indicated in the battery compartment, may shorten the life of the batteries or cause batteries to leak. Do not mix old and new batteries.

Do not mix Alkaline, Standard (Carbon-Zinc) or Rechargeable (Nickel Cadmium) or (Nickel Metal Hydride) batteries.

Danger of explosion if battery is incorrectly replaced.

Do not ingest batteries.

Non-rechargeable batteries are not to be recharged.

Exhausted batteries are to be removed from the product.

Batteries should be recycled or disposed of as per state and local guidelines.

DISPOSAL OF USED BATTERIES

Battery may contain hazardous substances which could endanger the environment and human health. Used batteries shall not be treated as municipal waste, but left at the appropriate collection point for recycling.

For more information about collection and recycling of used batteries, please contact your local municipality or waste disposal service.

SAVE THESE INSTRUCTIONS

TROUBLESHOOTING GUIDE

Problem	Root Cause	Corrective Action
1. Display shows " E 1 "	1. The thermostat sensor is broken or disconnected.	1. Unplug the fireplace, remove the back panel of the fireplace and check that the thermostat is plugged into the main circuit board. If this does not solve the problem contact customer service for a replacement thermostat sensor.
2. Display shows " E 2 "	2. The thermostat sensor is broken.	2. Contact customer service for a replacement thermostat sensor.
3. Display shows " E 3 "	3. Manual Reset overheat protection has triggered.	3. Inspect the heater and check that the air inlets and outlets are not blocked as this may cause overheating. Unplug the heater for 30 minutes and allow it to cool down. Replug and operate, monitor the heater for signs of overheating, if the problem persist discontinue use of the heater and contact customer service.
4. Display shows " E r "	4. Power cord overheating protection has activated.	4. Check your heater cord and plug connections. Faulty wall outlet connections or loose plugs can cause the outlet or plug to overheat. Be sure the plug fits tight in the outlet. Heaters draw more current than small appliances, overheating of the outlet may occur even if it has not occurred with the use of other appliances. During use check frequently to determine if your plug outlet or faceplate is HOT! If so, discontinue use of the heater and have a qualified electrician check and/or replace the faulty outlet(s).
5. No power, buttons do not light up.	5. Power cord was not plugged into the outlet.	5. Check that unit is plugged directly into a standard 120 volt outlet.
6. Stove does not turn on manually.	6a. No incoming power from the electrical wall socket or buttons. 6b. Improper operation. 6c. Defective button	6a. Check circuit breakers and move unit to another outlet. 6b. Manually press main power button from front of unit. 6c. Replace control panel circuit board.
7. Flames are not moving.	7a. Defective flame generator drive motor. 7b. Spinner detached from the motor.	7a. Replace flame generator drive motor. 7b. Remove the back panel/ emberbed/ metal bracket and check to see if "spinner" is correctly mounted to the motor.
8. Logs glow, but no flame effect.	8. Flame effect turned off	8. Press flame button several times.
9. Heater does not blow warm air.	9. Thermostat setting is preventing heater from turning on.	9. Adjust the temperature settings to ensure that the thermostat is set higher than the current room temperature.
10. Heater is not turning on.	10a. Improper operation 10b. Defective heater/blower assembly.	10a. Manually press main power button on front of unit. 10b. Replace heater/blower assembly.
11. Not producing enough heat.	11a. power strip/surge protector/ extension cord being used 11b. Location of unit.	11a. Plug unit directly into the wall. 11b. Make sure unit is located on an interior wall.
12. Unit blows cool or cold air.	12. Defective heater blower assembly.	12. Replace heater blower assembly.
13. Noise with heater on.	13a. Dirty heater blower motor 13b. Defective heater/blower assembly.	13a. Gently vacuum heater blower vents. 13b. Replace heater/blower assembly.
14. Noise with flames on and heater off.	14a. Defective flame generator drive motor. 14b. Dented back panel 14c. Warped spinner shaft	14a. Replace flame generator drive motor. 14b. Refer to TSI customer service. 14c. Refer to TSI customer service.
15. Is it safe to place unit on carpet?	15. Product Inquiry	15. It is safe to place unit on carpet but make sure any flammable items are at least 3 feet away from front and sides of the unit.
16. How many square feet will my unit warm up?	16. Product Inquiry	16. Provides supplemental heat up to 1000 square feet
17. Flame effect works but heater function does not and the emberbed flashes when the heater button is pressed.	17. The heater is disabled.	17. With the power on press and hold the POWER button on the control panel for 10 seconds. Once re-enabled the emberbed lights will flash multiple times.
18. Remote control is not working when buttons are pressed.	18a. No batteries or battery power. 18b. Poor signal 18c. Distance	18a. Change the remote batteries. 18b. Operate remote transmitter at a slow measured pace. Press the remote control buttons with an even motion and gentle pressure. Repeatedly pressing buttons in rapid succession may cause the transmitter to malfunction. 18c. Operate the remote at a distance less than 20 feet from the front of the appliance; point the remote at the control panel.

EXPLODED VIEW

Part	Part Name	Part Number
1	Main Circuit Board	Y16-S174-P15
2	Flame Generator Drive Motor	Y16-S174-P10
3	Door Pull	Y16-S201-DP
4	Control Panel Circuit Board	Y16-S174-P32
5	Heater/Blower Assembly	Y15-S201-P01
6	Stove legs	SL-5010-BLK
7	Remote control	P136
8	Thermostat Sensor	NTC-S

