

Multi-functional Timer relay.

User Manual

V5.0

12/26/2017

Table of Contents

1. Multifunctional Timer Relay description	3
2. Timer wiring diagram	4
2.1 Connecting 5amp timer	4
2.2 Connecting 10amp positive output timer	4
2.3 Connecting 10amp negative (sink) output timer	5
3. Understanding Timer Delay Relay Function.....	5
4. Timer function table with charts.....	6
5. Timer trigger.	16
5.1 Timer trigger operation with charts.....	16
5.2 Example of trigger setup.	17
5.3 Timer trigger configuration table.....	18
6. Timer Output mode	18
7. Timer Output type	19
8. Time programming modes.....	19
9. Timer installation and programming.	20
10. Reseting Timer to the factory settings.....	22
11. Timer application examples	23
11.1 Extend current capacity be adding external relay.....	23
11.2 Extend current capacity be adding external relay.....	23
11.3 Use button to create self latching timer	24
11.4 Use button to create self latching timer with ability to turn off	25
11.5 Delay Off timer with 0 power consumption in Off state	26
12. 10 amp Timer	27
13. 10 amp Timer with LCD.....	28
14. Accessories.....	29
14.1 Timer configuration button board	29
15. YouTube Videos	30

1. Multifunctional Timer Relay description

Multifunctional Timer delay module is a revolutionary circuit with many commonly used timer delay functions. It is perfect for many applications from hobby to industrial controls. The **timer** has more than twenty different timing functions with optional ability to trigger them by application of input voltage to the trigger wire or opening/closing dry contacts. The **timer** can be used for hundreds of various applications from delaying power to the circuit, supplying power in cycling fashion or creating self-latching timed circuit. The **timer** is easy to connect and configure. All the configurations are permanently saved into the internal flash memory. The **timer** works with 5V to 20V supply voltage and can handle up to 5amp/10amp of current. This make makes it applicable to the variety of applications. Maximum current can be extended with the use of the external relay.

Voltage range:	5v-20v
Max current:	5amp or 10amp
Minimum time duration:	0.1 second
Maximum time duration:	400 days
Timer current consumption:	0.004amp

2. Timer wiring diagram

2.1 Connecting 5amp timer

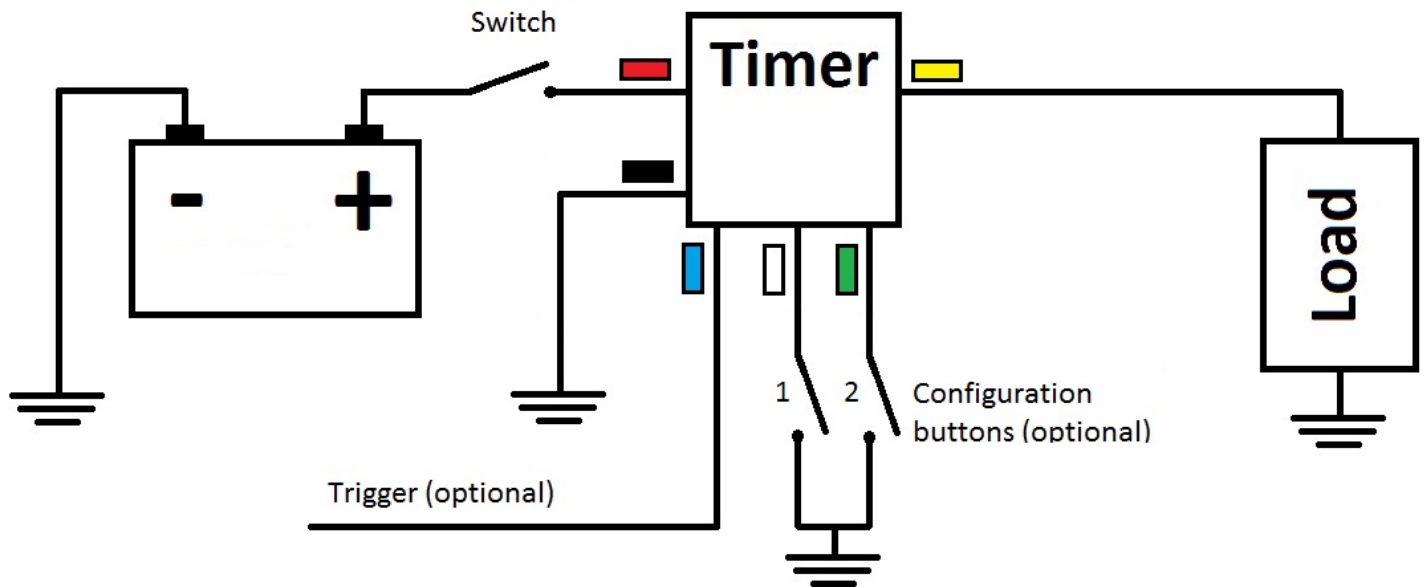

2.2 Connecting 10amp positive output timer

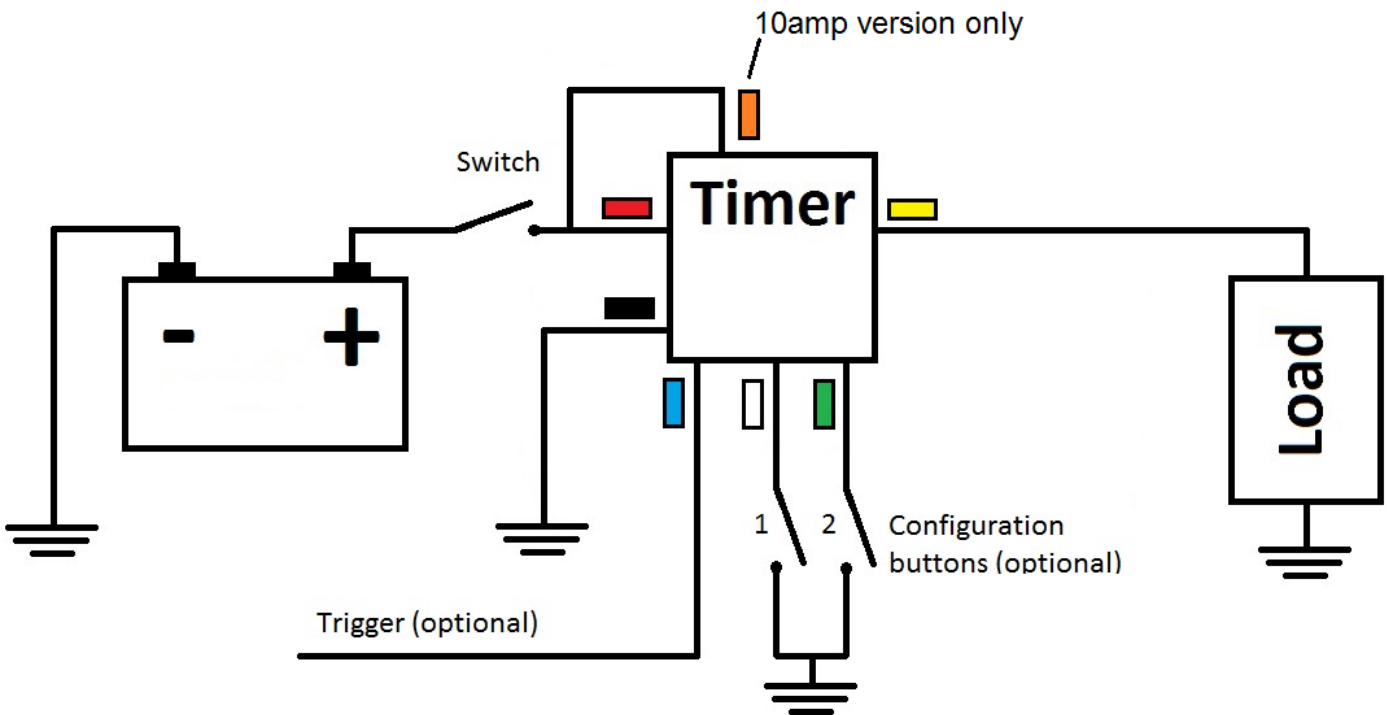

*** For up to date installation instructions and videos visit www.bit.ly/timer20
View Timer's Cook Book at: http://timers.shop/Timer-Cook-Book_ep_43-1.html

2.3 Connecting 10amp negative (sink) output timer

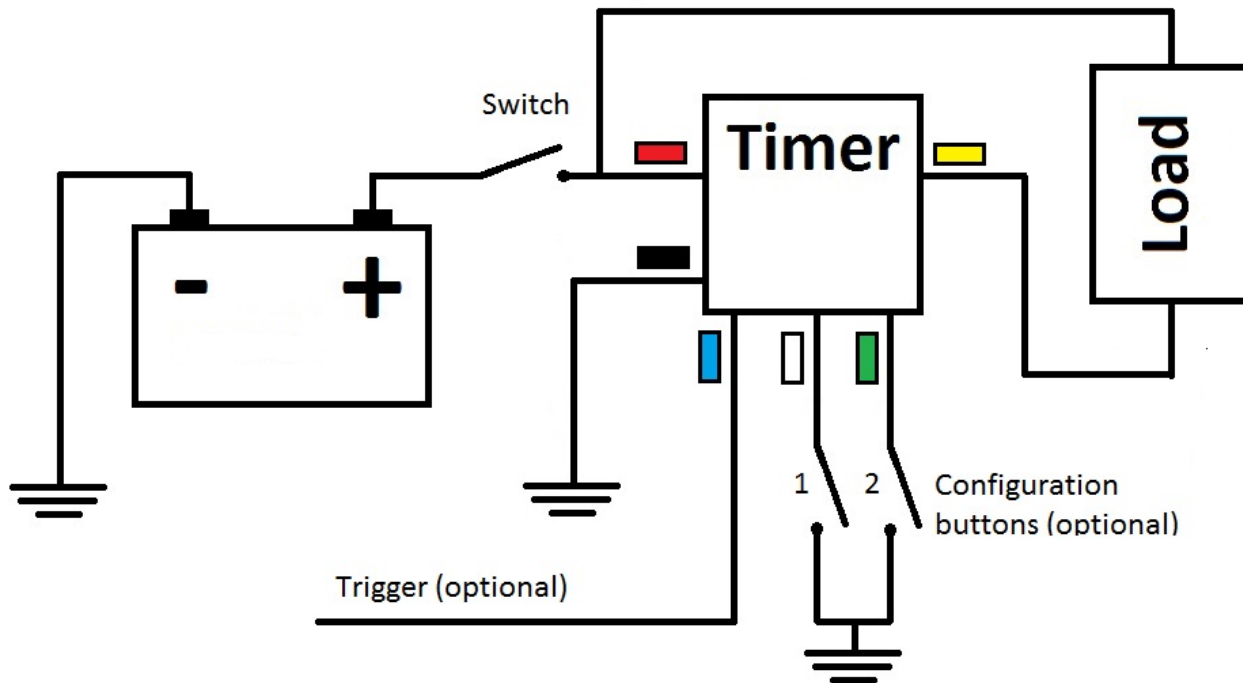

3. Understanding Timer Delay Relay Function.

Understanding all the time delay relay functions available in multifunctional timer can be an intimidating task. During the circuit design with the timer relay and variety of timer configuration, questions such what initiates the timer delay functions, does the timing starts with the application of the power or trigger signal, for how long output power should stay on, etc., could arise and must be answered.

The timer is simply a logic control circuit with the purpose of controlling the output power based on the events. Typically, timer initiated or triggered by one of two methods:

- Application of power voltage
- High or low trigger signal

The trigger signal can be one of the following:

- A control switch (dry contacts): limit switch, push button, float switch
- Voltage (power trigger): signal output from another device, power signal

To help understand the timer functionality let's look at common terminology used throughout this manual.

- **Input Voltage** – power voltage applied to the timer. Depending on selected function, input voltage will either initiate the timing event or power the timer to be ready to accept the trigger signal.
- **Trigger Signal** – in certain timing functions, a trigger is used to initiate timing event after input voltage has been applied. As noted above this trigger can either be a control switch (dry contact switch) or a power trigger (voltage).
- **Output** – output voltage from the timer. Timing of the output voltage is controlled by the selected timing event and trigger method.

Below (**Figure 1**) is a description of timing functions. A timing chart shows the relationship between Input Voltage, Trigger Signal and Output. Note that Trigger Signal is optional for some of the timer functions and mandatory for others. Before going through all the available functions look at the first one in details.

Figure 1.

#	Function	Operation	Timing chart
1	ON DELAY	Upon application of input voltage, the time relay (t) begins. At the end of the time delay (t), the output is energized. Input voltage must be removed to reset the time delay relay & de-energize the output.	

The timer function #1 is **ON DELAY**, it allows to supply power after a period of time (t). There are two timing charts, one without a trigger and one with the trigger. Trigger selection can be done during timer configuration. Let's look at the first chart where the timer is triggered by the supplied input voltage. Once power is supplied to the timer, time delay (t) begins, at the end of the time delay (t) output is energized and stays on until power to the timer is removed. Removal of the power resets the timer circuit and the timer is ready for another cycle. The second chart is applicable when trigger option is selected. In this particular case, trigger on High (positive) voltage is selected. More on trigger options can be found later in the manual. Upon application of power, the timer is ready to accept the trigger signal. When trigger is applied, time delay (t) begins. At the end of the time delay (t) output is energized and stays on until power to the timer is removed. Another application of the trigger during time delay (t) or during the output energized period, has no effect on the timer function. Only the first application of the trigger matters.

4. Timer function table with charts

(Note that function number # will be used during timer configuration.)

Figure 2.

#	Function	Operation	Timing chart
1	ON DELAY	Upon application of input voltage, the time delay (t) begins. At the end of the time delay (t), the output is energized. Input voltage must be removed to reset the time delay relay and de-energize the output.	

#	Function	Operation	Timing chart
2	INTERVAL ON	Upon application of input voltage, the output is energized and the time delay (t) begins. At the end of the time delay (t), the output is de-energized. Input voltage must be removed to reset time delay relay.	
3	FLASHER (On First)	Upon application of voltage, the output is energized and the time delay (t) begins. At the end of the time delay (t), the output is de-energized and remains in that condition for the time delay (t). At the end of the time delay (t), the output is energized and the sequence repeats until input voltage is removed.	
4	FLASHER (Off First)	Upon application of input voltage, the time delay (t) begins. At the end of the time delay (t), the output is energized and remains in that condition for the time delay (t). At the end of the time delay (t), the output is de-energized and the sequence repeats until input voltage is removed.	
5	REPEAT CYCLE (On 1st)	Upon application of input voltage, the output is energized and the time delay (t1) begins. At the end of the time delay (t1), the output is de-energized and remains in that condition for the time delay (t2). At the end of this time delay, the output is energized and the sequence repeats until input voltage is removed.	

#	Function	Operation	Timing chart
6	REPEAT CYCLE (Off 1 st)	Upon application of input voltage, the time delay (t1) begins. At the end of the time delay (t1) the output is energized and remains in that condition for the time delay (t2). At the end of this time delay, the output is de-energized and the sequence repeats until input voltage is removed.	
7	DELAYED INTERVAL Single Cycle	Upon application of input voltage, the time delay (t) begins. At the end of the time delay (t1), the output is energized and remains in that condition for the time delay (t2). At the end of this time delay (t2), the output is de-energized. Input voltage must be removed to reset the time delay relay.	
8	TIMED FLASHER (On First)	Upon application of voltage, time delay (t2) begins and the output is energized for the time delay (t1). At the end of the time delay (t1), the output is de-energized and remains in that condition for the time delay (t1). At the end of the time delay (t1), the output is energized and the sequence repeats until time delay (t2) is completed.	
9	TIMED FLASHER (Off First)	Upon application of voltage, time delay (t2) begins and initial time delay (t1) starts. At the end of the time delay (t1), the output is energized and remains in that condition for the time delay (t1). At the end of the time delay (t1), the output is de-energized and the sequence repeats until time delay (t2) is completed.	

#	Function	Operation	Timing chart
10	ON/OFF DELAY	Upon application of input voltage, the time delay relay is ready to accept a trigger. When the trigger is applied, the time delay (t1) begins. At the end of the time delay (t1), the output is energized. When the trigger is removed, the output remains energized for the time delay (t2). At the end of the time delay (t2), the output is de-energized and the time delay relay is ready to accept another trigger. If the trigger is removed during time delay period (t1), the output will remain de-energized and the time delay (t1) will reset. If the trigger is re-applied during time delay period (t2), the output will remain energized and the time delay (t2) will reset.	
11	TRIGGERED ON DELAY	Upon application of input voltage, the time delay relay is ready to accept a trigger. When the trigger is applied, the time delay (t) begins. At the end of the time delay (t), the output is energized and remains in that condition as long as either the trigger is applied or the input voltage remains. If the trigger is removed during the time delay (t), the output remains de-energized and the time delay (t) is reset.	

#	Function	Operation	Timing chart
12	OFF DELAY	Upon application of input voltage, the time delay relay is ready to accept a trigger. When the trigger is applied, the output is energized. Upon removal of the trigger, the time delay (t) begins. At the end of the time delay (t), the output is de-energized. Any application of the trigger during the time delay will reset the time delay (t) and the output remains energized.	
13	SINGLE SHOT TIME RESET	Upon application of input voltage, the time delay relay is ready to accept a trigger. When trigger is applied, the output is energized and timer delay (t) begins. Any application of the trigger during the time delay will reset the time delay (t) and the output remains energized.	
14	SINGLE SHOT	Upon application of input voltage, the time delay relay is ready to accept a trigger. When the trigger is applied, the output is energized and the time delay (t) begins. During the time delay (t), the trigger is ignored. At the end of the time delay (t), the output is de-energized and the time delay is ready to accept another trigger.	

#	Function	Operation	Timing chart
15	TRIGGERED DELAY INTERVAL Single Cycle	Upon application of input voltage, the time delay relay is ready to accept the trigger. When the trigger is applied, the time delay (t1) begins. At the end of the time delay (t1), the output is energized and remains in that condition for the time delay (t2). At the end of the time delay (t2), the output is de-energized and the relay is ready to accept another trigger. During both time delay (t1) and time delay (t2), the trigger is ignored.	
16	INTERVAL ON WITH OFF TRIGGER	Upon application of input voltage, the time delay relay is ready to accept the trigger. When trigger is applied, the output is energized and the time delay (t) begins. At the end of the time delay (t), the output is de-energized. Application of trigger during time delay (t) will cause time delay (t) to expire and output is de-energized.	
17	INTERVAL ON TRIGGER CONTROLLED	Upon application of input voltage, the time delay relay is ready to accept the trigger. When trigger is applied, the output is energized and the time delay (t) begins. At the end of the time delay (t), the output is de-energized. Removal of the trigger during time delay (t) will cause time delay (t) to expire and output is de-energized.	

#	Function	Operation	Timing chart
18	FREE FORM ONE TIME (Upto 100 configuration points)	Upon application of voltage, time delay begins and free form pattern programmed by the user is executed. When pattern is completed it can be retriggered again.	
19	FREE FORM REPEATED (Upto 100 configuration points)	Upon application of voltage, time delay begins and free pattern cycle programmed by the user is executed. Once started the cycle will be repeated over and over.	
20	CANCELLED INTERVAL	Upon application of input voltage, the output is energized and the time delay (t) begins. At the end of the time delay (t), the output is de-energized. If trigger is applied during the time delay (t) the output is de-energized and delay cancelled. Input voltage must be removed to reset time delay relay.	
21	SINGLE SHOT TIME RESET HOLD ON TRIGGER	Upon application of input voltage, the time delay relay is ready to accept a trigger. When trigger is applied, the output is energized and timer delay (t) begins. Any application of the trigger during the time delay will reset the time delay (t) and the output remains energized. If trigger still applied after the delay (t) the output remains energized until trigger is removed.	

#	Function	Operation	Timing chart
22	FOLLOW	Upon application of input voltage, the time delay relay is ready to accept a trigger. When trigger is applied, the output is energized and continued to be energized until the trigger is removed. When trigger is removed the output is de-energized.	
23	BUTTON INTERFACE WITH TIMEOUT	Upon application of input voltage the timer delay relay is ready to accept trigger input. With short (< 1sec) application of trigger the output is energized for the time delay (t). The second application of trigger will de-energize the output. With long (>1sec) application of trigger the output is energized and held energized until the trigger is removed.	
24	BUTTON INTERFACE	Upon application of input voltage the timer delay relay is ready to accept trigger input. With short (<1sec) application of trigger the output is energized. The second application of trigger will de-energize the output. With long (>1sec) application of trigger the output is energized and held energized until the trigger is removed.	
25	OUTPUT ON TRIGGER CHANGE	Upon application of input voltage the timer delay relay is ready to accept trigger input. When trigger is applied the output is energized for time delay (t1). The release of the trigger is also energizes the output for time (t2)	

#	Function	Operation	Timing chart
26	BUTTON INTERFACE WITH TIMEOUT	Upon application of input voltage the timer delay relay is ready to accept trigger input. With short ($<t_2$) application of trigger the output is energized for the time delay (t_1). The second application of trigger will de-energize the output. With long ($>t_2$) application of trigger the output is energized and held energized until the trigger is removed.	
27	BUTTON INTERFACE	Upon application of input voltage the timer delay relay is ready to accept trigger input. With short ($<t_2$) application of trigger the output is energized. The second application of trigger will de-energize the output. With long ($>t_2$) application of trigger the output is energized and held energized until the trigger is removed.	
28	FUNCTION 28	Upon application of input voltage the timer delay relay is ready to accept trigger input. With short ($<t_2$) application of trigger the output is energized for the time delay (t_1). The second application of trigger will reset delay (t_1). With long ($>t_2$) application of trigger the output is energized and held energized until the trigger is removed. With long ($>t_2$) application of trigger during the active output t_1 timeout is cancelled and output stays energized until trigger is removed.	

#	Function	Operation	Timing chart
29	INTERVAL WITH LOCKOUT Single Cycle	Upon application of input voltage, the time delay relay is ready to accept the trigger. When the trigger is applied the output is energized and the time delay (t1) begins. At the end of the time delay (t1), the output is de-energized and remains in that condition for the time delay (t2). During both time delay (t1) and time delay (t2), the trigger is ignored.	<p>The timing chart illustrates the relay's behavior. The top row, 'Input Voltage', is a solid red bar. The middle row, 'Trigger', shows blue pulses: a short pulse during the first t1 interval, a short pulse during the t2 interval, and a long pulse starting after the second t2 interval. The bottom row, 'Output', shows yellow blocks for energized periods: one during the first t1 interval and another during the second t1 interval. White blocks represent de-energized periods, occurring during both t2 intervals.</p>
		If none of the above patterns meet your requirements please contact us as we might be able to include it in the next software revision.	

5. Timer trigger.

As described above timer initiated or triggered by one of two methods:

- Application of power voltage
- High or low trigger signal

Trigger signal can be one of the following:

- A control switch (dry contacts): limit switch, push button, float switch
- Voltage (power trigger): signal output from another device, power signal

5.1 Timer trigger operation with charts.

Figure 3.

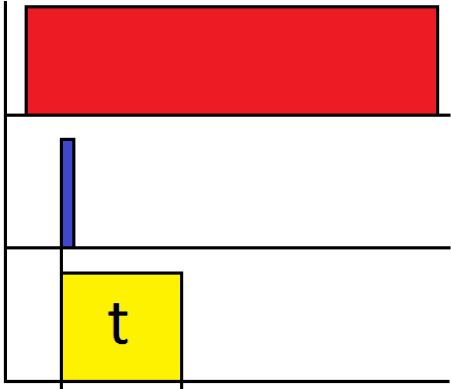
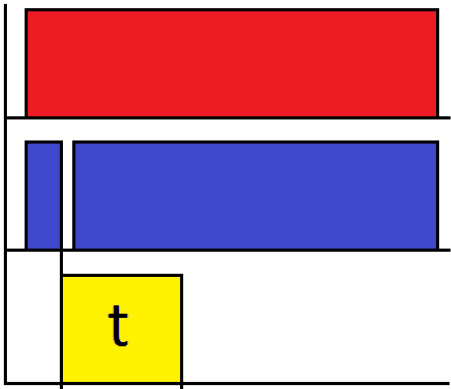
<p>High trigger</p>	<p>Upon application of power the time delay relay is ready to accept the trigger. Transition of the voltage on trigger wire from low* to high** will trigger start of the time delay (t).</p>	
<p>Low trigger</p>	<p>Upon application of power the time delay relay is ready to accept the trigger. Transition of the voltage on trigger wire from high** to low* will trigger start of the time delay (t).</p>	

Low** trigger voltage is considered to be less than $< 0.5v$ and should be as close to $0v$ as possible. *High** trigger voltage is greater than $> 0.8v$ and could be as high as input voltage.

To use trigger input with dry contact (like switch or button), trigger wire would need to be ‘pulled’ to either High or Low voltage. Timer configuration allows for trigger wire to be set to either be pulled to High, where a small current is applied to keep the wire at High voltage or grounded keeping the trigger wire at Low voltage. The following table demonstrates when to configure trigger wire pull to High or to Low.

5.2 Example of trigger setup.

Figure 4.

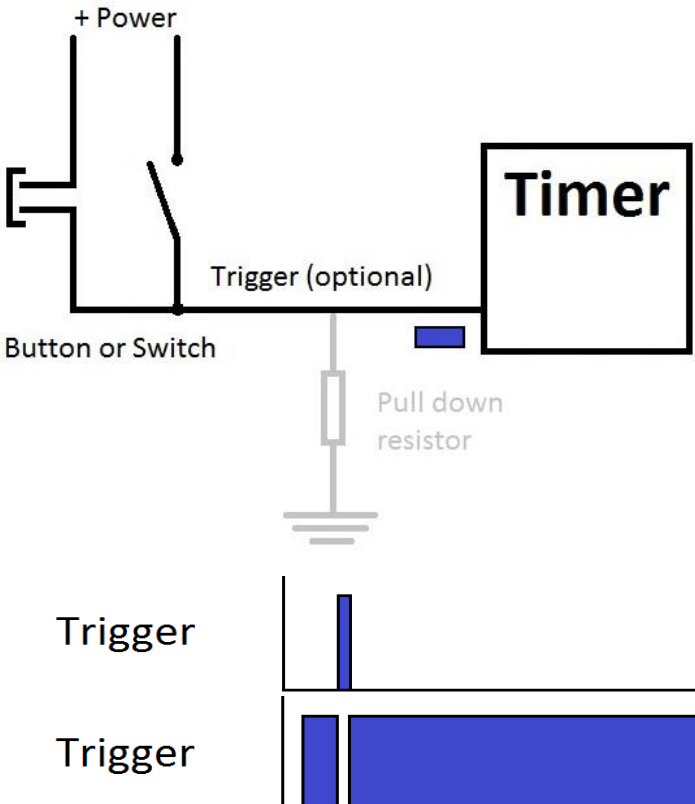
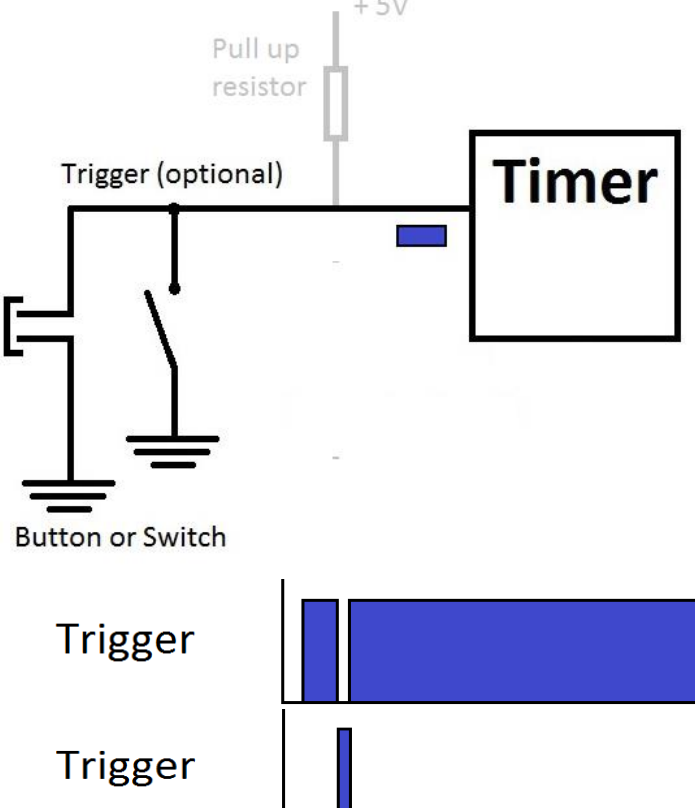
Trigger pull configuration	Description	Wiring diagram and trigger chart
<p>Trigger pulled to Low</p>	<p>Trigger is set to be pulled to Low, so with button or switch disengaged time delay relay reading Low on the trigger wire. Upon button or switch engagement trigger voltage jumps to High.</p> <p>Trigger could also be a positive voltage applied to the trigger wire.</p> <p>Note: event could be triggered with High signal by engaging button or switch OR with Low signal by disengaging button or switch. See two trigger charts.</p> <p>Shown Pull down resistor is built into the timer and does not need to be connected externally.</p>	 <p>The diagram shows a button or switch connected to + Power and a pull-down resistor connected to ground. The timer's trigger input is connected to the switch. The trigger chart shows a low-level signal with a sharp high pulse when the button is pressed.</p>
<p>Trigger pulled to High (preferred)</p>	<p>Trigger is set to be pulled to High so with button or switch disengaged time delay relay reading High on the trigger wire. Upon button or switch engagement trigger voltage jumps to Low (grounded).</p> <p>Trigger could also be Low voltage applied to the trigger wire.</p> <p>Note: event could be triggered with Low signal by engaging button or switch OR with High signal by disengaging button or switch. See two trigger charts.</p> <p>Shown Pull up resistor is built into the timer and does not need to be connected externally.</p>	 <p>The diagram shows a button or switch connected to ground and a pull-up resistor connected to +5V. The timer's trigger input is connected to the switch. The trigger chart shows a high-level signal with a sharp low pulse when the button is pressed.</p>

5.3 Timer trigger configuration table.

(Note that timer trigger function number # will be used during timer configuration.)

Figure 5.

#	Trigger will pull	Active Trigger	Description
1	Low	No trigger	Trigger is disabled
2 (6)	Low	High	For dry contacts where button or switch is connected between trigger wire and positive.
3 (7)	Low	Low	For signal trigger where the signal can pull trigger wire to inactive High state.
4 (8)	High (preferred)	Low	For dry contacts where button or switch is connected between trigger wire and ground.
5 (9)	High	High	For signal trigger where the signal can pull trigger wire to inactive Low state.

(6),(7),(8),(9) Trigger functions insure the trigger transition from inactive to activate state upon startup.

6. Timer Output mode

Timer output mode allows the user to set either instant output, where the output come on and goes off instantly, or gradual increase/decrease, where the output is PWM (Pulse Width Modulation) controlled and ramps up to 100% duty in about 4 seconds. The gradual output is great for lighting system to gradually increase and dim the lights.

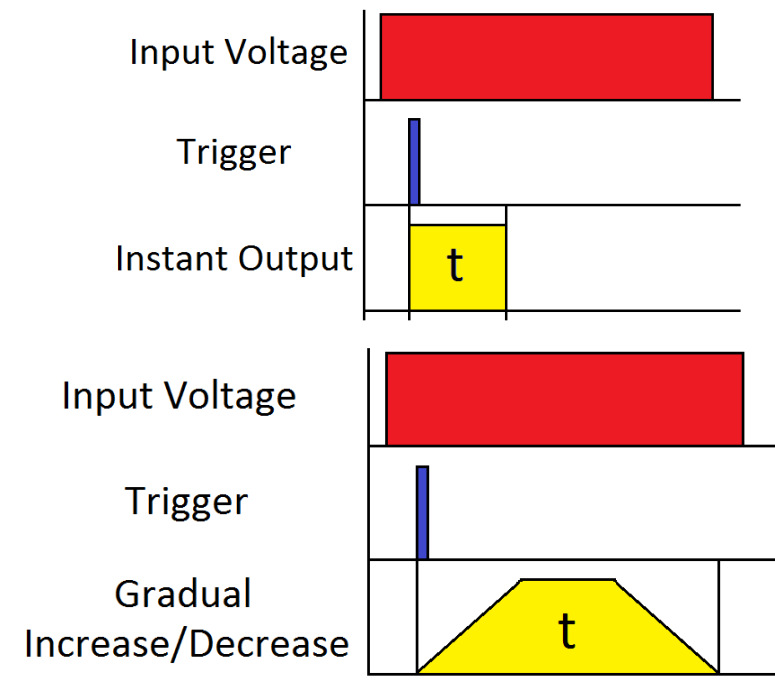

Timer is preconfigured with instant output. To change output mode please follow below programming steps.

7. Timer Output type

In some circumstance it is required to supply reversed output to the load, so instead of supplying power to the load during the time delay (t) the output is de-energized.

The following diagram shows sample timer operation with normal and reversed output.

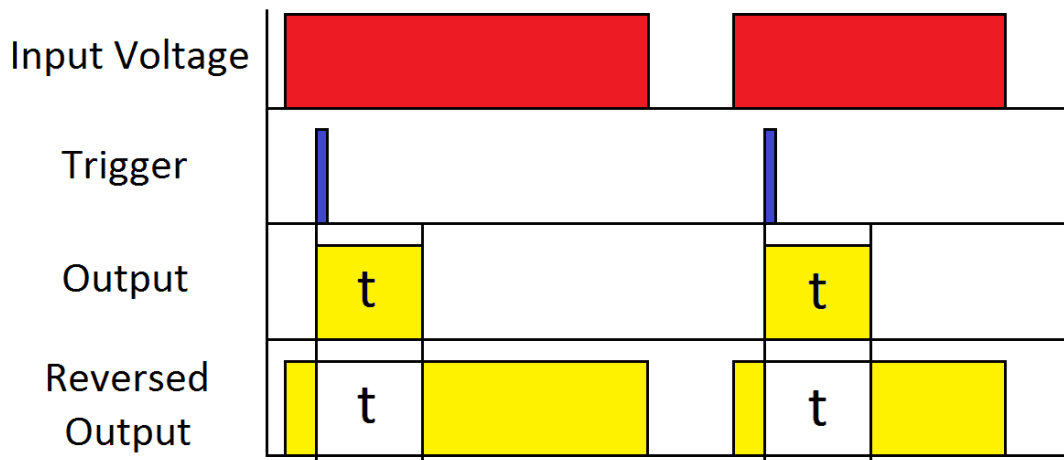

Timer is preconfigured with normal output. To reverse output please follow below programming steps.

8. Time programming modes.

Time duration can either be programmed in normal (duration) mode or hours/minutes/seconds. In the normal mode timer you will be programming time by grounding one of the configuration wires for exact interval you want the timer to repeat. Timer learns for how long the wire was grounded and stores the duration in the internal memory. This mode is great for short and medium durations. For longer duration the timer can be switched to the hours/minutes/seconds mode where the time is set by setting hours, minutes and second. Time is set by configuring the following six parameters:

1/30 Seconds	Seconds	Minutes	Minutes x 10	Hours	Hours x 10	Hours x 100	Hours x 1000
--------------	---------	---------	--------------	-------	------------	-------------	--------------

Watch the [YouTube video](#) on how to set the timer in hours/minutes/seconds mode.

To use the HMS mode you first need to set TIME PROGRAMMING MODE to use HMS mode, then turn off the timer and restart the programming. During the next programming cycle you would use configuration wire to set the time in hours/minutes/seconds. First go into programming mode, then use the white wire and touch the ground wire the number of times equal to the number of 1/30 seconds you need. For example touch the white wire to ground ten times if you want to set seconds to 1/3 sec. Then touch the white wire to the ground again and hold until you see output rapidly cycles multiple times. It confirms saving of the 1/30 seconds and goes to the next parameter which is seconds, set amount of seconds in the same fashion and again hold the wire to the ground to confirm. Continue to other parameters shown in the table above. Once the time is set continue with normal programming sequence shown below.

9. Timer installation and programming.

General programming consists of:

- Go into programming mode by grounding two configuration wires (WHITE/GREEN) and supplying power to the Timer.
- Configure timer delay t1 and t2.
- Continue to the timer function programming mode by grounding together two configuration wires.
- Configure timer function number and trigger mode.
- Continue to the timer output programming mode by grounding together two configuration wires.
- Configure timer output mode to either instant or gradual.
- Continue to the timer output type by grounding together two configuration wires.
- Configure timer output to either normal or reversed.
- Continue to the time programming mode by grounding together two configuration wires.
- Configure either normal or hours/minutes/seconds programming mode.

		CONFIGURATION WIRES	
STEPS		WHITE	GREEN
1	TIMING	t1	t2
2	FUNCTIONS	Timer Function	Trigger mode
3	OUTPUT MODE	Instant	Gradual Increase/Decrease
4	OUTPUT TYPE	Normal	Reversed
5	TIME PROGRAMMING MODE	Normal (Duration)	Hours/Minutes/Seconds

Here are sample configuration steps.

1. Connect timer as specified in the following diagram.

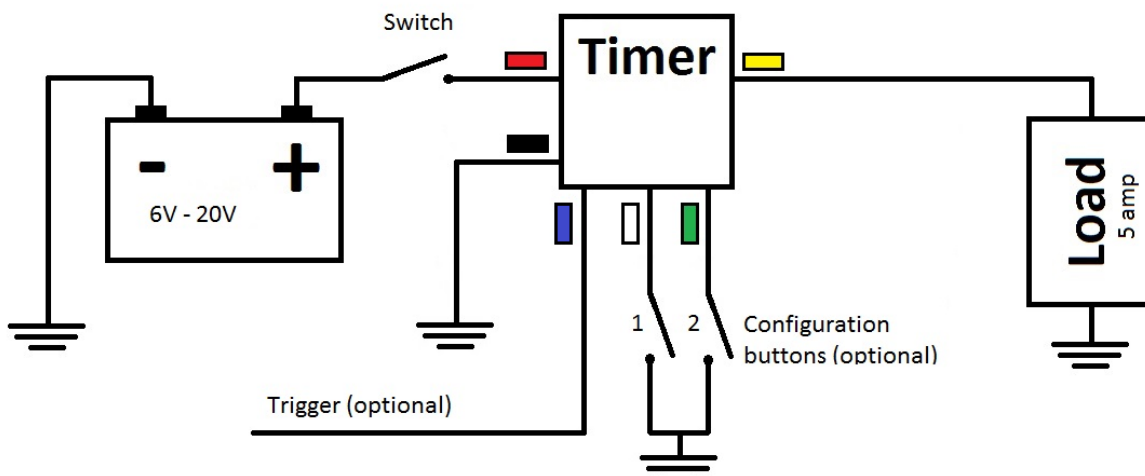

2. **Red** wire connects to power source, **Black** to ground and **Yellow** to output. **White** and **Green** are configuration wires and are used to configure the timer. Configuration wires can be connected to buttons

for ease of programming, but it is not necessary, especially if the timer is going to be configured only once. **Blue** wire is a trigger wire. Isolate trigger wire with electrical tape if trigger option is not used.

3. Select the appropriate timer function from **Figure 2** for your project and note the function number.
4. Skip this step if trigger is not used. Select the appropriate timer trigger configuration function from **Figure 5** and note the trigger number.
5. Go into the programming mode by connecting both configuration wires (**White** and **Green**) to the ground and then supply power to the timer. Disconnect configuration wires from the ground after 1 second. Power to the load will turn on for 3 seconds, indicating the timer entered programming mode. Timer is ready to be configured with time delay (t1) and (t2).
6. To program time delay (t1), short configuration wire (**White**) to the ground (or push button #1 if connected) and keep it connected to the ground for time required delay (t1), then release. Timer will supply power to the load when configuration wire is connected to the ground. To program time delay (t2) perform the same procedure with **Green** configuration wire.
7. Once time delay has been programmed move to the timer function and trigger configurations. Connect both configuration wires (**White** and **Green**) to the ground for 1 sec. Power to the load will turn on for 3 seconds.
8. To program timer function you need to know function number from **Figure2**. Use the configuration wire (**White**), short it to the ground and disconnect the number of times equal to the selected function number. If you connected button to configuration wires push button #1 the number of times equal to the selected function number. If you are unsure or need to repeat the steps, disconnect power from the timer and start with step 5.
9. If the trigger option is not used you can skip this step. To program timer trigger you need to know trigger configuration number **Figure5**. Use the configuration wire (**Green**), short it to the ground and disconnect the number of times equal to the selected trigger configuration number. If you connected button to configuration wires then push button #2 the number of times equal to the selected trigger number. If you are unsure or need to repeat the steps, disconnect power from the timer and start with step 5.
10. Once timer function and trigger has been programmed move to the timer output configuration. Connect both configuration wires (**White** and **Green**) to the ground for 1 sec. Power to the load will turn on for 3 seconds.
11. Connect and disconnect (**White**) configuration wire to the ground to configure instant output mode or use (**Green**) wire to select gradual increase/decrease pwm output. Instant output is programmed from the factory.
12. Once timer output mode has been programmed move to the time output type configuration. Connect both configuration wires (**White** and **Green**) to the ground for 1 sec. Power to the load will turn on for 3 seconds.
13. Connect and disconnect (**White**) configuration wire to the ground to configure normal output type or use (**Green**) wire to select reversed output. Normal output is programmed from the factory.
14. Once timer output mode has been programmed move to the time programming mode configuration. Connect both configuration wires (**White** and **Green**) to the ground for 1 sec. Power to the load will turn on for 3 seconds.
15. Connect and disconnect (**White**) configuration wire to the ground to configure normal programming mode or use (**Green**) wire to set hours/minutes/seconds programming mode.
16. Disconnect power from the timer. Isolate configuration wires with tape (if buttons are not used) .

****Tip: Once timer function, trigger and output are configured they do not have to be changed or reset. If only timer t1 and t2 needs to be changed then go into the programming mode, set t1 and/or t2 and disconnect power. Timer will retain prior configured timer function, trigger, output and programming mode settings.*

Below are sample timer configuration steps. (time function set to #2, trigger configuration set to #4, time delay (t) set to 5 seconds) with assumption configuration wires (**White** and **Green**) are connected to the buttons:

1. Push button #1 and #2.
2. Supply power to the timer, release button #1 and #2. (*Power to the load will turn on for 3 seconds.*)
3. Push button #1, hold for five seconds and release. (*Time delay 't1' is now set.*)
4. Push button #1 and #2 together for about 0.5seconds and release. (*Power to the load will turn on for 3 seconds.*)
5. Push button #1 and release two times. (*Time function is now set to# 2*)
6. Push button #2 and release four times. (*Trigger configuration is now set to #4*)
7. Disconnect power.

If buttons are not used then connect **White wire to the ground instead of button #1 and connect **Green** wire to the ground instead of button #2. Once configuration is done isolate configuration wires with electrical tape.*

Programming Tips (watch our YouTube *tips and tricks* video) :

- Timer programming YouTube Videos can be found [HERE](#).
- Program short (a couple seconds) time duration to test the timer functionality and configuration steps.
- Once functionality is verified update the time t1/t2 without changing timer function configuration.
- Timer duration t1/t2 can be updated independently from the function and trigger. Just perform steps 1 through 3 in above procedure skipping steps 4,5 and 6.
- Timer function also can be changed without resetting time delay. Perform above configuration steps 1 through 7 skipping step 3.

10. Reseting Timer to the factory settings.

To reset timer to the factory settings perform the following procedure:

- Connect WHITE/GREEN wires to the ground or push button #1 and #2.
- Supply power to the timer.
- When output comes on disconnect power while keeping WHITE/GREEN wires connected to the ground.
- Repeat supply and disconnect of power five times.
- On the fifth time the output will blink twice indicating full reset.

Timer is now reset to the factory settings and ready for new programming.

11.3 Use button to create self latching timer

With a push of the button circuit will supply power to the load until timer delay is expired. Timer should be set to function #2 and trigger disabled. It is great for battery powered applications as it consumes now power during off state.

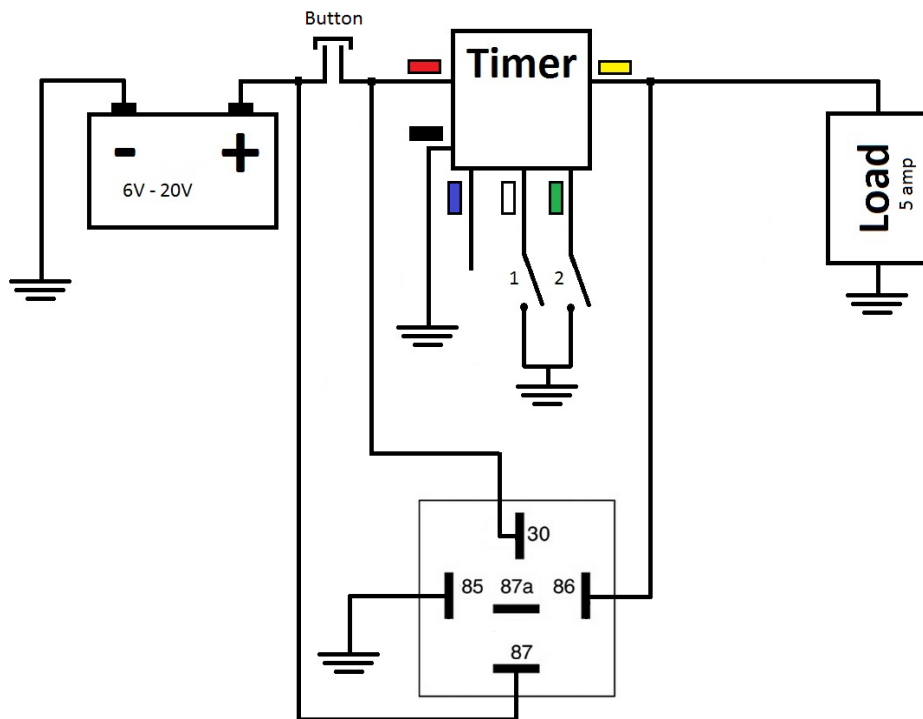

Alternatively timer can perform the same function without the relay. Timer should be set to function #2 and trigger to #4. Circuit consumes 4ma during power off state. If the circuit is not battery powered or there is no concern regarding 4ma current drain by the timer, then this circuit is preferred as it does not require a relay.

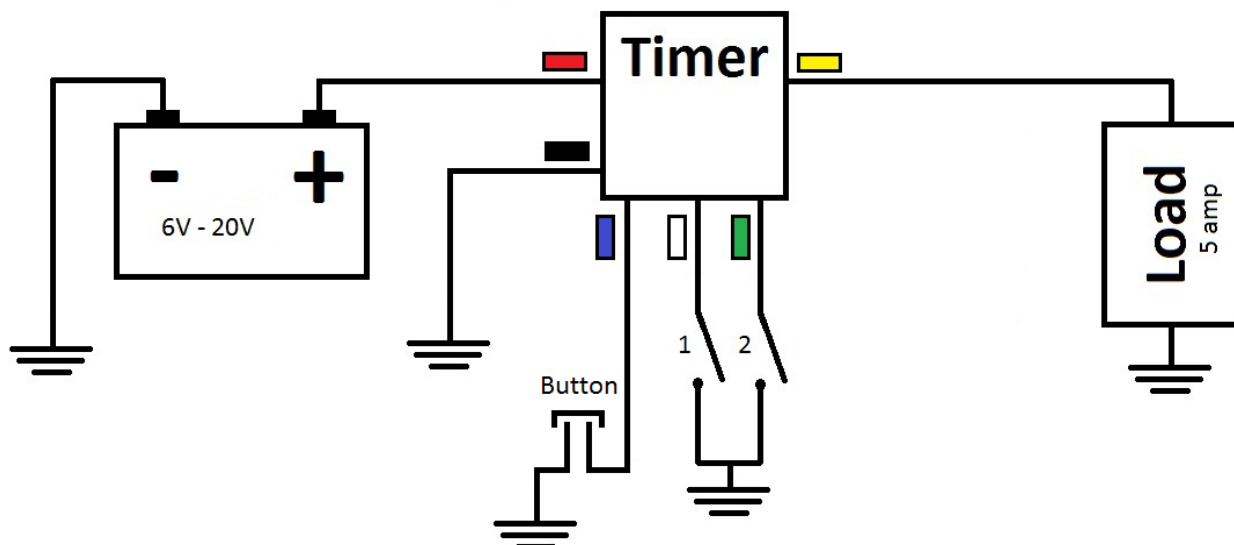

11.4 Use button to create self latching timer with ability to turn off

With a push of the button circuit will supply power to the load until timer delay is expired. Consecutive push of the button will turn off the timer. Timer should be set to function #16 and trigger to #2. It is great for battery powered applications as it consumes now power during off state.

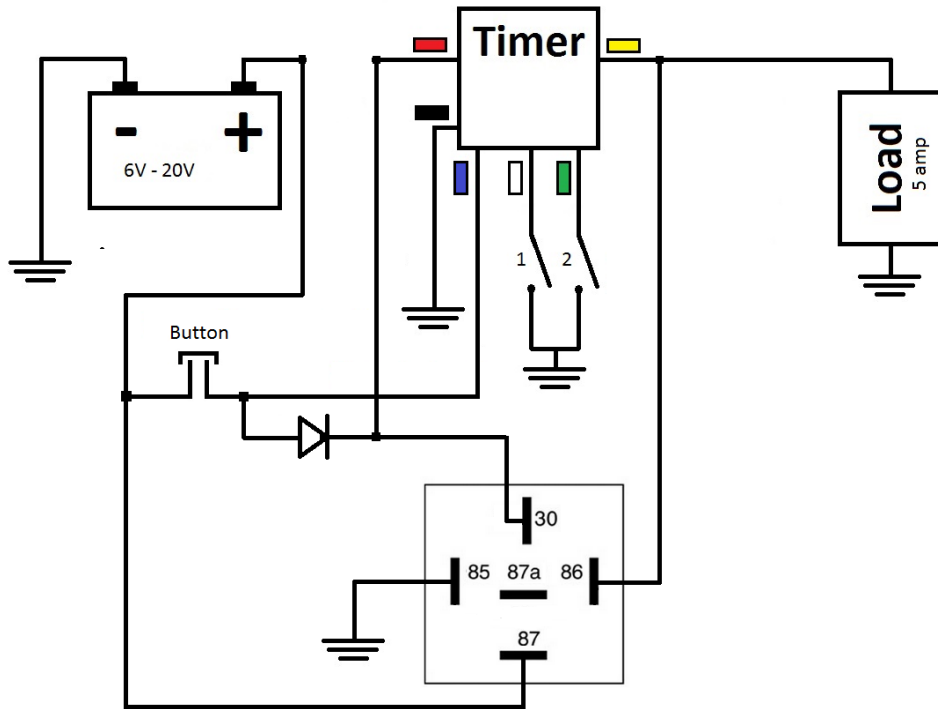

Alternatively timer can perform the same function without the relay. Timer should be set to function #16 and trigger to #4. Circuit consumes 4ma during power off state. If the circuit is not battery powered or there is no concern regarding 4ma current drain by the timer, then this circuit is preferred as it does not require a relay.

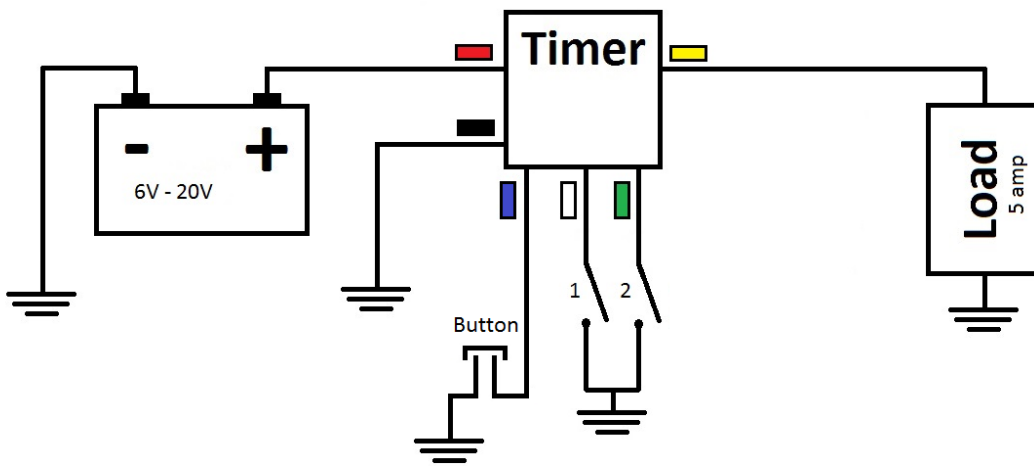

11.5 Delay Off timer with 0 power consumption in Off state

The following circuit accomplishes delay Off function with 0 power consumption during the Off phase. This circuit does not use a relay but only 10amp timer version can be used, as it has a separate wire to power internal circuitry. Example of application: you want for a car GPS unit to come On when ignition first is turned On, and continue to be On for 30min after the ignition is turned Off. Configure timer to Function #12 and set the Trigger to #2. The trigger is connected to the ignition wire. When the ignition receives power, timer's output turns On and supplies the power to itself through a diode. And when ignition voltage drops to 0v the timer starts the countdown and turns the output after a preset amount of time.

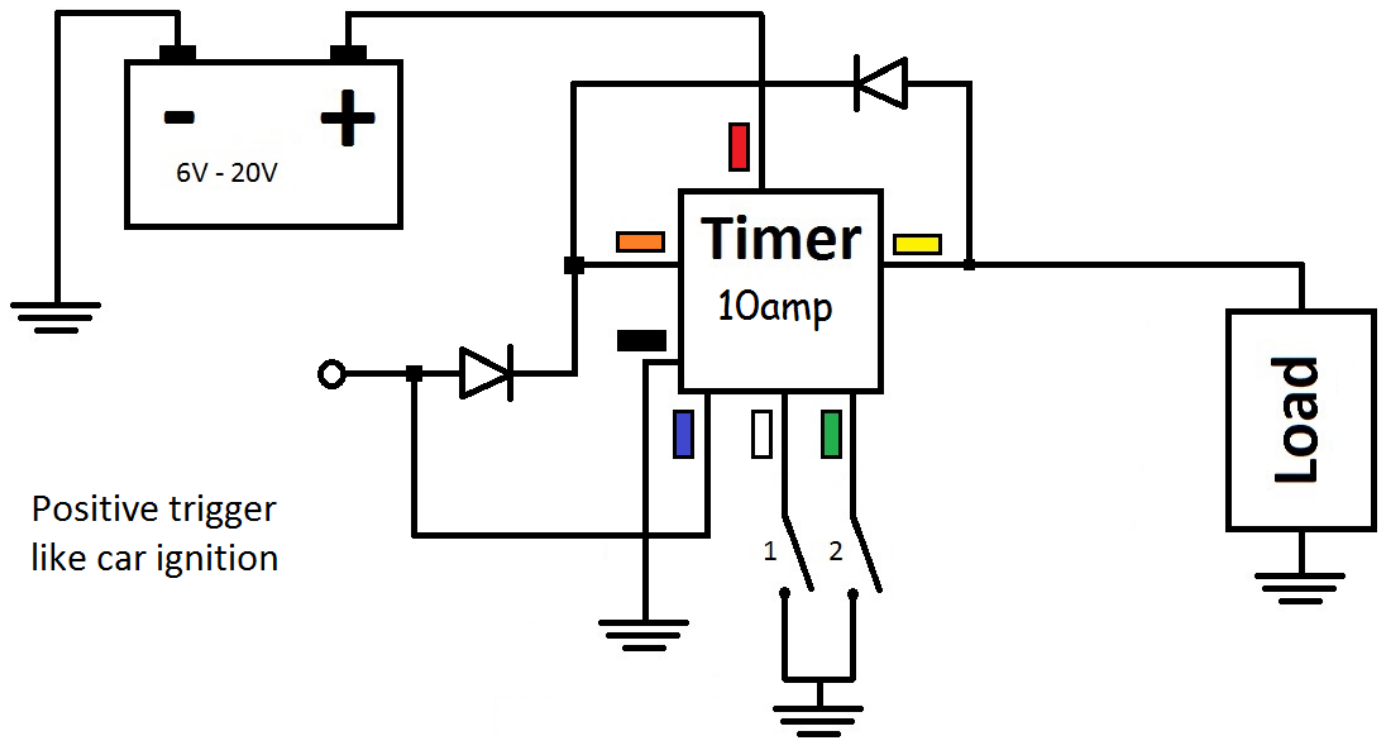

12. 10 amp Timer

10 amp timer version offers extended power handling and also features separated power for timer control (**Orange**) and output circuits (**Red**). The following diagram shows how the 10 amp timer can be used instead of 5 amp timer. The power should be supplied to both **Red** and **Orange** wires.

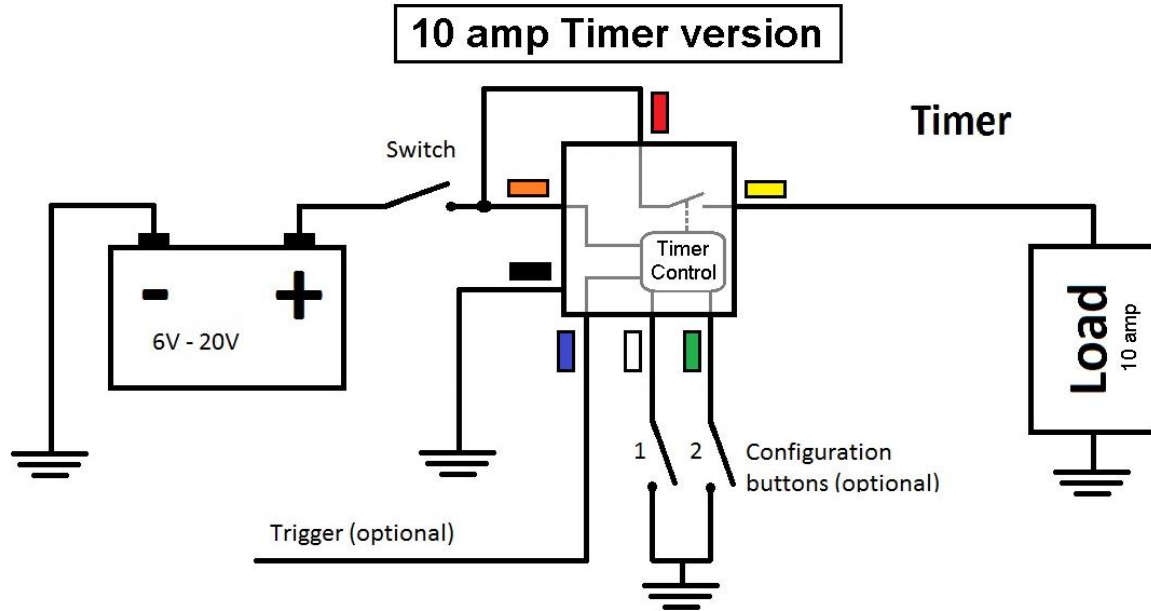

Separating power for timer circuit and timer output provides greater application flexibility. It allows for timer to be connected directly to power supply battery but control the timer function with lower power signal like car or motorcycle ignition wire. With ignition OFF the timer has zero stand-by current consumption which is great for battery powered applications. With ignition ON timer performs required timer function.

The following configuration can be used to delay the power to motorcycle accessories after ignition is switched ON.

13. 10 amp Timer with LCD

10 amp timer with LCD option offers the same functionality as 10 amp version, but with ability to configure all the parameters via LCD screen. This functionality is great for prototyping where the time, function and trigger configurations can be viewed and quickly updated. LCD is only need to be connected during the timer configuration.

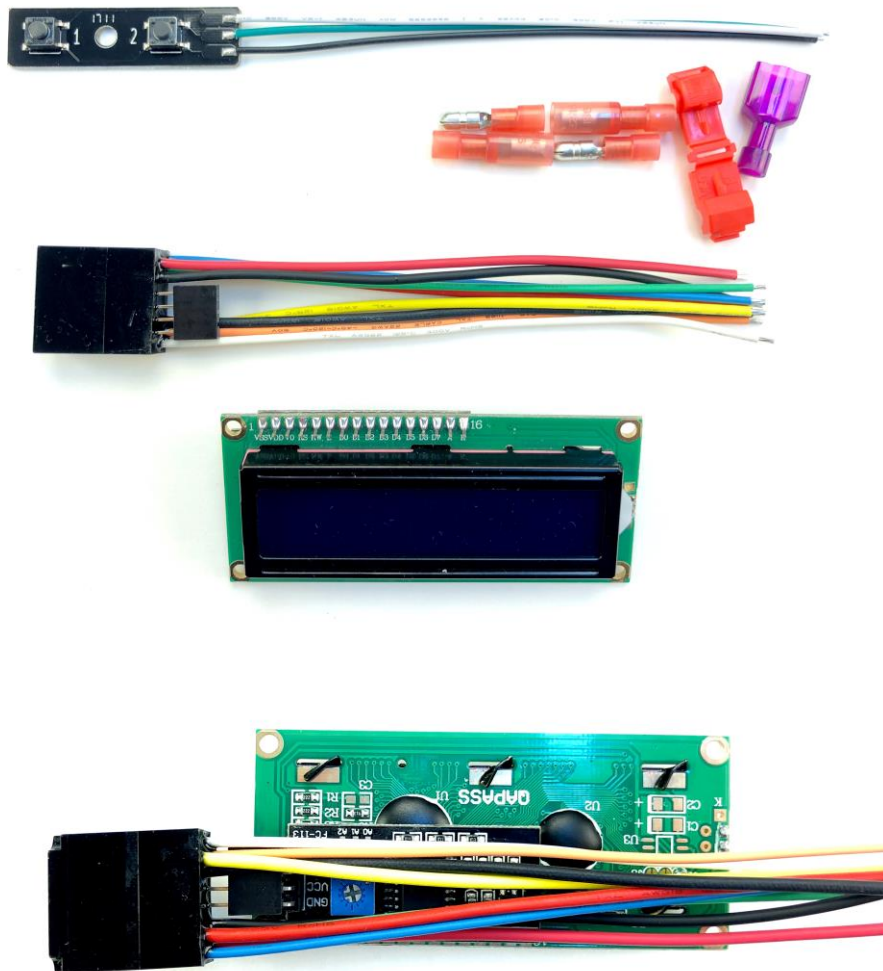

14. Accessories

14.1 Timer configuration button board

Timer configuration button board is an option accessory. It connects to the timer's configuration wires and simplifies timer programming. Two buttons are used to put timer into the programming mode and set timing, function, trigger, output and related parameters.



15. YouTube Videos

[Multi-functional timer introduction](#)

[Multi-functional timer connection and configuration](#)

[Multi-functional timer programming](#)

[10 amp timer with LCD](#)

[10 amp timer with Real Time Clock \(RTC\)](#)