



SOUNDBAR | 120W

support@vmaiTech.com

Instruction Manual

Important Safety Instruction

Thank you for purchasing the VMAI Soundbar. Please read this user manual carefully and keep it for future reference. If you need any assistance, please contact our support team: support@vmaiTech.com with your product model number and Amazon order number.

Warning

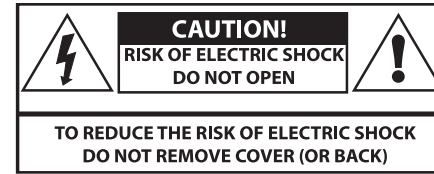

Caution:

To reduce the risk of electric shock, do not dismantle the product and do not expose the apparatus to rain or moisture. No user-serviceable parts inside. Refer servicing to qualified personnel only



The lightning flash within an equilateral triangle is intended to alert you to the presence of uninsulated dangerous voltage within the product's enclosure that may be of sufficient magnitude to constitute an electric shock to a person or persons.



Important! This symbol alerts you to read and observe important warnings and instructions on the unit or in this manual.

Notice:

This appliance is not intended for use by person (including children) with reduced physical sensory or mental capabilities, or lack of experience and knowledge, unless they have been given supervision or instruction concerning use of the appliance by a person responsible for their safety. Children should be supervised to ensure that they do not play with the appliance.

1. To prevent possible hearing damage, do not listen at high volume levels for long time periods or a sudden high volume level. 
2. Never use the device unsupervised! Switch off the device whenever you are not using it, even if this only for a short while.
3. The appliance is not intended to be operated by means of an external timer or separate remote control system.
4. If the supply cord is damaged, it must be replaced by the manufacturer, its service agent or similarly qualified person in order to avoid a hazard.
5. Before operating this system, check the voltage of this system to see if it is identical to the voltage of your local power supply.

6. The unit should not be impeded by covering the ventilation opening with items such as newspaper, table-cloths, curtains etc. Make sure that there are at least 20 cm of space above and at least 5 cm of space on each side of the unit.
7. The apparatus must not be exposed to dripping or splashing and that objects filled with liquids, such as vases, must not be placed on the apparatus.
8. To prevent fire or shock hazard, do not expose this equipment to direct heat, rain, moisture or dust.
9. Do not locate this unit near any water sources e.g. taps, bathtubs, washing machines or swimming pools. Ensure that you place the unit on a dry, stable surface.
10. Do not place this unit close to a strong magnetic field.
11. Do not place the unit on a amplifier or receiver.
12. Do not place this unit in a damp area as the moisture will affect the life of electric components.
13. Do not attempt to clean the unit with chemical solvents as this might damage the finish. Wipe with a clean, dry or slightly damp cloth.
14. When removing the power plug from the wall outlet, always pull directly on the plug, never pull on the cord.
15. Depending on the electromagnetic waves used by a television broadcast, if a TV is turned on near this unit while it is also on, lines might appear on the TV screen. Neither this unit nor the TV is malfunctioning. If you see such lines, keep this unit well away from the TV set.
16. The mains plug is used to disconnect the device, the disconnected device should remain readily operable.

Important Safety Instructions

1. Read these instructions. Keep these instructions. Follow all instructions. Heed all warnings.
2. Do not use this apparatus near water.
3. Clean only with dry cloth.
4. Do not block any ventilation openings. Install in accordance with the manufacturer's instructions.
5. Do not install near any heat sources such as radiators, heaters, stoves, or other apparatus (including amplifiers) that produce heat.
6. Do not defeat the safety purpose of the polarized or grounding-type plug. A polarized plug has two blades with one wider than the other.
7. Protect the power cord from being walked on or pinched particularly at plugs, convenience receptacles or at the point where they exit from the apparatus.
8. Only use attachments/accessories specified by the manufacturer.
9. Unplug this apparatus during lightning storms or when unused for long periods of time.

10. Refer all servicing to qualified service personal. Servicing is required when the apparatus has been damage in any way, for example, when the power-supply cord or plug is damaged, liquid has been spilled or objects have fallen into the apparatus, the apparatus has been exposed to rain or moisture, does not operate normally, or has been dropped.
11. The AC plug is used to disconnect the device, the disconnected device should remain readily operable. In order to disconnect the apparatus from the AC power completely, the AC plug must be removed from the AC outlet completely.

Preparation for Use

Unpacking and Set Up

- Remove the Sound bar from the carton and remove all packing material from the Sound bar. Save the packing material, if possible, in case the Sound bar ever needs to be serviced or transported. The original carton and packing material is the only safe way to pack your Sound bar to protect it from damage in transit.
- Remove any descriptive labels or stickers on the front or top of the cabinet. Do not remove any labels or stickers from the back or bottom of the cabinet.
- Place your Sound bar on a level surface such as a table, desk or shelf, convenient to an AC outlet, out of direct sunlight, and away from sources of excess heat, dirt, dust, moisture, humidity, or vibration.
- Unwind the Line cord connecting the AC adapter and extend it to its full length.

Protect Your Furniture

This model is equipped with non-skid rubber 'feet' to prevent the product from moving when you operate the controls. These 'feet' are made from non-migrating rubber material specially formulated to avoid leaving any marks or stains on your furniture. However certain types of oil based furniture polishes, wood preservatives, or cleaning sprays may cause the rubber 'feet' to soften, and leave marks or a rubber residue on the furniture. To prevent any damage to your furniture we strongly recommend that you purchase small self-adhesive felt pads, available at hardware stores and home improvement center everywhere, and apply these pads to the bottom of the rubber 'feet' before you place the unit.

Power Source

This sound bar is designed to operate on normal AC power source. For North America, it works only under SMPS 110V-240V~50hz/60Hz. Do not attempt to operate the Sound bar on any other power source. You could cause damage to the Sound bar that is not covered by your warranty.

Important Notes

- This sound bar was especially developed for LED/LCD/Plasma TV's: It should not be used in combination with CRTTV's (Cathode Ray Tube TV's) in order to avoid image interference.
- Safety and operating instruction manual should be retained for future reference.
- The apparatus should not be exposed to dripping, splashing or placed in a humid atmosphere such as a bathroom.
- Do not install the product in the following areas:
 - Places exposed to direct sunlight or close to radiators.
 - On top of other stereo equipment that radiate too much heat -Blocking ventilation or in a dusty area.
 - Areas where there is constant vibration.
 - Humid or moist places.
 - Near candles or other flames.
- Operate the product only as instructed in this manual.
- Before turning on the power for the first time, make sure the sound bar is plugged to power outlet.
- For safety reasons, do not remove any covers or attempt to gain access to the inside of the product. Refer any servicing to qualified personnel.
- Do not attempt to remove any screws, or open the casing of the unit; there are no user serviceable parts inside. Refer all servicing to qualified service personnel.

Soundbar Controls and Connections

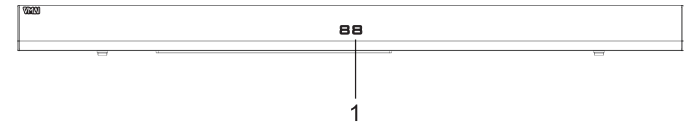

BACK VIEW

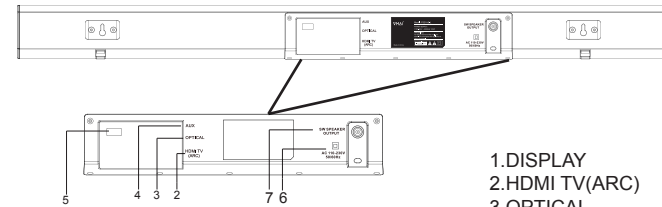

- 1.DISPLAY
- 2.HDMI TV(ARC)
- 3.OPTICAL
- 4.AUX
5. USB
- 6.AC IN
- 7:SW SPEAKER OUTPUT

SIDE VIEW

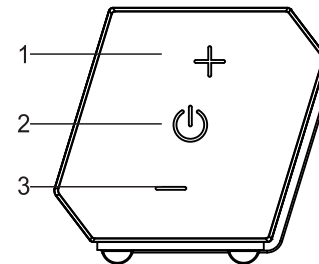

- 1.Vol+
- 2.Standby
3. Vol-

SUBWOOFER VIEW

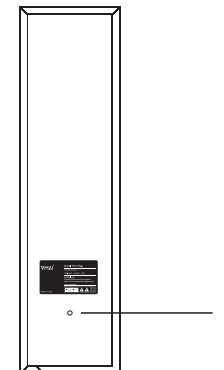

1. SW SPEAKER OUTPUT

Remote Control

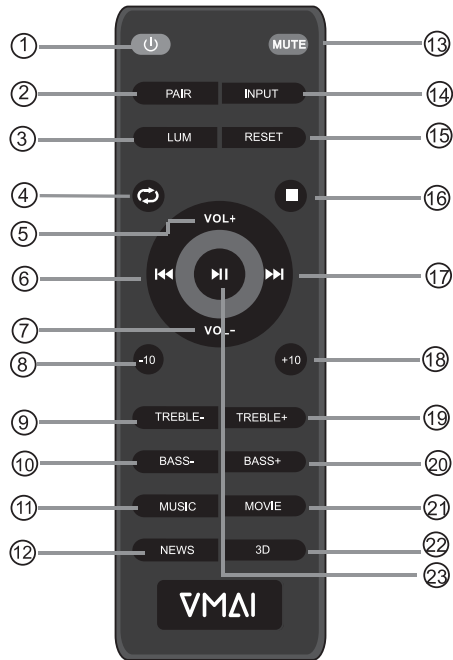

- | | |
|---|--|
| 1. Standby mode for power on/off. | 13. MUTE mode. |
| 2. PAIR: Connect or disconnect to the pairing device. (Press the button more than 2 seconds). | 14. INPUT: AUX/OPT/USB/BT/HDMI selection |
| 3. LUM: Brightness control. This button can't work under standby status. | 15. RESET: Reset all sound bar volume levels and switch EQ back to music setting. Press and hold button for 2 seconds. |
| 4. Loop playback (Only work under USB mode). | 16. Stop button: Press to stop. (Only work under USB mode). |
| 5. Volume + | 17. Next button: Next song. (Only work under USB & BT mode). |
| 6. Pre button: Previous song (Only work under USB & BT mode) | 18. +10: Forwards ten songs. (Only work under USB mode). |
| 7. Volume - | 19. Treble + |
| 8. -10: Backwards ten songs (Only work under USB mode). | 20. Bass + |
| 9. Treble - | 21. MOVIE: Select the MOVIE EQ effect. |
| 10. Bass - | 22. 3D: Select the 3D EQ effect. |
| 11. MUSIC: Select the MUSIC EQ effect. | 23. Play/Pause (Only work under USB and BT mode). |
| 12. NEWS: Select the NEWS EQ effect. | |

Remote Control Battery Replacement

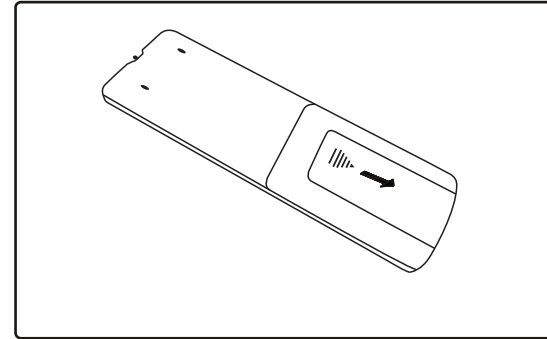

A. Remove the battery compartment cover.

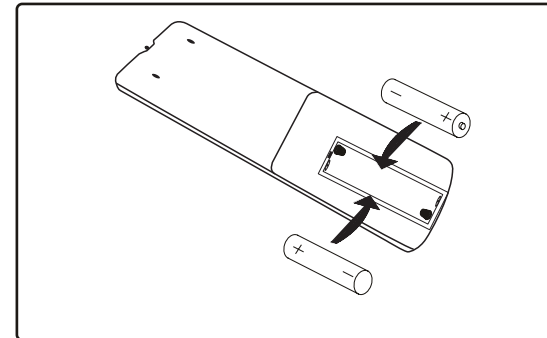

B. Insert 2 AAA batteries according to the marking inside compartment.

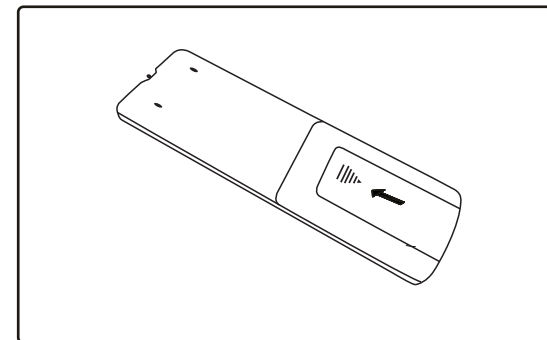

C. Close the compartment.

OPERATE INSTRUCTIONS

Setting the Soundbar

1: Switch on the soundbar by using power button on soundbar, or by using STANDBY button on remote. After switching on, the default input mode will appear on display.

2: Input modes can be changed by pressing the power button on soundbar again, or by using the INPUT button on the remote.

Below are input mode names appearing in the soundbar display:



Note: USB input mode is not available in the source selection. It will get enabled only after inserting a compatible USB Drive (appears as US in the display)

Pairing Mode

Connect:

1. Plug in the power cord and the display will light up (stand by mode).
2. Switch on the soundbar using power button and change the input mode to BT.
3. Search for new device on your Bluetooth player. (smartphone, tablet, computer). Choose the device named **Vmai S4** in the list of new devices detected and select it. If a password is asked, just type 0000. The "BT" display will stop flashing when the sound bar is paired successfully. You don't need to make this pairing procedure again the next time you connect the same device to the sound bar, it will be re-connected automatically when it is close to the sound bar with BT input mode activated.

Note: When unable to detect the soundbar while pairing, please restart both device and try pairing again.

Disconnect:

Go to the Bluetooth setting of your smart device, select **Vmai S4** in the list of devices and choose the option (disconnect). Note that if the sound bar is connected with a Bluetooth device, you need to disconnect from the first device in order to connect to second device.

AUX Mode

1. After Turn on the soundbar, change to AUX input mode.
2. plug in the 3.5mm AUX cable to the AUX IN connector on the soundbar and start playing from the music device.

USB Mode

1. Plug in the USB drive. (Flash Drive ONLY! Does NOT support other device connect via USB!)
2. The music from the USB drive will play automatically, and you can use the remote controller to control.

HDMI(ARC) Mode

1. Using the HDMI cable connect to the tv. (not included)
2. Using a High-Speed HDMI (1.4 or 2.0) cable, connect the HDMI TV(ARC) connector on the sound bar to the HDMI ARC connector on the TV. (HDMI ARC port on TV may be labelled differently. For details, see the TV user manual.)
3. On your TV, select source as HDMI(ARC) mode. For details, see the TV user manual.
4. Go to Setting in your TV menu (may vary due to different brand):
 1) Setting > Sound > Select Speaker to: external speaker (ARC Mode)/ turn off TV Speaker
 2) Setting > Sound(audio) > advanced Audio > digital audio output > PCM Setting > Sound(audio) > audio output format > PCM/ Dolby off

Optical Mode

1. Using the provided optical cable connect to the tv.
2. Select optical mode using the remote by pressing the INPUT button, and the sound bar indicator will show OP.
3. Go to Setting in your TV menu (may vary due to different brand):
 1) Setting > Sound > Select Speaker to: external speaker (optical mode)/ turn off TV Speaker
 2) Setting > Sound(audio) > advanced Audio > digital audio output > PCM Setting > Sound(audio) > audio output format > PCM/ Dolby off

TROUBLESHOOTING

ISSUES	PROBLEMS	SOLUTIONS
Sound	No sound from SoundBar speakers (Common issue)	If you are experiencing no sound using ARC/ Optical Mode, please check your TV setting, and follow the instruction on top of this page to set your TV in the correct setting. On the remote control, select the correct audio input.
	Distorted sound or echo	If you play audio from the TV through the SoundBar, make sure that the TV is muted.
Connection	A device cannot connect with the SoundBar	Restart the soundbar and try pairing again
		You have not enabled the "BT" function of the device. See the user manual of the device on how to enable the function.
		The device is not correctly connected. The SoundBar is already connected with another Bluetooth device. Disconnect the connected device, then try again.
Quality of audio play from a connected Bluetooth device is poor.	The Bluetooth reception is poor. Move the device closer to the SoundBar, or remove any obstacle between the device and the SoundBar.	
The connected Bluetooth device connects and disconnects constantly	The Bluetooth reception is poor. Move the device closer to the SoundBar, or remove any obstacle between the device and the SoundBar.	

IMPORTANT: If you need any assistance, don't hesitate to Contact us: support@vmaiTech.com Here at Vmai, we truly value customer satisfaction!