

尺寸:160*160mm

装订成册

材质:封面128克铜版纸 内页80克书纸

Model:
TT-AH025



www.taotronics.com

ASIA PACIFIC

E-mail: support.jp@taotronics.com(JP)

Tel: 03-5542-0238 (10~18時/土日祝除く)

JP Importer: 株式会社SUNVALLEY JAPAN

Address: 〒104-0032東京都中央区八丁堀 3丁目18-6 PMO京橋東9F

EUROPE

E-mail:

support.uk@taotronics.com(UK)

support.de@taotronics.com(DE)

support.fr@taotronics.com(FR)

support.es@taotronics.com(ES)

support.it@taotronics.com(IT)

EU Importer: ZBT International Trading GmbH

Address: Halstenbeker Weg 98C, 25462 Rellingen, Deutschland

NORTH AMERICA

E-mail : support@taotronics.com(US)

support.ca@taotronics.com(CA)

Tel : 1-888-456-8468 (Monday-Friday: 9:00 - 17:00 PST)

US Distributor: SUNVALLEYTEK INTERNATIONAL INC.

Address: 46724 Lakeview Blvd, Fremont, CA 94538

MANUFACTURER

Manufacturer: Shenzhen NearbyExpress Technology Development Co.,Ltd.

Address: 333 Bulong Road, Shenzhen, China, 518129

Learn more about the EU Declaration of Conformity:

<https://www.taotronics.com/downloads-TT-AH025-CE-Cert.html>

Made in China



CAN ICES-3 (B)
/NMB-3 (B)

TT-AH025_V1.0 EN



Extend your warranty to 18 months by
registering your product on our website
taotronics.com/warranty:

support@taotronics.com(US)
support.ca@taotronics.com(CA)
support.uk@taotronics.com(UK)

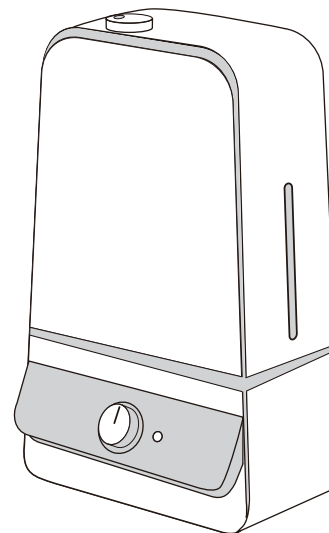

MODEL: TT-AH025
ULTRASONIC COOL MIST HUMIDIFIER
User Manual

CONTENTS

STATEMENT	01
SAFETY INSTRUCTIONS	01
BEFORE USING THE HUMIDIFIER	02
WHEN USING THE HUMIDIFIER	03
AFTER USING THE HUMIDIFIER	04
PACKAGE CONTENTS	05
SPECIFICATIONS	05
PRODUCT DIAGRAM	06
OPERATIONS AND FUNCTIONS	07
Add Water	07
Power On / Off	08
Light Control	08
Low Water Protection: Auto Shut-off the Humidifier	08
CLEANING AND MAINTENANCE	09
Caution	09
Daily Maintenance	09
Weekly Maintenance	09
Scale Removal Instructions	10
Disinfecting Instructions	11
Clean the Dustproof Sponge	12
End-Of-Season Care and Storage	12
TROUBLESHOOTING GUIDE	13/15
WARRANTY	16
TAOTRONICS CUSTOMER CARE	16

STATEMENT

Thank you for purchasing a TaoTronics product that has been tested to meet our stringent quality standards. This product is covered with TaoTronics product and labor warranty for **12** months from the date of its original purchase.

Please email us with your order ID and problem or issue via support@taotronics.com, we will respond within 24 hours.

Please read the User Manual thoroughly. Clean and maintain the product as instructed. If any abnormalities occur, please refer to the Troubleshooting Guide first.

This warranty is void if the defect is caused by accidental damage, misuse, abuse, neglect, improper repair or alteration by unauthorized persons, or a failure to follow operating instructions provided with the product including adding essential oils directly into the tank and base. This warranty does not apply to normal wear and tear or commercial use.

In no event shall liability exceed the purchase price paid by the purchaser of the product. Under no circumstances shall there be liability for any loss – direct, indirect or incidental – or consequential damage arising out of, or in connection with the use of the product.

SAFETY INSTRUCTIONS

The humidifier was made with safe and environmental protection materials, it has been certified and complied with the requirement of sale regions' related regulations or laws.

IMPORTANT: Please read and save this SAFETY INSTRUCTIONS before using the device. Basic precautions should always be followed to reduce the risk of fire, electrical shock, and injury to persons or damage to the product.

BEFORE USING THE HUMIDIFIER

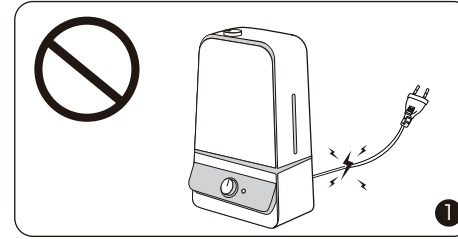

1. Please check the cord for any signs of damage. Do not use the humidifier if the cord has been damaged.

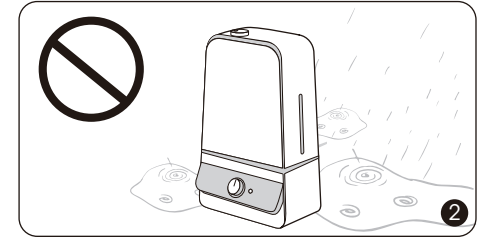

2. DO NOT place this humidifier in wet environments.

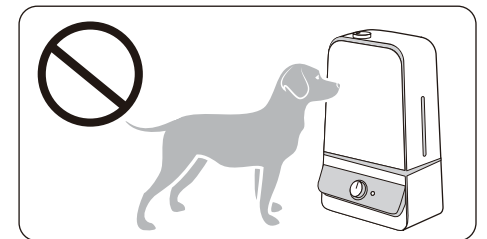

Please always keep the humidifier out of reach of patients & children & pet.

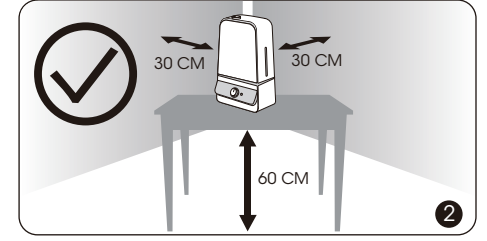
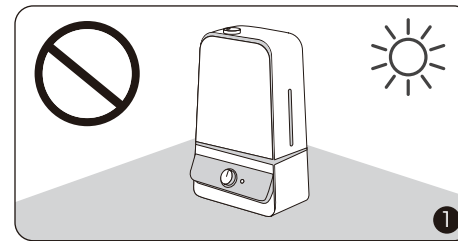

1. Please always place the unit on a smooth, flat, lint-free, non-metallic, waterproof and level surface and keep it away from direct sunlight.

2. Always place the unit 2 feet (60 cm) above the floor, 12 inches (30 cm) away from the wall, other appliances or wooden furniture.

WHEN USING THE HUMIDIFIER

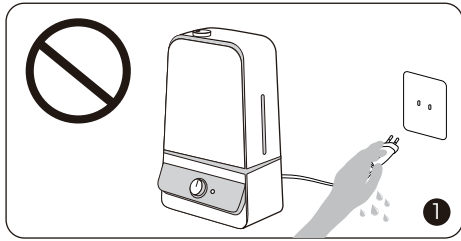

1. DO NOT plug the unit with wet hands.
2. DO NOT direct the mist nozzle against the wall.

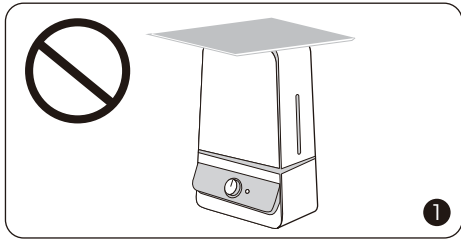
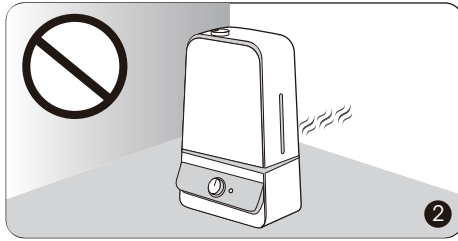

1. DO NOT use your hand or any other object to cover the nozzle while the unit is on to avoid damaging the product or causing injury.
2. DO NOT clean the unit while it is connected to a power source or while it is on.

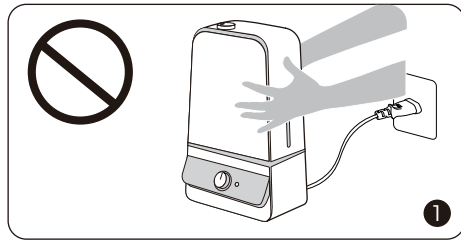

1. DO NOT move or tilt the humidifier while it is in operation.
2. The most comfortable environmental humidity is between 40%-60%. Please adjust the mist as needed.

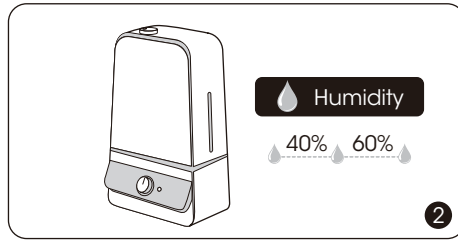

AFTER USING THE HUMIDIFIER

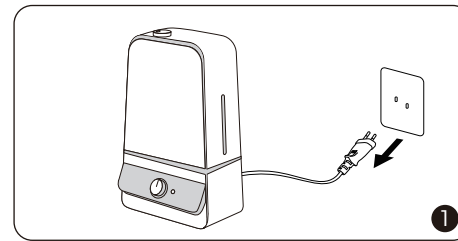

1. Always disconnect from a power source by pulling out the plug when not in use.
2. Humidifier requires regular cleaning. Please refer to, and follow the Cleaning and Maintenance instructions.

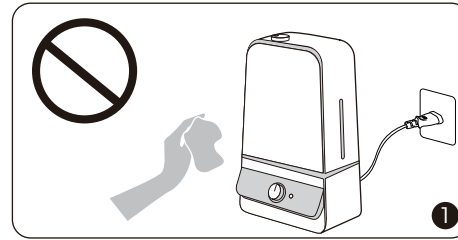
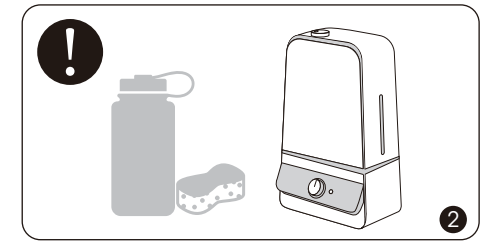

1. DO NOT clean the humidifier right after turning it off if the humidifier is warm to touch. Allow the humidifier to completely cool down before cleaning.
2. DO NOT attempt to repair or adjust any electrical or mechanical functions on this humidifier. Doing so will void your warranty.

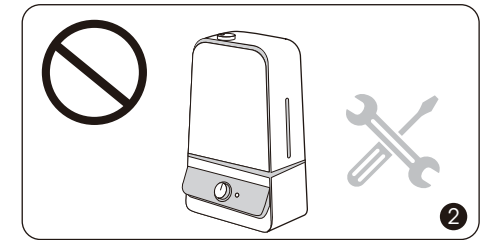

PACKAGE CONTENTS

- 1 x TaoTronics Humidifier (Model: TT-AH025)
- 1 x Cleaning Brush
- 1 x Dustproof Sponge
- 1 x Thank You Card
- 1 x User Manual

SPECIFICATIONS

Model	TT-AH025
Operating Voltage	AC 100-120V 50 / 60Hz
Rated Power	Min: 15W Max: 25W
Water Tank Capacity	6.0L / 1.59Gal
Mist Output	Min: 60ml/h Max: 300ml/h
Working Time on a Full Tank	20-60h
Recommended Room Size	20-40m ² / 215-430ft ²
Noise	≤35dB
Dimensions	251 x 167 x 412mm / 9.9 x 6.6 x 16.2in
Net Weight	1775g/62.6oz

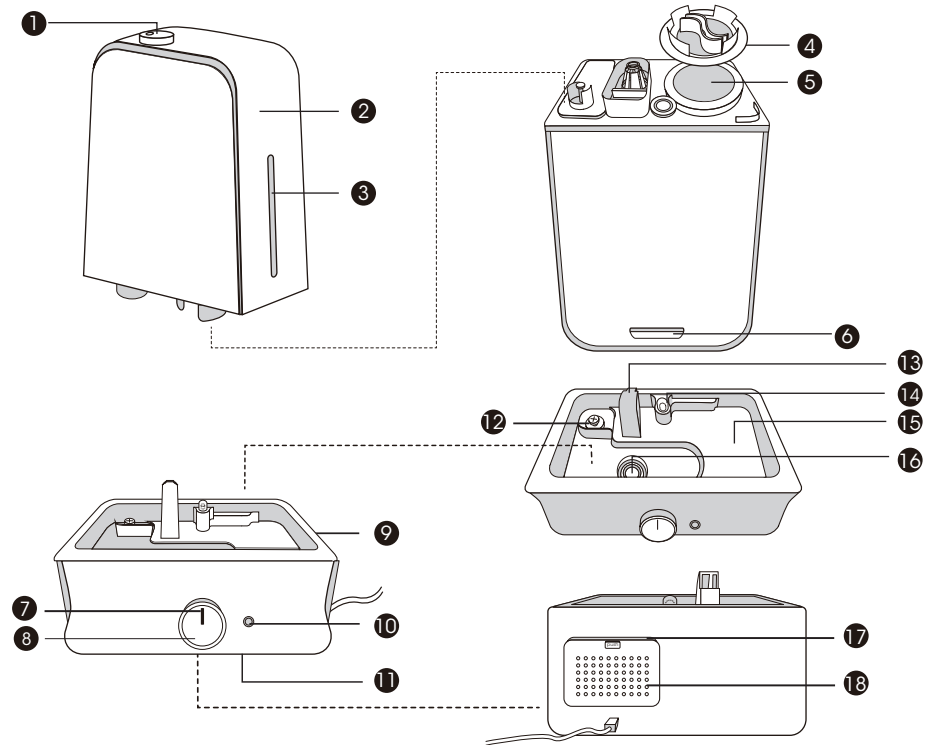

PRODUCT DIAGRAM

- | | |
|-----------------------|----------------------|
| 1. Nozzle | 10. Light Button |
| 2. Water Tank | 11. Night Light |
| 3. Water Level Window | 12. Floater |
| 4. Tank Cap | 13. Air Outlet |
| 5. Water Inlet | 14. Tank Light |
| 6. Handle | 15. Water Reservoir |
| 7. LED Indicator | 16. Atomizer |
| 8. Control Knob | 17. Dustproof Sponge |
| 9. Base | 18. Air Inlet |

OPERATIONS AND FUNCTIONS

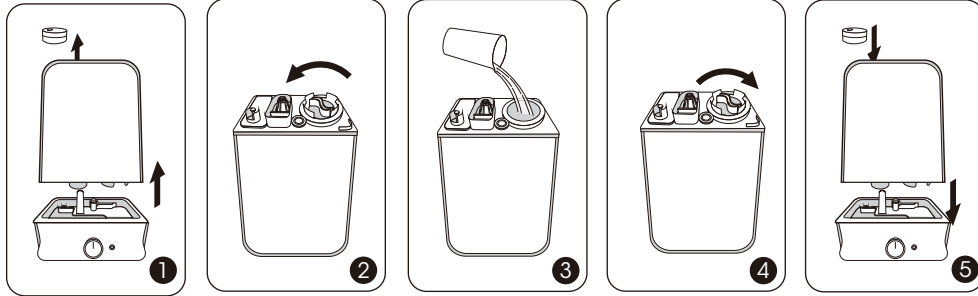

Add Water

1. Remove the nozzle and turn the water tank upside down.
2. Remove the tank cap and fill the tank with clean and cool water only.
3. Attach the tank cap and place the tank back onto the base. Make sure it fits together securely so that water can go from the tank to the reservoir. Put the nozzle back on.

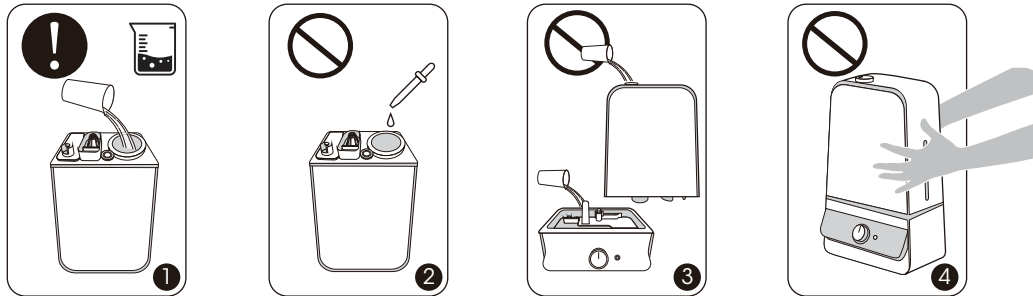

1. If tap water is too hard, it is recommended to use filtered or distilled water to avoid white dust. DO NOT use hot water.
2. DO NOT add any essential oils or medicinal tablets into the water tank.
3. DO NOT add water into the base or through nozzle.
4. DO NOT move the humidifier while the water tank is full of water to avoid leakage or base overflowing.

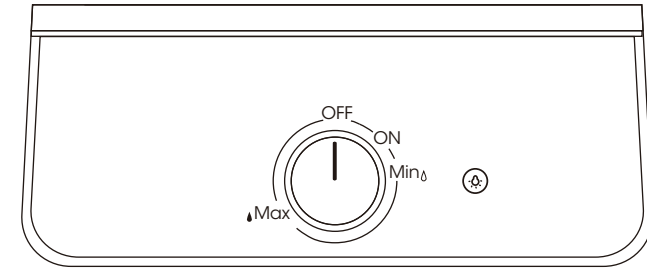

Power On / Off and Mist Adjustment

Plug the power cord into a wall socket. Now the humidifier is ready for use.

1. Rotate the control knob clockwise to the ON position. The blue LED indicator will light up indicating that the humidifier has been turned on.
2. Keep rotating the control knob clockwise to increase the mist level.
3. Rotate the control knob counterclockwise to decrease the mist level.
4. Rotate the control knob counterclockwise to the OFF position to turn off the humidifier. The LED indicator will turn off. The fan will work for another 3 minutes to dry the mist tube.

Note:

The most comfortable environmental humidity is between 40%-60%. Please adjust the mist output as needed.



Light Control

1. Press the Light Button to turn on / off the night light.
2. Press and hold the Light Button for 1.5 seconds to turn on / off the tank light.

Low Water Protection: Auto Shut-off the Humidifier

When there is not enough water inside the water reservoir, the humidifier will stop misting and the LED indicator will become red. It is designed for safety concern to prevent the humidifier from possibly overheating and damaging the atomizer.

CLEANING AND MAINTENANCE

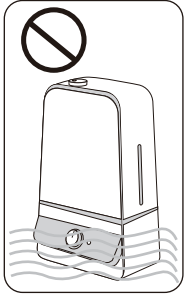

Caution

1. DO NOT submerge the base in water.
2. Make sure water does not enter the base through the air outlet, air inlet, or the control knob and light button.
3. DO NOT wash any part of this humidifier in dish washer which will damage the humidifier and void the warranty.

Daily Maintenance

Turn off the humidifier, unplug it from the power source. Drain water from the tank, reservoir and base.

Weekly Maintenance

1. To properly clean your humidifier, we recommend you to remove scale and disinfect the humidifier separately.
2. DO NOT mix vinegar and bleach solutions together. Do not use more than 1 tsp. of bleach per gallon of water to avoid damaging your humidifier.
3. Please make sure the rubber ring & rubber cap & spring on the tank cap is installed properly after cleaning to avoid water leakage. Please refer to the diagram on page 13.

Scale Removal Instructions

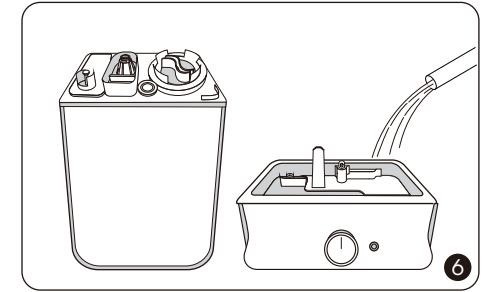
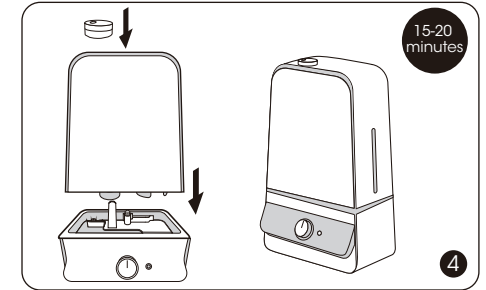
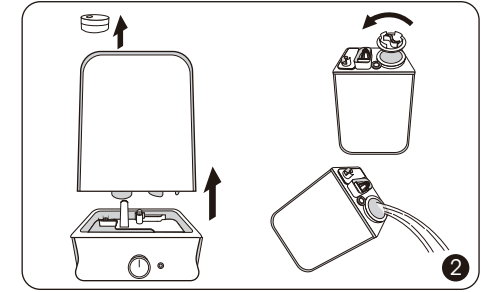
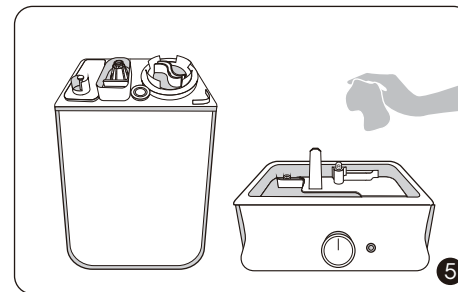
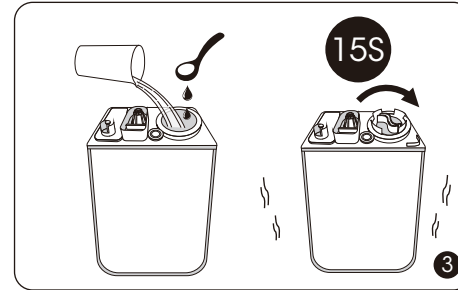
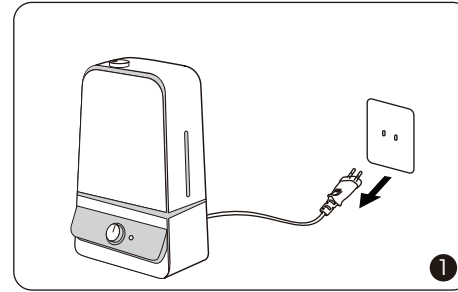

1. Turn off and unplug the humidifier. Remove the nozzle.
2. Remove the water tank from the base. Remove the tank cap. Make sure that the white sealing ring does not come off. Drain water from the water tank and base. Remove any accessories and set them aside.
3. Fill the water tank half full. Add 1 teaspoon of undiluted distilled white vinegar. Attach the tank cap and shake the tank for 15 seconds.
4. Place the tank onto the base. The vinegar solution will enter the water reservoir to loosen mineral buildup (scale) on the atomizer, water floater and the bottom of the water tank. Set it still for 15-20 minutes.
5. Uncap the tank cap and drain the solution. Wipe the atomizer and floater with a soft cloth to remove loosened mineral deposits.
6. Rinse both the water reservoir and water tank until the smell of vinegar (for scale removal) or bleach solution (for disinfecting, see below) is gone.

Disinfecting Instructions

1. Follow steps 1-2 of the previous section on scale removal.
2. Fill the water tank half full. Add ½ tsp of bleach. Place the tank cap back on. Swish the solution around in tank. Place the tank on the base. The bleach solution will enter and disinfect the water reservoir as well as the other components. Set it still for 15-20 minutes.
3. Follow steps 4-6 of the previous section on scale removal to complete disinfecting the humidifier.

Clean the Dustproof Sponge

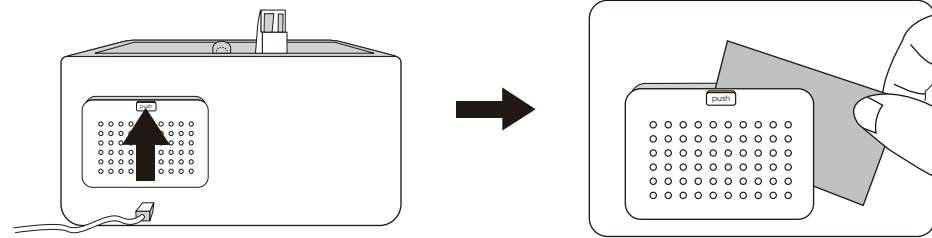

Clean the dustproof sponge (at the back of base) with water or detergent once a month. Put it back in place after cleaning.

End-Of-Season Care and Storage

1. Follow the cleaning instructions when the humidifier will not be used for at least one week, or at the end of the season. Remove any accessories used with the humidifier and allow the humidifier and accessories to dry completely before storing.
2. DO NOT store with water inside the base, water reservoir, or tank.
3. Pack the unit safely and store in a cool, dry location.

TROUBLESHOOTING GUIDE

1. If the information listed in the troubleshooting guide can't solve your problem, please email us for help.
2. Failure to keep this unit clean from mineral deposits may affect operation of this unit.
3. Customer failure to follow these instructions may void the warranty.

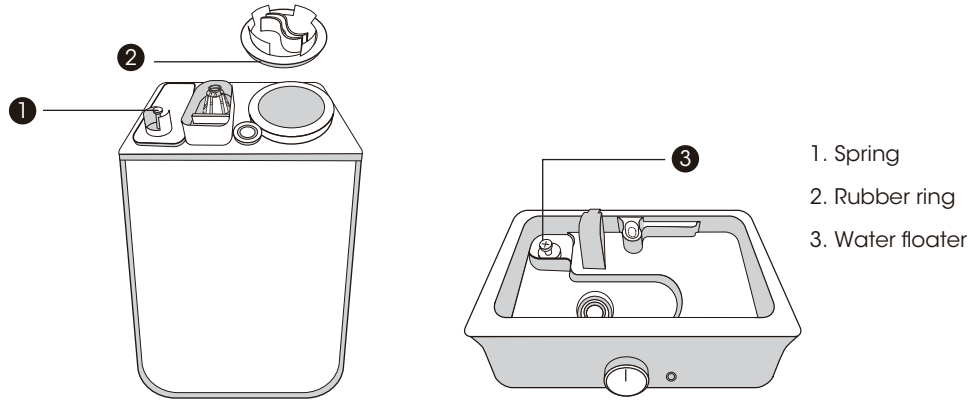

Problem	Possible Cause	Solution
Failed to turn on the unit.	Unit not plugged in.	Ensure unit is properly plugged in.
	No power from power outlet.	Try another power outlet.
Waterless indicator is constantly on.	No water in the water reservoir.	Ensure the 1 spring is secured properly to the tank allowing water to pass through to the base.
	3 Water floater get stuck.	Adjust the 3 water floater to a horizontal position and make sure it can rise up with water .

The unit is on but no mist or little mist is produced.	Not enough water inside the tank.	Refill and reinstall the water tank.
	Mist level is set too low.	Adjust to larger mist output.
	The base might be overfilled.	Remove the tank, empty the base and place back the filled tank on the empty base.
	Mineral buildup on atomizer.	Put your hand towards the nozzle and feel if there is air coming out. If yes, clean the water scale on the atomizer as instructed(p10).
Tank leakage.	Tank may be damaged.	Check for possible cracks in the tank. Ask for a replacement if it is damaged.
	Tank cap is not tightened securely.	Tighten the tank cap.
	2 Rubber ring was not installed on tank cap.	Check the tank cap for rubber ring, contact us if any is missing.
	1 Spring get stuck.	Ensure the 1 spring is secured properly to the tank allowing water to pass through to the base.
Mist height is low, damping surrounding desk or floor. Condensation forms around humidifier or on windows and walls.	Mist level is set too high for the room size.	1. Check if the room is too humid, adjust to lower mist output. 2. Open door and windows, or change to a larger room.
	Air inlet is blocked.	Humidifier should be placed on a hard flat surface, 2 feet above the floor, 12 inches away from the wall. Point mist outlet away from wall or window.
	Low indoor temperature leads to liquefaction.	Raise the room temperature to 25°C/77°F.

Poor humidification.	Mist level is set too low for the room size.	1-1. Adjust to maximum mist output. 1-2. Close door or windows to reduce air ventilation, or change to a smaller room.
	Air inlet is blocked.	Humidifier should be placed on a hard flat surface, 2 feet above the floor, 12 inches away from the wall.
	Low indoor temperature leads to liquefaction.	Raise the room temperature to 25°C/77°F.
White dust appears / Black coating in the base flakes off.	Tap water may contain too much minerals.	Replace with filtered or distilled water or use with a TaoTronics Demineralization Cartridge.
Strange odor.	Unit needs to be cleaned.	Clean the humidifier as instructed.
		Leave the empty water tank open in a cool place for 12 hours without the water tank cap attached.
Strange water noise.	Water is going down to the water reservoir.	This is normal while it is working.
Humidifier is getting too hot.	Unit works long hours.	Power off and place in a well-ventilated place for 10 minutes.

WARRANTY

This product is covered with TaoTronics product and labor warranty for 12 months from the date of its original purchase. You will be given a warranty extension of 18 months if the product is registered on our website (www.taotronics.com).

Any defective part will be, at the discretion of **SUNVALLEYTEK INTERNATIONAL INC.**, repaired or replaced at no charge if the appliance has not been tampered with and has been used according to these printed directions.

If any problems occur, please contact TaoTronics support (support@taotronics.com) immediately to launch a warranty claim. Specify model number and your Amazon order number. Our Consumer Service Representative will respond within 1 business day, advise you how to correct the problem yourself, or instruct you on how to return the defective unit back to us for repair or replacement.

We can only provide after sales service for products that are sold by TaoTronics or TaoTronics authorized retailers and distributors. If you have purchased your unit from a different place, please contact your seller for return and warranty issues.

CONTACT / TAOTRONICS CUSTOMER CARE

PLEASE CONTACT US BEFORE RETURNING THIS PRODUCT TO THE STORE.
EMAIL TAOTRONICS CUSTOMER CARE FOR PROBLEMS AND QUESTIONS.
WE WILL RESPOND WITHIN 1 BUSINESS DAY.

Sunvalleytek USA, Inc.

Address: 46724 Lakeview Blvd, Fremont, CA 94538

E-mail: support@taotronics.com(US)

support.ca@taotronics.com(CA)

support.uk@taotronics.com(UK)

Tel: 1-888-456-8468 (Monday-Friday: 9:00 – 17:00 PST)

Website: www.taotronics.com

www.taotronics.com

