



BH-USA

EVERYTHING FOR YOUR DOCK & PIER

EQUIPMENT GUIDE

84002PR RVSD 4/2019

ACCESS MORE **INFORMATION** & **ORDER** ONLINE AT BH-USA.COM

WAYS TO SHOP!



**Shop By
Catalog**

Request Yours Online or by Phone



800-259-8715

Mon-Fri 8-5 CT



**Shop Our Site
24/7**

WWW.BH-USA.COM

BH-USA is a fulfillment center and does not have any type of show room or store. We encourage you to order Online or call our customer service to place orders. Walk-In orders with no advanced notice cannot be filled immediately and will be processed in order taken.

STAY CONNECTED!



THIS GUIDE IS INTENDED FOR THE END USER.

Rvsd. 9-2017



BH-USA Warranty Information and Procedures.....	1
Helpful Tips on Components of Boathouse Lift Installations.....	2-5
Helpful Tips on Flat Plate Hoist Maintenance and Installation.....	6-7
A-Drive/Enclosed Worm Gear Reducer and Installation.....	8
Helpful Tips on Boat Lift Motors.....	9-12

► WIRING DIAGRAMS - MOTORS TO SWITCH

Elite Motors - Painted .75 HP , 1 HP, 1.5 HP	120, 240 VAC.....	11
Elite Motors - Stainless .75 HP , 1 HP, 1.5 HP	120, 240 VAC.....	12
Standard T# .75 HP , 1 HP, 1.5 HP	120, 240 VAC.....	13
Standard Colored Motor .75 HP , 1 HP, 1.5 HP	120, 240 VAC.....	14
Marathon Motor/GE .75 HP , 1 HP	120, 240 VAC.....	15
Leeson Motor/ACE .75 HP , 1 HP, 1.5 HP	120, 240 VAC.....	16
Regal/A.O.Smith Motor .75 HP , 1 HP	120, 240 VAC.....	17
Baldor .75 HP , 1 HP	120, 240 VAC.....	18
Century AC/A.O.Smith .75 HP , 1 HP	120, 240 VAC.....	19 - 20
Century Magnetek .75 HP , 1 HP	120, 240 VAC.....	21
Emerson .75 HP , 1 HP	120, 240 VAC.....	22
NEMA Motor Information.....		23

Helpful Tips on Switches.....	24-26
Trouble Shooting.....	27-28
FAQ'S/Records.....	29-30
Warranty.....	31-32

Attention:

If you are wiring a switch or motor to an existing switch or motor and using the 2019 wiring guide, you will have to rewire the existing equipment to match the 2019 wiring guide in order for the new items to work.

BOTH THE MOTOR AND THE SWITCH NEED TO BE REWIRED TO MATCH THE 2019 BH-USA EQUIPMENT GUIDE

BH-USA assumes no responsibility or liability for installations and/or improper use of the equipment. This guide is intended to be used as a reference and general guideline only. **BH-USA** is not responsible for the design, construction or installation of docks, piers or lifts.

The following warranty applies to all components and hoists manufactured by **BH-USA**. Warranty applies to manufacturing defects and/or failures due to design or fabrication. Replacement parts, a repaired unit, or a new unit will be supplied at no charge at the discretion of **BH-USA**. This does NOT include labor or freight

- ▶ Gearplate Assembly (GPA) - Life Time
- ▶ Enclosed Gears - Two Years
- ▶ Motors - One Year
- ▶ Switch & GFCI - 30 Days

THE FOLLOWING ARE NOT WARRANTED BUT ARE MANUFACTURED & REGULATED BY SPECIFIC INDUSTRY STANDARDS:

- ✓ SLINGS AND CRADLES
- ✓ STRUCTURAL STEEL
- ✓ FASTENERS
- ✓ CABLE AND RIGGING
- ✓ MACHINED PARTS, I.E. GEARS

- ▶ Warranty is void if unit is improperly installed, maintained, greased or alterations are made to the original manufacturer's design.
- ▶ Warranty is predicated on the equipment being inspected and serviced on an annual basis by a qualified technician.
- ▶ Warranty applies to original owner.
- ▶ Warranty is VOID if transfer of ownership.

BH-USA RETURNS

2368 FM 2087N
LONGVIEW, TX
75603

Call prior to returning equipment for *RMA (Returned Merchandise Authorization)*. **ALL** Returns must have *RMA number clearly listed on return box*. WE ARE NOT RESPONSIBLE FOR DAMAGES INCURRED IN SHIPMENT. *Customer is responsible for return shipping costs*. Once item is received, **BH-USA** will deem item returned warranted within *two weeks*. **BH-USA** reserves the right to determine whether warranted items will be repaired or replaced.

WARRANTY PROCEDURE

Please review this publication before attempting a return to BH-USA for warranty consideration.

DO NOT return the product to the store where it was purchased or to the installer/dealer.

Call **BH-USACUSTOMER SUPPORT 800-259-8715**

Returned merchandise must be sent via ground and not through the U.S. Postal Service.

WARRANTIES DEPEND UPON AN ANNUAL PROFESSIONAL INSPECTION BY A QUALIFIED TECHNICIAN.

Although BH-USA does not endorse any builder or installer, a **BUILDER LOCATOR'S** provided on the BH-USA website, listing builder's found to be reliable and knowledgeable using BH-USA equipment.

BH-USA.COM /BUILDER-LOCATOR

WHILE EVERY CARE HAS BEEN TAKEN TO AVOID MISTAKES, BH-USA WILL NOT ACCEPT LIABILITY FOR ANY ERRORS, MISPRINTS, TYPOGRAPHICAL ERRORS, OMISSIONS OR MISINTERPRETATIONS OF THE BH-USA OVERHEAD LIFT GUIDE - THE BH-USA EQUIPMENT GUIDE.

A boathouse lift uses a hoist, cables, and pulleys to lift a boat. The boat hoist turns a pipe upon which the cable is wound, and the cable extends to the sides of the boathouse, travels down via pulleys, and then attaches to either slings or a cradle.

APPROX. WEIGHTS

Fuel Weight =
Gallons x 6 lb

Tuna Towers or Wake
Board Towers =
+/- 400 lbs

Typical Steel Cradles :
5" I-beams = 10lbs
per foot

6" I-beams = 12.5 lbs per foot
2.2.1/4" Angle = 3.29 lbs per foot
2 x 8' Lumber =
Approx. 2 lbs per foot

▶ BOATHOUSE CONSTRUCTION

Although some are made with steel, most boathouses are constructed of wood and designed with a roof to protect boats from the weather. A *boathouse lift* attaches to the roof joists of the boathouse. Typical installations **require three** joists for mounting. **One joist** is dedicated to the boat hoist-the gear and motor unit which *turns the pipe*. The *other two joists support the pipe and pulleys* that carry the cable down to the boat. For added strength, wood constructed boathouses usually **double up the joists** to carry the load of the boat. Mounting brackets are through-bolted to the roof joist For boathouses built with steel, joists are boxed, steel beams and typical installation brackets are used. If the joists are steel I-beams, special I-beam brackets are used which clamp to the I-beam so *no drilling is necessary*.

CAUTION: Drilling through the side of an I-beam destroys its structural integrity

▶ SLINGS AND CRADLES

Boathouse lifts use either polyester slings or steel cradles to lift a boat. Cradles are made up of two steel I-beams that have attachment points on the ends for cables. They include brackets for holding carpeted, bunk boards that the boat rests upon. Boat cradles can be set-up for different hull shapes such as V-hull or flat bottom boats. Pontoon brackets are also available which allow for a pair of bunk boards on each side of the cradle for both pontoons. Cradles work well for in-board boats and work best with four posters but require more depth in the slip.

▶ SLING / CRADLE SPACING

Setting-up spacing between slings or cradle beams is important for proper support of the boat and proper functioning of the lift. The center of gravity of the boat must be in the middle, either between the two slings or the cradle beams.

First, set the rear sling or cradle beam near the rear of the hull but make sure it clears the motor and is properly supporting the boat. Then calculate the distance from that rear support to the center of gravity of your boat. The rear beam or sling should not be any more than **18"** from Stern of the boat. The boat's Stern can not hang out any further than this or they is a risk of cable breaking. Since the center of gravity is also the center of your slings or cradle, use that measurement to find the position for the front sling or cradle beam. The next support should be no more than **12 feet forward** on boats *under 34 feet* and **14 feet forward** for *larger boats up to 39 feet*. If it is too far forward and the hull is starting to slope up then re-adjust the position of your supports. Finally, double check everything to make sure the center of gravity of the boat is centered on the lift and that the support of the boat's hull is sufficient.

When determining the overall weight of the load a hoist must lift, remember to include the dry weight of the boat, weight of the fuel, gear such as coolers, skis, tuna or wake board towers, etc. PLUS the weight of the boat cradle.

CAUTION
BH-USA IS A MANUFACTURER ONLY

While there are many notable & qualified professional lift installers, there is no governing or licensing agency that regulates boat house installations. BH-USA assumes no liability for the installation of your lift. End users should familiarize themselves with the basics of an overhead lift and its design, to enable them to determine if a proper installation has been completed. BH-USA warranties equipment based on proper installation and maintenance the strict following

▶ HOISTS

A hoist should **NEVER** be used to lift human beings. Hoists are not designed, nor intended to lift human beings, or to lift loads over areas where humans might be. **NEVER** use this hoist for any other application other than the one for which it is designed.

A boat hoist is an electric drive unit that is part of a lift. It torques the drive pipe and provide power to the lift. A flat plate hoist, using an electric motor to drive a worm reduction, is one of the most common types. This type hoist drives a pipe the length of the lift, upon which the cable wraps.

A flat plate hoist **IS NOT** a load bearing unit.

Hoists capacities range from around *3000 lbs up to 8500 lbs* when wrapped on a standard sized pipe. Hoist capacities are based upon the differences in materials with which the components are manufactured, the power rating of the motor used, and the gear ratio. **No matter what size motor used, your gear can only lift the load for which it is rated.**

The factory rating on BH-USA flat plate hoists use a **5 to 1 ratio** from motor to pulley and a **2-3/8"** Outer diameter pipe for the cable. All BH-USA gear plates have a rating which can be found on the serialized label located on either the front or back of the gear plate.

REMEMBER: The lifting capacity of your hoist/lift is only as high as the weakest rated component used. **Altering ratios of a BH-USA gear plate voids the lifetime GPA warranty.**

▶ INSTALLATION STYLES

The most common boathouse lift installation uses a single pipe lengthwise in the center of the boathouse. Cables extend across, in either direction, to four pulleys and then down to the sling or cradle. Some lifts may be set-up with the pipe all the way on one side of the boathouse and two cables extending across the boathouse to pulleys on the other side, while the other two cables go down directly from the pipe. These lifts typically cannot lift as much weight because of the opposing forces of the cables.

Some boathouse lifts use a two-pipe configuration with separate pipes on each side of the boathouse. ***This arrangement requires two boat hoists (drives) and will lift more weight. (See Appendix A - BH-USA Overhead Lift Guide for more information)***

▶ COMPOUNDING

The simplest method for building a boathouse lift that can lift more weight is to use compounding. Compounding uses pulleys to lessen the load on the hoist. Pulleys are attached to the slings or the cradle and then the cable is routed back up to the top of the boathouse where it is dead-ended. This cuts the amount of weight being lifted by the hoist, in half, but it also reduces the speed of the boathouse lift by the same amount. When using compounding to upgrade an existing lift, be sure that the boathouse and the cradle can support the extra load.

Compounding can increase the lifting capacity but significantly reduces them speed of the lift.

CAUTION

BH-USA IS A MANUFACTURER ONLY

While there are many notable and qualified professional lift installers, there is no governing or licensing agency that regulates boathouse installations. BH-USA assumes no liability for the installation of your lift. End users should familiarize themselves with the basics of a lift and its design to enable them to determine if a proper installation has been completed. BH-USA warranties equipment based on proper installation

WARNING

NEVER **REMOVE** OR **DISARM** A BUILT-IN GROUND FAULT CIRCUIT INTERRUPTER (GFCI) ON A POWER CORD IF ONE IS PRESENT. **THE GFCI PROVIDES PROTECTION AGAINST CERTAIN TYPES OF ELECTRICAL SHOCK.** ELECTRICAL EQUIPMENT AROUND WATER SHOULD NOT BE USED UNLESS GFCI PROTECTED.

NEVER TOUCH PLUGS WITH WET HANDS.

WHEN SERVICING ELECTRICAL EQUIPMENT, REPLACE THE GFCI WITH AN EQUIVALENT GFCI DEVICE ONLY.

CAUTION:

Never attempt to hang a switch from the boat hoist

▶ SWITCHES

Drum switches are used to turn the hoist on and off. BH-USA switches have holes drilled for proper mounting. Mounting the switch incorrectly may cause malfunctions. BH-USA typically carries two types of switches. *Maintain switches (also know as Lock-On) will stay in position until manually turned off.* BH-USA also carries Spring switches (also referred to as Momentary). These types of switches require the user hold the handle in the up or down position to lift or lower the boat. The switch will turn itself off when pressure is released from handle. BH-USA carries the Bremas brand switch. They feature durable housings with extended handles for easy grip and wiring directions that work with most brands of boat hoist motors.

For your safety, BH-USA only uses electrical components that are UL, CE or NEMA compliant in all hoist electrical systems.

▶ GFCI'S (GROUND FAULT CIRCUIT INTERRUPTERS)

The GFCI is designed to protect from severe or fatal electrical shock and is located in the cord that plugs into the outlet. It monitors electricity flowing in a circuit, senses any differing or loss of current, and quickly switches off power to the circuit. BH-USA's motor technicians ALWAYS test the GFCI's in all motors wired from BH-USA. If you have a BH-USA hoist and the GFCI is not present it is safe to assume that the motor was not wired by BH-USA, or that your installer may have removed it. In this case it is important to have a certified electrician check the overall system before using the hoist. If a GFCI keeps shutting your system down, it is doing its job and you should have a certified electrician check for a potentially dangerous voltage leak. Never plug a GFCI into another GFCI.

▶ WIRELESS REMOTES

Wireless remotes are very convenient because they enable you to lower the lift when bringing the boat in, allowing for changes in water levels. A remote control box replaces the manual switch and controls the motor, and it has manual controls as well. Wireless transmitters are available. Remotes can be purchased with an automatic stop that has a pre-set "up position" and a pre-set "down position" for one-touch operation.

BH-USA recommends Gem Remotes which can be purchased at BH-USA.com. BH-USA supplies a hardened GR5 bolt with all hoists and A-drives, to attach the drive pipe to the hoist. It is the end-users responsibility to ensure that the installer did use the GR5 bolt supplied by BH-USA, using a weaker grade bolt can cause the weaker bolt to fail and drop the boat.

CAUTION CHECK YOUR VOLTAGE

In most cases low voltage will not be detected until the load is on the hoist. Have an installer lift the boat completely out of the water to ensure low voltage is not a problem. Inexpensive volt meters and testers are available at BH-USA.com, and are simple to use. Lower the boat into the water, plug the volt meter into the same outlet as the hoist motor, turn the hoist on to lift and watch the voltage in real time. If at any point the voltage drops below 110V or 220V (for 220 operation)

then you have low voltage and this will eventually damage the motor.

DO NOT CONTINUE TO USE THE HOIST IF YOU HAVE LOW VOLTAGE. REFER TO THE WIRE REQUIREMENTS CHART IN THIS GUIDE.

- ✓ UNIT IS NOT LIFTING
- ✓ UNIT "SQUEALS"
- ✓ GEAR OR BACK PLATE BEARING BREAKS
- ✓ METAL SHAVINGS ARE COMING FROM THE WORM HOUSING
- ✓ UNIT FREEZES OR LOCKS UP WHEN TURNED BY HAND.

✓ **Correct Installation**

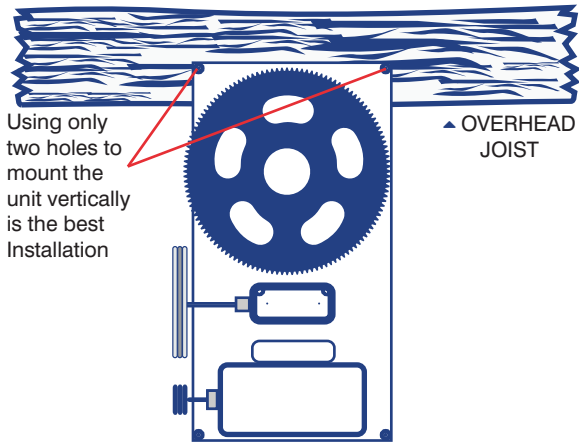

✓ **Acceptable Installation**

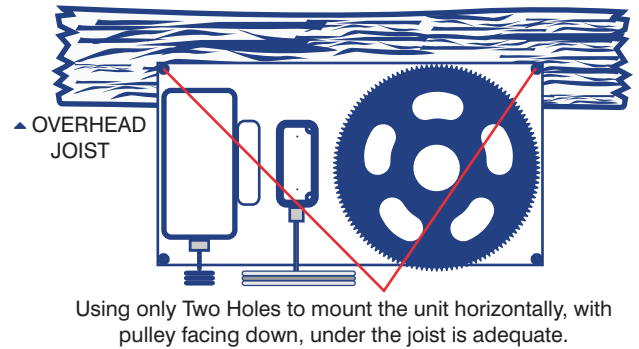

✗ **Incorrect Installation**

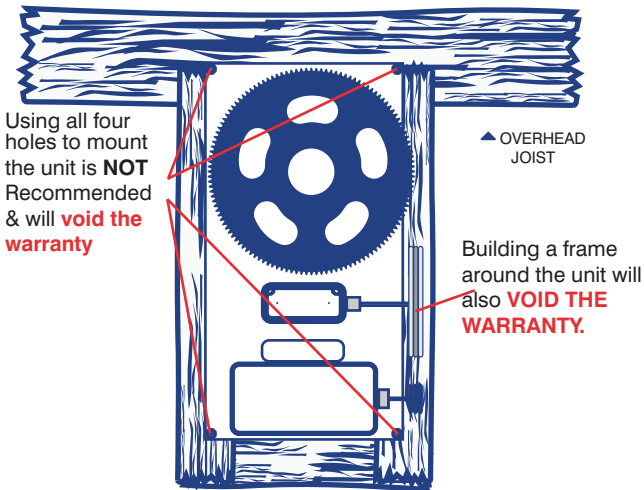

Using Two Holes to mount the unit horizontally on top of the joist, with pulley facing up, is **NOT** Recommended and will **VOID THE WARRANTY**

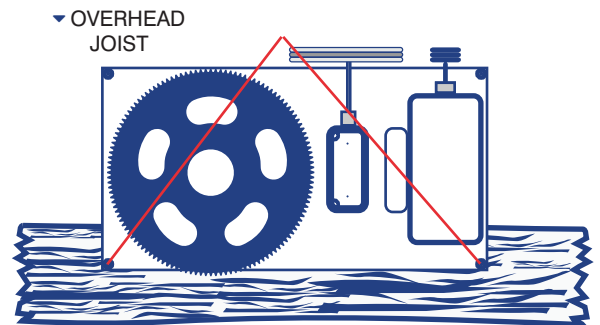

✗ **Incorrect Installation**

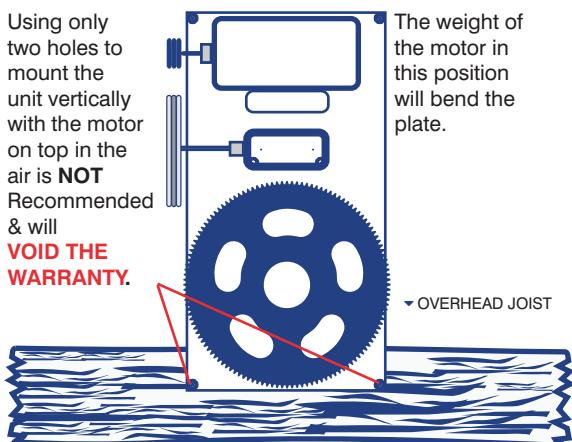

✗ **Incorrect Installation**

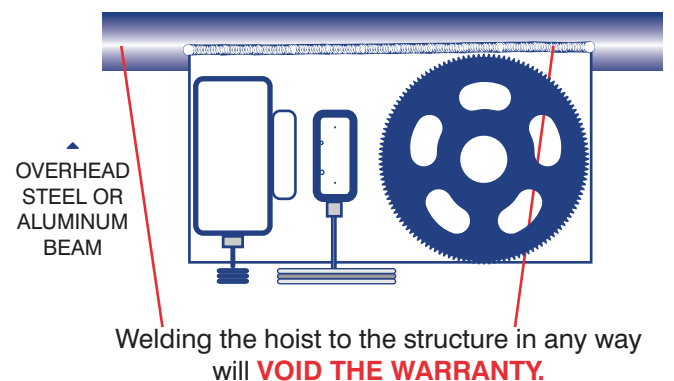

✗ **Incorrect Installation**

BEFORE FIRST USE - UNPACK HOIST & CHECK EQUIPMENT

- ✓ **Keep a service record.** Warranties depend on annual professional inspections and proper maintenance.
- ✓ Grease the hoist with **BH-USA grease** and *run the lift up and down without the boat to ensure proper distribution to all mechanical parts.* *
- ✓ **Tighten all set screws.** If mounting vertically, apply Loctite or a similar product, to the set screws to avoid pulleys from slipping due to loosened screws.
- ✓ **Check back plate bearing** and confirm that the snap rings are seated and secure.
- ✓ **Check the drive belt,** When properly mounted, the 2" pulley should line-up with the 10" pulley and the belt should move no more than 1/2" when pressed. A belt that is too tight will cause the motor shaft to break. Motor must be mounted straight to allow pulleys to line-up. Failing to do this will affect the rating of the hoist. (See diagram below)

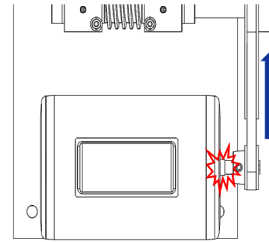
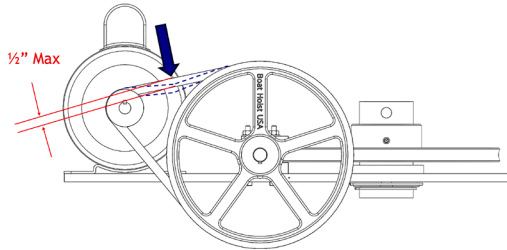

- ✓ Follow the arrow on the gear and be sure it is turning in the right direction as you lift the boat. The arrow **tells the end-user what side bushing the gear presses against**
- ✓ Run the hoist a minimum of ten cycles before any load is placed on it, known as the **"break-in period"**. Hoists not properly broken-in may be permanently damaged causing squealing, typically in the downward cycle. *Always allow the motor to cool properly after each cycle.*
- ✓ Inspect for anything that could put **extra stress** on the gear.
- ✓ Check weight being lifted to rated capacity. (See page 2 for help determining lifting capacity.)

GREASING THE HOIST

Flat plate hoists are **NOT** greased at the factory to prepare them for use. BH-USA Hoists must be properly greased before use, and re-greased after every 20 cycles. Heavy rain will also wash grease off and require the hoist to be re-greased.



*BH-USA Grease can be ordered online at

BH-USA.COM

CORRECTLY GREASING THE HOIST

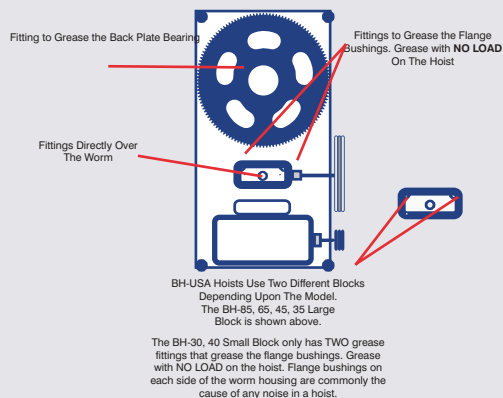

IMPORTANT GREASE POINTS ON THE BH-USA GEAR PLATE

- ▶ **BACK PLATE BEARING FITTING-** Found on the hub of the 96-tooth worm gear; pump grease into the fitting then rotate the gear a quarter turn. Repeat this four times until the gear has gone a full revolution and is completely lubricated.
- ▶ **FITTING DIRECTLY OVER THE WORM -** This fitting can be greased with the load on the hoist. Grease then rotate the 96-tooth gear a quarter turn and repeat. Use a paint brush to coat the gear completely.
- ▶ **FLANGE BUSHINGS - ONE ON EACH SIDE OF THE WORM HOUSING -** These fittings are commonly the cause of any noise in a hoist. With NO LOAD on the hoist, use a mallet to gently tap the shaft to the left, then pump grease into the far grease fitting. Run the hoist one complete cycle and then repeat. If there is a load on the hoist the worm pressure will not be released from the flange bushing and grease will not penetrate into where it should:

**See page 2 for help determining lifting capacity.

COMMON REASONS THAT CAUSE PLATES TO SQUEAL OR “SCREAM”

▶ IN BOTH DIRECTION

Hoist is not plumb or straight, that is, the back plate has bowed or is bent. The flat plate hoist back plate must be completely flat. Check the installation on flat plate hoists on **Page 5** to be sure it is installed correctly. If the installation is correct, try slightly loosening the bolts. If the beam that the plate is bolted to is not straight, then as the bolts are tightened the back plate could bend and form to the beams. If one side is loosened and the plate follows the nut then this is the issue. Putting a direct load on the hoist will also cause it to “scream” when lifting, in both directions.

▶ SQUEALS GOING DOWN ONLY

Flange bushing inside the worm housing needs to be greased. This sound is caused when the flange bushing inside the housing is bare and has no lubrication or grease. If the hoist is new, and makes this noise from the start, it could mean that the worm has a “burr” or rough spot that is being pressed against the flange bushing. Take the load off of the hoist and tap the end of the shaft to release the pressure of the worm to the flange bushing, and grease very generously. You might have to replace the worm housing if the hoist is older or greasing does not help. If this is a brand new hoist and grease doesn't help, contact BH-USA.

▶ MAINTAINING YOUR FLAT PLATE HOIST

Never attempt to weld a hoist to the structure. The pipe should move freely in and out of the unit sleeve, if it does not, the unit is in a bind and will need to be re-installed and aligned. Properly grease the unit after each use. Do not operate the unit after a lifting cycle, for at least *3 to 4 minutes*. Always use two of the four bolt holes provided, drilling holes in the plate can warp the plate and void the warranty. Changing the diameter of the lifting pipe or any of the pulleys will alter the hoists' rating capabilities. Only use actual boat hoist motors with an RPM of 1750 or less.

CAUTION

DON'T VOID THE FLAT PLATE HOIST WARRANTY

The following **WILL** void warranty and cause permanent damage to the hoist: **WELDING** hoist to a steel or aluminum beam; Using one hoist to lift front of boat and one to lift the back of the boat; Welding any part of the lift to the structure. Open gear, flat plate systems, will make noise, leave metal shavings or boil grease off when placed in overloaded conditions installed incorrectly.

The enclosed A-Drive conceals all these characteristics, therefore we recommend on each installation that the voltage drop be checked under load. Determine the voltage at the service panel. Then check the voltage across L-1 and L-2 on each motor while lifting the load. The drop must not exceed 4%. If the drop is more than 4%, the problem must be addressed.

(ENCLOSED WORM GEAR REDUCER) OVERHEAD INSTALLATION

▶ BEFORE FIRST USE UNPACK YOUR HOIST & CHECK EQUIPMENT

- ✓ *Keep a service record.* Warranties depend on annual professional inspection and proper maintenance.
- ✓ Inspect piling alignments for anything that could put *extra stress* on the gear.
- ✓ Check weight being lifted to rated capacity.

▶ CHARACTERISTICS OF THE BH-USA WORM GEAR REDUCER

The BH-USA A-Drive is a double worm gear reducer, meaning a C-face electric motor mounts directly to the small input worm reducer, and this in turn, powers the larger reducer that has the output shaft. There is an output shaft on the larger reducer designed to accept a hardened shaft. BH-USA manufactures brackets for specific installations. The Worm Gear reducer or any other boat hoist is not designed to be load bearing.

BH-USA supplies a hardened GR5 bolt with all hoists and A-drives, to attach the drive pipe to the hoist. It is the end-users responsibility to ensure that the installer did use the GR5 bolt supplied by BH-USA, using a weaker grade bolt can cause the weaker bolt to fail and drop the boat.

- ▶ To run the cable use BH-USA Blocks.
- ▶ It is crucial that the lifting cable be between two pipe sleeves.
- ▶ Never use the A-Drive as a pipe support.
- ▶ For more lifting power or to keep the center clear of the lifting pipe BH-USA suggests a twin drive system with a hoist on both sides of the boat.

The BH-USA A-Drive can be used on the all aluminum BH-USA 4-Post lifts as an alternative to the flat-plate hoist, by using the BH-USA A-Drive Brackets.



When installing the motor to the A-Drive gearbox, ensure the motor shaft is aligned with the input. Tighten all four (4) motor mounting bolts. Check to make sure the mounting bolts remain tight. **Failure to do so could cause the shaft to break without warning.**

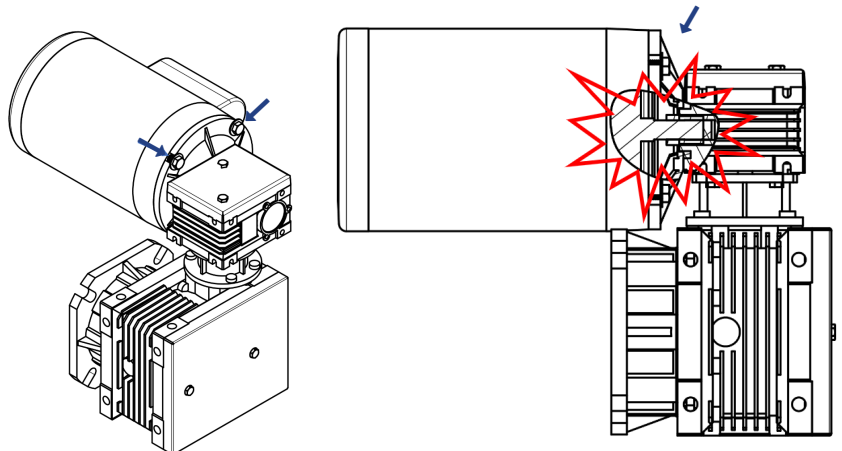

BH-USA carries the Elite, Marathon and Leeson brands of boat lift motors; C-face and 56 frame; painted and stainless steel for both fresh and saltwater lifts from 3/4 HP through 1.5HP. See *wiring diagrams for the motors and switches BH-USA sells in this manual and online at BH-USA.COM*

BH-USA can not assume responsibility nor can we help in the operation wiring or information pertaining to other equipment not supplied by BH-USA.

Boat lift motors are uniquely different than other motors. They are designed to run at maximum for a very short amount of time. A boat lift motor's vent caps are solid and not vented, to protect from insects and the elements. Because of this, boat lift motors tend to get hot very quickly. Pay attention to the maximum run times and always let your boat lift motor cool down between cycles. **Boat lift motors and hoists should never be run on a portable generator or powered with an extension cord.**

Generators do not produce enough consistent voltage to power a boat hoist motor correctly and this can cause damage to the motor. For this reason you should also never use extension cords to power your hoist or motor. The thermal protection has also been removed from the inside or the boat hoist motor, therefore if it runs hot, the wiring can melt.

▶ CAPACITORS

Improper installation of a boat hoist motor with the capacitor facing down can cause it to fill with water and can cause damage to the motor.

✓ **Correct Installation:**
Capacitor Housing Facing Up

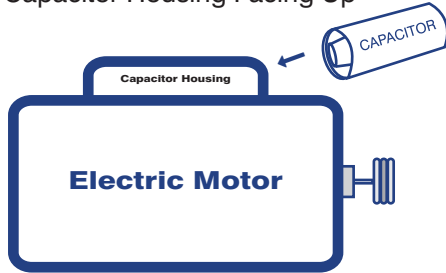

✓ **Acceptable Installation**
Capacitor Housing at Side of Motor

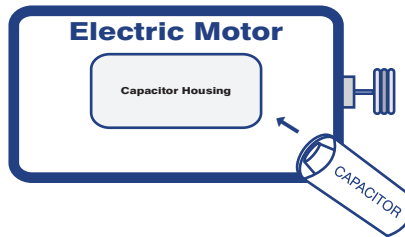

✗ **Incorrect Installation**
When Capacitor Housing is Facing Down It can fill with Water

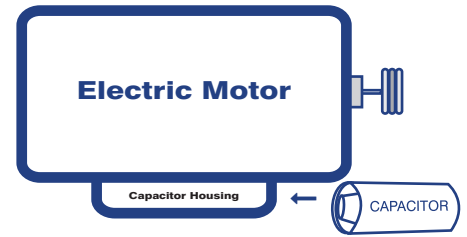

WIRE REQUIREMENTS THAT ENABLE THE BH-USA HOIST TO OPERATE CORRECTLY WHEN LIFTING STRAIGHT LINE:

# of Motors	HP	amps to run 115V	amps to run 230V	50 ft at 115V	50 ft at 230V	100 ft at 115V	100 ft at 230V	200 ft at 115V	200 ft at 230V	300 ft at 115V	300 ft at 230V	400 ft at 115V	400 ft at 230V
1	3/4	10.8	5.4	#14	#14	#10	#14	#8	#12	#6	#12	#4	#10
1	1	12.8	6.4	#12	#14	#10	#14	#6	#12	#4	#12	#4	#10
1	1.5	17.0	8.5	#12	#14	#8	#12	#6	#10	#4	#10	#2	#8
2	3/4	21.6	10.8	#10	#12	#8	#12	#4	#10	#2	#8	XX	#6
2	1	25.6	12.8	#8	#10	#8	#10	#4	#10	#2	#6	XX	#4
2	1.5	34.0	17.0	#8	#10	#6	#10	#2	#8	#0	#4	XX	#2

WIRE SIZE CHART FOR ELECTRIC MOTORS BASED ON DISTANCE FROM SERVICE TO MOTOR

# of Motors	HP	amps to run 115V	amps to run 230V	50 ft at 115V	50 ft at 230V	100 ft at 115V	100 ft at 230V	200 ft at 115V	200 ft at 230V	300 ft at 115V	300 ft at 230V	400 ft at 115V	400 ft at 230V
1	3/4	10.8	5.4	#14	#14	#10	#14	#8	#12	#6	#12	#4	#10
1	1	12.8	6.4	#12	#14	#10	#14	#6	#12	#4	#12	#4	#10
1	1.5	17.0	8.5	#12	#14	#8	#12	#6	#10	#4	#10	#2	#8
2	3/4	21.6	10.8	#10	#12	#8	#12	#4	#10	#2	#8	XX	#6
2	1	25.6	12.8	#8	#10	#8	#10	#4	#10	#2	#6	XX	#4
2	1.5	34.0	17.0	#8	#10	#6	#10	#2	#8	#0	#4	XX	#2

Water penetration in a motor or switch will void the warranty and a new motor or switch will need to be purchased.

Like most electrical components boat lift motors, switches and GFCIs are **not designed to be waterproof**. Water penetration will cause this equipment to **FAIL** and will not be covered by warranty. *Improper installation is the primary cause of water penetration.* A **CORRECTLY** installed motor or switch will not have an issue with water penetration.

▶ **STAINLESS STEEL C-FACE MOTORS WITH AN IP RATING**

C-face motors used on gear boxes that are not belt-driven, such as the BH-USA A-Drives, are designed to be in the direct outdoor environment and require no type of extra cover. These motors have an IP rating, which states that when properly installed, water (from rain) will not penetrate the motor. BH-USA's Elite Stainless Motors are rated at **IP-55**. Tests conducted on these motors with water jetted from a .25" hose have been proven to **NOT** penetrate a **correctly installed motor**.

*C-Face Stainless Steel Motor plugs may or may not have been removed before shipping. BH-USA removes the plugs opposite from the capacitor. Depending upon the installation, these may not be the holes at the **LOWEST** point on the motor and therefore could be exposed to moisture/condensation. Be sure, after the motor is installed, that the lowest plugs have been removed. They can then be used to protect and plug the other holes that may have been removed at the factory.*

An enclosed boat hoist motor will collect condensation inside the motor. As a motor runs it heats up then rapidly cools off, pulling moisture into the motor, especially in a humid atmosphere. Outdoor use motors such as the BH-USA Stainless Steel Elite has an IP55 rated housing, and can fill with water and short out the motor if condensation is not drained. **THIS IS NOT WARRANTABLE**. Motors with high IP ratings have drain holes around the end caps of the motors.

▶ **PAINTED MOTORS FOR BELT-DRIVEN HOISTS WITH A NEMA TENV RATING**

Painted, 56-Frame motors for belt-driven hoists like those sold by BH-USA are **NEMA TENV** which means they are non-vented and totally enclosed to lesson exposure to dust, dirt, insects and other solids, however they are not airtight and not protected from water or moisture. These type motors are not intended for exposed installation in the direct outdoor environment and should only be used inside boat houses or under optional, flat plate hoist covers. Proper mounting will help prevent water penetration.

CAUTION **DON'T VOID THE MOTOR WARRANTY**

Improperly installing the boat hoist motor with the capacitor facing down can cause it to fill with water. Evidence of water damage will void the warranty.

WARNING - GFCI

NEVER REMOVE OR DISARM A BUILT-IN GROUND FAULT CIRCUIT INTERRUPTER (GFCI) ON A POWER CORD IF ONE IS PRESENT. THE GFCI PROVIDES PROTECTION AGAINST CERTAIN TYPES OF ELECTRICAL SHOCK. ELECTRICAL EQUIPMENT AROUND WATER SHOULD NOT BE USED UNLESS GFCI PROTECTED. NEVER TOUCH PLUGS WITH WET HANDS. WHEN SERVICING ELECTRICAL EQUIPMENT, REPLACE THE GFCI WITH AN EQUIVALENT GFCI DEVICE ONLY.

THE FOLLOWING PROCEDURE IS FOR WIRING THE PRE-WIRED BH-USA DRUM SWITCH OR BH-USA WIRE HARNESS TO THE MOTOR. **Insure switch is wired to pg. 26**
 step by step wiring videos available at bh-usa.com & youtube for this motor.

THIS DIAGRAM ALSO COVERS CERTAIN MODELS OF: A.O.Smith

120 VAC

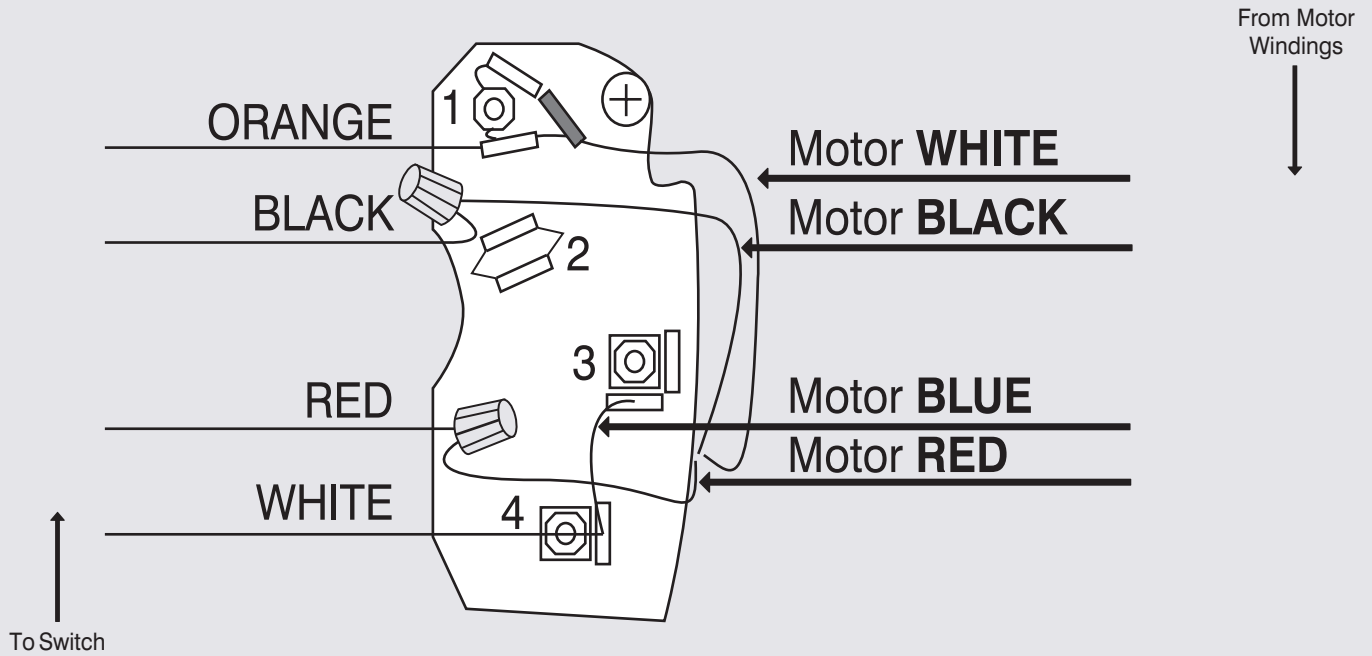

240 VAC

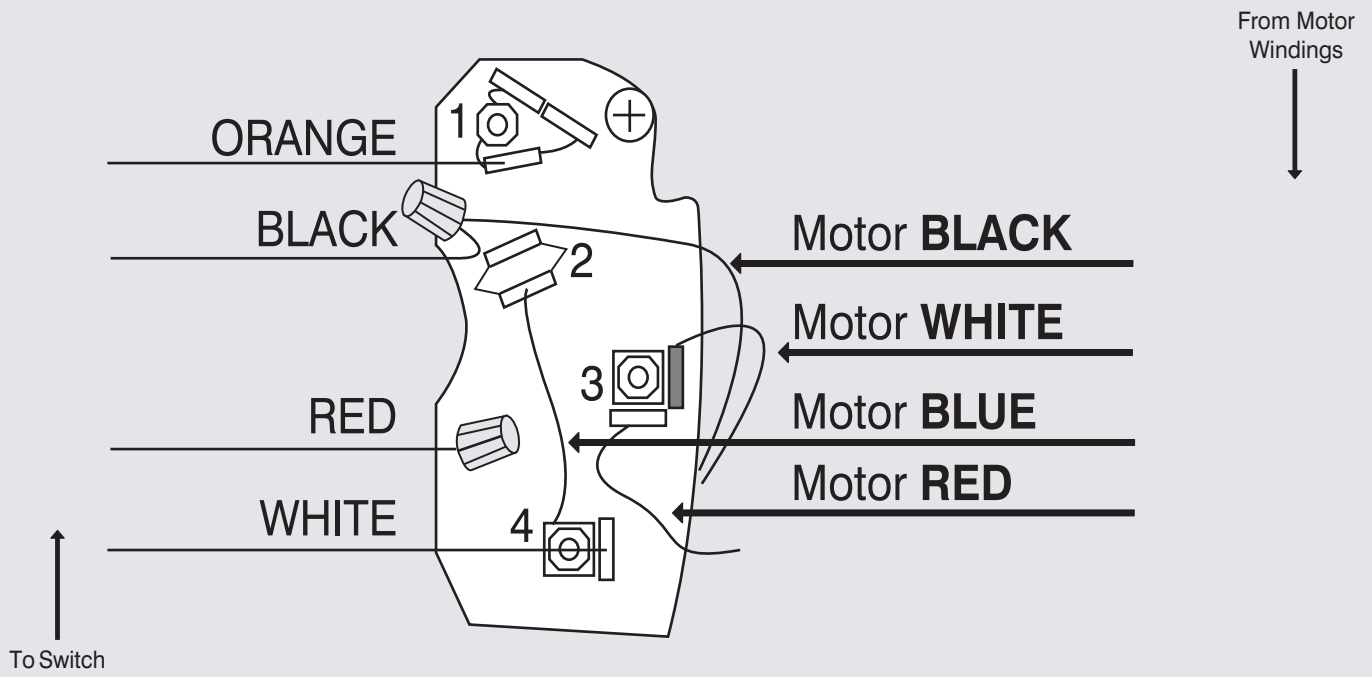

► To change motor direction, switch **Orange & White** Controller wires.

ATTENTION:
PROFESSIONAL LIFT INSTALLERS

The Elite Stainless Steel Motors were modeled after the Electra-Gear and Leeson Stainless Motors and will wire the exact same way. Use the Key for GEM Remotes use the column labeled standard colored wire, just to the right of the column used for Leeson and Regal Beloit at WWW.GEMREMOTES.COM The Elite Stainless Steel Motors are UL Controlled. If the motor doesn't work. Wire according to the information on this page and then reference the switch guide to be sure the wiring matches this guide.

THE FOLLOWING PROCEDURE IS FOR WIRING THE PRE-WIRED BH-USA DRUM SWITCH OR BH-USA WIRE HARNESS TO THE MOTOR. **Insure switch is wired to pg. 26** step by step wiring videos available at bh-usa.com & youtube for this motor.

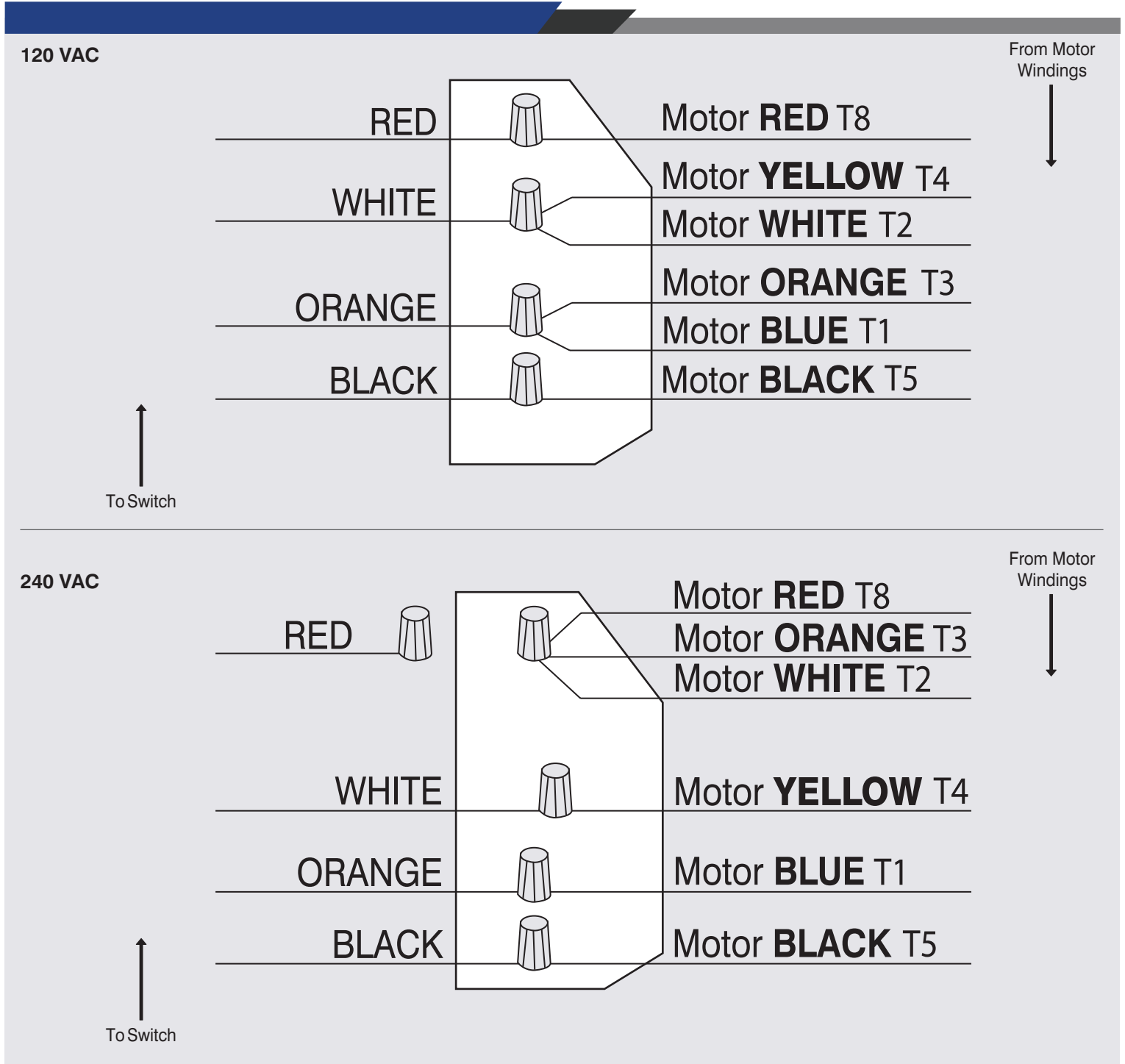

► To change motor direction, switch **Orange & White** Controller wires.

ATTENTION:

PROFESSIONAL LIFT INSTALLERS

The Elite Stainless Steel Motors were modeled after the Electra-Gear and Leeson Stainless Motors and will wire the exact same way. Use the Key for GEM Remotes use the column labeled standard colored wire, just to the right of the column used for Leeson and Regal Beloit at WWW.GEMREMOTES.COM The Elite Stainless Steel Motors are UL Controlled. If the motor doesn't work. wire according to the information on this page and then reference the switch guide to be sure the wiring matches this guide.

THE FOLLOWING PROCEDURE IS FOR WIRING THE PRE-WIRED BH-USA DRUM SWITCH OR BH-USA WIRE HARNESS TO THE MOTOR. **Insure switch is wired to pg. 26**

step by step wiring videos available at bh-usa.com & youtube for this motor.

THIS DIAGRAM ALSO COVERS CERTAIN MODELS OF: A.O.Smith, Baldor, Dayton, Deco GE, Electrogear, Emerson, Iron horse, Leeson, Lincon, Marathon, SMC, WEG & Other "T# Motors

120 VAC

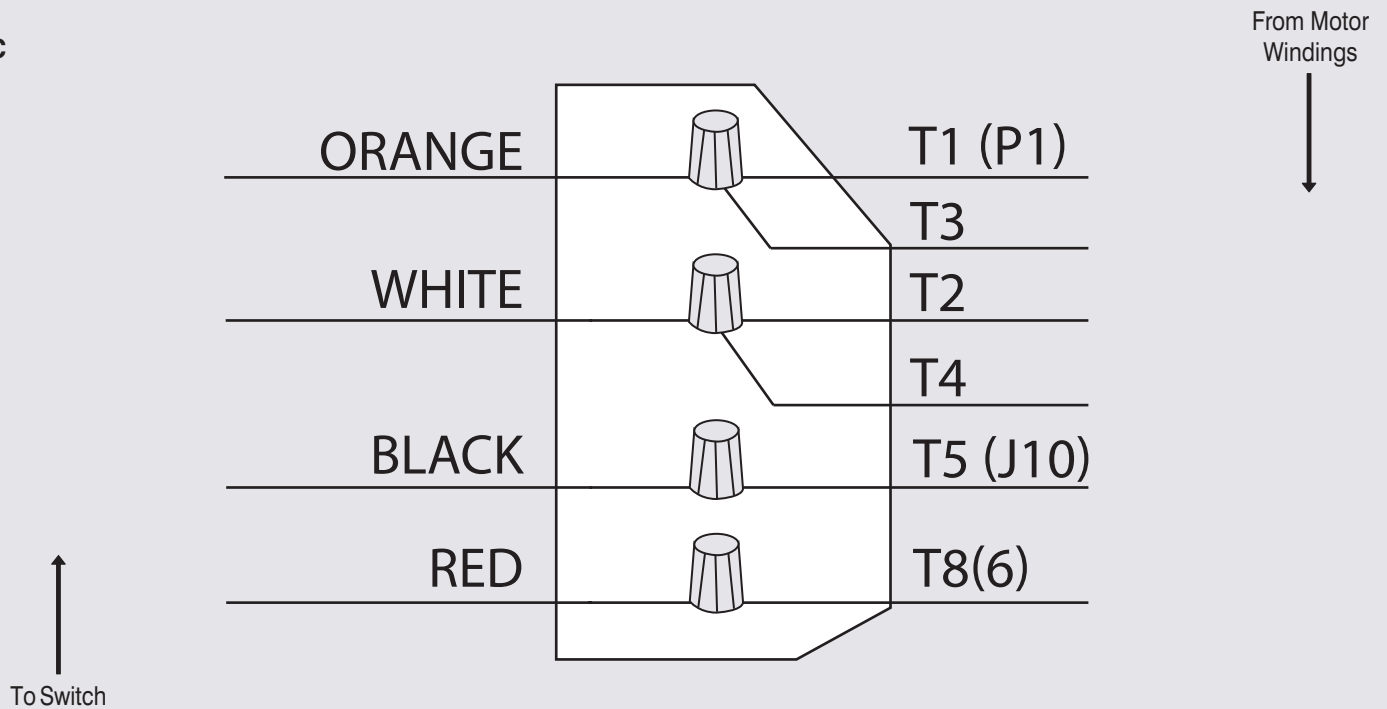

240 VAC

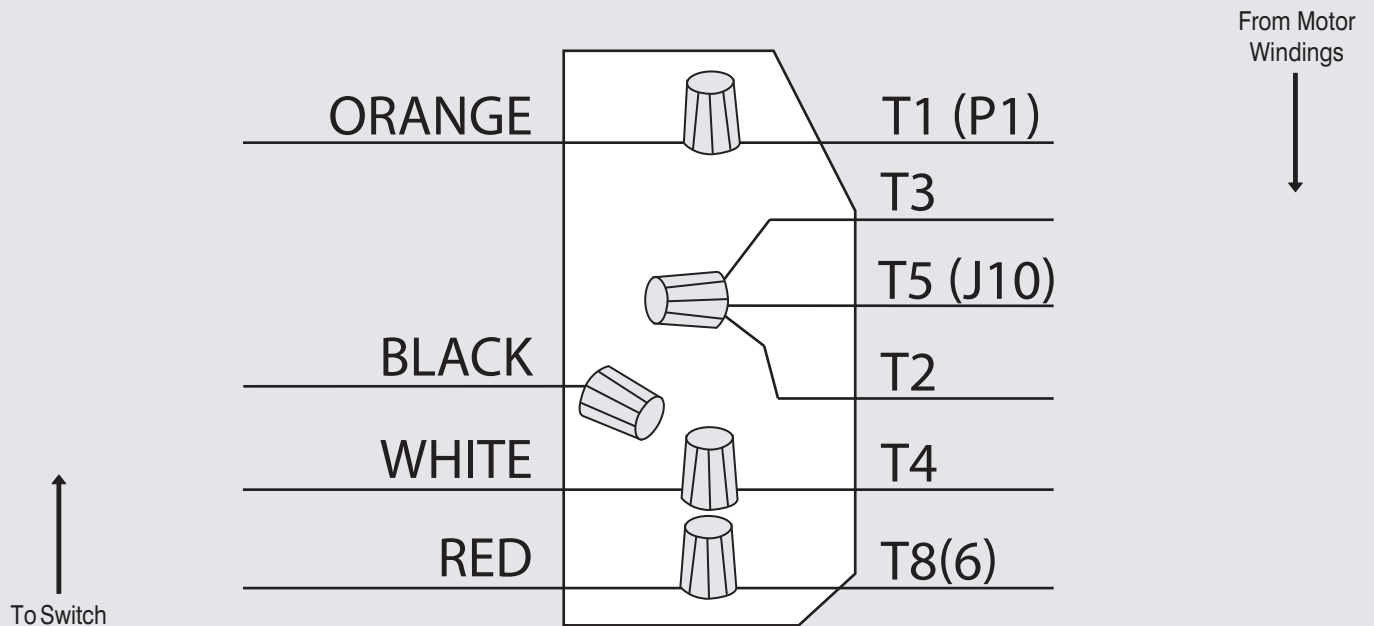

► To change motor direction, switch **Orange & White** Controller wires.

ATTENTION:
PROFESSIONAL LIFT INSTALLERS

The Elite Stainless Steel Motors were modeled after the Electra-Gear and Leeson Stainless Motors and will wire the exact same way. Use the Key for GEM Remotes use the column labeled standard colored wire, just to the right of the column used for Leeson and Regal Beloit at WWW.GEMREMOTES.COM The Elite Stainless Steel Motors are UL Controlled. If the motor doesn't work. Wire according to the information on this page and then reference the switch guide to be sure the wiring matches this guide.

THE FOLLOWING PROCEDURE IS FOR WIRING THE PRE-WIRED BH-USA DRUM SWITCH OR BH-USA WIRE HARNESS TO

THE MOTOR. **Insure switch is wired to pg. 26**

step by step wiring videos available at bh-usa.com & youtube for this motor.

THIS DIAGRAM ALSO COVERS CERTAIN MODELS OF: A.O.Smith, Baldor, Dayton, Deco GE, Electrogear, Emerson, Iron horse, Leeson, Lincon, Marathon, and Other Colored Motor Wires

120 VAC

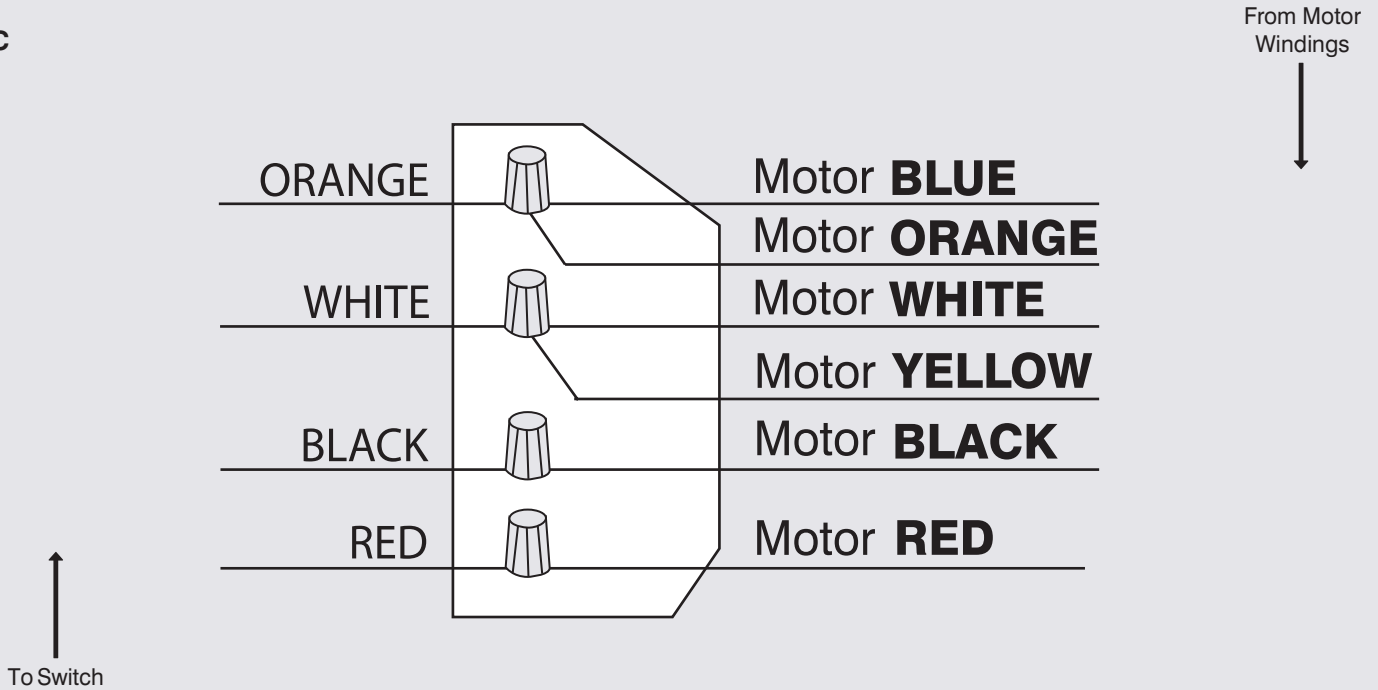

240 VAC

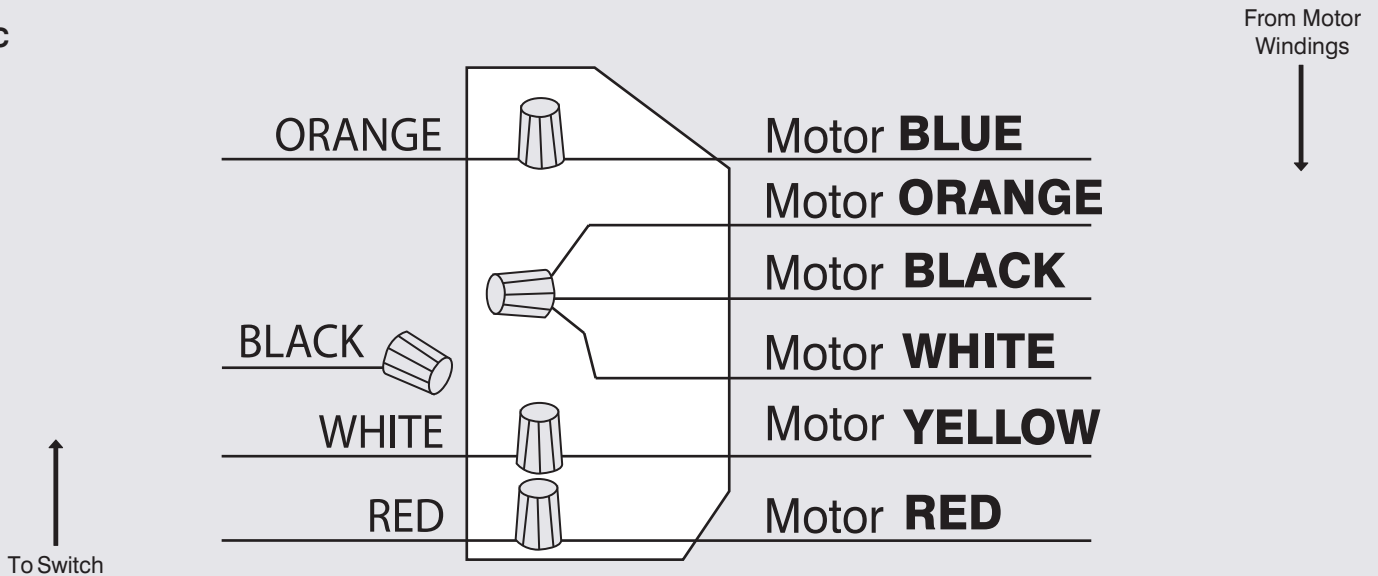

► To change motor direction, switch **Orange & White** Controller wires.

ATTENTION:
PROFESSIONAL LIFT INSTALLERS

The Elite Stainless Steel Motors were modeled after the Electra-Gear and Leeson Stainless Motors and will wire the exact same way. Use the Key for GEM Remotes use the column labeled standard colored wire, just to the right of the column used for Leeson and Regal Beloit at WWW.GEMREMOTES.COM The Elite Stainless Steel Motors are UL Controlled. If the motor doesn't work. Wire according to the information on this page and then reference the switch guide to be sure the wiring matches this guide.

THE FOLLOWING PROCEDURE IS FOR WIRING THE PRE-WIRED BH-USA DRUM SWITCH OR BH-USA WIRE HARNESS TO THE MOTOR. **Insure switch is wired to pg. 26**
 step by step wiring videos available at bh-usa.com & youtube for this motor.

THIS DIAGRAM ALSO COVERS CERTAIN MODELS OF: A.O.Smith

120 VAC

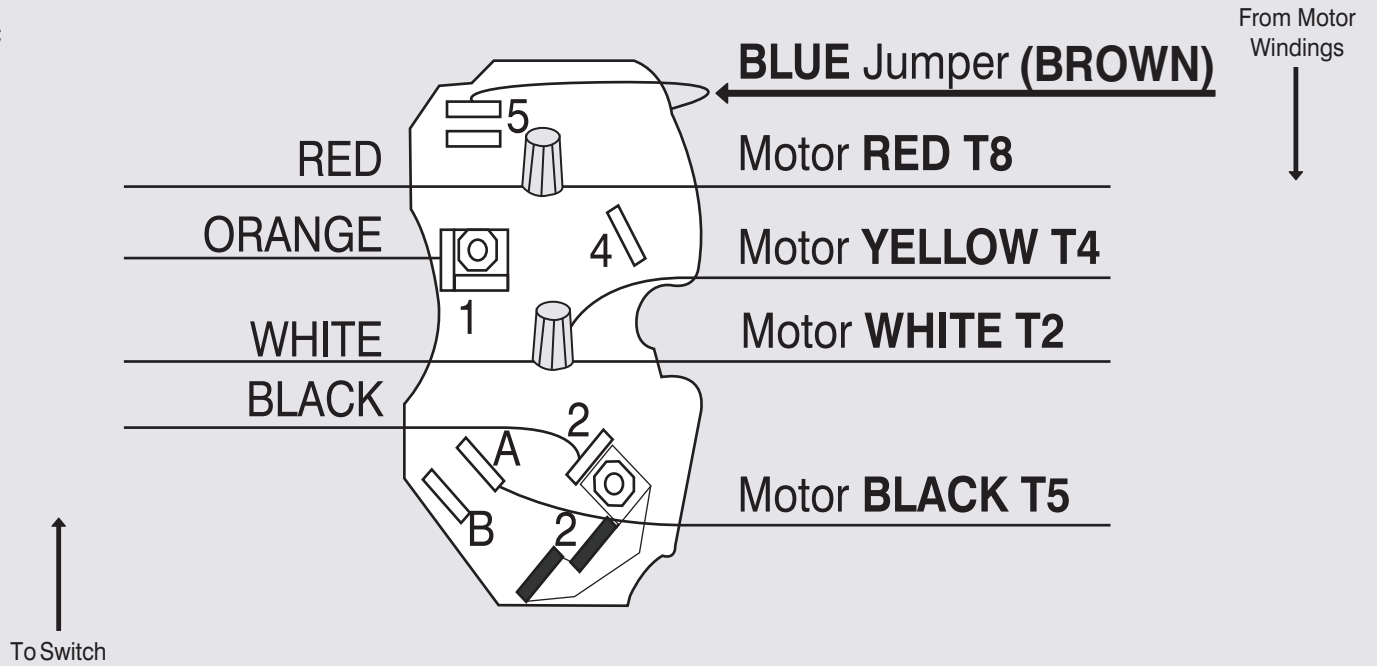

240 VAC

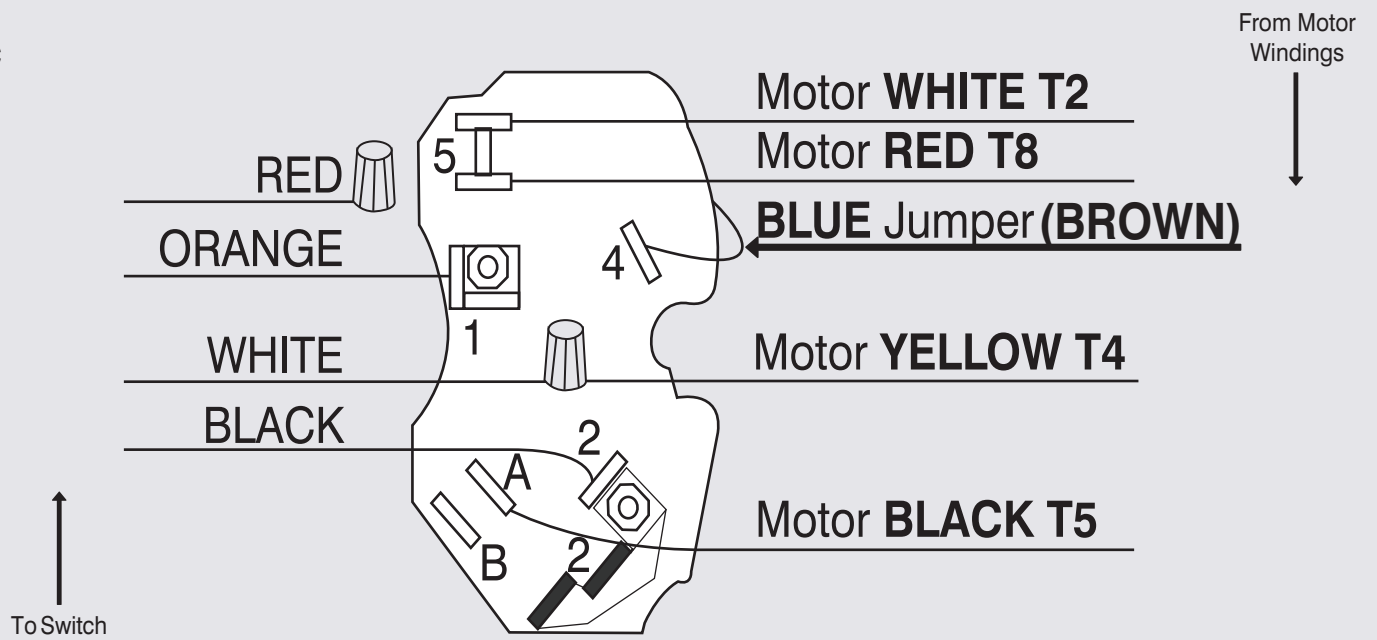

► To change motor direction, switch **Orange** & **White** Controller wires.

ATTENTION:
PROFESSIONAL LIFT INSTALLERS

The Elite Stainless Steel Motors were modeled after the Electra-Gear and Leeson Stainless Motors and will wire the exact same way. Use the Key for GEM Remotes use the column labeled standard colored wire, just to the right of the column used for Leeson and Regal Beloit at WWW.GEMREMOTES.COM The Elite Stainless Steel Motors are UL Controlled. If the motor doesn't work. Wire according to the information on this page and then reference the switch guide to be sure the wiring matches this guide.

THE FOLLOWING PROCEDURE IS FOR WIRING THE PRE-WIRED BH-USA DRUM SWITCH OR BH-USA WIRE HARNESS TO THE

MOTOR. **Insure switch is wired to pg. 26**

step by step wiring videos available at bh-usa.com & youtube for this motor.

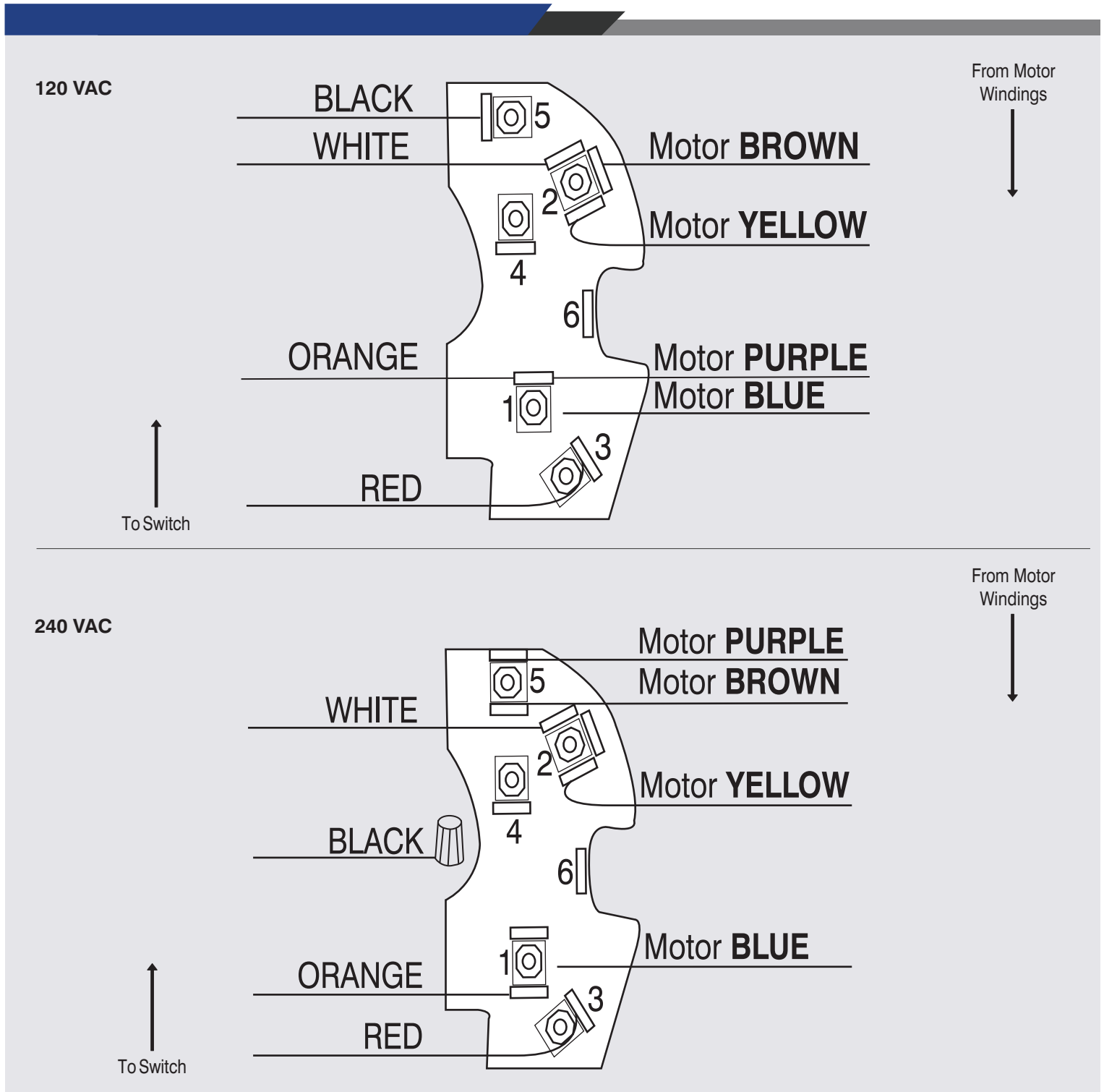

► To change motor direction, switch **Orange & White** Controller wires.

ATTENTION:

PROFESSIONAL LIFT INSTALLERS

The Elite Stainless Steel Motors were modeled after the Electra-Gear and Leeson Stainless Motors and will wire the exact same way. Use the Key for GEM Remotes use the column labeled standard colored wire, just to the right of the column used for Leeson and Regal Beloit at WWW.GEMREMOTES.COM The Elite Stainless Steel Motors are UL Controlled. If the motor doesn't work. Wire according to the information on this page and then reference the switch guide to be sure the wiring matches this guide.

THE FOLLOWING PROCEDURE IS FOR WIRING THE PRE-WIRED BH-USA DRUM SWITCH OR BH-USA WIRE HARNESS TO THE MOTOR. **Insure switch is wired to pg. 26**

step by step wiring videos available at bh-usa.com & youtube for this motor.

THIS DIAGRAM ALSO COVERS CERTAIN MODELS OF: A.O.Smith

120 VAC

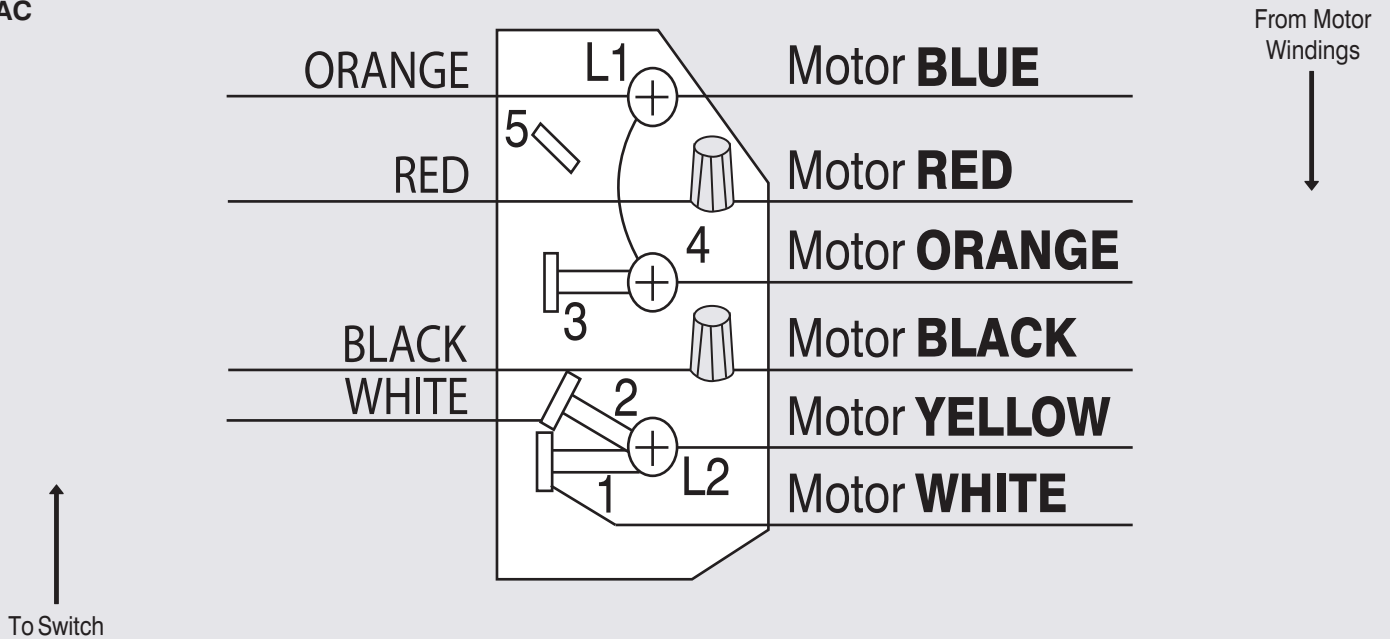

240 VAC

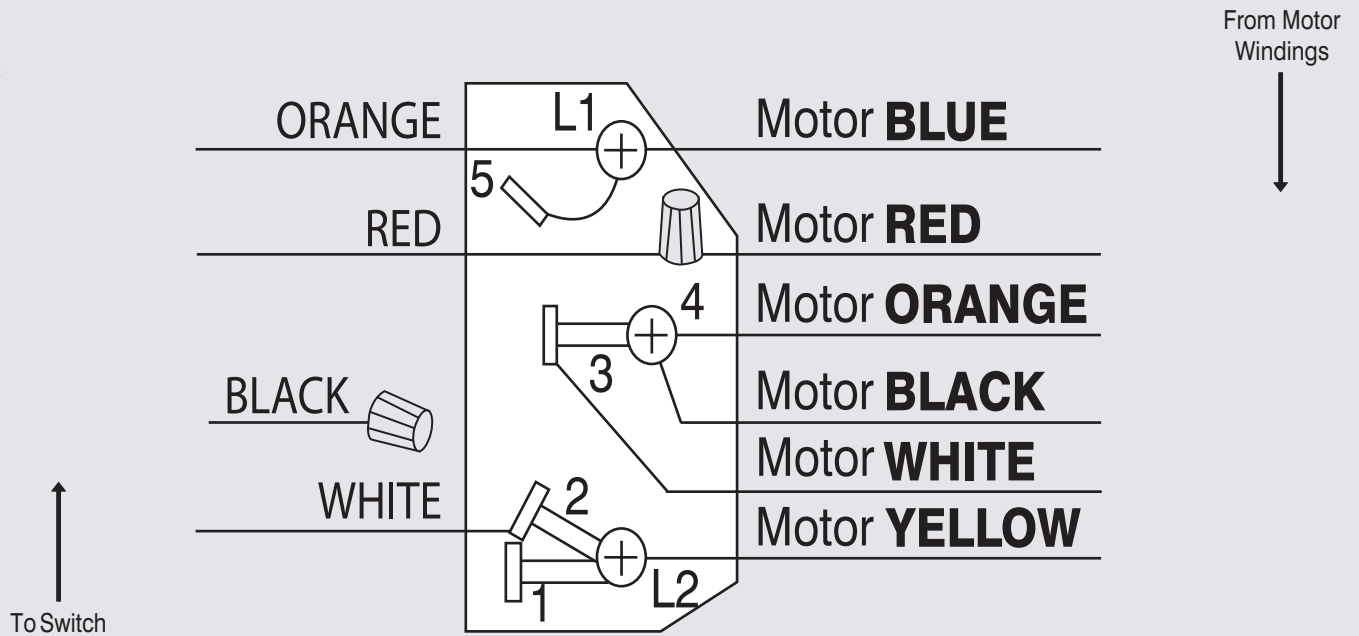

► To change motor direction, switch **Orange & White** Controller wires.

ATTENTION:
PROFESSIONAL LIFT INSTALLERS

The Elite Stainless Steel Motors were modeled after the Electra-Gear and Leeson Stainless Motors and will wire the exact same way. Use the Key for GEM Remotes use the column labeled standard colored wire, just to the right of the column used for Leeson and Regal Beloit at WWW.GEMREMOTES.COM The Elite Stainless Steel Motors are UL Controlled. If the motor doesn't work. Wire according to the information on this page and then reference the switch guide to be sure the wiring matches this guide.

THE FOLLOWING PROCEDURE IS FOR WIRING THE PRE-WIRED BH-USA DRUM SWITCH OR BH-USA WIRE HARNESS TO THE MOTOR. **Insure switch is wired to pg. 26**

step by step wiring videos available at bh-usa.com & youtube for this motor.

THIS DIAGRAM ALSO COVERS CERTAIN MODELS OF: (BALDOR "T" NUMBERED WIRES SEE NUMBERED WIRE DRAWING)

120 VAC

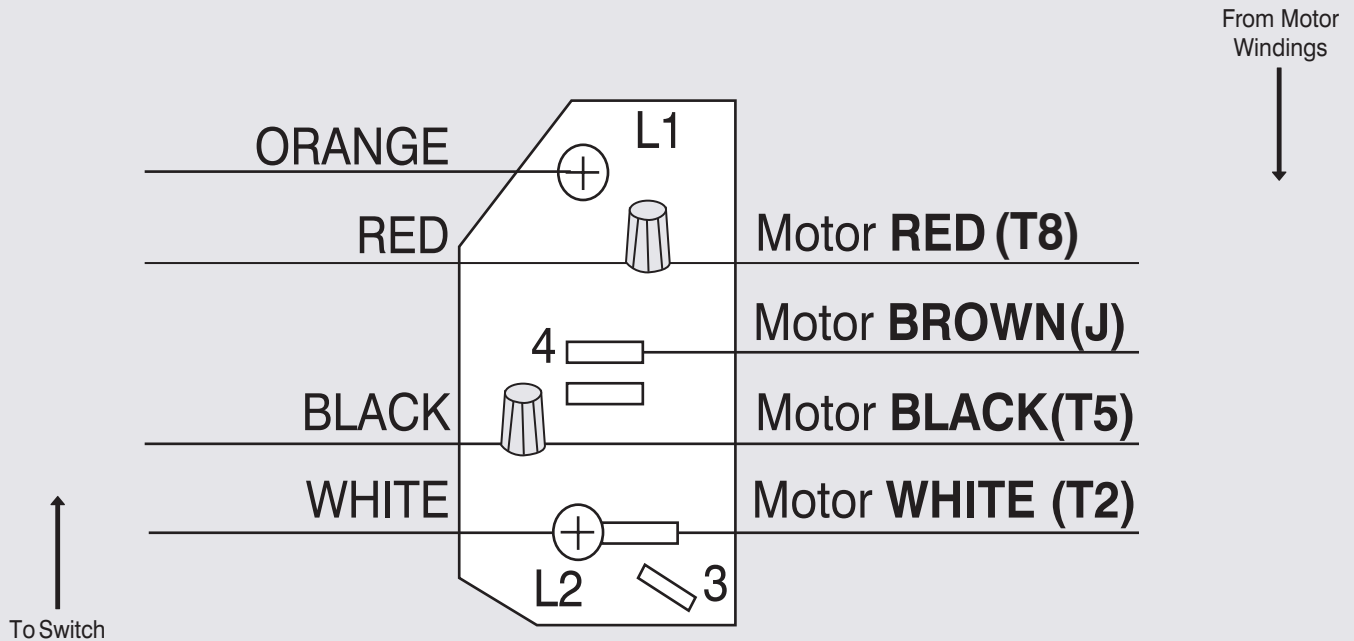

240 VAC

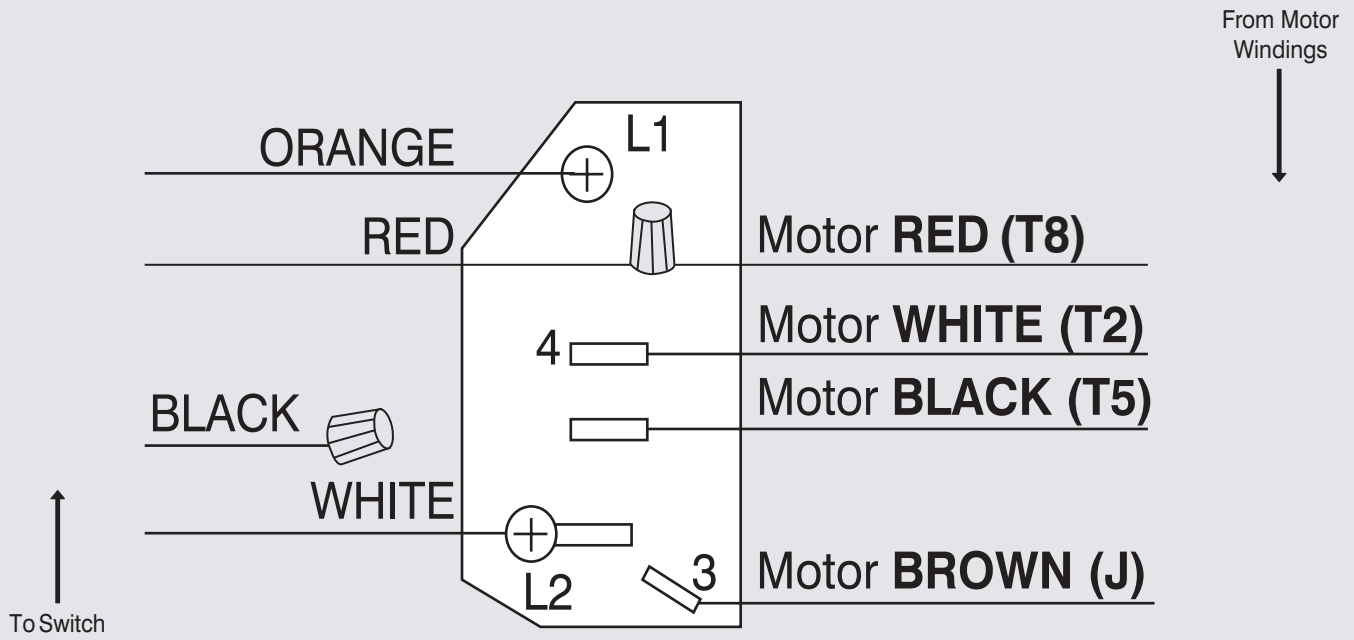

► To change motor direction, switch **Orange** & **White** Controller wires.

ATTENTION:
PROFESSIONAL LIFT INSTALLERS

The Elite Stainless Steel Motors were modeled after the Electra-Gear and Leeson Stainless Motors and will wire the exact same way. Use the Key for GEM Remotes use the column labeled standard colored wire, just to the right of the column used for Leeson and Regal Beloit at WWW.GEMREMOTES.COM The Elite Stainless Steel Motors are UL Controlled. If the motor doesn't work. Wire according to the information on this page and then reference the switch guide to be sure the wiring matches this guide.

THE FOLLOWING PROCEDURE IS FOR WIRING THE PRE-WIRED BH-USA DRUM SWITCH OR BH-USA WIRE HARNESS TO THE MOTOR. **Insure switch is wired to pg. 26**
 step by step wiring videos available at bh-usa.com & youtube for this motor.

THIS DIAGRAM ALSO COVERS CERTAIN MODELS OF: C412, C426, C523

120 VAC

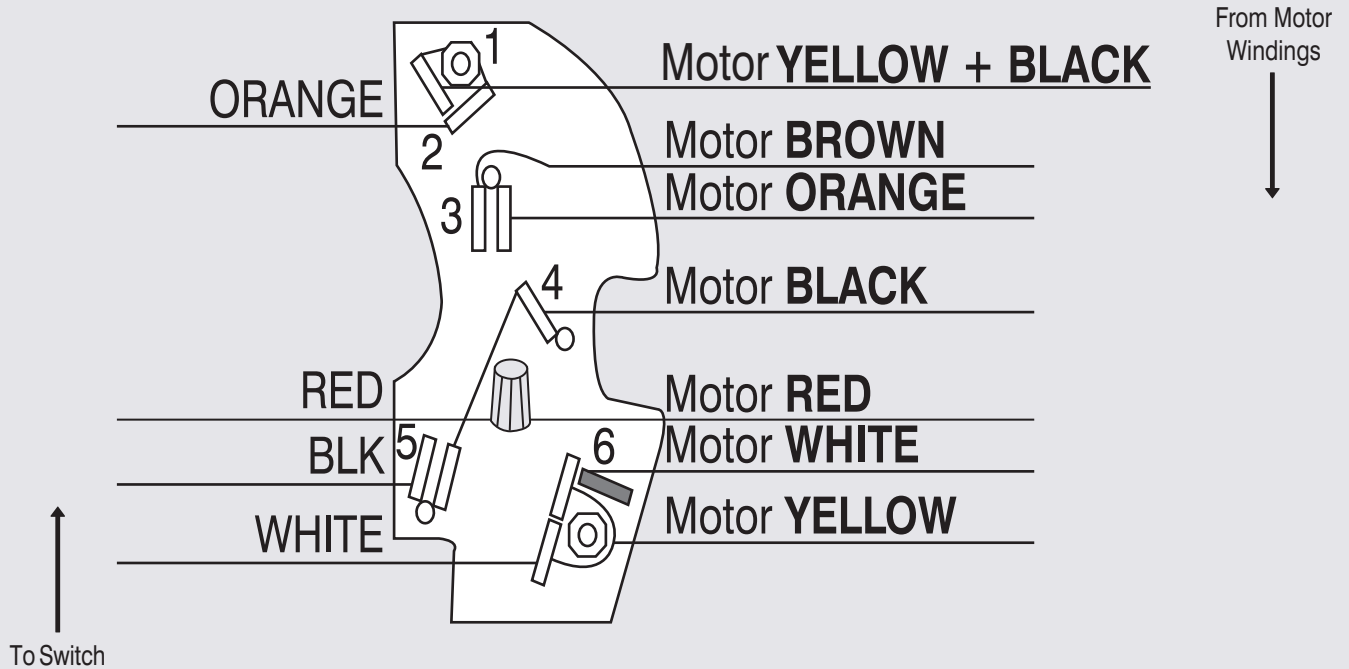

240 VAC

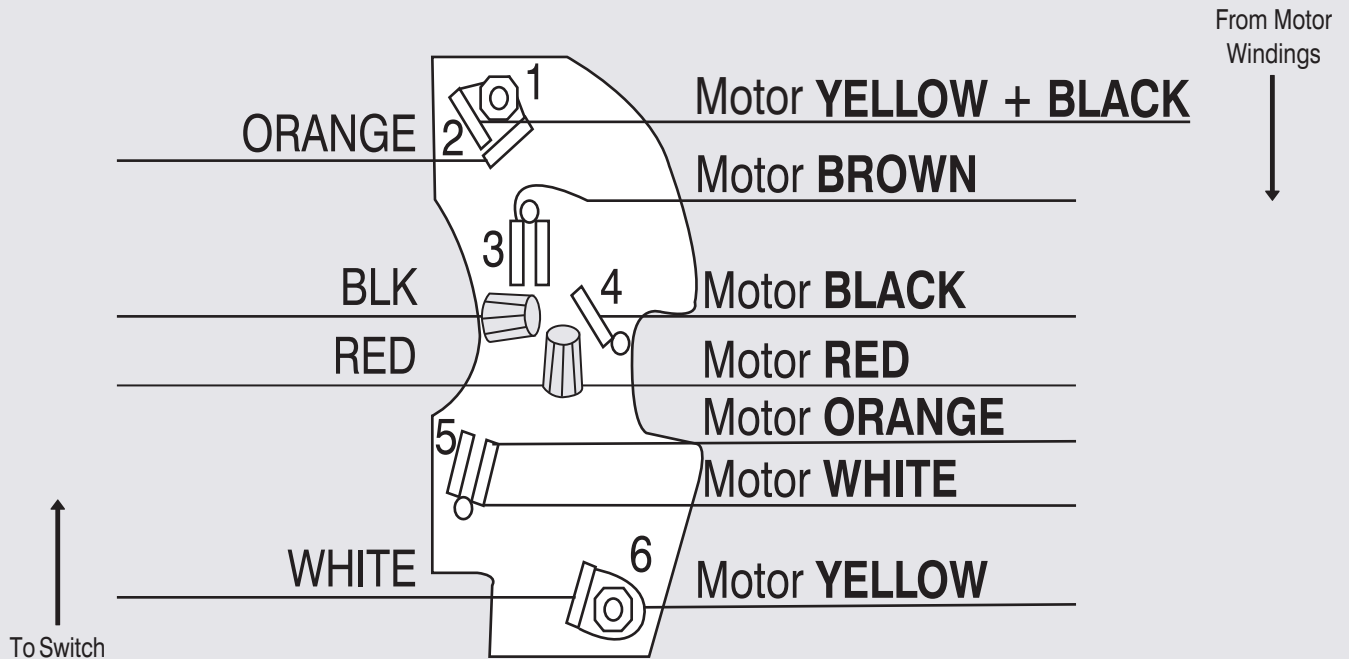

► To change motor direction, switch **Orange & White** Controller wires.

ATTENTION:
PROFESSIONAL LIFT INSTALLERS

The Elite Stainless Steel Motors were modeled after the Electra-Gear and Leeson Stainless Motors and will wire the exact same way. Use the Key for GEM Remotes use the column labeled standard colored wire, just to the right of the column used for Leeson and Regal Beloit at WWW.GEMREMOTES.COM The Elite Stainless Steel Motors are UL Controlled. If the motor doesn't work. Wire according to the information on this page and then reference the switch guide to be sure the wiring matches this guide.

THE FOLLOWING PROCEDURE IS FOR WIRING THE PRE-WIRED BH-USA DRUM SWITCH OR BH-USA WIRE HARNESS TO THE MOTOR. **Insure switch is wired to pg. 26**
 step by step wiring videos available at bh-usa.com & youtube for this motor.

THIS DIAGRAM ALSO COVERS CERTAIN MODELS OF: C926

120 VAC

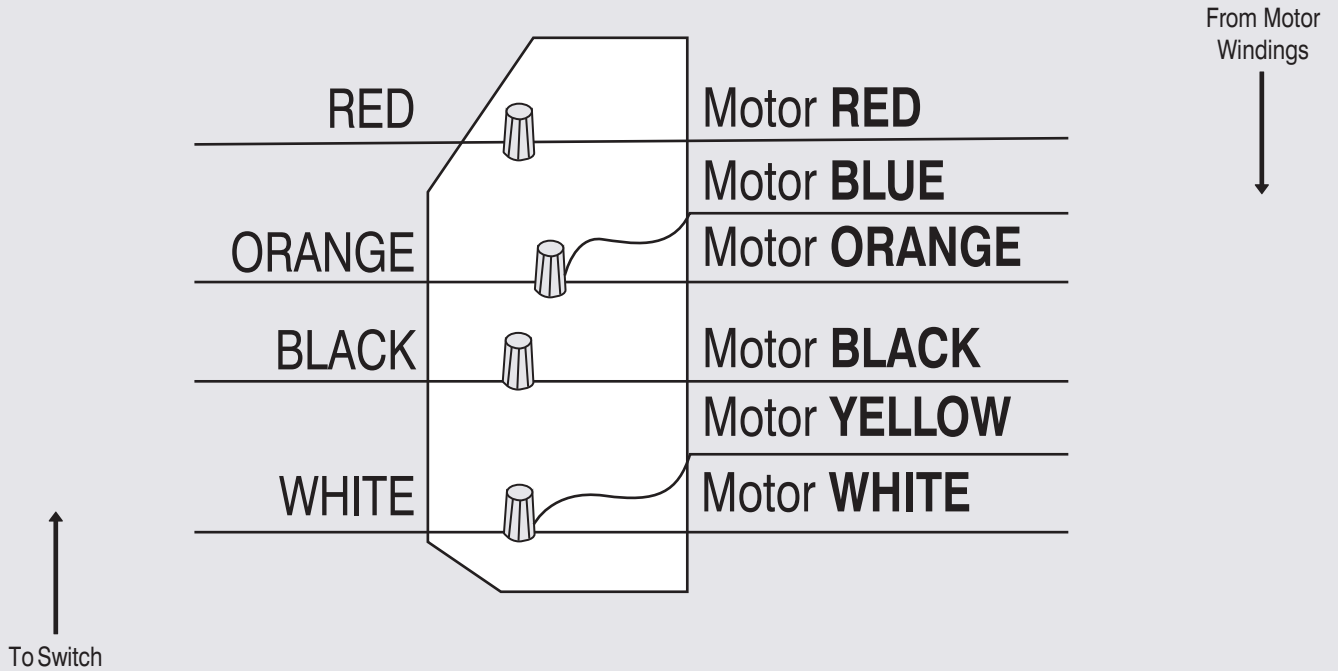

240 VAC

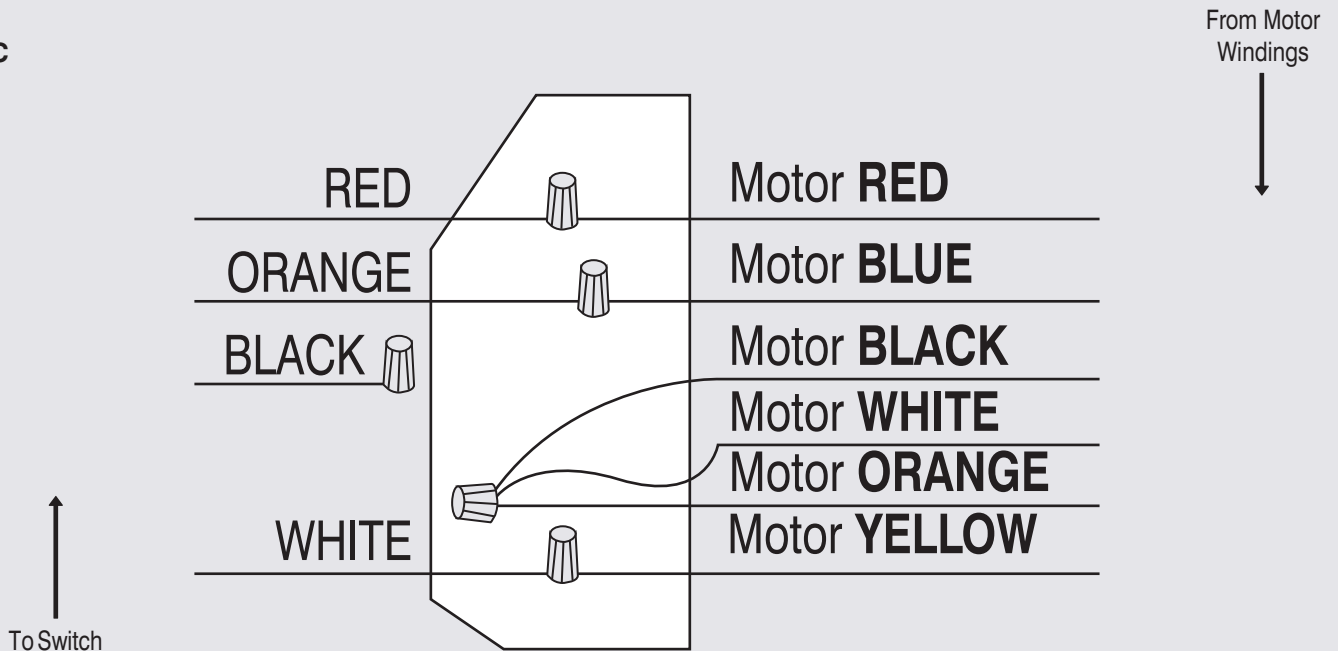

► To change motor direction, switch **Orange & White** Controller wires.

ATTENTION:
PROFESSIONAL LIFT INSTALLERS

The Elite Stainless Steel Motors were modeled after the Electra-Gear and Leeson Stainless Motors and will wire the exact same way. Use the Key for GEM Remotes use the column labeled standard colored wire, just to the right of the column used for Leeson and Regal Beloit at WWW.GEMREMOTES.COM The Elite Stainless Steel Motors are UL Controlled. If the motor doesn't work. Wire according to the information on this page and then reference the switch guide to be sure the wiring matches this guide.

THE FOLLOWING PROCEDURE IS FOR WIRING THE PRE-WIRED BH-USA DRUM SWITCH OR BH-USA WIRE HARNESS TO THE MOTOR. **Insure switch is wired to pg. 26**
 step by step wiring videos available at bh-usa.com & youtube for this motor.

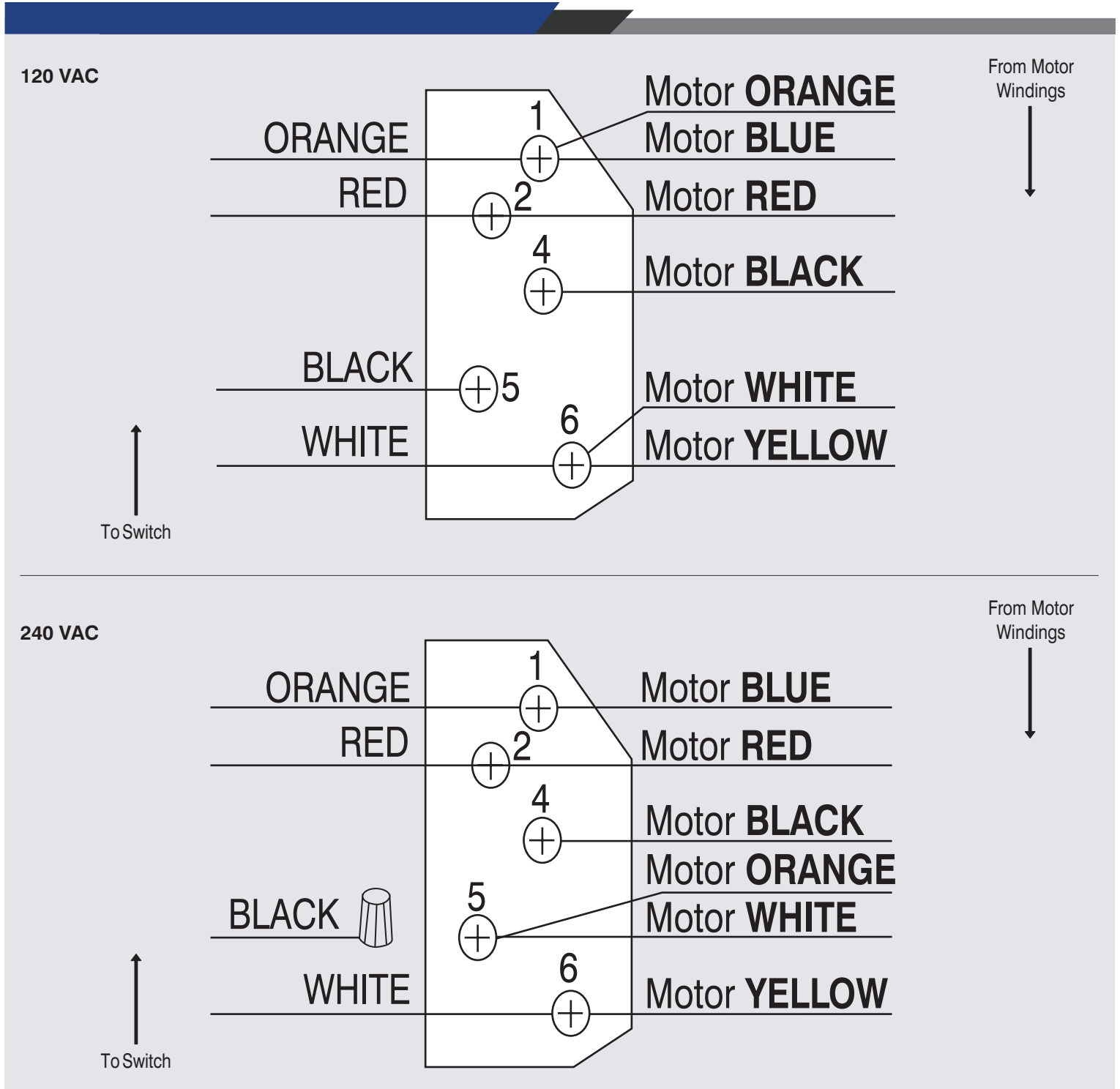

► To change motor direction, switch **Orange & White** Controller wires.

ATTENTION:

PROFESSIONAL LIFT INSTALLERS

The Elite Stainless Steel Motors were modeled after the Electra-Gear and Leeson Stainless Motors and will wire the exact same way. Use the Key for GEM Remotes use the column labeled standard colored wire, just to the right of the column used for Leeson and Regal Beloit at WWW.GEMREMOTES.COM The Elite Stainless Steel Motors are UL Controlled. If the motor doesn't work. Wire according to the information on this page and then reference the switch guide to be sure the wiring matches this guide.

THE FOLLOWING PROCEDURE IS FOR WIRING THE PRE-WIRED BH-USA DRUM SWITCH OR BH-USA WIRE HARNESS TO THE MOTOR. **Insure switch is wired to pg. 26**
 step by step wiring videos available at bh-usa.com & youtube for this motor.

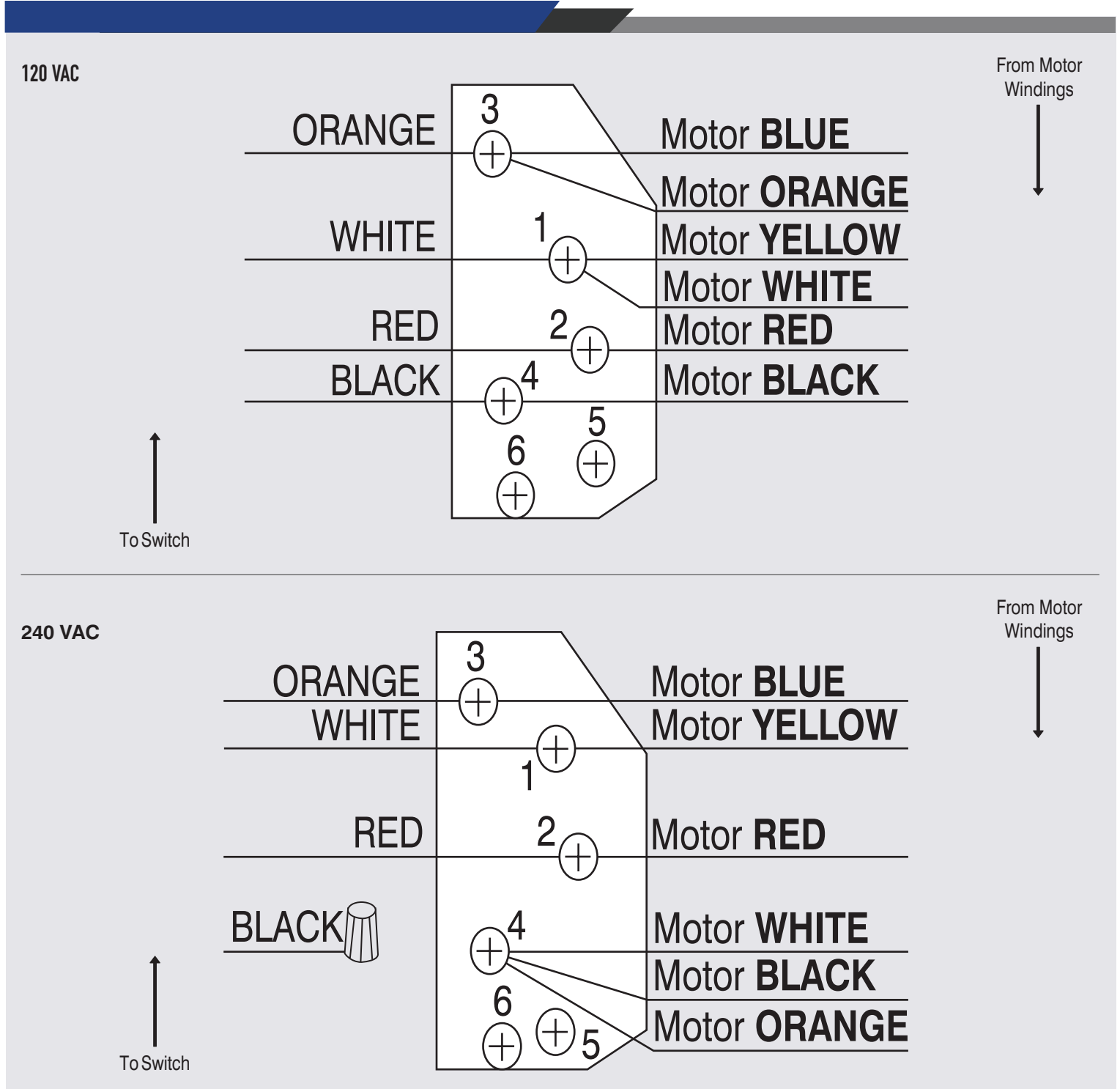

► To change motor direction, switch **Orange & White** Controller wires.

ATTENTION:

PROFESSIONAL LIFT INSTALLERS

The Elite Stainless Steel Motors were modeled after the Electra-Gear and Leeson Stainless Motors and will wire the exact same way. Use the Key for GEM Remotes use the column labeled standard colored wire, just to the right of the column used for Leeson and Regal Beloit at WWW.GEMREMOTES.COM The Elite Stainless Steel Motors are UL Controlled. If the motor doesn't work. Wire according to the information on this page and then reference the switch guide to be sure the wiring matches this guide.

Elite Motors Painted

110/220V

Horsepower	.75HP	1HP	1.5HP
Revolutions Per Min	1725	1725	1725
Voltage	115/230	115/230	115/230
AMPS needed at	11.0/5.5	15.6/7.8	19/8.5
115V	60	60	60
Herz			
Frame	56	56	56
Max Run Time	15M	15M	15M

Type	C	C	C
Service Factor	1	1/1.25	1
Phase	1	1	1
SFstart A	12.4/6.2		
AMB	40C	40C	40C
Code L	INS A	INS A	INS A
HSG	TENV	TENV	TENV

Elite Motors Stainless

110/220V

Horsepower	.75HP	1HP	1.5HP
Revolutions Per Min	1725	1725	1725
Voltage	115/230	115/230	115/230
AMPS needed at	11.0/5.5	15.6/7.8	19/8.5
115V	60	60	60
Herz			
Frame	56C	56C	56C
Max Run Time	15M	15M	15M

Type	C	C	C
Service Factor	1.25	1.15	1
Phase	1	1	1
SFstart A	17.5/8.75	12.4/6.2	19/8.75
AMB	40C	40C	40C
Code H	INS F	INS F	INS F
HSG	TENV	TENV	TENV

Leeson Red Farm Duty Motors

110/220V

Horsepower	1HP
Revolutions Per Min	1725
Voltage	115/230
AMPS needed at	14/7
115V	60
Herz	
Frame	56
Max Run Time	CONTINUOUS

Type	56F
Service Factor	1.15
Phase	Single
SFstart A	15/7.5
AMB	40C
Code K	INS B4
HSG	TEFC

Leeson & Electra Gear Motors

110/220V

Horsepower	.75HP	1HP
Revolutions Per Min	1725	1725
Voltage	115/230	115/230
AMPS needed at	19.4/9.7	13.8/6.9
115V	60	60
Herz		
Frame	56C	56C
Max Run Time	15M	15M

Type	C	C
Service Factor	1.25	1.25
Phase	1	
SFstart A	12.4/6.2	17.5/8.75
AMB	40C	40C
Code K	INS F	INS F
HSG	TENV	TENV

A.O.Smith Painted Motors

110/220V

Horsepower	.75HP	1HP
Revolutions Per Min	1725	1725
Voltage	115/230	115/230
AMPS needed at	12.2/6.1	12.2/6.1
115V	60	60
Herz		
Frame	56	56
Max Run Time	15M	15M

Type	C	C
Service Factor	1	1
Phase	1	1
SFstart A	13.4/6.7	13.4/6.7
AMB	40C	40C
Code K	INS B	INS B
HSG	TENV	TENV

Marathon Motors

110/220V

Horsepower	.75HP	1HP
Revolutions Per Min	1725	1725
Voltage	115/230	115/230
AMPS needed at	11.4/5.6	13.6/6.7
115V	60	60
Herz		
Frame	56	56
Max Run Time	15M	15M

Type	C	C
Service Factor	1.0	1.25
Phase	1	1
SFstart A	12.4/6.2	15.2/7.9
AMB	40C	40C
Code K	INS B	INS B
HSG	TENV	TENV

Step by Step wiring videos available at BH-USA.COM & YouTube for this motor.

THE FOLLOWING PROCEDURE IS FOR WIRING THE DRUM SWITCH TO THE BH-USA WIRE HARNESS AND MOTOR.

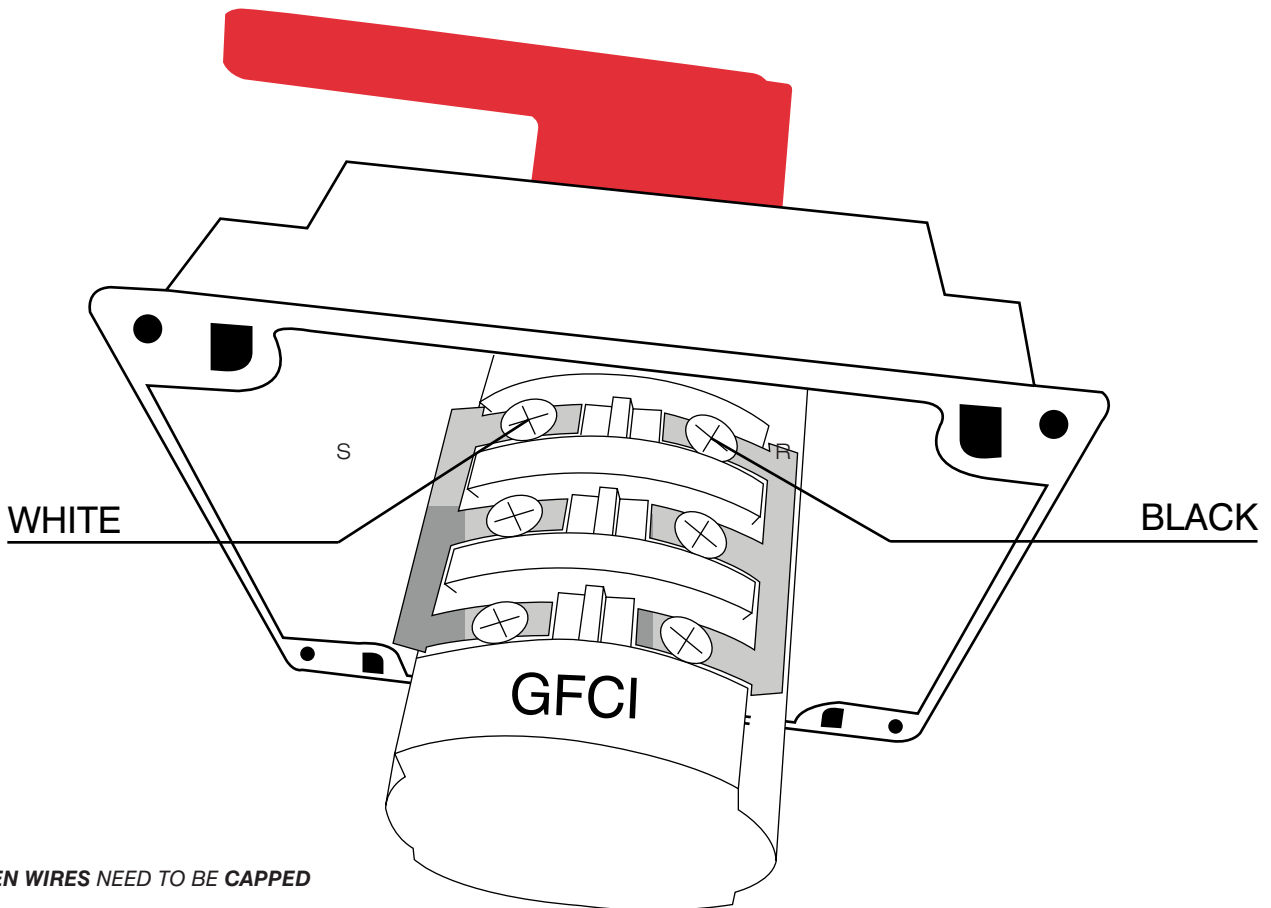
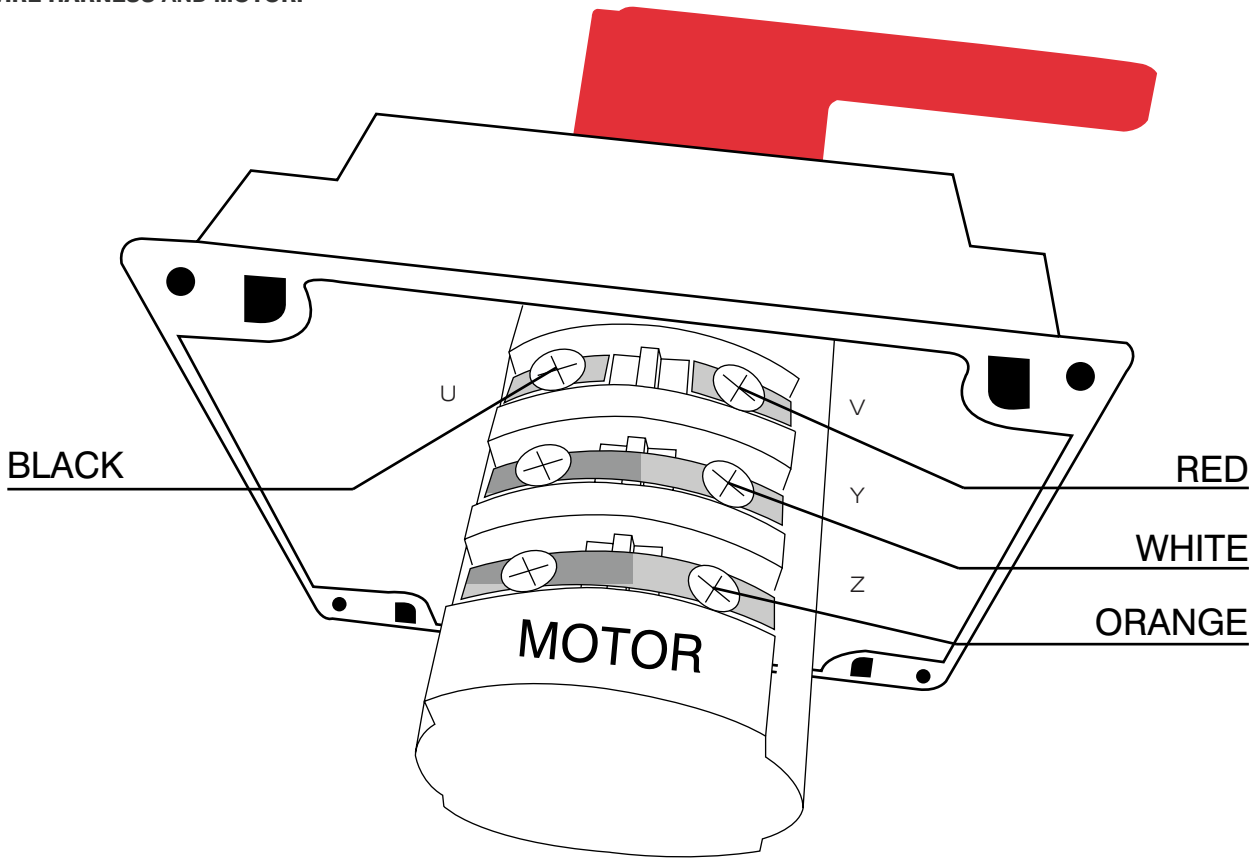

GREEN WIRES NEED TO BE CAPPED

Step by Step wiring videos available at BH-USA.COM & YouTube for this motor.

Step by Step wiring videos available at BH-USA.COM & YouTube for this motor.

Switches supplied by BH-USA have 4 holes drilled for proper mounting.

The figure illustrates how to mount the switch.

It should be mounted in a vertical position using all **4 bolt holes for the screws or bolts**.

When mounted **correctly**, the handle of the switch will point downward and the wires will protrude from the bottom of the switch.

It is **rare** for a switch to have a factory defect. Most switch problems are found in the wire connections to the switch terminals.

Moisture can also be a problem, as it causes corrosion between the terminal and the connection, thus disrupting it and causing the switch to not work.

Cleaning and tightening all connections can prevent this from happening. Small insects such as ants can also get into the contacts.

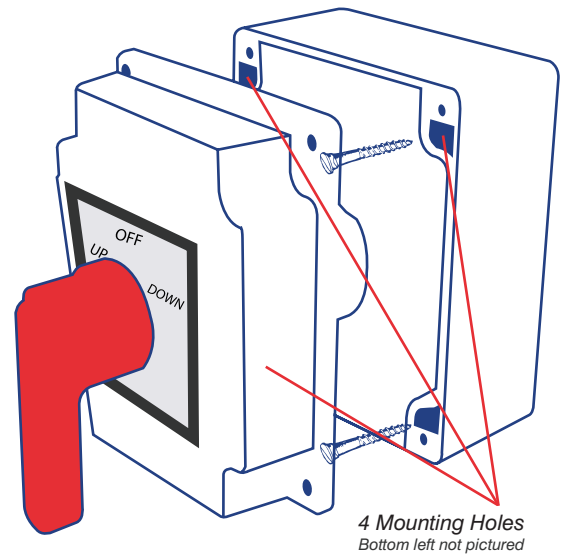

► BREMAS SWITCH EASY MOUNT BRACKETS (OPTIONAL)

Easily mount the switch to any surface without having to remove the front cover of the switch. Fits any red handle Bremas brand boat lift switch. Sold in pairs. Stainless steel fasteners to mount to the back of the switch included. Fasteners to mount the switch to any surface not included.

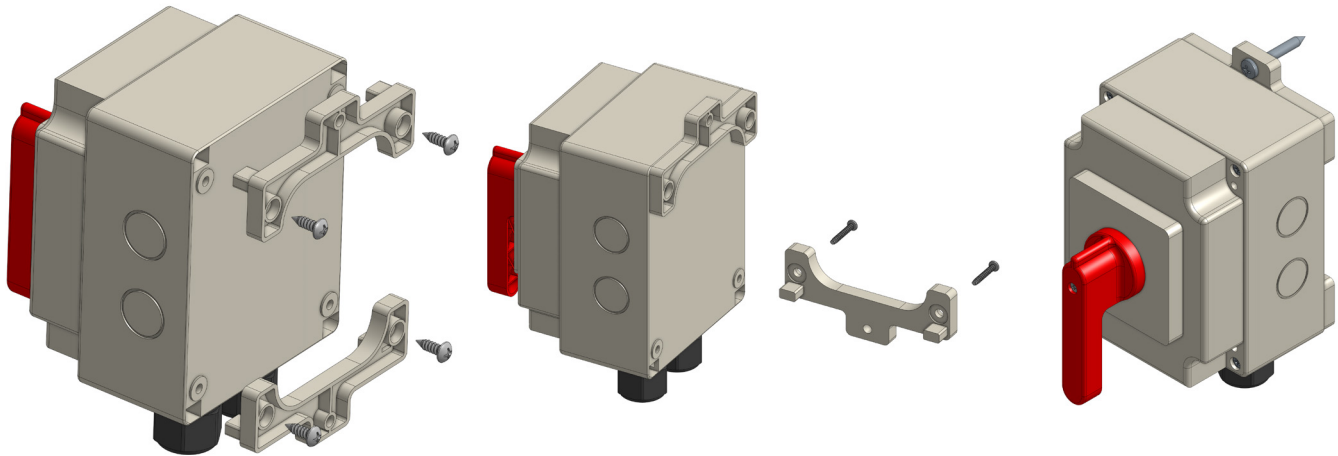

► IMPROPER INSTALLATION OF SWITCHES

- ✘ Never attempt to “hang” a switch from the boat hoist.
- ✘ Always permanently mount the switch to a structure.
- ✘ Switches should be mounted in a location requiring occupant to *exit the boat in order to reach it*.
- ✘ BH-USA’s line of flat plate hoists are not designed to lift people. **DO NOT** mount or hang the switch in any way that makes it accessible from within the boat.
- ✘ Hanging or mounting switches upside down will allow moisture and water to enter the switch and cause the switch to **malfunction**.

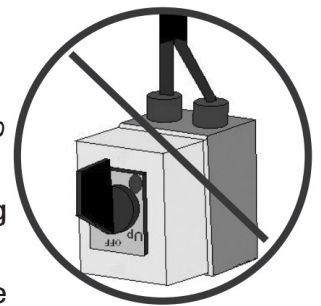

► Reversing the Motor

If your motor is running in the wrong direction you need to switch the orange and white wires

CAUTION DON'T VOID THE SWITCH WARRANTY

If you are not a licensed electrician, do not attempt to wire or rewire any electrical component. BH-USA will only be able to help with wiring the switches referenced in this guide. If you do not have one of these switches, BH-USA WILL NOT be able to help you. BH-USA Drum switches that have any sign of water damage or water inside the switch will not be covered under the manufacturer’s defect warranty. Switch warranties do not cover small insects or corroded terminals.

If you are not a licensed electrician, do not attempt to wire or rewire any electrical component. BH-USA will only be able to help with wiring switches sold by BH-USA.

STOP AND READ!

Do not attempt to screw the switch handle into the shaft without following these steps. You will damage the switch handle.

You **MUST REMOVE** the screw completely from the handle before installing. The shaft of the switch is **NOT** threaded so the handle is secured to the shaft by means of a plastic expansion tab inside the handle.

Step 1

Remove screw from handle before inserting on switch.

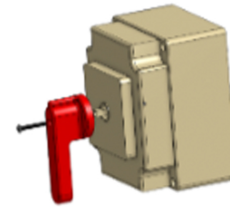

Step 2

Handle should be flush to face before inserting screw on shaft.

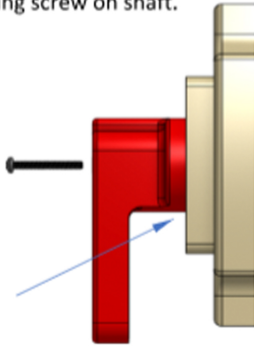

Step 3

If the handle will not fit flush, slightly bend expansion tabs to fit in hole of shaft before re-inserting.

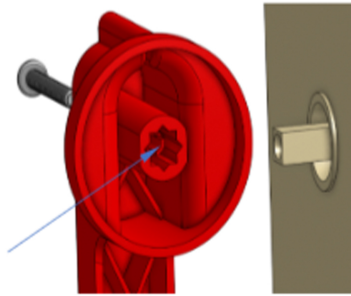

Step 4

Reinstall the handle. **DO NOT OVERTIGHTEN SCREW!**

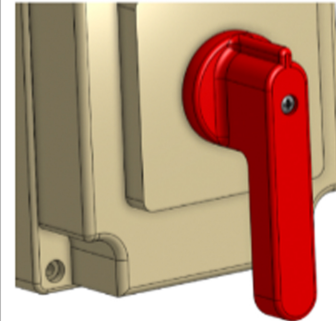

Using the Switch

Maintained

Momentary



OFF



UP



DOWN

Step by Step wiring videos available at BH-USA.COM & YouTube for this motor.



Other switches are included in this guide as a courtesy. The switch wiring directions on this page will only work if your existing motor is wired in accordance with the current BH-USA equipment guide. If you follow this guide and the motor only turns one direction you will have to re-wire your motor. BH-USA only offers directions and support for electric motors supplied and sold by BH-USA, which include Elite, Leeson, Marathon, and ElectraGear, **we will not be able to help with any other brand motor.** BH-USA does not stock or sell the **AMS, Bremas Black Handle, ACI or Furnas/Hubbell Switches.**



MOTOR WIRE TO SWITCH, 120V OR 240V
 Black: to Switch U or #T-1
 Red: to Switch V or #T-2
 White: to Switch Y or #8
 Orange: to Switch Z or #12
 Green: to GFCI (power) Green

FROM GFCI TO SWITCH, 120V OR 240V
 GFCI Blackto Switch R # L1
 GFCI Whiteto Switch S # L2
 Greento Control Green



MOTOR WIRE TO SWITCH, 120V OR 240V
 Black: to Switch #2
 Red: to Switch # 4
 White: to Switch # 8
 Orange: to Switch # 12
 Green: to GFCI (power) Green

FROM GFCI TO SWITCH, 120V OR 240V
 GFCI Blackto Switch # 1
 GFCI Whiteto Switch # 3
 Greento Control Green



MOTOR WIRE TO SWITCH, 120V OR 240V
 Black: to Switch # 2 (T-1)
 Red: to Switch #4 (T-2)
 White: to Switch # 8
 Orange: to Switch # 12
 Green: to GFCI (power) Green

FROM GFCI TO SWITCH, 120V OR 240V
 GFCI Blackto Switch # 1 L1
 GFCI Whiteto Switch #3 L2
 Greento Control Green



MOTOR WIRE TO SWITCH, 120V OR 240V
 Black: to Switch T-1
 Red: to Switch T-2
 White: to Switch 8
 Orange: to Switch 9
 Green: to GFCI Green

FROM GFCI TO SWITCH, 120V OR 240V
 Blackto Switch L1
 Whiteto Switch L2
 Greento Control Green



MOTOR WIRE TO SWITCH, 120V OR 240V
 Black: to Switch T-1
 Red: to Switch T-2
 White: to Switch 8
 Orange: to Switch 9
 Green: to GFCI Green

FROM GFCI TO SWITCH, 120V OR 240V
 Blackto Switch L1
 Whiteto Switch L2
 Greento Control Green



MOTOR WIRE TO SWITCH, 120V OR 240V
 White: to Switch # 1
 Red: to Switch # 2
 Orange: to Switch # 3
 Black: to Switch # 4
 Green: to GFCI (power) Green

FROM GFCI TO SWITCH, 120V OR 240V
 GFCI Blackto Switch # L1
 GFCI Whiteto Switch # L2
 Greento Control Green



WIRING FOR GEM REMOTES

CAN BE FOUND AT THEIR WEBSITE:

WWW.GEMREMOTES.COM

SCAN THE CODE WITH YOUR SMART DEVICE TO GO DIRECTLY TO GEM WEBSITE.

Step by Step wiring videos available at BH-USA.COM & YouTube for this motor.

▶ TROUBLE SHOOTING

- ✓ Check that the motor is **plugged in**.
- ✓ Check that the power is **on** and breakers are **reset**.
- ✓ Check that the **GFCI is reset**.
- ✓ Verify power at the outlet with a **portable light** or **voltage tester**.
- ✓ Does the motor turn in *one direction but not the other with nothing on it?* If so the problem is most likely with the **drum switch**.
- ✓ Check the switch connections for **corrosion or poor connection**.
- ✓ Check the wiring connections at the motor for the wires coming from the switch.*

Warning! *Avoid Burn-up... All motors are wired 220/230 from the factory. If you order "motor only" with no wiring harness or switch, and plan to use your motor on 110/115 service it must be rewired.*

▶ MOTOR WONT START TURNING, BUT IF STARTED MANUALLY, IT WILL RUN.

In all probability, the capacitor has **failed**. Replacing the capacitor should allow the motor to start properly.

Warning! *Avoid serious injury by NEVER using your hands to manually start a motor.*

▶ Motor cant be turned at all by hand when the power is off.

- Remove the motor from the lift.
- If the motor can **NOT** be turned by hand while it is not on the lift, the motor is frozen and must be replaced.
- If the motor can be turned by hand while it is not on the lift, check the gearbox for problems.
- Check to see if the gearbox is stuck.
- Troubleshoot the motor again while it is **NOT** on the lift.

* See BH-USA Motor Specifications and Wiring Diagrams in this guide.

▶ MOTOR WONT START TURNING, BUT IF STARTED MANUALLY, IT WILL RUN.

In all probability, the capacitor has **failed**. Replacing the capacitor should allow the motor to start properly.

▶ **MOTOR CAN BE MANUALLY TURNED BY HAND, BUT WHEN POWERED ON, DOESN'T TURN.**

- ✓ Check that the motor is **wired correctly** for your switch.
- ✓ Motor may not be receiving proper power. **NEVER ASSUME** a motor has proper power unless it has been checked at the motor. Sometimes bad connections or corrosion cause insufficient power
- ✓ If the motor is wired properly and the voltage has been verified at the motor connection the motor may be **burned out**.

▶ **MOTOR STARTS & RUNS, BUT WON'T PICK UP THE LOAD.**

- ✓ Check for a **low-voltage problem**.
- ✓ **NEVER** use an extension cord. It will cause low voltage and poses a **fire danger**.
- ✓ **NEVER** use a generator.
- ✓ Check the voltage at the plug when the motor is **not running**.
- ✓ Check the voltage at the motor when it is trying to **pick up the load**.
- ✓ If there is more than a **4%** difference between the voltage measurement at the plug and the measurement at the motor, there is a low-voltage condition.
- ✓ Check that the proper size wiring has been used for the length of run from the main panel (**not a sub-panel**) at the house all the way to the lift.
- ✓ Check the switch for corrosion, bad connection or power loss.
- ✓ Check the voltage at the input side of the switch and the output side of the switch. If there is a difference, the switch either has a bad connection or is defective.
- ✓ If the voltage is fine at the output side of the switch, but drops at the motor, check the motor wiring connections.
- ✓ Check for an overloading condition.
- ✓ If the voltage doesn't drop more than **4%**, but the amperage rises above the full-load amperage rating and stays there, then there is an overloading condition with the lift.
- ✓ Check the full-loaded weight of the boat on the lift.
- ✓ Check the lift for problems with something rubbing or causing additional resistance that may cause additional strain on the motor.
- ✓ Electric, flat-plate hoist motors reverse using a drum switch and operate at 110/115 volts or **220/230 volts** at **1725 RPM**. Electric boat hoists are not water tight. All BH-USA's boat lift motors have a start capacitor and are totally enclosed non-venting (**TENV**), meaning all thermal protection has been removed, giving these motors a maximum **15 minute run time**.
- ✓ All motors ordered without wiring harnesses/switches from BH-USA are wired from the factory for **220V**. "Motor only" **ORDERS** include no electrical connectors such as spades and wire nuts.

PLEASE READ LEGAL NOTICE

BH-USA assumes no responsibility or liability from improper wiring or misuse of equipment, and will only supply information for BH-USA equipment. Only a licensed electrician should wire or re-wire any electrical component.

BH-USA attempts to provide accurate material and information which is intended to be for general reference and informational purposes only. Although BH-USA strives to keep all printed and published materials up-to-date, they could contain inaccurate, incomplete, or out-of-date material or information. BH-USA assumes no responsibility for errors or omissions in the content of said materials, and makes no commitment to update such material or information. Your sole and exclusive remedy for issues relating to the use of, or the material or information published by BH-USA shall be to discontinue accessing the BH-USA Website or using the material or information contained herein.

▶ HOW DO I WIRE MY MOTOR TO THE GEM REMOTE?

Follow the instructions in the GEM Wiring Instructions. Updated June 2015 http://www.gemremotes.com/wiring_diagrams.html

▶ I INSTALLED A NEW MOTOR, BUT IT IS HAVING THE SAME PROBLEM AS THE MOTOR I REPLACED.

The issue is likely not with the motor. Switches are more likely to go bad than the motor and should always be replaced when you replace a motor. Try installing a new switch and if that doesn't work look into either not enough power to the motor or too much of a load on the motor.

▶ THE MOTOR LOWERS THE LIFT JUST FINE, BUT STOPS WHILE LIFTING THE BOAT.

Either the load is too much or there is not enough power to the motor. Check and make sure that all friction points on the lift and hoist are well greased and not in any kind of bind or that the boat isn't too heavy. Check the voltage both when the motor is off and on and see how much the voltage drops. If it drops below 110 or 220 volts then there is not enough power going to the motor to make it run properly. Do not use extension cords or generators to operate the lift.

▶ THE MOTOR SURGES WHEN LIFTING THE BOAT.

Either the load is too much or there is not enough power to the motor. Check and make sure that all friction points on the lift and hoist are well greased and not in any kind of bind or that the boat isn't too heavy. Check the voltage both when the motor is off and on and see how much the voltage drops. If it drops below 110 or 220 volts then there is not enough power going to the motor to make it run properly. **Do not use extension cords or generators to operate the lift.**

▶ HOW DO I WIRE A MOTOR THAT IS NOT A BH-USA LISTED MOTOR TO A SWITCH YOU SELL?

We provide support **ONLY** for motors we sell. We have tested all the motors we sell with all the switches we sell to ensure they function properly. We are not able to test motors we don't sell and therefore can't offer any support.

▶ HOW DO I WIRE A MOTOR TO A SWITCH THAT YOU DON'T SELL?

We provide support **ONLY** for switches we sell. Each company makes switches differently. We can only provide guidance for those switches we sell since the switch has different contacts and pathways for each model of switch and we have no way of knowing how switches other than those we sell are configured.

▶ WHICH WIRE IS THE UP AND WHICH WIRE ARE THE DOWN WIRES?

There is no up or down wire in the motors. The motor runs either clockwise or counter-clockwise depending on whether the run and start fields in the motor are in or out of phase with each other. The red and black wires or **T5 and T8**, depending on the motor, are the start field and the rest are tied to the run fields.

LIMITED WARRANTY**Electric Motor**

BH-USA hereby warrants to the original retail purchaser of an electric motor supplied by BH-USA that the motor is free from defective materials and workmanship for a period of one year from the date of purchase, unless otherwise stated, when purchased directly from BHUSA or a dealer authorized by BH-USA to sell such products. This limited warranty is valid only when this product is used under normal conditions of recommended use as outlined in the BH-USA Equipment Guide. If BH-USA determines the motor failed due to a manufacturer's defect, BH-USA will repair or replace at our discretion, product manufactured, assembled, wired, or supplied by BH-USA without charge during the first year.

Any products, component parts, equipment, and accessories not manufactured or supplied by BH-USA are not covered by the provisions of this warranty. This includes existing wire harnesses, if the motor is purchased without wire harness supplied by BH-USA. If this is the case, this warranty is only valid if a licensed electrician wired the existing wire harness to a motor supplied by BH-USA. Other than as set forth above, BH-USA makes no other express or limited warranties with respect to any product or component part or manufactured part sold by BH-USA. Any implied warranties of merchantability or fitness for a particular purpose are limited to one year from the date of sale to the original end user of the product.

THE FOLLOWING ITEMS WILL VOID WARRANTY:

1. ANY PRODUCT OR COMPONENT PART WHICH HAS BEEN SUBJECT TO ABUSE, NEGLIGENCE, ACCIDENT, OR IMPROPER USE;
2. ANY PRODUCT OR COMPONENT PART WHICH HAS BEEN ALTERED OR REPAIRED BY ANYONE NOT AUTHORIZED BY BH-USA TO MAKE SUCH ALTERATIONS OR REPAIRS DURING THE TERM OF THIS WARRANTY;
3. ANY PRODUCT OR COMPONENT PART WHICH HAS BEEN SUBJECTED TO UNNECESSARY STRESS;
4. ANY DEFECT, DAMAGE, OR INJURY RESULTING FROM THE CONSUMER OR ANY OTHER PERSON STANDING ON ANY BOAT, PLATFORM, OR OTHER SUCH ITEM WHICH IS ATTACHED TO ANY PRODUCT OR COMPONENT PART THEREOF;
5. ANY DEFECT, DAMAGE, OR INJURY ATTRIBUTED TO TRANSPORTATION OF ANY PRODUCT OR COMPONENT PART THEREOF;
6. DEFECTS IN MATERIALS OR WORKMANSHIP WHICH COULD HAVE BEEN DISCOVERED BY A REASONABLE EXAMINATION OF THE PRODUCT OR COMPONENT PARTS UNDER NORMAL USE AND SERVICE;
7. ANY INCIDENTAL OR CONSEQUENTIAL DAMAGES OR INJURIES.
8. ANY SIGNS OF WATER MOISTURE IN MOTOR
9. ANY SIGNS OF MOTOR OVERHEATED

LIFETIME WARRANTY**Gear Plate Assembly (GPA)**

BH-USA guarantees to the original purchaser a lifetime warranty for as long as they own the gear plate assembly (GPA). The GPA is free from defective materials and workmanship for the life of the GPA. BH-USA will replace any GPA found to have a manufacturer's defect. This lifetime warranty is valid only when this product is used under normal conditions of recommended use as outlined in this packet.

BH-USA will only replace merchandise or products manufactured or supplied by BH-USA. All BH-USA gear plates have a rating posted on the front of the gear plate assembly. Do not exceed the rating of the gear plate being used. Exceeding the rating will void the warranty.

BH-USA will not be responsible for any incidental or consequential damages or injuries. The guarantee does not cover ordinary wear and tear. As with any gear, component parts, especially moving parts, will show wear over time and may eventually need to be refurbished or replaced. This warranty is predicated on the hoist being inspected and serviced on an annual basis by a qualified technician.

A record of inspection is required with any warranty request. The BH-USA Lifetime Warranty is non-transferable and only applies to the original purchaser who has filled out and returned the warranty

THE FOLLOWING ITEMS WILL VOID WARRANTY:

1. EXCEEDING THE WEIGHT RATING POSTED ON THE FRONT OF THE GEAR PLATE ASSEMBLY;
2. SUBJECTING THE GPA TO ABUSE, NEGLIGENCE, ACCIDENT, OR IMPROPER USAGE;
3. ALTERATION OR REPAIR OF THE GPA BY ANYONE NOT AUTHORIZED BY BHUSA;
4. INSTALLING THE GPA INCORRECTLY OR USING THE HOIST IN A LIFT THAT IS CONSIDERED IMPROPERLY INSTALLED;
5. USING THE GPA AS A LOAD BEARING UNIT;
6. USING THE GPA FOR ANY PURPOSE OTHER THAN LIFTING A BOAT;
7. IGNORING DEFECTS IN MATERIALS OR WORKMANSHIP WHICH COULD HAVE BEEN DISCOVERED BY A REASONABLE EXAMINATION OF THE PRODUCT OR COMPONENT PART UNDER NORMAL USE AND SERVICE;
8. USING THE GPA FOR NON-RESIDENTIAL OR COMMERCIAL USE;
9. ANYTHING BH-USA DEEMS OUTSIDE THE INTENDED USE OF THIS PRODUCT.
10. ANY SIGN OF GEAR WEAR OR BROKEN TEETH ARE NOT COVERED

All defective parts must be returned to BH-USA with the required information to be considered for warranty replacement within 30 days of failure. Items must be shipped pre-paid and must have a returned merchandise authorization (RMA) number on outside of box (s).

Please contact BH-USA for warranty issues or to have an RMA number assigned to your return. This warranty is valid only if an annual inspection record is presented by a professional lift installer.

Information and inspection records should include the following:

- ▶ Date of Installation
- ▶ Type of lift
- ▶ Weight being lifted
- ▶ Detailed description of the problem
- ▶ Any service history

FIVE YEAR WARRANTY

Enclosed Drives

REVISED APRIL, 2019 ALL PREVIOUS REVISIONS ARE VOID

BH-USA guarantees to the original purchaser a two-year warranty on the BH-USA's A-Drive to be free of any and all manufacturing defects in material and workmanship. BH-USA will only cover damage to the A-Drive due to defects in workmanship or quality of the material.

Warranty is valid only when this product is used under normal conditions of recommended use. BH-USA will only replace merchandise or products manufactured or supplied by BH-USA.

BH-USA reserves the right, to either repair or replace the A-Drive or its components at our discretion. This warranty does not cover damage resulting from abuse, neglect, improper handling or incorrect installations. Warranty is predicated upon the A-Drive being inspected and serviced on an annual basis, by a qualified technician. A record of inspection is required with any warranty request. Do not exceed the posted rating of the gear plate being used. BH-USA will not be responsible for any incidental or consequential damages or injuries. This guarantee does not cover ordinary wear and tear. As with any gear component parts, particularly moving parts, will show wear over time and eventually will need to be replaced. If such wear and tear occurs, BH-USA can sell you a new worm gear reducer. Any person using equipment manufactured by BH-USA will be subject to all BH-USA terms and conditions. Warranty does not include the gears or machined parts on the hoist and is intended for the overall assembly only.

THE FOLLOWING ITEMS WILL VOID WARRANTY:

1. EXCEEDING THE WEIGHT RATING POSTED ON THE FRONT OF THE GEAR PLATE ASSEMBLY;
2. SUBJECTING THE A-DRIVE TO ABUSE, NEGLIGENCE, ACCIDENT, OR IMPROPER USAGE;
3. ALTERATION OR REPAIR OF THE A-DRIVE BY ANYONE NOT AUTHORIZED BY BH-USA;
4. INSTALLING THE A-DRIVE INCORRECTLY OR USING THE HOIST IN A LIFT THAT IS CONSIDERED IMPROPERLY INSTALLED;
5. USING THE A-DRIVE AS A LOAD BEARING UNIT;
6. USING THE A-DRIVE FOR ANY PURPOSE OTHER THAN LIFTING A BOAT;
7. IGNORING DEFECTS IN MATERIALS OR WORKMANSHIP WHICH COULD HAVE BEEN DISCOVERED BY A REASONABLE EXAMINATION OF THE PRODUCT OR COMPONENT PART UNDER NORMAL USE AND SERVICE;
8. USING THE A-DRIVE FOR NON-RESIDENTIAL OR COMMERCIAL USE;
9. ANYTHING BH-USA DEEMS OUTSIDE THE INTENDED USE OF THIS PRODUCT.

30-DAY WARRANTY

Switches and GFCIs

BH-USA guarantees to the original purchaser a 30 day warranty on the BH-USA's switches and GFCIs to be free of any and all manufacturing defects in material and workmanship. BH-USA will only cover damage to switches and GFCIs due to defects in workmanship or quality of the material. Warranty is valid only when this product is used under normal conditions of recommended use.

Switches and GFCI will not be warranted if found to have dirt, debris, insects, corrosion or other signs of water penetration. Switches and GFCI will not be covered under warranty if found to have any signs of arcing or burning of the conductors.

BH-USA will only replace merchandise or products manufactured or supplied by BH-USA. BH-USA reserves the right, to either repair or replace the A-Drive or its components at our discretion. This warranty does not cover damage resulting from abuse, neglect, improper handling or incorrect installations.

Warranty is predicated upon the switches and electrical components being inspected and serviced on an annual basis, by a qualified technician. A record of inspection is required with any warranty request. BH-USA will not be responsible for any incidental or consequential damages or injuries.

Any person using equipment manufactured by BH-USA will be subject to all BH-USA terms and conditions.

THE FOLLOWING ITEMS WILL VOID WARRANTY:

1. ANY TYPE OF INCORRECT INSTALLATION;
2. EVIDENCE OF WATER PENETRATION;
3. EVIDENCE OF DIRT, DEBRIS OR INSECTS WITHIN THE SWITCH OR GFCI;
4. EVIDENCE OR CORROSION ON TERMINALS, OR ANY OTHER TYPE OF MOISTURE RELATED DEFECT;
5. EVIDENCE OF ARCING OR IMPROPER VOLTAGE;
6. BURNT CONDUCTORS.

All defective parts must be returned to BH-USA with the required information to be considered for warranty replacement within 30 days of failure. Items must be shipped pre-paid and must have a returned merchandise authorization (RMA) number on outside of box (s).

Please contact BH-USA for warranty issues or to have an RMA number assigned to your return. This warranty is valid only if an annual inspection record is presented by a professional lift installer.

Information and inspection records should include the following:

- ▶ Date of Installation
- ▶ Type of lift
- ▶ Weight being lifted
- ▶ Detailed description of the problem
- ▶ Any service history

