

PYLE

PyleUSA.com



USER'S MANUAL

UHF WIRELESS MICROPHONE SYSTEM

PDWM1902 • PDWM1904 • PDWM3375 • PDWM3378 • PDWM3400

SYSTEM TYPE

- The Vocal Artist-UHF is a hand-held system designed for singers who desire the high quality microphones and the freedom of wireless performance.
- The Presenter-UHF is a body-pack system designed for public speakers who prefer an inconspicuous, hands-free lavalier microphone.
- The Headset-UHF is a body-pack system designed for users in physically active applications, who desire the freedom of hand-free microphone.

CHANNEL RECEIVER

SINGLE CHANNEL RECEIVER

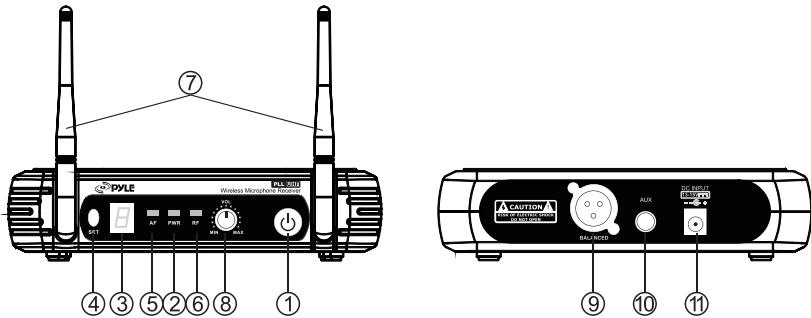

1. Power Button: Power ON/OFF the receiver.
2. Power Indicator: Indicate the power ON/OFF.
3. Channel Display: Indicates the frequency data of the selected channel group.
4. SET Function Button: Sets channel data.
5. "AF" Audio Level Indicator: Indicate the wireless system audio signal level.
6. "RF" signal indicator: it glows when the Receiver receive RF signal from Transmitter.
7. Antenna.
8. Volume Knob: Adjust the volume output of receiver.
9. XLR Balanced Output Jack: Connect the audio cable from this jack to the input port of amplifier, mixer.
10. 1/4" Audio Output Jack: Connect the audio cable from this jack to the input port of amplifier, mixer.
11. Power Jack: Connect the AC/DC adapter to receiver.

DUAL CHANNEL RECEIVER

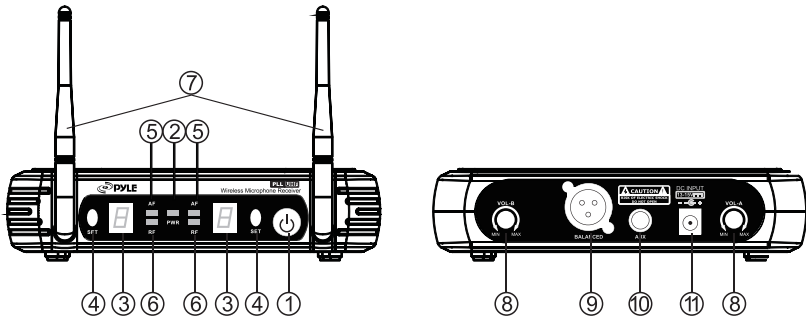

1. Power Button: Power ON/OFF the receiver.
2. Power Indicator: Indicate the power ON/OFF.
3. Channel Display: Indicates the frequency data of the selected channel group.
4. SET Function Button: Sets channel data.
5. "AF" Audio Level Indicator: Indicate the wireless system audio signal level.
6. "RF" signal indicator: it glows when the Receiver receive RF signal from Transmitter.
7. Antenna.
8. Volume Knob: Adjust the volume output of receiver.
9. XLR Balanced Output Jack: Connect the audio cable from this jack to the input port of amplifier, mixer.
10. 1/4" Audio Output Jack: Connect the audio cable from this jack to the input port of amplifier, mixer.
11. Power Jack: Connect the AC/DC adapter to receiver.

MICROPHONE FUNCTIONS

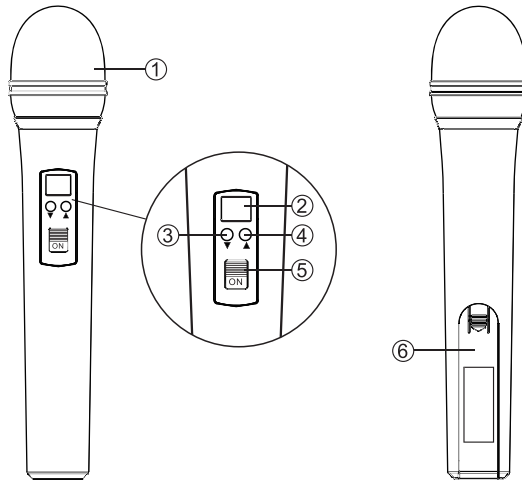

1. Grille: Protects the cartridge and help reducing the breath sounds and wind noise.
2. Channel Display: Indicates the frequency data of the selected channel group.
3. Down Function Button: Sets channel data.
4. Up Function Button: Sets channel data.
5. Power and Audio Mute Switch.
6. Battery Cover: Open it to install the battery.

TRANSMITTER FUNCTIONS

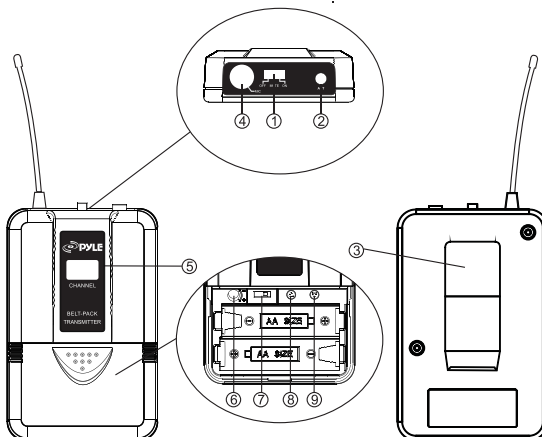

PYLE

1. Power and Audio Mute Switch.
2. Antenna: Transmit the RF signal of transmitter.
3. Belt Clip: Attach the transmitter to the belt.
4. Audio Input Jack: it is suitable for lavalier system/headset system.
5. Channel Display: Indicates the frequency data of the selected channel group.
6. Gain Adjusting Volume: Adjust the transmitter audio input gain.
7. State Setting Switch: Set the using state of lavalier system(L)/headset system(H).
8. Up Function Button: Sets channel data.
9. Down Function Button: Sets channel data.

RECEIVER CONNECTIONS

1. Receiver Power Connection: Connect the AC adapter into the DC power connector on the back of the receiver. Plug the AC adapter into a AC 120V/220V 50Hz outlet.



2. Antenna: Keep the position of antenna at a 45 angle from vertical, (Shown as below)



3. Audio Connection: Connect the audio cable from the audio output on the receiver to the input on your amplifier equipment.

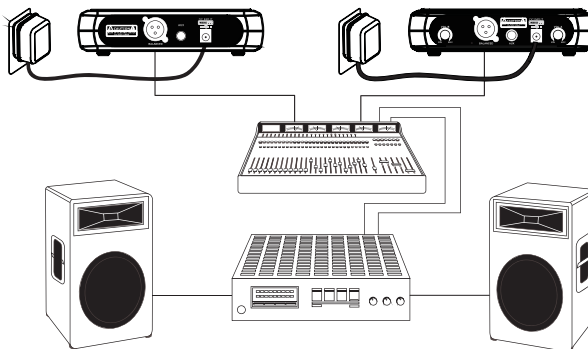

PYLE

BODYPACK TRANSMITTER CONNECTION

1. **Lavalier Microphone Connection:** Connect the connector of supplied Lavalier microphone to the connecting jack of transmitter (Shown as below) Set the transmitter work state in wireless lavalier system.

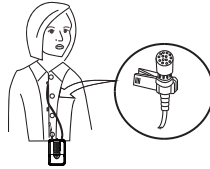
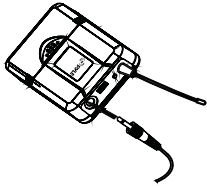

2. **Headset Microphone Connection:** Connect the connector of supplied Headset microphone to the connecting jack of transmitter (Shown as below) Set the transmitter work state in wireless headset system.

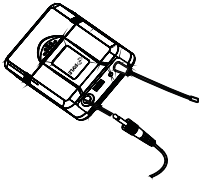

TRANSMITTER BATTERY INSTALLATION

1. **Battery Installation of Transmitter:** Push open the battery cover, insert the supplied batteries into battery jar in polarity and cover the battery Cover.

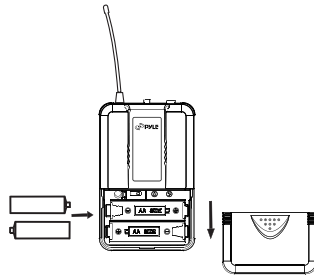
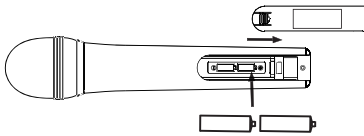

MATCHING WIRELESS FREQUENCY (RECEIVER / TRANSMITTER CONNECTION)

1. Press and hold the "SET" button on the receiver — then release the button once the receiver display begins to flash.
2. When it's flashing, continue to press the "SET" button again to select the desired channel, the selected channel will save automatically without any action for 5 seconds.
3. Power on your microphone/transmitter, press and hold the "UP" and "DOWN" arrow keys once the CH number on display begins to flash.
4. When it is flashing, press "UP" and "DOWN" arrow keys to select the same channel as chosen on receiver, then, the selected channel will save automatically without any action for 5 seconds.
5. Repeat steps 1-4 to connect an additional microphone / transmitter (For models PDWM3375, PDWM3400)

PLYLE

TROUBLESHOOTING

PROBLEM	INDICATOR STATUS	SOLUTION
No Sound	Rod transmitter indicator is not flashing	Slide transmitter POWER ON/OFF switch ON position. Make sure battery is inserted properly, observing battery (+/-). If battery is inserted properly, replace with fresh battery.
	Rod transmitter indicator is flashing	Slide transmitter MUTE/ON switch ON position.
	Red receiver POWER light off	Make sure AC adapter is securely plugged into a electrical outlet and into DC input connector. Make sure AC electrical outlet works and supplies proper voltage.
	Receiver signal indicators A/B lights glowing	Turn up receiver volume control. Confirm that the output connections from the receiver to the external equipment are secure.
	Receiver signal indicators A/B lights off. Transmitter and receiver POWER lights glowing.	Confirm transmitter's and receiver's frequencies matches. Move transmitter closer to the receiver.
Sound level differs from level of cabled instrument	Receiver signal indicators A/B lights glowing	Adjust transmitter gain level to compensatory. Adjust receiver volume as necessary.
Sound level differs with different guitars.	Receiver signal indicators A/B lights glowing.	Re-adjust transmitter gain level to compensate for differences in guitar outputs.
Distortion level increases gradually	Receiver signal indicators A/B lights and transmitter's low battery light glowing	Replace transmitter battery
Bursts of noise or other audible radio signals present	Signal indicators A/B lights on	Identify potential sources of interference (other RF sources) and turn off, remove or use a wireless system operating on a different frequency.
Momentary loss of sound as transmitter is moved around performing area	Receiver signal indicators A/B lights off when sound is lost.	Reposition receiver and perform walk-through test again. If audio dropouts persist, mark "dead" spots and avoid them during performance

UHF WIRELESS MICROPHONE SYSTEM FEATURES AND SPECIFICATIONS

PDWM1902

System Features:

- UHF Microphone Signal Transmission
- Simple Setup & Hassle-Free Operation
- Operation Range: Up to 160'+ ft.
- LED Display for Channel Display & Power Indicator
- Selectable Frequency: (8) Available Audio Channels
- Audio Level Indicator: Displays Wireless Signal Strength
- RF Signal Indicator: Displays Transmitter Signal Strength
- Adjustable Rotary Volume Control
- 1/4" Audio Output Jack
- XLR Balanced Output Jack

Handheld Microphone Specs:

- Includes (1) Wireless Dynamic Mic
- LCD Display with Channel Readout
- RF Output: >10 dBm
- Modulation Type: FM
- Max Deviation: ± 40 KHz
- Spurious Emission: >55 dBc
- Nominal Current Drain: < 40mA
- Battery Operated, Requires: (2) x 'AA' Batteries
- Dimensions: 9.25 x 1.9 x 1.9 in

Receiver Specs:

- Image & Spurious Rejection: >70 dB
- Signal / Noise Ratio: -105dB
- T.H.D.: < 1%
- Audio Output Level: 0-300 mV
- Power Supply: 110/220V (12-15V Power Adapter)
- Dimensions: 6.8 x 5.3 x 1.7 in
- Sold as: Kit
- Weight: 2.62 lbs.



PYLE

PDWM1904

System Features:

- UHF Band Microphone System
- Simple Setup & Hassle-Free Operation
- Operation Range: Up to 160'+ ft.
- LED Display Screens for Audio Channel & Power Indicator
- Audio Level Indicator: Displays Wireless Audio Signal Strength
- RF Signal Indicator: Display Transmitter Signal Strength
- Adjustable Rotary Volume Control
- 1/4" Audio Output Jack
- XLR Balanced Output Jack

What's in the Box:

- Microphone Receiver
- (1) Body-Pack Transmitter
- (1) Headset Mic
- (1) Lavalier Mic

Body-Pack Transmitter Specs:

- RF Output: >10 dBm
- Modulation Type: FM
- Max Deviation: \pm 40 KHz
- Spurious Emission: > 55 dBc
- Nominal Current Drain: < 40mA
- Power Requirements: 2 x 1.5V AA

Receiver Specs:

- Signal / Noise Ratio: -105dB
- Border Upon Channel Rejection: > 70 dB
- T.H.D.: < 1%
- Audio Output Level: 0-300 mV
- Power Supply: 110/220V (12-15V Power Adapter)
- Dimensions 6.8 x 5.3 x 1.7 in
- Sold as: Kit
- Weight: 2.5 lbs.



PYLE

PDWM3375

System Features:

- UHF Band Microphone System
- Simple Setup & Hassle-Free Operation
- Operation Range: Up to 160'+ ft.
- LED Screen Displays Audio Channel & Power Indicator
- Audio level indicator for wireless signal
- RF Signal Indicator for transmitter signal strength
- Independent & adjustable channel volume controls
- Selectable Frequency Range: Up to (8) Channels
- 1/4" Audio Output Jack
- XLR Balanced Output Jack

Receiver Specs:

- Signal / Noise Ratio: -105dB
- Border Upon Channel Rejection: >70dB
- T.H.D.: < 1%
- Audio Output Level: 0-300 mV
- Dimensions 6.8 x 5.3 x 1.7 in

Handheld Mic Specs:

- Includes (2) Wireless Dynamic Microphones
- RF Output: >10 dBm
- Modulation Type: FM
- Max Deviation: \pm 40 KHz
- Spurious Emission: > 55 dBc
- Nominal Current Drain: < 40mA
- Battery Powered, Requires (2) x 'AA' Batteries -Each
- Dimensions: 9.25 x 1.9 x 1.9 in
- Power Supply: 110/220V (12-15V Power Adapter)
- Sold as: Kit
- Weight: 3.12 lbs.



PYLE

PDWM3378

System Features:

- UHF Band Microphone System
- Operation Range: Up to 160'+ ft.
- LED Digital Display Readout Screens
- Simple Setup & Hassle-Free Operation
- AF & RF Audio Transmission Signal Strength Indicators
- Independent & Adjustable Channel Volume Controls
- Selectable Frequency Range: Up to (8) Channels
- 1/4" Audio Output Jack
- XLR Balanced Output Jack

What's in the Box:

- Receiver Base
- Belt pack Transmitter
- Hand held Microphone
- Headset Microphone
- Lavalier Microphone
- Power Cable

Transmitter Specs:

- RF Output: >10 dBm
- Modulation Type: FM
- Max Deviation: ± 40 KHz
- Spurious Emission: > 55 dBc
- Nominal Current Drain: < 40mA
- Battery Powered, Requires (2) x 'AA' Batteries -Each

Receiver Specs:

- Signal / Noise Ratio: -105dB
- Border Upon Channel Rejection: >70dB
- T.H.D.: < 1%
- Audio Output Level: 0-300 mV
- Dimensions 6.8 x 5.3 x 1.7 in
- Power Supply: 110/220V (12-15V Power Adapter)
- Sold as: 1
- Weight: 0 lbs.



PYLE

PDWM3400

System Features:

- UHF Band Microphone Signal System
- Operation Range: Up to 160'+ ft.
- Audio Level Indicator for Wireless Signal Strength
- Independent & Adjustable Channel Volume Controls
- RF Signal Indicator for Transmitter Signal Strength
- LED Power Indicator & Channel Display
- Selectable Frequency Range: Up to (8) Channels
- 1/4" Audio Output Jack
- XLR Balanced Output Jack

What's in the Box:

- Microphone Receiver
- (2) Body-Pack Transmitters
- (2) Headset Microphones
- (2) Lavalier Microphones

Body-Pack Transmitter Specs:

- RF Output: >10dBm
- Modulation Type: FM
- Max Deviation: ± 40 KHz
- Spurious Emission: >55dBc
- Nominal Current Drain: <40mA
- Power Requirements: (2) x 1.5V AA (Not Included)
- Dimensions: 9.25" x 1.9" x 1.9"

Receiver Specs:

- Image & Spurious Rejection: >70 dB
- Signal / Noise Ratio: -105dB
- T.H.D.: < 1%
- Audio Output Level: 0-300 mV
- Power Supply: 110/220V (12-15V, DC Adapter)
- Dimensions 6.8" x 5.3" x 1.7"
- Sold as: Kit
- Weight: 2.94 lbs.



PYLE

PYLE

PyleUSA.com