



EXEDY
RACING CLUTCH

**Performance
Race • Sport**

Clutches & Flywheels

2013-14



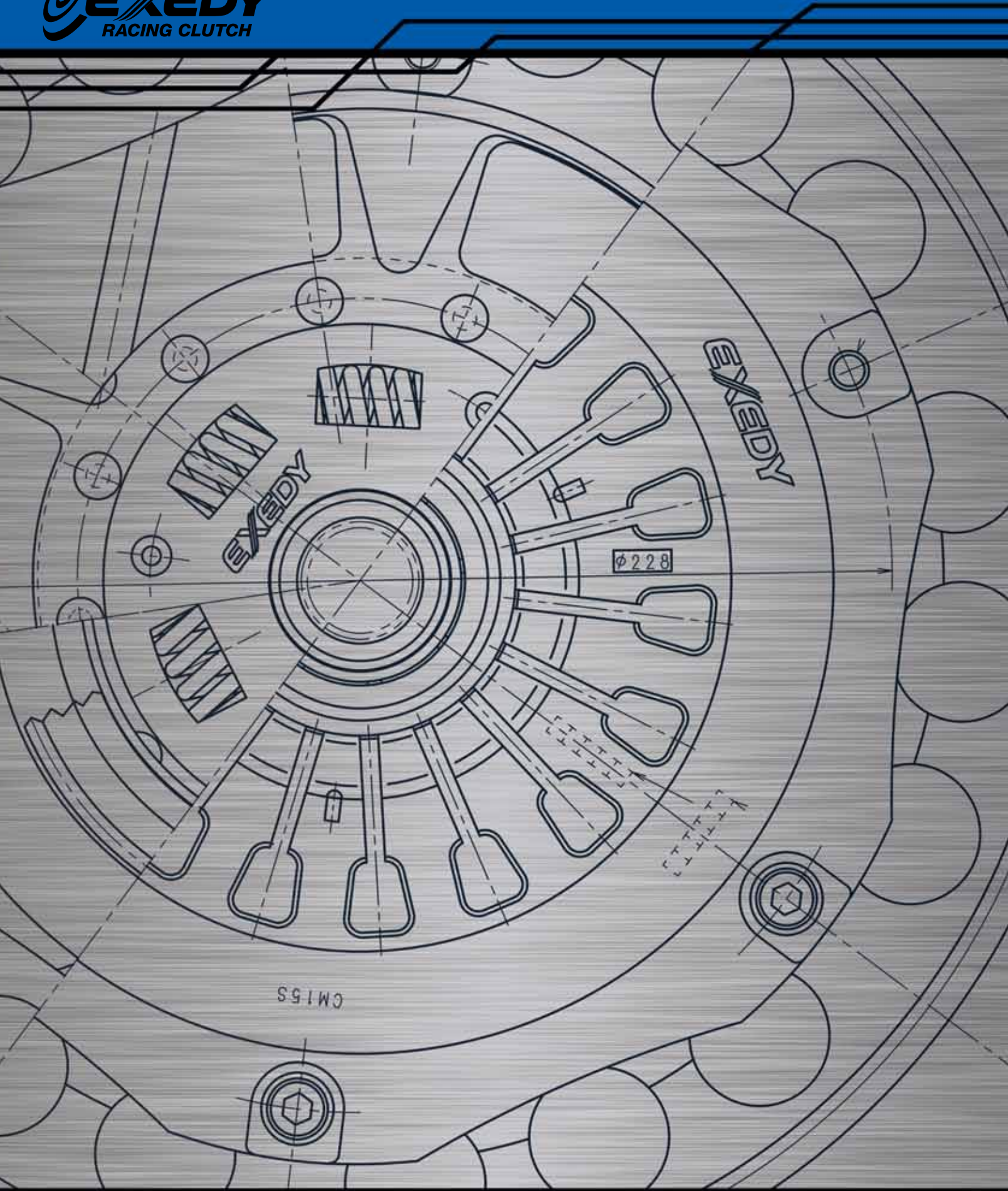

The Pursuit of Excellence

World's Largest Manufacturer of Sports/Performance/Racing Clutch Products. Your prerequisite to WIN!

About Exedy

EXEDY Corporation of Japan (formerly known as Daikin Manufacturing Company) is one of the largest independent OEM suppliers. We supply all of the major Japanese vehicle manufacturer's as well as Ford and GM in the US. We are also the leading manufacturer of racing clutches in Japan and supply all six factory vehicle manufacturer's race teams. Unlike our competitors, our clutches are NOT rebuilt OE, or modified stock clutches. All EXEDY racing and performance clutches are engineered, designed and built from the ground up as race clutches, in the shadow of the OEM products. EXEDY's product innovations are patented worldwide and developed in house using state of the art design, inspection and testing equipment. Before any design goes into production it goes through rigorous tests that simulate severe driving conditions, which ensure perfect performance in your vehicle. Additionally, no part will leave the EXEDY factory without a robotic and visual inspection, which guarantees quality you can stand behind.

Design

In addition to accumulated know-how as a clutch specialist, the latest CAD equipment has been introduced. By utilizing CATIA (3D Design) and FEA (Finite Element Analysis) engineering, the most appropriate designs and configurations are tailored to meet each customer's individual requirements. Diaphragm springs are a key component of the clutch assembly, they are designed and made by EXEDY for ultimate performance.



Inspection

EXEDY Multi Plate Clutches are assembled by hand with the finished products being individually assessed for clamp load and release characteristics ensuring the highest quality at all times.



For the latest updates, information and technical data please visit our website: www.exedyusa.com

Vehicle Test

At the EXEDY test track, various driving conditions, from normal to severe, are evaluated with information being fed back to the clutch design department. In the actual vehicle, clutch systems are tuned to attain the best clutch performance for the given circumstances.



Expert Check

Clutches developed for mass production have been tested in the field before being introduced into the market place. Experts in each category perform a thorough evaluation of performance clutches which ensures the products will be fit for sale after they pass these given tests.



Table of Contents

Terms and Conditions	6
Installation Warning.....	7
Choosing the Correct Clutch	8
Stage 1 - Organic	
Single Plate Clutch	13
Stage 2 - Cerametallic	
Single Plate Clutch	14
Flywheels	15
Stage 3 - Hyper	
Single Plate Clutch	16
Stage 4 & 5 - Hyper	
Multi Plate Clutch	18
Hyper Carbon	
Series Clutch	20
Hyper Carbon-D	
Series Clutch	22
Application Guide	
Stage 1, 2 and Flywheels.....	24
Application Guide	
Hyper Series Clutches	46
Replacement Parts	62
Conversions	68

A large white rectangular area with horizontal lines for writing, set against a background of faint technical drawings and a gear-like pattern.

Terms & Conditions

1. All orders accepted by, and goods/products supplied by, EXEDY GLOBALPARTS CORPORATION, hereafter referred to as the Company, are subject to the following Terms and Conditions of Sale. Any exceptions and/or variations must be specifically agreed to in writing by both parties on sports and performance clutch products, warranties offered by the company on standard clutch products, do not apply to sports and performance clutch products.
2. Manufacturers' Names, Part Numbers, Symbols or any other references appearing in the Company's listing and/ or on the Company Packaging, are used for reference purposes only and in no way indicate the goods/products are made by, for, and/or guaranteed by such manufacturers.
3. All data, applications and/or interchanges, contained in the Company's listing have been compiled as carefully as possible from reliable and official sources of information available at the time of printing and appears as a general guide only. The information contained herein is correct to the best of the Company's knowledge and belief. However, the Company cannot, and will not, assume any responsibility for possible errors contained in this publication.

Correct Selection of Products is the Responsibility of the Purchaser.

4. All goods/products supplied by the Company are warranted against faulty material and/ or workmanship but will not cover maltreatment and damage caused by collision, incorrect fitting or normal wear and tear sustained and which is common in a sports clutch application. Due to the nature of the intended use of these products, they are warranted for 90 days or 6,000 miles from the date of purchase.
5. When the Company's clutch cover, clutch discs, or bearings are repackaged with another manufacturer's parts all warranties are void.
6. Claims will be rejected where clutch kits and/or clutch components have been fitted to incorrect or unlisted applications. Flywheel must be resurfaced/machined before new clutch kit is fitted otherwise warranty will be void.

Claim Warranty Procedures

7. Any goods/product deemed by the customer to be faulty must be accompanied with a completed EXEDY Globalparts Corporation Warranty Claim Form, then the merchandise should be sent to the company freight prepaid or given to a company representative. An RGA may be obtained by phoning our Sales office (an RGA will be given at our discretion). Additional claim forms may be obtained by phoning a customer service representative.
- 7a. In the event the original purchaser of the clutch needs an urgent replacement kit, the purchaser must buy a new clutch kit from the original distributor. EXEDY Globalparts Corporation will credit the price of this clutch if the said part sent in for a warranty claim is found to be faulty. A credit will be issued for the value at distributors pricing. Under no circumstance is the distributor without written authorization from the company to issue a credit to the said purchaser of a faulty clutch.
8. No Claim Credit will be issued until the said goods/products have been tested and deemed faulty by the Company. The Company will not be liable for any labor charges or other expenses incurred nor shall it be liable for any damages or injury to persons or property resulting from misuse or improper installation.
- 9. The Company will not pay any claim for goods/products repaired by the Customer and/or claims sight unseen.**
10. It is the responsibility of the EXEDY distributor to advise his customer on all aspects of this warranty and/or warranty procedures on any claim.
11. All special ordered goods/products will not be accepted back for credit.

Attention

Please read before installation and advise driver of vehicle

All Sports & Performance Clutches & Flywheels

When installing a sports/performance clutch in certain vehicles, there can be an increase in transferred harmonic noises from the engine to the gearbox. This may also cause gearbox rattle. These transmitted noises in no way affect the performance of the clutch or the vehicle, and is accepted in the performance industry, where engine and/or clutch modifications have been carried out.

For example:

Replacing an OEM, EXEDY Silent Design or a long travel clutch disc with a high torque center EXEDY sports/performance clutch disc can be the cause of some additional transmitted noise.

Choosing the Correct Exedy Sports Clutch

1. What vehicle does the customer have? You will want to know the following.

- a. Manufactures exact model and model year.
- b. Engine size and engine code.
- c. If they have altered the vehicle by doing a engine swap or a transmission swap.
- d. If they have updated or back dated any of the engine and/or transmission components.
- e. Good to know information if at all possible
 1. Input shaft size (measure the outer most diameter of the input shaft spline)
 2. Disc size outer diameter
 3. Vehicle chassis code

2. How much power does the vehicle make? Always ask the customer for torque output at the wheels. Horsepower is a very subjective figure so try to avoid using this figure.

- a. If your customer is unsure about their torque output you will need to find out what modifications they have done to the vehicle. Knowing the vehicles base line torque output and basic research on how much additional power each component has added you can figure out the estimated torque output.
- b. Since your estimated torque output will generally be a flywheel torque figure you will want to remove 20% from your estimated torque output to come up with your estimated wheel torque figure.
- c. If the customer has not done any modifications there is no need for a sports/ racing clutch. Sport/racing clutches are intended to handle a increase in torque above and beyond the capacity of the OEM clutch. Sports/racing clutches are not going

Choosing the Correct Exedy Sports Clutch

to last longer than that of a OEM clutch even if the vehicle is stock as that is not the purpose of a sports/racing clutch.

3. What type of driving is the customer going to be doing?

- a. Street driving
- b. Street / Strip / Weekend racer
- c. Dedicated race car

4. Now that we know the vehicle model, torque output and type of driving the vehicle is being used for we can give the customer a good recommendation on clutch type (stage).

- a. EXEDY Stage 1 clutch is great for the customer looking for a very smooth engaging clutch that is going to drive similar to the OEM unit but capable to handle moderate levels of modifications. This is a great option for the "street driver".
- b. EXEDY Stage 2, 3, 4 Cerametallic disc with sprung hub center section is a great choice for the "street / strip / weekend racer" with applications to handle moderate to aggressive levels of modifications. These units offer a very consistent operation whether being raced or daily driven. The sprung hub center offers ease of engagement and absorbs many of the driveline vibrations at idle and during acceleration/deceleration.
- c. EXEDY Stage 4, 5 Cerametallic disc with solid hub center section is a great choice for the "dedicated race car" or very highly modified "street / strip / weekend racer" who doesn't not mind sacrificing drivability for performance. This type of clutch will offer a very consistent operation however chatter and driveline vibrations will be experienced due to the solid hub center section.

Choosing the Correct Exedy Sports Clutch

- d. EXEDY Stage 3, 4 Carbon** disc with sprung hub center section is a great choice for the “dedicated race car” who wants a very smooth engaging clutch with little to no driveline vibrations. The carbon disc is a very lightweight resulting in extremely quick shifts.
- e. EXEDY Stage 3, 4, 5 Carbon** disc with solid hub center section is a great choice for the “dedicated race car” who wants a very smooth engaging clutch that is very lightweight for extremely quick shifts.

***Carbon clutches are not recommended for street use due to the inconsistent friction coefficient from hot to cold. Carbon clutches require a warm up procedure before being driven aggressively. Due to this nature we only recommend carbon clutches for race only applications or to customers who completely understand the characteristics of a carbon clutch. A very big misconception of a carbon clutch is that the vehicle is warm so isn't the clutch? These units work excellent on dedicated race cars due to the driver being able to do the warm up procedure prior to the start of the race and every time driver upshifts or downshifts at higher RPM he is continuing to add heat to the clutch disc. In a street car you often stop at lights, drive in a specific gear, or shift at a lower RPM not allowing adequate heat to be given to the clutch disc. Without heat in a carbon clutch the friction coefficient is significantly lower than when heated. It is at these points in a street car that the customer may decide to put the pedal to the metal causing the clutch to slip and wear out prematurely due to inadequate heat being in the clutch disc.*

5. Lightweight flywheels for the Stage 1, 2 clutch kits are great options to;

- a. Improve throttle response.
- b. Allow the engine to rev more quickly.
- c. Allow the clutch to operate cooler.

Choosing the Correct Exedy Sports Clutch

- d. Burst tested and SFI approved. Rated to 10,000+RPM.
- e. Remove the OEM dual mass flywheels.

All EXEDY lightweight flywheels are made from a one piece forged chromoly steel which utilize a nitrate hardening process, unique cooling ducts and distribute the weight evenly to allow for better drivability on the street.

6. How to set-up and what to expect from an EXEDY sport/racing product.

- a. Break in period should be that of 500 miles of city type driving, double the break in period for highway driving. No aggressive driving. No hole shots or drag launches. Gear changes should be made at 4,000 RPM or less. No speed shifting.
- b. Installing a sports/racing clutch to suit various vehicles can transfer harmonic noises from the engine to the gearbox. This is also called gearbox rattle. This can occur at idle and during acceleration/deceleration.
- c. Clutch engagement can be compromised by installing a sports/racing clutch. This is due to the heavier torsional dampening springs and/or the solid hub center on the clutch disc. Another factor is due to reduction in cushion plate thickness within an organic clutch disc and/or no cushion plate on the cerametallic and carbon clutch discs. The best way to remedy this situation is a take off at a slightly higher RPM and/or let the clutch out a bit quicker.
- d. Since most of the stage 4 and 5 multi-plate clutch kits have a free floating pressure plate and intermediate plate there will be a metal on metal noise when the clutch is depressed. This is common on most multi-plate clutches and is acceptable within the racing industry.

Choosing the Correct EXEDY Sports Clutch

Exedy Racing Hyper Series Clutch Selection Guide

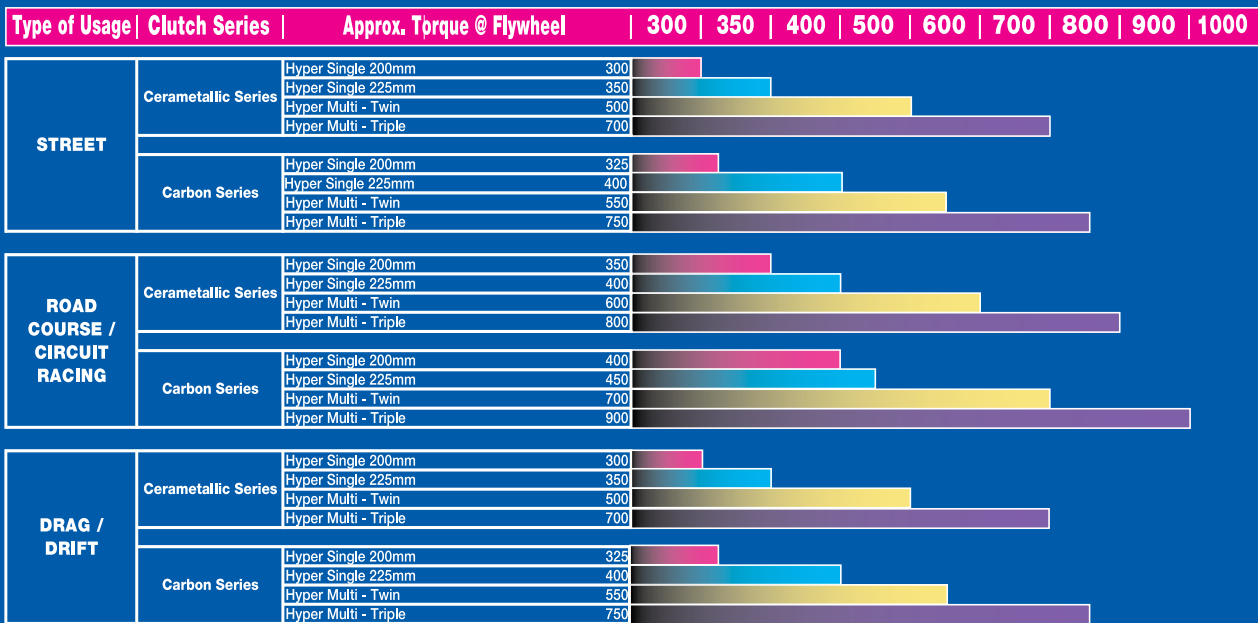

Although these are generally accepted tolerances for our clutches - It should be noted that many additional factors can vary the level of capacity the clutch has. Such factors include but are not limited to: Tire Selection, Tire Pressure, Track Conditions, Gear Ratio, Hydraulic Modification, Axle Ratio, Driving Style, Etc.



SFI CERTIFICATION

SFI Foundation Inc. sets special specifications in automotive parts to protect both the driver and spectator. Many racing organizations and tracks now require SFI specifications for different classes and parts used. In general, as cars produce more power and go faster, these specifications become more and more strict. To ensure our customers can race without risk of disqualification EXEDY has tested and certified many of our clutch kits and flywheels such as Stages 1, 2, 3, 4, 5, Carbon Series and the Lightweight Flywheels.

Stage 1 - Organic Friction Disc

Ultra Fiber Disc

This advanced facing material provides the high heat resistance essential for motorsports. It was developed by reviewing both the copper wire ratio and the composition of the high strength fiber. The Ultra Fiber Disc maintains the superior half-engagement feeling specific to the Organic material. With improved high heat resistance, it provides the functionality essential for street performance and mild racing applications.

Organic Disc

Newly developed asbestos free friction facing is used, which has high heat resistance and high burst strength characteristics. No steel back is required which can cause high RPM "lock-out" and/or synchro damage. Superior in shift operations and half-engagement feel, this clutch disc is recommended for any sports/performance use.

Clutch Cover

These clutch covers are designed to achieve a clamping load that is approx. 40% higher than the genuine part allowing a higher torque transmitting capacity. Ductile material is used for all pressure plates and, high burst strength can be achieved in all temperature ranges.



Stage 2 - Cerametallic Friction Disc

EXEDY cerametallic clutches are designed to handle the abuse of high power modified engines. Our cerametallic friction material can handle much more abuse than stock type disc assemblies without slipping and fading.

All EXEDY Stage 2 cerametallic clutch discs have sprung center dampers to reduce the impact and shock loads transmitted through the drivetrain. We offer two types of cerametallic discs, "thick" and "thin."

Thick Disc

The "thick" discs have better heat capacity and therefore better durability in demanding applications. Even with the "thick" disc, our three and four puck designs typically have less inertia than a stock disc and work well for street, rally and track use.

Thin Disc

The "thin" discs offer greatly reduced inertia to improve shift effort, allow for quicker shifting, and improve synchro durability. These discs are approximately 1/2 the thickness of a stock disc and are recommended for circuit track use only.

Flywheels - Lightweight One Piece Chromoly

EXEDY flywheels combine low weight, low inertia and high thermal capacity. They are designed for lightly tuned racing cars for drag racing, autocross and rally events, as well as street usage. They are made from solid one-piece billet chromoly steel or chromoly steel forgings. They are specifically designed to reduce weight and inertia for better engine response. Most incorporate special design features to enhance the airflow which improves the cooling of the clutch. The ring gear teeth are integrated onto the flywheel unlike an aluminum flywheel where the ring gear is pressed onto the flywheel and has the possibility of separating from the flywheel due to the different expansion coefficients of aluminum versus steel. EXEDY steel billet and forged steel flywheels have passed engineering tests to 15,000-18,000 rpm. They are guaranteed not to fail to the said rpm, and are all SFI approved.



Stage 3

HYPER *Single*

The Hyper Single Clutch is engineered to optimize the performance of cars that are moderately modified, but do not require the clutch capacity of a multi-plate clutch. Similar to our multi-plate clutches, it has a purple anodized, forged aluminum cover. The aluminum cover is stiffer than a stamped cover and therefore allows a higher lever ratio to maintain the pedal efforts at a reasonable level. There is no clamp load deflection as found in a pressed metal type cover.

All Hyper Single clutches come with a chromoly steel flywheel, 6-puck cerametallic facing and a spring center damper disc assembly. The disc is generally smaller and thinner than the OEM disc making for lower inertia and therefore quicker, easier shifting and less wear and tear on the transmission synchros. The higher clamp load and cerametallic friction facings give approximately twice the holding torque of the OEM clutch and generally higher than other single plate clutches. An additional feature of the pressure plate is a series of turbine-like, air flow enhancing vanes that keep the clutch cooler under extreme operating conditions to improve wear life.

- High friction coefficient, low wear, and a special heat resistant material (T5001) has been developed enabling clutch size to be reduced and increased durability to be achieved.
- Durability is improved with the use of a stronger, smaller damper disc, specifically redesigned for the Hyper Single Clutch.
- A lower level of inertia is achieved over the genuine fitment clutch which improves shift response for faster gear changes particularly for racing applications.



Pull Type Clutch

The pull type clutch accommodates higher torque, in conjunction with lighter pedal efforts to produce a superior clutch operation, when adapted to most high-powered vehicles. An EXEDY Original design.

Advantages

- Unlike the push type cover, when a pull type cover flexes, it will flex in the direction of disengagement, assisting in positive pedal feel.
- A longer lever ratio achieves a direct decrease in pedal effort.

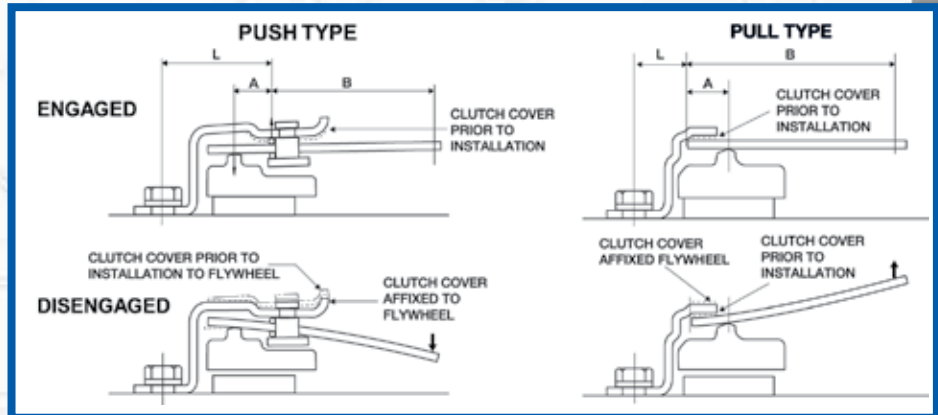

Patented One Touch Snap in Function

The problem of detachment difficulties is solved by the use of EXEDY original one-touch snap in bearing design. Detachment can easily be accomplished with the use of a screwdriver, alternatively, the bearing can be snapped back into place while activating the release fork.

What is Inertia?

Inertia is the tendency of the clutch and flywheel to maintain rotation even when not connected to the engine torque. This affects the responsiveness of the engine and also the feel of low rpm torque and start up driveability.

In the case of the clutch disc, lower inertia is always better to improve shift efforts and reduce the wear on the transmission synchros.

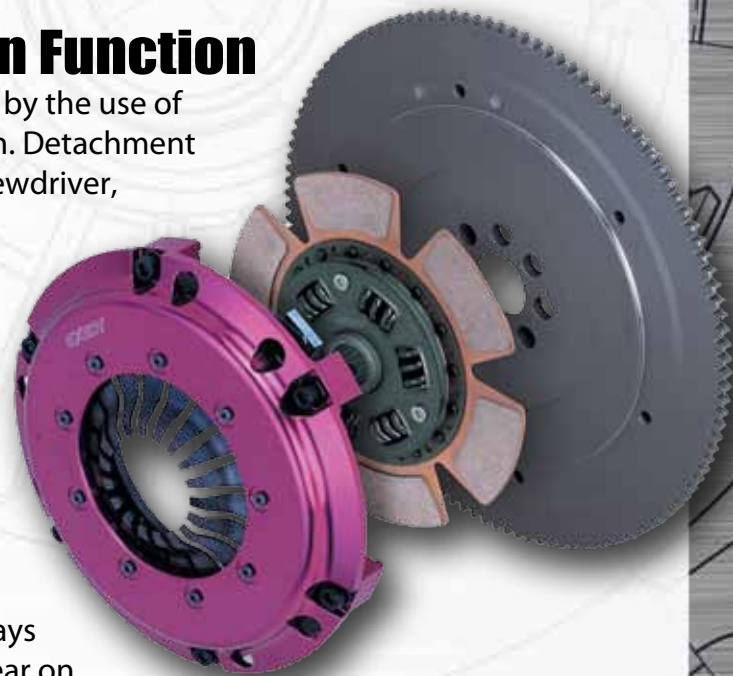

Stage 4 & 5

HYPER *Multi Plate*

Twin and Triple Plate

For high-powered applications, EXEDY offers twin and triple Multi-Plate Clutches. These are designed for high power street action as well as drag, road and rally racing.

The twin plate clutches are rated for approximately 500 ft.lbs. TQ @ FW. The triple plate clutches are rated for up to and over 800 ft.lbs. TQ @ FW. Twins come with both spring damper discs or solid discs depending on application. Triples are all solid discs and not recommended for street use.

All of our multi-plate clutches come with a lightweight, chromoly steel flywheel and the famous purple anodized forged aluminum clutch cover. Depending on the application, we have both strap drive and lug drive models. All have T5001 cerametallic friction materials for extreme heat resistance.

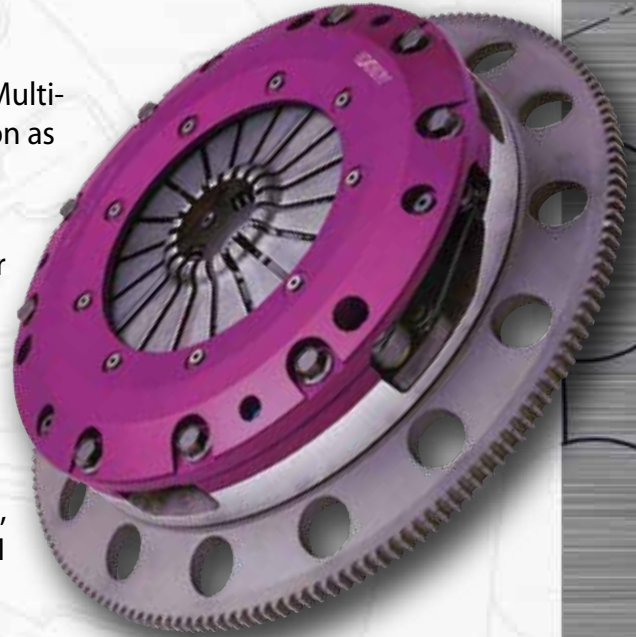

SD Type

This model has been developed for high powered street cars and race cars with up to approximately 600TQ @ FW. They feature ventilated, thick intermediate plates for improved life and spring damper discs to protect your transmission and drive line.

600TQ @ FW. The combination of ultra lightweight solid discs and a lightweight chromoly flywheel gives the driver a lightened pedal effort and quick response. This can improve your times when running at the drag strip or road course. They feature ventilated, thick intermediate plates for improved life.

SR Type

This model has twin or triple plates developed to be lightweight for quick response. The Triple plate model is available for over 800TQ @ FW and the twin plate model is rated to approximately

HR Type

This model has three plates and is developed specifically for high power applications such as over 800TQ @ FW for drag racing. It handles high torque loads and shifts smooth, and because of the lightweight clutch discs, you can reduce your shift times.

Patented Clutch Cushioning Function

The “cushion” function is a new innovation unique to EXEDY. The half engaged “zone” is expanded as a result of a decrease in rigidity of the pivot ring. Ideal pedal effort is achieved as a result of a longer lever ratio of the diaphragm spring coupled with the cushion reaction force.

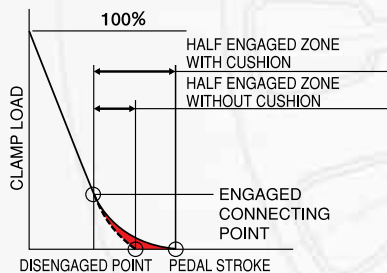
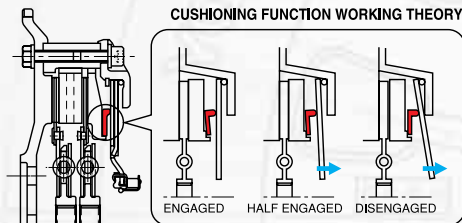

Engine Modifications

Cam, timing, turbo modifications etc., cause engine pulsation and vibrations. These vibrations can cause clutch rattle when the clutch pedal is depressed by movement on the intermediate separator plate, in some applications. These noises will in no way affect the performance of the EXEDY Multi Plate Clutch. This rattle is well accepted in the performance industry where engine modifications have been carried out.

Patented Center Plate Self Leveling Function

The amount of center plate travel during release is always maintained in a neutral position by the reaction force of the lifting plate attached to both sides of the center plate.

- Improved disengagement (accelerated separation from friction surface).
- Improved disc life by eliminating unbalanced wear at the T/M and F/W side.
- Prevents and lowers mechanical noise.

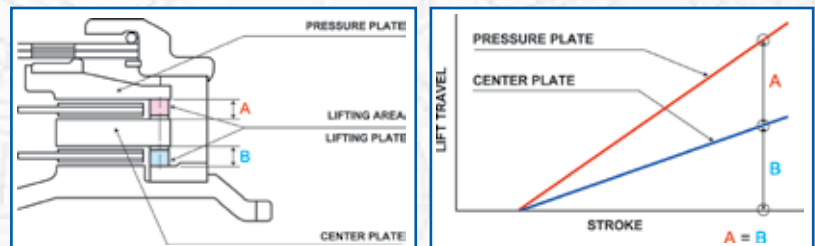

Working Theory

Due to high temperatures generated by the clutch system during operation, the pressure plate tends to absorb a large portion of that heat, accelerating the wear of the pressure plate side disc. The Lifting plate location remains steady between the location area on the pressure plate shown as (A) and F/W location area shown as (B) on the chart above. Accordingly, the wear of the pressure plate side disc is accelerated, resulting in the F/W side disc automatically being engaged earlier than the pressure plate side, which in turn increases the F/W side disc’s work and wear rate. Therefore, due to an increase in workload during half engaged operations, wear on the F/W side disc will be accelerated causing a reduction in the overall friction material thickness, resulting in the F/W disc registering a similar thickness friction material to that on the pressure plate side.

HYPER *Carbon Series*

The flagship model of EXEDY clutches, the Carbon Steel Multi Plate Clutch. These Clutches are lightweight, durable and resilient to high heat, contributing to an improvement in track times.

Warm Up Procedure

Due to the inherent properties of the carbon material, we must specify the proper way to bring the discs up to operating temperature.

This Process will heat the discs so they will hold the specified torque rating. The correct method is three, five second "slips" of the clutch within 30 seconds at low RPM.

High Heat Resistance

Carbon materials are baked at more than 3600°F, which allows the carbon material to dissipate heat far better than conventional metallic material. Heat expansion rate is 1/20th of iron therefore eliminating a change in clutch feel that may happen due to distortion caused by expansion during driving. Carbon material not only has a high heat resistance but also a "non-stick" characteristic that eliminates disengagement problems.

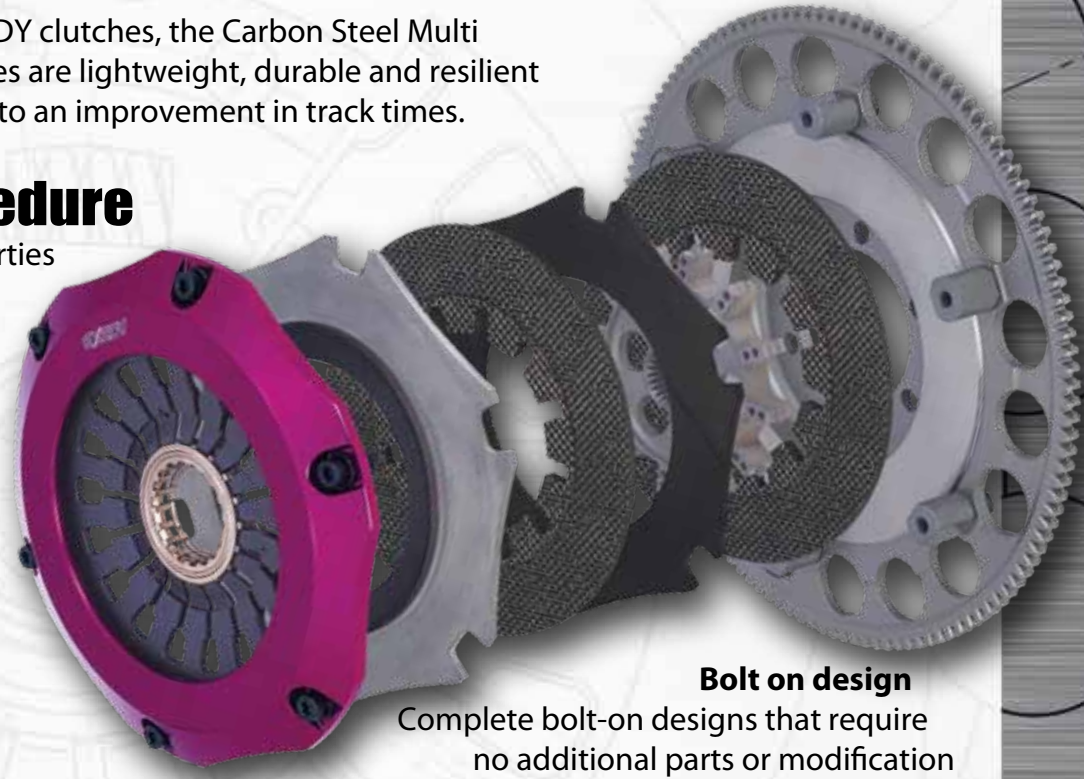

Bolt on design

Complete bolt-on designs that require no additional parts or modification



Light in Weight

The heaviest components of the clutch system are the clutch cover, intermediate plates and flywheel. Semi-Carbon clutches incorporate an improved cover configuration and lightened flywheel also contributing to a reduction in vehicle rotating weight.

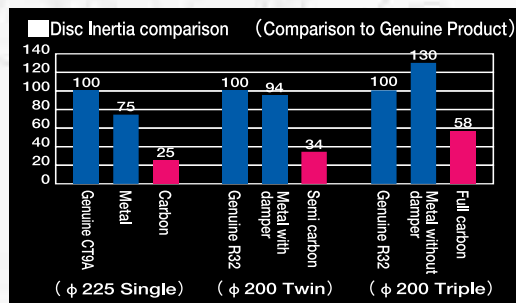

Low Inertia Design

The weight of a carbon clutch disc is one third that of a metallic disc. Utilizing a high friction coefficient Hyper Carbon disc which allows for quicker shift response. Low inertia discs allow the transmission to synchronize in a shorter space of time eliminating time loss during shift changing while also reducing the applied load to the synchronizer.

Easy to Handle

By controlling the carbon fibers and baking temperature, the cross layer type carbon material, which is the most appropriate for high revolution strength and high torque transmission, is applied to tuning car clutches. Semi-carbon clutches offer lightweight, high heat resistance and a stable friction coefficient.

EXEDY Carbon clutches are tuned so that at a lower temperature, engagement feeling is improved and conversely at high temperatures, engagement is ideal for spirited driving.

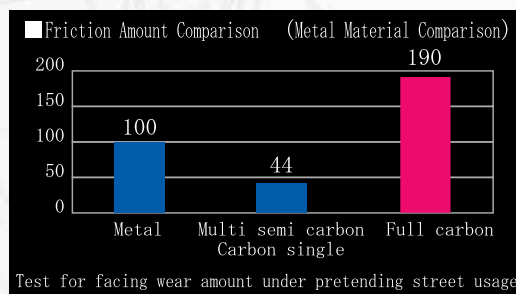
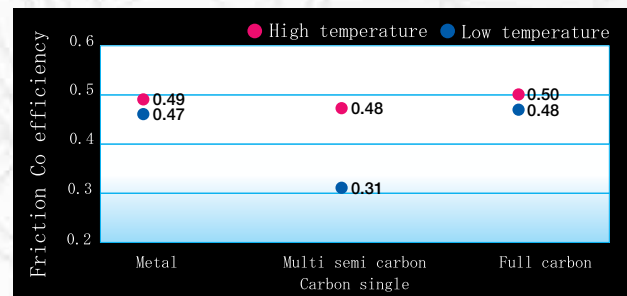

Long Life

Semi-Carbon clutches allow double the life when compared to conventional metallic type material, which equates to an improved cost performance thanks to longer overhaul cycles. Full carbon clutches have more wear than metallic however, when used with over-sized pressure plates, the life is identical to metallic.

HYPER *Carbon Series-D*

Introducing the Next Generation ...

...of clutch systems by EXEDY – Carbon-D,
the revolutionary Carbon Clutch System.

Carbon-D was developed to achieve the ultimate goal of comfort and streetability by absorbing noise and vibration emitted from drivetrain components such as the differential, transmission and engine. The Carbon-D system is designed to protect the drivetrain by absorbing and dissipating “shock torque” by utilizing EXEDY Patented Technology. Superior engineering enables the Carbon-D clutch system to possess an ideal clutch engagement position, increased clamp loads and lower pedal effort, while the unique Carbon Fiber friction material allows comfortable half-engaged clutch operation and responsive gear changes.



Carbon-D Single

- Introduction of a damper to absorb and dissipate noise and vibration
- High clamp load, lower pedal effort and ideal clutch engagement is obtained with the use of the re-engineered diaphragm spring
- Quiet Strap Drive design to minimize mechanical noise

Patent Pending Disc System

Carbon-D Twin

- Introduction of a damper to absorb and dissipate noise and vibration
- With a reduction in pedal effort and an increase in disc size to 225mm, the Carbon-D Twin clutch is ideally suited to high performance street vehicles
- By optimizing the weight and inertia of the Carbon-D Clutch System, driveability is improved at low speeds



Gear Noise and Fluctuations in Engine Rotation (rpm)

Even engines that seem to run very smoothly always have some amount of fluctuation in engine rotation. These fluctuations, when transferred from the engine to the transmission, cause gear teeth carrying no torque to strike mating teeth, resulting in noise (“tooth hammer”). The noise is louder in the interior as well as outside the vehicle because the clutch housing acts as a speaker and magnifies the noise. Although the noise level and noise-generating speed depend on the type and model of car, such noise is more frequent in a 6-speed vehicle than in a 5-speed vehicle.

Vibration-Absorbing Damper

The conventional damper used in most sports clutches is designed to protect the transmission from shock torque caused by abrupt clutch engagement, so it does little to absorb vibration. Efficient absorption of fluctuations in engine speed requires a very flexible spring and proper setting of the hysteresis torque. The flexibility of the spring, however, is likely to run counter to the damper capacity. For this reason, Carbon-D is equipped with a new dual stage damper, a low-load stage and rapid-acceleration stage, both of which are perfectly tuned for each car type. This tuning technology is available only from EXEDY, the specialist in high performance clutch systems.

Stage 1 - Stage 2 - Flywheels

Stage 1 & 2 clutches have a 10-30% higher pedal effort than stock due to higher clamp load.
Stage 2 thin are for circuit track only! Not for street, rally or drag use.

Application	Engine Size	Year	Engine Code	Clamp Load	STAGE 1				STAGE 2 Thick Pad			
					Kit Part #	Clutch Torque	Flywheel TQ@	Wheels TQ@	Kit Part #	Clutch Torque	Flywheel TQ@	Wheels TQ@
Acura												
CL	2.2L/2.3L	97-99	F22B1/F23	1542	08805	298	238	191	08952	355	276	221
					---	---	---	---	NEW 08952P4	355	276	221
Integra	1.8L	90-91	B18A1	1538	08804	297	233	187	08953	355	271	221
Integra	1.7L/1.8L	92-93	B17A/B18A	1538	08800A	297	233	187	08950A	355	271	217
					---	---	---	---	NEW 08950AP4	355	271	217
Integra	1.8L	94-01	B18B/B18C	1538	08800B	297	233	187	08950B	355	271	217
					---	---	---	---	NEW 08950BP4	355	271	217
RSX Type S	2.0L	02-07	K20	1596	08806	303	241	193	08951	361	280	224
					---	---	---	---	NEW 08951P4	361	280	224
RSX	2.0L	02-07	K20	1596	08806	303	241	193	08951	361	280	224
					---	---	---	---	NEW 08951P4	361	280	224
<i>RSX (non Type S) Flywheel must be changed to HF02 when using performance clutch kit (#08806, #08951, #08951P4)</i>												
TSX	2.4L	03-08	K24	1596	08806	303	241	193	08951	361	280	224
					---	---	---	---	NEW 08951P4	361	280	224
<i>Must change Flywheel to HF02 when using performance clutch kit (#08806, #08951, #08951P4)</i>												
Chevrolet												
Camaro SS	6.2L	10-Up	LS-3	3372	04804	820	622	498	04953	1014	640	533
Cavalier	2.3L/ 2.4L	95-99	LD9	1785	04800	349	277	222	---	---	---	---
Cobalt	2.2L	05-10	L61	1866	04801	360	290	232	04950	435	337	270
Cobalt SS	2.4L	05-10	---	1866	04801	360	290	232	04950	435	337	270
Corvette	5.7L	97-04	LS-1/LS-6	3372	04805FW	820	622	498	04954FW	1014	640	533
<i>Must change flywheel to GF502 when using performance clutch kit (#04805FW, #04954FW)</i>												
Corvette	6.0L	05-08	LS-2	3372	04803	820	622	498	04952	1014	640	533
Corvette	7.0L	06-10	LS-7	3372	04803	820	622	498	04952	1014	640	533
Corvette	6.2L	09-Up	LS-3	3372	04803	820	622	498	04952	1014	640	533
HHR	2.4L	06-07	---	1866	04801	360	290	232	04950	435	337	270
Nova	1.6L	85-88	4ALC	1212	16804B	212	169	133	16954B	253	196	157

STAGE 2 Thin Pad				Disc Size (mm)	Splines Teeth/ Major Dia (mm)	Light Weight Flywheel		Notes	Standard Clutch Kit Part #
Kit Part #	Clutch Torque	Flywheel TQ@	Wheels TQ@			Part #	Weight (lb)		
08901	355	276	221	220	24T/26	---	---	---	08014
---	---	---	---	220	24T/26	---	---	4 Puck design disc	08014
08903	355	275	220	220	24T/25	HF01	9.5	Cable Type Clutch	08017
08900A	355	275	220	220	24T/26	HF01	9.5	GSR/VTEC, Cable Clutch	08028
---	---	---	---	220	24T/26	HF01	9.5	4 Puck design disc, GSR/VTEC, Cable Clutch	08028
08900B	355	275	220	220	24T/26	HF01	9.5	Hydraulic Clutch	KHC05
---	---	---	---	220	24T/26	HF01	9.5	4 Puck design disc	KHC05
08905	361	307	246	215	24T/26	HF02	8.9	6 Speed	KHC10
---	---	---	---	215	24T/26	HF02	8.9	6 Speed, 4 Puck design disc	KHC10
08905	361	307	246	215	24T/26	HF02	8.9	5 Speed, RSX (non Type S) Flywheel must be changed to HF02 when using performance clutch kit (#08806, #08951)	KHC09
---	---	---	---	215	24T/26	HF02	8.9	4 Puck design disc, 5 Speed, RSX (non Type S) Flywheel must be changed to HF02 when using performance clutch kit (#08806, #08951, #08951P4)	KHC09
08905	361	307	246	215	24T/26	HF02	8.9	6 Speed, RSX (non Type S) Flywheel must be changed to HF02 when using performance clutch kit (#08806, #08951)	HCK1001
---	---	---	---	215	24T/26	HF02	8.9	4 Puck design disc, 6 Speed, Must change Flywheel must be changed to HF02 when using performance clutch kit (#08806, #08951, #08951P4)	HCK1001
---	---	---	---	290	26T/29.4	GF502	---	Kit includes the CSC Hydraulic Slave Cylinder Assembly (BRG0175)	GMK1036
---	---	---	---	225	14T/25	---	---	---	04158
---	---	---	---	225	14T/25	GF501	10.5	Natural aspirated, Does not include CSC Hydraulic Slave Cylinder (BRG0143)	GMK1010
---	---	---	---	225	14T/25	GF501	10.5	Natural aspirated, Does not include CSC Hydraulic Slave Cylinder (BRG0143)	GMK1010
---	---	---	---	280	26T/29	GF502	---	Cushion Button type Stage 2 Disc, C5, 6 Speed, Must change flywheel to GF502 when using performance clutch kit (#04805FW, #04954FW), Includes Flywheel	04173
---	---	---	---	290	26T/29.4	GF502	---	Kit includes the CSC Hydraulic Slave Cylinder Assembly, C6, 6 Speed (BRG0167)	GMK1035
---	---	---	---	290	26T/29.4	GF502	---	Kit includes the CSC Hydraulic Slave Cylinder Assembly (BRG0167)	GMK1035
---	---	---	---	290	26T/29.4	GF502	---	Kit includes the CSC Hydraulic Slave Cylinder Assembly (BRG0167)	GMK1035
---	---	---	---	225	14T/25	GF501	10.5	Natural aspirated, Does not include CSC Hydraulic Slave Cylinder (BRG0143)	GMK1010
---	---	---	---	200	21T/24.1	---	---	Fuel Injected	16042

Stage 1 - Stage 2 - Flywheels

Application	Engine Size	Year	Engine Code	Clamp Load	STAGE 1				STAGE 2 Thick Pad				
					Kit Part #	Clutch Torque	Flywheel TQ@	TQ@ Wheels	Kit Part #	Clutch Torque	Flywheel TQ@	TQ@ Wheels	
Chrysler													
Conquest	2.6L	88-90	G54B	1895	10803B	250	310	248	10952B	298	361	295	
Conquest	2.6L	88-90	G54B	2360	10803BHD	486	387	310	10952BHD	580	450	360	
<i>If 1988-90 flywheel is used, these clutches can be applied to 1984-87 models (originally 225mm clutch)</i>													
Dodge													
Colt Vista	2.4L	92-94	4G64	2136	05800	413	329	264	05950	492	381	305	
					---	---	---	---	NEW 05950P4	492	381	305	
Stealth	3.0L	91-96	6G72	2136	05800	413	329	264	05950	492	381	305	
					---	---	---	---	NEW 05950P4	492	381	305	
Ram Truck	5.9L	01-04	---	3260	---	---	---	---	CRK1004HD	1085	816	680	
Ram Truck	5.9L	05-07	---	3260	---	---	---	---	CRK1005FWHD	1085	816	680	
Eagle													
Summit	2.4L	92-96	4G64	2136	05800	413	329	264	05950	492	381	305	
					---	---	---	---	NEW 05950P4	492	381	305	
Talon	2.0L	90-94	4G63	1544	05801	283	225	180	05950	492	381	305	
					---	---	---	---	NEW 05950P4	492	381	305	
Talon	2.0L	90-4/92	4G63T	2136	05800	413	329	264	05950	492	381	305	
					---	---	---	---	NEW 05950P4	492	381	305	
Talon	2.0L	5/92-98	4G63T	2136	05800	413	329	264	05950	492	381	305	
					---	---	---	---	NEW 05950P4	492	381	305	
Talon	2.0L	90-4/92	4G63T	2136	05800	413	329	264	05950	492	381	305	
					---	---	---	---	NEW 05950P4	492	381	305	
Talon	2.0L	5/92-98	4G63T	2136	05800	413	329	264	05950	492	381	305	
					---	---	---	---	NEW 05950P4	492	381	305	
Ford													
Escort/ZX2	2.0L	97-03	Zetec	1543	10801	298	238	191	10958	356	276	221	
Focus	2.0L	00-04	Zetec	---	---	---	---	---	07958	---	---	---	
F250-F350	7.3L	99-03	---	2997	---	---	---	---	FMK1008HD	998	816	680	
Focus	2.0/2.3L	04-07	Duratec	1566	07804	241	241	193	07954	361	280	224	
<i>OEM Flywheel (Dual Mass Flywheel) must be changed to ZF502 when using performance clutch Kit (#07804, #07954) Also need 6-crank bolts (part #</i>													
Focus	2.0L	02-04	---	---	07808	---	298	248	07957	---	335	279	
Fusion	2.3L	06-07	L3-VE	1543	10807	302	242	202	10956	361	276	221	

STAGE 2 Thin Pad				Disc Size (mm)	Splines Teeth/ Major Dia (mm)	Light Weight Flywheel		Notes	Standard Clutch Kit Part #
Kit Part #	Clutch Torque	Flywheel TQ@	Wheels TQ@			Part #	Weight (lb)		
10902B	298	361	295	236	23T/26.2	---	---	Turbo	05049
---	---	---	---	236	23T/26.2	---	---	Turbo	05049
05900	---	347	278	225	20T/22.4	---	---	---	05048A
---	---	---	---	225	20T/22.4	---	---	4 Puck design disc	05048A
05900	---	347	278	225	20T/22.4	---	---	2WD, Non-Turbo	05048
---	---	---	---	225	20T/22.4	---	---	4 Puck design disc, 2WD, Non-Turbo	05048
---	---	---	---	330	10T/35	---	---	Turbo Diesel, 6spd, Cushion Button Disc	---
---	---	---	---	330	10T/35	---	---	6 Spd Turbo Diesel, Solid FW replacement for OEM Dual Mass FW, Includes Master and Slave Cylinder Hydraulic system, Includes Solid Flywheel, Cushion Button disc	---
05900	---	347	278	225	20T/22.4	---	---	Including Wagon	05071
---	---	---	---	225	20T/22.4	---	---	4 Puck design disc, Including Wagon	05071
---	---	---	---	215	20T/22.4	---	---	Non-Turbo	05051
---	---	---	---	215	20T/22.4	---	---	4 Puck design disc, Non-Turbo	05051
05900	---	347	278	225	20T/22.4	---	---	Turbo 2WD, 6 Bolt Crank	05048
---	---	---	---	225	20T/22.4	---	---	4 Puck design disc, Turbo 2WD, 6 Bolt Crank	05048
05900	---	347	278	225	20T/22.4	---	---	Turbo 2WD, 7 Bolt Crank	05048
---	---	---	---	225	20T/22.4	---	---	4 Puck design disc, Turbo 2WD, 7 Bolt Crank	05048
05900	---	347	278	225	20T/22.4	MF03	12.0	Turbo AWD, 6 Bolt Crank	05048
---	---	---	---	225	20T/22.4	MF03	12.0	4 Puck design disc, Turbo AWD, 6 Bolt Crank	05048
05900	---	347	278	225	20T/22.4	MF01	12.0	Turbo AWD, 7 Bolt Crank	05048
---	---	---	---	225	20T/22.4	MF01	12.0	4 Puck design disc, Turbo AWD, 7 Bolt Crank	05048
---	---	---	---	225	22T/24.3	---	---	SOHC/DOHC	07083
---	---	---	---	228	23T/25.4	---	---	DOHC, Includes CSC	KFM01
---	---	---	---	330	10T/35	---	---	Turbo Diesel, 6 Spd with direct fuel injection. Exedy/Daikin version includes solid FW. This kit must be installed as a matched set, Includes Cushion Button disc	---
---	---	---	---	225	23T/26.2	ZF502	12.5	OEM Flywheel (Dual Mass Flywheel) must be changed to ZF502 when using performance clutch Kit (#07804, #07954) Also need 6-crank bolts (part #1S7Z-6379-AA) from Dealer.	FMK1009
<i>1S7Z-6379-AA) from Dealer.</i>									
---	---	---	---	225	14T/25	---	---	SVT, 6 Speed	FMK1005
---	---	---	---	225	22T/24.3	ZF502	12.5	---	FMK1004

Stage 1 - Stage 2 - Flywheels

Application	Engine Size	Year	Engine Code	Clamp Load	STAGE 1				STAGE 2 Thick Pad				
					Kit Part #	Clutch Torque	Flywheel TQ@	TQ@ Wheels	Kit Part #	Clutch Torque	Flywheel TQ@	TQ@ Wheels	
Ford continued													
Mustang	5.0L	86-95	---	2608	07800	586	438	365	07950	699	498	415	
Mustang	5.0L	86-95	---	2608	07801	586	438	365	07951	699	498	415	
Mustang	4.6L	96-04	---	2765	07805	639	510	408	07955	763	576	461	
					---	---	---	---	07955P	763	576	461	
				2765	07806	639	510	408	07956	763	576	461	
					---	---	---	---	07956P	763	576	461	
Mustang	4.6L	96-04	---	3372	07802	780	622	498	07952	930	734	587	
					---	---	---	---	07952P	930	734	587	
Mustang	4.6L	96-04	---	3372	07803	780	622	498	07953	930	734	587	
					---	---	---	---	07953P	930	734	587	
Mustang	4.6L	05-10	---	2765	07805CSC	639	510	408	07955CSC	763	576	461	
					---	---	---	---	07955PCSC	763	576	461	
				2765	07806CSC	639	510	408	07956CSC	763	576	461	
					---	---	---	---	07956PCSC	763	576	461	
Mustang	4.6L	05-10	---	3372	07803CSC	780	622	498	07953CSC	930	734	587	
					---	---	---	---	07953PCSC	930	734	587	
Mustang	4.6L	05-10	---	3372	07802CSC	780	622	498	07952CSC	930	734	587	
					---	---	---	---	07952PCSC	930	734	587	
Mustang	5.4L	07-11	---	3372	---	---	---	---	07953FW	930	734	587	
					---	---	---	---	07953PFW	930	734	587	
Mustang GT	5.0L	2011	---	3372	07807CSC	780	622	498	07959CSC	930	734	587	
					---	---	---	---	07959PCSC	---	734	587	
Probe	2.2L	89-92	FE2/FE3	1895	10803A	250	310	248	10952A	298	361	295	
Probe	2.2L	89-92	FE2/FE3	2360	10803AHD	486	387	310	10952AHD	580	450	360	

STAGE 2 Thin Pad				Disc Size (mm)	Spline Teeth/ Major Dia (mm)	Light Weight Flywheel		Notes	Standard Clutch Kit Part #
Kit Part #	Clutch Torque	TQ@ Flywheel	TQ@ Wheels			Part #	Weight (lb)		
---	---	---	---	265	10T/27.5	See Notes	---	EF504 (50oz. counter weight), EF505 (28oz. counter weight)	07042
---	---	---	---	265	26T/29	See Notes	---	Tremec Transmission, EF504 (50oz. counter weight), EF505 (28oz. counter weight)	---
---	---	---	---	280	10T/27.5	EF503 (6 Bolt)	16.1	GT, Shelby GT, Bullitt, Cushion Button Disc	FMK1011
---	---	---	---	280	10T/27.5	EF502 (8 Bolt)	16.1	GT, Shelby GT, Bullitt, Paddle Style Disc	FMK1011
---	---	---	---	280	26T/29	EF503 (6 Bolt)	16.1	GT, Shelby GT, Bullitt, Tremec Transmission, Cushion Button Disc	FMK1012
---	---	---	---	280	26T/29	EF502 (8 Bolt)	16.1	GT, Shelby GT, Bullitt, Tremec Transmission, Paddle Style Disc	FMK1012
---	---	---	---	280	10T/27.5	EF503 (6 Bolt)	16.1	Cobra, GT, Mach-1, Cushion Button Disc	KFM10
---	---	---	---	280	10T/27.5	EF502 (8 Bolt)	16.1	Cobra, GT, Mach-1, Paddle Style Disc	KFM10
---	---	---	---	280	26T/29	EF503 (6 Bolt)	16.1	Tremec Transmission, Cushion Button Disc	---
---	---	---	---	280	26T/29	EF502 (8 Bolt)	16.1	Tremec Transmission, Paddle Style Disc	---
---	---	---	---	280	10T/27.5	EF503 (6 Bolt)	16.1	GT, Shelby GT, Bullitt, Cushion Button Disc	FMK1011
---	---	---	---	280	10T/27.5	EF502 (8 Bolt)	16.1	GT, Shelby GT, Bullitt, Paddle Style Disc	FMK1011
---	---	---	---	280	26T/29	EF503 (6 Bolt)	16.1	GT, Shelby GT, Bullitt, Tremec Transmission, Cushion Button Disc	FMK1012
---	---	---	---	280	26T/29	EF502 (8 Bolt)	16.1	GT, Shelby GT, Bullitt, Tremec Transmission, Paddle Style Disc	FMK1012
---	---	---	---	280	26T/29	EF503 (6 Bolt)	16.1	Tremec Transmission, Cushion Button Disc, Includes Hydraulic Concentric slave cylinder	FMK1012
---	---	---	---	280	26T/29	EF502 (8 Bolt)	16.1	Tremec Transmission, Paddle Style Disc, Includes Hydraulic Concentric slave cylinder	FMK1012
---	---	---	---	280	10T/27.5	EF503 (6 Bolt)	16.1	Cobra, GT, Mach-1, Cushion Button Disc, Includes Hydraulic Concentric slave cylinder	FMK1011
---	---	---	---	280	10T/27.5	EF502 (8 Bolt)	16.1	Cobra, GT, Mach-1, Paddle Style Disc, Includes Hydraulic Concentric slave cylinder	FMK1011
---	---	---	---	---	---	EF502 (8 Bolt)	16.1	Shelby GT500/GT500KR, Cushion Button disc, Includes CSC Hydraulic Slave Cylinder, Includes Flywheel	---
---	---	---	---	---	---	EF502 (8 Bolt)	16.1	Shelby GT500/ GT500KR, Paddle Style disc, Includes CSC Hydraulic Slave cylinder, Includes Flywheel	---
---	---	---	---	280	23T/26.2	EF502 (8 Bolt)	16.1	Cushion Button Stage 2 disc, Includes Hydraulic Concentric Slave Cylinder	---
---	---	---	---	280	23T/26.2	EF502 (8 Bolt)	16.1	Paddle Style Stage 2 disc, Includes Hydraulic Concentric Slave Cylinder	---
10902A	298	361	295	236	23T/26.2	---	---	Turbo	07067
---	---	---	---	236	23T/26.2	---	---	Turbo	07067

Stage 1 - Stage 2 - Flywheels

Application	Engine Size	Year	Engine Code	Clamp Load	STAGE 1				STAGE 2 Thick Pad			
					Kit Part #	Clutch Torque	Flywheel TQ@	TQ@ Wheels	Kit Part #	Clutch Torque	Flywheel TQ@	TQ@ Wheels
GEO												
Prizm	1.6L	89-4/91	4AFE	1212	16804B	212	169	133	16954B	253	196	157
Prizm	1.6L	5/91-92	4AFE	1212	16804C	212	169	133	16954C	253	196	157
Prizm	1.6L	90-97	4AFE	1543	16800	283	225	180	16950	337	261	209
Prizm	1.8L	93-97	3TC	1543	16800	283	225	180	16950	337	261	209
Honda												
Accord	2.2L	90-97	F22	1542	08805	298	238	191	08952	355	276	221
					---	---	---	---	NEW 08952P4	355	276	221
Accord	2.3L	90-02	F23	1542	08805	298	238	191	08952	355	276	221
					---	---	---	---	NEW 08952P4	355	276	221
Accord	2.4L	03-07	K24	1596	08806	303	241	193	08951	361	280	224
					---	---	---	---	NEW 08951P4	361	280	224
<i>Must change Flywheel to HF02 when using performance clutch Kit (# 08806, #08951, #08951P4, #08905)</i>												
Civic	1.5L	88	D15	991	08802	181	138	111	---	---	---	---
Civic	1.5L	89	D15	991	08803	181	138	111	---	---	---	---
<i>If the HF501 is used, the higher capacity clutch can be used (# 08801B, #08902B)</i>												
Civic	1.5L	90-91	D15	1454	08801B	184	227	182	---	---	---	---
Civic	1.5L	92-95	D15	1454	08801A	184	227	182	---	---	---	---
Civic	1.6L	89	D16	991	08803	---	138	111	---	---	---	---
<i>If the HF501 is used, the higher capacity clutch can be used (# 08801B, #08902B)</i>												
Civic	1.6L	90-91	D16	1454	08801B	184	227	182	---	---	---	---
Civic	1.6L	92-00	D16	1454	08801A	184	227	182	---	---	---	---
Civic	1.7L	01-05	D17	1454	08801A	184	227	182	---	---	---	---
Civic SI	1.6L	99-00	B16A	1538	08800B	297	233	187	08950B	355	271	217
					---	---	---	---	NEW 08950BP4	355	271	217
Civic SI	2.0L	02-09	K20	1596	08806	303	241	193	08951	361	280	224
					---	---	---	---	NEW 08951P4	361	280	224
<i>Vehicles with 5 speed transmission must change flywheel to HF02 for performance clutch kit (# 08806, #08951, #08951P4, #08905).</i>												
Civic Wagon	1.5L	88	D15	991	08802	181	138	111	---	---	---	---
Civic Wagon	1.5L	89	D15	991	08803	181	138	111	---	---	---	---
<i>If the HF501 is used, the higher capacity clutch can be used (# 08801B, #08902B)</i>												
Civic Wagon	1.5L	90-91	D15	1454	08801B	184	227	182	---	---	---	---
Civic Wagon	1.6L	90-91	D16	1454	08801C	184	227	182	---	---	---	---
CRX	1.5L	88	D15	991	08802	181	138	111	---	---	---	---

STAGE 2 Thin Pad				Disc Size (mm)	Spline Teeth/ Major Dia (mm)	Light Weight Flywheel		Notes	Standard Clutch Kit Part #
Kit Part #	Clutch Torque	TQ@ Flywheel	TQ@ Wheels			Part #	Weight (lb)		
---	---	---	---	200	21T/24.1	---	---	SOHC	16070
---	---	---	---	200	21T/24.1	---	---	SOHC	16070
---	---	---	---	215	21T/24.1	---	---	---	KTY03
---	---	---	---	215	21T/24.1	---	---	---	KTY03
08901	355	276	221	220	24T/26	---	---	---	08014
---	---	---	---	220	24T/26	---	---	4 Puck design disc	08014
08901	355	276	221	220	24T/26	---	---	---	HCK1000
---	---	---	---	220	24T/26	---	---	4 Puck design disc	HCK1000
08905	361	307	246	215	24T/26	HF02	8.9	---	HCK1001
---	---	---	---	215	24T/26	HF02	8.9	4 Puck design disc, Must change Flywheel to HF02 when using performance clutch Kit (#08806, #08951, #08951P4, #08905)	HCK1001
---	---	---	---	200	21T/22	---	---	---	08009
---	---	---	---	200	20T/22	---	---	If the HF501 is used, the higher capacity clutch can be used (# 08801B, #08902B)	08011
08902B	322	266	213	212	20T/22	HF501	10.9	---	08012
08902A	322	266	213	212	20T/22	HF501	10.9	---	08022
---	---	---	---	200	20T/22	---	---	If the HF501 is used, the higher capacity clutch can be used (# 08801B, #08902B)	08011
08902B	322	266	213	212	20T/22	HF501	10.9	SOHC	08012
08902A	322	266	213	212	20T/22	HF501	10.9	SOHC	08022
08902A	322	266	213	212	20T/22	HF501	10.9	SOHC	KHC08
08900B	322	275	220	220	24T/26	HF01	9.5	VTEC/DOHC	KHC05
---	---	---	---	220	24T/26	HF01	9.5	4 Puck design disc, VTEC/DOHC	KHC05
08905	361	307	246	215	24T/26	HF02	8.9	5 speed, 6 speed, (Vehicles with 5 speed transmission must change flywheel to HF02 for performance clutch kit (# 08806, #08951, #08905)).	KHC10
---	---	---	---	215	24T/26	HF02	8.9	4 Puck design disc, 5 speed, 6 speed, (Vehicles with 5 speed transmission must change flywheel to HF02 for performance clutch kit (# 08806, #08951, #08951P4, #08905)).	KHC10
---	---	---	---	200	21T/22	---	---	2WD	08009
---	---	---	---	200	20T/22	---	---	If the HF501 is used, the higher capacity clutch can be used (# 08801B, #08902B)	08011
08902B	322	266	213	212	20T/22	HF501	10.9	2WD	08012
08902C	322	266	213	212	20T/22	HF501	10.9	AWD	08020
---	---	---	---	200	21T/22	---	---	---	08009

Stage 1 - Stage 2 - Flywheels

Application	Engine Size	Year	Engine Code	Clamp Load	STAGE 1				STAGE 2 Thick Pad			
					Kit Part #	Clutch Torque	Flywheel TQ@	TQ@ Wheels	Kit Part #	Clutch Torque	Flywheel TQ@	TQ@ Wheels
Honda continued												
CRX	1.5L	89	D15	991	08803	181	138	111	---	---	---	---
<i>If the HF501 is used, the higher capacity clutch can be used (# 08801B, #08902B)</i>												
CRX	1.5L	90-91	D15	1454	08801B	184	227	182	---	---	---	---
CRX	1.6L	88	D16	991	08802	181	138	111	---	---	---	---
CRX	1.6L	89	D16	991	08803	181	138	111	---	---	---	---
<i>If the HF501 is used, the higher capacity clutch can be used (# 08801B, #08902B)</i>												
CRX	1.6L	90-91	D16	1454	08801B	184	227	182	---	---	---	---
Del Sol	1.5/1.6L	93-95	D15/D16	1454	08801A	184	227	182	---	---	---	---
Del Sol	1.6L	96-97	D16	1454	08801A	184	227	182	---	---	---	---
<i>Must change flywheel to HF501 for performance clutch kit (# 08801A, #08902A).</i>												
Del Sol	1.6L	94-97	B16A	1538	08800B	297	233	187	08950B	355	271	217
					---	---	---	---	NEW 08950BP4	355	271	217
Fit	1.5L	06-08	L15A1	1259	08807	208	166	133	08954	249	197	158
Prelude	2.2L	92-01	F22/H22	1542	08805	298	238	191	08952	355	276	221
					---	---	---	---	NEW 08952P4	355	276	221
Prelude	2.3L	92-96	H23A	1542	08805	298	238	191	08952	355	276	221
					---	---	---	---	NEW 08952P4	355	276	221
Infiniti												
G20	2.0L	91-96	SR20DE	1544	06802	289	230	184	---	---	---	---
G35	3.5L	03-07	VQ35DE	2271	06804	481	383	307	06952	574	444	355
<i>Recommended for use with Exedy Solid Flywheel (NF04), will also work with OE Dual-Mass Flywheel.</i>												
G35	3.5L	03-07	VQ35DE	2271	06804FW	481	383	307	06952FW	574	444	355
G37	3.7L	08	VQ37VHR	2271	06807	481	383	307	06956	574	444	355
Lexus												
ES250	2.5L	90-91	2VZFE	2093	16803C	431	343	275	16953C	515	399	319
ES300	3.0L	92-93	3VZFE	2093	16803A	431	343	275	16953A	515	399	319
Lotus												
ELISE	1.8L	05-07	2ZZ-GE	1543	16800	283	225	180	16950	328	261	209
EXIGE	1.8L	06-07	2ZZ-GE	1543	16800	283	225	180	16950	328	261	209
Mazda												
Mazda 3	2.0/2.3L	04-07	LF-DE/ L3-VE	1566	10809	302	241	193	10955	351	280	224
Mazda 5	2.3L	06-08	---	1566	10809	302	241	193	10955	351	280	224
Mazda 6	2.3L	03-08	L3-VE	1543	10807	298	238	191	10956	346	276	221
Mazda 6	3.0L	03-08	AJV	1978	10808	407	324	259	---	---	---	---
626/MX6	2.2L	88-92	F2	1895	10803A	390	310	248	10952A	435	361	295
626/MX6	2.2L	88-92	F2	2360	10803AHD	486	387	310	10952AHD	564	450	360

STAGE 2 Thin Pad				Disc Size (mm)	Splines Teeth/ Major Dia (mm)	Light Weight Flywheel		Notes	Standard Clutch Kit Part #
Kit Part #	Clutch Torque	TQ@ Flywheel	TQ@ Wheels			Part #	Weight (lb)		
---	---	---	---	200	20T/22	---	---	If the HF501 is used, the higher capacity clutch can be used (# 08801B, #08902B)	08011
08902B	322	266	213	212	20T/22	HF501	10.9	---	08012
---	---	---	---	200	21T/22	HF501	10.9	Fuel Injected	08010
---	---	---	---	200	20T/22	---	---	If the HF501 is used, the higher capacity clutch can be used (# 08801B, #08902B)	08011
08902B	322	266	213	212	20T/22	HF501	10.9	---	08012
08902A	322	266	213	212	20T/22	HF501	10.9	SOHC	08022
08902A	322	266	213	212	20T/22	HF501	10.9	S, Si, SOHC, Must change flywheel to HF501 for performance clutch kit (# 08801A, #08902A).	08031
08900B	355	275	220	220	24T/26	HF01	9.5	VTEC/DOHC	KHC05
---	---	---	---	---	24T/26	HF01	9.5	4 Puck design disc, VTEC/DOHC	KHC05
---	---	---	---	190	20/22.2	---	---	L15A1	HCK1006
08901	355	276	221	220	24T/26	---	---	---	KHC03
---	---	---	---	---	24T/26	---	---	4 Puck design disc	KHC03
08901	355	276	221	220	24T/26	---	---	---	KHC03
---	---	---	---	---	24T/26	---	---	4 Puck design disc	KHC03
06902	345	209	167	215	18T/20.6	---	---	---	KNS02
---	---	---	---	250	24T/25.6	NF04	19.6	Coupe and Sedan (6 Speed only), Recommended for use with Exedy Solid Flywheel (NF04), will also work with OE Dual-Mass Flywheel.	NSK1000
---	---	---	---	250	24T/25.6	NF04	19.6	Coupe and Sedan (6 Speed only), Includes NF04 Flywheel	NSK1000FW
---	---	---	---	250	24T/25.6	NF05	19.6	Kit includes Flywheel, DOES NOT include CSC Hydraulic Slave Cylinder (BRG0163)	---
---	---	---	---	240	21T/29.8	---	---	---	16082
---	---	---	---	240	21T/29.8	---	---	---	16082
---	---	---	---	215	21T/24.1	---	---	---	---
---	---	---	---	215	21T/24.1	---	---	---	---
---	---	---	---	225	22T/24.3	ZF501	13.0	Non-Turbo	MZK1003
---	---	---	---	225	22T/24.3	ZF501	13.0	Non-Turbo	MZK1003
---	---	---	---	225	22T/24.3	ZF502	12.5	Non-Turbo	MZK1000
---	---	---	---	240	23T/26.2	ZF503	16.5	---	MZK1001
10902A	435	361	295	236	23T/26.2	---	---	Turbo	07067
---	---	---	---	236	23T/26.2	---	---	Turbo	07067

Stage 1 - Stage 2 - Flywheels

Application	Engine Size	Year	Engine Code	Clamp Load	STAGE 1				STAGE 2 Thick Pad			
					Kit Part #	Clutch Torque	Flywheel TQ@	TQ@ Wheels	Kit Part #	Clutch Torque	Flywheel TQ@	TQ@ Wheels
Mazda continued												
929	3.0L	88-91	JE	1895	10803A	390	310	248	10952A	435	361	295
929	3.0L	88-91	JE	2360	10803AHD	486	387	310	10952AHD	564	450	360
Miata	1.6L	90-93	B6-ZE	---	10804	204	163	131	10950	237	189	152
<i>If later model 1.8L flywheel is used, the higher capacity 1.8L clutch (# 10805, #10950) can be used</i>												
MX-5 Miata	1.8L	94-05	BP-ZE	1322	10805	256	204	164	10951	297	236	189
MX-5 Miata	2.0L	06-08	VE	1543	10810	298	238	191	---	---	---	---
Protégé	2.0L	04	FS-DE/ZE	1543	10807	298	238	191	10956	346	276	221
Protégé	2.0L	03-04	FS-DET	1543	10807	298	238	191	10956	346	276	221
RX-7	1.2/1.3L	84-91	12A/13B	1574	10806	304	242	196	10954	405	322	258
RX-7	1.3L	86-91	13B-RE	1895	10803A	390	310	248	10952A	435	361	295
RX-7	1.3L	86-91	13B-RE	2360	10803AHD	486	387	310	10952AHD	564	450	360
<i>When using ZF01 flywheel in vehicles built prior to 1/89 use adapter/counterweight N327-11-521A. Vehicles after 1/89 use adapter/counterweight N351-11-521.</i>												
RX-7	1.3L	93-95	13B-REW	2093	10802	431	343	275	10953	501	400	320
RX-7	1.3L	93-95	13B-REW	2653	10802HD	546	435	348	10953HD	635	506	405
<i>When using ZF01 flywheel, use adapter/counterweight N351-11-521.</i>												
RX-8	1.3L	03-07	13B-MSP	1895	10803A	390	310	248	10952A	435	361	295
RX-8	1.3L	03-07	13B-MSP	2360	10803AHD	486	387	310	10952AHD	564	450	360
<i>When using ZF01 flywheel, use adapter/counterweight N3Z2-11-52X.</i>												
Mazda Truck												
B2600	2.6L	87-89	G6	1895	10803A	390	310	248	10952A	435	361	295
B2600	2.6L	87-89	G6	2360	10803AHD	486	387	310	10952AHD	564	450	360
Mercury												
Milan	2.3L	06-07	L3-VE	1543	10807	298	238	191	10956	346	276	221
Mitsubishi												
3000GT	3.0L	91-99	6G72	2136	05800	412	329	264	05950	479	381	305
					---	---	---	---	NEW 05950P4	479	381	305
Eclipse	2.0L	90-94	4G63	1544	05801	283	225	180	05951	328	261	209
Eclipse	2.0L	90-4/92	4G63T	2136	05800	412	329	264	05950	479	381	305
					---	---	---	---	NEW 05950P4	479	381	305
Eclipse	2.0L	5/92-99	4G63T	2136	05800	412	329	264	05950	479	381	305
					---	---	---	---	NEW 05950P4	479	381	305
Eclipse	2.0L	90-4/92	4G63T	2136	05800	412	329	264	05950	479	381	305
					---	---	---	---	NEW 05950P4	479	381	305

STAGE 2 Thin Pad				Disc Size (mm)	Spline Teeth/ Major Dia (mm)	Light Weight Flywheel		Notes	Standard Clutch Kit Part #
Kit Part #	Clutch Torque	Flywheel TQ@	Wheels TQ@			Part #	Weight (lb)		
10902A	435	361	295	236	23T/26.2	---	---	---	10032
---	---	---	---	236	23T/26.2	---	---	---	10032
10903	237	189	152	200	22T/24.3	---	---	If later model 1.8L flywheel is used, the higher capacity 1.8L clutch (# 10805, #10950) can be used	10036
10901	297	236	189	215	22T/24.3	ZF505	---	Includes Mazdaspeed version	KMZ03
---	---	---	---	215	23T/26.2	ZF501	13.0	6spd	MZK1006
---	---	---	---	225	22T/24.3	---	---	---	KMZ08
---	---	---	---	225	22T/24.3	---	---	Mazdaspeed Turbo	---
---	---	---	---	225	22T/24.3	---	---	---	10038
10902A	435	361	295	236	23T/26.2	ZF01	12.0	Turbo, FC3S, When using ZF01 flywheel in vehicles built prior to 1/89 use adapter/counterweight N327-11-521A. Vehicles after 1/89 use adapter/counterweight N351-11-521.	10037
---	---	---	---	236	23T/26.2	ZF01	12.0	Turbo, FC3S, When using ZF01 flywheel in vehicles built prior to 1/89 use adapter/counterweight N327-11-521A. Vehicles after 1/89 use adapter/counterweight N351-11-521.	10037
10900	501	400	320	236	23T/26.4	ZF01	12.0	Turbo, FD3S, When using ZF01 flywheel, use adapter/counterweight N351-11-521.	KMZ01
10900	501	400	320	236	23T/26.4	ZF01	12.0	Turbo, FD3S, When using ZF01 flywheel, use adapter/counterweight N351-11-521.	KMZ01
10902A	435	361	295	236	23T/26.2	ZF01	12.0	When using ZF01 flywheel, use adapter/counterweight N322-11-52X.	MZK1002
---	---	---	---	236	23T/26.2	ZF01	12.0	When using ZF01 flywheel, use adapter/counterweight N322-11-52X.	MZK1002
---	---	---	---	236	23T/26.2	---	---	Carbureted	07067
---	---	---	---	236	23T/26.2	---	---	Carbureted	07067
---	---	---	---	225	22T/24.3	ZF502	12.5	---	FMK1004
05900	479	347	278	225	20T/22.4	---	---	2WD, Non-Turbo	05048
---	---	---	---	225	20T/22.4	---	---	4 Puck design, 2WD, Non-Turbo	05048
---	---	---	---	215	20T/22.4	---	---	Non-Turbo	05051
05900	479	347	278	225	20T/22.4	---	---	2WD Turbo, 6 Bolt Crank	05048
---	---	---	---	225	20T/22.4	---	---	4 Puck design, 2WD Turbo, 6 Bolt Crank	05048
05900	479	347	278	225	20T/22.4	---	---	2WD Turbo, 7 Bolt Crank	05048
---	---	---	---	225	20T/22.4	---	---	4 Puck design disc, 2WD Turbo, 7 Bolt Crank	05048
05900	479	347	278	225	20T/22.4	MF03	12.0	AWD Turbo, 6 Bolt Crank	05048
---	---	---	---	225	20T/22.4	MF03	12.0	4 Puck design disc, AWD Turbo, 6 Bolt Crank	05048

Stage 1 - Stage 2 - Flywheels

Application	Engine Size	Year	Engine Code	Clamp Load	STAGE 1				STAGE 2 Thick Pad			
					Kit Part #	Clutch Torque	Flywheel TQ@	TQ@ Wheels	Kit Part #	Clutch Torque	Flywheel TQ@	TQ@ Wheels
Mitsubishi continued												
Eclipse	2.0L	5/92-99	4G63T	2136	05800	412	329	264	05950	479	381	305
					---	---	---	---	NEW 05950P4	479	381	305
Eclipse	2.4L	96-99	4G64	2136	05800	412	329	264	05950	479	381	305
					---	---	---	---	NEW 05950P4	479	381	305
Eclipse Spyder	2.0L	96-99	4G63T	2136	05800	412	329	264	05950	479	381	305
					---	---	---	---	NEW 05950P4	479	381	305
Eclipse Spyder	2.4L	96-99	4G64	2136	05800	412	329	264	05950	479	381	305
					---	---	---	---	NEW 05950P4	479	381	305
Eclipse Spyder	3.0L	00-05	6G72	1653	05804	341	272	218	05953	396	315	352
Expo/Expo LRV	2.4L	92-95	4G64	2136	05800	412	329	264	05950	479	381	305
					---	---	---	---	NEW 05950P4	479	381	305
Galant	2.0L	91-92	4G63T	2136	05800	412	329	264	05950	479	381	305
					---	---	---	---	NEW 05950P4	479	381	305
Galant	2.4L	94-97	4G64	2136	05800	412	329	264	05950	479	381	305
					---	---	---	---	NEW 05950P4	479	381	305
Lancer Evo 4-7	2.0L	01-02	4G63T	3012	05803	620	495	396	05952	721	575	460
<i>Must use MF04 for this application</i>												
Lancer Evo 4-7	2.0L	01-02	4G63T	3597	05803HD	741	590	472	05952HD	860	685	548
<i>Must use MF04 for this application</i>												
Lancer Evo 8/MR/9	2.0L	03-07	4G63T	3012	05803	620	495	396	05952	721	575	460
Lancer Evo 8/MR/9	2.0L	03-07	4G63T	3597	05803HD	741	590	472	05952HD	860	685	548
Lancer Evo 10	2.0L	08-Up	4B11	3012	05803A	620	495	396	05952A	721	575	460
Lancer Evo 10	2.0L	08-Up	4B11	3597	05803AHD	741	590	472	05952AHD	860	685	548
Starion	2.6L	88-90	G54B	1895	10803B	390	310	248	10952B	453	361	295
Starion	2.6L	88-90	G54B	2360	10803BHD	486	387	310	10952BHD	564	450	360

If 1988-90 flywheel is used, these clutches can be applied to 1984-87 models (originally 225mm clutch)

Nissan												
200 SX	2.2L	82-83	Z22E	1798	06805A	347	276	221	06953A	403	320	256
200 SX	2.0L	95-99	SR20DE	1544	06802	289	230	184	---	---	---	---
200 SX	3.0L	87-88	VG30	2017	06801A	422	335	268	06955A	490	390	312
240SX	2.4L	89-6/90	KA24E	1798	06805A	347	276	221	06953A	403	320	256
240SX	2.4L	7/90-1/94	KA24DE	1798	06805B	347	276	221	06953B	403	320	256
240SX	2.4L	2/94-2/96	KA24DE	1798	06805A	347	276	221	06953A	403	320	256
240SX	2.4L	3/96-98	KA24DE	1798	06805B	347	276	221	06953B	403	320	256
280 Z	2.8L	75-78	L28E	1798	06805A	347	276	221	06953A	403	320	256
280 Z	2.8L	75-78	L28	2017	06801A	422	335	268	06955A	496	390	312
280 ZX	2.8L	79-83	L28E	1798	06805A	347	276	221	06953A	403	320	256
280 ZX	2.8L	79-83	L28E	2017	06801A	422	335	268	06955A	496	390	312
280 ZX	2.8L	82-83	L28ET	2017	06801A	422	335	268	06955A	496	390	312

STAGE 2 Thin Pad				Disc Size (mm)	Splines Teeth/ Major Dia (mm)	Light Weight Flywheel		Notes	Standard Clutch Kit Part #
Kit Part #	Clutch Torque	TQ@ Flywheel	TQ@ Wheels			Part #	Weight (lb)		
05900	479	347	278	225	20T/22.4	MF01	12.0	AWD Turbo, 7 Bolt Crank	05048
---	---	---	---	225	20T/22.4	MF01	12.0	4 Puck design disc, AWD Turbo, 7 Bolt Crank	05048
05900	479	347	278	225	20T/22.4	---	---	---	05048
---	---	---	---	225	20T/22.4	---	---	4 Puck design disc	05048
05900	479	347	278	225	20T/22.4	---	---	2WD Turbo, 7 Bolt Crank	05048
---	---	---	---	225	20T/22.4	---	---	4 Puck design disc, 2WD Turbo, 7 Bolt Crank	05048
05900	479	347	278	225	20T/22.4	---	---	---	05048
---	---	---	---	225	20T/22.4	---	---	4 Puck design disc	05048
---	---	---	---	236	23T/26.2	---	---	Pull Type	KMB02/ MBK1003
05900	479	347	278	225	20T/22.4	---	---	---	05048
---	---	---	---	225	20T/22.4	---	---	4 Puck design disc	05048
05900	479	347	278	225	20T/22.4	MF03	12.0	DOHC, Turbo, VR4	05048
---	---	---	---	225	20T/22.4	MF03	12.0	4 Puck design disc, DOHC, Turbo, VR4	05048
05900	479	347	278	225	20T/22.4	---	---	---	05048
---	---	---	---	225	20T/22.4	---	---	4 Puck design disc	05048
---	---	---	---	240	23T/26.2	MF04	12.0	Non- US Model, Must use MF04 for this application	MBK1002
---	---	---	---	240	23T/26.2	MF04	12.0	Non- US Model, Must use MF04 for this application	MBK1002
---	---	---	---	240	23T/26.2	MF04	12.0	Pull Type, 5 Speed, 6 Speed	MBK1001
---	---	---	---	240	23T/26.2	MF04	12.0	Pull Type, 5 Speed, 6 Speed	MBK1001
---	---	---	---	240	23T/26.2	MF05	12.0	Pull Type, 5 Speed, 6 Speed	MBK1009
---	---	---	---	240	23T/26.2	MF05	12.0	Pull Type, 5 Speed, 6 Speed	MBK1009
10902C	453	323	269	236	23T/26.2	---	---	Turbo	05049
---	---	---	---	236	23T/26.2	---	---	Turbo, If 1988-90 flywheel is used, these clutches can be applied to 1984-87 models (originally 225mm clutch)	05049
---	---	---	---	225	24T/25.6	---	---	SOHC	06004
06902	342	209	167	215	18T/20.6	---	---	---	KNS02
06900A	490	470	376	240	24T/25.6	---	---	---	06031
---	---	---	---	225	24T/25.6	---	---	SOHC	06009
---	---	---	---	225	24T/25.6	---	---	DOHC	06054
---	---	---	---	225	24T/25.6	---	---	DOHC	06009
---	---	---	---	225	24T/25.6	---	---	DOHC	06054
---	---	---	---	225	24T/25.6	---	---	2 Seater & Non-Turbo Only	06009
06900A	496	470	376	240	24T/25.6	---	---	2+2	06030
---	---	---	---	225	24T/25.6	---	---	2 Seater & Non-Turbo Only	06009
06900A	496	470	376	240	24T/25.6	---	---	2+2	06030
06900A	496	470	376	240	24T/25.6	---	---	Turbo	06031

Stage 1 - Stage 2 - Flywheels

Application	Engine Size	Year	Engine Code	Clamp Load	STAGE 1				STAGE 2 Thick Pad				
					Kit Part #	Clutch Torque	TQ@ Flywheel	TQ@ Wheels	Kit Part #	Clutch Torque	TQ@ Flywheel	TQ@ Wheels	
Nissan conintued													
300 ZX	3.0L	84-86	VG30T	2017	06801A	422	335	268	06955A	496	390	312	
300 ZX	3.0L	84-89	VG30	2017	06801A	422	335	268	06955A	496	390	312	
300 ZX	3.0L	90-96	VG30DE	2017	06801B	422	335	268	06955B	496	390	312	
300 ZX	3.0L	90-96	VG30DETT	2021	06806	428	437	364	06954	511	496	413	
350Z	3.5L	03-06	VQ35DE	2271	06804	480	383	307	06952	574	444	355	
<i>Recommended for use with Exedy Solid Flywheel (NF04), will also work with OE Dual-Mass Flywheel</i>													
350Z	3.5L	03-06	VQ35DE	2271	06804FW	480	383	307	06952FW	574	444	355	
350Z	3.5L	07	VQ35HR	2271	06807	480	383	307	06956	574	444	355	
370Z	3.7L	09	VQ37VHR	2271	06807	480	383	307	06956	574	444	355	
810	2.4L	77-81	L24E	1798	06805A	347	276	221	06953A	403	320	256	
Altima	3.5L	02-06	VQ35DE	2271	06804A	480	383	307	06952A	574	444	355	
Bluebird	2.0L	90-98	SR20DET	1765	06803A	369	295	236	06950A	429	343	275	
Maxima	2.4L	81-84	L24E	1798	06805A	347	276	221	06953A	403	320	256	
Maxima	2.8L	82-84	LD28	1798	06805A	347	276	221	06953A	403	320	256	
Maxima	3.0L	85-01	VG30D/DE/ VQ30	1765	06803A	369	295	236	06950A	429	343	275	
Maxima	3.5L	02-06	VQ35DE	2271	06804A	480	383	307	06952A	558	444	355	
NX Coupe	2.0L	91-93	SR20DE	1544	06802	289	230	184	---	---	---	---	
Pulsar GTI-R	2.0L	90-98	SR20DET	1765	06803A	369	295	236	06950A	429	343	275	
Sentra	2.0L	91-99	SR20DE	1544	06802	289	230	184	---	---	---	---	
Silvia S13/S14	2.0L	93-99	SR20DET	1765	06803B	369	295	236	06950B	429	343	275	
Silvia S15	2.0L	3/99-00	SR20DET	1765	06803B	369	295	236	06950B	429	343	275	
Nissan Truck													
Axxess	2.4L	89-90	KA24	2017	06801A	422	335	268	06955A	496	390	312	
Frontier	2.4L	99-02	KA24DE	2017	06801B	422	335	268	06955B	496	390	312	
Pathfinder	2.4L	87-93	Z24	2017	06801A	422	335	268	06955A	496	390	312	
Pick-Up (620/720)	2.0L, 2.2L	75-83	L20B/Z20/ Z22/SD22	1798	06805A	347	276	221	06953A	403	320	256	
Pick-Up	2.0L	83-85	Z20	2017	06801A	422	335	268	06955A	469	390	312	
Pick-Up	2.4L	9/86-90	Z24L	1798	06805A	347	276	221	06953A	403	320	256	
Pick-Up	2.4L	83-92	Z24/KA24	2017	06801A	422	335	268	06955A	496	390	312	
Pick-Up	2.4L	93-98	Z24/KA24E	2017	06801A	422	335	268	06955A	496	390	312	
Oldsmobile													
Alero	2.3L/2.4L	95-99	LD2/LD9	---	04800	349	277	222	---	---	---	---	
Plymouth													
Laser	2.0L	90-4/92	4G63T	2136	05800	412	329	264	05950	479	381	305	
Laser	2.0L	5/92-94	4G63T	2136	05800	412	329	264	05950	479	381	305	
Laser	2.0L	92-4/92	4G63T	2136	05800	412	329	264	05950	479	381	305	
Laser	2.0L	5/92-94	4G63T	2136	05800	412	329	264	05950	479	381	305	
Laser	2.0L	90-94	4G63	1544	05801	283	225	180	05951	328	261	209	

STAGE 2 Thin Pad				Disc Size (mm)	Spline Teeth/ Major Dia (mm)	Light Weight Flywheel		Notes	Standard Clutch Kit Part #
Kit Part #	Clutch Torque	TQ@ Flywheel	TQ@ Wheels			Part #	Weight (lb)		
06900A	496	470	376	240	24T/25.6	---	---	Single Turbo	06032
06900A	496	470	376	240	24T/25.6	---	---	Non-Turbo	06031
06900B	496	470	376	240	24T/25.6	---	---	Non-Turbo	06045
---	---	---	---	250	24T/25.6	---	---	Twin-Turbo	06046
---	---	---	---	250	24T/25.6	NF04	19.6	Recommended for use with Exedy Solid Flywheel (NF04), will also work with OE Dual-Mass Flywheel	NSK1000
---	---	---	---	250	24T/25.6	NF04	19.6	Includes NF04 Flywheel	NSK1000FW
---	---	---	---	250	24T/25.6	NF05	19.6	Kit includes Flywheel, DOES NOT include CSC Hydraulic Slave Cylinder (BRG0163)	---
---	---	---	---	250	24T/25.6	NF05	19.6	Kit includes Flywheel, DOES NOT include CSC Hydraulic Slave Cylinder (BRG0163)	---
---	---	---	---	225	24T/25.6	---	---	---	06004
---	---	---	---	250	24T/25.6	---	---	Includes SE-R	NSK1002
---	---	---	---	240	24T/25.6	---	---	AWD, Turbo, Non US model	---
---	---	---	---	225	24T/25.6	---	---	---	06009
---	---	---	---	225	24T/25.6	---	---	Diesel	06034
---	---	---	---	240	24T/25.6	---	---	---	06044
---	---	---	---	250	24T/25.6	---	---	---	NSK1002
06902	263	209	167	215	18T/20.6	---	---	---	KNS02
---	---	---	---	240	24T/25.6	---	---	AWD, Turbo, Non US model	---
06902	263	209	167	215	18T/20.6	---	---	---	KNS02
06901B	429	390	312	240	24T/25.6	NF02	13.9	5 Speed, Turbo, Non US Model	---
06901B	429	390	312	240	24T/25.6	---	---	6 Speed, Turbo, Non US Model	---
06900A	590	470	376	240	24T/25.6	---	---	AWD	06051
06900B	590	470	376	240	24T/25.6	---	---	2WD & AWD	06059
06900A	590	470	376	240	24T/25.6	---	---	---	06006
---	---	---	---	225	24T/25.6	---	---	2WD, 4WD	06004
06900A	590	470	376	240	24T/25.6	---	---	2WD & AWD	06006
---	---	---	---	225	24T/25.6	---	---	---	06034
06900A	590	470	376	240	24T/25.6	---	---	2WD & AWD	06006
06900A	590	470	376	240	24T/25.6	---	---	2WD & AWD	KNS03
---	---	---	---	225	14T/25	---	---	---	KGM04
05900	435	347	278	225	20T/22.4	---	---	Turbo 2WD, 6 Bolt Crank	05048
05900	435	347	278	225	20T/22.4	---	---	Turbo 2WD, 7 Bolt Crank	05048
05900	435	347	278	225	20T/22.4	MF03	12.0	Turbo AWD, 6 Bolt Crank	05048
05900	435	347	278	225	20T/22.4	MF01	12.0	Turbo AWD, 7 Bolt Crank	05048
---	---	---	---	215	20T/22.4	---	---	Non-Turbo	05051

Stage 1 - Stage 2 - Flywheels

Application	Engine Size	Year	Engine Code	Clamp Load	STAGE 1				STAGE 2 Thick Pad			
					Kit Part #	Clutch Torque	TQ@ Flywheel	TQ@ Wheels	Kit Part #	Clutch Torque	TQ@ Flywheel	TQ@ Wheels
Pontiac												
G5	2.2L	07-09	---	1866	04801	364	290	232	04950	423	337	270
G5	2.4L	07-09	---	1866	04801	364	290	232	04950	423	337	270
Grand AM	2.3L/2.4L	95-99	LD2/LD9	1785	04800	349	277	222	---	---	---	---
Solstice	2.4L	06-09	---	1866	04802	364	290	232	04951	423	337	270
Sunfire	2.3L/2.4L	95-99	LD2/LD9	1785	04800	349	277	222	---	---	---	---
Vibe	1.8L	03-06	1ZZ-FE/ 2ZZ-GE	1543	16800	283	225	180	16950	328	261	209
Saab												
9-2X	2.0L	05	---	2315	15802	454	361	289	15950	527	420	336
					---	---	---	---	NEW 15950P4	527	420	336
9-2X	2.0L	05	---	2563	15802HD	502	399	319	15950HD	583	463	371
					---	---	---	---	NEW 15950HDP4	583	463	371
9-2X	2.5L	05	---	1652	15801	319	254	203	---	---	---	---
9-2X	2.5L	06	---	2383	15804	472	376	301	15952	548	437	350
Saturn												
Sky	2.4L	07	---	1866	04802	364	290	232	04951	423	337	270
Scion												
xA	1.5L	03-06	1NZ-FE	1543	16800A	283	225	180	16950	328	261	209
xB	1.5L	03-06	1NZ-FE	1543	16800A	283	225	180	16950	328	261	209
tC	2.4L	04-06	2AZ-FE	2093	16803A	431	343	275	16953A	501	399	319
FR-S	2.0L	13	D-4S	1652	NEW 15805FW	319	254	203	---	---	---	---
Subaru												
BAJA	2.5L	03-05	EJ25	1652	15801	319	254	203	---	---	---	---
BAJA	2.5L	04-05	EJ25T	2315	15802	454	361	289	15950	527	420	336
					---	---	---	---	NEW 15950P4	527	420	336
BAJA	2.5L	04-05	EJ25T	2563	15802HD	502	399	319	15950HD	583	463	371
					---	---	---	---	NEW 15950HDP4	583	463	371
BRZ	2.0L	13	FA20	1652	15805FW	319	254	203	---	---	---	---
Forester	2.5L	98-05	EJ25	1652	15801	319	254	203	---	---	---	---
Forester	2.5L	04-05	EJ25T	2315	15802	454	361	289	15950	527	420	336
					---	---	---	---	NEW 15950P4	527	420	336
Forester	2.5L	04-05	EJ25T	2563	15802HD	502	399	319	15950HD	583	463	371
					---	---	---	---	NEW 15950HDP4	583	463	371
Forester	2.5L	06-11	EJ25T	2383	15804	472	376	301	15952	548	437	350
<i>Must change flywheel to FF502 for performance clutch kit (# 15804, #15952).</i>												
Impreza	2.5L	97-11	EJ25	1652	15801	319	254	203	---	---	---	---

STAGE 2 Thin Pad				Disc Size (mm)	Spline Teeth/ Major Dia (mm)	Light Weight Flywheel		Notes	Standard Clutch Kit Part #
Kit Part #	Clutch Torque	TQ@ Flywheel	TQ@ Wheels			Part #	Weight (lb)		
---	---	---	---	225	14T/25	GF501	10.5	Natural aspirated, Does not include CSC Hydraulic slave cylinder (BRG0143)	GMK1010
---	---	---	---	225	14T/25	GF501	10.5	Natural aspirated, Does not include CSC Hydraulic slave cylinder (BRG0143)	GMK1010
---	---	---	---	225	14T/25	---	---	---	04162
---	---	---	---	225	26T/29	GF501	10.5	Natural aspirated, Does not include CSC Hydraulic slave cylinder	GMK1032
---	---	---	---	225	14T/25	---	---	---	04158
---	---	---	---	215	21T/24.1	---	---	5spd, 6spd	KTY03/ TYK1500
15900	527	420	336	230	24T/25.2	FF01	12.7	Aero, Turbo, Pull Type	KSB03
---	---	---	---	230	24T/25.2	FF01	12.7	4 Puck design disc, Aero, Turbo, Pull Type	KSB03
---	---	---	---	230	24T/25.2	FF01	12.7	Aero, Turbo, Pull Type	KSB03
---	---	---	---	230	24T/25.2	FF01	12.7	4 Puck design disc, Aero, Turbo, Pull Type	KSB03
---	---	---	---	225	24T/25.2	FF02	12.7	Linear, Non-Turbo, SOHC	KSB04
---	---	---	---	230	24T/25.2	FF502	12.7	Aero, Turbo, Push Type	FJK1001
---	---	---	---	225	26T/29	---	---	Natural aspirated, Does not include CSC Hydraulic slave cylinder	---
---	---	---	---	215	21T/24.1	---	---	---	KTY15
---	---	---	---	215	21T/24.1	---	---	---	KTY15
---	---	---	---	240	21T/29.8	---	---	---	TYK1506
---	---	---	---	225	24T/25.2	FF02	12.7	Includes FW	---
---	---	---	---	225	24T/25.2	FF02	12.7	Non-Turbo, SOHC	KSB04
15900	527	420	336	230	24T/25.2	FF01	12.7	Turbo, DOHC, Pull Type	KSB03
---	---	---	---	230	24T/25.2	FF01	12.7	4 Puck design disc, Turbo, DOHC, Pull Type	KSB03
---	---	---	---	230	24T/25.2	FF01	12.7	Turbo, DOHC, Pull Type	KSB03
---	---	---	---	230	24T/25.2	FF01	12.7	4 Puck design disc, Turbo, DOHC, Pull Type	KSB03
---	---	---	---	225	24T/25.2	FF02	12.7	Includes FW	---
---	---	---	---	225	24T/25.2	FF02	12.7	Non-Turbo, SOHC	KSB04
15900	527	420	336	230	24T/25.2	FF01	12.7	Turbo, DOHC, Pull Type	KSB03
---	---	---	---	230	24T/25.2	FF01	12.7	4 Puck design disc, Turbo, DOHC, Pull Type	KSB03
---	---	---	---	230	24T/25.2	FF01	12.7	Turbo, DOHC, Pull Type	KSB03
---	---	---	---	230	24T/25.2	FF01	12.7	4 Puck design disc, Turbo, DOHC, Pull Type	KSB03
---	---	---	---	230	24T/25.2	FF502	12.7	Turbo, Push Type, Must use FF502 Flywheel	FJK1001
---	---	---	---	225	24T/25.2	FF02	12.7	Non-Turbo, SOHC	KSB04

Stage 1 - Stage 2 - Flywheels

Application	Engine Size	Year	Engine Code	Clamp Load	STAGE 1				STAGE 2 Thick Pad			
					Kit Part #	Clutch Torque	Flywheel TQ@	TQ@ Wheels	Kit Part #	Clutch Torque	Flywheel TQ@	TQ@ Wheels
Subaru continued												
Impreza WRX	2.0L	02-05	EJ20T	2315	15802	454	361	289	15950	527	420	336
					---	---	---	---	NEW 15950P4	527	420	336
Impreza WRX	2.0L	02-05	EJ20T	2563	15802HD	502	399	319	15950HD	583	463	371
					---	---	---	---	NEW 15950HDP4	583	463	371
Impreza WRX	2.5L	06-11	EJ25T	2383	15804	472	376	301	15952	548	437	350
Impreza WRX STI	2.5L	04-11	EJ25T	2536	15803	522	415	332	15951	607	482	386
					---	---	---	---	NEW 15951P4	607	482	386
Impreza WRX STI	2.5L	04-11	EJ25T	3597	15803HD	741	590	472	15951HD	860	685	548
					---	---	---	---	NEW 15951HDP4	860	685	548
Legacy	2.2L	91-94	EJ22T	2315	15802	454	361	289	15950	527	420	336
					---	---	---	---	NEW 15950P4	527	420	336
Legacy	2.2L	91-94	EJ22T	2563	15802HD	502	399	319	15950HD	583	463	371
					---	---	---	---	NEW 15950HDP4	583	463	371
Legacy	2.5L	96-09	EJ25	1652	15801	319	254	203	---	---	---	---
Legacy GT	2.5L	05-11	EJ25T	2383	15804	472	376	301	15952	548	437	350
<i>Must change flywheel to FF502 for performance clutch kit (# 15804, #15952).</i>												
Legacy GT Spec B	2.5L	07-09	EJ25T	2536	15803	522	415	332	15951	607	482	386
					---	---	---	---	NEW 15951P4	607	482	386
Legacy GT Spec B	2.5L	07-09	EJ25T	3597	15803HD	741	590	472	15951HD	860	685	548
					---	---	---	---	NEW 15951HDP4	860	685	548
Legacy	3.0L	05	EZ30D	1652	15801	319	254	203	---	---	---	---
Toyota												
Camry	2.5L	88-91	2VZF	2093	16803A	431	343	275	16953A	501	399	319
Camry	3.0L	92-01	3VZ/1MZFE	2093	16803A	431	343	275	16953A	501	399	319
Celica	1.8L	94-00	7AFE/1ZZ-FE	1543	16800	283	225	180	16950	328	261	209
Celica	2.0L	88-89	3S-GTE	2093	16803C	431	343	275	16953C	501	399	319
Celica	2.0L	90-94	3S-GTE	2093	16803A	431	343	275	16953A	501	399	319
Celica GT-S	1.8L	00-05	1ZZ-FE/2ZZ-GE	1543	16800	283	225	180	16950	328	261	209
Corolla	1.6L	80-82	3TC	1212	16804A	212	169	133	16954A	246	196	157
Corolla	1.6L	8/83-87	4ALC	1212	16804A	212	169	133	16954A	246	196	157
Corolla	1.6L	8/83-89	4ALC	1212	16804B	212	169	133	16954B	246	196	157
Corolla GT-S	1.6L	85-87	4AGE	1212	16804A	212	169	133	16954A	246	196	157
Corolla GT-S	1.6L	88-7/89	4AGE	1212	16804B	212	169	133	16954B	246	196	157
Corolla GT-S	1.6L	8/89-92	4AGE	1543	16800	283	225	180	16950	328	261	209
Corolla	1.6L	89-4/91	4AFE	1212	16804B	212	169	133	16954B	246	196	157
Corolla	1.6L	5/91-8/92	4AFE	1212	16804C	212	169	133	16954C	246	196	157
Corolla FX	1.6L	9/86-8/88	4AGELC	1212	16804B	212	169	133	16954B	246	196	157

STAGE 2 Thin Pad				Disc Size (mm)	Spline Teeth/ Major Dia (mm)	Light Weight Flywheel		Notes	Standard Clutch Kit Part #
Kit Part #	Clutch Torque	TA@ Flywheel	TA@ Wheels			Part #	Weight (lb)		
15900	527	420	336	230	24T/25.2	FF01	12.7	Turbo, Pull Type, (GC8, GF8, GDA)	KSB03
---	---	---	---	230	24T/25.2	FF01	12.7	4 Puck design disc, Turbo, Pull Type, (GC8, GF8, GDA)	KSB03
---	---	---	---	230	24T/25.2	FF01	12.7	Turbo, Pull Type, (GC8, GF8, GDA)	KSB03
---	---	---	---	230	24T/25.2	FF01	12.7	4 Puck design disc, Turbo, Pull Type, (GC8, GF8, GDA)	KSB03
---	---	---	---	230	24T/25.2	FF502	12.7	Turbo, Push Type	FJK1001
---	---	---	---	240	24T/25.2	FF501	13.3	Turbo, Pull Type, US Model	FJK1000
---	---	---	---	240	24T/25.2	FF501	13.3	4 Puck design disc, Turbo, Pull Type, US Model	FJK1000
---	---	---	---	240	24T/25.2	FF501	13.3	Turbo, Pull Type, US Model	FJK1000
---	---	---	---	240	24T/25.2	FF501	13.3	4 Puck design disc, Turbo, Pull Type, US Model	FJK1000
15900	527	420	336	230	24T/25.2	FF01	12.7	Turbo, DOHC, Pull Type	KSB01
---	---	---	---	230	24T/25.2	FF01	12.7	4 Puck design disc, Turbo, DOHC, Pull Type	KSB01
---	---	---	---	230	24T/25.2	FF01	12.7	Turbo, DOHC, Pull Type	KSB01
---	---	---	---	230	24T/25.2	FF01	12.7	4 Puck design disc, Turbo, DOHC, Pull Type	KSB01
---	---	---	---	225	24T/25.2	FF02	12.7	Non-Turbo, SOHC	KSB04
---	---	---	---	230	24T/25.2	FF502	12.7	Turbo, Push Type, Must use FF502 Flywheel	FJK1001FW
---	---	---	---	240	24T/25.2	FF501	13.3	6 Speed Transmission, Spec B, Must use FF501	FJK1002
---	---	---	---	240	24T/25.2	FF501	13.3	4 Puck design disc, 6 Speed Transmission, Spec B, Must use FF501	FJK1002
---	---	---	---	240	24T/25.2	FF501	13.3	6 Speed Transmission, Spec B, Must use FF501	FJK1002
---	---	---	---	240	24T/25.2	FF501	13.3	4 Puck design disc, 6 Speed Transmission, Spec B, Must use FF501	FJK1002
---	---	---	---	225	24T/25.2	FF02	12.7	Non-Turbo, SOHC	KSB04
---	---	---	---	240	21T/29.8	---	---	---	16082
---	---	---	---	240	21T/29.8	---	---	---	16082
---	---	---	---	215	21T/24.1	---	---	---	KTY18
---	---	---	---	240	21T/29.8	---	---	Turbo	16062
---	---	---	---	240	21T/29.8	---	---	Turbo	KTY11
---	---	---	---	215	21T/24.1	---	---	VVLT-I	KTY14
---	---	---	---	200	21T/24.1	---	---	4 Door 4 Speed & All w/5 Speed	16070
---	---	---	---	200	21T/24.1	---	---	RWD, Except GTS	16070
---	---	---	---	200	21T/24.1	---	---	FWD, Except GTS	16042
---	---	---	---	200	21T/24.1	---	---	---	16070
---	---	---	---	200	21T/24.1	---	---	---	16070
---	---	---	---	215	21T/24.1	TF01	10.8	---	16074
---	---	---	---	200	21T/24.1	---	---	FWD, Except GTS	16070
---	---	---	---	200	21T/24.1	---	---	FWD, 2WD, Except GTS	16070
---	---	---	---	200	21T/24.1	---	---	FX16	KTY06

Stage 1 - Stage 2 - Flywheels

Application	Engine Size	Year	Engine Code	Clamp Load	STAGE 1				STAGE 2 Thick Pad				
					Kit Part #	Clutch Torque	Flywheel TQ@	TQ@ Wheels	Kit Part #	Clutch Torque	Flywheel TQ@	TQ@ Wheels	
Toyota continued													
Corolla FX	1.6L	2/87-8/88	4ALC	1212	16804B	212	169	133	16954B	246	196	157	
Corolla	1.8L	93-04	7A-FE	1543	16800	283	225	180	16950	328	261	209	
ECHO	1.5L	00-05	1NZ-FE	1543	16800A	283	225	180	16950A	328	261	209	
GT86	2.0L	13	4U-GSE	1652	NEW 15805FW	319	254	203	---	---	---	---	
Matrix	1.8L	03-07	1ZZ-FE/2ZZ-GE	1543	16800	283	225	180	16950	328	261	209	
MR-2	1.6L	85	4AGELC	1212	16804B	212	169	133	16954B	246	196	157	
MR-2	1.6L	86-89	4AGE	1543	16800	283	225	180	16950	328	261	209	
MR-2	1.6L SC	88-89	4AGZ	1549	16802	299	238	191	16952	347	277	222	
MR-2	2.0L	90-95	3S-GTE	2093	16803A	431	343	275	16953A	501	399	319	
MR-2 Spyder	1.8L	00-05	1ZZ-FE	1543	16800	283	225	180	16950	328	261	209	
Paseo	1.5L	92-99	5E-FE	1212	16804B	212	169	133	16954B	246	196	157	
Yaris	1.5L	06	1NZ-FE	1543	16800A	283	225	180	16950A	328	261	209	
Supra	2.6L	79-80	4ME	1753	16801B	339	270	216	16951B	393	313	251	
Supra	2.8L	81	5ME	1753	16801B	339	270	216	16951B	393	313	251	
Tercel	1.5L	91-94	3E-E	1212	16804B	212	169	133	16954B	246	196	157	
Tercel	1.5L	95-98	5E-FE	1212	16804B	212	169	133	16954B	246	196	157	
Toyota Truck													
4-Runner	2.4L	85-87	22REC	1753	16801B	339	270	216	16951B	393	313	251	
4-Runner	2.4L	89-92	22RE/ 22REC	1753	16801A	339	270	216	16951A	393	313	251	
4-Runner	2.4L	93-95	22RE/ 22REC	1753	16801A	339	270	216	16951A	393	313	251	
4-Runner	2.7L	96-00	3RZ-FE	1985	16806A	420	326	272	16956A	502	371	309	
4-Runner	3.0L	88-95	3VZE	1852	16803B	369	294	235	16953B	441	399	319	
4-Runner	3.4L	96-02	5VZ-FE	1985	16805	420	326	272	16955	502	371	309	
Pick-Up	2.4L	81-88	22R/ 22REC	1753	16801B	339	270	216	16951B	393	313	251	
Pick-Up	2.4L	89-92	22R/ 22RE	1753	16801A	339	270	216	16951A	393	313	251	
Pick-Up	2.4L	93-95	22R/ 22RE	1753	16801A	339	270	216	16951A	393	313	251	
T100	2.7L	94-98	3RZ-FE	1985	16806A	420	326	272	16956A	502	371	309	
T100	3.0L	93-94	3VZE	1852	16803B	369	294	235	16956B	502	371	309	
T100	3.0L	93-94	3VZE	1985	16806B	420	326	272	16956B	502	371	309	
T100	3.4L	95-98	5VZ-FE	1985	16805	420	326	272	16955	502	371	309	
Tacoma	2.4L	01-04	2RZ-FE	1985	16806A	420	326	272	16956A	502	371	309	
Tacoma	2.7L	95-04	3RZ-FE	1985	16806A	420	326	272	16956A	502	371	309	
Tacoma	3.4L	95-04	5VZ-FE	1985	16805	420	326	272	16955	502	371	309	
Tundra	3.4L	00-04	5VZ-FE	1985	16805	420	326	272	16955	502	371	309	
Volkswagen													
Corrado	2.8L	92-95	---	2091	17800	404	321	257	17950	474	377	302	
Golf/Golf III/ GTI	2.8L	95-02	AAA/ AFP	2091	17800	404	321	257	17950	474	377	302	
Jetta/ Jetta III	2.8L	94-02	AAA/ AFP	2091	17800	404	321	257	17950	474	377	302	
Passat	2.8L	93-97	AAA	2091	17800	404	321	257	17950	474	377	302	

STAGE 2 Thin Pad				Disc Size (mm)	Spline Teeth/ Major Dia (mm)	Light Weight Flywheel		Notes	Standard Clutch Kit Part #
Kit Part #	Clutch Torque	Flywheel TQ@	Wheels TQ@			Part #	Weight (lb)		
---	---	---	---	200	21T/24.1	---	---	---	16042
---	---	---	---	215	21T/24.1	---	---	---	KTY18
---	---	---	---	215	21T/24.1	---	---	---	KTY15
---	---	---	---	225	24T/25.2	FF02	12.7	Includes FW	---
---	---	---	---	215	21T/24.1	---	---	5 Speed, 6 Speed	KTY03/ TYK1500
---	---	---	---	200	21T/24.1	---	---	---	16029
---	---	---	---	215	21T/24.1	TF01	10.8	---	16074
---	---	---	---	225	21T/29.8	---	---	Supercharged	16075
---	---	---	---	240	21T/29.8	---	---	Turbo	16062
---	---	---	---	215	21T/24.1	---	---	---	KTY03
---	---	---	---	200	21T/24.1	---	---	---	16029
---	---	---	---	215	21T/24.1	---	---	---	---
---	---	---	---	225	21T/29.8	---	---	---	16016
---	---	---	---	225	21T/29.8	---	---	---	16016
---	---	---	---	200	21T/24.1	---	---	4 Speed Only	16070
---	---	---	---	200	21T/24.1	---	---	---	16070
---	---	---	---	225	21T/29.8	---	---	Non-Turbo	16057
---	---	---	---	225	21T/29.8	---	---	2WD & 4 WD	16058
---	---	---	---	225	21T/29.8	---	---	2WD	16058
---	---	---	---	250	21T/29.8	---	---	---	16090
---	---	---	---	240	21T/29.8	---	---	2WD & 4 WD	16059
---	---	---	---	250	21T/29.8	---	---	---	16087
---	---	---	---	225	21T/29.8	---	---	Non-Turbo	16057
---	---	---	---	225	21T/29.8	---	---	2WD & 4 WD	16058
---	---	---	---	225	21T/29.8	---	---	2WD	16058
---	---	---	---	250	21T/29.8	---	---	---	16090
---	---	---	---	250	21T/29.8	---	---	2WD	16059
---	---	---	---	250	21T/29.8	---	---	4WD	KTY16
---	---	---	---	250	21T/29.8	---	---	---	16087
---	---	---	---	250	21T/29.8	---	---	4WD	16090
---	---	---	---	250	21T/29.8	---	---	---	16090
---	---	---	---	250	21T/29.8	---	---	---	16087
---	---	---	---	250	21T/29.8	---	---	---	16087
---	---	---	---	228	28T/22.2	---	---	VR6, 5 Speed	17036
---	---	---	---	228	28T/22.2	---	---	VR6, 5 Speed	17036
---	---	---	---	228	28T/22.2	---	---	VR6, 5 Speed	17036
---	---	---	---	228	28T/22.2	---	---	VR6, 5 Speed	17036

Stage 3 - Stage 4 - Stage 5

Stage 3 – Single Cerametallic ■ Single Carbon ■ Stage 4 – Twin Cerametallic ■ Twin Carbon ■ Stage 5 – Triple Cerametallic ■ Triple Carbon ■

Application	Liter	Year	Engine	Clamp Load	Part #	Number of Disc	Disc Material	Sprung Center (D-core)	Clutch Torque	
Acura										
Integra	1.8L	90-91	B18A1	2023	HH06SD	SINGLE	CERA	YES	422	
					HM042SR	TWIN	CERA	NO	767	
Integra	1.7/1.8L	92-93	B17A/B18A	2203	HH02SBMC1	SINGLE	CARBON	NO	422	
					HH02SD	SINGLE	CERA	YES	422	
					HM022SR	TWIN	CERA	NO	767	
Integra	1.8L	94-01	B18B/B18C	2203	HH02SBMC1	SINGLE	CARBON	NO	422	
					HH02SD	SINGLE	CERA	YES	422	
					HM022SR	TWIN	CERA	NO	767	
NSX	3.0L	91-96	C30A1	2922	HH04SD1	SINGLE	CERA	YES	647	
					2653	HH04SDMC	SINGLE	CARBON	YES	559
					2630	HM012SBMC1	TWIN	CARBON	NO	1009
					1765	HM012SD	TWIN	CERA	YES	736
					1765	NEW HM013SB	TRIPLE	CERA	YES	1074
NSX	3.2L	97-05	C32B1	2922	HH04SD1	SINGLE	CERA	YES	647	
					2653	HH04SDMC	SINGLE	CARBON	YES	559
					2630	HM012SBMC1	TWIN	CARBON	NO	1009
					1765	HM012SD	TWIN	CERA	YES	736
					1765	NEW HM013SB	TRIPLE	CERA	YES	1074
RSX	2.0L	02-07	K20	2023	HH03SD	SINGLE	CERA	YES	422	
					2113	HH03SBMC	SINGLE	CARBON	NO	405
					2428	HM032SBL	TWIN	CERA	NO	1012
TSX	2.4L	03-08	K24	2023	HH03SD	SINGLE	CERA	YES	422	
					2113	HH03SBMC	SINGLE	CARBON	NO	405
					2428	HM032SBL	TWIN	CERA	NO	1012
BMW										
Mini Cooper-S	1.6L	01-06	W11B16	2023	BH01SD	SINGLE	CERA	YES	422	
323i, 323is, 323Ci	2.5L	98	M52	2653	BH02SD	SINGLE	CERA	YES	612	
323is, 323Ci	2.5L	99	M52	2653	BH02SD	SINGLE	CERA	YES	612	
328i, 328Ci	2.8L	96-99	M52	2653	BH02SD	SINGLE	CERA	YES	612	
Z3	2.8L	97-98	M52	2653	BH02SD	SINGLE	CERA	YES	612	
Chevrolet										
Camaro	5.7L	98-02	LS-1	3597	GH01SD1	SINGLE	CERA	YES	918	
					2428	GT04SD	TWIN	CERA	YES	1087
					2608	GM013SBMC1	TRIPLE	CARBON	NO	1346
					3035	GT04XD	TWIN	CERA	YES	1415
Camaro SS	6.2L	10	LS-3	2428	GT04SD	TWIN	CERA	YES	1087	
					3035	GT04XD	TWIN	CERA	YES	1415
					2608	GM013SBMC1	TRIPLE	CARBON	NO	1346
Cobalt SS	2.0L SC	05-07	LSJ	2653	GH02SD	SINGLE	CERA	YES	612	
	2.0L Turbo	08-09		2653	GH02SD	SINGLE	CERA	YES	612	

**** Does Not Include Bearing**

TQ Capac @Whls	Disc Size (mm)	Type (Push or Pull)	Spline Teeth/Major Dia (mm)	Flywheel to Crank Bolt ft-lb	PP Assby. to Flywheel ft-lb	Notes	Standard Clutch Kit Part #
235	200	PUSH	24T/25	77	23	Cable Clutch	08017
427	184	---	---	77	23	---	---
168	200	PUSH	24T/26	77	23	Cable Clutch	08028
235	200	---	---	77	23	---	---
427	184	---	---	77	23	---	---
168	200	PUSH	24T/26	77	23	Hydraulic Clutch	KHC05
235	200	---	---	77	23	---	---
427	184	---	---	77	23	---	---
375	225	PULL	24T/26	77	23	---	---
223	225	---	---	77	23	---	---
402	200	---	---	77	23	---	---
409	200	---	---	77	23	---	---
614	200	---	---	77	23	---	---
375	225	PULL	24T/26	77	23	Flywheel Crank bolts required Part # 90011-PR7-000 (8pcs), Input shaft must be changed on transmission to 91-96 model	---
223	225	---	---	77	23	---	---
402	200	---	---	77	23	---	---
409	200	---	---	77	23	---	---
614	200	---	---	77	23	---	---
235	200	PUSH	24T/26	91	23	5 Speed/6 Speed	KHC09/KHC10
162	200	---	---	91	23	---	---
563	200	---	---	91	23	---	---
235	200	PUSH	24T/26	91	23	6 Speed	HCK1001
162	200	---	---	91	23	---	---
563	200	---	---	91	23	---	---
235	200	PUSH	14T/25	67	23	6 Speed, Supercharged	BMK1001FW
340	225	PUSH	10T/29	78	23	E36	03011
340	225	PUSH	10T/29	78	23	E36	03011
340	225	PUSH	10T/29	78	23	E36	KBM11
340	225	PUSH	10T/29	78	23	E36/7	KBM11
506	250	PUSH	26T/29	74	23	6 Speed, Strap drive type. All others are lug drive type.	04173
604	215	---	---	74	23	---	---
690	225	---	---	74	23	---	---
847	225	---	---	74	23	---	---
604	215	PUSH	26T/29	74	23	Strap drive type. All others are lug drive type.	---
847	225	---	---	74	23	---	---
690	225	---	---	74	23	---	---
340	225	PUSH	14T/25	39 **	23	Supercharged	GMK1016
340	225	PUSH	14T/25	39 **	23	Turbo	---

Stage 3 - Stage 4 - Stage 5

Stage 3 – Single Cerametallic ■ Single Carbon ■ Stage 4 – Twin Cerametallic ■ Twin Carbon ■ Stage 5 – Triple Cerametallic ■ Triple Carbon ■

Application	Liter	Year	Engine	Clamp Load	Part #	Number of Disc	Disc Material	Sprung Center (D-core)	Clutch Torque
-------------	-------	------	--------	------------	--------	----------------	---------------	------------------------	---------------

Chevrolet continued

Corvette	5.7L/6.0L	97-08	LS-1/LS-2/LS-6	3597	GH01SD1	SINGLE	CERA	YES	918	
					2428	GT04SD	TWIN	CERA	YES	1087
					2608	GM013SBMC1	TRIPLE	CARBON	NO	1346
					3035	GT04XD	TWIN	CERA	YES	1415
Corvette	7.0L	06-10	LS-7	3035	GT04XD	TWIN	CERA	YES	1415	
					2608	GM013SBMC1	TRIPLE	CARBON	NO	1346
Corvette	6.2L	09	LS-3	2428	GT04SD	TWIN	CERA	YES	1087	
					3035	GT04XD	TWIN	CERA	YES	1415
					2608	GM013SBMC1	TRIPLE	CARBON	NO	1346

Ford

Focus	2.0L	00-03	Zetec	2653	EH01SD	SINGLE	CERA	YES	612	
			Duratec	2653	EH05SD	SINGLE	CERA	YES	612	
Mustang	4.6L	96-10	---	3597	EH02SD1	SINGLE	CERA	YES	909	
					2428	ET01SD	TWIN	CERA	YES	1087
Mustang	4.6L	96-10	---	2428	ET02SD	TWIN	CERA	YES	1087	
Mustang	4.6L	96-10	---	3597	EH04SD1	SINGLE	CERA	YES	909	
					2428	ET03SD	TWIN	CERA	YES	1087
					---	ET03XD	TWIN	CERA	YES	1317
Mustang	5.0L	11	---	2922	ET04XD	TWIN	CERA	YES	1317	
Mustang	5.4L	07-11	---	---	ET03XD	TWIN	CERA	YES	1317	

Honda

Accord	2.2L	94-97	H22A	2023	HH05SD	SINGLE	CERA	YES	422	
Civic SI	1.6L	99-00	B16A	2203	HH02SBMC1	SINGLE	CARBON	NO	422	
					2023	HH02SD	SINGLE	CERA	YES	422
					2023	HM022SR	TWIN	CERA	NO	767
Civic SI	2.0L	02-08	K20	2023	HH03SD	SINGLE	CERA	YES	422	
					2113	HH03SBMC	SINGLE	CARBON	NO	405
					2428	HM032SBL	TWIN	CERA	NO	1012
Del Sol	1.6L	94-97	B16A	2113	HH02SBMC	SINGLE	CARBON	NO	405	
					2023	HH02SD	SINGLE	CERA	YES	422
					2023	HM022SR	TWIN	CERA	NO	767
S2000	2.0L/2.2L	00-08	F20C/F22C	2203	HH01SD	SINGLE	CERA	YES	459	
					2540	HH01SDMC1	SINGLE	CARBON	YES	563
					2428	HM052SBMC	TWIN	CARBON	NO	1024
					2338	HM052SR	TWIN	CERA	NO	974
Prelude	2.2L	94-97	H22A	2023	HH05SD	SINGLE	CERA	YES	422	

Hyundai

Genesis	2.0L	10-11		2428	RM012SD	TWIN	CERA	YES	1012
---------	------	-------	--	------	---------	------	------	-----	------

** Does Not Include Bearing

TQ Capac @Whls	Disc Size (mm)	Type (Push or Pull)	Spline Teeth/Major Dia (mm)	Flywheel to Crank Bolt ft-lb	PP Assby. to Flywheel ft-lb	Notes	Standard Clutch Kit Part #
506	250	PUSH	26T/29	74	23	6 Speed, Strap drive type. All others are lug drive type.	04173
604	215	---	---	74	23	C5	---
690	225	---	---	74	23	---	---
847	225	---	---	74	23	---	---
847	225	PUSH	26T/29	74	23	Z06,C6 , 6 Speed, Strap drive type. All others are lug drive type.	---
690	225	---	---	74	23	---	---
604	215	PUSH	26T/29	74	23	C6 , 6 Speed, Strap drive type. All others are lug drive type.	---
847	225	---	---	74	23	---	---
690	225	---	---	74	23	---	---
340	225	PUSH	23T/25	61	23	DOHC, 5 Speed, Not SVT	KFM01
340	225	---	---	---	---	---	FMK1009
506	250	PUSH	10T/27.5	59	23	8 Bolt Crank, SOHC/DOHC, Strap drive type. All others are lug drive type.	KFM08HP
604	215	---	---	59	23	---	---
604	215	PUSH	10T/27.5	59	23	6 Bolt Crank, SOHC, Strap drive type. All others are lug drive type.	KFM08HP
506	250	PUSH	26T/29	59	23	8 Bolt Crank, TREMAC TRANS, Strap drive type. All others are lug drive type.	---
604	215	---	---	59	23	---	---
847	225	---	---	59	23	---	---
847	225	PUSH	23T/26.2	---	---	---	---
847	225	PUSH	26T/29	59	23	Shelby GT500/GT500KR, 8 Bolt crank	---
235	200	PUSH	24T/26	---	---	---	KHC03
168	200	PUSH	24T/26	77	23	---	KHC05
235	200	---	---	77	23	---	---
427	184	---	---	77	23	---	---
235	200	PUSH	24T/26	91	23	---	KHC09
162	200	---	---	91	23	---	---
563	200	---	---	91	23	---	---
162	200	PUSH	24T/26	77	23	---	KHC06
235	200	---	---	77	23	---	---
427	184	---	---	77	23	---	---
255	200	PULL	24T/26	95	23	AP-1	KHC06
213	200	---	---	95	23	---	---
371	200	---	---	95	23	---	---
542	200	---	---	95	23	---	---
235	200	PUSH	24T/26	---	---	---	KHC03
563	200	PUSH	23T/26.2	---	---	Turbo	---

Stage 3 - Stage 4 - Stage 5

Stage 3 – Single Cerametallic ■ Single Carbon ■ Stage 4 – Twin Cerametallic ■ Twin Carbon ■ Stage 5 – Triple Cerametallic ■ Triple Carbon ■

Application	Liter	Year	Engine	Clamp Load	Part #	Number of Disc	Disc Material	Sprung Center (D-core)	Clutch Torque	
Infiniti										
G35	3.5L	03-07	VQ35DE	2630	NM072SBMC1	TWIN	CARBON	NO	1009	
					2653	NM072SDMC1	TWIN	CARBON	YES	1150
					2653	NM072HD	TWIN	CERA	YES	1106
					3035	NT01HDMC	TWIN	CARBON	YES	1315
					3709	NMA73HBMC1	TRIPLE	CARBON	NO	2411
Mazda										
MX-5 Miata	1.6L/1.8L	90-05	B6/BP-ZE	2113	ZH03SBMC	SINGLE	CARBON	NO	405	
					---	ZH03SDMC1	SINGLE	CARBON	YES	405
RX-7	1.3L	86-91	13B-RE	2653	ZH02SBMC	SINGLE	CARBON	NO	508	
					2653	ZH02SD	SINGLE	CERA	YES	562
					2023	ZH02SDMC	SINGLE	CARBON	YES	387
					2428	ZM012SBMC	TWIN	CARBON	NO	930
					2205	ZM012SD	TWIN	CERA	YES	919
					2205	ZM013SR	TRIPLE	CERA	NO	1378
RX-7	1.3L	93-95	13B-REW	2922	ZH01SD1	SINGLE	CERA	YES	674	
					2630	ZM022SBMC1	TWIN	CARBON	NO	1009
					2205	ZM022SD	TWIN	CERA	YES	919
					2653	ZM022SDMC1	TWIN	CARBON	YES	1150
					2428	ZM023SBMC	TRIPLE	CARBON	NO	1394
					2205	ZM023SR	TRIPLE	CERA	NO	1378
RX-8	1.3L	03-07	13B-MSP	2653	ZH02SBMC	SINGLE	CARBON	NO	508	
					2653	ZH02SD	SINGLE	CERA	YES	562
					2023	ZH02SDMC	SINGLE	CARBON	YES	387
					2428	ZM012SBMC	TWIN	CARBON	NO	930
					2205	ZM012SD	TWIN	CERA	YES	919
					2205	ZM013SR	TRIPLE	CERA	NO	1378
Mitsubishi										
Lancer Evo 4/5/6/7	2.0L	8/96-02	4G63T	2922	MM022HBMC	TWIN	CARBON	NO	1121	
					2653	MM022HD	TWIN	CERA	YES	1106
					2205	MM022SD	TWIN	CERA	YES	919
					2653	MM022SDMC1	TWIN	CARBON	YES	1150
					3170	MM023HBMC1	TRIPLE	CARBON	NO	1824
					2653	MM023HR	TRIPLE	CERA	NO	1659
					2205	MM023SR	TRIPLE	CERA	NO	1378
Lancer Evo 8/MR/9	2.0L	03-07	4G63T	2922	MM022HBMC	TWIN	CARBON	NO	1121	
					2653	MM022HD	TWIN	CERA	YES	1106
					2205	MM022SD	TWIN	CERA	YES	919
					2653	MM022SDMC1	TWIN	CARBON	YES	1150
					3170	MM023HBMC1	TRIPLE	CARBON	NO	1824
					2653	MM023HR	TRIPLE	CERA	NO	1659
					2205	MM023SR	TRIPLE	CERA	NO	1378

**** Does Not Include Bearing**

TQ Capac @Whls	Disc Size (mm)	Type (Push or Pull)	Spline Teeth/Major Dia (mm)	Flywheel to Crank Bolt ft-lb	PP Assby. to Flywheel ft-lb	Notes	Standard Clutch Kit Part #
402	200	PUSH	24T/25.6	66	23	8 flywheel crank bolts required part Number #12315-30P01	NSK1000
458	225	---	---	66	23	---	---
615	200	PUSH	24T/25.6	66	23	---	---
516	225	---	---	66	23	High clamp load and strap plate driven for high torque and eliminate rattling noise at shifting.	---
981	225	---	---	66	23	---	---
162	200	PUSH	22T/24.3	75	23	---	---
162	200	---	---	75	23	---	---
223	200	PUSH	23T/26.2	48	23	Turbo, FC3S, Includes Flywheel Bolts	10037
340	225	---	---	48	23	Need adapter/counterweight N327-11-521A (Built prior to 1/1989)	---
159	200	---	---	48	23	Need adapter/counterweight N351-11-521 (Built after 1/1989)	---
373	200	---	---	48	23	---	---
511	200	---	---	48	23	---	---
767	200	---	---	48	23	---	---
375	225	PULL	23T/26.4	48	23	Turbo, FC3S, Includes Flywheel Bolts	KMZ01
402	200	---	---	48	23	Need adapter/counterweight N351-11-521.	---
511	200	---	---	48	23	---	---
458	225	---	---	48	23	---	---
568	200	---	---	48	23	---	---
767	200	---	---	48	23	---	---
223	200	PUSH	23T/26.2	48	23	---	MZK1002
340	225	---	---	48	23	Need adapter/counterweight N322-11-52X.	---
159	200	---	---	48	23	---	---
373	200	---	---	48	23	---	---
511	200	---	---	48	23	---	---
767	200	---	---	48	23	---	---
447	200	PULL	23T/26.2	99	23	Model not sold in the USA	MBK1002
615	200	---	---	99	23	---	---
511	200	---	---	99	23	---	---
458	225	---	---	99	23	---	---
742	200	---	---	99	23	---	---
923	200	---	---	99	23	---	---
767	200	---	---	99	23	---	---
447	200	PULL	23T/26.2	99	23	5 Speed & 6 Speed	MBK1001
615	200	---	---	99	23	---	---
511	200	---	---	99	23	---	---
458	225	---	---	99	23	---	---
742	200	---	---	99	23	---	---
923	200	---	---	99	23	---	---
767	200	---	---	99	23	---	---

Stage 3 - Stage 4 - Stage 5

Stage 3 – Single Cerametallic ■ Single Carbon ■ Stage 4 – Twin Cerametallic ■ Twin Carbon ■ Stage 5 – Triple Cerametallic ■ Triple Carbon ■

Application	Liter	Year	Engine	Clamp Load	Part #	Number of Disc	Disc Material	Sprung Center (D-core)	Clutch Torque	
Mitsubishi continued										
Lancer Evo 10	2.0L	08-Up	4B11	2205	MM062SD	TWIN	CERA	YES	919	
					2653	MM062HD	TWIN	CERA	YES	1106
					2428	MM062SBL	TWIN	CERA	NO	---
					2653	MM062SDMC1	TWIN	CARBON	YES	1150
					2205	MM063SB	TRIPLE	CERA	YES	1378
					2653	MM063HB	TRIPLE	CERA	YES	1659
Nissan										
240SX	2.4L	89-98	KA24E/ DE	2922	NH08SD	SINGLE	CERA	YES	674	
					2653	NM092HD	TWIN	CERA	YES	1106
					2653	NM093HB	TRIPLE	CERA	YES	1659
300 ZX	3.0L	90-96	VG30DETT	2428	NM062SBMC	TWIN	CARBON	NO	931	
					2205	NM062SD	TWIN	CERA	YES	919
					2428	NM063SBMC	TRIPLE	CARBON	NO	---
					2205	NM063SR	TRIPLE	CERA	NO	1378
350Z	3.5L	03-06	VQ35DE	2630	NM072SBMC1	TWIN	CARBON	NO	1009	
					2653	NM072SDMC1	TWIN	CARBON	YES	1150
					2653	NM072HD	TWIN	CERA	YES	1106
					3035	NT01HDMC	TWIN	CARBON	YES	1315
					3709	NMA73HBMC1	TRIPLE	CARBON	NO	2411
GTR R32 (early)	2.6L	8/89-2/93	RB26DETT	2922	NH03SD1	SINGLE	CERA	YES	674	
					2428	NM032SBMC	TWIN	CARBON	NO	931
					2205	NM032SD	TWIN	CERA	YES	919
					2653	NM032SDMC1	TWIN	CARBON	YES	1150
					2653	NM033HRW	TRIPLE	CERA	NO	1659
					2653	NM033HRWH	TRIPLE	CERA	NO	1659
					2653	NM033HRWT	TRIPLE	CERA	NO	1659
					2428	NM033SBMC	TRIPLE	CARBON	NO	1397
GTR R32 (late), R33	2.6L	2/93-98	RB26DETT	2428	NM042SBMC	TWIN	CARBON	NO	931	
					2205	NM042SD	TWIN	CERA	YES	919
					2653	NM042SDMC1	TWIN	CARBON	YES	1150
					2630	NM043SBMC1	TRIPLE	CARBON	NO	1513
					2205	NM043SR	TRIPLE	CERA	NO	1378

**** Does Not Include Bearing**

TQ Capac @Whls	Disc Size (mm)	Type (Push or Pull)	Spline Teeth/Major Dia (mm)	Flywheel to Crank Bolt ft-lb	PP Assby. to Flywheel ft-lb	Notes	Standard Clutch Kit Part #
511	200	PULL	23T/26.2	---	23	---	MBK1009
615	200	PULL	---	---	23	---	---
563	200	PULL	---	---	23	---	---
458	225	PULL	---	---	23	---	---
767	200	PULL	---	---	23	---	---
923	200	PULL	---	---	23	---	---
375	225	PUSH	24T/25.6	112	23	---	06009/ 06054
615	200	---	---	112	23	---	---
923	225	---	---	112	23	---	---
371	200	PUSH	24T/25.6	66	23	Twin Turbo	06046
511	200	---	---	66	23	---	---
568	200	---	---	66	23	---	---
767	200	---	---	66	23	---	---
402	200	PUSH	24T/25.6	66	23	8 flywheel crank bolts required part Number #12315-30P01	NSK1000
458	225	---	---	66	23	---	---
615	200	PUSH	24T/25.6	66	23	---	---
516	225	---	---	66	23	High clamp load and strap plate driven for high torque and eliminate rattling noise at shifting.	---
981	225	---	---	66	23	---	---
375	225	PUSH	24T/25.6	110	23	---	---
371	200	---	---	110	23	Requires changing the release bearing to part no. 30502-14601 (BRG002), BRG002: 45mm contact diameter, to improve pedal effort than stock bearing 62mm diameter., Model not sold in the USA, Includes Flywheel Bolts	---
511	200	---	---	110	23	---	---
458	225	---	---	110	23	---	---
923	200	PUSH	24T/25.6	110	23	Recommended for Drag, Requires changing the release bearing to part no. 30502-14601 (BRG002), BRG002: 45mm contact diameter, to improve pedal effort than stock bearing 62mm diameter., Model not sold in the USA, Includes Flywheel Bolts	---
923	200	PUSH	26T/29.4	110	23	Recommended for Drag, Requires changing the release bearing to part no. 30502-14601 (BRG002), BRG002: 45mm contact diameter, to improve pedal effort than stock bearing 62mm diameter., Model not sold in the USA, Includes Flywheel Bolts, Set up for HKS transmission	---
923	200	PUSH	21T/29.8	110	23	Recommended for Drag, Requires changing the release bearing to part no. 30502-14601 (BRG002), BRG002: 45mm contact diameter, to improve pedal effort than stock bearing 62mm diameter., Model not sold in the USA, Includes Flywheel Bolts, Set up for Trust transmission	---
568	200	---	---	110	23	---	---
371	200	PULL	24T/25.6	110	23	Model not sold in the USA, Includes Flywheel bolts	---
511	200	---	---	110	23	---	---
458	225	---	---	110	23	---	---
616	200	---	---	110	23	---	---
767	200	---	---	110	23	---	---

Stage 3 - Stage 4 - Stage 5

Stage 3 – Single Cerametallic ■ Single Carbon ■ Stage 4 – Twin Cerametallic ■ Twin Carbon ■ Stage 5 – Triple Cerametallic ■ Triple Carbon ■

Application	Liter	Year	Engine	Clamp Load	Part #	Number of Disc	Disc Material	Sprung Center (D-core)	Clutch Torque	
Nissan continued										
GTR R34	2.6L	99-02	RB26DETT	2428	NM052SBMC	TWIN	CARBON	NO	931	
					2205	NM052SD	TWIN	CERA	YES	919
					2653	NM052SDMC1	TWIN	CARBON	YES	1150
					2428	NM053SBMC	TRIPLE	CARBON	NO	1397
					2205	NM053SR	TRIPLE	CERA	NO	1378
Skyline R32/R33	2.0L/2.5L	5/89-98	RB20, 25DET	2428	NM032SBMC	TWIN	CARBON	NO	931	
					2205	NM032SD	TWIN	CERA	YES	919
					2653	NM032SDMC1	TWIN	CARBON	YES	1150
					2653	NM033HRW	TRIPLE	CERA	NO	1659
					2653	NM033HRWH	TRIPLE	CERA	NO	1659
					2653	NM033HRWT	TRIPLE	CERA	NO	1659
					2428	NM033SBMC	TRIPLE	CARBON	NO	1397
Skyline R34	2.5L	5/99-00	RB25DET	2428	NM042SBMC	TWIN	CARBON	NO	931	
					2205	NM042SD	TWIN	CERA	YES	919
					2653	NM042SDMC1	TWIN	CARBON	YES	1150
					2630	NM043SBMC1	TRIPLE	CARBON	NO	1513
					2205	NM043SR	TRIPLE	CERA	NO	1378
Silvia S13/S14	2.0L	93-99	SR20DET	2922	NH01SBMC1	SINGLE	CARBON	NO	633	
					2922	NH01SD1	SINGLE	CERA	YES	674
					2428	NM012SBMC	TWIN	CARBON	NO	931
					2205	NM012SD	TWIN	CERA	YES	919
					2428	NM013SBMC	TRIPLE	CARBON	NO	1397
					2653	NM013HB	TRIPLE	CERA	NO	1659
Silvia S15	2.0L	3/99-00	SR20DET	2653	NH02SBMC1	SINGLE	CARBON	NO	575	
					2922	NH02SD1	SINGLE	CERA	YES	674
					2922	NH02SDMC1	SINGLE	CARBON	YES	
					2428	NM022SBMC	TWIN	CARBON	NO	931
					2205	NM022SD	TWIN	CERA	YES	919

**** Does Not Include Bearing**

TQ Capac @Whls	Disc Size (mm)	Type (Push or Pull)	Spline Teeth/Major Dia (mm)	Flywheel to Crank Bolt ft-lb	PP Assby. to Flywheel ft-lb	Notes	Standard Clutch Kit Part #
371	200	PULL	24T/25.6	110	23	Model not sold in the USA, Includes Flywheel bolts	---
511	200	---	---	110	23	---	---
458	225	---	---	110	23	---	---
568	200	---	---	110	23	---	---
767	200	---	---	110	23	---	---
371	200	PUSH	24T/25.6	110	23	Non-GTR, 225mm, Requires changing the release bearing to part no. 30502-14601 (BRG002), BRG002: 45mm contact diameter, to improve pedal effort than stock bearing 62mm diameter., Model not sold in the USA, Includes Flywheel Bolts	---
511	200	---	---	110	23	---	---
458	225	---	---	110	23	---	---
923	200	PUSH	24T/25.6	110	23	Recommended for Drag, Requires changing the release bearing to part no. 30502-14601 (BRG002), BRG002: 45mm contact diameter, to improve pedal effort than stock bearing 62mm diameter., Model not sold in the USA, Includes Flywheel Bolts	---
923	200	PUSH	26T/29.4	110	23	Recommended for Drag, Requires changing the release bearing to part no. 30502-14601 (BRG002), BRG002: 45mm contact diameter, to improve pedal effort than stock bearing 62mm diameter., Model not sold in the USA, Includes Flywheel Bolts, Set up for HKS transmission	---
923	200	PUSH	21T/29.8	110	23	Recommended for Drag, Requires changing the release bearing to part no. 30502-14601 (BRG002), BRG002: 45mm contact diameter, to improve pedal effort than stock bearing 62mm diameter., Model not sold in the USA, Includes Flywheel Bolts, Set up for Trust transmission	---
568	200	---	---	110	23	---	---
371	200	PULL	24T/25.6	110	23	Non-GTR, Pull Type Clutch, Model not sold in the USA, Includes Flywheel bolts	---
511	200	---	---	110	23	---	---
458	225	---	---	110	23	---	---
616	200	---	---	110	23	---	---
767	200	---	---	110	23	---	---
246	225	PUSH	24T/25.6	66	23	5 Speed, Turbo, Requires changing the release bearing to part no. 30502-14601 (BRG002), BRG002: 45mm contact diameter, to improve pedal effort than stock bearing 62mm diameter., Model not sold in the USA, Includes Flywheel Bolts	---
375	225	---	---	66	23	---	---
371	200	---	---	66	23	---	---
511	200	---	---	66	23	---	---
568	200	---	---	66	23	---	---
923	200	---	---	---	---	---	---
223	225	PUSH	24T/25.6	66	23	6 Speed, Turbo, Requires changing the release bearing to part no. 30502-14601 (BRG002), BRG002: 45mm contact diameter, to improve pedal effort than stock bearing 62mm diameter., Model not sold in the USA, Includes Flywheel Bolts	---
375	225	---	---	66	23	---	---
246	225	---	---	66	23	---	---
371	200	---	---	66	23	---	---
511	200	---	---	66	23	---	---

Stage 3 - Stage 4 - Stage 5

Stage 3 – Single Cerametallic ■ Single Carbon ■ Stage 4 – Twin Cerametallic ■ Twin Carbon ■ Stage 5 – Triple Cerametallic ■ Triple Carbon ■

Application	Liter	Year	Engine	Clamp Load	Part #	Number of Disc	Disc Material	Sprung Center (D-core)	Clutch Torque
-------------	-------	------	--------	------------	--------	----------------	---------------	------------------------	---------------

Pontiac

Firebird	5.7L	98-02	LS-1	3597	GH01SD1	SINGLE	CERA	YES	918
				2428	GT04SD	TWIN	CERA	YES	1087
				3035	GT04XD	TWIN	CERA	YES	1415
				2608	GM013SBMC1	TRIPLE	CARBON	NO	1346
GTO	5.7L/6.0L	04-06	LS-1/LS-2	3597	GH01SD1	SINGLE	CERA	YES	918
				2428	GT04SD	TWIN	CERA	YES	1087
				3035	GT04XD	TWIN	CERA	YES	1415
				2608	GM013SBMC1	TRIPLE	CARBON	NO	1346
G8	6.0L	08-09	---	2428	GT04SD	TWIN	CERA	YES	1087
				3035	GT04XD	TWIN	CERA	YES	1415
				2608	GM013SBMC1	TRIPLE	CARBON	NO	1346

Porsche

911	---	---	---	---	PM012SDMC1	TWIN	CARBON	YES	---
				2518	PM013SBMC1	TRIPLE	CARBON	NO	1637

Saab

9-2X	2.0L	05	---	2922	FH01SD1	SINGLE	CERA	YES	689
				2630	FM012SBMC1	TWIN	CARBON	NO	1009
				2205	FM012SD	TWIN	CERA	YES	919
				2653	FM012SDMC1	TWIN	CARBON	YES	1150
	2.5L	06	---	2428	FM032SD	TWIN	CERA	YES	1012

Saturn

Ion Redline	2.0L SC	04-07	LSJ	2653	GH02SD	SINGLE	CERA	YES	612
-------------	---------	-------	-----	------	--------	--------	------	-----	-----

Scion

xA	1.5L	03-06	1NZ-FE	2113	TH06SBMC	SINGLE	CARBON	YES	405
				2023	TH06SD	SINGLE	CERA	YES	422
xB	1.5L	03-06	1NZ-FE	2113	TH06SBMC	SINGLE	CARBON	YES	405
				2023	TH06SD	SINGLE	CERA	YES	422
FR-S	2.0L	13	D-4S	2922	NEW TBA	SINGLE	CERA	YES	626
				2653	NEW TBA	TWIN	CERA	YES	1106
				2653	NEW TBA	TRIPLE	CERA	YES	1659
Tc	2.4L	04-08	2AZ-FE	2205	TM012SR	TWIN	CERA	NO	919

** Does Not Include Bearing

TQ Capac @Whls	Disc Size (mm)	Type (Push or Pull)	Spline Teeth/Major Dia (mm)	Flywheel to Crank Bolt ft-lb	PP Assby. to Flywheel ft-lb	Notes	Standard Clutch Kit Part #
506	250	PUSH	26T/29	74	23	Push Type, 6 Speed, Strap drive type. All others are lug drive type.	04173
604	215	---	---	74	23	---	---
847	225	---	---	74	23	---	---
690	225	---	---	74	23	---	---
506	250	PUSH	26T/29	74	23	Push Type, 6 Speed, Strap drive type. All others are lug drive type.	04173
604	215	---	---	74	23	---	---
847	225	---	---	74	23	---	---
690	225	---	---	74	23	---	---
604	215	PUSH	26T/29	74	23	---	---
847	225	---	---	74	23	---	---
690	225	---	---	74	23	---	---
475	225	PULL	23T/26.2	---	---	964,993,996(GT3 only), Additional OE items required (Release Bearing: 944 116 080 01, Guide Tube: 950 116 813 30, Crank Bolts: 928 102 151 01, Pilot Bearing: 931 102 111 00)	---
666	225	PULL	23T/26.2	---	---	993,996, Turbo, Additional OE items required (Release Bearing: 944 116 080 01, Guide Tube: 950 116 813 30, Crank Bolts: 928 102 151 01, Pilot Bearing: 931 102 111 00)	---
375	225	PULL	24T/25.2	55	23	Aero, Turbo, Pull Type	KSB03
402	200	---	---	55	23	---	---
511	200	---	---	55	23	---	---
458	225	---	---	55	23	---	---
563	200	PUSH	24T/25.2	55	23	Turbo, Push Type	FJK1001
340	225	PUSH	14T/25	39 **	23	Supercharged	GMK1016
162	200	PUSH	21T/24.1	66	23	---	KTY15
235	200	---	---	66	23	---	---
162	200	PUSH	21T/24.1	66	23	---	KTY15
235	200	---	---	66	23	---	---
340	225	PUSH	24T/25.2	80	23	---	---
615	200	---	---	55	23	---	---
923	200	---	---	---	---	---	---
511	200	PUSH	21T/29.8	80	23	---	TYK1505

Stage 3 - Stage 4 - Stage 5

Stage 3 – Single Cerametallic ■ Single Carbon ■ Stage 4 – Twin Cerametallic ■ Twin Carbon ■ Stage 5 – Triple Cerametallic ■ Triple Carbon ■

Application	Liter	Year	Engine	Clamp Load	Part #	Number of Disc	Disc Material	Sprung Center (D-core)	Clutch Torque	
Subaru										
BAJA	2.5L	04-05	EJ25T	2922	FH01SD1	SINGLE	CERA	YES	689	
					2630	FM012SBMC1	TWIN	CARBON	NO	1009
					2205	FM012SD	TWIN	CERA	YES	919
						FM012SDMC1	TWIN	CARBON	YES	1150
BRZ	2.0L	13	FA20	2922	NEW TBA	SINGLE	CERA	YES	626	
					2653	NEW TBA	TWIN	CERA	YES	1106
					2653	NEW TBA	TRIPLE	CERA	YES	1659
Forester	2.5L	04-05	EJ25T	2922	FH01SD1	SINGLE	CERA	YES	689	
					2630	FM012SBMC1	TWIN	CARBON	NO	1009
					2205	FM012SD	TWIN	CERA	YES	919
					2653	FM012SDMC1	TWIN	CARBON	YES	1150
Impreza WRX	2.0L	02-05	EJ20T	2922	FH01SD1	SINGLE	CERA	YES	689	
					2630	FM012SBMC1	TWIN	CARBON	NO	1009
					2205	FM012SD	TWIN	CERA	YES	919
					2653	FM012SDMC1	TWIN	CARBON	YES	1150
					2630	FM013SBMC1	TRIPLE	CARBON	YES	1513
					2653	FM013HB	TRIPLE	CERA	YES	1659
	2.5L	06-11	EJ20T	2428	FM032SD	TWIN	CERA	YES	1012	
Impreza WRX STI	2.5L	04-10	EJ25T	2922	FH02SD1	SINGLE	CERA	YES	689	
					2630	FM022SBMC1	TWIN	CARBON	NO	1009
					2203	FM022SD	TWIN	CERA	YES	919
					2653	FM022HD	TWIN	CERA	YES	1106
					2653	FM022SDMC1	TWIN	CARBON	YES	1150
					2203	FM023SB	TRIPLE	CERA	NO	1378
					2630	FM023SBMC1	TRIPLE	CARBON	NO	1513
Legacy GT	2.5L		EJ25T	2428	FM032SD	TWIN	CERA	YES	1012	
Legacy GT Spec B	2.5L	07-09	EJ25T	2922	FH02SD1	SINGLE	CERA	YES	689	
					2630	FM022SBMC1	TWIN	CARBON	NO	1009
					2203	FM022SD	TWIN	CERA	YES	919
					2653	FM022HD	TWIN	CERA	YES	1106
					2653	FM022SDMC1	TWIN	CARBON	YES	1150
					2203	FM023SB	TRIPLE	CERA	NO	1378
					2630	FM023SBMC1	TRIPLE	CARBON	NO	1513

**** Does Not Include Bearing**

TQ Capac @Whls	Disc Size (mm)	Type (Push or Pull)	Spline Teeth/Major Dia (mm)	Flywheel to Crank Bolt ft-lb	PP Assby. to Flywheel ft-lb	Notes	Standard Clutch Kit Part #
375	225	PULL	24T/25.2	55	23	Turbo, Includes Flywheel bolts	KSB03
402	200	---	---	55	23	---	---
511	200	---	---	55	23	---	---
458	225	---	---	55	23	---	---
340	225	PUSH	24T/25.2	23	---	---	---
615	200	---	---	---	---	---	---
923	200	---	---	---	---	---	---
375	225	PULL	24T/25.2	55	23	Turbo, Includes Flywheel bolts	KSB03
402	200	---	---	55	23	---	---
511	200	---	---	55	23	---	---
458	225	---	---	55	23	---	---
375	225	PULL	24T/25.2	55	23	Turbo, (GC8, GF8, GDA), Includes Flywheel bolts	KSB03
402	200	---	---	55	23	---	---
511	200	---	---	55	23	---	---
458	225	---	---	55	23	---	---
616	200	---	---	55	23	---	---
923	200	---	---	55	23	---	---
563	200	PUSH	24T/25.2	55	23	---	---
375	225	PULL	24T/25.2	55	23	Turbo, Also fits JDM (and European) STI 2.0L Turbo (GDB 6spd), Includes Flywheel bolts	FJK1000
402	200	---	---	55	23	---	---
511	200	---	---	55	23	---	---
615	200	---	---	55	23	---	---
458	225	---	---	55	23	---	---
766	200	---	---	55	23	---	---
616	200	---	---	55	23	---	---
563	200	PUSH	24T/25.2	55	23	---	FJK1001FW
375	225	PULL	24T/25.2	55	23	Turbo, 6spd, Includes Flywheel bolts	FJK1002
402	200	---	---	55	23	---	---
511	200	---	---	55	23	---	---
615	200	---	---	55	23	---	---
458	225	---	---	55	23	---	---
766	200	---	---	55	23	---	---
616	200	---	---	55	23	---	---

Stage 3 - Stage 4 - Stage 5

Stage 3 – Single Cerametallic ■ Single Carbon ■ Stage 4 – Twin Cerametallic ■ Twin Carbon ■ Stage 5 – Triple Cerametallic ■ Triple Carbon ■

Application	Liter	Year	Engine	Clamp Load	Part #	Number of Disc	Disc Material	Sprung Center (D-core)	Clutch Torque		
Toyota											
Celica	2.0L	90-94	3S-GTE	2653	TH02SBMC	SINGLE	CARBON	NO	559		
					2653	TH02SD	SINGLE	CERA	YES	612	
					2205	TM012SR	TWIN	CERA	NO	919	
Corolla	1.6L	85-89	4A-GE	2023	TH01SD	SINGLE	CERA	YES	422		
ECHO	1.5L	00-05	1NZ-FE	2023	TH06SD	SINGLE	CERA	YES	422		
GT86	2.0L	13	4U-GSE	2922	TBA	SINGLE	CERA	YES	626		
					2653	TBA	TWIN	CERA	YES	1106	
					2653	TBA	TRIPLE	CERA	YES	1659	
MR-2	1.6L	86-89	4A-GE	2023	TH01SD	SINGLE	CERA	YES	422		
					2.0L	90-95	3S-GTE	2653	TH02SBMC	SINGLE	CARBON
						2653	TH02SD	SINGLE	CERA	YES	612
						2630	TM012SBMC1	TWIN	CARBON	NO	1009
				2205	TM012SR	TWIN	CERA	NO	919		
STARLET	1.3L		4E-FTE	2113	TH07SBMC	SINGLE	CARBON	NO	405		
Supra	3.0L	91-92	1JZ-GTE	2653	TH04SD	SINGLE	CERA	YES	612		
					2630	TM032SBMC1	TWIN	CARBON	NO	1009	
					2248	TM032SD	TWIN	CERA	YES	937	
					2653	TM032SDMC	TWIN	CARBON	NO	1150	
					2630	TM033SBMC1	TRIPLE	CARBON	NO	1513	
Supra	3.0L	93-98	2JZ-GTE	2630	TM042SBMC1	TWIN	CARBON	NO	1009		
					2248	TM042SD	TWIN	CERA	YES	937	
					2653	TM042SDMC1	TWIN	CARBON	YES	1150	
					2810	TM043HBMC	TRIPLE	CARBON	NO	1826	
					2630	TM043SBMC1	TRIPLE	CARBON	NO	1513	
				2248	TM043SR	TRIPLE	CERA	NO	1405		
Yaris	1.5L	07-08	1NZ-FE	2023	TH06SD	SINGLE	CERA	YES	422		

**** Does Not Include Bearing**

TQ Capac @Whls	Disc Size (mm)	Type (Push or Pull)	Spline Teeth/Major Dia (mm)	Flywheel to Crank Bolt ft-lb	PP Assy. to Flywheel ft-lb	Notes	Standard Clutch Kit Part #
223	225	PUSH	21T/29.8	80	23	Turbo, Includes Flywheel Bolts, Bearing, Sleeve	KTY11
340	225	---	---	80	23	---	---
511	200	---	---	80	23	---	---
235	200	PUSH	21T/24.1	55	23	AE86/AE92/AE101/AE111, GTS	16070
235	200	PUSH	21T/24.1	66	23	---	---
340	225	PUSH	24T/25.2	80	23	---	---
615	200	---	---	---	---	---	---
923	200	---	---	---	---	---	---
235	200	PUSH	21T/24.1	55	23	---	16074
223	225	PUSH	21T/29.8	80	23	Turbo, Includes Flywheel Bolts, Bearing, Sleeve	16062
340	225	---	---	80	23	---	---
402	200	---	---	80	23	---	---
511	200	---	---	80	23	---	---
162	200	PUSH	21T/24.1	66	23	Turbo	---
340	225	PULL	21T/30	36*	23	Turbo	16085
402	200	---	---	36*	23	---	---
521	200	---	---	36*	23	---	---
458	225	---	---	36*	23	---	---
616	200	---	---	36*	23	---	---
402	200	PULL	14T/32	36*	23	Turbo	16093
521	200	---	---	36*	23	8 FW crank bolts required. Part Number 90910-02103.	---
458	225	---	---	36*	23	---	---
743	225	---	---	36*	23	---	---
616	200	---	---	36*	23	---	---
782	200	---	---	36*	23	---	---
235	200	PUSH	21T/24.1	66	23	---	---

NOTES:

- 1) Requires changing the release bearing to part no. 30502-14601 (BRG002)
BRG002: 45mm contact diameter, to improve pedal effort than stock bearing 62mm diameter. May also require changing the bearing carrier. See instructions for detail.
- 2) Model not sold in the USA.
- 3) Strap drive type. All others are lug drive type.
- 4) Includes Flywheel Bolts
- 5) Includes Flywheel Bolts, Bearing, Sleeve
- 6) Set up for HKS transmission

- 7) Set up for Trust transmission
- 8) Also fits JDM (and European) STI 2.0L Turbo (GDB 6spd)
- 9) High clamp load and strap plate driven for high torque and eliminate rattling noise at shifting.
* needs additional 90 degree turn
** needs additional 25 degree turn

Hyper Single Repair Parts

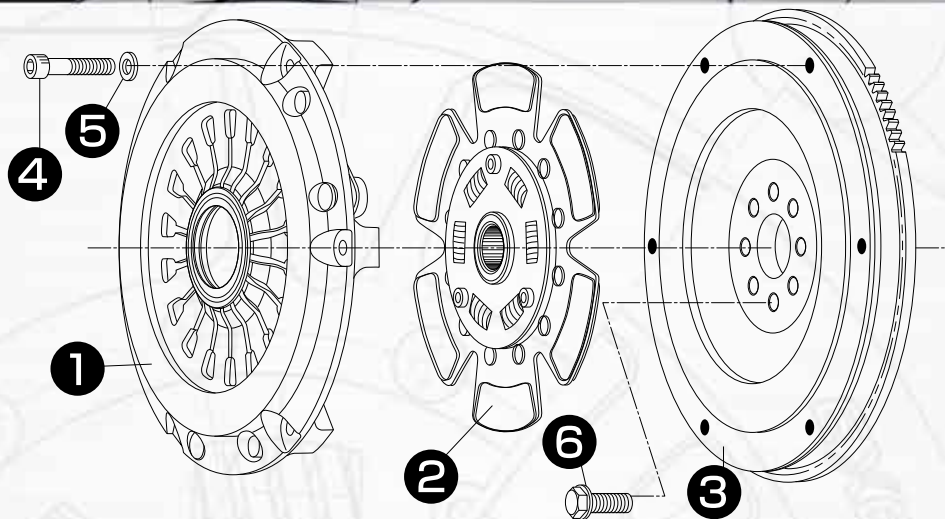

PART NO.	C.COVER Assy	CD Assy	FLYWHEEL	COVER BOLT SE	FLYWHEEL BOLT
	1	2	3	4 & 5	6
BH01SD	CH22S	DH18D	FH31	BS04	BF10
BH02SD	CH21S	DH19D	FH32	BS03	---
EH01SD	CH21S	DH01D	---	BS03	---
EH02SD1	CH14S	DH08D	FH25	BS10	---
EH03SD	CH14S	DH08D	TBA	BS10	---
EH04SD	CH14S	DH09D	FH25	BS10	---
EH05SD	CH21S	DH03D	FM100	BS03	BS50
FH01SD	CH02S	DH02D	FH02	BS03	---
FH02SD	CH02S	DH02D	FH08	BS03	---
FH02SD1	CH02S1	DH02D1	FH08	BS03	---
GH01SD	CH14S	DH09D	FH26	BS10	---
GH02SD	CH21S	DH25D	FH36	BS03	---
HH01SD	CH03S	DH04D	FH07	BS04	---
HH02SD	CH06S	DH04D	FH09	BS04	---
HH03SD	CH07S	DH04D	FH10	BS04	---
HH04SD	CH13S	DH10D	FH19	BS04	---
HH04SD1	CH13S1	DH10D1	FH19	BS04	---
HH06SD	CH06S	DH13D	FH09	BS04	---
NH01SD	CH04S	DH05D	FH05	BS03	---
NH01SD1	CH04S1	DH05D1	FH05	BS03	---
NH02SD	CH04S	DH05D	FH06	BS03	BF08
NH03SD	CH04S	DH05D	FH04	BS03	---
NH03SD1	CH04S1	DH05D1	FH04	BS03	---
NH04SD	CH02S	DH05D	FH04	BS03	---
NH08SD	CH04S	DH26D	FH37	BS03	---
TH01SD	CH08S	DH06D	FH11	BS04	---
TH02SD	CH12S	DH07D	FH15	BS03	BF04
TH03SD	CH11S	DH07D	FH14	BS03	BF09
TH04SD	CH10S	DH07D	FH13	BS03	---
TH06SD	CH07S	DH06D	FH16	BS04	---
ZH01SD	CH02S	DH03D	FH03	BS03	BF07
ZH02SD	CH05S	DH03D	FH03	BS03	BF07

Hyper Carbon Single Repair Parts

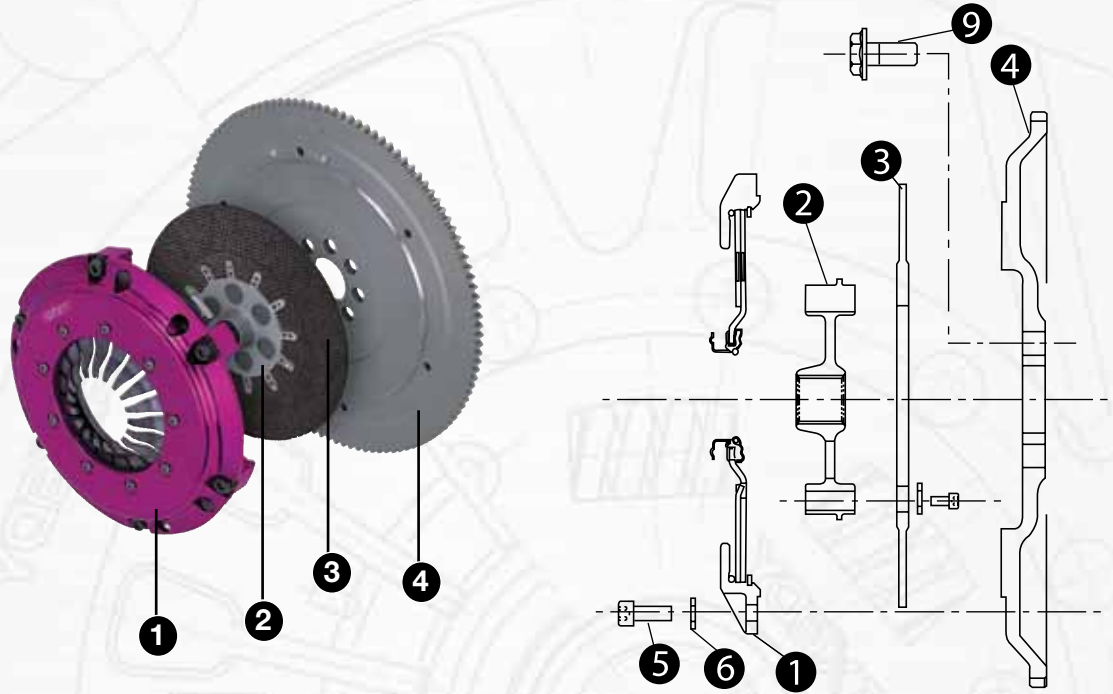

PART NO.	C. COVER ASSY	SPLINE HUB/ DISC ASSY	FLYWHEEL	BOLT SET	BOLT F/W
	1	2	4	5 & 6	9
HH01SDMC1	CH33S	DH24D	FH35	BS03	---
HH02SBMC	CH06S	SH13	FH09	BS04	---
HH03SBMC	CH07S	SH13	FH10	BS04	---
HH04SBMC	---	---	---	---	---
HH04SDMC	---	DH17D	FH35	BS03	---
HH05SBMC	CH06S	SH13	FH21	BS04	---
NH01SBMC	CH04S	SH09	FH05	BS03	---
NH02SDMC	CH25S	DH21D	FH06	BS03	BF08
TH02SBMC	CH12S	SH10	FH15	BS03	BF04
TH06SBMC	CH08S	SH18	FH16	BS04	---
TH07SBMC	CH08S	SH18	FH17	BS04	---
ZH01SBMC	CH02S	SH11	FH03	BS03	BF07
ZH02SBMC	CH05S	SH11	FH03	BS03	BF07
ZH02SDMC	---	DH14D	FH28	BS04	BF07
ZH03SBMC	CH08S	SH20	FH24	BS04	---
ZH03SDMC	CH18S	DH15D	FH29	BS04	---

Hyper Multi-Plate Repair Parts

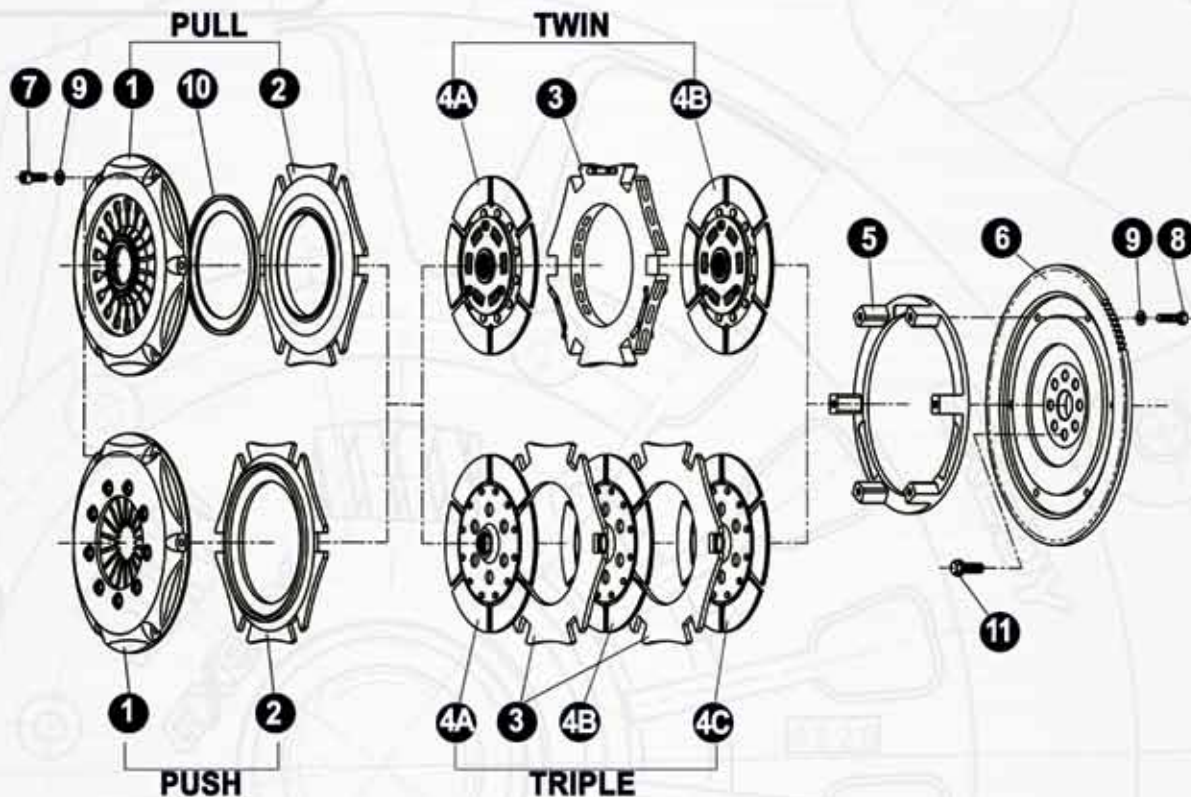

PART NO.	C.COVER	P. PLATE	I.M. PLATE	DISC Assy	DISC Assy	DISC Assy	SPLINE HUB	D.BOSS SET	F/W RING	FLY-WHEEL	COVER BOLT SET	BOLT SET	PIVOT RING	FLYWHEEL BOLT	SPECIAL SLEEVE/ BEARING
	1	2	3	4-A	4-B	4-C			5	6	7,9	8,9	10	11	
ET01SD	CT01S	---	IM07	DT01D	DT01D	---	---	---	---	FT01	BS09	---	---	---	---
ET02SD	CT01S	---	IM07	DT01D	DT01D	---	---	---	---	FT03	BS09	---	---	---	---
ET03SD	CT01S	---	IM07	DT02D	DT02D	---	---	---	---	FT01	BS09	---	---	---	---
ET04XD	CT01H	---	IM14	DT06DA	DT06DB	---	---	---	---	FT06	---	---	---	BS15	---
FM012SD	CM02S	PP02	IM01	DM16DA	DM16DB	---	---	---	FR01	FM13	BS05	BS01	PR01	BF08	---
FM013HB	CM02H	PP02	IM02	DL03R	DL03R	DL03R	CH10	---	FR01	FM13	BS05	BS01	PR01	BF08	---
FM022HD	CM29H	PP02	IM01	DM16DA	DM16DB	---	---	---	FR01	FM13	BS05	BS01	PR01	BF08	---
FM022SD	CM03S	PP02	IM01	DM16DA	DM16DB	---	---	---	FR01	FM13	BS05	BS01	PR01	BF08	---
FM022SDL	CM34S	PP09	IM05	DM35DA	DM35DB	---	---	DB02	---	FM24	BS05	---	PR02	BF08	---
FM023SB	CM03S	PP02	IM02	DL03R	DL03R	DL03R	CH10	---	FR01	FM13	BS05	BS01	PR01	BF08	---
FM032SD	CM61S	PP41	IM01	DM16DA	DM16DB	---	---	---	---	FM13	BS05	BS01	---	BF08	---
GT01SD	CT01S	---	IM07	DT02D	DT02D	---	---	---	---	FT02	BS09	---	---	---	---
GT04SD	CT01S	---	IM07	DT04D	DT04D	---	---	---	---	FT02	BS09	---	---	---	---
GT04XD	CH05H	---	IM07	DT05DA	DT05DB	---	---	---	---	FT02	---	---	---	---	---
HM012SD	CM08S	PP04	IM01	DM19DA	DM19DB	---	---	---	FR01	FM14	BS05	BS01	---	---	---
HM022SR	CM09S	PP05	IM04	DM22RA	DM22RB	---	---	DB05	---	FM15	BS05	BS01	---	---	---
HM032SBL	CM49S	PP06	IM05	DL01R	DL01R	---	CH11	DB02	---	FM55	BS05	---	---	---	---
HM042SR	CM09S	PP05	IM04	DM23RA	DM23RB	---	---	DB05	---	FM15	BS05	BS01	---	---	---

PART NO.	C. COVER	P. PLATE	I.M. PLATE	DISC Assy	DISC Assy	DISC Assy	SPLINE HUB	D.BOSS SET	F/W RING	FLY-WHEEL	COVER BOLT SET	BOLT SET	PIVOT RING	FLYWHEEL BOLT	SPECIAL SLEEVE/ BEARING
	1	2	3	4-A	4-B	4-C			5	6	7,9	8,9	10	11	
HM052SR	CM08S	PP42	IM02	DL05R	DL05R	---	CH11	---	---	FM66	BS05	BS01	PR05	---	---
MM022SBL	CM35S	PP09	IM05	DL01R	DL01R	---	CH07	DB02	---	FM23	BS05	---	PR02	---	---
MM022HD	CM06H	PP02	IM01	DM13DA	DM13DB	---	---	---	FR01	FM12	BS05	BS01	PR01	---	---
MM022SD	CM06S	PP02	IM01	DM13DA	DM13DB	---	---	---	FR01	FM12	BS05	BS01	PR01	---	---
MM023HR	CM06H	PP02	IM02	DL03R	DL03R	DL03R	CH16	---	FR01	FM12	BS05	BS01	PR01	---	---
MM023SR	CM06S	PP02	IM02	DL03R	DL03R	DL03R	CH16	---	FR01	FM12	BS05	BS01	PR01	---	---
MM062HD	CM06H	PP02	IM01	DM09DA	DM09DB	---	---	---	FR01	FM59	BS05	BS01	PR01	---	---
MM062SBL	CM35S	PP09	IM05	DL01R	DL01R	---	CH07	DB02	---	FM60	BS05	---	PR02	---	---
MM062SD	CM06S	PP02	IM01	DM09DA	DM09DB	---	---	---	FR01	FM59	BS05	BS01	PR01	---	---
MM063HB	CM06H	PP02	IM02	DL03R	DL03R	DL03R	CH16	---	FR01	FM59	BS05	BS01	PR01	---	---
MM063SB	CM06S	PP02	IM02	DL03R	DL03R	DL03R	CH16	---	FR01	FM59	BS05	BS01	PR01	---	---
NM012SD	CM01S	PP01	IM01	DM01DA	DM01DB	---	---	---	FR01	FM01	BS05	BS01	---	BF01	---
NM022SD	CM01S	PP01	IM01	DM01DA	DM01DB	---	---	---	FR01	FM02	BS05	BS01	---	BF08	---
NM032SD	CM01S	PP01	IM01	DM01DA	DM01DB	---	---	---	FR01	FM03	BS05	BS01	---	BF03	---
NM033HRW	CM01H	PP01	IM02	DL03R	DL03R	DL03R	CH12	---	FR01	FM03W	BS05	BS01	---	BF03	---
NM033HRWH	CM01H	PP01	IM02	DL03R	DL03R	DL03R	---	---	FR01	FM03W	BS05	BS01	---	BF03	---
NM033HRWT	CM01H	PP01	IM02	DL03R	DL03R	DL03R	---	---	FR01	FM03W	BS05	BS01	---	BF03	---
NM033SR	CM01S	PP01	IM02	DL03R	DL03R	DL03R	CH12	---	FR01	FM03	BS05	BS01	---	BF03	---
NM042SD	CM02S	PP02	IM01	DM01DA	DM01DB	---	---	---	FR01	FM03	BS05	BS01	PR01	BF03	---
NM043SR	CM02S	PP02	IM02	DL03R	DL03R	DL03R	CH12	---	FR01	FM03	BS05	BS01	PR01	BF03	---
NM052SD	CM03S	PP02	IM01	DM01DA	DM01DB	---	---	---	FR01	FM04	BS05	BS01	PR01	BF03	---
NM053SR	CM03S	PP02	IM02	DL03R	DL03R	DL03R	CH12	---	FR01	FM04	BS05	BS01	PR01	BF03	---
NM062SD	CM01S	PP01	IM01	DM01DA	DM01DB	---	---	---	FR01	FM05	BS05	BS01	---	---	---
NM063SR	CM01S	PP01	IM02	DL03R	DL03R	DL03R	CH12	---	FR01	FM05	BS05	BS01	---	---	---
NM072HD	CM01H	PP01	IM01	DM01DA	DM01DB	---	---	---	---	FM34	BS05	BS01	---	---	---
NM092SD	CM01H	PP01	IM01	DM01DA	DM01DB	---	---	---	FR01	FM56	BS05	BS01	---	BF03	---
NM093HB	CM01H	PP01	IM02	DL03R	DL03R	DL03R	CH12	---	FR01	FM56	BS05	BS01	---	BF03	---
RM012SD	CM60H	PP41	IM01	DM38DA	DM38DB	---	---	---	---	FM65	BS05	BS01	---	---	---
TM012SR	CM01S	PP01	IM03	DM04RA	DM04RB	---	---	---	FR02	FM06	BS06	---	---	BF04	RB01
TM032SD	CM04S	PP03	IM01	DM05DA	DM05DA	---	---	---	FR01	FM09	BS05	BS01	---	---	---
TM042SD	CM05S	PP03	IM01	DM07DA	DM07DA	---	---	---	FR01	FM09	BS05	BS01	---	---	---
TM043SR	CM05S	PP03	IM02	DL03R	DL03R	DL03R	CH15	---	FR01	FM09	BS05	BS01	---	---	---
ZM012SD	CM01S	PP01	IM01	DM09DA	DM09DB	---	---	---	FR01	FM10	BS05	BS01	---	BF07	---
ZM013HR	CM01H	PP01	IM02	DL03R	DL03R	DL03R	CH16	---	FR01	FM10	BS05	BS01	---	BF07	---
ZM013SR	CM01S	PP01	IM02	DL03R	DL03R	DL03R	CH16	---	FR01	FM10	BS05	BS01	---	BF07	---
ZM022SD	CM02S	PP02	IM01	DM09DA	DM09DB	---	---	---	FR01	FM10	BS05	BS01	PR01	BF07	---
ZM023HR	CM02H	PP02	IM02	DL03R	DL03R	DL03R	CH16	---	FR01	FM10	BS05	BS01	PR01	BF07	---
ZM023SR	CM02S	PP02	IM02	DL03R	DL03R	DL03R	CH16	---	FR01	FM10	BS05	BS01	PR01	BF07	---

Hyper Carbon Multi-Plate Repair Parts

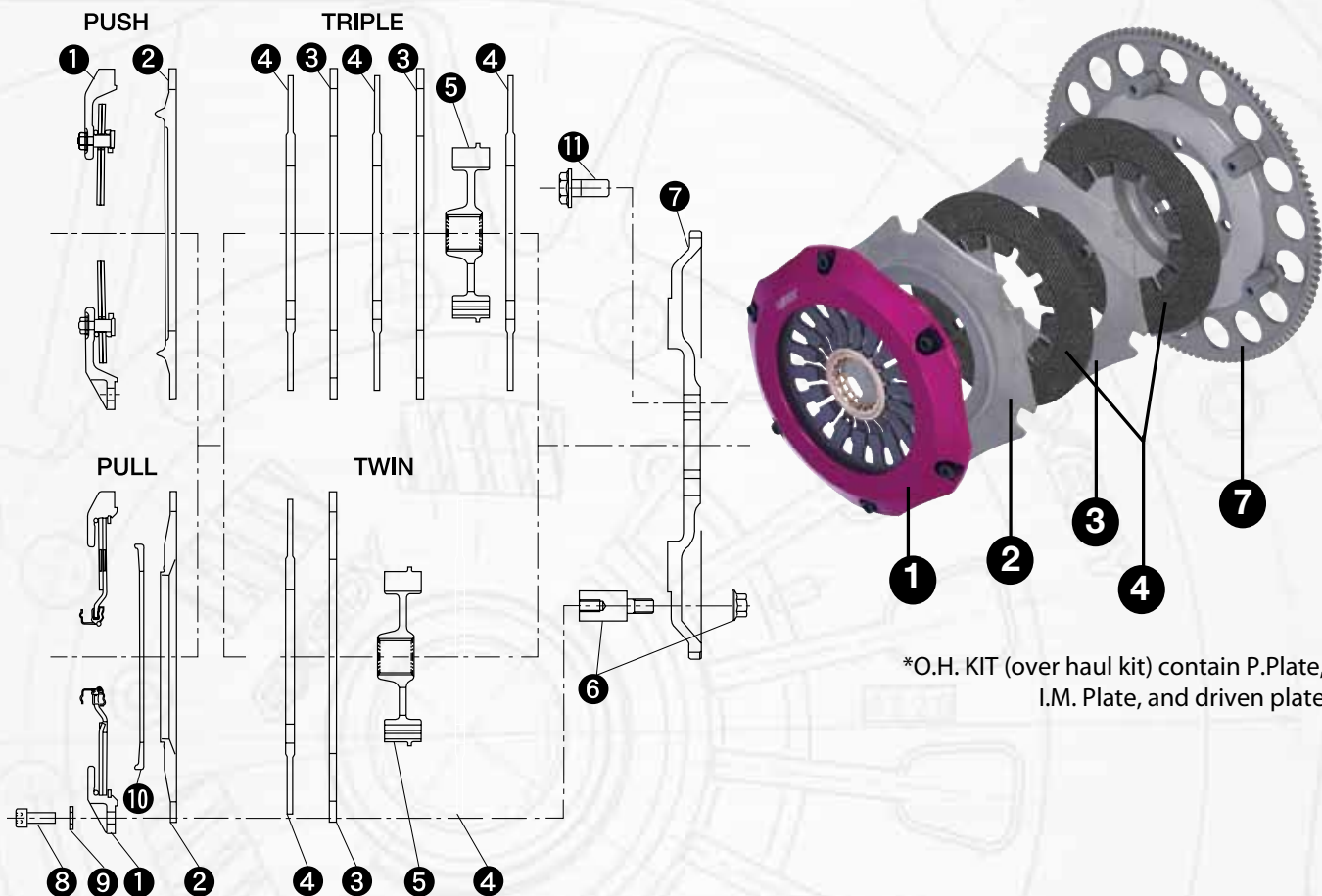

PART NO.	C.COVER	PRESS PLATE	I.M. PLATE	DRVN PLATE	SPLINE HUB/ DAMPER	D. BOSS SET	F/W	BOLT SET	PVT. RING	BOLT F/W
	1	2	3	4	5	6	7	8 & 9	10	11
FM012SBMC	CM40S	PP09	IM12	DP01	SH08	DB02	FM24	BS05	PR05	BF08
FM012SDMC1	CM32S	PP19	IM11	DP03	DD03	BU03	FM38	BS07	PR06	BF08
FM022SBMC1	CM34S	PP09	IM12	DP01	SH08	DB02	FM24	BS05	PR05	BF08
FM022SDMC1	CM46S	PP19	IM11	DP03	DD03	BU03	FM38	BS07	PR06	BF08
FM023SBMC1	CM40S	PP09	IM12	DP01	SH36	DB01	FM54	BS05	PR05	BF08
GM013SBMC1	CM27S	PP23	IM11	DP02	SH21	BU02	FM45	BS07	---	---
HM012SBMC1	CM38S	PP27	IM12	DP01	SH23	DB01	FM25	BS05	---	---
HM052SBMC	CM38S	PP28	IM12	DP01	SH23	DB02	FM46	BS05	---	---
MM022HBMC	CM13H	PP09	IM05	DP01	SH07	DB02	FM23	BS05	PR02	---
MM022SDMC1	CM45S	PP19	IM11	DP03	DD02	BU03	FM35	BS07	PR06	---
MM023HBMC1	CM19H	PP09	IM05	DP01	SH19	DB01	FM32	BS05	PR02	---
MM062SDMC1	CM45S	PP19	IM11	DP03	DD02	BU03	FM61	BS07	PR06	---

PART NO.	C. COVER	PRESS PLATE	I.M. PLATE	DRVN PLATE	SPLINE HUB/ DAMPER	D. BOSS SET	F/W	BOLT SET	PVT. RING	BOLT F/W
	1	2	3	4	5	6	7	8 & 9	10	11
NM012SBMC	CM39S	PP25	IM12	DP01	SH04	DB02	FM16	BS05	---	BF01
NM013SBMC	CM39S	PP25	IM12	DP01	---	DB01	FM30	BS05	---	BF01
NM022SBMC	CM39S	PP26	IM12	DP01	SH04	DB01	FM17	BS05	---	BF08
NM032SBMC	CM39S	PP26	IM12	DP01	SH33	DB01	FM18	BS05	---	BF03
NM032SDMC	CM31S	PP32	IM11	DP03	DD01	BU02	FM36	BS07	---	BF03
NM033SBMC	CM39S	PP25	IM12	DP01	SH33	DB01	FM18	BS05	---	BF03
NM042SBMC	CM40S	PP07	IM12	DP01	SH33	DB01	FM18	BS05	PR05	BF03
NM042SDMC1	CM48S	PP15	IM11	DP03	DD01	BU02	FM36	BS07	PR06	BF03
NM043SBMC	CM40S	PP09	IM12	DP01	SH33	DB01	FM18	BS05	PR05	BF03
NM052SBMC	CM34S	PP07	IM12	DP01	SH33	DB01	FM20	BS05	PR05	BF03
NM052SDMC1	CM46S	PP15	IM11	DP03	DD01	BU02	FM33	BS07	PR06	BF03
NM053SBMC	CM34S	PP09	IM12	DP01	SH33	DB01	FM20	BS05	PR05	BF03
NM062SBMC	CM39S	PP26	IM12	DP01	SH33	DB01	FM31	BS05	---	BF10
NM063SBMC	CM39S	PP25	IM12	DP01	SH33	DB01	FM31	BS05	---	BF10
NM072SBMC1	CM39S	PP26	IM12	DP01	SH33	DB01	FM27	BS05	---	BF08
NM072SDMC1	CM31S	PP32	IM11	DP03	DD01	BU02	FM40	BS07	---	---
NMA73HBMC1	CM52H	PP23	IM11	DP02	SH38	BU02	FM58	BS07	---	---
NT01HDMC	CT04H	---	IM13	DP03	DD06	---	FT05	---	---	---
PM012SDMC1	CM53S	PP43	IM11	DP03	DD07	---	FM67	BS12	PR06	---
PM013SBMC1	CM53S	PP44	IM11	DP03	SH40	---	FM67	BS12	PR06	---
TM032SBMC	CM36S	PP27	IM12	DP01	SH06	DB01	FM26	BS05	---	---
TM032SDMC	CM47S	PP15	IM11	DP03	DD04	BU02	FM39	BS07	PR06	---
TM033SBMC	CM36S	PP28	IM12	DP01	SH06	DB01	FM26	BS05	---	---
TM042SBMC1	CM37S	PP27	IM12	DP01	SH15	DB01	FM26	BS05	---	---
TM042SDMC	CM33S	PP15	IM11	DP03	DD05	BU02	FM39	BS07	PR06	---
TM043SBMC1	CM37S	PP28	IM12	DP01	SH15	DB01	FM26	BS05	---	---
TM043HBMC	CM51H	PP24	IM08	DP02	SH15	BU02	FM39	BS07	---	---
ZM012SBMC	CM39S	PP25	IM12	DP01	SH07	DB02	FM22	BS05	---	BF07
ZM022SBMC1	CM40S	PP09	IM12	DP01	SH07	DB02	FM22	BS05	PR05	BF07
ZM022SDMC1	CM46S	PP19	IM11	DP03	DD02	BU03	FM37	BS07	PR06	BF07
ZM023SBMC	CM40S	PP09	IM12	DP01	SH31	DB01	FM29	BS05	PR05	BF07

Conversions

To Convert	Formula
Cubic Inches to Liters	LITERS times 61.024 equals CUBIC INCHES
Liters to Cubic Inches	CUBIC INCHES divided by 61.024 equals LITERS

LITERS	CC/CI	LITERS	CC/CI	LITERS	CC/CI	LITERS	CC/CI
1.0L	61	1.6L	97	1.9L	116	2.2L	2180
1.0L	948	1.6L	98	1.9L	119	2.2L	2184
1.0L	995	1.6L	1565	1.9L	1858	2.2L	2187
1.0L	1000	1.6L	1573	1.9L	1872	2.2L	2189
1.0L	1146	1.6L	1586	1.9L	1895	2.2L	2195
1.1L	1100	1.6L	1587	1.9L	1896	2.2L	2197
1.1L	1116	1.6L	1588	1.9L	1898	2.2L	2200
1.1L	1146	1.6L	1588	1.9L	1900	2.2L	2212
1.2L	1166	1.6L	1589	1.9L	1915	2.2L	2226
1.2L	1189	1.6L	1590	1.9L	1949	2.2L	2237
1.2L	1196	1.6L	1595	2.0L	121	2.3L	138
1.2L	1200	1.6L	1596	2.0L	122	2.3L	140
1.2L	1237	1.6L	1597	2.0L	1952	2.3L	173
1.3L	79	1.6L	1599	2.0L	1955	2.3L	2253
1.3L	81	1.6L	1600	2.0L	1958	2.3L	2254
1.3L	1272	1.6L	1606	2.0L	1967	2.3L	2259
1.3L	1275	1.6L	1639	2.0L	1968	2.3L	2290
1.3L	1289	1.7L	104	2.0L	1970	2.3L	2295
1.3L	1290	1.7L	1678	2.0L	1971	2.3L	2299
1.3L	1295	1.7L	1700	2.0L	1972	2.3L	2300
1.3L	1300	1.7L	1715	2.0L	1974	2.3L	2302
1.3L	1301	1.7L	1721	2.0L	1975	2.3L	2307
1.3L	1308	1.8L	107	2.0L	1983	2.3L	2309
1.3L	1328	1.8L	110	2.0L	1984	2.3L	2316
1.3L	1335	1.8L	112	2.0L	1985	2.3L	2341
1.3L	1342	1.8L	113	2.0L	1986	2.4L	145
1.4L	85	1.8L	1590	2.0L	1989	2.4L	146
1.4L	1393	1.8L	1597	2.0L	1990	2.4L	148
1.4L	1397	1.8L	1751	2.0L	1991	2.4L	150
1.4L	1400	1.8L	1754	2.0L	1994	2.4L	2351
1.4L	1410	1.8L	1760	2.0L	1997	2.4L	2366
1.4L	1415	1.8L	1762	2.0L	1998	2.4L	2389
1.5L	90	1.8L	1770	2.0L	2792	2.4L	2393
1.5L	92	1.8L	1780	2.1L	126	2.4L	2398
1.5L	1452	1.8L	1781	2.1L	2056	2.4L	2400
1.5L	1456	1.8L	1790	2.1L	2100	2.4L	2435
1.5L	1457	1.8L	1793	2.1L	2109	2.4L	2438
1.5L	1468	1.8L	1795	2.1L	2119	2.5L	148
1.5L	1471	1.8L	1796	2.1L	2127	2.5L	150
1.5L	1475	1.8L	1797	2.2L	132	2.5L	151
1.5L	1487	1.8L	1798	2.2L	133	2.5L	152
1.5L	1488	1.8L	1800	2.2L	134	2.5L	153
1.5L	1489	1.8L	1809	2.2L	135	2.5L	173
1.5L	1490	1.8L	1817	2.2L	2109	2.5L	262
1.5L	1491	1.8L	1829	2.2L	2144	2.5L	2451
1.5L	1493	1.8L	1834	2.2L	2147	2.5L	2458
1.5L	1495	1.8L	1836	2.2L	2155	2.5L	2459
1.5L	1497	1.8L	1839	2.2L	2156	2.5L	2475
1.5L	1500	1.8L	1840	2.2L	2163	2.5L	2492
1.5L	1508	1.8L	1845	2.2L	2164	2.5L	2493

To Convert	Formula
Cubic Inches to Liters	LITERS times 61.024 equals CUBIC INCHES
Liters to Cubic Inches	CUBIC INCHES divided by 61.024 equals LITERS

LITERS	CC/CI	LITERS	CC/CI	LITERS	CC/CI	LITERS	CC/CI
2.5L	2494	3.0L	2966	3.8L	230	5.5L	330
2.5L	2497	3.0L	2967	3.8L	231	5.6L	340
2.5L	2498	3.0L	2969	3.8L	232	5.6L	343
2.5L	2500	3.0L	2972	3.8L	3800	5.6L	5576
2.5L	2508	3.0L	2980	3.9L	235	5.7L	347
2.6L	156	3.0L	2983	3.9L	240	5.7L	348
2.6L	2555	3.0L	2985	3.9L	2950	5.7L	350
2.6L	2557	3.0L	2988	3.9L	3900	5.7L	351
2.6L	2559	3.0L	2997	3.9L	3950	5.8L	351
2.6L	2563	3.0L	2999	4.0L	242	5.8L	352
2.6L	2565	3.0L	3000	4.0L	244	5.8L	354
2.6L	2588	3.1L	189	4.0L	3950	5.8L	5800
2.6L	2597	3.1L	191	4.0L	3982	5.9L	360
2.6L	2599	3.1L	3137	4.0L	4016	5.9L	361
2.6L	2600	3.2L	194	4.1L	250	6.0L	363
2.6L	2606	3.2L	196	4.2L	255	6.1L	370
2.7L	165	3.2L	198	4.2L	258	6.2L	379
2.7L	167	3.2L	3165	4.2L	4172	6.3L	383
2.7L	294	3.2L	3179	4.2L	4196	6.4L	389
2.7L	2656	3.2L	3200	4.2L	4200	6.4L	390
2.7L	2671	3.2L	3206	4.3L	260	6.4L	391
2.7L	2672	3.3L	185	4.3L	261	6.5L	395
2.7L	2673	3.3L	200	4.3L	262	6.5L	396
2.7L	2675	3.3L	3210	4.3L	265	6.6L	400
2.7L	2688	3.3L	3230	4.3L	4294	6.6L	401
2.7L	2693	3.3L	3275	4.4L	265	6.6L	402
2.7L	2694	3.3L	3294	4.4L	267	6.6L	403
2.7L	2700	3.3L	3300	4.4L	270	6.6L	406
2.8L	170	3.4L	204	4.5L	273	6.7L	409
2.8L	171	3.4L	207	4.6L	281	6.8L	413
2.8L	173	3.4L	3378	4.6L	283	6.8L	415
2.8L	231	3.4L	3400	4.7L	285	6.9L	420
2.8L	2753	3.4L	3431	4.7L	287	6.9L	421
2.8L	2754	3.5L	212	4.7L	289	7.0L	425
2.8L	2771	3.5L	3430	4.8L	290	7.0L	427
2.8L	2788	3.5L	3453	4.8L	292	7.0L	428
2.8L	2792	3.5L	3475	4.8L	294	7.0L	429
2.8L	2793	3.5L	3500	4.9L	300	7.2L	439
2.8L	2800	3.5L	3524	4.9L	301	7.2L	440
2.8L	2827	3.5L	3540	5.0L	302	7.3L	446
2.8L	2849	3.5L	3543	5.0L	304	7.4L	454
2.9L	177	3.6L	221	5.0L	305	7.4L	455
2.9L	179	3.6L	223	5.0L	307	7.5L	455
3.0L	181	3.6L	3562	5.0L	4950	7.5L	460
3.0L	182	3.6L	3590	5.2L	316	7.8L	477
3.0L	183	3.6L	3596	5.2L	318	8.0L	488
3.0L	2954	3.6L	3606	5.3L	326	8.0L	490
3.0L	2959	3.7L	225	5.4L	327	8.1L	496
3.0L	2960	3.7L	226	5.4L	329	8.3L	505
3.0L	2961	3.8L	229	5.4L	330		

Conversions

To Convert	Formula
Millimeters to Inches	MILLIMETERS divided by 25.4 equals INCHES
Inches to Millimeters	INCHES times 25.4 equals MILLIMETERS

DISC (IN)	DISC (MM)	DISC (IN)	DISC (MM)	DISC (IN)	DISC (MM)	DISC (IN)	DISC (MM)
6-1/4	159	8-5/16	211	9-3/8	238	10-7/8	276
6-5/16	160	8-3/8	213	9-7/16	240	11	279
6-1/2	165	8-7/16	214	9-1/2	241	11-1/2	292
6-11/16	170	8-1/2	216	9-5/8	244	11-3/4	298
6-3/4	172	8-5/8	219	9-11/16	246	11-13/16	300
7	178	8-3/4	222	9-3/4	248	11-7/8	302
7-1/8	181	8-13/16	224	9-7/8	248	12	305
7-1/4	184	8-7/8	225	10	254	12-1/4	311
7-3/8	187	9	229	10-1/8	257	12-3/4	324
7-1/2	190	9-1/16	230	10-1/4	260	12-13/16	325
7-7/8	200	9-1/8	232	10-3/8	264	13	330
8	203	9-1/4	235	10-1/2	267	14	356
8-1/4	210	9-5/16	237	10-3/4	273	15	381

To Convert	Formula
Millimeters to Inches	MILLIMETERS divided by 25.4 equals INCHES
Inches to Millimeters	INCHES times 25.4 equals MILLIMETERS

DISC (MM)	DISC (IN)	DISC (MM)	DISC (IN)	DISC (MM)	DISC (IN)	DISC (MM)	DISC (IN)
159	6-1/4	213	8-3/8	241	9-1/2	298	11-3/4
160	6-5/16	214	8-7/16	244	9-5/8	300	11-13/16
165	6-1/2	216	8-1/2	246	9-11/16	302	11-7/8
170	6-11/16	219	8-5/8	248	9-3/4	305	12
172	6-3/4	222	8-3/4	248	9-7/8	311	12-1/4
178	7	224	8-13/16	254	10	324	12-3/4
181	7-1/8	225	8-7/8	257	10-1/8	325	12-13/16
184	7-1/4	229	9	260	10-1/4	330	13
187	7-3/8	230	9-1/16	264	10-3/8	352	13-7/8
190	7-1/2	232	9-1/8	267	10-1/2	356	14
200	7-7/8	235	9-1/4	273	10-3/4	381	15
203	8	237	9-5/16	276	10-7/8	14	356
210	8-1/4	238	9-3/8	279	11	15	381

A large white rectangular area with horizontal lines for writing, set against a background of faint technical drawings and a gear-like pattern.

Overseas Network

● Direct Investment (Production) ● Direct Investment (Sales/Production)

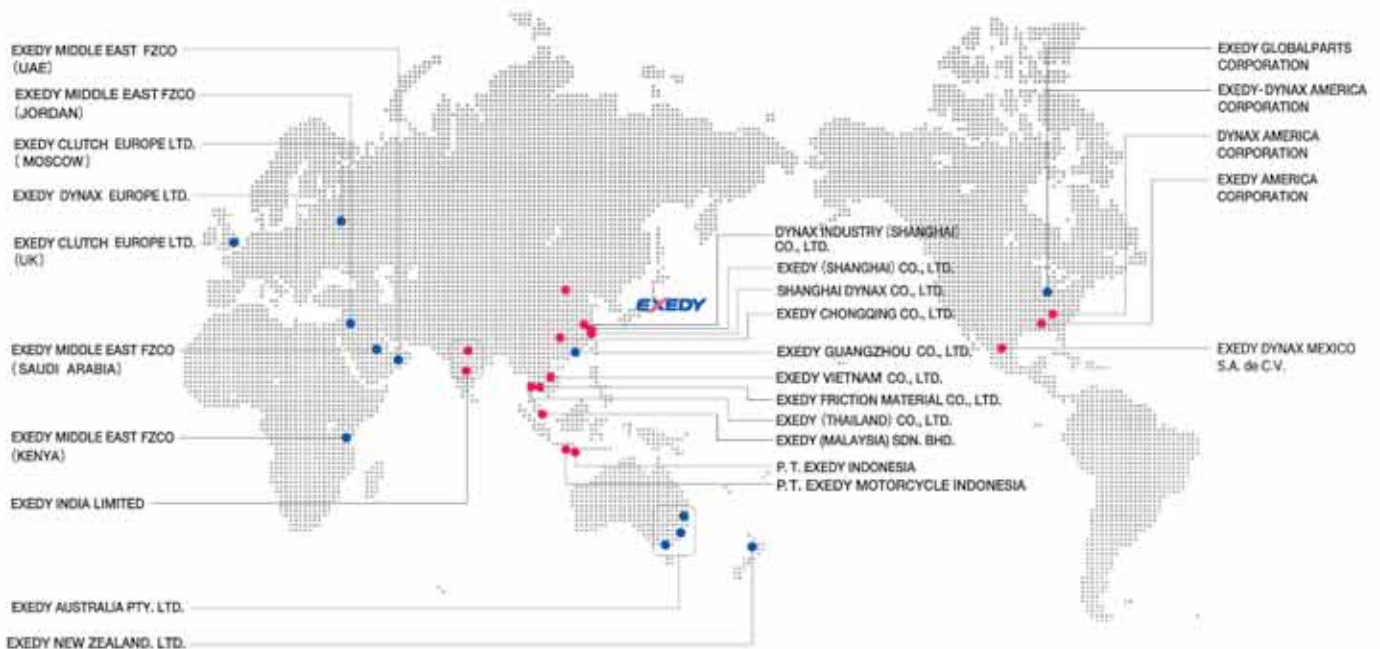

EXEDY GLOBALPARTS CORPORATION
8601 HAGGERTY RD. SOUTH
BELLEVILLE, MI 48111

www.exedyusa.com
800.346.6091