

Serafim R1/R1+

Serafim Racing Wheel for Smartphones, Consoles, and PC

User Manual



Contents

Disclaimer	2
Warranty	3
Package Contents	4
Component Names	6
How to Use	8
Button Customization	15
R1+: How to play on consoles.....	25
R1/R1+: How to play on PC	29
Product Specification	32
Key Mapping	34
Safety Notes	36
Troubleshooting	39
Compliance Information	44
Setup Guide	50

Disclaimer

Copyright©

© Serafim Tech. Inc. All rights reserved.

No part of this manual, including the products and software described in it, may be reproduced, transmitted, transcribed, stored in a retrieval system, or any without the express written permission of Serafim Tech. Inc.

For any future information please visit Serafim official website: <http://www.serafim-tech.com> if however, you encounter any problems we would be glad to answer all your concerns at sales@serafim-tech.com.

Warranty

This product has one-year Serafim warranty service, only in these following cases should not be content into warranty of Serafim:

1. The product is repaired, modified or altered, unless such repair, modification or alteration is authorized in written form by Serafim.
2. In all cases the commencement date for the period is one year since the actual day of purchase, as reflected on the authorized reseller's or distributor's invoice / receipt provided to you.

Package Contents of R1+

1



2



3



4

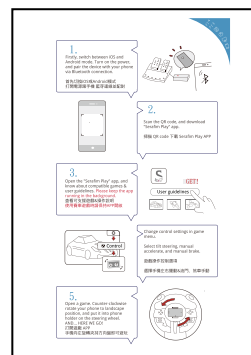

1. Racing wheel & phone holder

2. Racing pedals

3. Bluetooth box

4. Quick setup guide

*** These pictures are for reference only**

Package Contents of R1

1



2

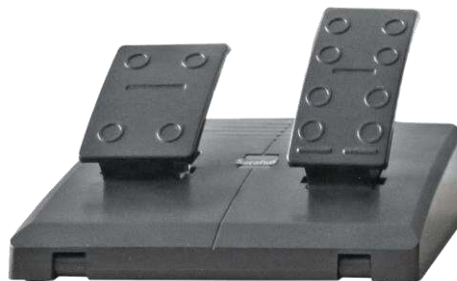

3



4

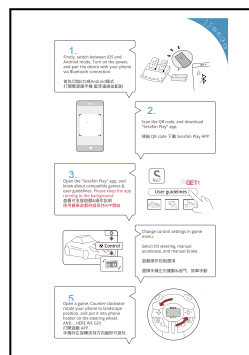

5. Racing wheel & phone holder

6. Racing pedals

7. Bluetooth box

8. Quick setup guide

*** These pictures are for reference only**

Component Names of R1+

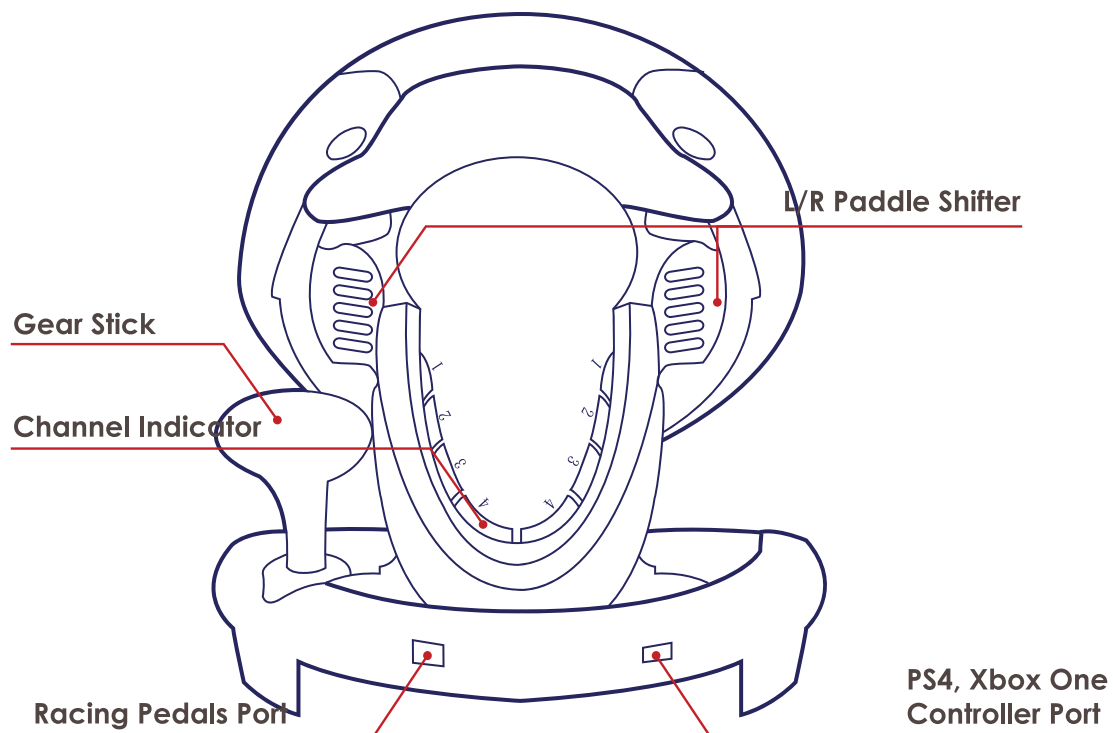
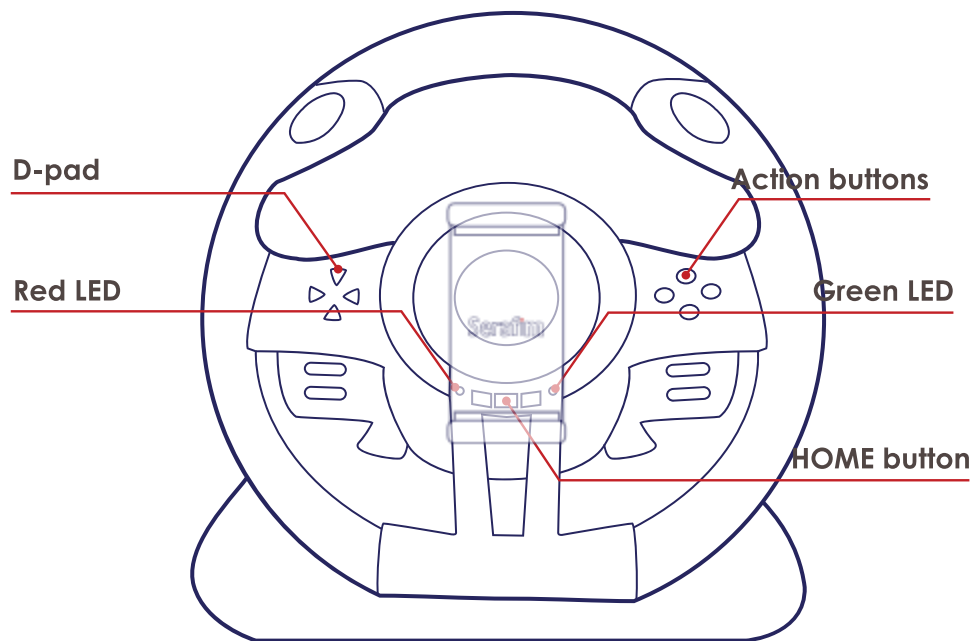

Component Names of R1:

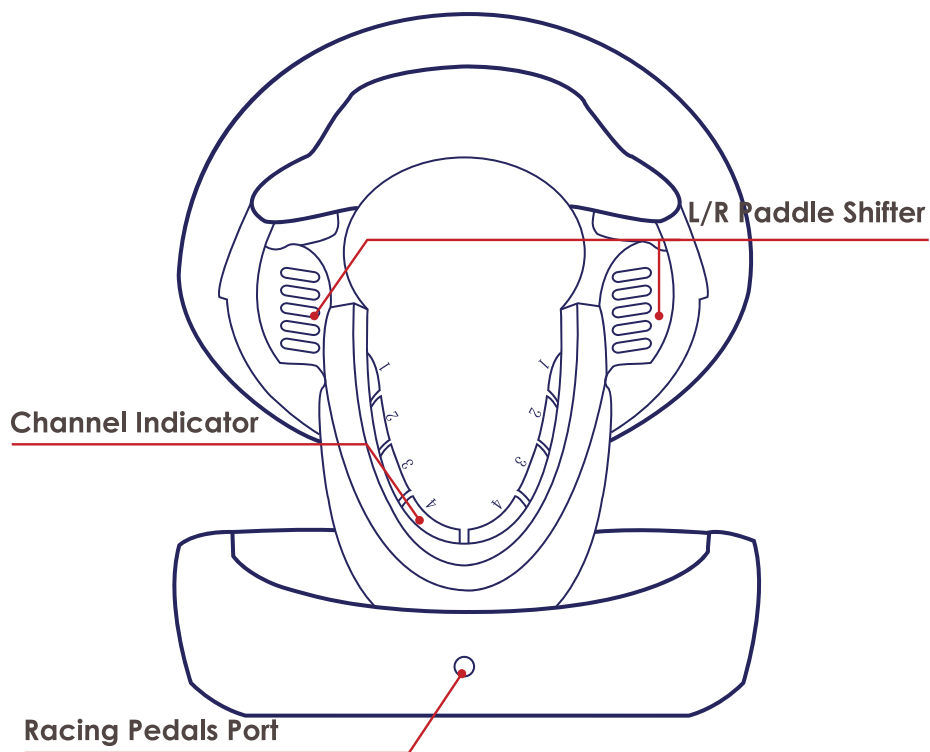
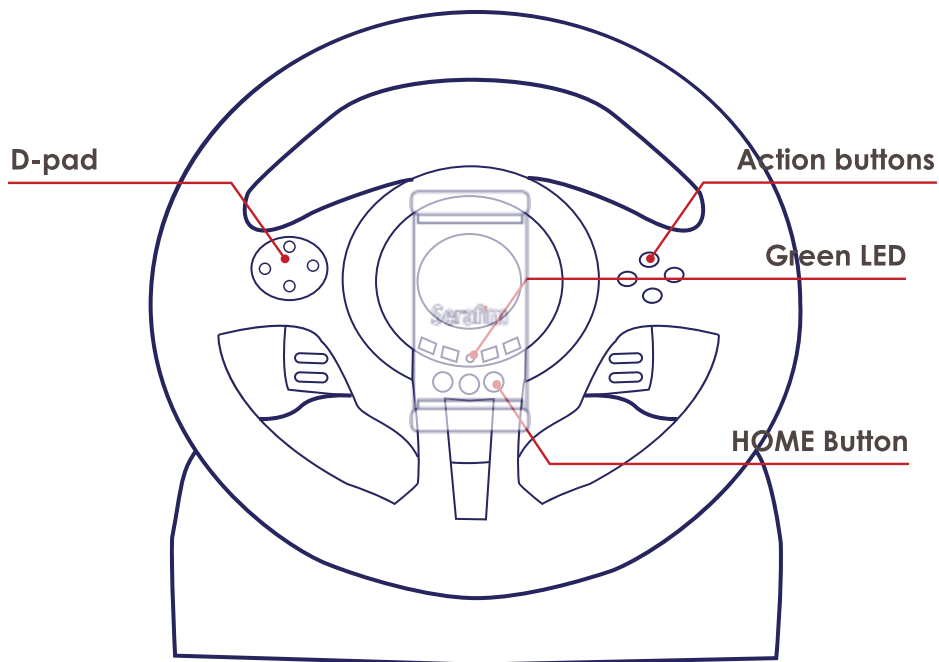

How to Use

Instructions for Using the Product:

1. Firstly, get a “Serafim Play” app for free on App Store or Google Play.



2. Next, switch between Android and iOS mode on a Bluetooth module. Connect Bluetooth module to pedals and press the power button for 3 seconds to turn on the module. Pair the device with your phone via Bluetooth. The blinking speed of indicator will be slower when the connection is successful.

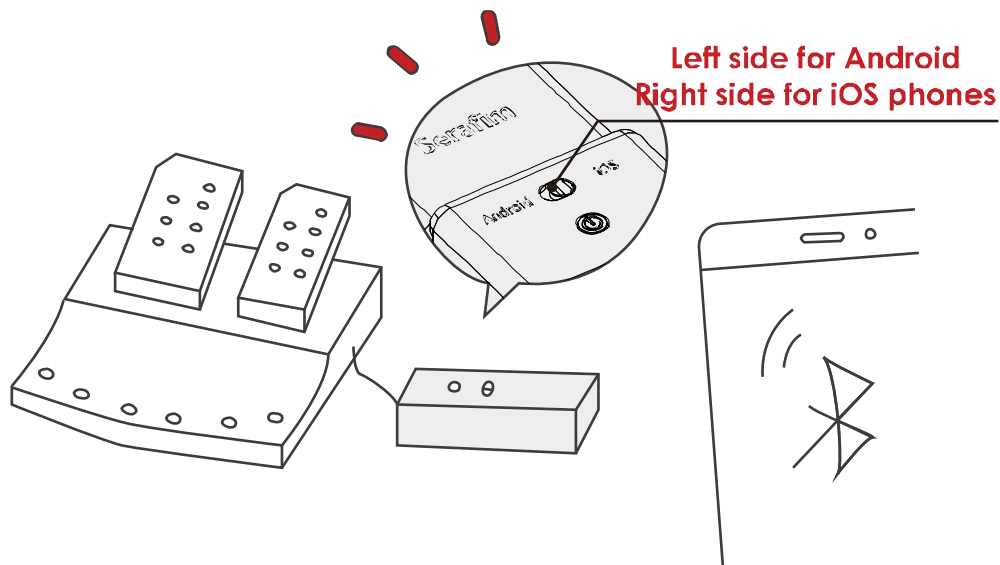

Open “Serafim Play” app, and the app will automatically pair with Serafim R1+ via Bluetooth.

3. For Android, Please keep “Serafim Play” running in the background, and launch a game.

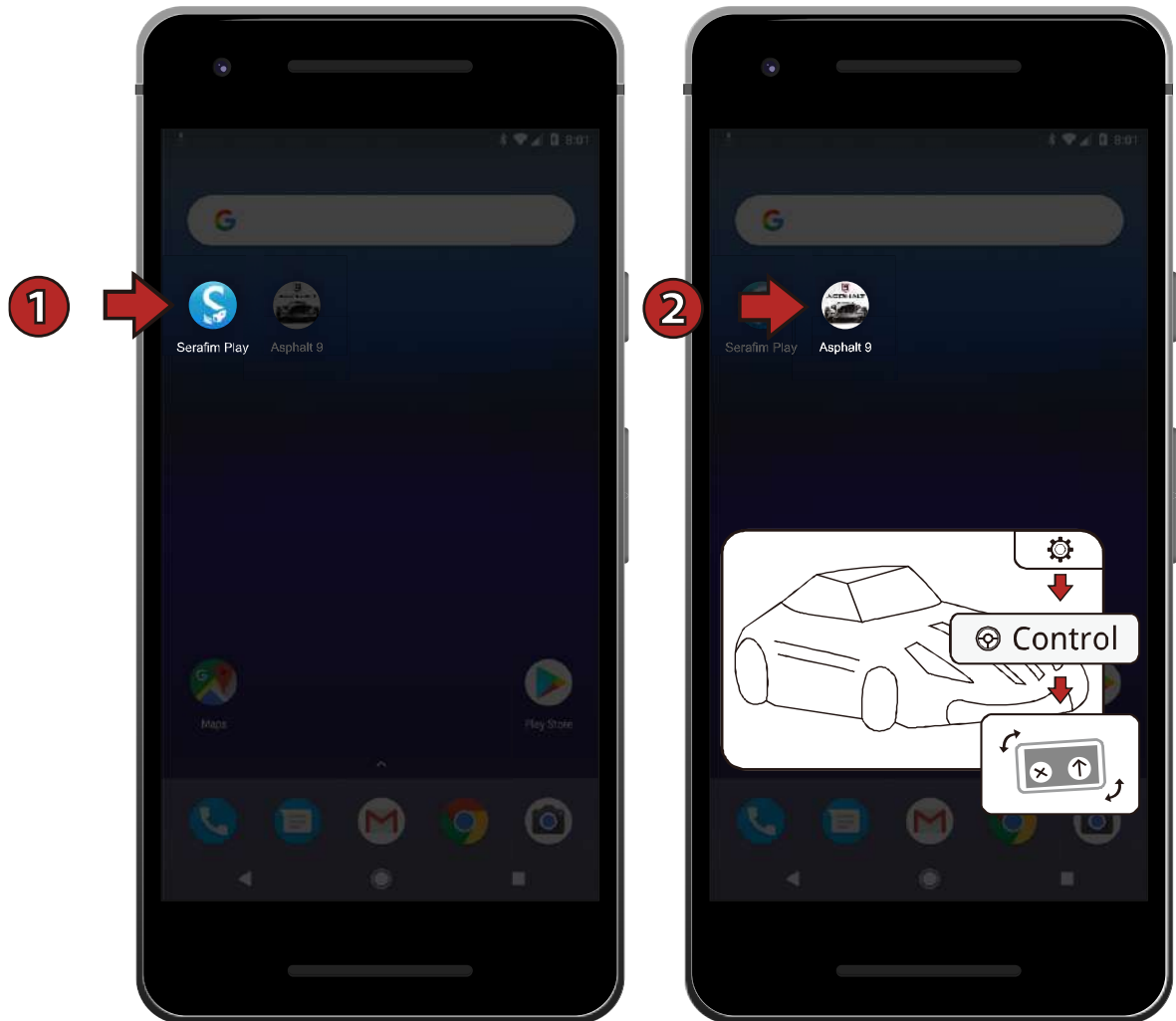

4. For iOS, apply settings for your game in “Serafim Play”, and launch the game.



5. Counter-clockwise rotate your phone to landscape position; put the phone into phone holder on the wheel, and you are good to go.

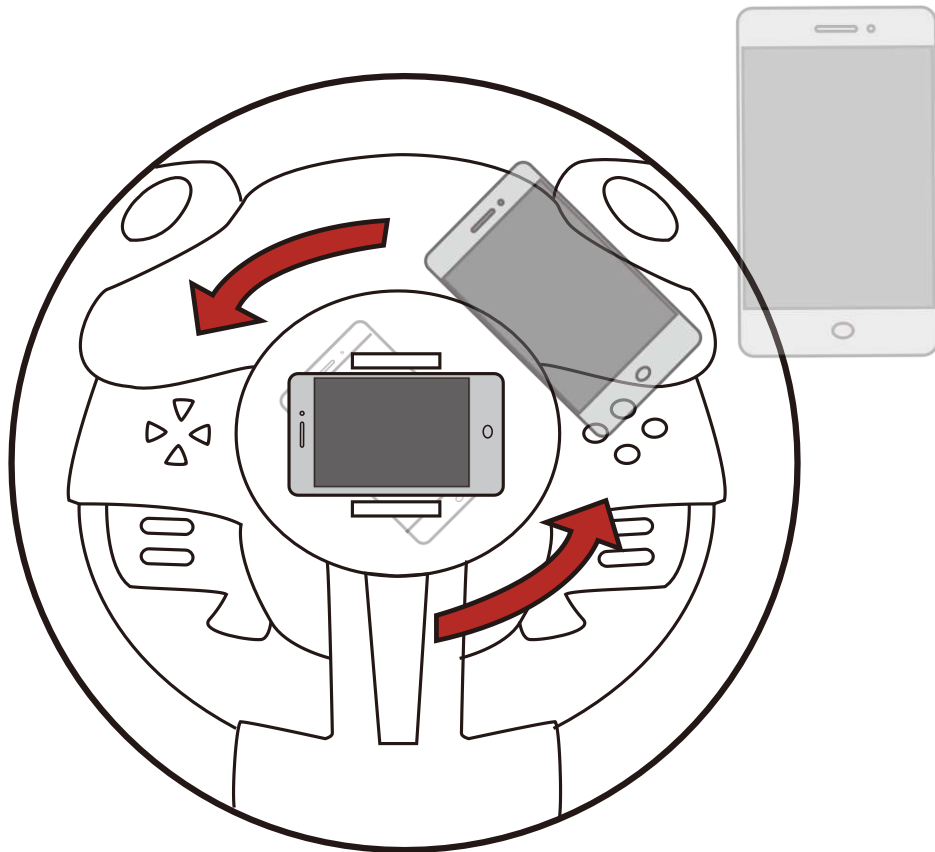

6. Change driving setting in game menu

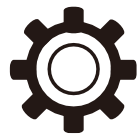

Setting



Control



Select tilt steering, manual accelerate, and manual brake

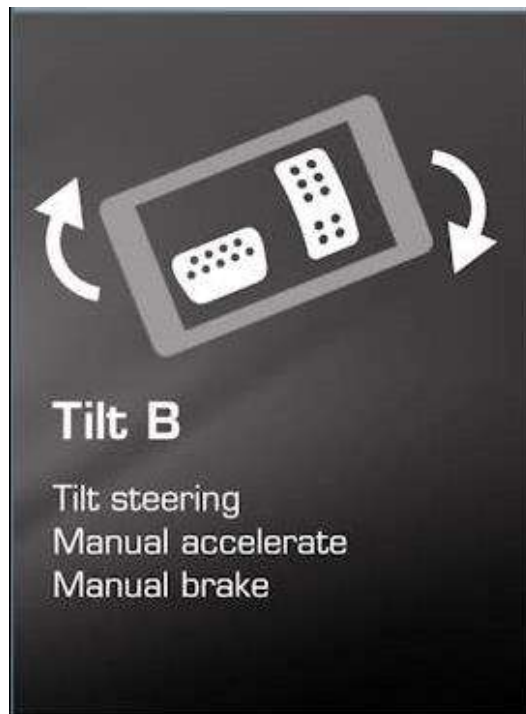

* Actual steering settings may vary from game to game.
For more information, please visit <http://www.serafim-tech.com/serafim-r1/serafim-r1-user-manual-en.html>

7. Compatible games:



Real Racing 3



CarXDrift Racing



Asphalt 8



Traffic Rider



CarXDrift Racing 2



Hill Climb Racing



RealMoto



Racing Fever



F1 Mobile Racing



Gear.Club - Tune Racing



Car Driving School Simulator



Traffic Racer



SBK 16 Official Mobile Game



Asphalt 9 Legends



Traffic Tour



GT Racing 2



MMX Hill Dash - Off Road Racing



M.U.D. Rally

More than 19 games support for iPhone and Android Phone.

8. Other compatible consoles for Serafim Racing Wheel

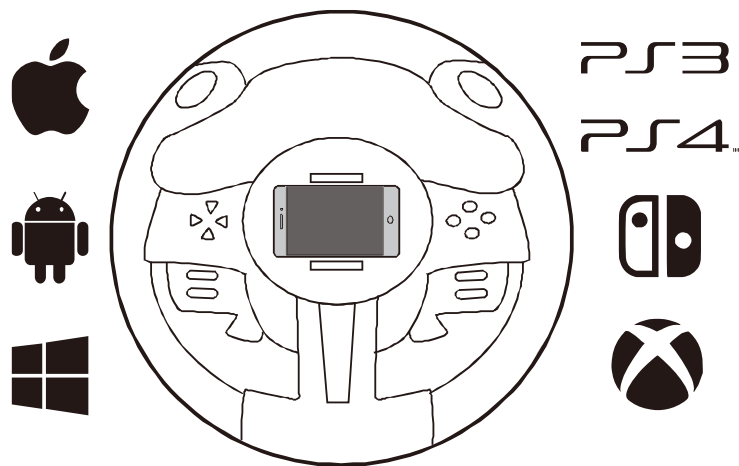

- Serafim R1+ supports 7 platforms, which are PS3, PS4, Xbox One, Switch, PC Windows, Android, and iOS.
- Serafim R1 supports 3 platforms, which are PC Windows, Android, and iOS.

Button Customization

For Serafim R1+

1. Customizable Buttons: Action keys (□/1/X/Y, ○/3/B/A, △/4/Y/X, X/2/A/B) L1/5/LB/L L2/7/LT/ZL, R1/6/RB/R, R2/8/RT/ZR.

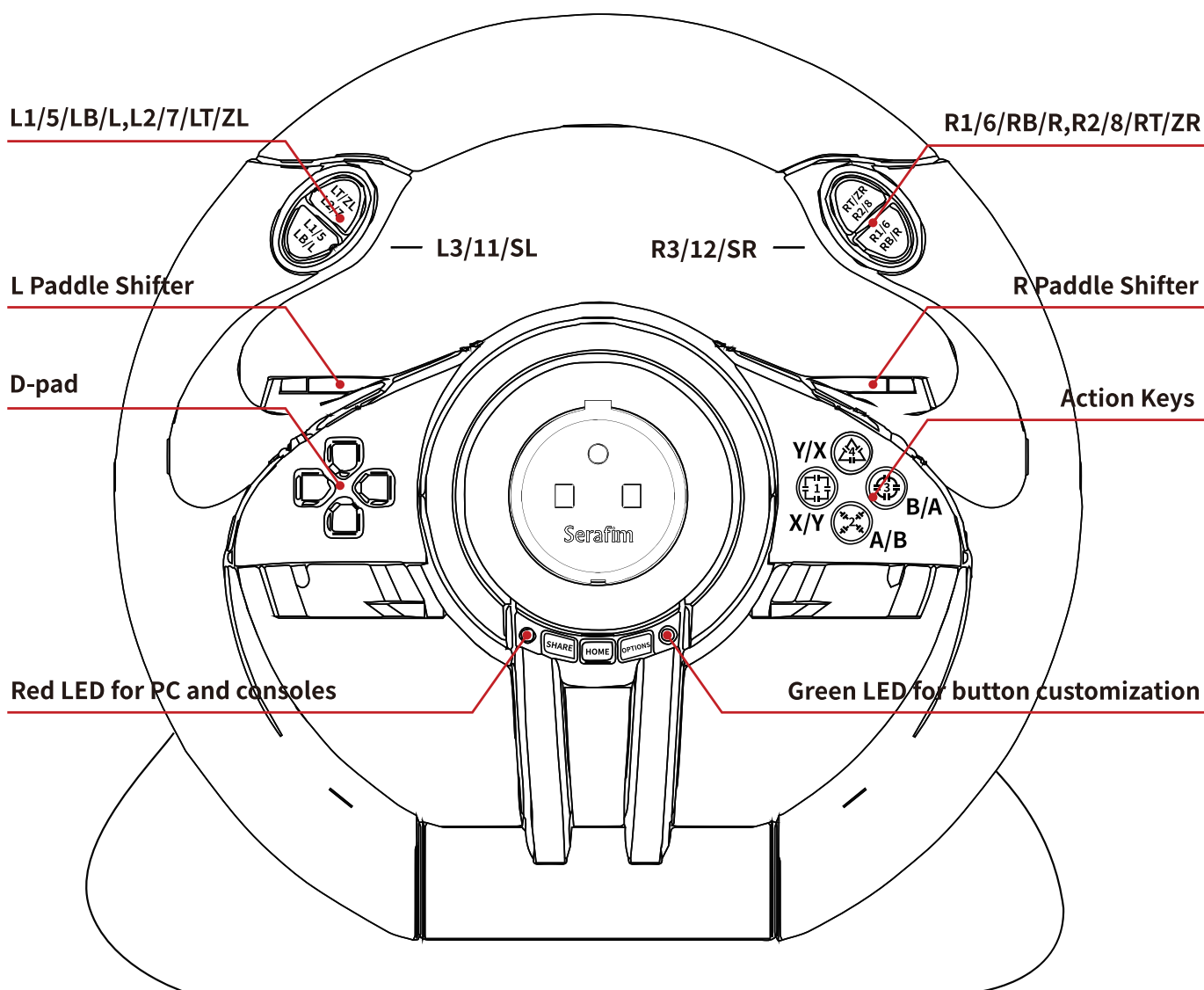

2. Buttons for Replacement: Left paddle

shifter(□/1/LT), R paddle shifter(X/2/RT),
Gas pedal (X/2/RT), Brake pedal(□/1/LT),
L3/11/SL, R3/12/SR、 Gear stick(Move
forward to press R1, back for L1)

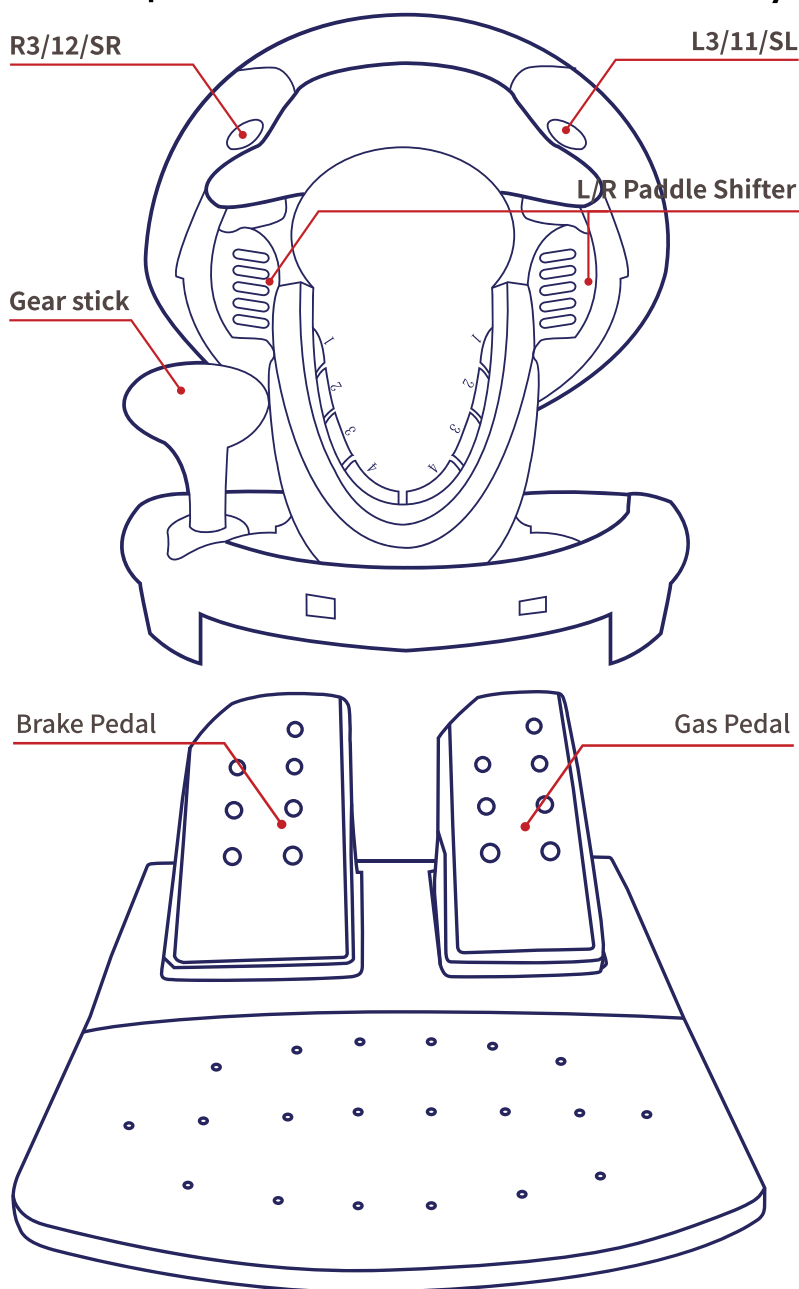

3. Procedures for Customizing Buttons:

(1) Hold SHARE and OPTIONS buttons for 3

seconds, and the green LED would be lit.

- (2)** Firstly, press one of “Buttons for Replacement”; then the green LED starts blinking.
- (3)** Press one of “Customizable Buttons”. It means that setting is done when the green LED become dimmed.

4. Clear Customized Button:

- (1)** Hold SHARE and OPTIONS buttons for 3 seconds, and the green LED would be lit.
- (2)** Firstly, press one of “Buttons for Replacement”; then the green LED starts blinking.
- (3)** Press one of “Customizable Buttons”. It means that setting is restored when the green LED become dimmed.

5. Clear All Customized Buttons:

- (1)** Hold SHARE and OPTIONS buttons for 3 seconds, and the green LED would be lit.
- (2)** Hold OPTIONS button for 4 seconds. It means that all customized buttons are restored when the green LED become dimmed.



Unplug a racing wheel from game consoles or PC also do a job for reverting all customized buttons to their default settings.

6. Set Pedals to Work as Y Axis: (For controlling flight altitude for aircrafts)
 - (1) Hold SHARE and OPTIONS buttons for 3 seconds, and the green LED would be lit.
 - (2) Press LEFT arrow key. It means that setting is done when the green LED become dimmed.
7. Set Paddle Shifters to Work as Y Axis: (For controlling flight altitude for aircrafts)
 - (1) Hold SHARE and OPTIONS buttons for 3 seconds, and the green LED would be lit.
 - (2) Press RIGHT arrow key. It means that setting is done when the green LED become dimmed.

8. Adjust Steering Sensitivity:

- (1)** Hold SHARE and OPTIONS buttons for 3 seconds, and the green LED would be lit.
- (2)** Press SHARE button again; the LED would blink in different ways according to different settings of steering sensitivity, as follows:
 - a. Fast blinking: Aggressive
 - b. Normal: blinking: Moderate
 - c. Slow blinking: Unaggressive
- (3)** Press SHARE button for multiple times in order to sequentially adjust steering sensitivity.
- (4)** Lastly, press UP arrow key. It means that setting is done when the green LED become dimmed.

For Serafim R1:

1. Customizable Buttons: Action keys (A/3, B/2, Y/1, X/4), LB/5, RB/6, LT/7, RT/8

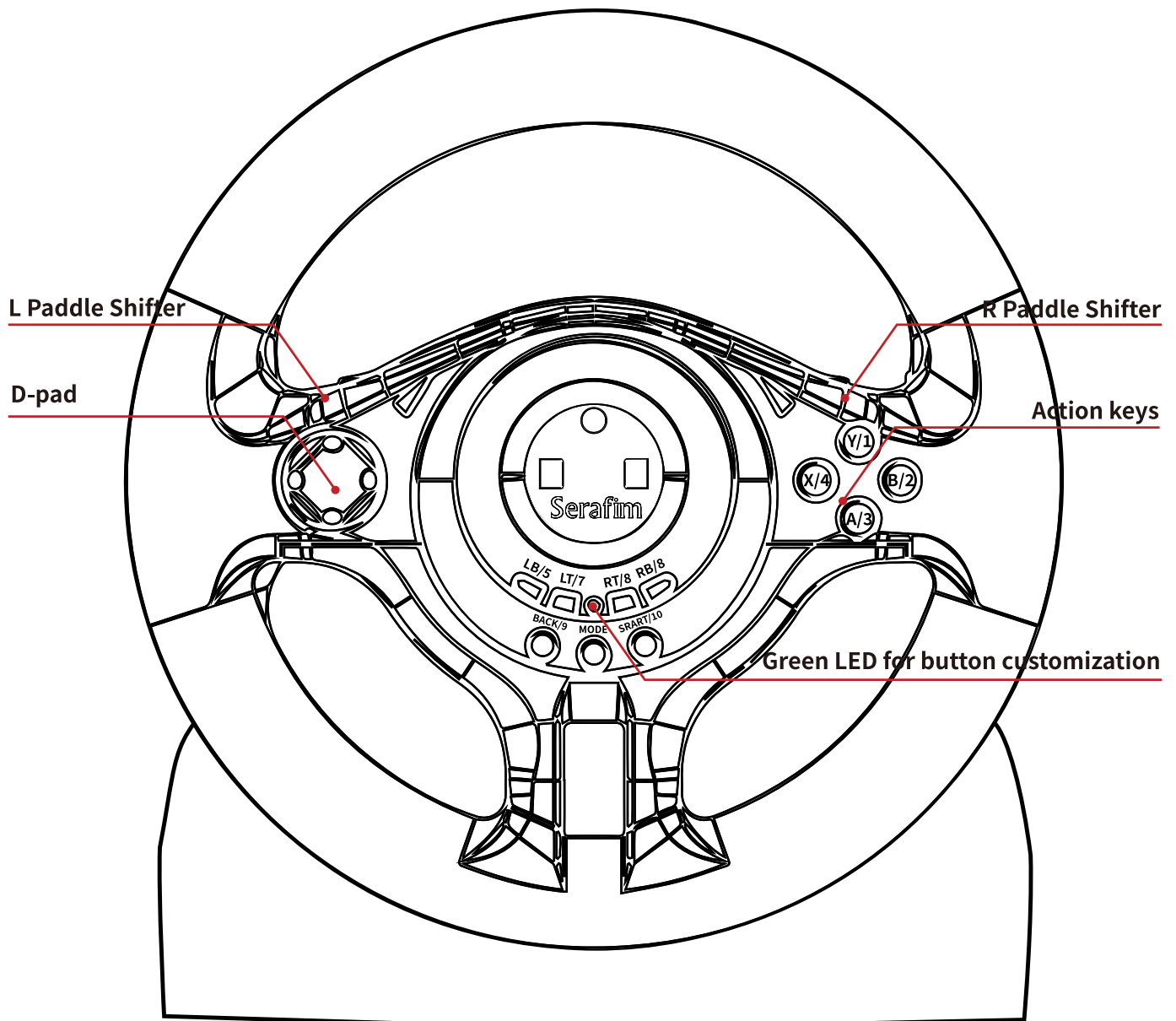

2. Buttons for Replacement: L/R paddle shifter, Gas pedal, Brake pedal.

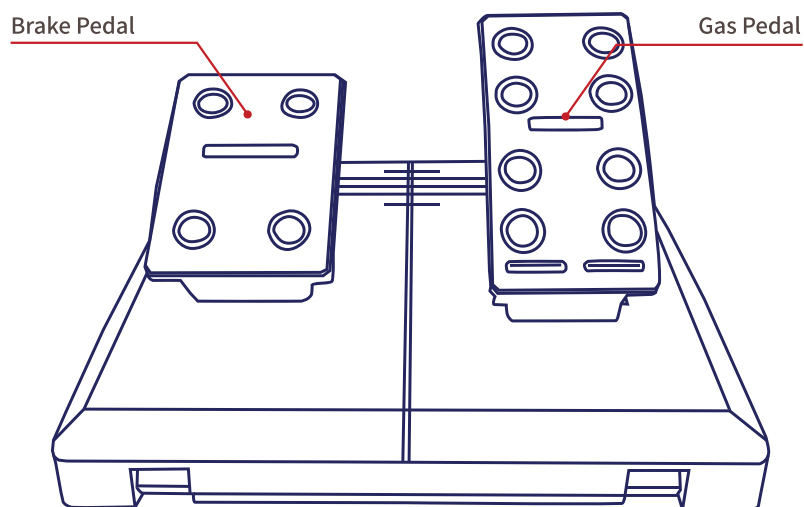
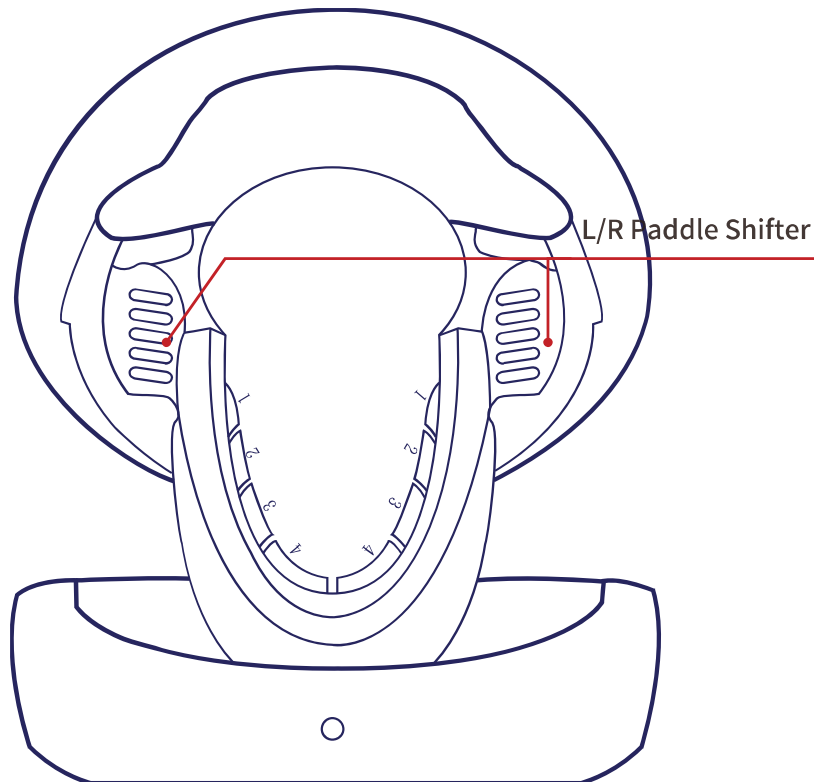

3. Procedures for Customizing Buttons:

- (1)** Hold BACK and START buttons for 3 seconds, and the green LED would be lit.
- (2)** Firstly, press one of “Buttons for Replacement”; then the green LED starts blinking.
- (3)** Press one of “Customizable Buttons”. It means that setting is done when the green LED become dimmed.

4. Clear All Customized Buttons:

- (1)** Hold BACK and START buttons for 3 seconds, and the green LED would be lit.
- (2)** Hold START button for 4 seconds. It means that all customized buttons are restored when the green LED become dimmed.

5. Adjust Steering Sensitivity:

- (1)** Hold BACK and START buttons for 3 seconds, and the green LED would be lit.
- (2)** Press BACK button again; the LED would blink in different ways according to different settings of steering sensitivity, as follows:
 - a. Fast blinking: Aggressive
 - b. Normal: blinking: Moderate
 - c. Slow blinking: Unaggressive
- (3)** Press BACK button for multiple times in order to sequentially adjust steering sensitivity.
- (4)** Lastly, press UP arrow key. It means that setting is done when the green LED become dimmed.

R1+: How to Play on Consoles

1. For PS4

- (1)** Connect racing wheel to PS4 console; plug foot pedals into the racing wheel. Turn on the power of PS4.
- (2)** Plug PS4 controller to the back of racing wheel.
- (3)** Red LED would be lit if the wheel is connected. Press HOME button. Done!

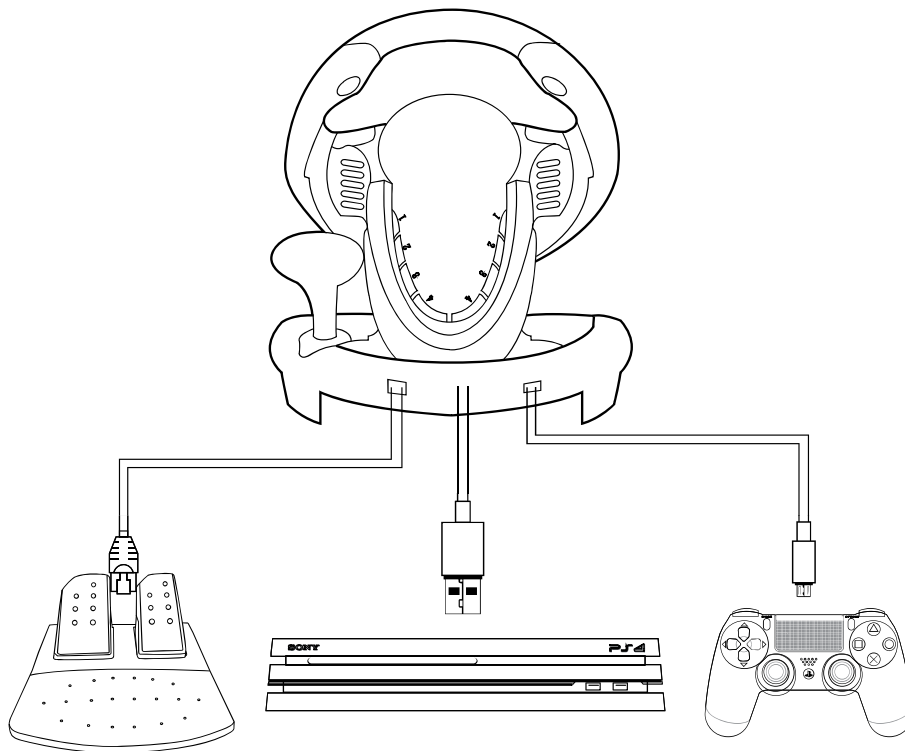

2. For PS3

- (1)** Connect racing wheel to PS3 console; plug foot pedals into the racing wheel. Turn on the power of PS3.
- (2)** The channel light at the back of wheel would be lit if the wheel is connected.
- (3)** Press HOME button. Done!

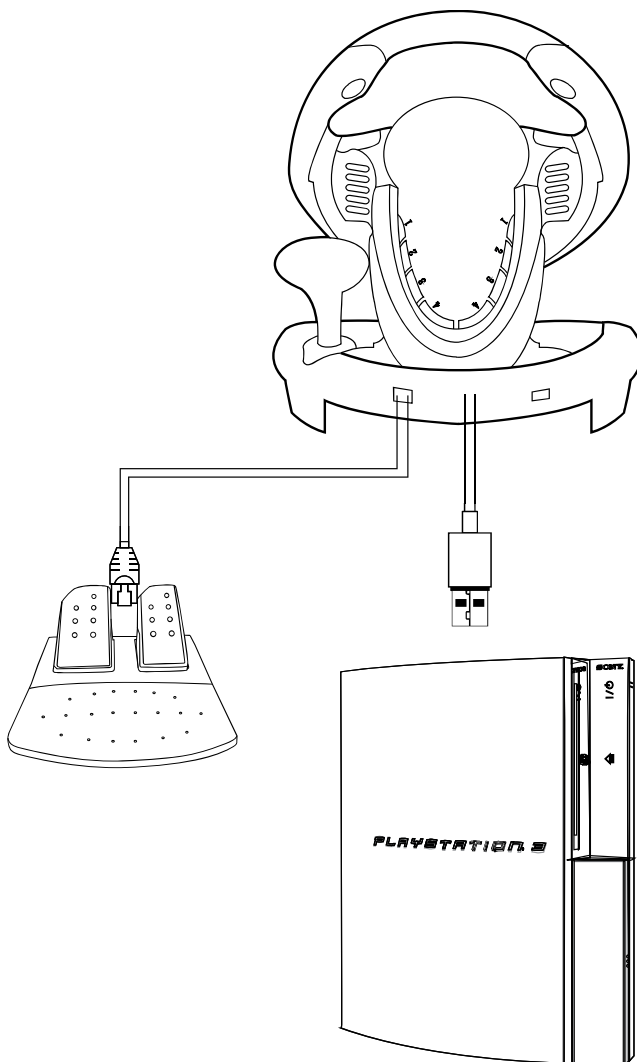

3. For Xbox One

- (1)** Connect racing wheel to Xbox One console; plug foot pedals into the racing wheel. Turn on the power of Xbox One.
- (2)** Plug Xbox One controller to the back of racing wheel.
- (3)** Red LED would be lit if the wheel is connected. Press HOME button. Done!

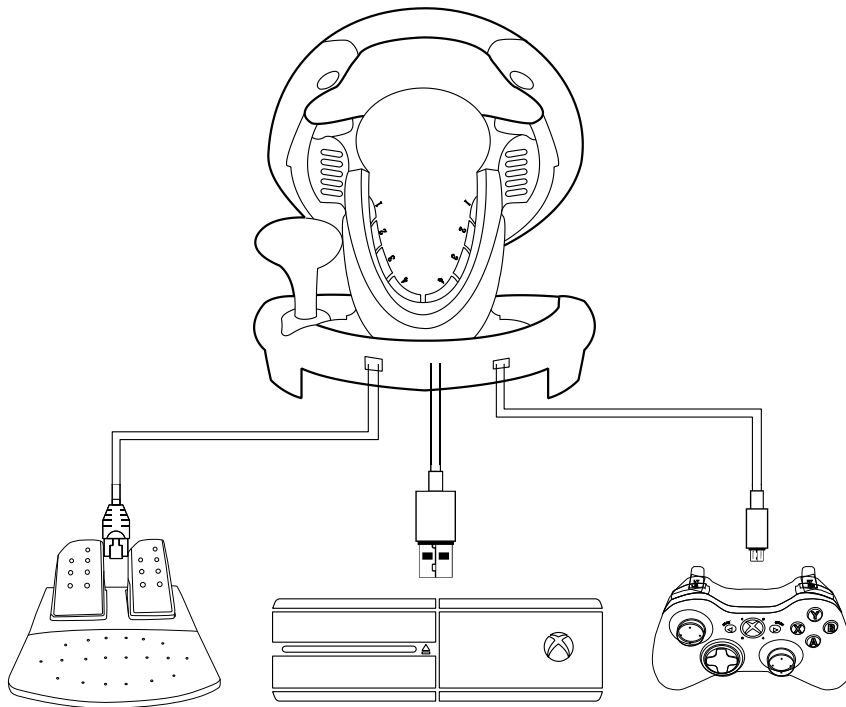

4. For Switch

- (1)** Connect racing wheel to Switch console; plug foot pedals into the racing wheel. Turn on the power of Switch.
- (2)** System→Controllers and Sensors→Select “Pro Controller Wired Communication”
- (3)** Red LED and channel light at the back of wheel would be lit if the wheel is connected.

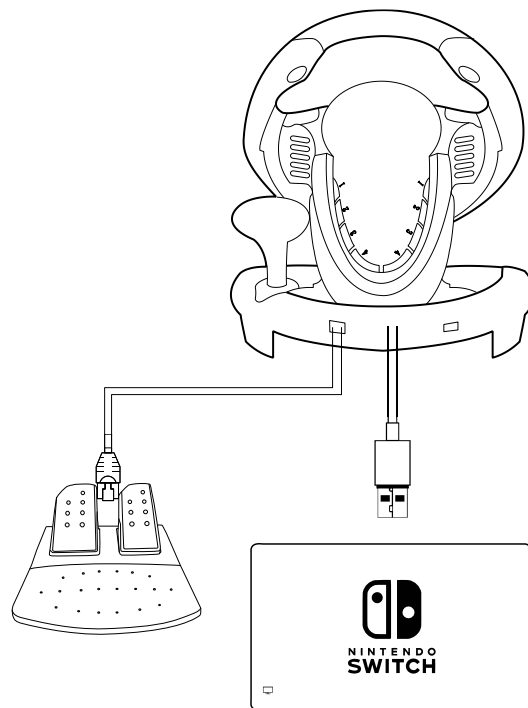

R1/R1+: How to Play on PC

1. X-input Mode

- (1)** Connect racing wheel to a PC. The default mode is X-input. When the wheel is connected, the red LED would be lit, and the channel light at the back of wheel would be lit.
- (2)** Hold HOME button for 3 seconds, you could sequentially switch between X-input and D-input mode. The red LED would flick 6 times while switching modes. The channel light at the back of the wheel would dim after a switch.

2. D-input Mode

- (1)** Connect racing wheel to a PC.
- (2)** For D-input mode, it is needed to install drivers to make it work. Drivers are compatible with Windows Vista, 7, 8, and 10 for now.
- (3)** Insert a driver installation disc or download it on our official website and follow instructions of installation wizard.

<http://www.serafim-tech.com/serafim-r1/serafim-r1-d-input-driver-en.html>

3. Benchmark and Calibration

- (1)** Connect racing wheel to a PC.
- (2)** Start button→Control Panel→Devices and Printers→Right-click the wheel icon→Controller Properties
- (3)** In “Function Test” tab, you could test functionality of buttons, and axes here.
- (4)** In “Calibration Function” tab, you could calibrate wheel steering (Left Axis) and foot pedals (Right Axis).
- (5)** In “Vibration Test” tab, you could adjust or test vibration of the wheel.

Product Specification

1. Technical Specification of Serafim R1+:

Wheel	270 (H) x 260 (W) x 278 (D) mm
Pedals	135 (H) x 220 (W) x 235 (D) mm
Weight	2,600 g
Support	iOS / Android / PC / PS3 /PS4 / Xbox One/ Switch
Bluetooth 4.0	Supported
USB	Supported
Vibration Feedback	PC / PS3 / PS4 / Xbox One / Switch
In the Box	Racing wheel, Racing pedals, USB cable, Bluetooth module

2. Technical Specification of Serafim R1:

Wheel	250 (H) x 220 (W) x 260 (D) mm
Pedals	160 (H) x 180 (W) x 190 (D) mm
Weight	1,900 g
Support	iOS / Android / PC
Bluetooth 4.0	<input type="radio"/>
USB	<input type="radio"/>
Vibration Feedback	PC
In the Box	Racing wheel, Racing pedals, USB cable, Bluetooth module

3. Battery and Environmental Condition:

Type of dry cells	AAA x3 pcs
Duration for Bluetooth connection	About 200 hours
Operating temperature	0° ~ 35° C
Storage temperature	-20° ~ 45° C
Relative humidity	5% ~ 95%, noncondensing

Key Mapping

1. Button bindings for Serafim R1+:

	PS3	PS4	Xbox One	PC (X-INPUT)	PC (D-INPUT)	Switch
Action	×	×	A	A	2	B
	○	○	B	B	3	A
	□	□	X	X	1	Y
	△	△	Y	Y	4	X
	R1	R1	RB	RB	6	R
	L1	L1	LB	LB	5	L
	R2	R2	RT	RT	8	ZR
	L2	L2	LT	LT	7	ZL
	R3	R3	SR	SR	12	R3
	L3	L3	SL	SL	11	L3
D-pad	UP	UP	UP	UP	UP	UP
	DOWN	DOWN	DOWN	DOWN	DOWN	DOWN
	LEFT	LEFT	LEFT	LEFT	LEFT	LEFT
	RIGHT	RIGHT	RIGHT	RIGHT	RIGHT	RIGHT
Function	START	OPTIONS	Menu	START	10	+
	SELECT	SHARE	View	BACK	9	-
Direction	LX	LX	← / →	← / →	← / →	LX
Left side	□	L2	LT	LT	1	B
Right side	×	R2	RT	RT	2	Y
Change gear	L2	L1	LB	LB	7	ZL
	R2	R1	RB	RB	8	ZR
Left pedal	□	L2	LT	LT	1	B
Right pedal	×	R2	RT	RT	2	Y
Mode	HOME	HOME	X-	X-	13	HOME

2. Button bindings for Serafim R1:

	PC (X-INPUT)	PC (D-INPUT)
Action	A	3
	B	2
	X	4
	Y	1
	RB	6
	LB	5
	RT	8
	LT	7
D-pad	UP	UP
	DOWN	DOWN
	LEFT	LEFT
	RIGHT	RIGHT
Function	START	10
	BACK	9
	← / →	← / →
Left side	LB	5
Right side	RB	6
Left Pedal	LT	Y-
Right Pedal	RT	Y+
Mode	X-Guide	MODE

Safety Notes

1. Please avoid using under direct sun and heat sources
2. Notice the risk of malfunction if used in an environment with drastic temperature change, high humidity or high-pressure environment
3. Excessive force or impact on the product may cause damage to the product and void the warranty.
4. Never attempt to disassemble, modify and or repair the product by yourself.
5. Please keep the “Serafim Play” running in the background while playing racing games.

6. The stability of suction cups may vary from table surface to another. We also offer a table mounting clamp for better stability.
7. A table mounting clamp can hold a table with 3.5 cm in thickness.
8. 95% of Android phones support Serafim R1+. However, some phones, which don't meet minimum requirement, are not compatible with the racing wheels.

9. Unsupported Android devices:

- A phone with MTK CPU
- Asus Zenphone 5
- Asus ROG Phone 2
- Sony Xperia XA2
- Oppo A83/A77
- Vivo V11/V11i

10. We recommend connecting a controller with sufficient battery charge level while playing games with a wheel on a game console.

Troubleshooting

Q1. The wheel has no response while pressing buttons on it for consoles.

1.The red LED on the wheel would be lit when connected.

2.Try to rotate or pressing buttons on the wheel.

* If there is still no response, please change a USB cable which is connected to your wheel.

3.Go to in-game settings, change steering option to “left stick”.

* For using an extension cord, the total length of it should be **less than 3 meters**.

For the length that is over 3 meters, please use an USB hub with an AC adaptor to connect a wheel.

Q2. Pedal shifters won't work on PC and consoles.

1. Please revert in-game button assignment settings to their default values and adopt customized buttons to get paddle shifters work properly.

2. Default key bindings are as follows:

- RT/R2=R paddle shifter=Right pedal,
- LT/L2=L paddle shifter=Left pedal,
- RB/R1=Push gear stick forward,
- LB/L1=Pull gear stick back.

* Take Gran Turismo Sport as an example.

Let's say × is button for "Shift up". The following is the way to assign this button to the right paddle shifter.

1. Firstly, press both SHARE and OPTIONS buttons for 3 seconds, the green indicator on the right would be lit.

2. Press the right paddle shifter, and the indicator would start blinking.

3. Lastly, press × button, and the indicator would be dimmed. Done!

Q3. Unable to use the wheel on a PC game

1. Go to control settings in the game

2. Select **controller or Xbox 360 controller** to get the wheel to work properly

Q4. The wheel becomes not functioning while getting into a game on Switch.

A For single player racing game, a Joy-Con may get an exclusive access to the Switch console. In order to regain the exclusive access to the Switch console,

1. firstly, please put your Joy-Con back into the Switch dock and

2. restart the console.

3. Navigate the main menu and launch the

racing game **with the wheel**.

Q5. Pedals work weird while playing racing games on a phone

- 1.** Firstly, turn off the power of Bluetooth module. Switch to iOS or Android mode that fits your phone.
- 2.** Go to Settings on your phone, delete the paired Bluetooth device, Serafim R1.
- 3.** Turn on the power of Bluetooth module again, and pair it with your phone.

Q6. My TV screen starts blinking or becoming a dark screen when connect the wheel to a console

A The interference may occur while charging a controller in low battery level with a wheel. In order to solve this, please fully charge your controller and try again.

Q7. The in-game steering wheel will not automatically turn back by itself while I am driving a truck.

A For steering wheel of a truck, it mostly can be rotated over 720 degrees. However, for Serafim R1/R1+, it can be rotated 180 degrees only. In this case, it is normal that the in-game steering wheel doesn't synchronize with the actual one.



FCC Wireless Equipment

This device complies with Part 15 of the FCC Rules. Operation is subject to the following two conditions:

- (1)** this device may not cause harmful interference, and
- (2)** this device must accept any interference received, including interference that may cause undesired operation.

This equipment complies with FCC radiation exposure limits set forth for an uncontrolled environment. This equipment should be installed and operated with a minimum distance of 20cm between the radiator & your body. This transmitter must not be co-located or operating in conjunction with any other antenna or transmitter.

FCC Class B Equipment

Note: This equipment has been tested and found to comply with the limits for a Class B digital device, pursuant to Part 15 of the FCC Rules. These limits are designed to provide reasonable protection against harmful interference in a residential installation. This equipment generates, uses, and can radiate radio frequency energy, and if not installed and used in accordance with the instructions, may cause harmful interference to radio communications.

However, there is no guarantee that interference will not occur in a particular installation. If this equipment does cause harmful interference to radio or television reception, which can be determined by turning the equipment off and on, the user is encouraged to try to correct the interference by one or more of the following measures:

- Reorient or relocate the receiving antenna.
- Increase the separation between the equipment and receiver.
- Connect the equipment into an outlet on a circuit different from that to which the receiver is connected.
- Consult the dealer or an experienced radio/TV technician for help.

CE Caution



RISK OF EXPLOSION IF BATTERY IS REPLACED BY AN INCORRECT TYPE. DISPOSE OF USED BATTERIES ACCORDING TO THE INSTRUCTIONS.

NCC 使用警語

依據低功率電波輻射性電機管理辦法

第十二條

經型式認證合格之低功率射頻電機，非經許可，公司、商號或使用者均不得擅自變更頻率、加大功率或變更原設計之特性及功能。

第十四條

低功率射頻電機之使用不得影響飛航安全及干擾合法通信；經發現有干擾現象時，應立即停用，並改善至無干擾時方得繼續使用。

前項合法通信，指依電信法規定作業之無線電通信。低功率射頻電機須忍受合法通信或工業、科學及醫療用電波輻射性電機設備之干擾。

*減少電磁波影響，請妥善使用

KCC 경고 사용

"이 장치는 보안성이 없으므로 통신보안에
위배되는 사항의 통신을 금지하며 운용 중
기기상호간 혼신 가능성이 있음" 및
"생활무선국"