

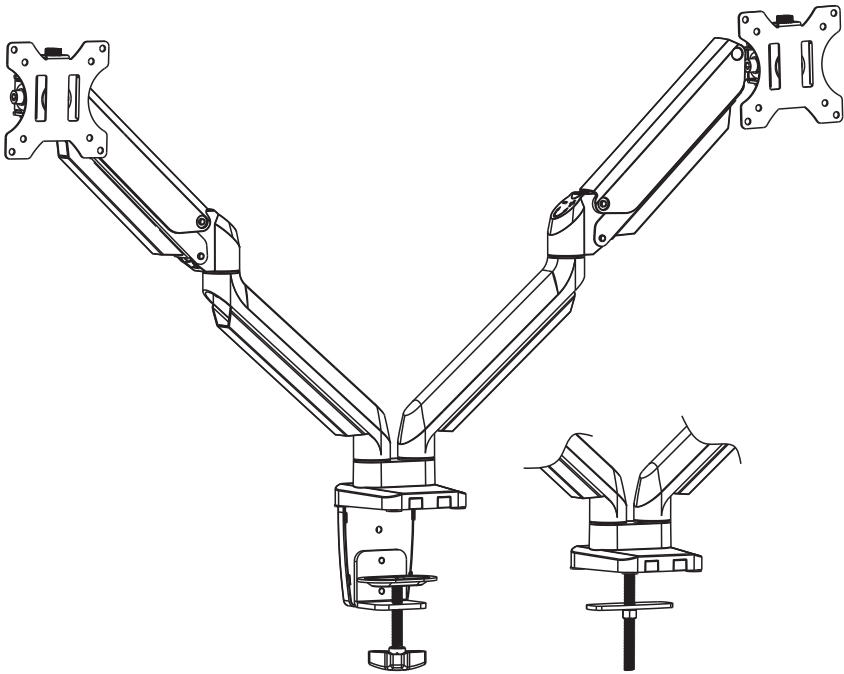

INSTALLATION MANUAL

# Counterbalance Monitor Desk Arm



**ELTGM05-2**



75x75/100x100



(1.5~8kg)x2  
(3.3~17.6lbs)x2  
RATED



[EleTab\\_service@outlook.com](mailto:EleTab_service@outlook.com)



[www.facebook.com/EleTabus](http://www.facebook.com/EleTabus)

 Read the entire instruction manual before you start installation and assembly. If you have any questions regarding any of the instructions or warnings, Please contact at EleTab\_service@outlook.com for assistance.

## CAUTION:

 Use with products heavier than the rated weights indicated may result in instability causing possible injury.

- Mounts must be attached as specified in assembly instructions. Improper installation may result in damage or serious personal injury.
- Safety gear and proper tools must be used. This product should only be installed by professionals.
- Make sure that the supporting surface will safely support the combined weight of the equipment and all attached hardware and components.
- Use the mounting screws provided and DO NOT OVER TIGHTEN mounting screws.
- This product contains small items that could be a choking hazard if swallowed. Keep these items away from children.
- This product is intended for indoor use only. Using this product outdoors could lead to product failure and personal injury.

## IMPORTANT:

Ensure that you have received all parts according to the component checklist prior to installation. If any parts are received damaged or defective, please contact us at EleTab\_service@outlook.com. We are happy to replace parts to ensure you have a fully functioning product.

## PRODUCT LINE GRAPH

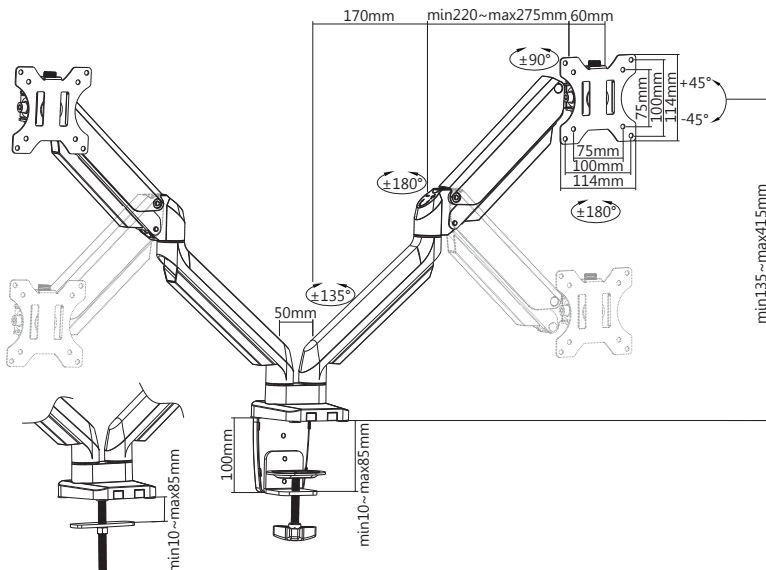

# Parts

## Tools required



**O (x1)**  
4mm Allen  
Wrench



**P (x1)**  
6mm Allen  
Wrench



**Q (x1)**  
Wrench



Phillips  
Screwdriver  
(not included)

## Components

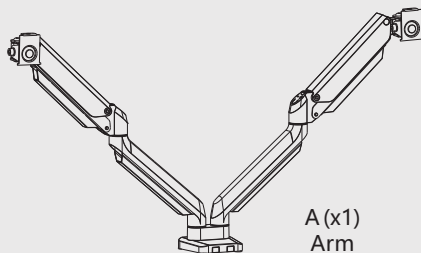

**A (x1)**  
Arm



**B (x2)**  
VESA Plate



**C (x1)**  
Clamp Base  
Support



**D (x1)**  
Clamp



**E (x1)**  
Cable Clip



**F (x1)**  
Long Screw



**G (x1)**  
Base Support



**H (x1)**  
Support Plate



**I (x1)**  
Nut



**J (x1)**  
Washer



**K (x2)**  
Security Nut



**L (x2)**  
Bolts



**M (x3)**  
Bolts



**N (x4)**  
Pad

## Hardware



**M4x12mm (x4)**  
M-A  
Screws



**M4x16mm (x4)**  
M-B  
Screws



**M5x12mm (x4)**  
M-C  
Screws



**M5x16mm (x4)**  
M-D  
Screws



**D5 (x4)**  
M-E  
Washer



**M-F (x4)**  
M-F  
Washer

# X2

# STEP 1 Choose a mounting option

## OPTION A: Clamp Installation

Install clamp base support (C) onto base of monitor stand (A) with bolts (M) using provided 4mm Allen wrench (O).

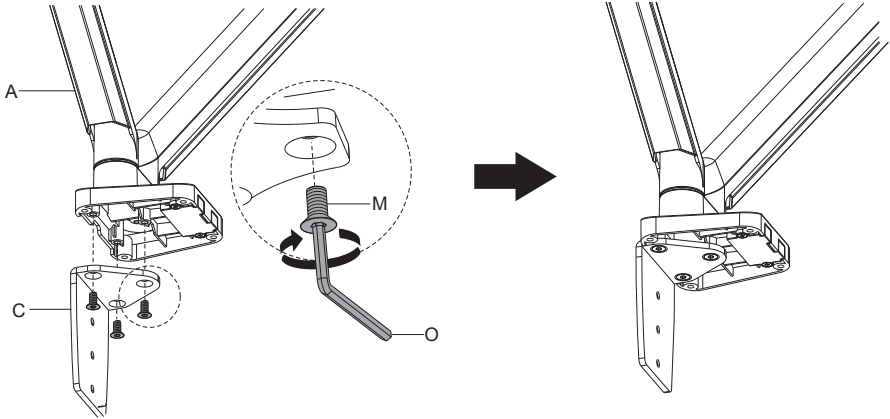

Apply pads (N) to bottom of base to prevent table top from being scratched.

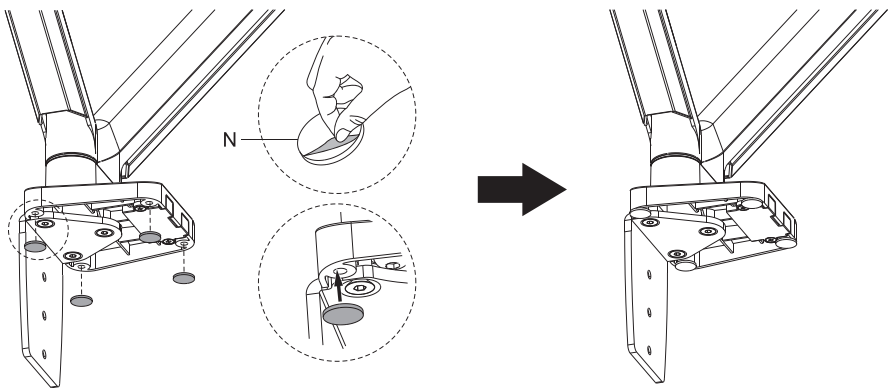

Secure clamp (D) to upper two holes with bolts (L) using 4mm Allen wrench (O) for desks with a thickness of 10-55mm.

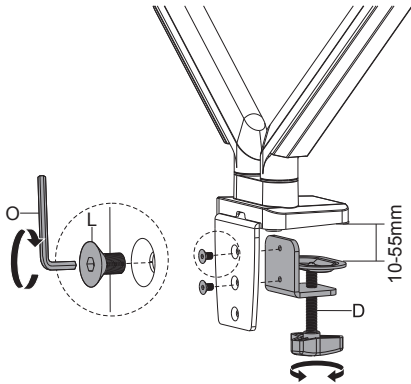

Secure clamp (D) to lower two holes with bolts (L) using 4mm Allen wrench (O) for desks with a thickness of 50-85mm.

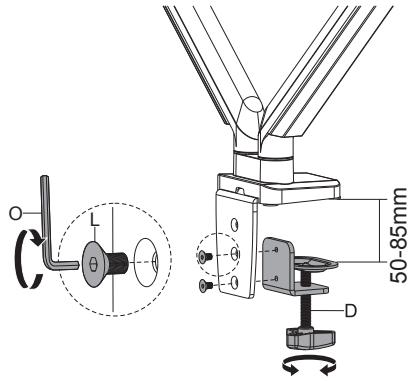

Attach base support cover (E) to clamp base support (C). Tighten the clamp to the desktop using the plastic knob.

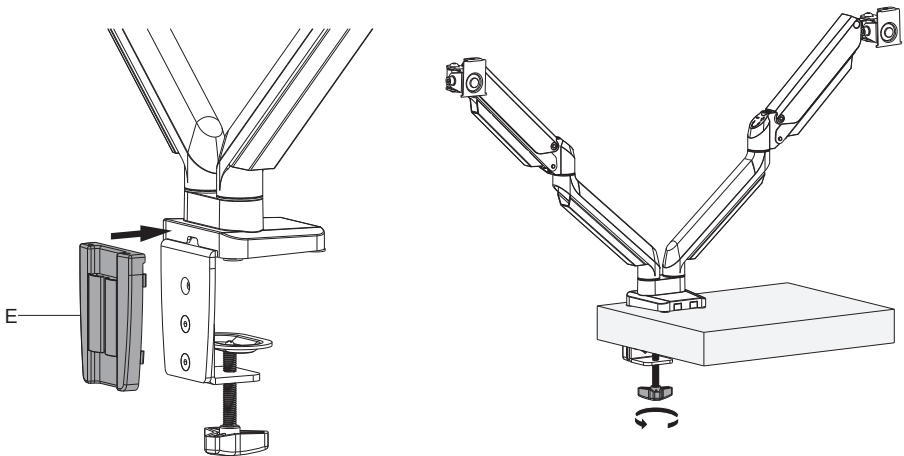

# STEP 1 (Continued)

## OPTION B: Grommet Base Installation

Slide long screw (F) through the top of the grommet base support (G) and install on base of monitor stand with bolts (M) using 4mm Allen wrench (O). Apply pads (N) to bottom of base.

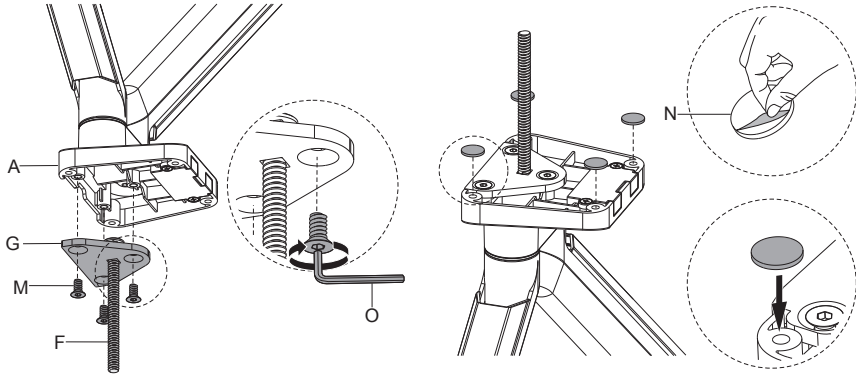

Position stand on desk with long screw through hole, and secure by using the support plate (H) and washer (J) on underside of the mounting surface, tighten the nut (I) with wrench (Q).

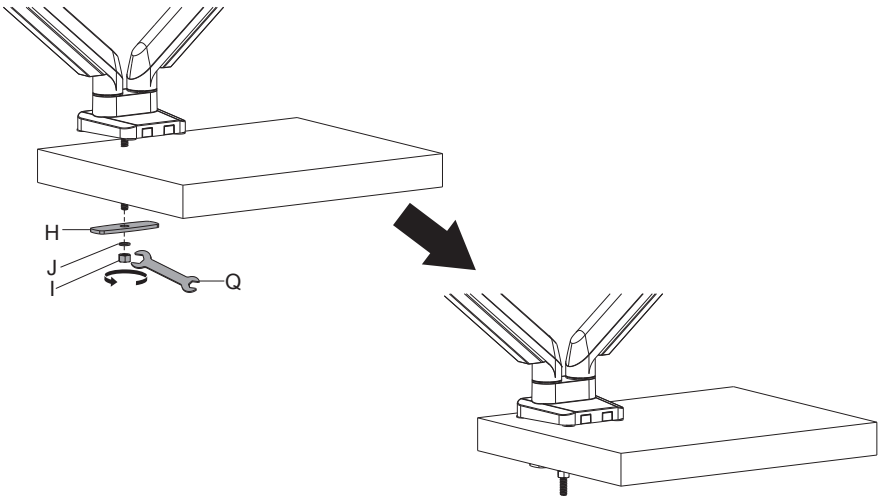

# STEP 2 Attach the monitors to the arm

## OPTION A: Flat Back Monitor

Attach the VESA plate (B) to back of monitor and secure with screws (M-A) or (M-C) with washers (M-E). Avoid excessive tightening screws damage the monitor.

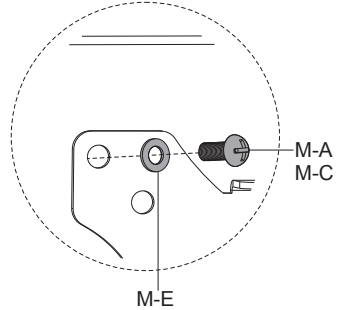
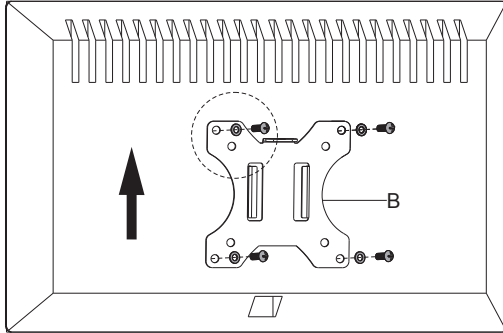

## OPTION B: Curved Back Monitor

Attach the VESA plate (B) to back of monitor and secure with screws (M-B) or (M-D) with washers (M-E) and washers (M-F). Avoid excessive tightening screws damage the monitor.

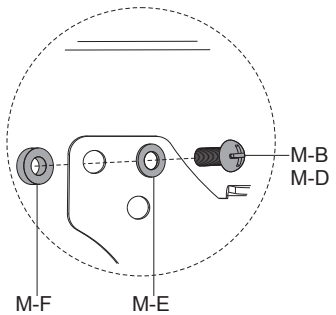
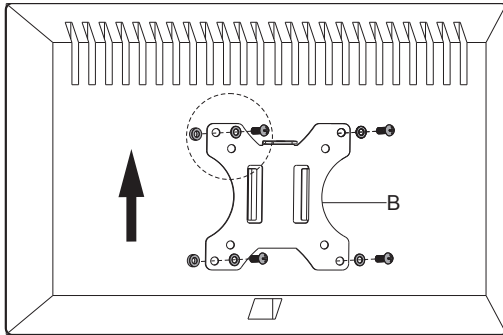

Slide the monitor onto the head of swivel arm, install the security nut (K). Make sure the security nut is installed before you rotate the monitor.

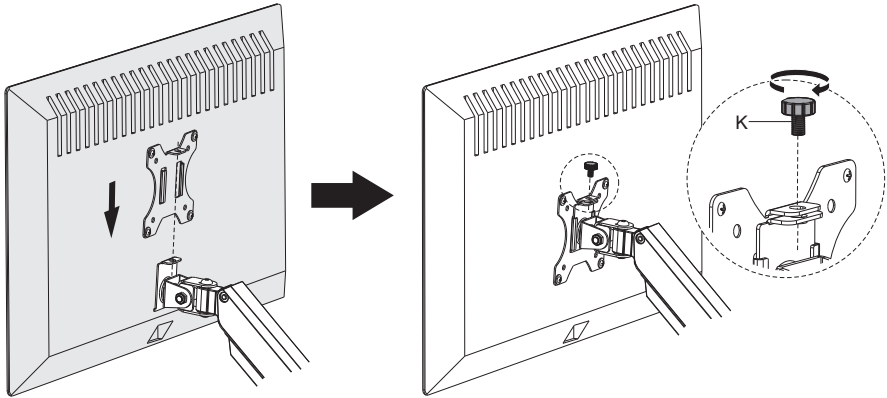

## STEP 3 Adjust the tension

Adjust gas spring tension by turning screw with 6mm Allen wrench (P). Clockwise(" - " direction) reduces tension, counter Clockwise(" + " direction) increases tension. The tension should be just enough to hold your monitor in place without lifting itself up.

Be sure to keep the arm in horizontal position during adjustment .Or else it would be difficult to adjust the mount or damage the mount.

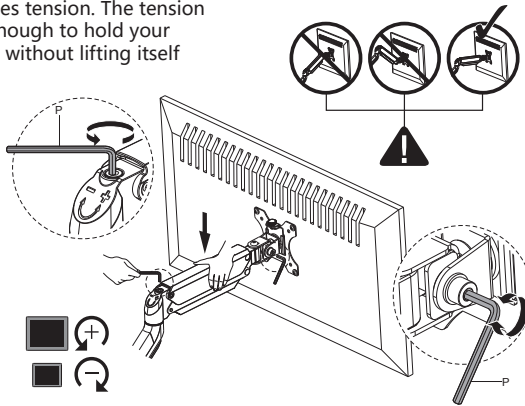

If needed, adjust the bolt on the side of the hinge behind the VESA plate to tighten or loosen the tilt angle support.

## STEP 4 Cable Management

For both bottom and upper portion of the spring arm, just slide the cable cover up and away from the spring arm, do not need to take much effort to pull the ends of the cable cover away from the spring arm.

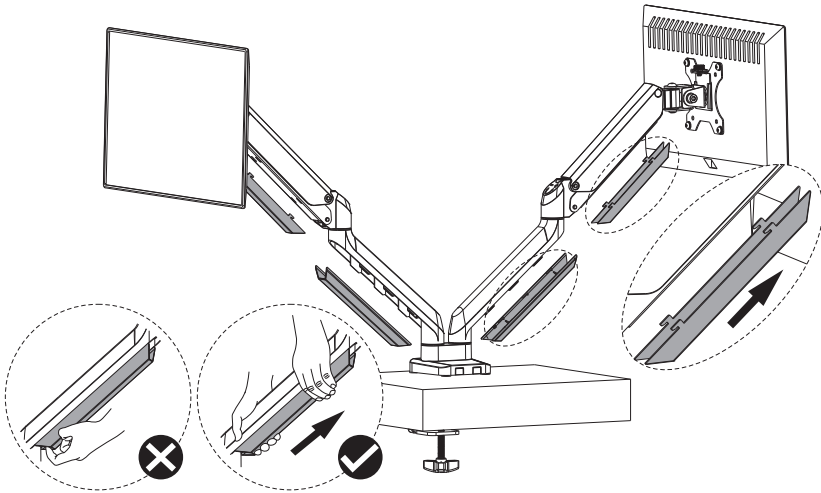

On the bottom portion of the spring arm, insert the cable and slide the cable cover down; On the upper portion of the spring arm, press the tabs on the inside of the cable cover slightly inward and slide down to reattach the cable cover.

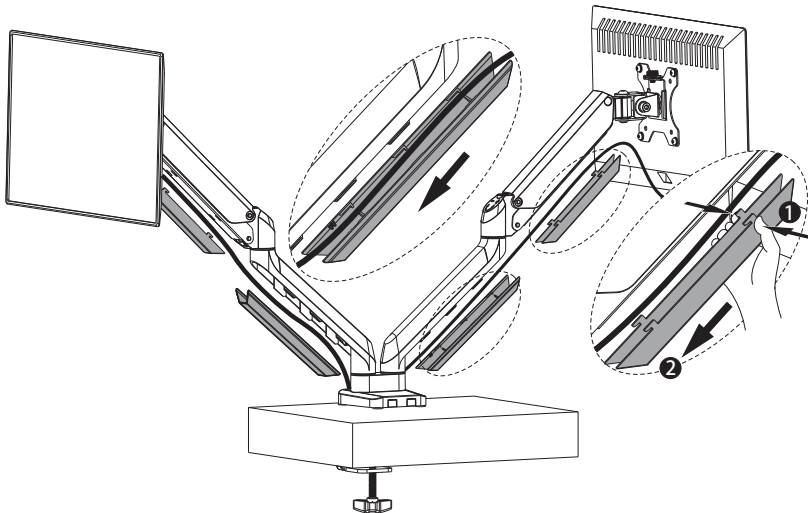

# WARRANTY SERVICE

To provide the best service to you, do not forget to register your EleTab product to confirm your warranty.

It only takes a few simple steps and then you can access a wide-range of services such as technical support, new products alert, promotions, and warranty service from EleTab.



Send your name and order ID to [EleTab\\_service@outlook.com](mailto:EleTab_service@outlook.com)

---

## Feedback

### Love it? Hate it?

Let us know with a customer review.

EleTab is committed to delivering customer-driven products that live up to you high standards. We encourage you to write a review sharing your experience.

Should you have any issues, please don't hesitate to contact us.

---



Scan the qr code below for more products from EleTab

For further services:



[EleTab\\_service@outlook.com](mailto:EleTab_service@outlook.com)



[www.facebook.com/EleTabus](http://www.facebook.com/EleTabus)