

CHAMPION

GLOBAL POWER EQUIPMENT

TM-MC

OWNER'S MANUAL



4000 Starting watts / 3500 Running watts DIGITAL HYBRID PORTABLE GENERATOR



MODEL NUMBER

100302

SAVE THESE INSTRUCTIONS
Important safety instructions
are included in this manual.

MADE IN CHINA
REV 100302-20171205

12039 Smith Ave.
Santa Fe Springs CA 90670 USA
1-877-338-0999
www.championpowerequipment.com

FCC Statement

1. This device complies with Part 15 of the FCC Rules. Operation is subject to the following two conditions:
 - (1) This device may not cause harmful interference.
 - (2) This device must accept any interference received, including interference that may cause undesired operation.
2. Changes or modifications not expressly approved by the party responsible for compliance could void the user's authority to operate the equipment.

NOTE: This equipment has been tested and found to comply with the limits for a Class B digital device, pursuant to Part 15 of the FCC Rules. These limits are designed to provide reasonable protection against harmful interference in a residential installation. This equipment generates uses and can radiate radio frequency energy and, if not installed and used in

accordance with the instructions, may cause harmful interference to radio communications. However, there is no guarantee that interference will not occur in a particular installation. If this equipment does cause harmful interference to radio or television reception, which can be determined by turning the equipment off and on, the user is encouraged to try to correct the interference by one or more of the following measures:

- Reorient or relocate the receiving antenna.
- Increase the separation between the equipment and receiver.
- Connect the equipment into an outlet on a circuit different from that to which the receiver is connected.

Consult the dealer or an experienced radio/TV technician for help.

Have questions or need assistance?

Do not return this product to the store!

WE ARE HERE TO HELP!

Visit our website:

www.championpowerequipment.com

for more info:

- Product Info & Updates
- Tech Bulletins
- Frequently Asked Questions
- Product Registration

– or –

Call our Customer Care Team Toll-Free at:

1-877-338-0999

Parts Ordering:

Mon – Fri 8:30 AM – 5:00 PM (PST/PDT)

Toll Free: 1-877-338-0999

For residents of California:

WARNING: This product contains chemicals known to the State of California to cause cancer or birth defects and other reproductive harm.

WARNING: The engine exhaust from this product contains chemicals known to the State of California to cause cancer and birth defects and other reproductive harm.

*We are always working to improve our products. Therefore, the enclosed product may differ slightly from the image on the cover.

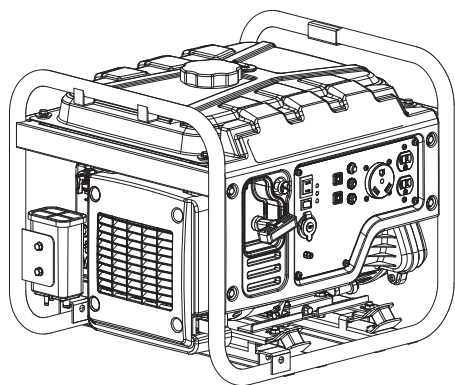

4000 Starting Watts / 3500 Running Watts DIGITAL HYBRID PORTABLE GENERATOR

TABLE OF CONTENTS

Introduction	1	Maintenance and Storage	16
Manual Conventions	2	Engine Maintenance	16
Safety Rules	3	Oil	16
Safety Label Locations	5	Spark Plugs	16
Controls and Features	6	Air Filter	16
Generator	6	Spark Arrester	17
Power Panel	7	Adjustments	17
Power Panel Symbols	8	Maintenance Schedule	17
Parts Included	8	Generator Maintenance	18
Assembly	9	Cleaning	18
Unboxing	9	Storage	18
Add Engine Oil	9	Short Term Storage	18
Add Fuel	10	Long Term Storage	18
Grounding	11	Removing from Storage	19
Operation	12	Specifications	20
Generator Location	12	Engine Specifications	20
Grounding	12	Generator Specifications	20
Starting the Engine	12	Fuel	20
Economy Control Switch	13	Oil	20
Connecting Electrical Loads	13	Spark Plugs	20
12V DC Outlet	14	Maintenance Valve Clearance	20
Stopping the Engine	14	An Important Message About Temperature	20
Do Not Overload Generator	14	Parts Diagram	21
Capacity	14	Parts List	22
Power Management	14	Engine Parts Diagram	23
Overload Operation	15	Engine Parts List	24
Parallel Operation	15	Wiring Diagram	25
Operation at High Altitude	15	Troubleshooting	26

INTRODUCTION

Congratulations on your purchase of a Champion Power Equipment product. Champion Power Equipment and Champion Engine Technology designs, builds, and supports all of our products to strict specifications and guidelines. With proper product knowledge, safe use, and regular maintenance, this product should bring years of satisfying service.

Every effort has been made to ensure the accuracy and completeness of the information in this manual, and we reserve the right to change, alter and/or improve the product and this document at any time without prior notice.

Since CPE/CET highly value how our products are designed, manufactured, operated and are serviced, and also highly value your safety and the safety of others, we would like you to take the time to review this product manual and other product materials thoroughly and be fully aware and knowledgeable of the assembly, operation, dangers and maintenance of the product before use. Fully familiarize yourself, and make sure others who plan on operating the product fully familiarize themselves too, with the proper safety and operation procedures before each use. Please always exercise common sense and always err on the side of caution when operating the product to ensure no accidents, property damage, or injury occurs. We want you to continue to use and be satisfied with your CPE/CET product for years to come.

Record the model and serial numbers as well as date and place of purchase for future reference. Have this information available when ordering parts and when making technical or warranty inquiries.

Champion Power Equipment Support	
1-877-338-0999	
Model Number	
100302	
Serial Number	
Date of Purchase	
Purchase Location	
For Oil Type see 'Add Engine Oil' section. For Fuel Type see 'Add Fuel' section.	

This manual uses the following symbols to help differentiate between different kinds of information. The safety symbol is used with a key word to alert you to potential hazards in operating and owning power equipment.

Follow all safety messages to avoid or reduce the risk of serious injury or death.

 **DANGER**

DANGER indicates an imminently hazardous situation which, if not avoided, **will** result in death or serious injury.

 **WARNING**

WARNING indicates a potentially hazardous situation which, if not avoided, **could** result in death or serious injury.

 **CAUTION**

CAUTION indicates a potentially hazardous situation which, if not avoided, **may** result in minor or moderate injury.

CAUTION

CAUTION used without the safety alert symbol indicates a potentially hazardous situation which, if not avoided, **may** result in property damage.

 **NOTE**

If you have questions regarding your generator, we can help. Please call our help line at **1-877-338-0999**

SAFETY RULES

WARNING

Read this manual thoroughly before operating your generator. Failure to follow instructions could result in serious injury or death.

WARNING

The engine exhaust from this product contains chemicals known to the state of California to cause cancer, birth defects, or other reproductive harm.

DANGER

Generator exhaust contains carbon monoxide, a colourless, odourless, poison gas. Breathing carbon monoxide will cause nausea, dizziness, fainting or death. If you start to feel dizzy or weak, get to fresh air immediately.

Operate generator outdoors only in a well ventilated area.

DO NOT operate the generator inside any building, including garages, basements, crawlspaces and sheds, enclosure or compartment, including the generator compartment of a recreational vehicle. DO NOT allow exhaust fumes to enter a confined area through windows, doors, vents or other openings.

DANGER CARBON MONOXIDE: using a generator indoors **CAN KILL YOU IN MINUTES.**

DANGER

Rotating parts can entangle hands, feet, hair, clothing and/or accessories.
Traumatic amputation or severe laceration can result.

Keep hands and feet away from rotating parts.
Tie up long hair and remove jewelry.
Operate equipment with guards in place.
DO NOT wear loose-fitting clothing, dangling drawstrings or items that could become caught.

DANGER

Generator produces powerful voltage.

DO NOT touch bare wires or receptacles.
DO NOT use electrical cords that are worn, damaged or frayed.
DO NOT operate generator in wet weather.
DO NOT allow children or unqualified persons to operate or service the generator
Use a ground fault circuit interrupter (GFCI) in damp areas and areas containing conductive material such as metal decking.
Use approved transfer equipment to isolate generator from your electric utility and notify your utility company before connecting your generator to your power system.

WARNING

Sparks can result in fire or electrical shock.

When servicing the generator:

Disconnect the spark plug wire and place it where it cannot contact the plug.
DO NOT check for spark with the plug removed.
Use only approved spark plug testers.

WARNING

Running engines produce heat. Severe burns can occur on contact.
Combustible material can catch fire on contact.

DO NOT touch hot surfaces.
Avoid contact with hot exhaust gases.
Allow equipment to cool before touching.
Maintain at least 3 ft. (91.4 cm) of clearance on all sides to ensure adequate cooling.
Maintain at least 5 ft. (1.5 m) of clearance from combustible materials.

WARNING

Medical and Life Support Uses.

In case of emergency, call 911 immediately.
NEVER use this product to power life support devices or life support appliances.
NEVER use this product to power medical devices or medical appliances.
Inform your electricity provider immediately if you or anyone in your household depends on electrical equipment to live.
Inform your electrical provider immediately if a loss of power would cause you or anyone in your household to experience a medical emergency.

⚠ DANGER

Fuel and fuel vapours are highly flammable and extremely explosive.
Fire or explosion can cause severe burns or death.
Unintentional startup can result in entanglement, traumatic amputation or laceration.

When adding or removing fuel:

Turn the generator off and let it cool for at least two minutes before removing the fuel cap. Loosen the cap slowly to relieve pressure in the tank.
Only fill or drain fuel outdoors in a well-ventilated area. DO NOT pump gas directly into the generator at the gas station. Use an approved container to transfer the fuel to the generator.
DO NOT overfill the fuel tank.
Always keep fuel away from sparks, open flames, pilot lights, heat and other sources of ignition.
DO NOT light or smoke cigarettes.

When starting the generator:

DO NOT attempt to start a damaged generator.
Make certain that the gas cap, air filter, spark plug, fuel lines and exhaust system are properly in place.
Allow spilled fuel to evaporate fully before attempting to start the engine.
Make certain that the generator is resting firmly on level ground.

When operating the generator:

DO NOT move or tip the generator during operation.
DO NOT tip the generator or allow fuel or oil to spill.

When transporting or servicing the generator:

Make certain that the fuel shutoff valve is in the off position and the fuel tank is empty.
Disconnect the spark plug wire.

When storing the generator:

Store away from sparks, open flames, pilot lights, heat and other sources of ignition.

⚠ WARNING

Operation of this equipment may create sparks that can start fires around dry vegetation.

A spark arrestor may be required. The operator should contact local fire agencies for laws or regulations relating to fire prevention requirements.

⚠ WARNING

Rapid retraction of the starter cord will pull hand and arm towards the engine faster than you can let go.
Unintentional startup can result in entanglement, traumatic amputation or laceration.
Broken bones, fractures, bruises or sprains could result.

When starting engine, pull the starter cord slowly until resistance is felt and then pull rapidly to avoid kickback.
DO NOT start or stop the engine with electrical devices plugged in.

⚠ CAUTION

Exceeding the generator's running capacity can damage the generator and/or electrical devices connected to it.

DO NOT overload the generator.
Start the generator and allow the engine to stabilize before connecting electrical loads.
Connect electrical equipment in the off position, and then turn them on for operation.
Turn electrical equipment off before stopping the generator.
DO NOT tamper with the governed speed.
DO NOT modify the generator in any way.

⚠ CAUTION

Improper treatment or use of the generator can damage it, shorten its life and void your warranty.

Use the generator only for intended uses.
Operate only on level surfaces.
DO NOT expose generator to excessive moisture, dust, or dirt.
DO NOT allow any material to block the cooling slots.
If connected devices overheat, turn them off and disconnect them from the generator.
DO NOT use the generator if:

- Electrical output is lost
- Equipment sparks, smokes or emits flames
- Equipment vibrates excessively

SAFETY RULES

Safety Label Locations

These labels warn you of potential hazards that can cause serious injury. Read them carefully.

If a label coming off or becomes hard to read, contact Champion Power Equipment's customer service department for possible replacement.

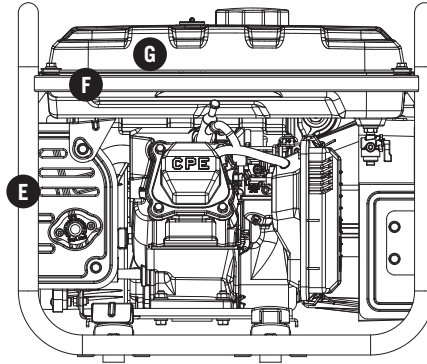
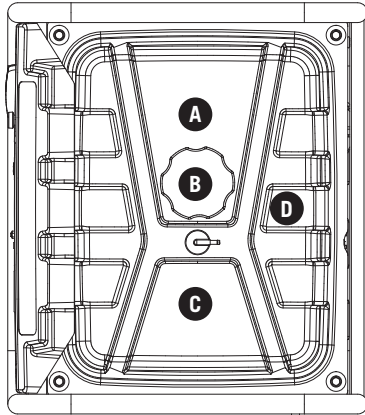

A	B	C	D
E	S		
⚠ DANGER	⚠ PELIGRO		
FOR USE IN A WEATHER PROTECTED AREA ONLY DO NOT EXPOSE TO RAIN	PARA USO EN ÁREAS DESPROTEGIDAS SOLAMENTE NO EXPOSIÓN A LA LLUVIA		
WHEN STORING GASOLINE, PROPANE (LPG) OR EQUIPMENT WITH FUEL IN IT: Store away from furnaces, stoves, water heaters or other appliances that have a pilot light or other ignition source because they can ignite the fuel.	CUANDO ALMACENE GASOLINA, GAS PROPANO (LPG) O EQUIPO CON COMBUSTIBLE ADENTRO: Almacene lejos de hornos, estufas, calentadores de agua, u otros aparatos que tengan luz piloto o otra fuente de encendido por que pueden encender el combustible.		
⚠ WARNING	⚠ ADVERTENCIA		
Read and follow operating instructions before running engine. Gasoline and propane (LPG) are extremely flammable. Check for spilled fuel or fuel leaks. If one is found, shut off fuel supply and stop engine immediately. Allow to cool at least 2 minutes before refueling.	Lea y siga las instrucciones de operación antes de encender el motor. La gasolina y el gas propano (LPG) son extremadamente inflamables. Verifique si hay combustible derramado o fugas de combustible. Si una es encontrada, apague el suministro y pare el motor inmediatamente. Permita que se enfríe por los menos 2 minutos antes de repostar.		
⚠ CAUTION	⚠ PRECAUCIÓN		
FOR ELECTRICAL EQUIPMENT ONLY	PARA EQUIPOS ELÉCTRICOS SOLAMENTE		



E	S
⚠ DANGER ⚠ PELIGRO ⚠ DANGER (EN-F-0018)	
Using a generator indoors CAN KILL YOU IN MINUTES. Generator exhaust contains carbon monoxide. This is a poison you cannot see or smell.	
NEVER use inside a home or garage, EVEN IF doors and windows are open.	ONLY use OUTSIDE and far away from windows, doors, and vents.
El uso de un generador en interiores PUEDA MATARLO EN MINUTOS. El escape del generador contiene monóxido de carbono. Este es un veneno que no se puede ver ni oler.	
Nunca lo use dentro del hogar ni el garaje, INCLUSO si las puertas y ventanas están abiertas.	
Utiliser un générateur à l'intérieur PEUT VOUS TUER EN QUELQUES MINUTES. L'échappement du générateur contient du monoxyde de carbone. Il s'agit d'un poison que vous ne pouvez ni voir ni sentir.	
No l'utilisez JAMAIS dans la maison ou le garage MÊME si les portes et les fenêtres sont ouvertes.	
Utilisez-le UNIQUEMENT À l'EXTÉRIEUR, loin des fenêtres, portes et trappes de ventilation.	



E	F
⚠ WARNING	⚠ ADVERTENCIA
DO NOT TOUCH! Do not touch generator and engine components as they may get hot and cause burns.	NO TOCAR! Los gases de escape, el generador y los componentes del motor están extremadamente CALIENTES y pueden causar quemaduras.
⚠ CAUTION	⚠ PRECAUCIÓN
A transfer switch MUST be used when connecting generator to a building's electrical system. See Owner's Manual.	Es OBLIGATORIO usar un interruptor de transferencia cuando se conecta el generador al sistema eléctrico de un inmueble. Ver el manual del propietario.
G	MISE EN GARDE
A transfer switch MUST be used when connecting generator to a building's electrical system. See Owner's Manual.	Le commutateur de transfert DOIT être utilisé pour connecter le générateur au système électrique d'un immeuble. Consulter le manuel du propriétaire.

⚠ WARNING	⚠ ADVERTENCIA	⚠ AVERTISSEMENT
Operation of this equipment may create sparks that can start fires and/or dry vegetation. A spark arrester may be required. The operator should contact local fire agencies for laws or regulations relating to fire prevention requirements. It should be installed, clear every 100 hours or every season.	La operación de este equipo puede producir chispas que pueden causar incendios o secar la vegetación seca. Un apagador de chispas puede ser necesario. El operador debe comunicarse con las agencias locales de prevención de incendios y relacionarse con los requisitos de prevención de incendios. El motor debe instalarse, limpiarlo cada 100 horas o cada temporada.	Cet équipement peut créer des étincelles et provoquer un incendie dans la végétation sèche. Un pare-étincilles peut être requis. L'opérateur doit communiquer avec le service d'incendie local pour connaître les lois et règlements en matière de prévention des incendies. S'il est à installer, nettoyer toutes les 100 heures ou chaque saison.

⚠ CAUTION	⚠ PRECAUCIÓN	⚠ MISE EN GARDE
A transfer switch MUST be used when connecting generator to a building's electrical system. See Owner's Manual.	Es OBLIGATORIO usar un interruptor de transferencia cuando se conecta el generador al sistema eléctrico de un inmueble. Ver el manual del propietario.	Le commutateur de transfert DOIT être utilisé pour connecter le générateur au système électrique d'un immeuble. Consulter le manuel du propriétaire.

Read this owner's manual before operating your generator. Familiarize yourself with the location and function of the controls and features. Save this manual for future reference.

Generator

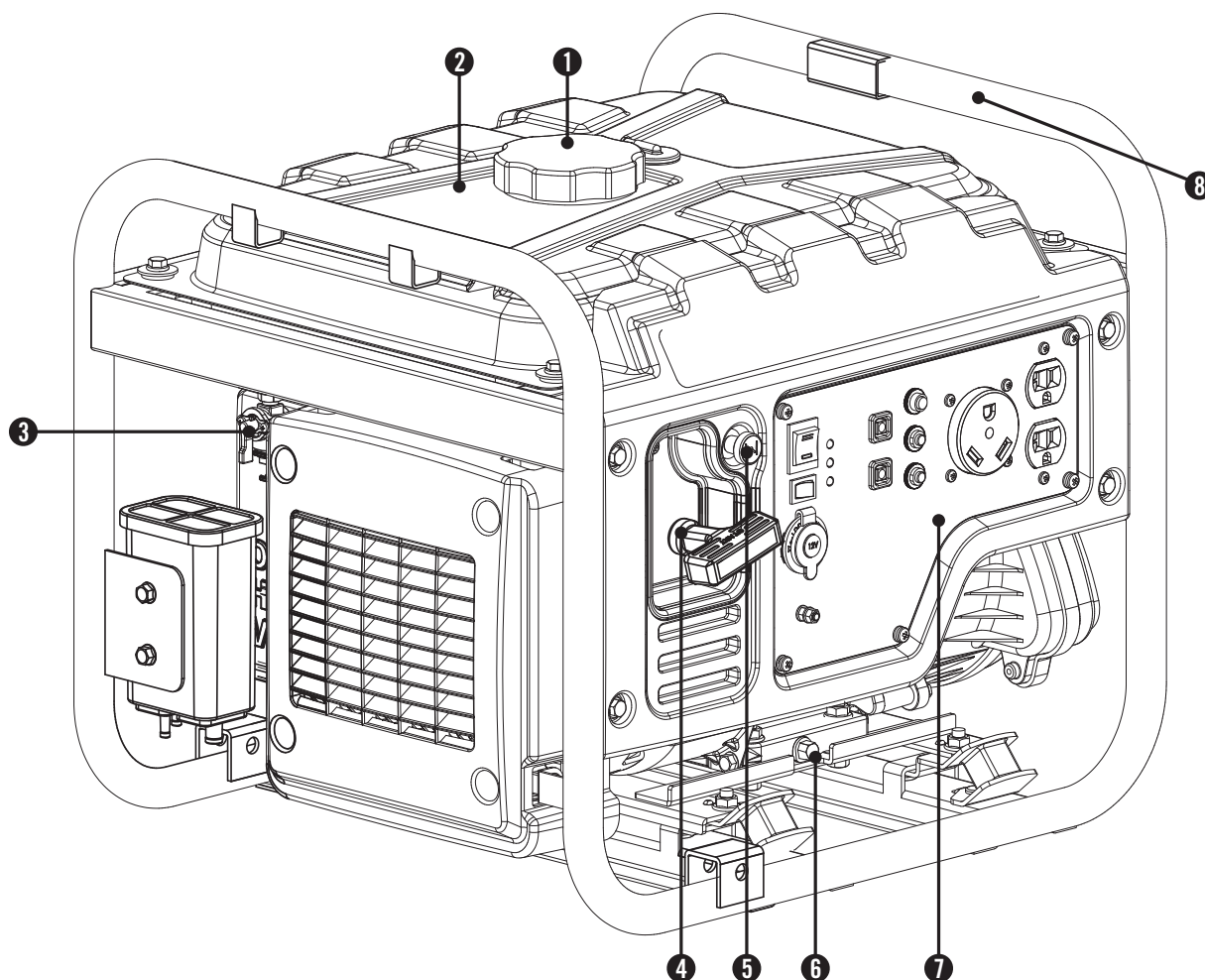

- | | |
|--|--------------------------------|
| (1) Fuel Cap – Remove to add fuel. | (5) Choke |
| (2) Fuel Tank – 2.9 gal. (11 L) | (6) Oil Drain Bolt |
| (3) Fuel Valve – Used to turn fuel supply on and off to engine. | (7) Power Panel |
| (4) Recoil Starter – Used to start the engine. | (8) Durable Steel Frame |

CONTROLS AND FEATURES

Power Panel

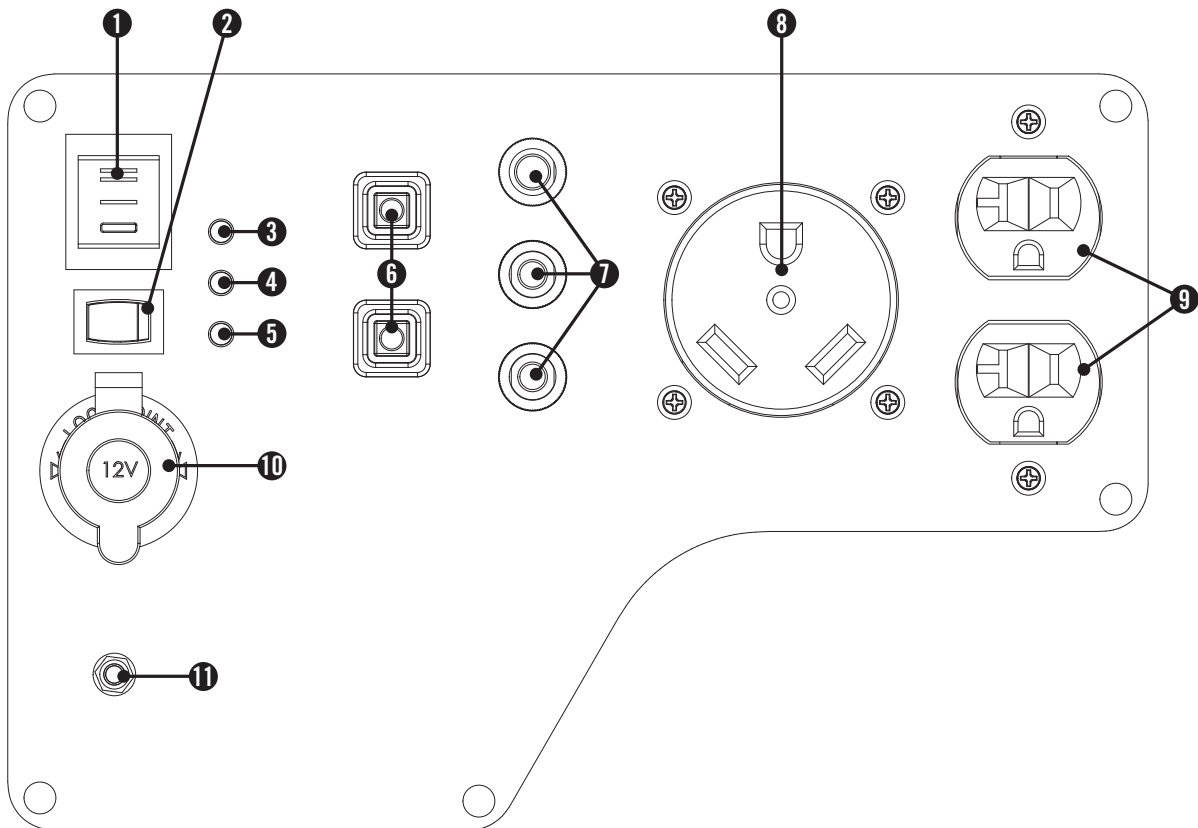













- (1) **Engine Switch**
- (2) **Economy Control Switch**
- (3) **Output Indicator Light** – Remains ON during normal operating conditions. Shuts OFF when generator is overloaded.
- (4) **Overload Indicator Light** – This light turns ON when the generator is overloaded and will cut power to the receptacles.
- (5) **Oil Warning Indicator Light** – Check oil level when this light turns on. Engine will not run when indicator is lit.
- (6) **Parallel Receptacles** – Used for parallel operation.
- (7) **Circuit Breaker (Push-button)** – Protects the generator against electrical overload.
- (8) **120 Volt AC, 30 Amp Receptacle (NEMA TT-30R)** – May be used to supply electrical power for the operation of 120 Volt AC, 30 Amp, single phase 60 Hz electrical loads.
- (9) **120 Volt AC, 20 Amp Duplex Receptacle (NEMA 5-20R)** – May be used to supply electrical power for the operation of 120 Volt AC, 20 Amp, single phase 60 Hz electrical loads.
- (10) **12V DC Automotive Receptacle***
- (11) **Ground Terminal** – Consult an electrician for local grounding regulations.

*Warning: Do not operate a device while it is plugged into the 12V DC outlet. Prolonged exposure to engine exhaust can cause serious injury or death. While charging a device do no place on the exhaust side of the generator. Extreme heat caused by exhaust can damage the device, and cause a potential fire hazard.

Power Panel Symbols

The below symbols are located on the generator power panel. Familiarize yourself with these symbols for quick reference of the components and their function.

	Engine On		Output		Ground
	Engine Switch		Overload		Parallel
	Engine Stop		Low Oil		Press to reset circuit breakers
	Economy Mode		Direct Current		RV compatible

Parts Included

Your 100302 digital hybrid portable generator ships with the following parts:

- Automotive style USB adapter (2.1A and 1A ports) 1
- Automotive style battery charger cables 1
- Oil funnel 1

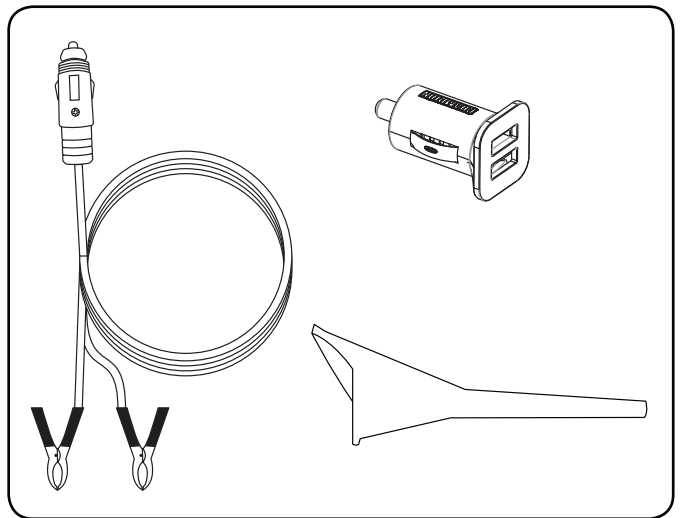

ASSEMBLY

This unit ships from our factory without oil. It must be properly serviced with fuel and oil before operation. If you have any questions regarding the assembly of your generator, call our help line at 1-877-338-0999. Please have your serial number and model number available.

Unboxing

1. Set the shipping carton on a solid, flat surface.
2. Remove everything from the carton except the generator.
3. Using the frame of the unit, carefully remove the generator from the box. (two people lifting is recommended)

Add Engine Oil

CAUTION

DO NOT attempt to crank or start the engine before it has been properly filled with the recommended type and amount of oil. Damage to the generator as a result of failure to follow these instructions will void your warranty.

NOTE

The generator rotor has a sealed, pre-lubricated ball bearing that requires no additional lubrication for the life of the bearing.

NOTE

The recommended oil type is 10W-30 automotive oil.

1. Place the generator on a flat, level surface.

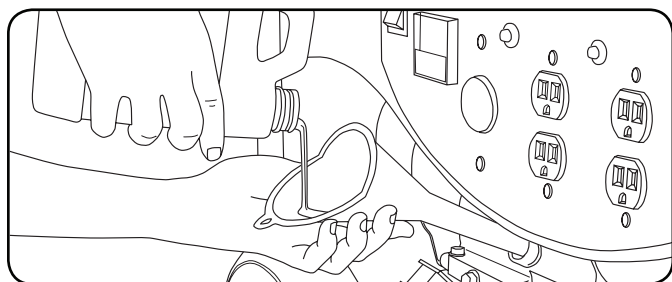

2. Remove oil fill cap/dipstick to add oil.
3. Add up to 0.6 qt. (0.6 L) of oil (not included) and replace oil fill cap/dipstick. DO NOT OVERFILL.
4. Check engine oil level daily and add as needed.

Add Engine Oil Cont'd.

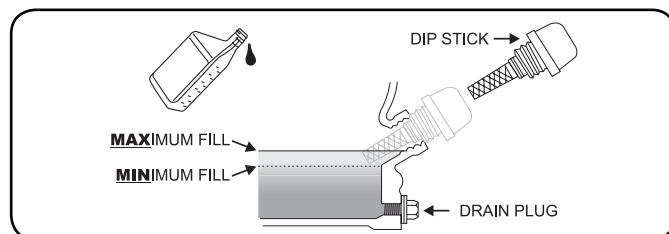

NOTE

Once oil has been added, a visual check should show oil about 1-2 threads from running out of the fill hole. If using the dipstick to check oil level, DO NOT screw in the dipstick while checking.

CAUTION

The engine is equipped with a low oil shut-off and will stop when the oil level in the crankcase falls below the threshold level.

NOTE

Check oil often during the break-in period. Refer to the Maintenance section for recommended service intervals.

NOTE

We consider the first 5 hours of run time to be the break-in period for the unit. During the break in period stay at or below 50% of the running watt rating and vary the load occasionally to allow stator windings to heat and cool. Adjusting the load will also cause engine speed to vary and help seat piston rings. After the 5 hour break-in period, change the oil.

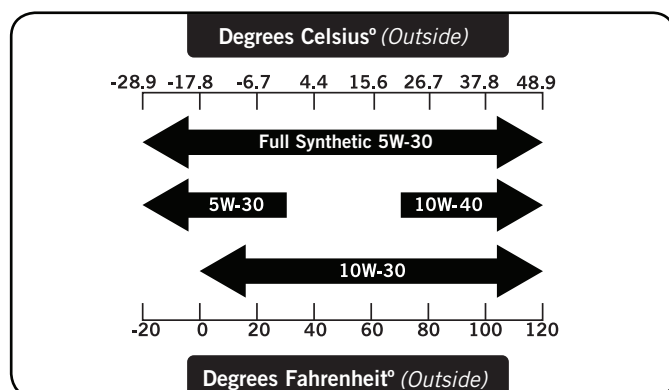

Add Engine Oil Cont'd.

NOTE

Weather will affect engine oil and engine performance. Change the type of engine oil used based on weather conditions to suit the engine needs.

NOTE

Synthetic oil may be used after the 5 hour initial break-in period. Using synthetic oil does not increase the recommended oil change interval.

Add Fuel

1. Use clean, fresh, regular unleaded fuel with a minimum octane rating of 85 and an ethanol content of less than 10% by volume.
2. DO NOT mix oil with fuel.
3. Clean the area around the fuel cap.
4. Remove the fuel cap.
5. Slowly add fuel to the tank. **DO NOT OVERFILL.** Fuel can expand after filling. A minimum of 1/4 in. (6.4 mm) of space left in the tank is required for fuel expansion, more than 1/4 in. (6.4 mm) is recommended. Fuel can be forced out of the tank as a result of expansion if it is overfilled, and can affect the stable running condition of the product. When filling the tank, it is recommended to leave enough space for the fuel to expand.

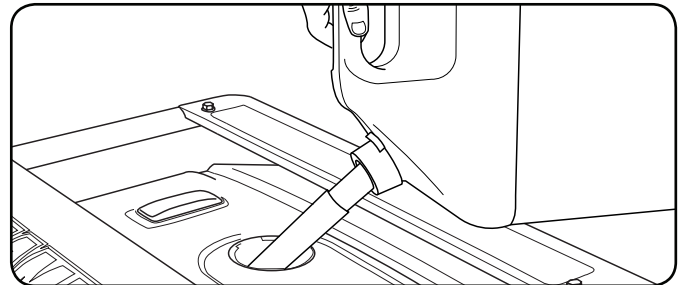

6. Screw on the fuel cap and wipe away any spilled fuel.

! CAUTION

Use regular unleaded gasoline with a minimum octane rating of 85.

Do not mix oil and gasoline.

Fill tank to approximately 1/4 in. (6.4 mm) below the top of the tank to allow for fuel expansion.

DO NOT pump gas directly into the generator at the gas station. Use an approved container to transfer the fuel to the generator.

DO NOT fill fuel tank indoors.

DO NOT fill fuel tank when the engine is running or hot.

DO NOT overfill the fuel tank.

DO NOT light cigarettes or smoke when filling the fuel tank.

! WARNING

Pouring fuel too fast through the fuel screen may result in blow back of fuel at the operator while filling.

ASSEMBLY

Add Fuel Cont'd.

NOTE

Our engines work well with 10% or less ethanol blend fuels. When using blended fuels there are some issues worth noting:

- Ethanol-gasoline blends can absorb more water than gasoline alone.
- These blends can eventually separate, leaving water or a watery goo in the tank, fuel valve and carburetor.
- With gravity-fed fuel supplies, this compromised fuel can be drawn into the carburetor and cause damage to the engine and/or potential hazards.
- There are only a few suppliers of fuel stabilizer that are formulated to work with ethanol blend fuels.
- Any damages or hazards caused by using improper fuel, improperly stored fuel, and/or improperly formulated stabilizers, are not covered by manufacture's warranty.

It is advisable to always shut off the fuel supply, run the engine to fuel starvation and drain the tank when the equipment is not in use for more than 30 days.

Grounding

Your generator must be properly connected to an appropriate ground to help prevent electric shock.

WARNING

Failure to properly ground the generator can result in electric shock.

A ground terminal connected to the frame of the generator has been provided on the power panel. For remote grounding, connect of a length of heavy gauge (12 AWG minimum) copper wire between the generator ground terminal and a copper rod driven into the ground. We strongly recommend that you consult with a qualified electrician to ensure compliance with local electrical codes.

Generator Location

NEVER operate the generator inside any building, including garages, basements, crawlspaces and sheds, enclosure or compartment, including the generator compartment of a recreational vehicle. Please consult your local authority. In some areas, generators must be registered with the local utility. Generators used at construction sites may be subject to additional rules and regulations. Generators should be on a flat, level surface at all times (even while not in operation). Generators must have at least 5 ft. (1.5 m) of clearance from all combustible material. In addition to clearance from all combustible material, generators must also have at least 3 ft. (91.4 cm) of clearance on all sides to allow for adequate cooling, maintenance and servicing. Generators should never be started or operated in the back of a SUV, camper, trailer, in the bed of a truck (regular, flat or otherwise), under staircases/stairwells, next to walls or buildings, or in any other location that will not allow for adequate cooling of the generator and/or the muffler. DO NOT contain generators during operation. Allow generators to properly cool before transport or storage. Place the generator in a well-ventilated area. DO NOT place the generator near vents or intakes where exhaust fumes could be drawn into occupied or confined spaces. Carefully consider wind and air currents when positioning generator.

Failure to follow proper safety precautions may void manufacturer's warranty.

WARNING

Do not operate or store the generator in rain, snow, or wet weather.

Using a generator or electrical appliance in wet conditions, such as rain or snow, or near a pool or sprinkler system, or when your hands are wet, could result in electrocution.

WARNING

During operation the muffler and exhaust fumes produced will become hot. If adequate cooling and breathing space are not supplied, or if the generator is blocked or contained, temperatures can become extremely heated and may lead to fire.

Grounding

The generator system ground connects the frame to the ground terminals on the power panel.

- The generator (stator winding) is isolated from the frame and from the AC receptacle ground pin.
- Electrical devices that require a grounded receptacle pin connection will not function if the receptacle ground pin is not functional.

Starting the Engine

1. Make certain the generator is on a flat, level surface.
2. Disconnect all electrical loads from the generator. Never start or stop the generator with electrical devices plugged in or turned on.
3. Turn the fuel valve to the "On" position.

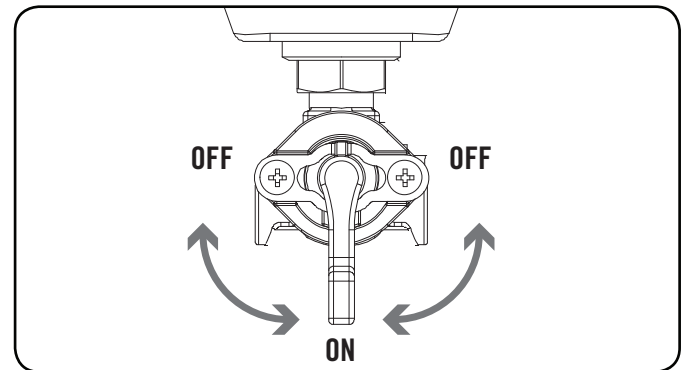

4. Pull choke lever out to the "Choke" position.

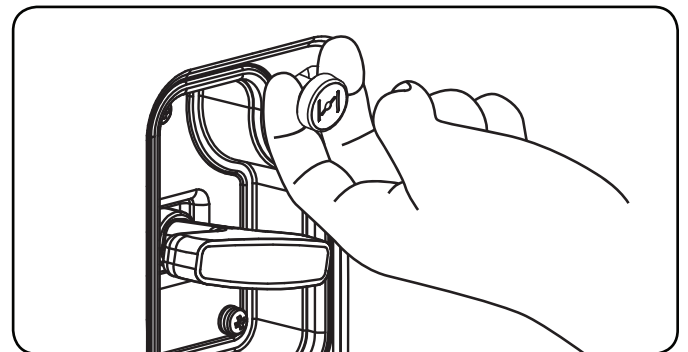

5. Turn the engine switch to the "On" position.

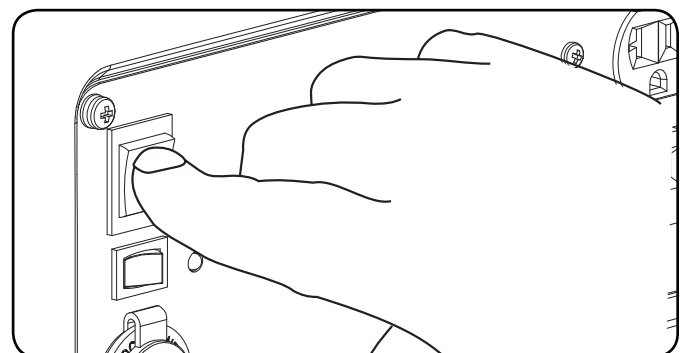

OPERATION

Starting the Engine Cont'd.

6. Pull the starter cord slowly until resistance is felt and then pull rapidly.
7. As engine warms up, push the choke lever in to the "Run" position.

NOTE

Keep choke in "Choke" position for only 1 pull of the recoil starter. After first pull, push choke in for up to the next 3 pulls of the recoil starter. Too much choke leads to sparkplug fouling/engine flooding due to the lack of incoming air. This will cause the engine not to start.

NOTE

If the engine starts but does not continue to run make certain that the generator is on a flat, level surface. The engine is equipped with a low oil sensor that will prevent the engine from running when the oil level falls below a critical threshold.

Economy Control Switch

The Economy Control switch can be activated in order to minimize fuel consumption and noise while operating the unit during times of **reduced electrical output**, allowing the engine speed to idle during periods of non-use. The engine speed automatically returns to normal when an electrical load is connected. When the economy switch is off, the engine runs at normal operating speed.

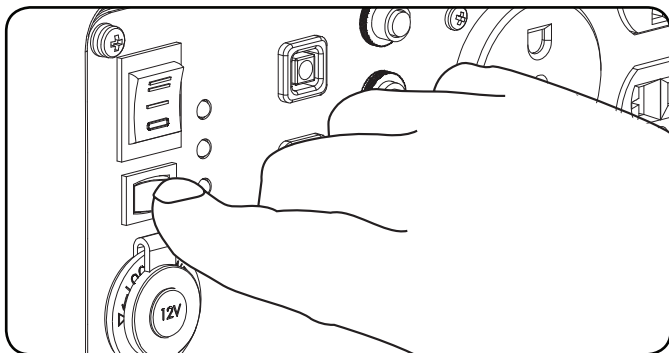

WARNING

For periods of high electrical load or momentary fluctuations, the Economy Control Switch should be turned OFF.

Connecting Electrical Loads

1. Let the engine stabilize and warm up for a few minutes after starting
2. Plug in and turn on the desired 120 Volt AC single phase, 60 Hz electrical loads.
 - DO NOT connect 3-phase loads to the generator.
 - DO NOT connect 50 Hz loads to the generator.
 - DO NOT overload the generator.

NOTE

Connecting a generator to your electric utility company's power lines or to another power source may be against the law. In addition this action, if done incorrectly, could damage your generator and appliances and could cause serious injury or even death to you or a utility worker who may be working on nearby power lines. If you plan to run a portable electric generator during an outage, please notify your electric utility company immediately and remember to plug your appliances directly into the generator. Do not plug the generator into any electric outlet in your home. Doing so could create a connection to the utility company power lines. You are responsible for ensuring that your generator's electricity does not feed back into the electric utility power lines.

If the generator will be connected to a building electrical system, consult your local utility company or a qualified electrician. Connections must isolate generator power from utility power and must comply with all applicable laws and codes.

12V DC Outlet

The 12V DC outlet can be used with the supplied charge cable and USB charger and other commercially available 12V DC automotive style plugs. The DC output is unregulated and can damage some products. Confirm your accessory input voltage range is at least 12-24V DC. When using the DC outlet turn the Economy mode switch to the "OFF" position.

WARNING

Do not operate a device while it is plugged in to the 12V DC outlet.

Prolonged exposure to engine exhaust can cause serious injury or death.

WARNING

While charging a device do not place on the exhaust side of the generator. Extreme heat caused by exhaust can damage the device, and cause a potential fire hazard.

Stopping the Engine

1. Turn off and unplug all electrical loads. Never start or stop the generator with electrical devices plugged in or turned on.
2. Let the generator run at no-load for several minutes to stabilize internal temperatures of the engine and generator.
3. Turn the fuel valve to the "OFF" position.
4. Let the engine run until fuel starvation has stopped the engine. This usually takes a few minutes.
5. Turn the engine switch to the "OFF" position.

Important: Always ensure that the fuel valve and the engine switch are in the "OFF" position when the engine is not in use.

NOTE

If the engine will not be used for a period of two (2) weeks or longer, please see the storage section for proper engine and fuel storage.

Do Not Overload Generator

Capacity

Follow these simple steps to calculate the running and starting watts necessary for your purposes.

1. Select the electrical devices you plan on running at the same time.
2. Total the running watts of these items. This is the amount of power you need to keep your items running.
3. Identify the highest starting wattage of all devices identified in step 1. Add this number to the number calculated in step 2. Surge wattage is the extra burst of power needed to start some electric driven equipment. Following the steps listed under "Power Management" will guarantee that only one device will be starting at a time.

Power Management

Use the following formula to convert voltage and amperage to watts:

$$\text{Volts} \times \text{Amps} = \text{Watts}$$

To prolong the life of your generator and attached devices, follow these steps to add electrical load:

1. Start the generator with no electrical load attached.
2. Allow the engine to run for several minutes to stabilize.
3. Plug in and turn on the first item. It is best to attach the item with the largest load first.
4. Allow the engine to stabilize.
5. Plug in and turn on the next item.
6. Allow the engine to stabilize.
7. Repeat steps 5-6 for each additional item.

NOTE

Never exceed the specified capacity when adding loads to the generator.

OPERATION

Overload Operation

The overload indicator light will turn on when the rated load is exceeded. When the maximum load is reached, the LED will blink and cut power to the receptacles.

To recover the power, shut down the generator, wait until the light turns off and restart the generator.

Parallel Operation

The Champion model 100302 is parallel ready and can be operated in parallel with another Champion unit to increase the total available electrical power. A Champion model 100319 parallel kit (optional equipment) is required for parallel operation. For a list of compatible models or to order a parallel kit, please call customer service at 1-877-338-0999 or visit www.championpowerequipment.com.

Detailed instructions for parallel kit installation and operation of the connected generators are provided in the parallel kit owner's manual.

Operation at High Altitude

The density of air at high altitude is lower than at sea level. Engine power is reduced as the air mass and air-fuel ratio decrease. Engine power and generator output will be reduced approximately 3½% for every 1000 feet of elevation above sea level. This is a natural trend and cannot be changed by adjusting the engine. At high altitudes increased exhaust emissions can also result due to the increased enrichment of the air fuel ratio. Other high altitude issues can include hard starting, increased fuel consumption and spark plug fouling. To alleviate high altitude issues other than the natural power loss, Champion Power Equipment can provide a high altitude carburetor main jet. The alternative main jet and installation instructions can be obtained by contacting Customer Support. Installation instructions are also available in the Technical Bulletin area of the Champion Power Equipment internet site.

The part number and recommended minimum altitude for the application of the high altitude carburetor main jet is listed in the table below.

In order to select the correct high altitude main jet it is necessary to identify the carburetor model. For this purpose, a code is stamped on the side of the carburetor. Select the correct main jet part number corresponding to the carburetor code found on your particular carburetor.

Carburetor Code	Main Jet	Part Number	Altitude
P22-8-H	Standard	27.131017.01.H	3500 Feet (1067 Meters)
	Altitude	27.131017.01.01.H	

WARNING

Operation using the alternative main jet at elevations lower than the recommended minimum altitude can damage the engine. For operation at lower elevations, the standard main jet must be used. Operating the engine with the wrong engine configuration at a given altitude may increase its emissions and decrease fuel efficiency and performance.

The owner/operator is responsible for all periodic maintenance.

WARNING

Never operate a damaged or defective generator.

WARNING

Tampering with the factory set governor will void your warranty.

WARNING

Improper maintenance will void your warranty.

NOTE

Maintenance, replacement, or repair of emission control devices and systems may be performed by any non-road engine repair establishment or individual.

Complete all scheduled maintenance in a timely manner. Correct any issue before operating the generator.

NOTE

For service or parts assistance, contact our help line at **1-877-338-0999**

Engine Maintenance

To prevent accidental starting, remove and ground spark plug wire before performing any service.

Oil

Change oil when the engine is warm. Refer to the oil specification to select the proper grade of oil for your operating environment.

1. Remove the oil drain plug with a 12 mm socket and extension. (not included)
2. Allow the oil to drain completely.
3. Replace the drain plug.
4. Remove oil fill cap/dipstick to add oil.
5. Add up to 0.6 qt. (0.6 L) of oil and replace oil fill cap/dipstick. **DO NOT OVERFILL.**
6. Dispose of used oil at an approved waste management facility.

Oil Cont'd.

NOTE

Once oil has been added, a visual check should show oil about 1-2 threads from running out of the fill hole. If using the dipstick to check oil level, **DO NOT** screw in the dipstick while checking.

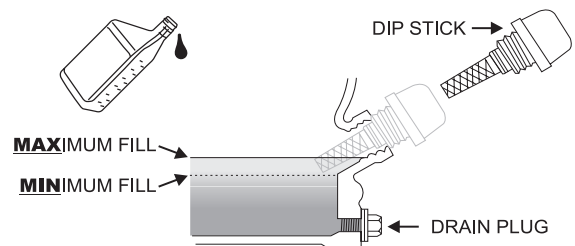

Spark Plugs

1. Remove the spark plug cable from the spark plug.
2. Use a spark plug socket tool (not included), or a 13/16 in. or 21 mm socket (not included) to remove the plug.
3. Inspect the electrode on the plug. It must be clean and not worn to produce the spark required for ignition.
4. Make certain the spark plug gap is 0.7 - 0.8 mm (0.028 - 0.031 in.).

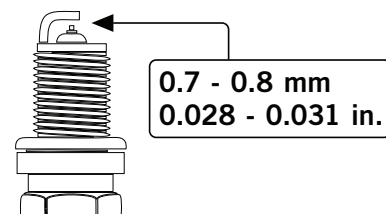

5. Refer to the spark plug recommendation chart when replacing the plug.
6. Carefully thread the plug into the engine.
7. Use the spark plug socket tool (not included) or a 13/16 in. or 21 mm socket (not included) to firmly install the plug.
8. Attach the spark plug wire to the plug.

Air Filter

1. Remove the snap-on cover holding the air filter to the assembly.
2. Remove the foam element.
3. Wash in liquid detergent and water. Squeeze thoroughly dry in a clean cloth.
4. Saturate in clean engine oil.
5. Squeeze in a clean, absorbent cloth to remove all excess oil.
6. Place the filter in the assembly.
7. Reattach the air filter cover and snap in place.

MAINTENANCE AND STORAGE

Spark Arrester

1. Allow the engine to cool completely before servicing the spark arrester.
2. Remove the two (2) screws holding the cover plate which retains the end of the spark arrester to the muffler.
3. Remove the spark arrester screen.
4. Carefully remove the carbon deposits from the spark arrester screen with a wire brush.
5. Replace the spark arrester if it is damaged.
6. Position the spark arrester in the muffler and attach with the two (2) screws.

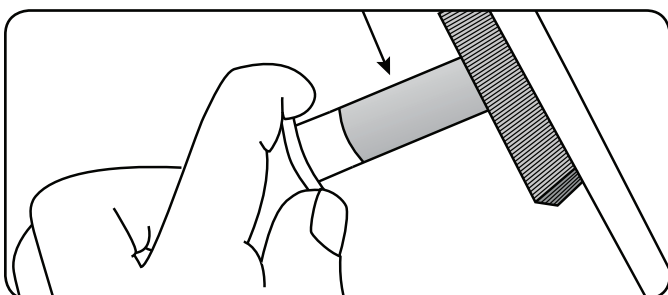

! CAUTION

Failure to clean the spark arrester will result in degraded engine performance.

NOTE

Federal and local laws and administrative requirements indicate when and where spark arresters are required. When ordered, spark arresters are required for operation of this generator in National Forest lands. In California, this generator must not be used on any forest-covered land, brush-covered land, or grass-covered land unless the engine is equipped with a spark arrester.

Adjustments

The air-fuel mixture is not adjustable. Tampering with the governor can damage your generator and your electrical devices and will void your warranty. CPE recommends that you contact our service line at **1-877-338-0999** for all other service and/or adjustment needs.

Maintenance Schedule

Follow the service intervals indicated in the following maintenance schedule.

Service your generator more frequently when operating in adverse conditions.

Contact our helpline at **1-877-338-0999** to locate the nearest Champion Power Equipment certified service dealer for your generator or engine maintenance needs.

Every 8 hours or daily	
	Check oil level
	Clean around air intake and muffler
First 5 Hours	
	Change oil
Every 50 hours or every season	
	Clean air filter
	Change oil if operating under heavy load or in hot environments
Every 100 hours or every season	
	Change oil
	Clean/Adjust spark plug
	Check/Adjust valve clearance*
	Clean spark arrester
	Clean fuel tank and filter*
Every 250 hours	
	Clean combustion chamber*
Every 3 years	
	Replace fuel line

*To be performed by knowledgeable, experienced owners or Champion Power Equipment certified dealers.

Generator Maintenance

Make certain that the generator is kept clean and stored properly. Only operate the unit on a flat, level surface in a clean, dry operating environment. DO NOT expose the unit to extreme conditions, excessive dust, dirt, moisture or corrosive vapors.

Cleaning

CAUTION

DO NOT spray engine with water.

Water can enter the generator through the cooling slots and damage the generator windings. It can also contaminate the fuel system.

Use a damp cloth to clean exterior surfaces of the generator. Use a soft bristle brush to remove dirt and oil. Use an air compressor (25 PSI) to clear dirt and debris from the generator. Inspect all air vents and cooling slots to ensure that they are clean and unobstructed.

Storage

DANGER

Gasoline, gasoline vapors and liquid petroleum gas (LPG/propane) are highly flammable and extremely explosive.

Fire or explosion can cause severe burns or death. Only fill or drain fuel outdoors in a well-ventilated area. Do not pump gasoline directly into the generator. Use an approved container to transfer the fuel to the generator. Never use a fuel container, hose, cylinder or any other fuel related item that is damaged or appears damaged. Do not overfill the fuel tank. Always keep fuel away from sparks, open flames, pilot lights, heat and other sources of ignition. Do not light or smoke cigarettes.

Short Term Storage (up to 1 year)

Gasoline in the fuel tank has a maximum shelf life of up to 1 year with the addition of properly formulated fuel stabilizers and if stored in a cool, dry place. Gasoline in the carburetor, however, WILL gum up and clog the carburetor if it isn't used or drained within 2 weeks.

Short Term Storage Cont'd.

1. Be sure all appliances are disconnected from the generator.
2. Add a properly formulated fuel stabilizer to the tank (2-3 times manufacturer's recommended amount).
3. Run the generator for 10 minutes so the treated fuel cycles through the fuel system and carburetor.
4. With the generator running, turn the fuel valve to the "OFF" position and let the generator run until fuel starvation has stopped the engine. This usually takes a few minutes.
5. Turn engine switch to the "OFF" position.
6. Allow generator to cool completely before continuing.
7. Optional: to ensure fuel is completely drained from the carburetor, use the drain bolt on the carburetor to empty any excess gasoline into an appropriate container.
8. Remove the spark plug cap and spark plug and pour about a tablespoon of oil into the cylinder.
9. Pull the recoil slowly to crank the engine to distribute the oil and lubricate the cylinder.
10. Reattach the spark plug and spark plug cap.
11. If the generator includes a battery, disconnect and charge according to [Generator Battery](#).
12. Clean the generator according to [Generator Maintenance](#).
13. Store the generator in a cool, dry place out of direct sunlight.

Long Term Storage (over 1 year)

For storage over 1 year, the fuel tank and carburetor must be completely drained of gasoline.

1. Be sure all appliances are disconnected from the generator.
2. Add a properly formulated fuel stabilizer to the fuel tank.
3. Run the generator for 10 minutes so the treated fuel cycles through the fuel system and carburetor.
4. Run Dry Option:
 - a. Let the generator run to fuel complete starvation.
 - b. Turn engine switch to the "OFF" position.
 - c. Allow generator to cool completely.
5. Drain Fuel Option:
 - a. Turn engine switch to the "OFF" position.
 - b. Allow generator to cool completely.

MAINTENANCE AND STORAGE

Long Term Storage Cont'd.

- c. Use the drain bolt on the carburetor to completely empty gasoline from the fuel tank and carburetor into an appropriate container.
- d. Replace and tighten the carburetor drain bolt.
6. Turn the fuel valve to the "OFF" position.
7. Remove the spark plug and pour about a tablespoon of oil into the cylinder. Crank the engine slowly to distribute the oil and lubricate the cylinder.
8. Reattach the spark plug and spark plug cap.
9. If the generator includes a battery, disconnect and charge according to [Generator Battery](#).
10. Clean the generator according to [Generator Maintenance](#).
11. Store the generator in a cool, dry place out of direct sunlight.

Removing from Storage

If the generator has been improperly stored for a long period of time with gasoline in the fuel tank and/or carburetor, all fuel must be drained and the carburetor must be thoroughly cleaned. This process involves technically advanced tasks. For assistance please call our Technical Support line at 1-877-338-0999. If the fuel tank and carburetor were properly emptied of all fuel prior to the generator being stored, follow the below steps when removing from storage.

1. Add fuel to the generator according to [Add Fuel](#).
2. With the engine switch in the "OFF" position, turn the fuel valve to the "ON" position. After 5 minutes check the carburetor and air filter areas for any leaking gasoline. If found, the carburetor will need to be disassembled and cleaned or replaced. If no fuel leaks are found, turn the fuel valve to the "OFF" position.
3. Check oil level and add clean, fresh oil if needed.
4. Check and clear air filter of any obstructions such as bugs or cobwebs. If necessary, clean according to [Air Filter section](#).
5. If the generator includes a battery, connect according to [Connect the Battery](#)
6. Start the generator according to [Starting the Engine](#).

NOTE

Our engines work well with 10% or less ethanol blend fuels. When using blended fuels there are some issues worth noting:

- Ethanol-gasoline blends can absorb more water than gasoline alone.
- These blends can eventually separate, leaving water or a watery goo in the tank, fuel valve and carburetor.
- With gravity-fed fuel supplies, this compromised fuel can be drawn into the carburetor and cause damage to the engine and/or potential hazards.
- There are only a few suppliers of fuel stabilizer that are formulated to work with ethanol blend fuels.
- Any damages or hazards caused by using improper fuel, improperly stored fuel, and/or improperly formulated stabilizers, are not covered by manufacture's warranty.

DANGER

Generator exhaust contains odorless and colorless carbon monoxide gas.

To avoid accidental or unintended ignition of your generator during periods of storage, the following precautions should be followed:

- When **storing the generator** make sure the engine switch and fuel valve are set to the "OFF" position.
- If your generator includes a battery, disconnect according to the Generator Battery section.

Engine Specifications

- Model YF172IV-331
- Displacement 224cc
- Type 4-Stroke OHV
- Start Type Manual

Generator Specifications

- Model 100302
- Running watts 3500
- Starting watts 4000
- AC Load 120 V
- Phase Single
- Frequency 60 Hz
- Fuel Capacity 2.9 gal. (11 L)
- Gross Weight 87.5-91.9 lb. (39.7-41.7 kg)
- Net Weight 81.5 lb. (37 kg)
- Height 17.7 in. (44.9 cm)
- Width 17.9 in. (45.5 cm)
- Length 20.5 in. (52 cm)

*Product carton styles may vary.

Fuel

Fuel capacity is 2.9 gal. (11 L). Use regular unleaded gasoline with a minimum octane rating of 85 and an ethanol content of less than 10% by volume.

Oil

Use 10W-30 automotive oil.

Oil capacity is up to 0.6 L (0.6 qt.).

DO NOT OVERFILL

Please reference the following chart for recommended oil types for use in the generator.

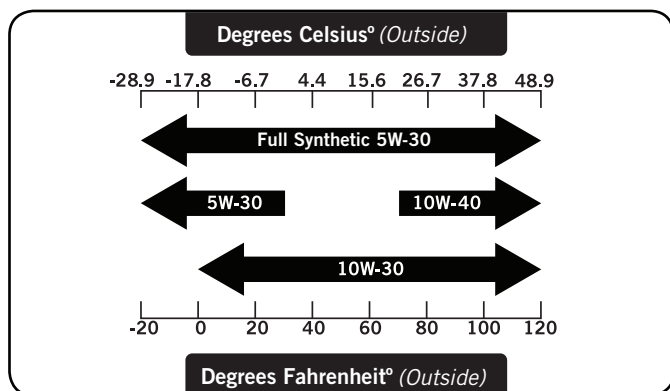

Spark Plugs

OEM spark plug: NHSP F6RTC

Replacement spark plug: NGK BPR6ES or equivalent

Make certain the spark plug gap is 0.7 - 0.8 mm or (0.028 - 0.031 in.).

Maintenance Valve Clearance

- Intake: 0.13 - 0.17 mm (0.005 - 0.007 in.)

- Exhaust: 0.18 - 0.22 mm (0.007 - 0.009 in.)

Note: Tech bulletin regarding the valve adjustment procedure is on www.championpowerequipment.com.

An Important Message About Temperature

Your Champion Power Equipment product is designed and rated for continuous operation at ambient temperatures up to 40°C (104°F). When your product is needed your product may be operated at temperatures ranging from -15°C (5°F) to 50°C (122°F) for short periods. If the product is exposed to temperatures outside this range during storage, it should be brought back within this range before operation. In any event, the product must always be operated outdoors, in a well-ventilated area and away from doors, windows and other vents.

NOTE

Weather will affect engine oil and engine performance. Change the type of engine oil used based on weather conditions to suit the engine needs.

SPECIFICATIONS

Parts Diagram

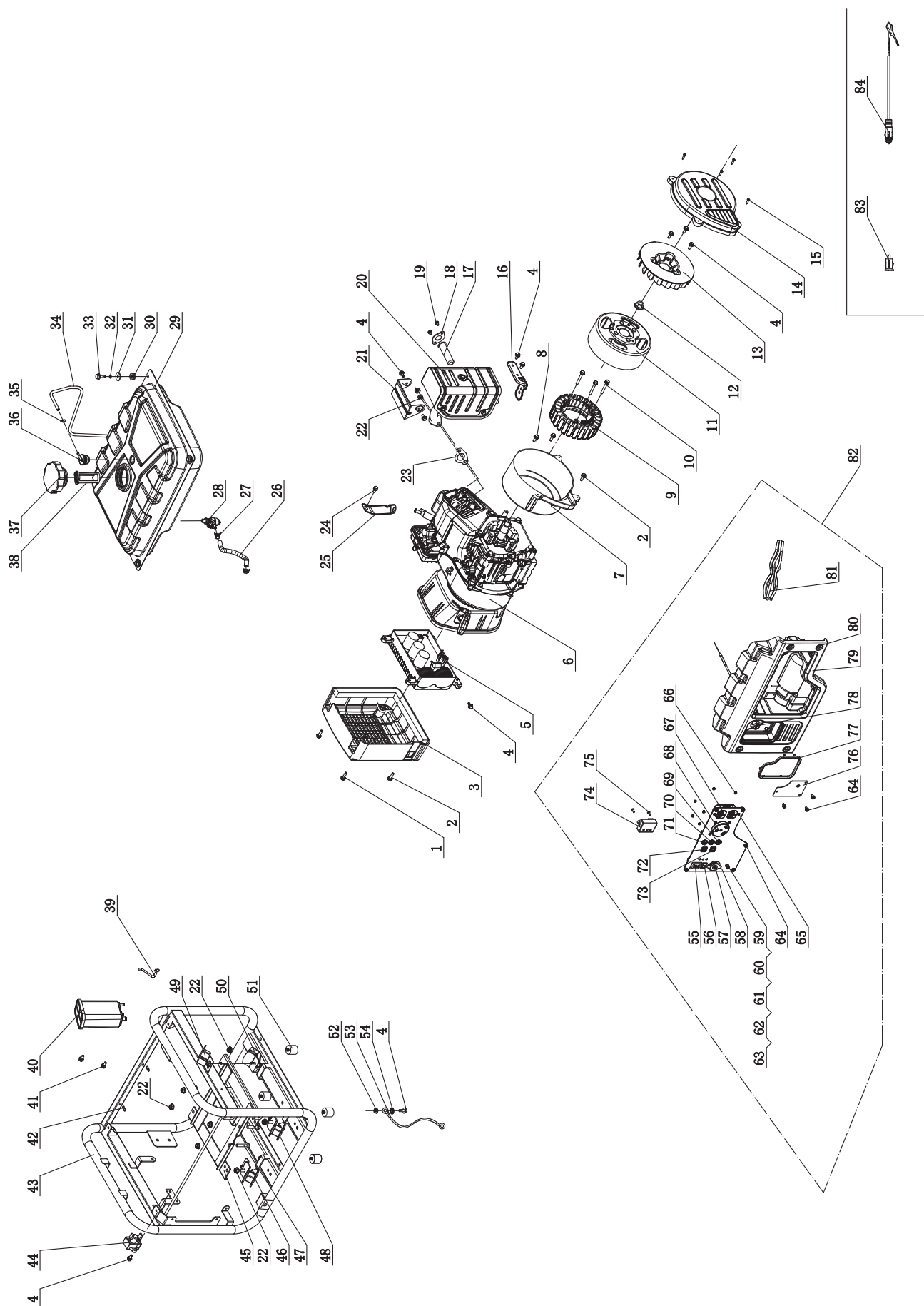

#	Part Number	Description	Qty
1	1.5789.0625	Flange Bolt M6 x 25	2
2	1.5789.0620	Flange Bolt M6 x 20	4
3	85.220005.01	Protection Cover, Control Unit	1
4	1.5789.0612	Flange Bolt M6 x 12	10
5	85.221000.04	Control Unit, 3.3KW, 120V/60Hz, Wireless Parallel	1
6	85.401	Engine	1
7	85.190002.01	End Housing, Motor	1
8	1.5789.0615	Flange Bolt M6 x 15	1
9	85.191200.03	Stator Assembly	1
10	1.9074.14.0650	Bolt/Washer Assembly M6 x 50	4
11	85.191100.03	Rotor Assembly	1
12	2.02.006	Nut M14 x 1.5	1
13	83.190001.01	Fan, Generator	1
14	85.190003.01	End Cover, Generator	1
15	1.845.4219	Screw ST4.2 x 19	4
16	85.100100.01.2	Bracket, Muffler	1
17	46.101300.08	Spark Arrester Assembly	1
18	46.101503.08	Plate, Spark Arrester	1
19	1.9074.4.0514	Screw/Washer Assembly M5 x 14	2
20	85.101000.01.2	Muffler Assembly	1
21	85.101203.01.2	Cover, Exhaust Pipe	1
22	1.6177.1.08	Lock Nut M8, Flange	18
23	26.100001.00	Gasket, Muffler	1
24	1.5789.0608	Flange Bolt M6 x 8	1
25	23.090006.21	Holder, Air Cleaner	1
26	85.070011.01	Pipe, Fuel, 140mm	1
27	2.06.007	Clamp, Ø8 x b6	2
28	85.070400.01	Fuel Valve	1
29	85.071000.02.48	Fuel Tank, 11L, Yellow	1
30	122.070015.01	Mount Vibration, Fuel Tank	4
31	2.03.004.1	Washer, Ø24 x Ø6.5 x 1.5, Black	4
32	1.93.06	Lock Washer Ø6	4
33	1.5789.0620.1	Flange Bolt M6 x 20, Black	4
34	24.070014.01	Pipe, Reversal Valve, 720mm	1
35	2.06.006	Clamp, Ø7 x Ø1	3
36	24.070800.00	Reversal Valve	1
37	122.070100.07	Fuel Tank Cap	1
38	122.070300.03	Fuel Filter	1
39	85.070014.01	Pipe, Air Cleaner	1
40	122.070700.00	Carbon Canister, 320CC	1
41	1.5789.0612.1	Flange Bolt M6 x 12, Black	2
42	2.05.001	Clamp, Ø8 x 6.5	2
43	61141.2.2	Frame	1

#	Part Number	Description	Qty
44	5.1800.003	Rectifier	1
45	85.201600.01	Supporter	1
46	85.201200.01	Motor Mount, 1	1
47	1.5789.0832	Flange Bolt M8 x 32	4
48	85.201200.02	Motor Mount, 2	2
49	85.100007.01	Insulation Board, Motor Mount	1
50	85.201200.03	Motor Mount, 3	1
51	122.201400.01	Rubber, Support	4
52	1.6177.1.06	Lock Nut M6, Flange	1
53	5.1900.093	Grounding Line	1
54	1.862.06	Lock Washer Ø6, Toothed	1
55	5.1000.004.1	Ignition Switch, Black	1
56	5.1010.003.1	Switch, Economy	1
57	5.1110.005	Receptacle, DC 12V	1
58	85.01.1.2	Control Panel, Black	1
59	1.5783.0520.3	Bolt M5 x 20, Green	1
60	1.93.05.3	Lock Washer Ø5, Green	2
61	1.862.05	Lock Washer Ø5, Toothed	1
62	1.6170.05.3	Nut M5, Green	2
63	1.97.1.05.3	Washer Ø5, Green	1
64	1.9074.4.0514.1	Screw/Washer Assembly M5 x 14, Black	8
65	1.9074.4.0414.1	Screw/Washer Assembly M4 x 14, Black	6
66	1.6177.1.04.1	Lock Nut M4, Flange, Black	6
67	5.1120.010	Receptacle 5-20R Duplex	1
68	5.1120.036	Receptacle TT-30R	1
69	5.1210.930	30Amp Circuit Breaker, Push Button	1
70	5.1210.920	20Amp Circuit Breaker, Push Button	1
71	5.1200.308	8Amp Circuit Breaker, Push Button	1
72	83.210001.00.3	Connect Port, 125V/25A, Red	1
73	83.210001.00.1	Connect Port, 125V/25A, Black	1
74	83.210016.00	Speed Limiter	1
75	1.818.0514.3	Screw, M5 x 14, Green	2
76	85.061200.01.2	Guide Plate, Rope, Black	1
77	85.200106.01	Protector, Front Cover	1
78	85.130300.01	Pull Choke Assembly	1
79	85.210002.01	Control Box	1
80	1.5789.0615.1	Flange Bolt M6 x 15, Black	4
81	100302.21.10	Wire Assembly	1
82	100302.21	Control Panel Assembly	1
83	9.1700.003	Plug, USB 5V/2.1A	1
84	9.1600.009	Cables, 12V, 2m, CSA	1

SPECIFICATIONS

Engine Parts Diagram

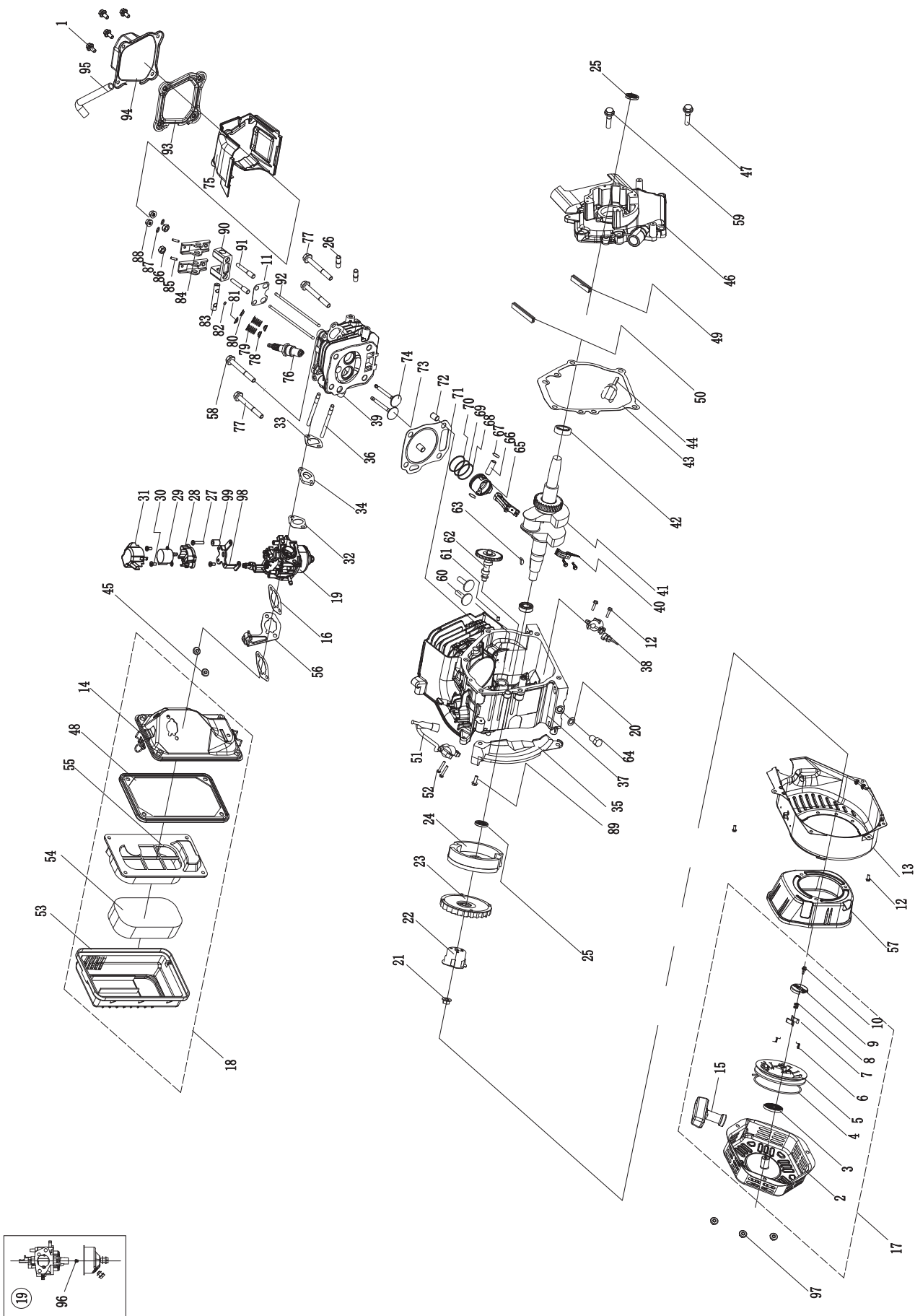

#	Part Number	Description	Qty
1	1.5789.0615	Flange Bolt M6 x 15	4
2	85.061100.00.2	Cover, Recoil Starter, Black	1
3	21.061005.00	Spring, Recoil Starter	1
4	2.10.003.1	Rope Ø4 x 1550, Black	1
5	21.061001.01	Reel, Recoil Starter	1
6	45.060003.00	Spring, Ratchet	2
7	45.060002.00	Starter Ratchet, Steel	2
8	45.060009.00	Spring Guide, Ratchet	1
9	45.060007.00	Ratchet Guide	1
10	45.060008.00	Screw, Ratchet Guide	1
11	24.040004.00	Guide Plate, Push Rod	1
12	1.5789.0612	Flange Bolt M6 x 12	6
13	85.080100.01.48	Fan Cover, Yellow	1
14	85.091100.01	Base, Air Cleaner	1
15	21.061300.00	Handle, Recoil, Soft	1
16	24.130004.20	Gasket, Air Cleaner	2
17	22.061000.00	Recoil Assembly	1
18	85.091000.01	Air Cleaner Assembly	1
19	85.131000.02	Carburetor	1
20	2.03.016	Washer Ø10 x Ø16 x 1.5, Drain Bolt	1
21	2.02.006	Nut M14 x 1.5	1
22	23.060001.01	Pulley, Starter	1
23	27.080001.00	Cooling Fan	1
24	24.120100.06	Flywheel	1
25	2.11.001	Oil Seal Ø25 x Ø41.3 x 6	2
26	2.01.010	Stud Bolt M8 x 35	2
27	1.9074.4.0420.1	Screw M4 x 20	1
28	85.132100.02	Support, Stepper Motor	1
29	81.132200.00	Stepper Motor	1
30	1.9074.3.0408	Screw M4 x 8	3
31	81.132001.00	Cover, Stepper Motor	1
32	22.130003.00	Gasket, Carburetor	1
33	24.130002.00	Gasket, Insulator	1
34	27.130001.00	Insulator, Carburetor	1
35	23.080600.00	Air Guide, Right Side	1
36	2.01.003	Stud Bolt M6 x 90	2
37	85.030100.01	Crankcase	1
38	21.127000.02	Oil Level Sensor	1
39	26.010100.01	Cylinder Head, 224cc	1
40	27.050200.00	Connecting Rod	1
41	85.050100.01	Crankshaft	1
42	1.276.6205	Bearing 6205	2
43	24.030008.00	Gasket, Crankcase Cover	1
44	46.031000.00.48	Oil Dipstick Assembly, Yellow	1
45	1.6177.06	Flange Nut M6	2
46	85.030007.01	Cover, Crankcase	1
47	1.5789.0832.0.8	Flange Bolt M8 x 32	5
48	23.091002.21	Seal, Air Cleaner	1
49	27.030013.01	Seal Strip, Crankcase Cover, Short	1
50	27.030013.00	Seal Strip, Crankcase Cover, Long	1

#	Part Number	Description	Qty
51	22.123000.02	Ignition Coil	1
52	1.5789.0625	Flange Bolt M6 x 25	2
53	27.091200.01	Cover, Air Cleaner	1
54	23.091003.21	Element, Air Cleaner	1
55	23.091001.21	Separator, Air Cleaner	1
56	85.130200.01	Support, Choker Rod	1
57	85.220005.02	Protective Cover, Control Unit, Engine	1
58	2.08.121	Flange Bolt M10 x 65	1
59	1.5789.0835.0.8	Flange Bolt M8 x 35	1
60	25.040013.00	Lifter, Valve	2
61	2.04.001	Dowel Pin Ø9 x 14	2
62	27.041000.00	Camshaft	1
63	2.14.012	Woodruff Key 4 x 7.5 x 19	1
64	2.08.037	Drain Bolt M10 x 1.25 x 25	1
65	27.050005.00	Piston	1
66	23.050003.00	Pin, Piston	1
67	2.09.001	Circlip Ø18 x Ø1	2
68	27.050303.00	Ring, Oil	1
69	27.050302.00	Ring, Second Piston	1
70	27.050301.00	Ring, First Piston	1
71	27.030009.01	Gasket, Cylinder Head	1
72	2.04.003	Dowel Pin Ø10 x 14	2
73	23.040002.02	Valve, Intake	1
74	23.040006.02	Valve, Exhaust	1
75	85.080200.01	Air Shroud, Cylinder	1
76	2.15.002(F6RTC)	Spark Plug F6RTC	1
77	1.5789.0865	Flange Bolt M8 x 65	3
78	23.040017.00	Oil Seal, Valve, Steel	2
79	21.040003.00	Spring, Valve	2
80	21.040007.00	Retainer, Exhaust Valve Spring	1
81	21.040001.00	Retainer, Intake Valve Spring	1
82	21.040008.00	Rotator, Exhaust Valve	1
83	24.040202.00	Shaft, Rocker Arm	1
84	22.040009.00	Rocker Arm	2
85	22.040012.00	Screw, Valve Adjustment	2
86	21.040021.00	Nut M6 x 0.5, Lock	2
87	1.97.1.06	Washer Ø6	2
88	1.6177.1.06	Lock Nut M6, Flange	2
89	1.5789.0620	Flange Bolt M6 x 20	1
90	24.040201.00	Retainer, Rocker Arm	1
91	23.040010.00	Bolt, Rocker Arm	2
92	27.040005.00	Push Rod	2
93	21.020002.01	Gasket, Cylinder Head Cover	1
94	24.021000.00	Cover, Cylinder Head	1
95	23.020001.02	Breather Tube, 112 + 35 mm	1
96	27.131017.01	Main Jet, Standard	1
	27.131017.01.01	Main Jet, Altitude	/
97	1.6177.1.05	Lock Nut M5, Flange	3
98	85.130005.02	Support, Stepper Motor	1
99	2.13.034	Bush Ø5 x Ø10 x 12	1

SPECIFICATIONS

Wiring Diagram

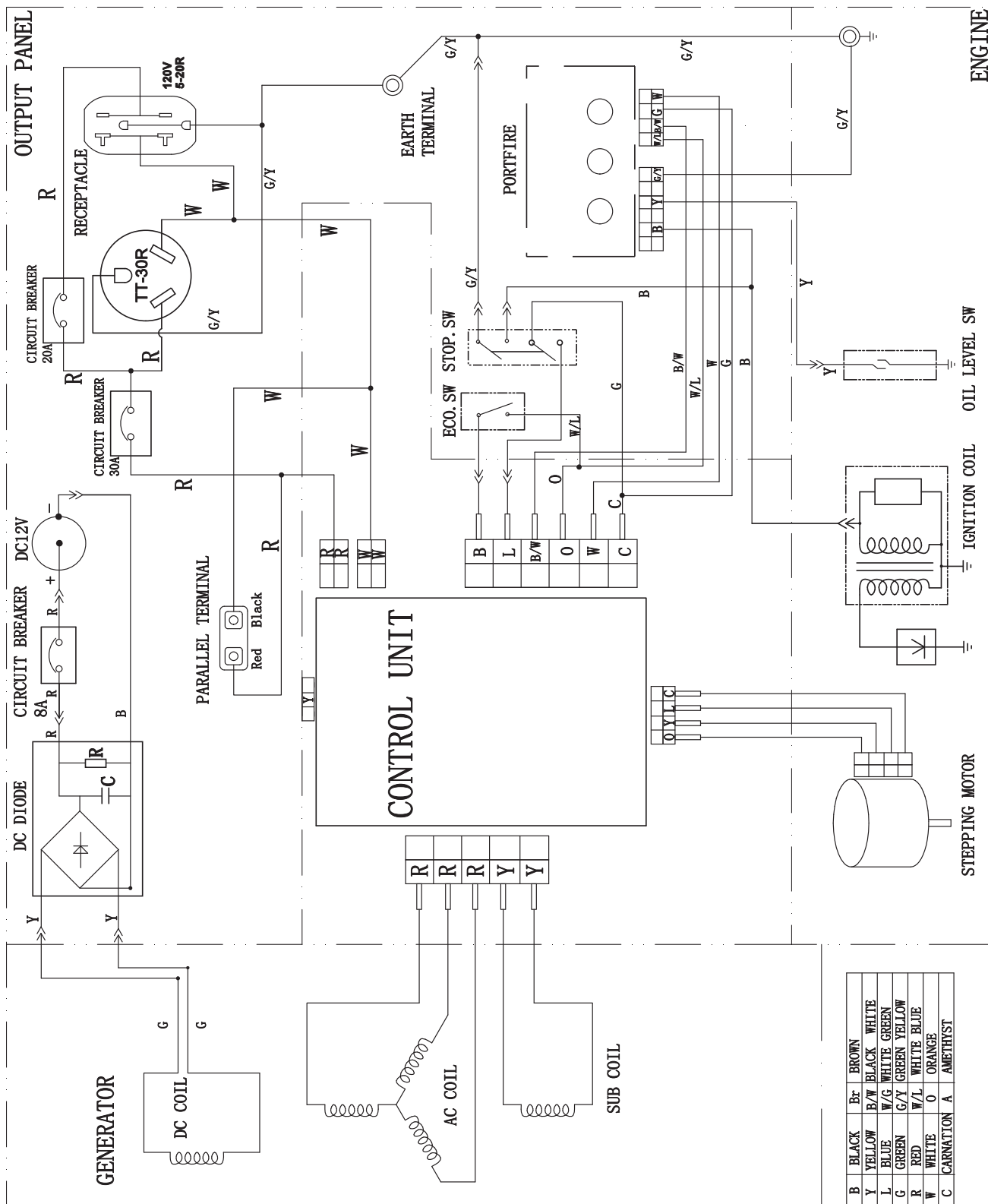

Problem	Cause	Solution
Generator will not start	No fuel	Add fuel
	Faulty spark plug	Replace spark plug
	Unit loaded during start up	Remove load from unit
Generator will not start; Generator starts but runs roughly	Low oil level	Fill crankcase to the proper level
		Place generator on a flat, level surface
	Choke in the wrong position	Adjust choke
Generator shuts down during operation	Spark plug wire loose	Attach wire to spark plug
	Out of fuel	Fill fuel tank
	Low oil level	Fill crankcase to the proper level. Place generator on a flat, level surface
Generator cannot supply enough power or overheating	Generator is overloaded	Review load and adjust. See "Power Management"
	Insufficient ventilation	Check for air restriction. Move to a well ventilated area
No AC output	Cable not properly connected	Check all connections
	Connected device is defective	Replace defective device
	Circuit breaker is open	Reset circuit breaker
	Loose wiring	Inspect and tighten wiring connections
	Other	Contact the help line
Repeated circuit breaker tripping	Overload	Review load and adjust. See "Power Management"
	Faulty cords or device	Check for damaged, bare or frayed wires. Replace defective device

For further technical support:

Technical Service

Mon – Fri 8:30 AM – 5:00 PM (PST/PDT)

Toll Free: 1-877-338-0999

tech@championpowerequipment.com