

# PRO-FORM<sup>®</sup>

## 705 CST

[www.proform.com](http://www.proform.com)

Model No. PFTL80916.0

Serial No. \_\_\_\_\_

Write the serial number in the space above for reference.

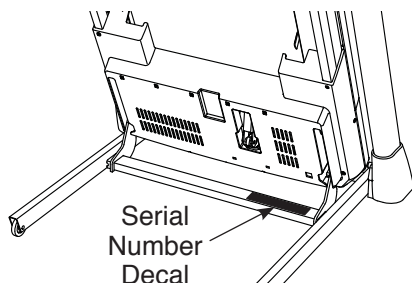

### ACTIVATE YOUR WARRANTY

To register your product and activate your warranty today, go to [www.proformservice.com/registration](http://www.proformservice.com/registration).

### CUSTOMER CARE

For service at any time, go to [www.proformservice.com](http://www.proformservice.com).

Or call 1-888-533-1333  
Mon.–Fri. 6 a.m.–6 p.m. MT  
Sat. 8 a.m.–12 p.m. MT

Please do not contact the store.

### ⚠ CAUTION

Read all precautions and instructions in this manual before using this equipment. Save this manual for future reference.

## USER'S MANUAL

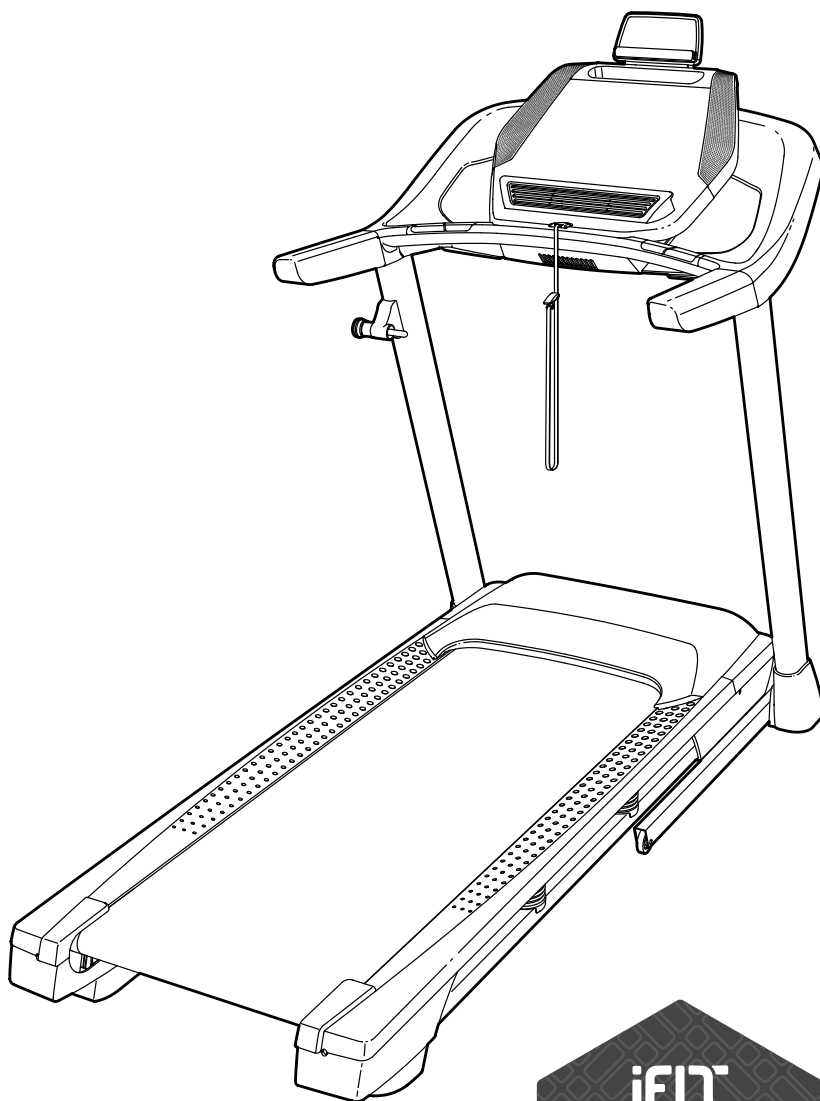

# TABLE OF CONTENTS

WARNING DECAL PLACEMENT ..... 2

IMPORTANT PRECAUTIONS..... 3

BEFORE YOU BEGIN..... 6

PART IDENTIFICATION CHART..... 7

ASSEMBLY..... 8

HOW TO USE THE TREADMILL..... 16

FCC INFORMATION..... 24

HOW TO FOLD AND MOVE THE TREADMILL..... 25

MAINTENANCE AND TROUBLESHOOTING..... 26

EXERCISE GUIDELINES..... 29

PART LIST..... 31

EXPLODED DRAWING..... 32

ORDERING REPLACEMENT PARTS..... Back Cover

LIMITED WARRANTY..... Back Cover

## WARNING DECAL PLACEMENT

This drawing shows the locations of the warning decals. **If a decal is missing or illegible, call the telephone number on the front cover of this manual and request a free replacement decal. Apply the decal in the location shown.** Note: The decals may not be shown at actual size.

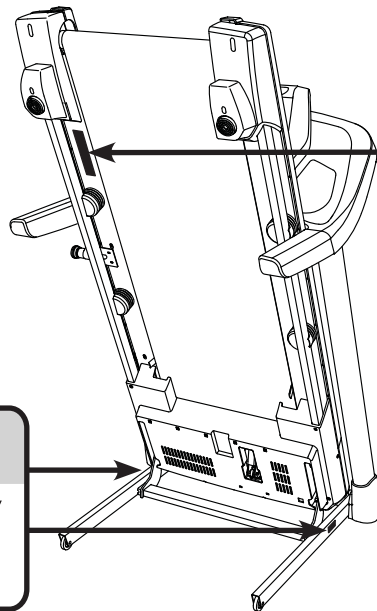

**WARNING:**

Protect yourself and others from risk of serious injury. Read the user's manual, and:

- Stand only on the side rails when starting or stopping treadmill.
- Change speed in small increments.
- Hold handrails to prevent falling, and always wear the safety clip while operating the treadmill.
- Stop if you feel faint, dizzy, or short of breath.
- Fully engage the storage latch before the treadmill is moved or stored.
- Incline should be set to zero before folding the treadmill into a storage position.
- Never allow children on or around the treadmill.
- Remove the safety key when treadmill is not in use.
- Keep clothing, fingers, and hair away from moving parts.
- Never try to adjust or fix the belt while it is moving.
- Always wear athletic shoes while operating the treadmill.

PROFORM and IFIT are registered trademarks of ICON Health & Fitness, Inc. App store is a trademark of Apple Inc., registered in the U.S. and other countries. Android and Google Play are trademarks of Google Inc. The BLUETOOTH® word mark and logos are registered trademarks of Bluetooth SIG, Inc. and are used under license. IOS is a trademark or registered trademark of Cisco in the U.S. and other countries and is used under license.

# IMPORTANT PRECAUTIONS

**⚠️ WARNING:** To reduce the risk of burns, fire, electric shock, or injury to persons, read all important precautions and instructions in this manual and all warnings on your treadmill before using your treadmill. ICON assumes no responsibility for personal injury or property damage sustained by or through the use of this product.

1. It is the responsibility of the owner to ensure that all users of this treadmill are adequately informed of all warnings and precautions.
2. Before beginning any exercise program, consult your physician. This is especially important for persons over age 35 or persons with pre-existing health problems.
3. The treadmill is not intended for use by persons with reduced physical, sensory, or mental capabilities or lack of experience and knowledge, unless they have been given supervision or instruction concerning use of the treadmill by someone responsible for their safety.
4. Use the treadmill only as described in this manual.
5. The treadmill is intended for home use only. Do not use the treadmill in any commercial, rental, or institutional setting.
6. Keep the treadmill indoors, away from moisture and dust. Do not put the treadmill in a garage or covered patio, or near water.
7. Place the treadmill on a level surface, with at least 8 ft. (2.4 m) of clearance behind it and 2 ft. (0.6 m) on each side. Do not place the treadmill on any surface that blocks air openings. To protect the floor or carpet from damage, place a mat under the treadmill.
8. Do not operate the treadmill where aerosol products are used or where oxygen is being administered.
9. Keep children under age 13 and pets away from the treadmill at all times.
10. The treadmill should be used only by persons weighing 325 lbs. (148 kg) or less.
11. Never allow more than one person on the treadmill at a time.
12. Wear appropriate exercise clothes while using the treadmill. Do not wear loose clothes that could become caught in the treadmill. Athletic support clothes are recommended for both men and women. *Always wear athletic shoes. Never use the treadmill with bare feet, wearing only stockings, or in sandals.*
13. Plug the power cord into a surge suppressor (not included), and plug the surge suppressor into an appropriate outlet (see page 16). To avoid overloading the circuit, do not plug other electrical devices, except for low-power devices such as cell phone chargers, into the surge suppressor or into an outlet on the same circuit.
14. Use only a surge suppressor that meets all of the specifications described on page 16. To purchase a surge suppressor, see your local PROFORM dealer, call the telephone number on the front cover of this manual, or see your local electronics store.
15. Failure to use a properly functioning surge suppressor could result in damage to the control system of the treadmill. If the control system is damaged, the walking belt may slow, accelerate, or stop unexpectedly, which may result in a fall and serious injury.
16. Keep the power cord and the surge suppressor away from heated surfaces.
17. Never move the walking belt while the power is turned off. Do not operate the treadmill if the power cord or plug is damaged, or if the treadmill is not working properly. (See MAINTENANCE AND TROUBLESHOOTING on page 26 if the treadmill is not working properly.)
18. Read, understand, and test the emergency stop procedure before using the treadmill (see HOW TO TURN ON THE POWER on page 18). Always wear the clip while using the treadmill.

19. Always stand on the foot rails when starting or stopping the walking belt. Always hold the handrails while using the treadmill.
20. When a person is walking on the treadmill, the noise level of the treadmill will increase.
21. Keep fingers, hair, and clothing away from the moving walking belt.
22. The treadmill is capable of high speeds. Adjust the speed in small increments to avoid sudden jumps in speed.
23. The heart rate monitor is not a medical device. Various factors, including the user's movement, may affect the accuracy of heart rate readings. The heart rate monitor is intended only as an exercise aid in determining heart rate trends in general.
24. Never leave the treadmill unattended while it is running. Always remove the key, press the power switch into the off position (see the drawing on page 6 for the location of the power switch), and unplug the power cord when the treadmill is not in use.
25. Do not attempt to move the treadmill until it is properly assembled. (See ASSEMBLY on page 8 and HOW TO FOLD AND MOVE THE TREADMILL on page 25.) You must be able to safely lift 45 lbs. (20 kg) to move the treadmill.
26. When folding or moving the treadmill, make sure that the storage latch is holding the frame securely in the storage position.
27. Do not change the incline of the treadmill by placing objects under the treadmill.
28. Never insert any object into any opening on the treadmill.
29. Inspect and properly tighten all parts each time the treadmill is used.
30. **DANGER:** Always unplug the power cord immediately after use, before cleaning the treadmill, and before performing the maintenance and adjustment procedures described in this manual. Never remove the motor hood unless instructed to do so by an authorized service representative. Servicing other than the procedures in this manual should be performed by an authorized service representative only.
31. Over exercising may result in serious injury or death. If you feel faint, if you become short of breath, or if you experience pain while exercising, stop immediately and cool down.

**SAVE THESE INSTRUCTIONS**

# PROTECT

YOUR FITNESS EQUIPMENT  
WITH AN EXTENDED SERVICE PLAN

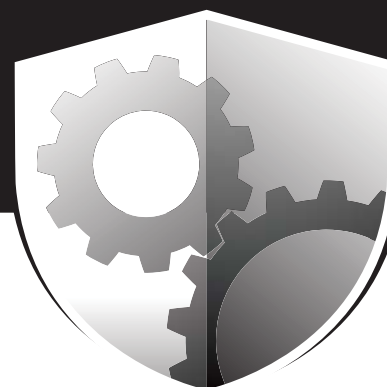

Your new fitness equipment is not an ordinary purchase; it is an investment in your health and well being for years to come.

As the leading provider of manufacturer's extended service plans, ICON strives to protect your equipment and your future.

Please review the following service plans and find one that best fits your needs.

## PREVENTIVE MAINTENANCE SERVICE PLANS

Equipment Price	3-Year Plan	5-Year Plan
\$0.00 to \$1000.00	\$199.99	\$289.99
\$1001.00 to \$1500.00	\$259.99	\$379.99
\$1501.00 to \$2500.00	\$339.99	\$489.99
(Bikes/Systems Only) \$0.00 to \$2500.00	\$139.99	NA

Features:

- Includes an annual preventive maintenance and performance check at your convenience
- Unlimited in-home repairs; no shipping required
- Covers parts and labor on all manufacturer's defects, as well as wear and tear on parts
- Up to 5 years of coverage available

## STANDARD SERVICE PLANS

Equipment Price	1-Year Plan	2-Year Plan	3-Year Plan
\$0.00 to \$300.00	\$29.99	\$39.99	\$59.99
\$301.00 to \$1000.00	\$89.99	\$119.99	\$149.99
\$1001.00 to \$2000.00	\$109.99	\$139.99	\$179.99
\$2001.00 to \$3000.00	\$179.99	\$209.99	\$239.99

Features:

- Unlimited in-home repairs; no shipping required
- Covers parts and labor on all manufacturer's defects, as well as wear and tear on parts
- Up to 3 years of coverage available

To protect your fitness equipment today, please  
call Customer Care at **1-800-677-3838.**  
Or, visit us online at **www.utserv.com.**



# BEFORE YOU BEGIN

Thank you for selecting the new PROFORM® 705 CST treadmill. The 705 CST treadmill provides an impressive selection of features designed to make your workouts at home more effective and enjoyable.

**For your benefit, read this manual carefully before you use the treadmill.** If you have questions after reading this manual, please see the front cover of this

manual. To help us assist you, note the product model number and serial number before contacting us. The model number and the location of the serial number decal are shown on the front cover of this manual.

Before reading further, please familiarize yourself with the parts that are labeled in the drawing below.

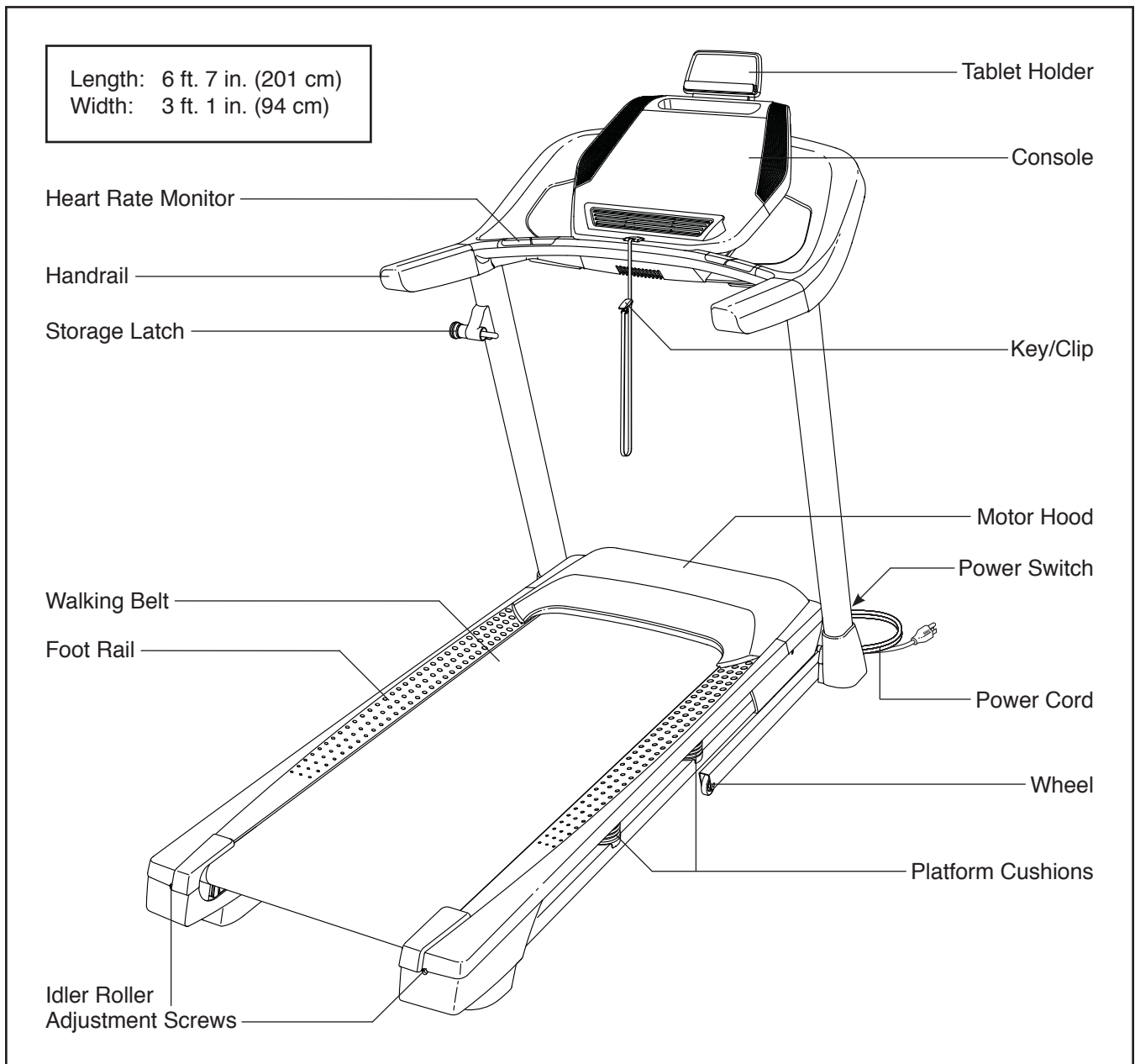

# PART IDENTIFICATION CHART

Use the drawings below to identify small parts used for assembly. The number in parentheses below each drawing is the key number of the part, from the PART LIST near the end of this manual. The number following the key number is the quantity used for assembly. **Note: If a part is not in the hardware kit, check to see whether it is preattached. Extra parts may be included.**

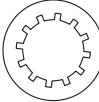
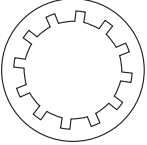
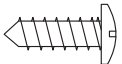
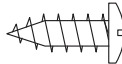
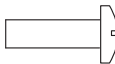
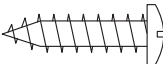
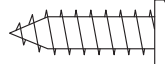
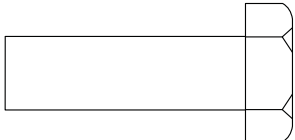
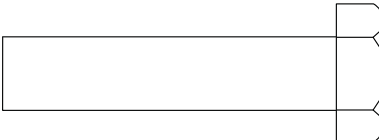
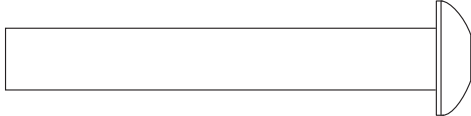
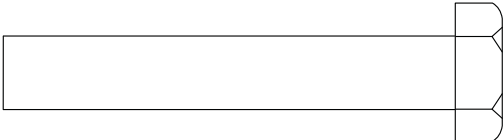
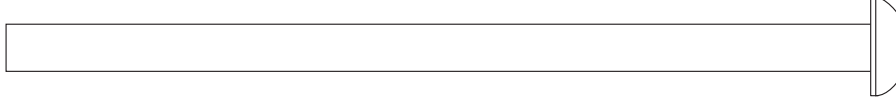
					
	1/4" Star Washer (26)–10	5/16" Star Washer (11)–4	3/8" Star Washer (13)–8		
					
#8 x 1/2" Ground Screw (18)–1	#8 x 1/2" Screw (1)–8	#8 x 1/2" Machine Screw (99)–4	#8 x 3/4" Screw (4)–8	#10 x 3/4" Screw (9)–4	
					
	3/8" x 1 1/4" Screw (51)–2	3/8" x 1 3/4" Screw (62)–2			
					
5/16" x 2 1/4" Screw (28)–4		3/8" x 2 3/8" Screw (7)–4			
					
	1/4" x 4 1/2" Screw (6)–2				

# ASSEMBLY

- To hire a service technician to assemble this product in your home, call 1-800-445-2480.
- Assembly requires two persons.
- Place all parts in a cleared area and remove the packing materials. Do not dispose of the packing materials until you finish all assembly steps.
- After shipping, there may be an oily substance on the exterior of the treadmill. This is normal. If there is an oily substance on the treadmill, wipe it off with a soft cloth and a mild, non-abrasive cleaner.

- Left parts are marked “L” or “Left” and right parts are marked “R” or “Right.”

- To identify small parts, see page 7.

- Assembly requires the following tools:

the included hex keys



one adjustable wrench



one Phillips screwdriver



To avoid damaging parts, do not use power tools.

1. **Go to [www.proformservice.com/](http://www.proformservice.com/) registration on your computer and register your product.**

- activates your warranty
- saves you time if you ever need to contact Customer Care
- allows us to notify you of upgrades and offers

Note: If you do not have Internet access, call Customer Care (see the front cover of this manual) and register your product.

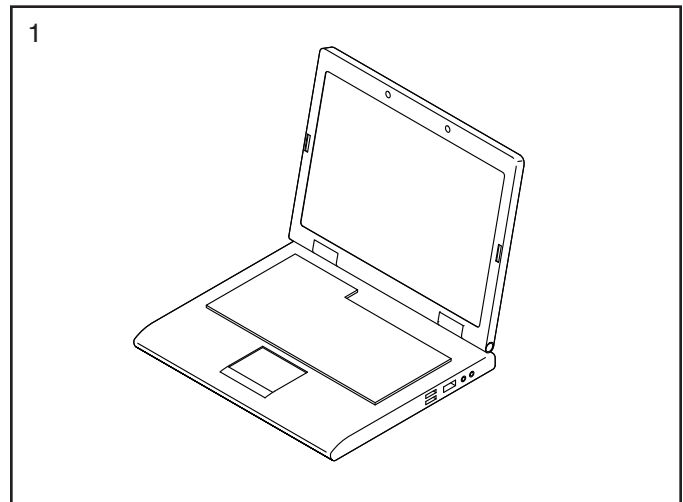

2. **Make sure that the power cord is unplugged.**

Remove the tie securing the Upright Wire (81) to the front of the Base (85).

Next, identify the Right Upright (90). Have a second person hold the Right Upright near the Base (85).

**See the inset drawing.** Tie the wire tie (A) in the Right Upright (90) securely around the end of the Upright Wire (81). Then, insert the Upright Wire into the lower end of the Right Upright as you pull the other end of the wire tie through the Right Upright.

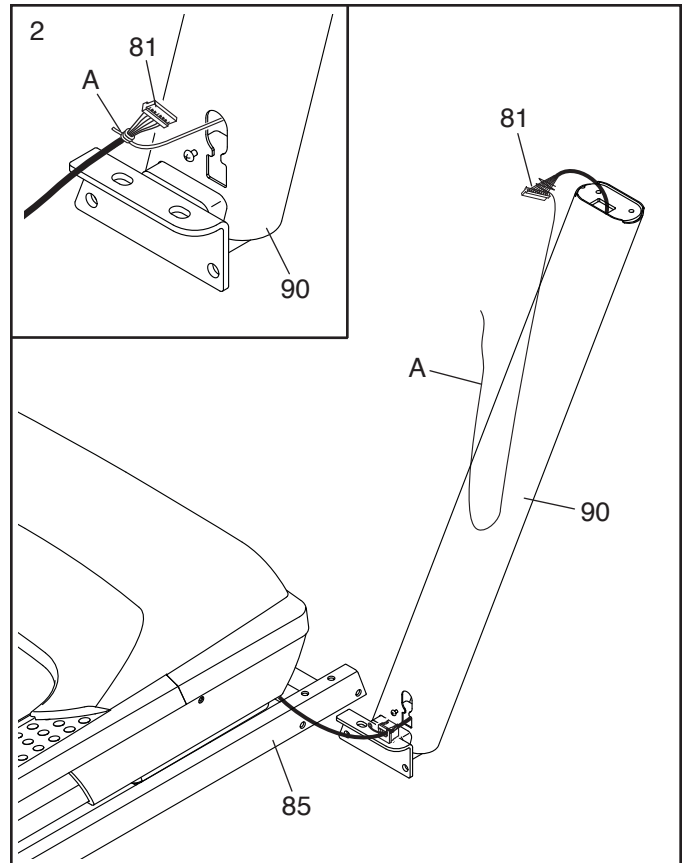

3. Lay the Right Upright (90) near the Base (85). Press the Grommet (77) into the square hole (B) in the Right Upright. **Make sure not to pinch the ground wire (C).**

Next, remove and discard the indicated screw (D).

Then, attach the ground wire to the Right Upright (90) with a #8 x 1/2" Ground Screw (18).

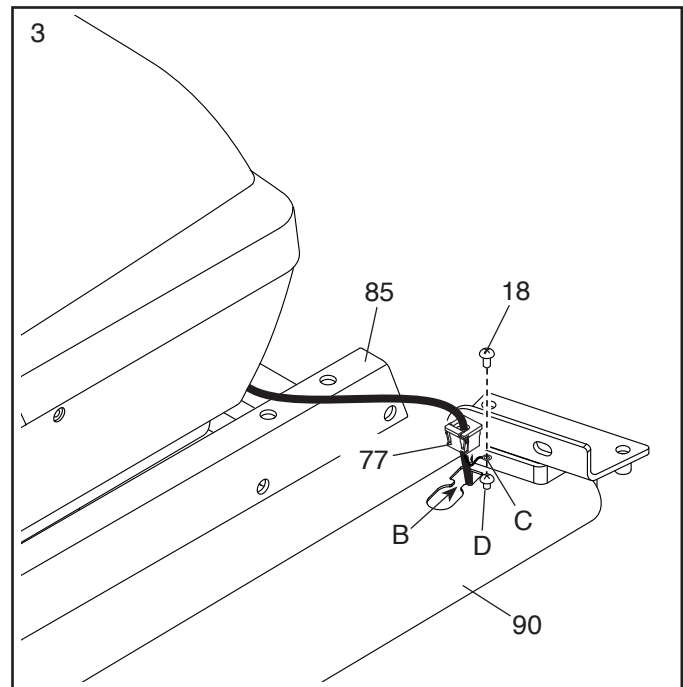

4. Hold the Right Upright (90) against the Base (85). **Make sure not to pinch the Upright Wire (81).**

Attach the Right Upright (90) with two 3/8" x 2 3/8" Screws (7), a 3/8" x 1 1/4" Screw (51), a 3/8" x 1 3/4" Screw (62), and four 3/8" Star Washers (13) as shown; **do not fully tighten the Screws yet.**

**Attach the Left Upright (not shown) in the same way.** Note: There are no wires on the left side.

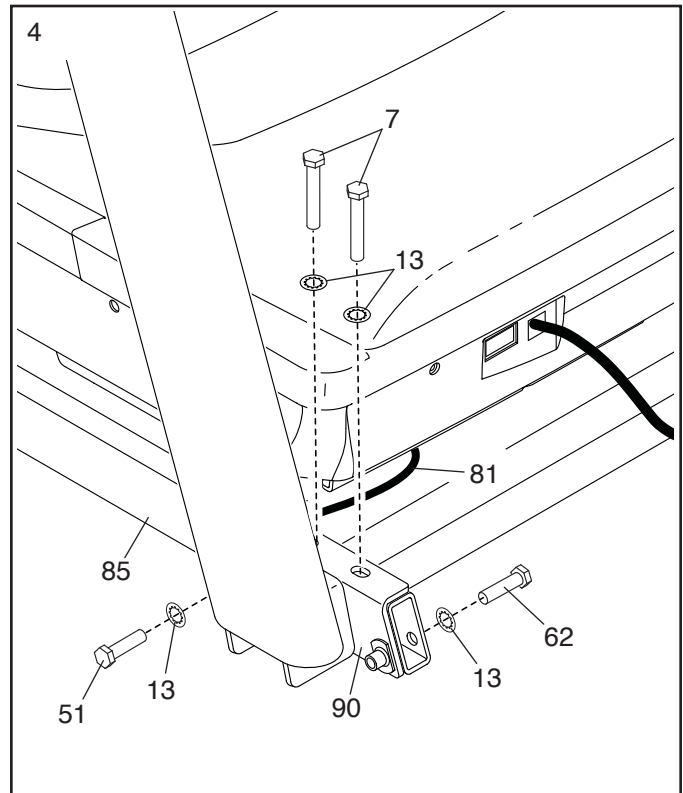

5. Identify the Left and Right Base Covers (82, 83). Slide the Left and Right Base Covers onto the Left and Right Uprights (89, 90) as shown.

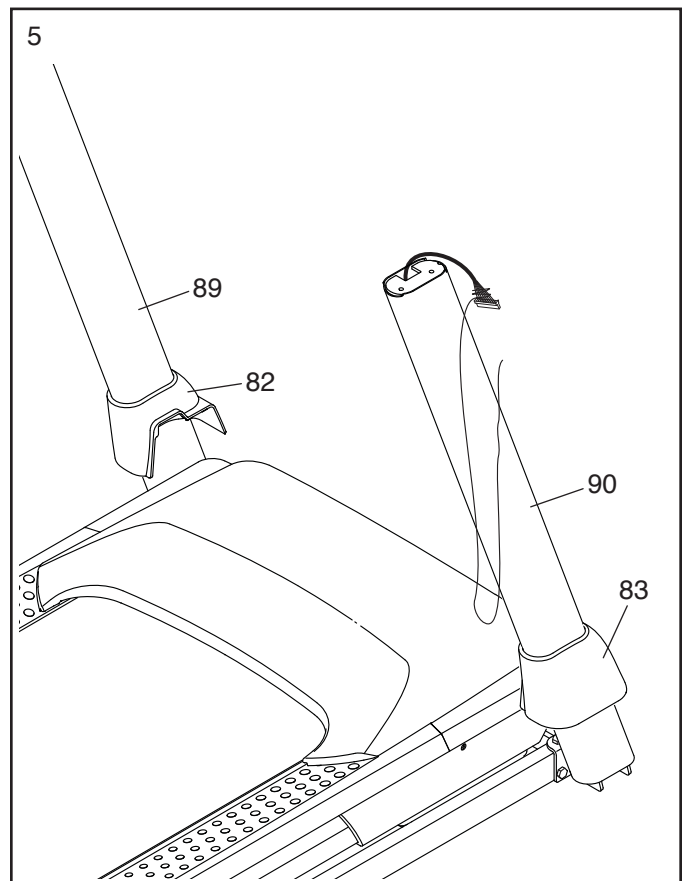

6. Set a Handrail (84) on the Right Upright (90). **Make sure that the Upright Wire (81) is not pinched.**

Attach the Handrail (84) with two 5/16" x 2 1/4" Screws (28) and two 5/16" Star Washers (11); **start both Screws, and then tighten them.**

**Attach the other Handrail (not shown) in the same way.** Note: There is no wire on the left side.

Then, remove the two indicated screws (E) from both Handrails (84) (only one side is shown). Discard the screws.

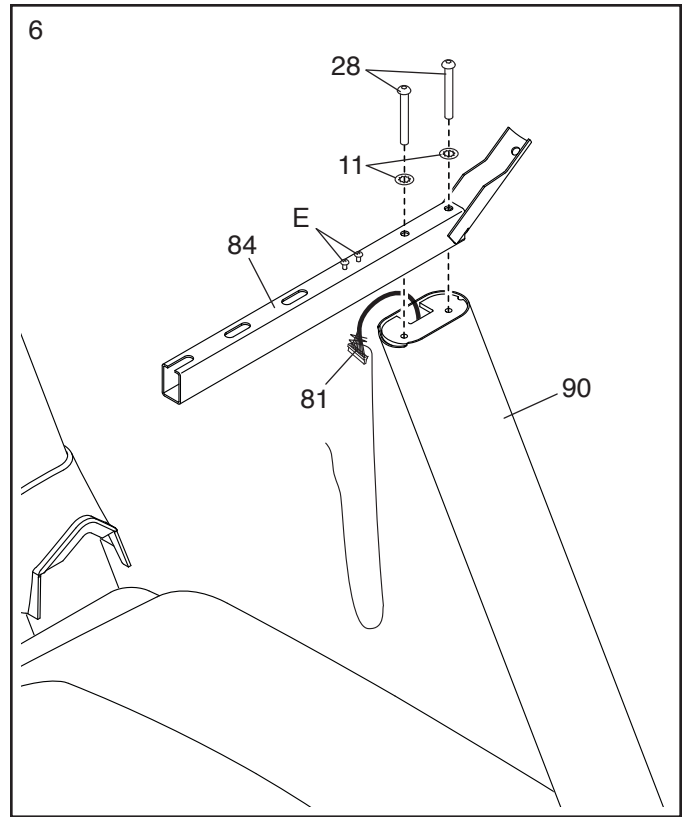

7. Set the console assembly (F) face down on a soft surface to avoid scratching the console assembly. **Remove and save the four 1/4" x 1/2" Screws (2).**

Identify the Left Tray (36). Attach the Left Tray with four #8 x 1/2" Screws (1); **start all four Screws, and then tighten them. Be careful not to overtighten the Screws.**

**Attach the Right Tray (27) in the same way.**

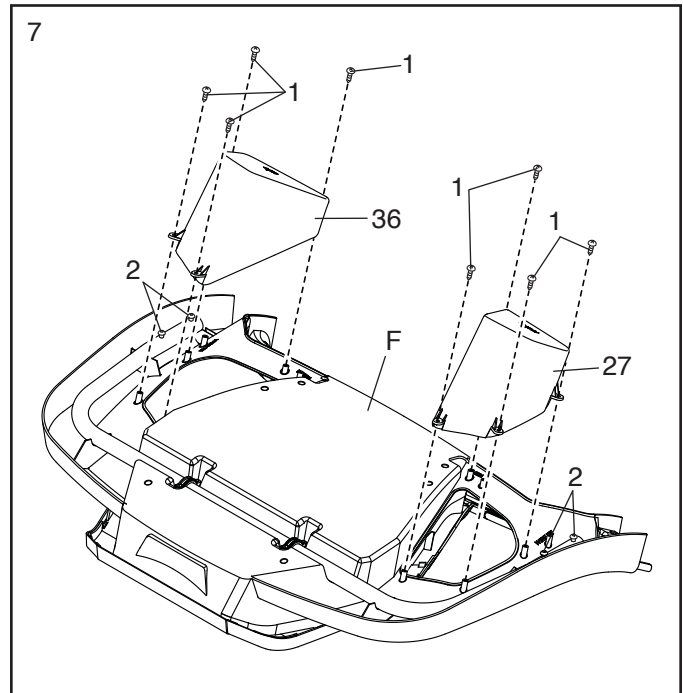

8. With the help of a second person, hold the console assembly (F) near the Right Handrail (84) and the Left Handrail (not shown).

**See the inset drawing.** Connect the Upright Wire (81) to the console wire (G). **The connectors should slide together easily and snap into place.** If they do not, turn one connector and try again. **IF YOU DO NOT CONNECT THE CONNECTORS PROPERLY, THE CONSOLE MAY BECOME DAMAGED WHEN YOU TURN ON THE POWER.** Then, remove the wire tie (A) from the Upright Wire.

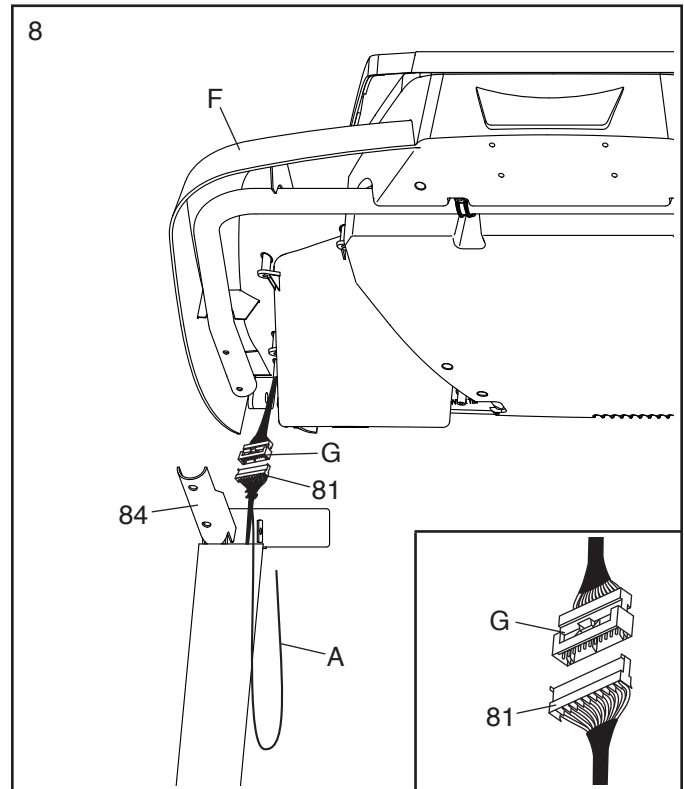

9. Set the console assembly (F) on the Handrails (84). **Be careful not to pinch any wires.** Insert the excess Upright Wire (81) into the Right Upright (90).

Attach the console assembly (F) with the four 1/4" x 1/2" Screws (2) that you removed in step 7 and four 1/4" Star Washers (26); **do not tighten the Screws yet.**

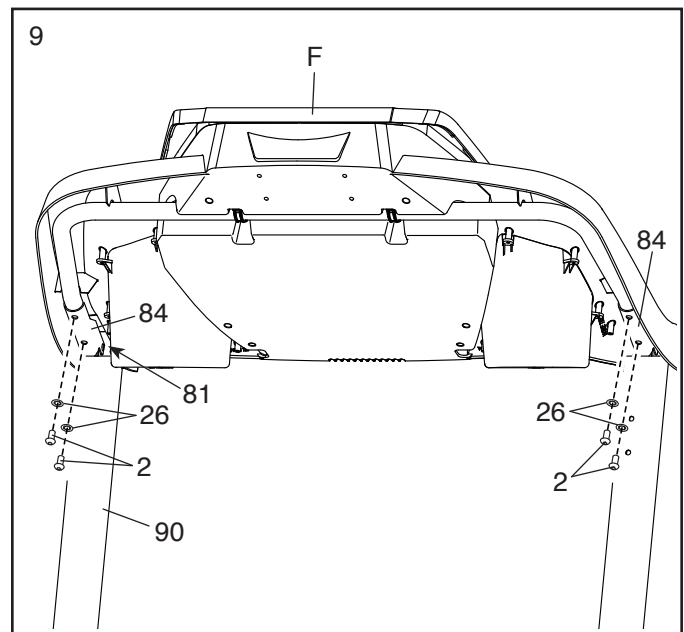

10. **IMPORTANT:** To avoid damaging the Pulse Crossbar (5), do not use power tools and do not overtighten the #10 x 3/4" Screws (9).

Tighten four #10 x 3/4" Screws (9) with four 1/4" Star Washers (26) into the Pulse Crossbar (5) and the left and right Handrails (84); **start all four Screws, and then tighten them.**

**See step 9.** Tighten the four 1/4" x 1/2" Screws (2).

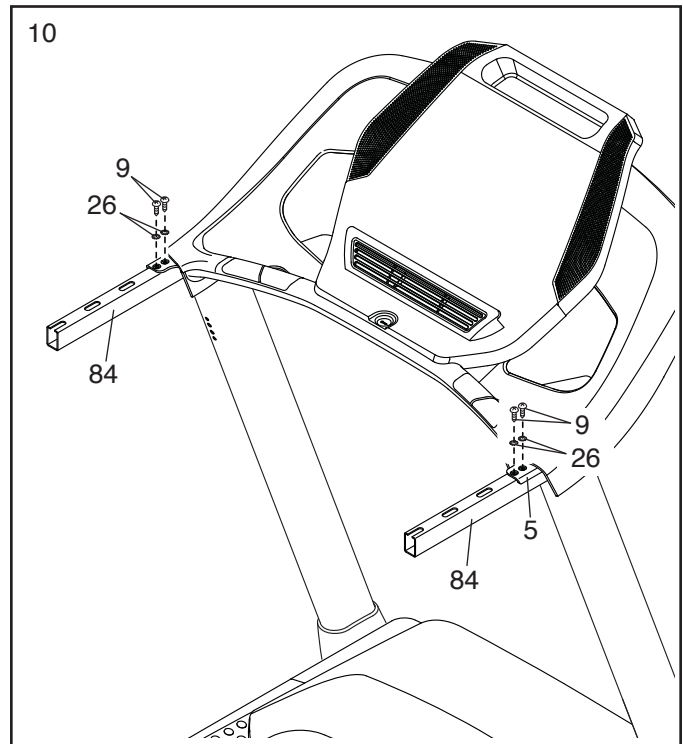

11. Identify the Left and Right Handrail Inserts (79, 31).

Attach the Left Handrail Insert (79) to the left Handrail (84) with three #8 x 3/4" Screws (4). **Note: Slide the Left Handrail Insert up against the console assembly (F) before you tighten the Screws.**

**Attach the Right Handrail Insert (31) in the same way.**

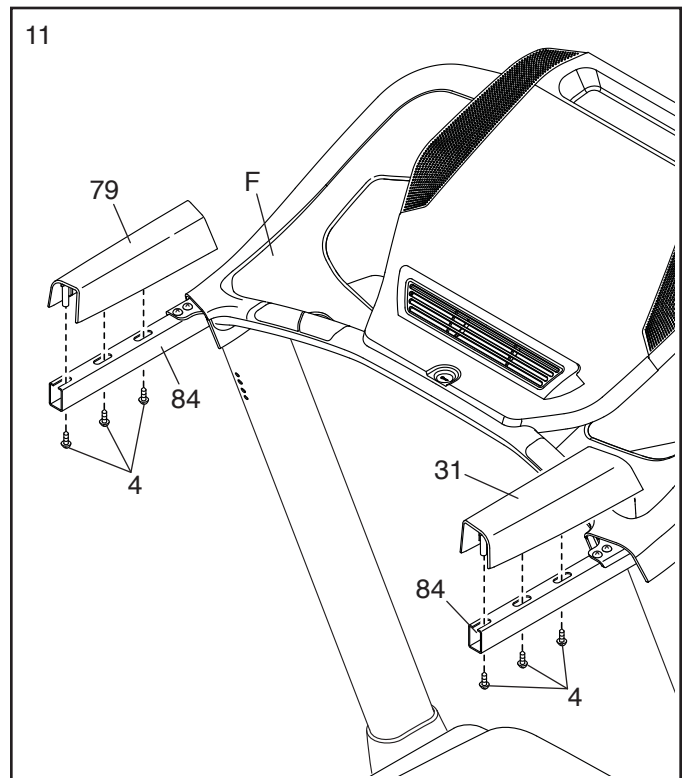

12. Identify the Left and Right Handrail Covers (87, 8).

Slide the Left Handrail Cover (87) up against the console assembly (F) and tighten a #8 x 3/4" Screw (4) into the bottom of the Left Handrail Cover. **Be careful not to overtighten the Screw.**

**Attach the Right Handrail Cover (8) in the same way.**

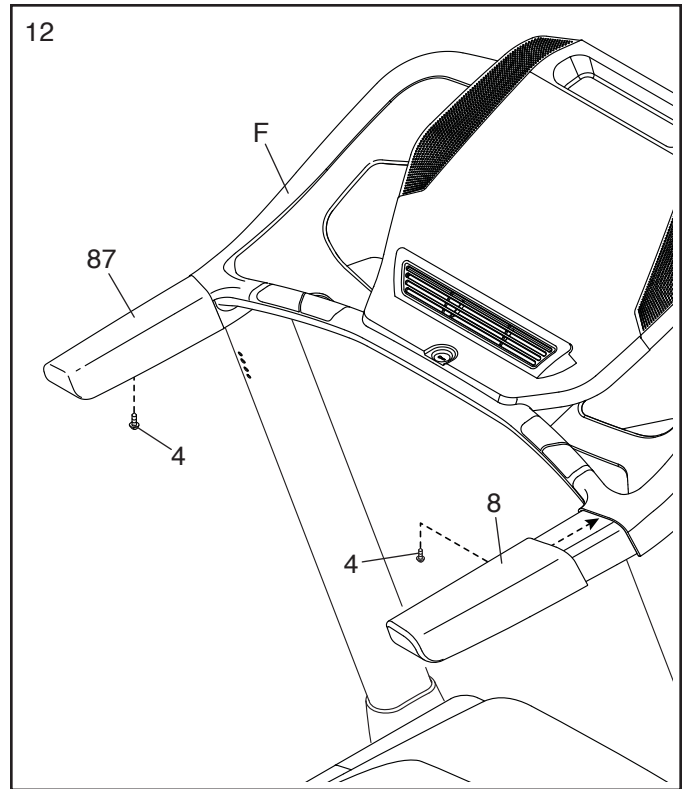

13. Orient the Storage Latch (98) as shown. Attach the Storage Latch to the Left Upright (89) with two 1/4" x 4 1/2" Screws (6) and two 1/4" Star Washers (26); **start both Screws, and then tighten them.**

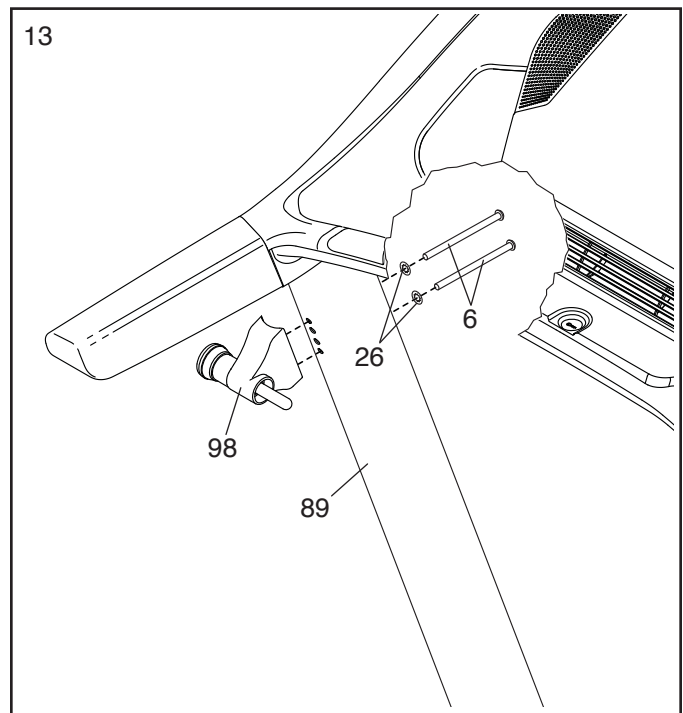

14. **Firmly tighten the four 3/8" x 2 3/8" Screws (7), the two 3/8" x 1 3/4" Screws (62), and the two 3/8" x 1 1/4" Screws (51).**

Next, set the Left Inner Base Cover (97) onto the lower end of the Left Upright (89). Then, slide the Left Base Cover (82) downward and press it onto the Left Inner Base Cover.

Next, set the Right Inner Base Cover (96) onto the lower end of the Right Upright (90). Then, slide the Right Base Cover (83) downward and press it onto the Right Inner Base Cover.

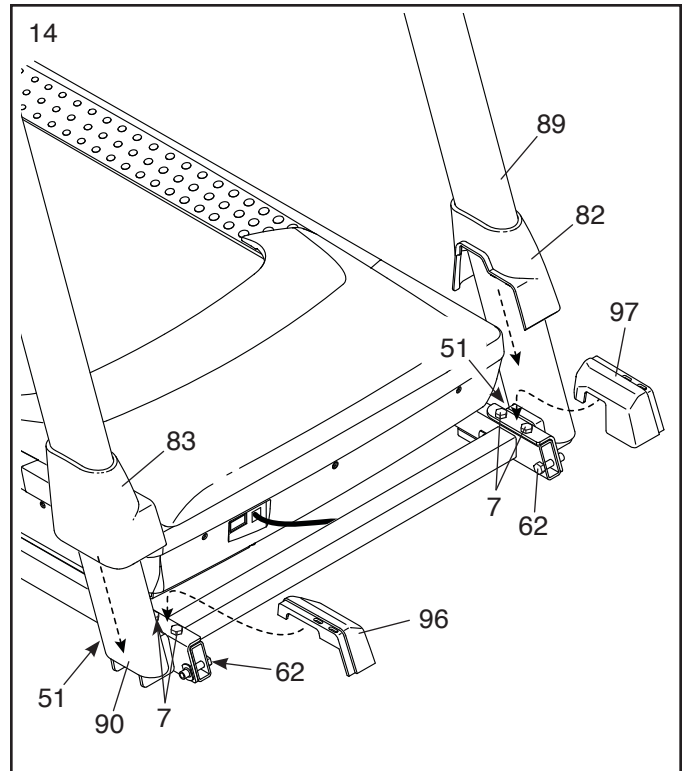

15. Attach the Tablet Holder (100) to the console assembly (F) with four #8 x 1/2" Machine Screws (99); **start all four Machine Screws, and then tighten them. Do not overtighten the Machine Screws.**

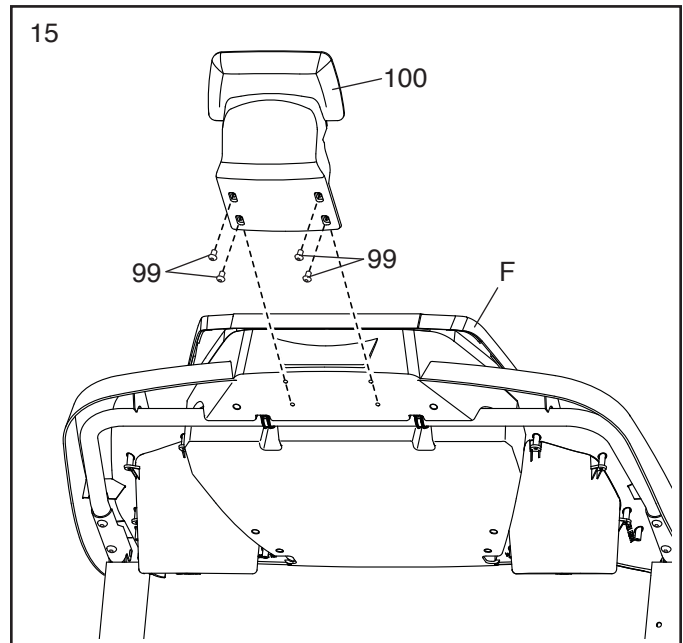

16. **Make sure that all parts are properly tightened before you use the treadmill.** If there are sheets of plastic on the treadmill decals, remove the plastic. To protect the floor or carpet, place a mat under the treadmill. To avoid damage to the console, keep the treadmill out of direct sunlight. Keep the included hex key in a secure place; the hex key is used to adjust the walking belt (see pages 27 and 28). Note: Extra hardware may be included.

# HOW TO USE THE TREADMILL

## HOW TO CONNECT THE POWER CORD

### Use a Surge Suppressor

Your treadmill, like other electronic equipment, can be damaged by sudden voltage changes in your home's power. Voltage surges, spikes, and noise interference can result from weather conditions or from other appliances being turned on or off. **To decrease the risk of damaging the treadmill, always use a surge suppressor with the treadmill. To purchase a surge suppressor, see precaution 14 on page 3.**

Use only a surge suppressor that is UL 1449 listed as a transient voltage surge suppressor (TVSS). The surge suppressor must have a UL suppressed voltage rating of 400 volts or less and a minimum surge dissipation of 450 joules. The surge suppressor must also be electrically rated for 120 volts AC and 15 amps. There must be a monitoring light on the surge suppressor to indicate whether it is functioning properly. **Failure to use a properly functioning surge suppressor could result in damage to the control system of the treadmill and serious injury to users.**

### Plug in the Power Cord

**The treadmill must be grounded.** If it should malfunction or break down, grounding provides a path of least resistance for electric current to reduce the risk of electric shock. The treadmill power cord has a plug with a grounding pin (see drawing 1 on this page).

**⚠ DANGER:** Improper connection of the power cord increases the risk of electric shock. Do not modify the plug—if it will not fit an outlet, have a proper outlet installed by a qualified electrician. If you are unsure whether the treadmill is properly grounded, contact a qualified electrician.

Plug the power cord into a surge suppressor, and plug the surge suppressor into an appropriate outlet that is properly installed and grounded in accordance with all local codes and ordinances. **The outlet must be on a nominal 120-volt circuit capable of carrying 15 or**

**more amps. To avoid overloading the circuit, do not plug other electrical devices, except for low-power devices such as cell phone chargers, into the surge suppressor or into an outlet on the same circuit. IMPORTANT: If the treadmill is connected to an AFCI-equipped outlet and your circuit breaker trips repeatedly when the treadmill is used, see the front cover of this manual to purchase an arc filter.**

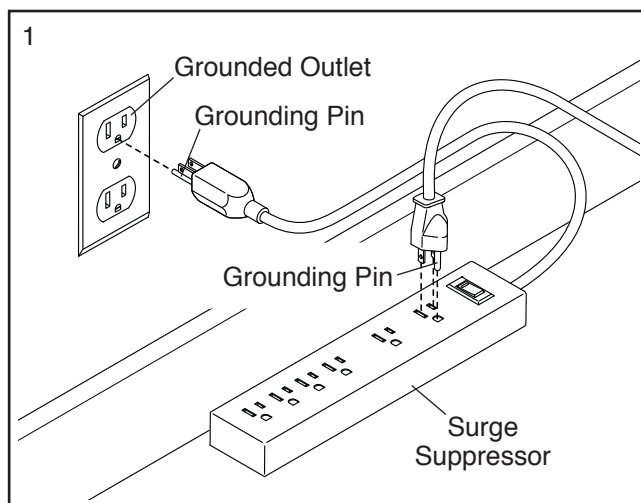

A temporary adapter may be used to connect the surge suppressor to a 2-pole receptacle if a properly grounded outlet is not available.

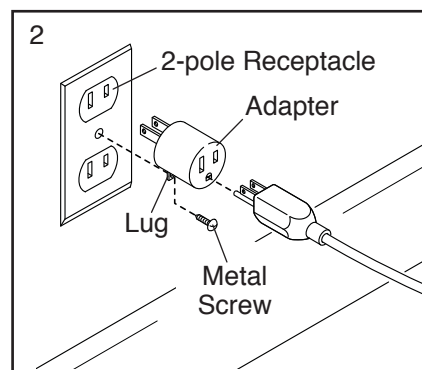

The lug or wire extending from the adapter must be connected with a metal screw to a permanent ground such as a properly grounded outlet box cover. **Some 2-pole receptacle outlet box covers are not grounded. Before using an adapter, contact a qualified electrician to determine whether the outlet box cover is grounded. The temporary adapter should be used only until a properly grounded outlet can be installed by a qualified electrician.**

## CONSOLE DIAGRAM

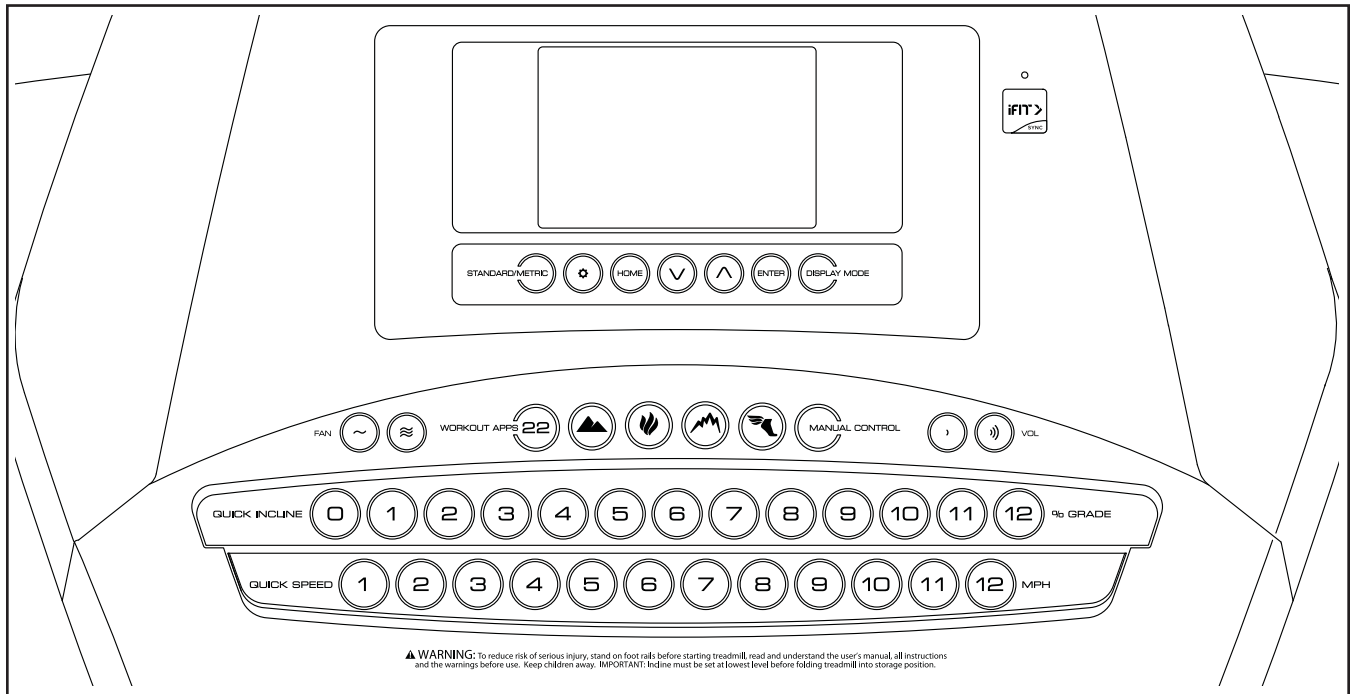

### FEATURES OF THE CONSOLE

The treadmill console offers a selection of features designed to make your workouts more effective and enjoyable. When you use the manual mode, you can change the speed and incline of the treadmill with the touch of a button. As you exercise, the console will display instant exercise feedback. You can even measure your heart rate using the handgrip heart rate monitor or a compatible heart rate monitor. **See page 22 for information about purchasing an optional chest heart rate monitor.**

In addition, the console features a selection of onboard workouts. Each workout automatically controls the speed and incline of the treadmill as it guides you through an effective exercise session.

You can also connect your smart device to the console and use an iFit® app to record and track your workout information.

You can even listen to your favorite workout music or audio books with the console's sound system while you exercise.

**To turn on the power**, see page 18. **To use the manual mode**, see page 18. **To use an onboard workout**, see page 20. **To connect your smart device to the console**, see page 22. **To connect your heart rate monitor to the console**, see page 22. **To use the settings mode**, see page 23. **To use the sound system**, see page 23.

Note: The console can display speed and distance in either miles or kilometers. To change which unit of measurement is selected, press the Standard/Metric button. For simplicity, all instructions in this section refer to miles.

**IMPORTANT: If there are sheets of plastic on the console, remove the plastic. To prevent damage to the walking platform, wear clean athletic shoes while using the treadmill. The first time you use the treadmill, observe the alignment of the walking belt, and center the walking belt if necessary (see page 27).**

## HOW TO TURN ON THE POWER

**IMPORTANT:** If the treadmill has been exposed to cold temperatures, allow it to warm to room temperature before you turn on the power. If you do not do this, you may damage the console displays or other electrical components.

Plug in the power cord (see page 16). Next, locate the power switch on the treadmill frame near the power cord. Press the power switch into the reset position.

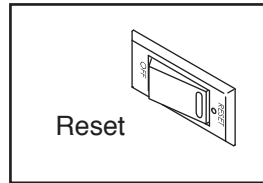

Next, stand on the foot rails of the treadmill. Find the clip attached to the key and slide the clip onto the waistband of your clothes. Then, insert the key into the console. After a moment, the displays will light. **IMPORTANT:** In an emergency, the key can be pulled from the console, causing the walking belt to slow to a stop. Test the clip by carefully taking a few steps backward; if the key is not pulled from the console, adjust the position of the clip.

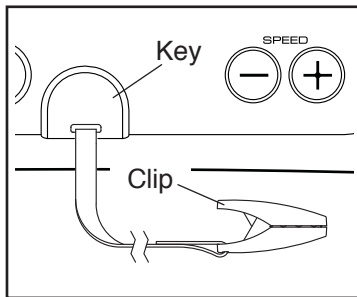

**IMPORTANT:** Before you use the treadmill, take the following steps to ensure that the console shows the correct incline level of the treadmill: First, press the Incline increase button once. Next, press either the Incline decrease button or the lowest Quick Incline button to set the treadmill to its lowest setting. When the frame stops moving, the treadmill is ready for use.

## HOW TO USE THE MANUAL MODE

### 1. Insert the key into the console.

See HOW TO TURN ON THE POWER at the left.

### 2. Select the manual mode.

If the manual mode is not selected, press the Manual Control button on the console.

### 3. Start the walking belt.

To start the walking belt, press the Run button or one of the Quick Speed buttons.

If you press the Run button the walking belt will begin to move at 1 mph. As you exercise, change the speed of the walking belt as desired by pressing the Speed increase and decrease buttons. Each time you press one of the buttons, the speed setting will change by 0.1 mph; if you hold down the button, the speed setting will change in increments of 0.5 mph. Note: After you press the button, it may take a moment for the walking belt to reach the selected speed setting.

If you press one of the Quick Speed buttons, the walking belt will gradually change speed until it reaches the selected speed setting. To select a speed setting that includes a decimal—such as 3.5 mph—press two numbered buttons in succession. For example, to select a speed setting of 3.5 mph, press the 3 button and then immediately press the 5 button. Note: This feature will not function if the console is set to metric units.

To stop the walking belt, press the Stop button. The time will begin to flash in the display. To restart the walking belt, press the Run button.

#### 4. Change the incline of the treadmill as desired.

To change the incline of the treadmill, press the Incline increase or decrease button or one of the Quick Incline buttons. Each time you press one of the buttons, the treadmill will gradually adjust to the selected incline setting.

#### 5. Follow your progress with the displays.

As you walk or run on the treadmill, the display can show the following workout information:

- The elapsed time
- The distance that you have walked or run
- The workout intensity bar
- The approximate number of calories you have burned
- The incline level of the treadmill
- The number of vertical feet you have climbed
- The speed of the walking belt
- Your heart rate (see step 6 on page 20)
- The matrix

The matrix offers several display tabs. Press the Display Mode button until the desired tab is shown.

The Incline tab will show a profile of the incline settings of the workout. A new segment will appear at the end of each minute. The Speed tab will show a profile of the speed settings of the workout.

The My Trail tab will show a track that represents 1/4 mile (400 m). As you exercise, the flashing rectangle will show your progress. The My Trail tab will also show the number of laps you complete.

The Calorie tab will show the approximate amount of calories you have burned. The height of each segment represents the amount of calories burned during that segment. When the Calorie tab is selected, the calorie display will show the approximate number of calories burned per hour.

As you exercise, the workout intensity level bar will indicate the approximate intensity level of your exercise.

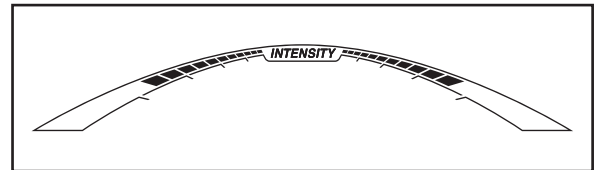

Press the Home button to return to the default menu (see THE SETTINGS MODE on page 23 to set the default menu). If necessary, press the Home button again.

To reset the displays, press the Stop button repeatedly.

## 6. Measure your heart rate if desired.

You can measure your heart rate using either the handgrip heart rate monitor or a compatible heart rate monitor. **For information about purchasing an optional chest heart rate monitor, see page 22.**

The console is compatible with all BLUETOOTH® Smart heart rate monitors. To connect your heart rate monitor to the console, see page 22.

**Note: If you use both heart rate monitors at the same time, the BLUETOOTH Smart heart rate monitor will have priority.**

Before using the handgrip heart rate monitor, remove the sheets of plastic from the metal contacts on the pulse bar. In addition, make sure that your hands are clean.

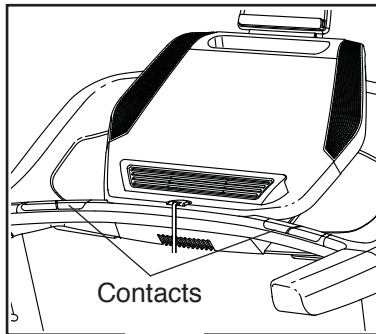

To measure your heart rate, **stand on the foot rails** and hold the pulse bar with your palms on the metal contacts; **avoid moving your hands**. When your pulse is detected, your heart rate will be shown. **For the most accurate heart rate reading, continue to hold the metal contacts for about 15 seconds.**

## 7. Turn on the fan if desired.

The fan features several speed settings. Press the fan buttons repeatedly to select a fan speed or to turn on or turn off the fan.

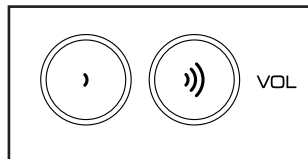

## 8. When you are finished exercising, remove the key from the console.

When you are finished using the treadmill, step onto the foot rails, press the Stop button, and **adjust the incline of the treadmill to zero. The incline must be at zero or you may damage the treadmill when you fold it to the storage position.** Next, remove the key from the console and put it in a secure place.

Then, press the power switch into the off position and unplug the power cord. **IMPORTANT: If you do not do this, the treadmill's electrical components may wear prematurely.**

## HOW TO USE AN ONBOARD WORKOUT

### 1. Insert the key into the console.

See HOW TO TURN ON THE POWER on page 18.

### 2. Select an onboard workout.

To select an onboard workout, press the Incline button, the Calorie button, the Intensity button, or the Speed button repeatedly until the desired workout appears in the display.

When you select an onboard workout, the display will show the duration of the workout and the name of the workout. In addition, a profile of the speed settings of the workout will appear in the matrix. If you select a calorie workout, the approximate number of calories you will burn will appear in the calorie window.

### 3. Start the workout.

Press the Run button to start the workout. A moment after you press the button, the treadmill will automatically adjust to the first speed and incline settings of the workout. Hold the handrails and begin walking.

Each workout is divided into segments. One speed setting and one incline setting are programmed for each segment. Note: The same speed setting and/or incline setting may be programmed for consecutive segments.

During the workout, the profiles on the speed and incline tabs will show your progress. The flashing segment of the profile represents the current segment of the workout.

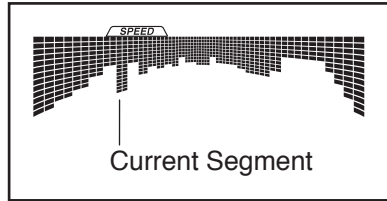

The height of the flashing segment indicates the speed or incline setting for the current segment. At the end of each segment, a series of tones will sound and the next segment of the profile will begin to flash. If a different speed and/or incline setting is programmed for the next segment, the speed and/or incline setting will flash in the display to alert you and the treadmill will automatically adjust to the new speed and/or incline setting.

The workout will continue in this way until the last segment of the profile flashes in the display and the last segment ends. The walking belt will then slow to a stop.

**Note: The calorie goal is an estimate of the number of calories that you will burn during the workout. The actual number of calories that you burn will depend on various factors such as your weight. In addition, if you manually change the speed or incline of the treadmill during the workout, the number of calories you burn will be affected.**

If the speed or incline setting is too high or too low at any time during the workout, you can manually override the setting by pressing the Speed or Incline buttons; **however, when the next segment of the workout begins, the treadmill will automatically adjust to the speed and incline settings for the next segment.**

To stop the workout at any time, press the Stop button. The time will begin to flash in the display. To resume the workout, press the Run button. The walking belt will begin to move at 1 mph. When the next segment of the workout begins, the treadmill will automatically adjust to the speed and incline settings for the next segment.

#### 4. Follow your progress with the displays.

See step 5 on page 19. If you select an onboard workout, the display will show the time remaining or the calories remaining instead of the elapsed time.

#### 5. Measure your heart rate if desired.

See step 6 on page 20.

#### 6. Turn on the fan if desired.

See step 7 on page 20.

#### 7. When you are finished exercising, remove the key from the console.

See step 8 on page 20.

## HOW TO CONNECT YOUR SMART DEVICE TO THE CONSOLE

### 1. Download and install the iFit app on your smart device.

On your IOS® or Android™ smart device, open the App Store<sup>SM</sup> or the Google Play™ store, search for the free iFit app, and then install the app on your smart device. **Make sure that the BLE option is enabled on your smart device.**

Then, open the iFit app and follow the instructions to set up an iFit account and customize settings.

### 2. Connect your smart device to the console.

Follow the instructions in the iFit app to connect your smart device to the console.

When a connection is established, the LED on the console will flash. Press the iFit Sync button on the console to confirm the connection.

### 3. Record and track your workout information.

Follow the instructions in the iFit app to record and track your workout information.

### 4. Disconnect your smart device from the console if desired.

To disconnect your smart device from the console, press and hold the iFit Sync button on the console for 5 seconds.

Note: All BLUETOOTH connections between the console and other devices (including any smart devices, heart rate monitors, and so forth) will be disconnected.

## THE OPTIONAL CHEST HEART RATE MONITOR

Whether your goal is to burn fat or to strengthen your cardiovascular system, the key to achieving the best results is to maintain the proper heart rate during your workouts.

The optional chest heart rate monitor will enable you to continuously monitor your heart rate while you exercise, helping you to reach your personal fitness goals. **To purchase a chest heart rate monitor, please see the front cover of this manual.**

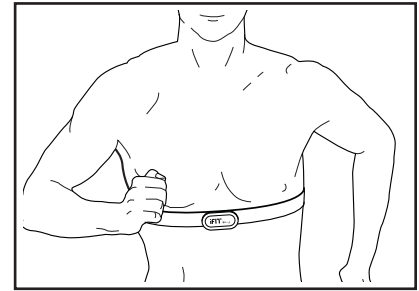

Note: The console is compatible with all BLUETOOTH Smart heart rate monitors.

## HOW TO CONNECT YOUR HEART RATE MONITOR TO THE CONSOLE

The console is compatible with all BLUETOOTH Smart heart rate monitors.

To connect your BLUETOOTH Smart heart rate monitor to the console, press the iFit Sync button on the console. The LED on the console will flash twice once the connection is successful. Note: This may take up to 15 seconds.

Note: If there is more than one compatible heart rate monitor near the console, the console will connect to the heart rate monitor with the strongest signal.

To disconnect your heart rate monitor from the console, press and hold the iFit Sync button on the console for 5 seconds.

Note: All BLUETOOTH connections between the console and other devices (including any smart devices, heart rate monitors, and so forth) will be disconnected.

## THE SETTINGS MODE

The console features an information mode that keeps track of treadmill information and allows you to personalize console settings.

### 1. Select the information mode.

To select the settings mode, press the settings button. When the settings mode is selected, the display will show the total number of hours that the treadmill has been used and the total number of miles (or kilometers) that the walking belt has moved.

### 2. Select the optional screens.

While the information mode is selected, the matrix will display several optional screens. Press the increase button next to the Enter button to select each of the following screens:

**INCLINE CALIBRATION**—To calibrate the incline system of the treadmill, press the Incline increase or decrease buttons. The treadmill will automatically rise to the maximum incline level and then return to the minimum level.

**UNITS**—Press the Incline increase and decrease buttons to change which unit of measurement is displayed on the console.

**CONTRAST LVL**—Press the Incline increase and decrease buttons to adjust the contrast level of the display.

Press the decrease button next to the Enter button to return to the previous screen.

### 3. Exit the settings mode.

To exit the settings mode, remove the key from the console.

## HOW TO USE THE SOUND SYSTEM

To play music or audio books through the console sound system while you exercise, plug a 3.5 mm male to 3.5 mm male audio cable (not included) into the jack on the console and into a jack on your personal audio player; **make sure that the audio cable is fully plugged in. Note: To purchase an audio cable, see your local electronics store.**

Next, press the play button on your personal audio player. Adjust the volume level using the volume increase and decrease buttons on the console or the volume control on your personal audio player.

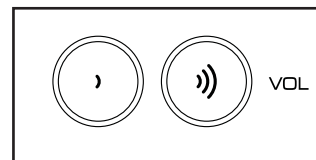

---

## FCC INFORMATION

This console has been tested and found to comply with the limits for a Class B digital device, pursuant to part 15 of the FCC Rules. These limits are designed to provide reasonable protection against harmful interference in a residential installation. This equipment generates, uses, and can radiate radio frequency energy and, if not installed and used in accordance with the instructions, may cause harmful interference to radio communications. However, there is no guarantee that interference will not occur in a particular installation. If this equipment does cause harmful interference to radio or television reception, which can be determined by turning the equipment off and on, try to correct the interference by one or more of the following measures:

- Reorient or relocate the receiving antenna.
- Increase the separation between the equipment and the receiver.
- Connect the equipment into an outlet on a circuit different from that to which the receiver is connected.
- Consult the dealer or an experienced radio/TV technician for help.

**FCC CAUTION: To assure continued compliance, use only shielded interface cables when connecting to computer or peripheral devices. Changes or modifications not expressly approved by the party responsible for compliance could void the user's authority to operate this equipment.**

**IMPORTANT: To satisfy exposure compliance requirements, the antenna and transmitter in the console must be at least 8 in. (20 cm) from all persons and must not be near or connected to any other antenna or transmitter.**

**Note: The console contains either FCC ID: OMCBBICON14 or FCC ID: OMCBMD1.**

# HOW TO FOLD AND MOVE THE TREADMILL

## HOW TO FOLD THE TREADMILL

To avoid damaging the treadmill, adjust the incline to zero before you fold the treadmill. Then, remove the key and unplug the power cord. **CAUTION:** You must be able to safely lift 45 lbs. (20 kg) to raise, lower, or move the treadmill.

1. Hold the metal frame firmly in the location shown by the arrow below. **CAUTION: Do not hold the frame by the plastic foot rails. Bend your legs and keep your back straight as you raise the frame about halfway to the vertical position.**

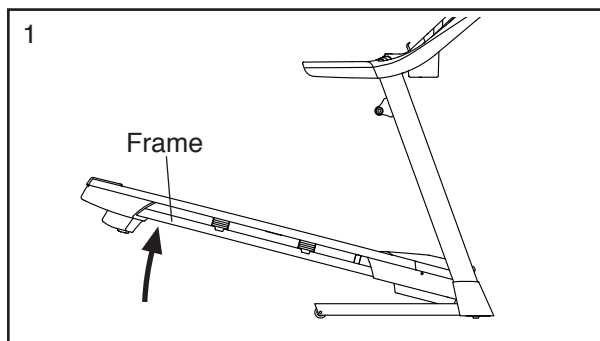

2. Hold the frame firmly with your right hand. Pull the latch knob to the left and hold it. Raise the frame until the latch plate is aligned with the latch pin. Then, slowly release the latch knob; **make sure that the latch pin is resting on the latch plate.**

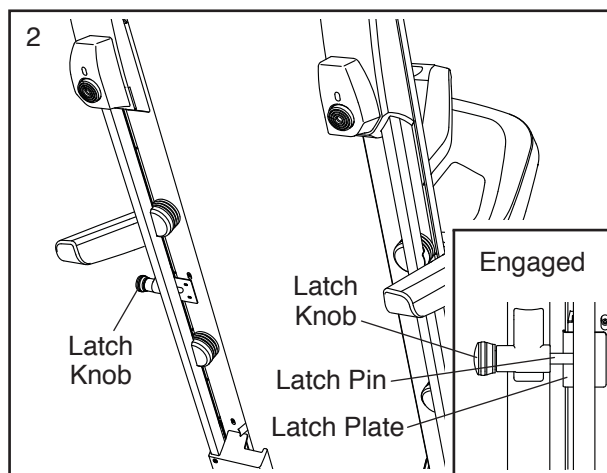

To protect the floor or carpet, place a mat under the treadmill. Keep the treadmill out of direct sunlight. Do not leave the treadmill in the storage position in temperatures above 85°F (30°C).

## HOW TO MOVE THE TREADMILL

Before moving the treadmill, fold it as described at the left. **CAUTION: Make sure that the latch knob is locked in the storage position. Moving the treadmill may require two people.**

1. Hold the frame and one of the handrails, and place one foot against a wheel.

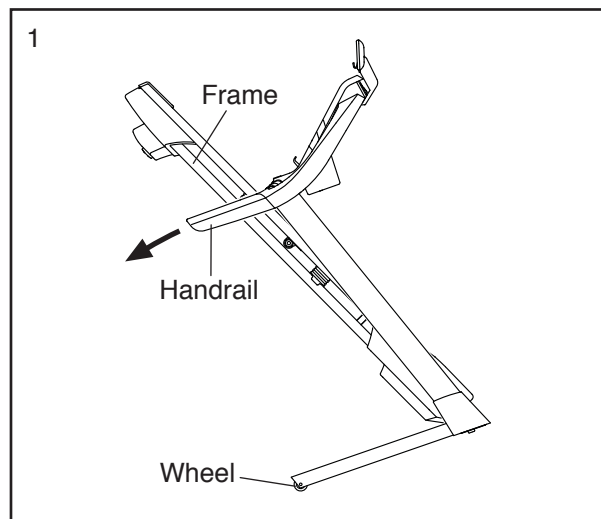

2. Pull back on the handrail until the treadmill will roll on the wheels, and carefully move it to the desired location. **CAUTION: Do not move the treadmill without tipping it back, do not pull on the frame, and do not move the treadmill over an uneven surface.**
3. Place one foot against a wheel, and carefully lower the treadmill.

## HOW TO LOWER THE TREADMILL FOR USE

1. **See drawing 2.** Hold the upper end of the treadmill with your right hand. Pull the latch knob to the left and hold it. Next, lower the frame until it is past the latch pin. Make sure that the pin does not hit against the foot rail. Then, release the latch knob.
2. **See drawing 1 at the left.** Hold the metal frame firmly with both hands, and lower it to the floor. **CAUTION: Do not hold the frame by the plastic foot rails, and do not drop the frame. Bend your legs and keep your back straight.**

# MAINTENANCE AND TROUBLESHOOTING

## MAINTENANCE

Regular maintenance is important for optimal performance and to reduce wear. Inspect and properly tighten all parts each time the treadmill is used.

Regularly clean the treadmill and keep the walking belt clean and dry. First, **press the power switch into the off position and unplug the power cord.** Wipe exterior parts of the treadmill with a damp cloth and a small amount of mild soap. **IMPORTANT: Do not spray liquids directly onto the treadmill. To avoid damage to the console, keep liquids away from the console.** Then, thoroughly dry the treadmill with a soft towel.

## TROUBLESHOOTING

### SYMPTOM: The power does not turn on

- Make sure that the power cord is plugged into a surge suppressor and that the surge suppressor is plugged into a properly grounded outlet (see page 16). Use only a surge suppressor that meets all of the specifications described on page 16. **IMPORTANT: If the treadmill is connected to an AFCI-equipped outlet and your circuit breaker trips repeatedly when the treadmill is used, see the front cover of this manual to purchase an arc filter.**
- After the power cord has been plugged in, make sure that the key is inserted into the console.

- Check the power switch located on the treadmill frame near the power cord. If the switch protrudes as shown, the switch has tripped. To reset the power switch, wait for five minutes and then press the switch back in.

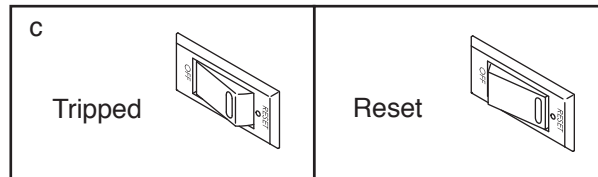

### SYMPTOM: The power turns off during use

- Check the power switch (see the drawing above). If the switch has tripped, wait for five minutes and then press the switch back in.
- Make sure that the power cord is plugged in. If the power cord is plugged in, unplug it, wait for five minutes, and then plug it back in.
- Remove the key from the console, and then reinsert it.
- If the treadmill still will not run, please see the front cover of this manual.

### SYMPTOM: The console displays remain lit when you remove the key from the console

- The console features a display demo mode, designed to be used if the treadmill is displayed in a store. If the displays remain lit when you remove the key, the demo mode is turned on. To turn off the demo mode, hold down the Stop button for a few seconds. If the displays are still lit, see THE SETTINGS MODE on page 23 to turn off the demo mode.

**SYMPTOM: The incline of the treadmill does not change correctly**

- a. See step 2 on page 23 to calibrate the incline system.

**SYMPTOM: The walking belt slows when walked on**

- a. Use only a surge suppressor that meets all of the specifications described on page 16.
- b. If the walking belt is overtightened, treadmill performance may decrease and the walking belt may become damaged. Remove the key and **UNPLUG THE POWER CORD**. Using the hex key, turn both idler roller screws counterclockwise, 1/4 of a turn. When the walking belt is properly tightened, you should be able to lift each edge of the walking belt 2 to 3 in. (5 to 7 cm) off the walking platform. Be careful to keep the walking belt centered. Then, plug in the power cord, insert the key, and run the treadmill for a few minutes. Repeat until the walking belt is properly tightened.

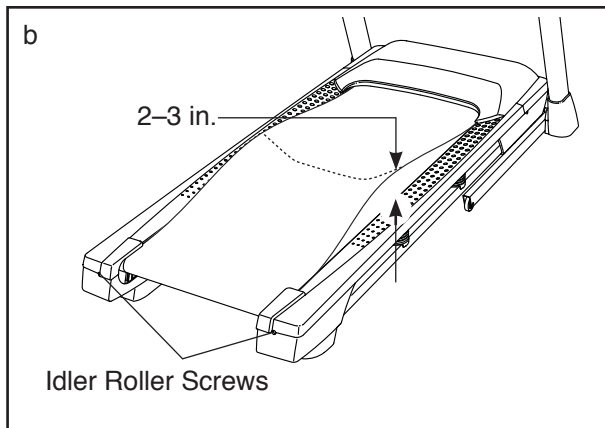

- c. Your treadmill features a walking belt coated with high-performance lubricant. **IMPORTANT: Never apply silicone spray or other substances to the walking belt or the walking platform unless instructed to do so by an authorized service representative. Such substances may deteriorate the walking belt and cause excessive wear.** If you suspect that the walking belt needs more lubricant, see the front cover of this manual.
- d. If the walking belt still slows when walked on, see the front cover of this manual.

**SYMPTOM: The walking belt is off-center or slips when walked on**

- a. **If the walking belt is off-center**, first remove the key and **UNPLUG THE POWER CORD**. **If the walking belt has shifted to the left**, use the hex key to turn the left idler roller screw clockwise 1/2 of a turn; **if the walking belt has shifted to the right**, turn the left idler roller screw counterclockwise 1/2 of a turn. Be careful not to overtighten the walking belt. Then, plug in the power cord, insert the key, and run the treadmill for a few minutes. Repeat until the walking belt is centered.

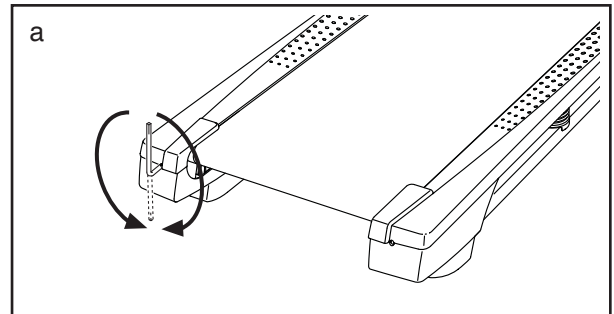

- b. **If the walking belt slips when walked on**, first remove the key and **UNPLUG THE POWER CORD**. Using the hex key, turn both idler roller screws clockwise, 1/4 of a turn. When the walking belt is correctly tightened, you should be able to lift each edge of the walking belt 2 to 3 in. (5 to 7 cm) off the walking platform. Be careful to keep the walking belt centered. Then, plug in the power cord, insert the key, and carefully walk on the treadmill for a few minutes. Repeat until the walking belt is properly tightened.

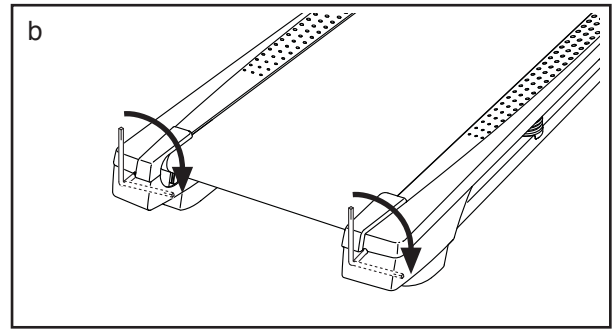

# EXERCISE GUIDELINES

**⚠️ WARNING:** Before beginning this or any exercise program, consult your physician. This is especially important for persons over age 35 or persons with pre-existing health problems.

The heart rate monitor is not a medical device. Various factors may affect the accuracy of heart rate readings. The heart rate monitor is intended only as an exercise aid in determining heart rate trends in general.

These guidelines will help you to plan your exercise program. For detailed exercise information, obtain a reputable book or consult your physician. Remember, proper nutrition and adequate rest are essential for successful results.

## EXERCISE INTENSITY

Whether your goal is to burn fat or to strengthen your cardiovascular system, exercising at the proper intensity is the key to achieving results. You can use your heart rate as a guide to find the proper intensity level. The chart below shows recommended heart rates for fat burning and aerobic exercise.

165	155	145	140	130	125	115	❤️
145	138	130	125	118	110	103	❤️
125	120	115	110	105	95	90	❤️
<hr/>							
20	30	40	50	60	70	80	

To find the proper intensity level, find your age at the bottom of the chart (ages are rounded off to the nearest ten years). The three numbers listed above your age define your “training zone.” The lowest number is the heart rate for fat burning, the middle number is the heart rate for maximum fat burning, and the highest number is the heart rate for aerobic exercise.

**Burning Fat**—To burn fat effectively, you must exercise at a low intensity level for a sustained period of time. During the first few minutes of exercise, your body uses carbohydrate calories for energy. Only after the first few minutes of exercise does your body begin to use stored fat calories for energy. If your goal is to burn fat, adjust the intensity of your exercise until your heart rate is near the lowest number in your training zone. For maximum fat burning, exercise with your heart rate near the middle number in your training zone.

**Aerobic Exercise**—If your goal is to strengthen your cardiovascular system, you must perform aerobic exercise, which is activity that requires large amounts of oxygen for prolonged periods of time. For aerobic exercise, adjust the intensity of your exercise until your heart rate is near the highest number in your training zone.

## WORKOUT GUIDELINES

**Warming Up**—Start with 5 to 10 minutes of stretching and light exercise. A warm-up increases your body temperature, heart rate, and circulation in preparation for exercise.

**Training Zone Exercise**—Exercise for 20 to 30 minutes with your heart rate in your training zone. (During the first few weeks of your exercise program, do not keep your heart rate in your training zone for longer than 20 minutes.) Breathe regularly and deeply as you exercise; never hold your breath.

**Cooling Down**—Finish with 5 to 10 minutes of stretching. Stretching increases the flexibility of your muscles and helps to prevent post-exercise problems.

## EXERCISE FREQUENCY

To maintain or improve your condition, complete three workouts each week, with at least one day of rest between workouts. After a few months of regular exercise, you may complete up to five workouts each week, if desired. Remember, the key to success is to make exercise a regular and enjoyable part of your everyday life.

## SUGGESTED STRETCHES

The correct form for several basic stretches is shown at the right. Move slowly as you stretch—never bounce.

### 1. Toe Touch Stretch

Stand with your knees bent slightly and slowly bend forward from your hips. Allow your back and shoulders to relax as you reach down toward your toes as far as possible. Hold for 15 counts, then relax. Repeat 3 times. Stretches: Hamstrings, back of knees and back.

### 2. Hamstring Stretch

Sit with one leg extended. Bring the sole of the opposite foot toward you and rest it against the inner thigh of your extended leg. Reach toward your toes as far as possible. Hold for 15 counts, then relax. Repeat 3 times for each leg. Stretches: Hamstrings, lower back and groin.

### 3. Calf/Achilles Stretch

With one leg in front of the other, reach forward and place your hands against a wall. Keep your back leg straight and your back foot flat on the floor. Bend your front leg, lean forward and move your hips toward the wall. Hold for 15 counts, then relax. Repeat 3 times for each leg. To cause further stretching of the achilles tendons, bend your back leg as well. Stretches: Calves, achilles tendons and ankles.

### 4. Quadriceps Stretch

With one hand against a wall for balance, reach back and grasp one foot with your other hand. Bring your heel as close to your buttocks as possible. Hold for 15 counts, then relax. Repeat 3 times for each leg. Stretches: Quadriceps and hip muscles.

### 5. Inner Thigh Stretch

Sit with the soles of your feet together and your knees outward. Pull your feet toward your groin area as far as possible. Hold for 15 counts, then relax. Repeat 3 times. Stretches: Quadriceps and hip muscles.

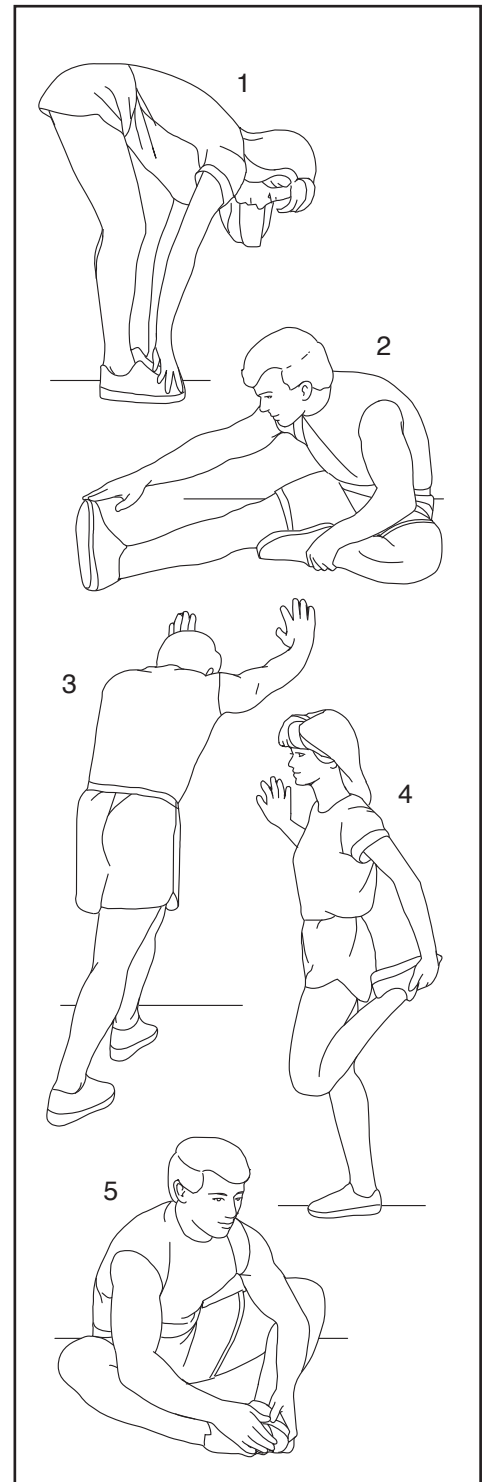

# PART LIST

Model No. PFTL80916.0 R0816A

Key No.	Qty.	Description	Key No.	Qty.	Description
1	10	#8 x 1/2" Screw	53	2	1/4" x 1 1/4" Screw
2	4	1/4" x 1/2" Screw	54	1	Drive Motor
3	2	Base Pad	55	1	Motor Belt
4	45	#8 x 3/4" Screw	56	1	Frame
5	1	Pulse Crossbar	57	1	Left Rear Foot
6	2	1/4" x 4 1/2" Screw	58	1	Console Ground Wire
7	4	3/8" x 2 3/8" Screw	59	4	Rubber Cushion
8	1	Right Handrail Cover	60	1	Right Foot Rail
9	4	#10 x 3/4" Screw	61	1	Idler Roller
10	8	#8 x 1/2" Machine Screw	62	2	3/8" x 1 3/4" Screw
11	4	5/16" Star Washer	63	4	3/8" Plastic Bushing
12	4	#8 x 1" Tek Screw	64	1	Console Base
13	8	3/8" Star Washer	65	1	Motor Hood
14	8	#8 x 3/4" Truss Head Screw	66	4	Cushion Bottom
15	3	1/4" x 2 1/2" Screw	67	2	Incline Frame Spacer
16	1	3/8" x 1 1/2" Bolt	68	5	Hood Clip
17	2	3/8" x 1 1/2" Wheel Bolt	69	1	Incline Motor
18	1	#8 x 1/2" Ground Screw	70	1	Incline Frame
19	4	#8 x 7/16" Screw	71	2	Frame Spacer
20	2	5/16" Motor Screw	72	1	Controller
21	2	3/8" Pin	73	1	Controller Bracket
22	2	3/8" x 1" Bolt	74	2	Base Pad Spacer
23	4	5/16" x 1 3/4" Shoulder Bolt	75	1	Power Switch
24	2	#8 Star Washer	76	1	Power Cord
25	1	Console Frame	77	1	Grommet
26	10	1/4" Star Washer	78	1	Belly Pan
27	1	Right Tray	79	1	Left Handrail Insert
28	4	5/16" x 2 1/4" Screw	80	1	Console
29	1	3/8" x 1 3/4" Hex Head Bolt	81	1	Upright Wire
30	4	5/16" Flat Washer	82	1	Left Base Cover
31	1	Right Handrail Insert	83	1	Right Base Cover
32	2	Incline Motor Spacer	84	2	Handrail
33	6	3/8" Jam Nut	85	1	Base
34	4	5/16" Nut	86	2	Cable Tie
35	4	Small Cushion	87	1	Left Handrail Cover
36	1	Left Tray	88	1	Key/Clip
37	6	#8 x 5/8" Screw	89	1	Left Upright
38	2	Wheel	90	1	Right Upright
39	4	Isolator	91	2	Caution Decal
40	2	Rear Foot	92	2	Console Clamp
41	1	Latch Plate	93	8	M5 Flat Washer
42	1	Left Foot Rail	94	1	1/4" Nut
43	1	Warning Decal	95	1	Controller Clamp
44	1	Walking Platform	96	1	Right Inner Base Cover
45	1	Walking Belt	97	1	Left Inner Base Cover
46	2	Belt Guide	98	1	Storage Latch
47	1	Right Rear Foot	99	4	#8 x 1/2" Machine Screw
48	4	Cable Tie	100	1	Tablet Holder
49	1	Drive Roller/Pulley	101	1	Power Cord Grommet
50	6	3/16" Washer	102	2	9/32" Plastic Bushing
51	2	3/8" x 1 1/4" Screw	*	-	User's Manual
52	2	3/8" Washer			

Note: Specifications are subject to change without notice. For information about ordering replacement parts, see the back cover of this manual. \*These parts are not illustrated.



# EXPLODED DRAWING B

Model No. PFTL80916.0 R0816A

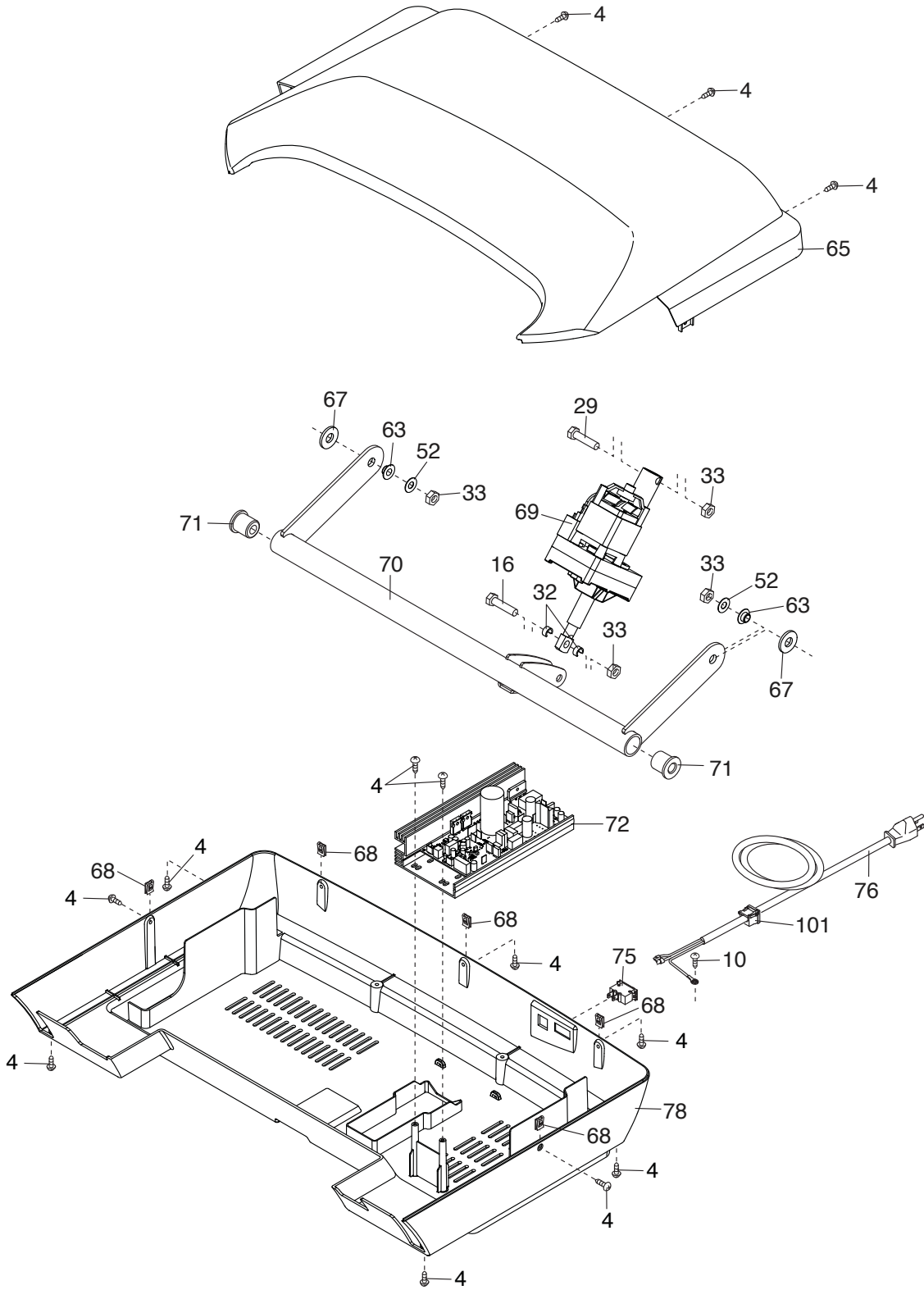

# EXPLODED DRAWING C

Model No. PFTL80916.0 R0816A

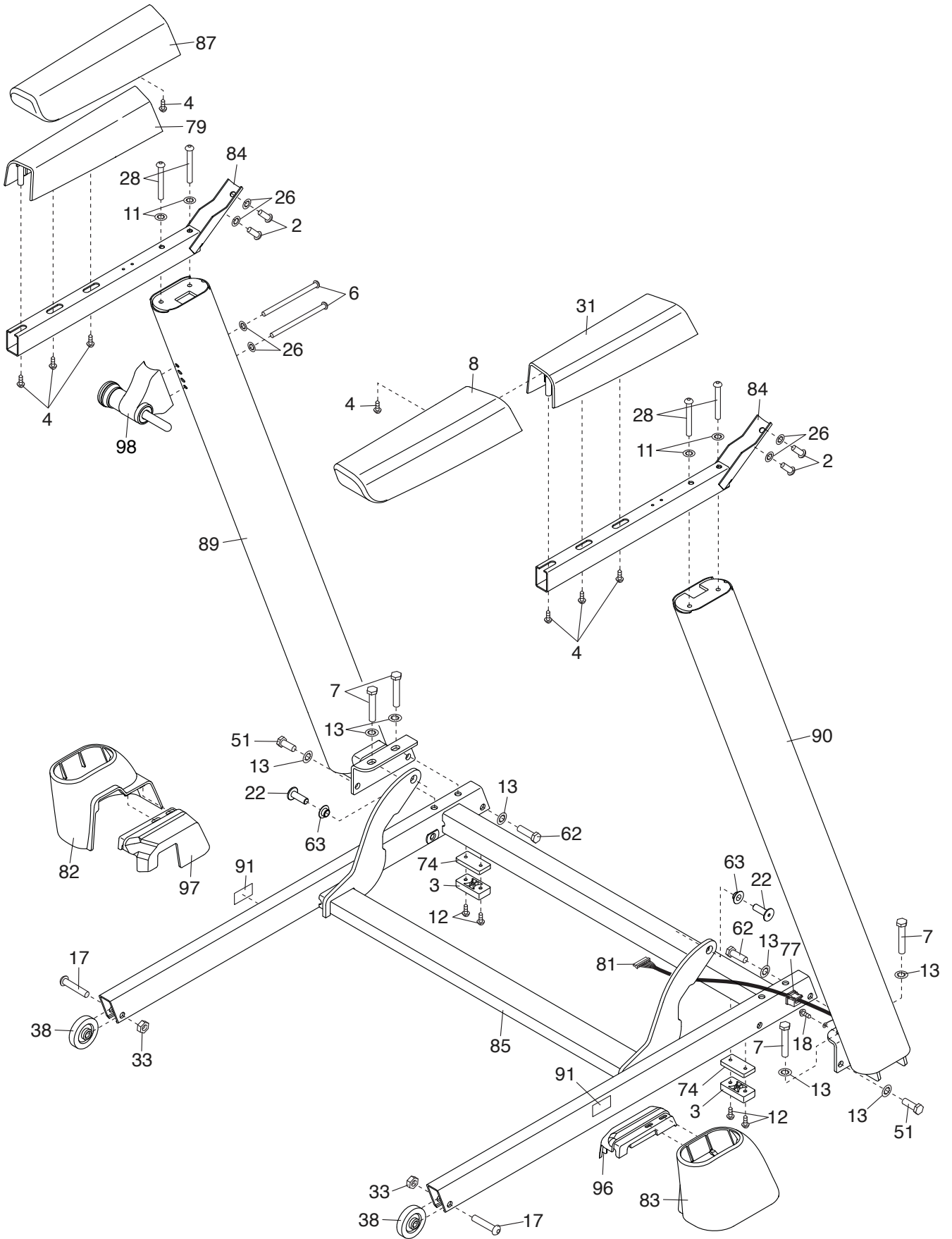

# EXPLODED DRAWING D

Model No. PFTL80916.0 R0816A

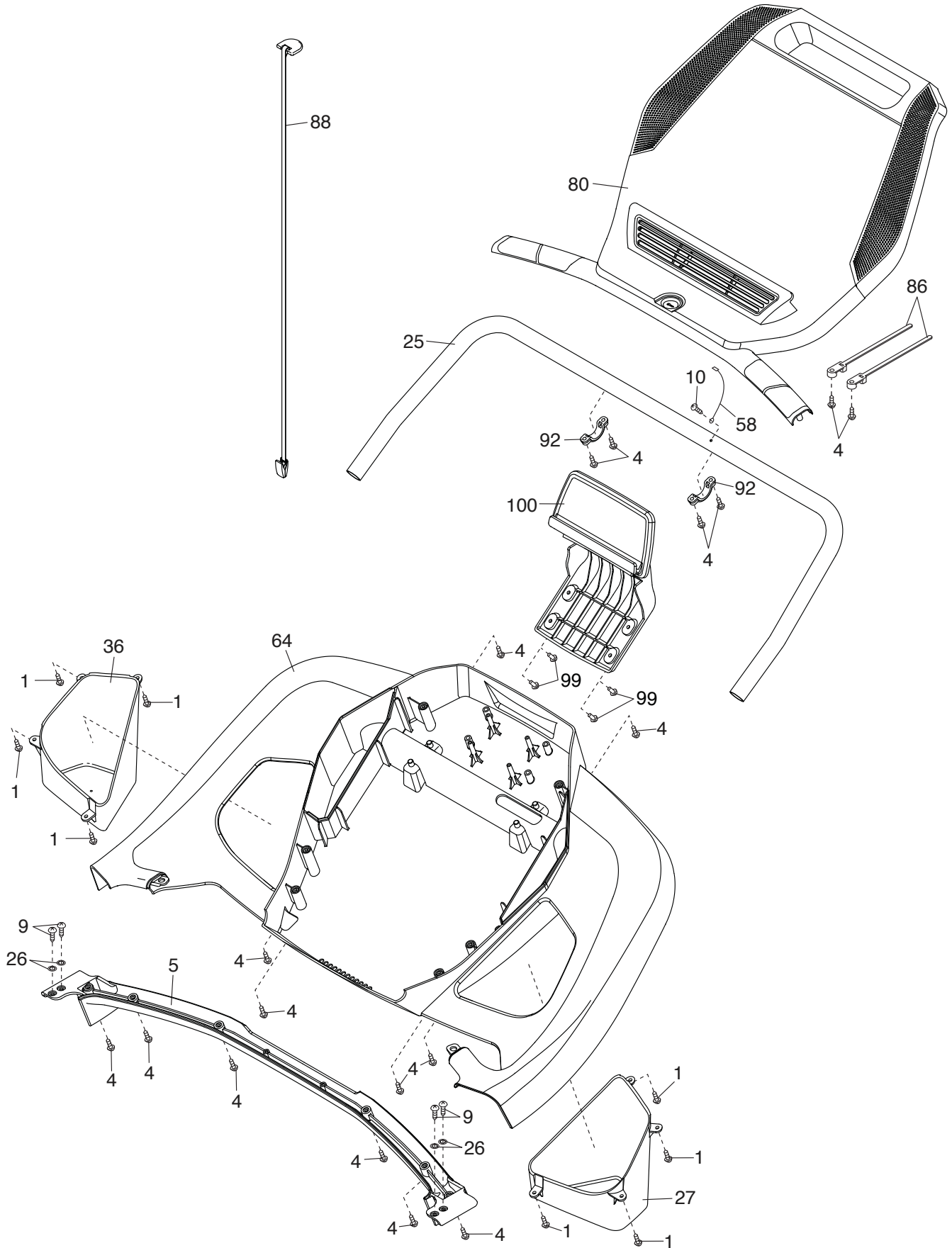

---

# ORDERING REPLACEMENT PARTS

To order replacement parts, please see the front cover of this manual. To help us assist you, be prepared to provide the following information when contacting us:

- the model number and serial number of the product (see the front cover of this manual)
- the name of the product (see the front cover of this manual)
- the key number and description of the replacement part(s) (see the PART LIST and the EXPLODED DRAWING near the end of this manual)

## LIMITED WARRANTY

**IMPORTANT: To protect your fitness equipment with an extended service plan, see page 5.**

ICON Health & Fitness, Inc. (ICON) warrants this product to be free from defects in workmanship and material, under normal use and service conditions. The frame and drive motor are warranted for a lifetime. Parts are warranted for two (2) years from the date of purchase. Labor is warranted for one (1) year from the date of purchase.

This warranty extends only to the original purchaser (customer). ICON's obligation under this warranty is limited to repairing or replacing, at ICON's option, the product through one of its authorized service centers. All repairs for which warranty claims are made must be preauthorized by ICON. If the product is shipped to a service center, freight charges to and from the service center will be the customer's responsibility. If replacement parts are shipped while the product is under warranty, the customer will be responsible for a minimal handling charge. For in-home service, the customer will be responsible for a minimal trip charge. This warranty does not extend to freight damage to the product. This warranty will automatically be voided if the product is used as a store display model, if the product is purchased or transported outside the USA, if all instructions in this manual are not followed, if the product is abused or improperly or abnormally used, or if the product is used for commercial or rental purposes. No other warranty beyond that specifically set forth above is authorized by ICON.

ICON is not responsible or liable for indirect, special, or consequential damages arising out of or in connection with the use or performance of the product; damages with respect to any economic loss, loss of property, loss of revenues or profits, loss of enjoyment or use, or costs of removal or installation; or other consequential damages of any kind. Some states do not allow the exclusion or limitation of incidental or consequential damages. Accordingly, the above limitation may not apply to the customer.

The warranty extended hereunder is in lieu of any and all other warranties, and any implied warranties of merchantability or fitness for a particular purpose are limited in their scope and duration to the terms set forth herein. Some states do not allow limitations on how long an implied warranty lasts. Accordingly, the above limitation may not apply to the customer.

This warranty provides specific legal rights; the customer may have other rights that vary from state to state.

**ICON Health & Fitness, Inc., 1500 S. 1000 W., Logan, UT 84321-9813**