

78-3984-250  
4/17



**Lionel**  
**0-8-0 LionChief®**  
**Ready-To-Run Set**  
**Owner's Manual**



**CAUTION—ELECTRIC TOY**

NOT RECOMMENDED FOR CHILDREN UNDER FOURTEEN YEARS OF AGE. AS WITH ALL ELECTRIC PRODUCTS, PRECAUTIONS SHOULD BE OBSERVED DURING HANDLING AND USE TO PREVENT ELECTRIC SHOCK.

**TRANSFORMER RATINGS—INPUT: 100-240 VAC, 50/60 Hz.**  
**OUTPUT: 18 VDC; 54 VA.**

# Thank You!

**W**elcome to the world of Lionel trains! You're off to a great start with this ready-to-run LionChief train set. This set features everything you need to get started—a wall-pack power supply, a huge, easy-to-assemble FasTrack oval, a string of detailed cars, a powerful Lionel locomotive that is equipped with RailSounds RC sound system, and a LionChief remote that controls all the action.

Have fun growing with this complete train set! Start with the set components, then follow your imagination into your own miniature world. Expand your railroad empire with additional FasTrack track sections, enhance your layout with accessories, lengthen your consist with extra cars, or operate a new LionChief locomotive at the head end of your train!

Use this Owner's Manual to learn how to set up, operate, and maintain your train set for years of reliable operation.

## FCC Statement

---

This device complies with Part 15 of the FCC Rules and with Industry Canada license-exempt RSS standard(s). Operation is subject to the following two conditions: (1) This device may not cause harmful interference, and (2) This device must accept any interference received, including interference that may cause undesired operation.

Contains

FCC ID: 2AH7AKW2541A

IC: 21416-KW2541A



### LionChief<sup>®</sup> Remote control

The LionChief remote control is used to operate the locomotive. Easy to use, and with many enhanced features including a wider range of realistic sounds, such as chuff sounds and three buttons on the control to activate user-controllable announcements and engine sounds. Long-distance control and multi-engine operation on one layout are in your grasp with the LionChief remote control system.



### LionChief<sup>®</sup> Bluetooth<sup>®</sup>

Incorporating Bluetooth technology into Lionel model trains opens a new world, integrating the tradition of model railroading with the latest smart-device technology. With Lionel's new LionChief app, you can control full operation and sounds directly from your Bluetooth-enabled smart phone or tablet and operate multiple locomotives from the same device. LionChief is available to smartphone users and is compatible with all new 2017 LionChief, LionChief Plus, S-Gauge, and HO Trains.

**The Bluetooth<sup>®</sup> word mark and logos are registered trademarks owned by the Bluetooth SIG, Inc. and any use of such marks by Lionel is under license. Other trademarks and trade names are those of their respective owners.**

*The following Lionel marks are used throughout this Owner's Manual and are protected under law. All rights reserved.*

*Lionel<sup>®</sup>, LionChief<sup>®</sup>, LionChief Plus<sup>®</sup>, FasTrack<sup>®</sup>, RailSounds<sup>®</sup>, ElectroCoupler<sup>™</sup>, Plug-Expand-Play<sup>®</sup>, LEGACY<sup>®</sup>, LEGACY<sup>®</sup> Control System, Lockon<sup>®</sup>*

# **Table of contents**

## **Safety information**

Operating your wall-pack power supply safely 4

## **LionChief system basics**

Model railroading with the LionChief system 5

Installing AAA batteries into the Remote Control 6

Operating your train with LionChief remote 7

## **LionChief locomotive overview**

Locomotive Overview 8

Building your Lionel layout 9

Joining the FasTrack track sections 9

Connecting your wall-pack power supply 10

## **Operating your train set**

Adding smoke fluid to your locomotive's smoke generator 11

Running your train set 12

Triggering announcements with your LionChief remote control 13

Coupling 13

The Lionel Plug-Expand-Play lock-on 14

Silencing the steam chuffing sounds 15

## **Using the LionChiefApp**

Connecting to your LionChief, LionChief Plus, or FlyerChief locomotive 16

What if my Bluetooth enabled engine didn't automatically connect? 17

Running Your Locomotive 17

Settings 18

Volume Control 18

Switching Connection Between Multiple Bluetooth<sup>®</sup> Locomotives 19

Troubleshooting 19

## **Maintaining and servicing your set**

Lubricating your locomotive 20

Replacing your locomotive's traction tire 21

Replacing your locomotive's headlamp 21

Wall Pack Power Supply 22

FCC Statement 23

## **LionChief Troubleshooting**

Troubleshooting 24-26

Notes 27

Lionel Limited Warranty Policy & Service 28

# ***Safety information***

## **Operating your wall-pack power supply safely**

---

**Y**our Lionel wall-pack power supply is listed by Underwriter's Laboratory Inc. and has been carefully designed to ensure peak performance. When using electrical products, basic safety precautions should be maintained.

Be sure to observe the following guidelines:

- Read the manual thoroughly before using this device.
- This device is not recommended for children under fourteen years of age.
- Parents should periodically inspect this product for potential hazards and, if necessary, have them repaired by a Factory Trained Authorized Lionel Service Station. In the event that such a condition exists, the transformer should not be used until it has been properly repaired.
- The wall-pack power supply is intended to be used indoors. Do not use this device if water is present. Serious or fatal injuries may result.
- Use the wall-pack power supply only for its intended purpose.
- The wall-pack power supply was designed to operate on 100-240 volt AC, 60-Hertz power. 18 VDC output. Do not connect this product to any other power supply.
- Do not operate the wall-pack power supply with a damaged cord, plug, or case.
- To avoid the risk of electrical shock, do not disassemble the unit. There are no user serviceable parts inside. If damaged, take this product to a Factory Trained Authorized Lionel Service Station. Visit [www.lionel.com](http://www.lionel.com) for a list of authorized Service Centers.
- Do not operate the wall-pack power supply on your layout unattended. Obstructed accessories or stalled trains may overheat, resulting in damage to your layout.
- Always unplug the wall-pack power supply from the power source when not in use.
- Never insert objects into the ventilation slots on this product. Damage to sensitive electronic components can result.

### ***ATTENTION!***

**Y**our new Lionel LionChief 0-8-0 Locomotive and Tender has unique wiring that makes it different from other LionChief products. We strongly discourage mixing the 0-8-0 Locomotive or Tender with ANY other LionChief Locomotive or Tender.

Running the 0-8-0 engine with a different style tender, or the 0-8-0 tender with a different style engine WILL result in damage to the unit's electronics and void the product warranty.

All O Gauge rolling stock is interchangeable between locomotives types.

# ***LionChief system basics***

## **Model railroading with the LionChief system**

---

**Y**our ready-to-run LionChief train set comes with a DC wall-pack power supply, a LionChief remote control, a LionChief-equipped locomotive, rolling stock, and a FasTrack oval, complete with a wall-pack terminal section for simple and easy set up.

Your locomotive runs on fixed voltage, which is optimal for the sound system, smoke system, and lamps. The locomotive listens to commands from its LionChief remote at a specific frequency to increase or decrease speed, change directions, or trigger sounds. That's why the locomotive and remote must be operated as a matched pair.

The DC wall-pack power supply is capable of running the locomotive and cars that come with this set, plus a few add-on cars and accessories, depending on the power they require. Keep in mind that your locomotive can run on AC power, too, so you may choose to upgrade to most Lionel or Lionel-compatible AC transformers (available separately at your authorized Lionel retailer) when you expand your layout.

### **Important!**

Run only your layout with only the DC wall-pack power supply OR an AC transformer. Do not run both! Also, keep in mind that most other Lionel locomotives require AC power specifically; check the instructions included with the other locomotives.

If you do choose to run your LionChief locomotive with a transformer, set the train voltage to full (18 volts) and use the remote to run the train and trigger the sounds. The locomotive is not designed to respond to the transformer's throttle, direction button, horn button, or bell button; the locomotive only responds to commands from its LionChief remote.

Keep in mind that the remote that comes with the train set is paired with the locomotive. This locomotive and remote share a frequency, and your LionChief remote will not communicate with other locomotives. However, locomotives of the same type, for example a 2-8-4 berkshire, may share a frequency. Where the frequency is shared, any locomotive of the same type on the track would respond together, at the same time, to commands from a remote. To avoid this scenario, you may choose not to run multiples of the same locomotive type at the same time.

Otherwise, you may run more than one LionChief-equipped locomotive on the track at the same time. You may also choose to run your LionChief locomotive on a LEGACY Control System-equipped layout; however, you must use your LionChief remote control to control the LionChief locomotive (LionChief locomotives do not receive commands from the LEGACY remote).

# The LionChief remote control overview

## Installing AAA batteries into the Remote Control

---

**F**or safety purposes, you must use a Phillips screwdriver to access the battery compartment. Use a Phillips screwdriver to remove the screw that secures the battery compartment hatch and lift the hatch to access battery compartment (as shown in Figure 1). Insert three AAA batteries orientating the +/- as shown in the bottom of the battery compartment. Replace the battery door and replace the screw.

**Important!** Use only Alkaline AAA batteries. Use only new batteries. Never mix new and used batteries or use different types together.

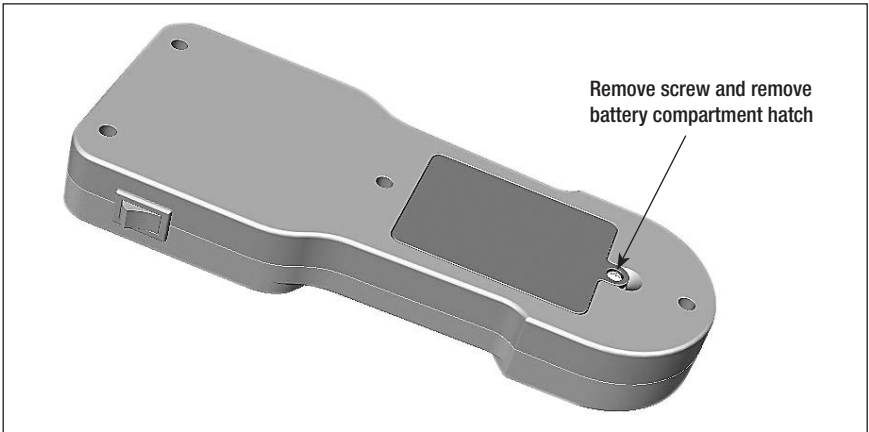

Figure 1. Opening and closing the battery compartment

**Important!** REMOVE ALL BATTERIES WHEN THE TRAIN WILL NOT BE USED FOR AN EXTENDED PERIOD OF TIME. LIONEL'S LIMITED WARRANTY DOES NOT COVER DAMAGE TO YOUR REMOTE CAUSED FROM LEAKING BATTERIES.

**Important!** When you are not operating the train, flip the On/Off switch to the Off position to conserve the batteries.

# ***The LionChief remote control overview***

## **Operating your train with your LionChief remote**

---

### ***THROTTLE***

Control speed and direction with the knob. Turn the knob to the right to move forward, left for reverse and back to center (top) for stop. The LED indicator light will flash to indicate that speed signals are being sent to the locomotive.

### ***SPEED INDICATOR LIGHT***

The red light will remain on during normal operation. The light will begin to flash when the locomotive is in motion, and the flashing will vary with the locomotive's speed.

### ***ON/OFF SWITCH***

Turn remote control on and off. We recommend turning off the remote when not in use to conserve battery life. Remove the batteries for storage.

### ***BELL***

Press the BELL button to begin the bell sounds; press the button again to turn off the bell.

### ***ANNOUNCEMENTS***

Press the center button for a variety of announcements.

### ***WHISTLE***

The WHISTLE button will activate your locomotive's whistle.

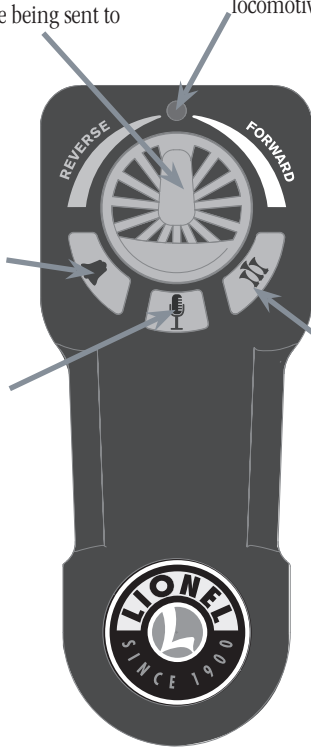

# ***The LionChief locomotive overview***

## **Locomotive Overview**

---

**Y**our LionChief locomotive is designed to operate with commands from its corresponding LionChief remote. You may choose to power it with the wall-pack power supply included with this ready-to-run train set, or you may choose to expand and upgrade to essentially any Lionel or Lionel-compatible AC transformer. Even DC transformers will work to power this particular locomotive!

### **Smoke**

Your locomotive features an operating smoke unit that produces safe, clean, white smoke. Always keep a small amount of smoke fluid in the smoke unit when you are running your locomotive with the smoke unit in the On position. Slide the smoke unit switch to the Off position if you do not want to operate the locomotive with smoke or you choose not to add smoke fluid. For more information, please see page 11. Only Lionel Premium Unscented and Scented Smoke Fluids are approved for use with this product.

### **LionChief RC sound system**

Your locomotive features a wide range of sounds to make operation even more realistic and impressive! The steam chuffing sounds are coordinated with the blasts of smoke from the smokestack, and they increase with the speed of the locomotive. You may choose to turn the chuffing sounds off by sliding the sound switch to the off position. See page 15.

Use the whistle, bell, and announcement buttons on the LionChief remote control to trigger those sounds. See page 7 for more information.

Keep in mind that the speaker is housed in the tender. Ensure that the drawbar is connected properly for good electrical contact.

### **Care and maintenance**

A few simple precautions will help to ensure a long life for the locomotive:

- Lubricate the wheels, axles, and linkage regularly to avoid squeaks and wear. See page 20 for complete details.
- Avoid squeezing and bending the side rods and linkage when handling and packing the locomotive to prevent binding.

# Getting ready to run your trains

## Building your Lionel layout

---

**Y**our set comes with eight O36 curved sections, two 10" straight sections, one wall-pack terminal section of track, and one 10" Plug-Expand-Play power lock-on track section. Figure 2 shows the oval layout that you can build with these track sections. You may choose to add more FasTrack track sections to create an endless number of exciting track arrangements for more fun, action, and variety.

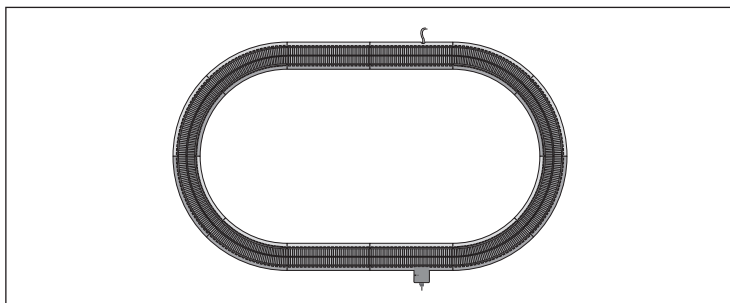

Figure 2. Track layout

## Joining the FasTrack track sections

---

**F**asTrack track sections join together easily. With interlocking roadbed sections and large rail tabs, the track fits together securely so you always have good electrical contact. Take a look at Figure 3 to see how to join the track sections.

1. Line up your two sections of track.
2. Insert the rail tabs into the openings at the ends of the corresponding rails.
3. Press the sections together until the interlocking roadbed snaps into place.

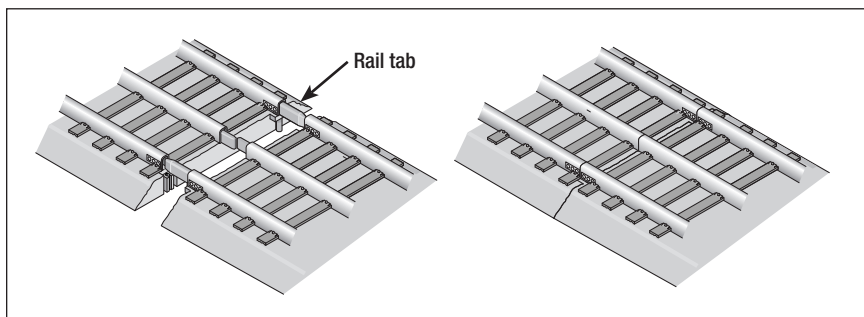

Figure 3. Joining the track sections

# Getting ready to run your trains

## Connecting your wall-pack power supply

---

**Y**our trains are powered by a DC wall-pack power supply. To power the track, simply plug the wall-pack into an outlet and plug the jack into the terminal section as shown in Figure 4.

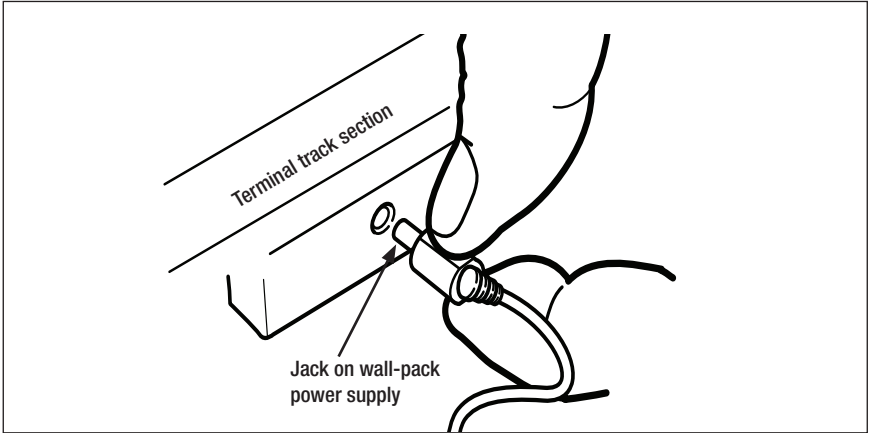

Figure 4. Wall-pack power supply connection

# ***Operating your train set***

## **Adding smoke fluid to your locomotive's smoke generator**

---

**Y**our locomotive is equipped with a smoke generator that produces safe, clean white smoke during operation if the smoke unit switch is in the ON position. Refer to Figure 8 on page 15 for the location of the switch.

The smoke generator requires the periodic addition of Lionel smoke fluid in order to function. A small bottle of smoke fluid is included with this set. Press down and unscrew the cap. Pierce the end of the nozzle with a pin, then add about four drops of fluid directly into the locomotive's stack. Smoke production commences momentarily. It will start faster if you run your locomotive at higher speeds. When smoke production decreases, add more fluid (about four drops). An idle locomotive will not smoke.

**Note!** If you prefer to operate the locomotive without smoke or you do not want to add smoke fluid, slide the smoke unit switch to the OFF position.

**Caution!** When the smoke unit switch is in the ON position, always keep a small amount of smoke fluid in the locomotive's smoke generator; the generator's element can become damaged if operated without smoke fluid. This is particularly true if your locomotive sits in neutral for an extended period of time without smoke fluid in the generator.

# Operating your train set

## Running your train set

---

**1**

***With track power unplugged, place your train set on the track.***

Refer to the following section for information on coupling the cars.

**2**

***Couple the locomotive to the tender that was included with this set***

Fit the tab on the locomotive drawbar into the slot on the tender's drawbar as illustrated in Figure 5. Note that the drawbar connection connects the locomotive and tender electronically. Make the connection securely to ensure good electrical contact.

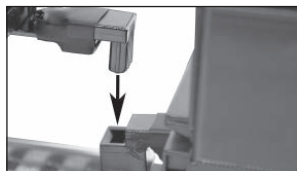

Figure 5. Drawbar connection

**Caution!**

To prevent damage to the electronics, only couple the locomotive to the tender that was included with this set. Do **NOT** mix and match LionChief locomotives and tenders.

**3**

***Plug in your wall-pack power supply, connect it to the track, and switch on the remote.***

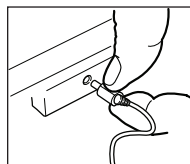

**4**

***Move 'em out!***

Use your remote to run your train. You can adjust the speed in forward or reverse, blow the whistle, sound the bell, or trigger an announcement. Refer to page 13 for complete details.



**5**

***Unplug the wall-pack power supply when you are done running your trains.***

Switch off your remote control to conserve the batteries.

# Operating your train set

## Triggering announcements with your LionChief remote control

---

**Y**our locomotive plays a variety of announcements that are designed to match the way you play with the locomotive. You can trigger an announcement that corresponds to each part of the journey.

### When the locomotive is...

Sitting less than 30 seconds	Stopped announcement 1 will play
Sitting less than 30 seconds	Stopped announcement 2 will play
Sitting more than 30 seconds	Stopped announcement 3 will play
Moving less than 30 seconds	Moving announcement 1 will play
Moving less than 30 seconds	Moving announcement 2 will play
Moving more than 30 seconds	Moving announcement 3 will play

## Coupling

---

**W**hen coupling your cars, at least one of the mating couplers must be open as shown at the left in Figure 6. Press down on the lock release to open the coupler, then push the cars toward each other until they lock together.

**Note!** Keep in mind that it's easier to couple cars on a straight section of track.

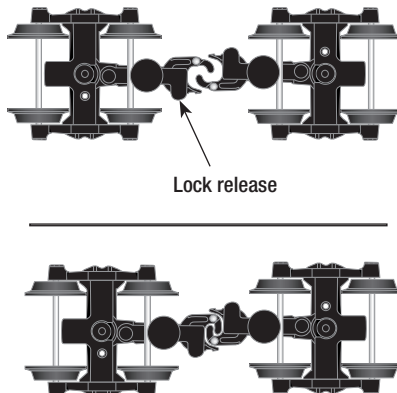

Figure 6. Coupler operation

# Operating your train set

## The Lionel Plug-Expand-Play lock-on

Included with your set is a complementary single port Plug-Expand-Play lock-on compatible with any Plug-Expand-Play accessory; however, this lock-on will not work with animated accessories. (To obtain a lock-on designed to trigger an animated accessory based on the presence of a train you need the 6-81317 Accessory Activator Lock On.) Each accessory has a cable attached to its base that plug into the lock-on's 3-pin female connectors.

This piece of FasTrack only uses 2 of the 3 terminals in the attached lock-on; red and black, connected under the track. The red wire connects to the center rail to supply power to the accessory. The black wire connects to the outside rail to supply ground power to the accessory. The white wire is not used with this item. See figure 7.

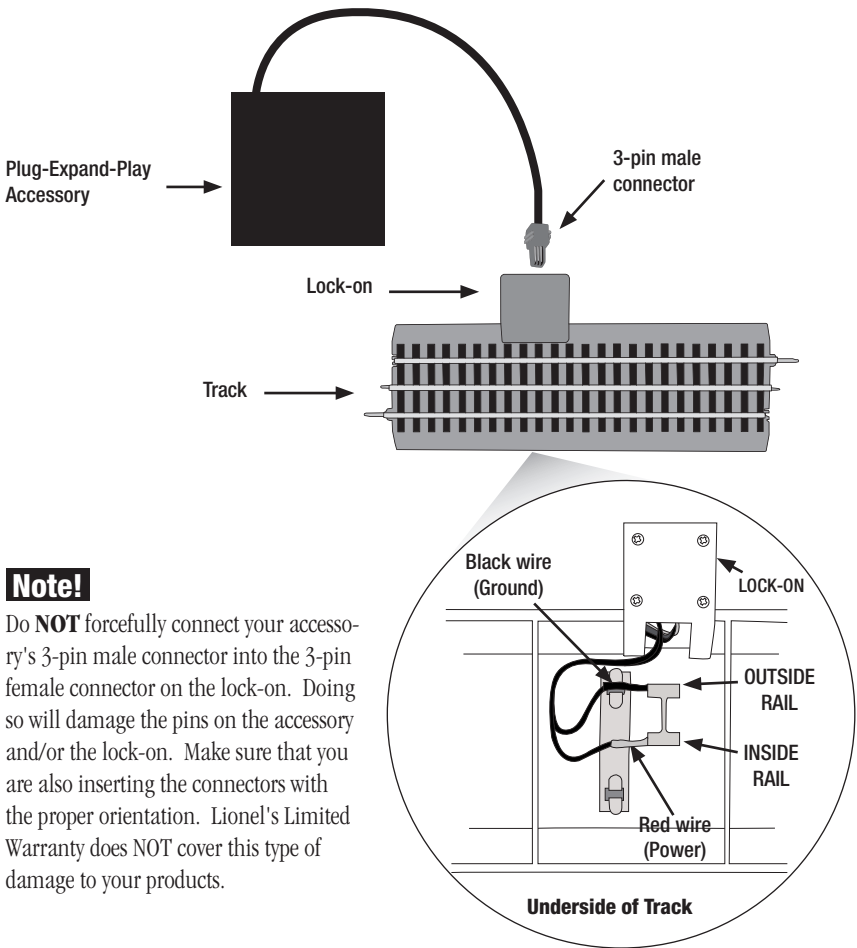

### Note!

Do **NOT** forcefully connect your accessory's 3-pin male connector into the 3-pin female connector on the lock-on. Doing so will damage the pins on the accessory and/or the lock-on. Make sure that you are also inserting the connectors with the proper orientation. Lionel's Limited Warranty does **NOT** cover this type of damage to your products.

Figure 7. Connecting a Plug-Expand-Play accessory

# Operating your train set

## Silencing the steam chuffing sounds

---

To silence the background steam sounds, slide the CHUFF switch to the OFF position under the frame. See Figure 8. Turn off track power for about two seconds, and then the background sound will be silenced when the track power is restored. The whistle, announcement, and bell sounds can still be triggered at any time using the remote. To restore the background sounds, simply slide the CHUFF switch to the ON position and then turn off track power for two or more seconds.

**Note!** Always turn off track power for about two seconds after you slide the switch. The background sounds will be reset according to the new switch position when the track power is switched on again.

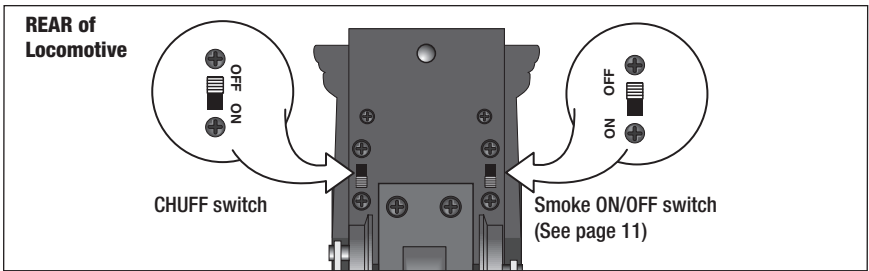

Figure 8. Switch locations

# Using the LionChief App

## Connecting to your LionChief, LionChief Plus, or FlyerChief locomotive

Once you have downloaded the free LionChief app and your locomotive is powered up on the track, tap the LionChief icon on your smart device.

This screen will be present and within a few seconds it will automatically connect with your locomotive. Once it has connected, your Bluetooth enabled locomotive will show up in the locomotive box. You are now ready to operate your locomotive.

**Note!** Your locomotive will make a chirping sound until the connection process is complete.



Figure 9a. App screen when trying to connect to a locomotive



Figure 9b. App screen when a locomotive is connected

# Using the LionChief App

## What if my Bluetooth enabled engine didn't automatically connect?

**T**ap on the locomotive box. Your locomotive will show up at top, click the link button and you're all set to begin running your locomotive.

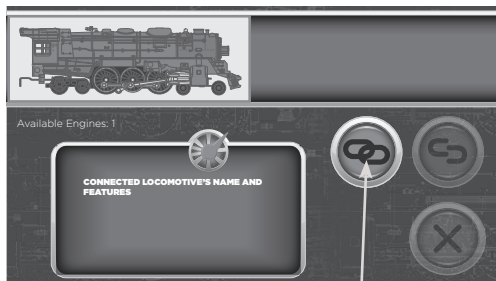

Figure 10. App screen to select a locomotive

## Running your locomotive

**T**his is your main control panel.

**Note!** Grayed out icons means this feature is not available on your locomotive.

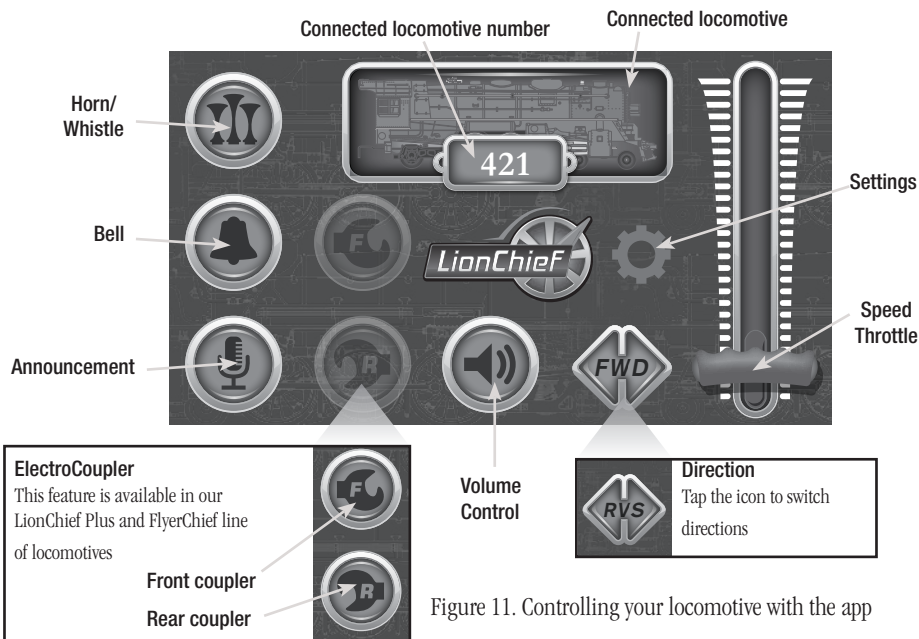

Figure 11. Controlling your locomotive with the app

# Using the LionChief App

## Settings

On the setting screen, you will be able to establish key elements of how your locomotive will run including smoke, momentum and speed limit. These settings will reset once you are done running the locomotive and close out of your LionChief app.

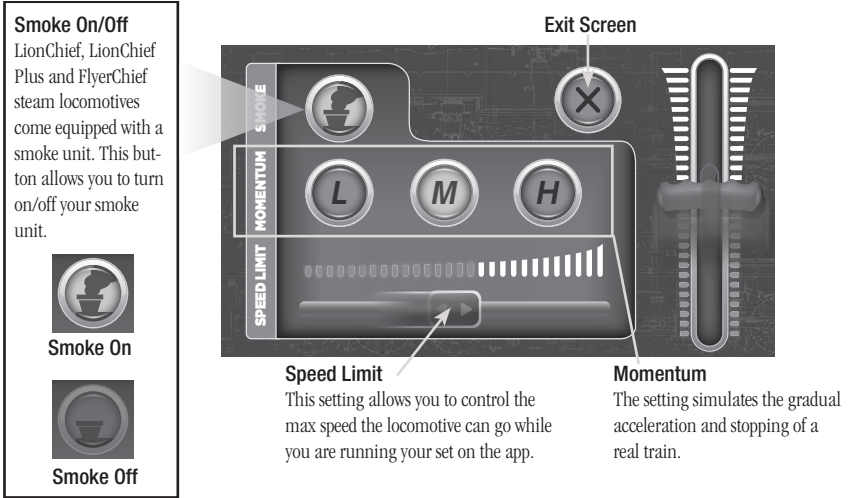

Figure 12. Adjusting locomotive speed and smoke settings

## Volume Control

Our LionChief, LionChief Plus and FlyerChief locomotives come equipped with a very impressive RailSounds sound system. This section of the app will allow you to establish the volume for individual sound elements or the overall sound level.

**Note!** Once these are established here, the characteristics will continue both on the app or with your remote until you choose to change them again.

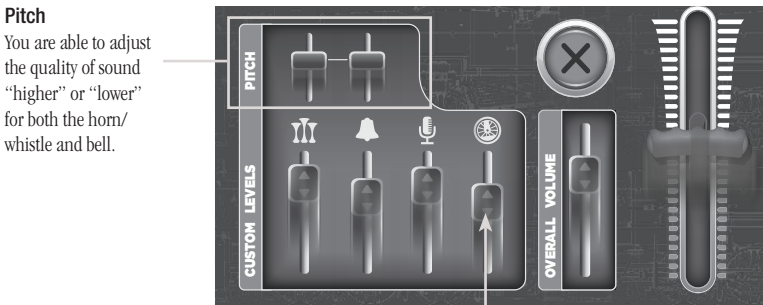

Figure 13. Adjusting locomotive individual and overall volume levels

# Using the LionChief App

## Switching Connection Between Multiple Bluetooth® Locomotives

Your LionChief app will display all “available” locomotives in the engine selection carousel. If you have three or more available engines, touch and scroll right to view them. Switching between available locomotives is easy, press the un-link icon to release the currently connected engine. Alternately, you can highlight the engine you would like to run and press the Link icon to connect. In both cases, if the previously selected locomotive was in motion, it will stop when disconnected.

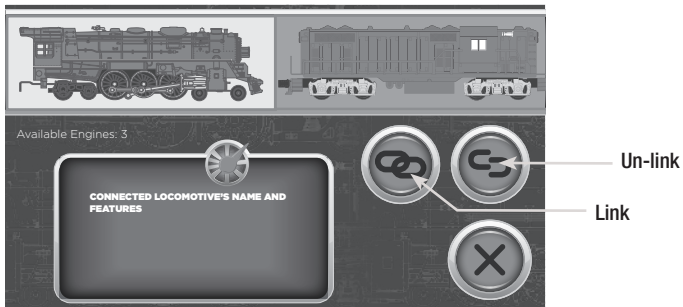

Figure 14. Switching between three locomotives

## Troubleshooting

- If the locomotive does not appear in the App's “engine selection carousel,” try turning the track power off, wait 5 seconds and turn it back on.
- If the locomotive powers up and starts playing its background sound instead of chirping, there is another remote connecting to the locomotive. Since the locomotive can only be controlled by one remote at a time, locate and turn off the other remote that is connecting to the engine.
- If a universal remote is present and powered on, make sure one of its 3 channels is not connecting to your locomotive before the App is able to connect.
- Verify that the locomotive works as expected with its provided remote or with the Lionel Universal remote.

# Maintaining and servicing your set

## Lubricating your locomotive

**H**elp your steam locomotive lead a long and productive life on your railroad by maintaining it properly.

We recommend that you purchase a Lionel Lubrication and Maintenance Kit (6-62927), available from your Lionel dealer. Two basic rules to keep in mind: never over-lubricate (a small amount will do) and avoid getting grease or oil on the locomotive's wheels, contact rollers, or your track.

You'll know your locomotive requires lubrication when visual inspection reveals dryness on the parts indicated in Figure 15 and also on the tender's axles. Remove accumulated dirt and dust before lubricating, and always lubricate any locomotive emerging from prolonged storage.

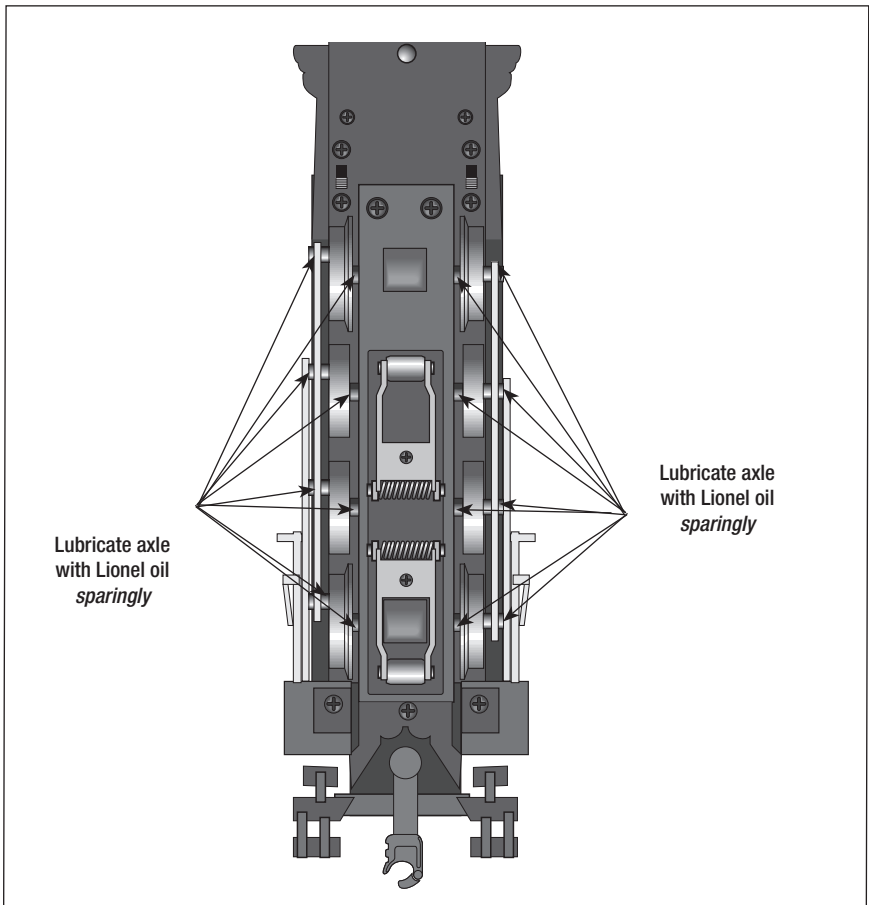

Figure 15. Lubricating points

# Maintaining and servicing your set

## Replacing your locomotive's traction tire

---

One of the locomotive's drive wheels is fitted with a rubber traction tire to enhance tractive effort, allowing your locomotive to pull many cars at once.

To replace the traction tire, simply unscrew the drive rod nut from the wheel using a 3/16" nut driver. Refer to Figure 16. Remove the old traction tire from under the drive rod and slip on the replacement. Replace the spacer, retighten the drive rod nut, and you're ready to pull that long freight back to the yard.

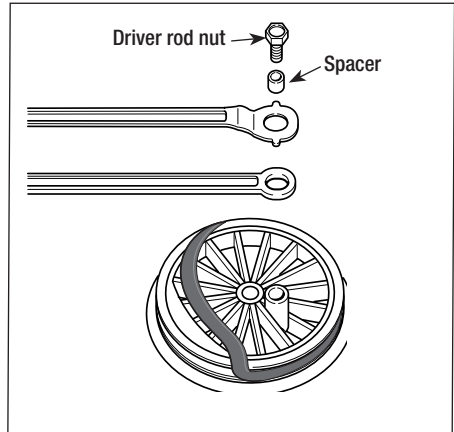

Figure 16. Traction tire replacement

## Replacing your locomotive's headlamp

---

Your locomotive is equipped with an LED style headlight for longer life. Please contact your nearest Lionel Service Center or Lionel Service if this need replacing.

## Wall-pack power supply

# CAUTION-ELECTRIC TOY

Not recommended for children under 14 years of age. As with all electric products, precautions should be observed during handling and use to prevent electric shock.

MODEL: SW1803000-Q04

INPUT: 100-240VAC, 60Hz

OUTPUT: 18VDC, 54VA

Keep these instructions for further reference. They contain important information.

### OPERATION:

1. Plug the transformer into standard wall outlet
2. Connect the transformer to the appliance
3. Turn off the appliance and unplug the transformer from the wall outlet when not in use.

### SPECIAL NOTE TO ADULTS:

- This transformer is age-graded for ages 14 and over, the transformer should not be operated in the presence of children under 14 without adult supervision. Adult supervision is recommended.
- It is recommended that the toy transformer be periodically examined for conditions that may result in the risk of fire, electric shock, or injury to persons (such as damage to the output cord, blades, housing or other parts) and that, in an event of such conditions, the transformer should not be used until properly repaired.



# ***FCC Statement***

## **FCC Statement**

---

Warning: Changes or modifications to this unit not expressly approved by the party responsible for compliance could void the user authority to operate the equipment.

.....

Notes: This equipment has been tested and found to comply with the limits for a Class B digital device, pursuant to Part 15 of the FCC Rules. These limits are designed to provide reasonable protection against harmful interference in a residential installation. This equipment generates, uses and can radiate radio frequency energy and, if not installed and used in accordance with the instructions, may cause harmful interference to radio communications.

However, there is no guarantee that interference will not occur in a particular installation. If this equipment does cause harmful interference to radio or television reception, which can be determined by turning the equipment off and on, the user is encouraged to try to correct the interference by one or more of the following measures:

- Reorient or relocate the receiving antenna.
- Increase the separation between the equipment and receiver.
- Connect the equipment into an outlet on a circuit different from that to which the receiver is connected.
- Consult the dealer or an experienced radio/TV technician for help.

**This device complies with part 15 of the FCC Rules. Operation is subject to the following two conditions: (1) this device may not cause interference, and (2) this device must accept any interference, including interference that may cause undesired operation.**

**This device complies with Industry Canada license-exempt RSS standard(s). Operation is subject to the following two conditions: (1) this device may not cause interference, and (2) this device must accept any interference, including interference that may cause undesired operation of the device.**

**Parents! The adaptor should be periodically examined for the conditions that may result in the risk of fire, electric shock, or injury to persons and that, in an event such conditions , the adaptor should not be used until properly repaired.**

# ***LionChief Troubleshooting***

**Problem: The power indicator LED on the terminal track is not illuminated.**

**Resolution:**

If any of the wheels of the train are not properly positioned on the rails, a short circuit will occur and the circuit breaker inside the transformer will prevent power from being applied to the track until that short circuit is removed.

Remove the locomotive and all cars from the track. With no trains on the track check to see if the LED is illuminated. If it is not illuminated, disconnect the track one piece at a time until the LED comes on. If the problem is a section of track, the LED will illuminate when that section of track is removed from the layout.

Now disconnect the barrel jack from the terminal section and place only one car on the track once the car is on the track reconnect the barrel jack into the terminal section. The LED should be illuminated, if it does illuminate, disconnect it again and place another car on the track. Repeat this process until the entire train, including the locomotive, is on the track.

**Problem: One or more of the illuminated cars will not light.**

**Resolution:**

The lamps in your trains are designed for easy replacement in the event they burn out over time. It is possible that a lamp can become disconnected in transit; as such we suggest you first check the lamp in its socket to ensure it is seated properly.

The lamps inside the cars and locomotive get their power from the rails. There are two wires connected to the trucks on each illuminated car. One wire connects to the center rail collector (roller), and one wire attaches to a contact for the axles that ride on the outside rails. Because the trucks are able to pivot back and forth, it is possible that one or both of these wires may become disconnected from these contacts and short out when they touch one another. The wires can be reconnected by having an adult solder them to their contacts. You may want to take the item to a local Factory Trained Authorized Lionel Service Station for this repair.

**Problem: The train cars will not stay coupled to one another.**

**Resolution:**

The couplers on each car come equipped with an uncoupling plunger, which allows you to uncouple the cars using an Uncoupling Section. These plungers have a pin which holds the knuckle closed, sometimes the plunger will need to be bent upwards slightly to ensure the pin holds the knuckle shut. Use a pair of needle-nosed pliers to bend the plunger upwards slightly. This operation is shown in the illustration below.

## ***LionChief Troubleshooting (continued)***

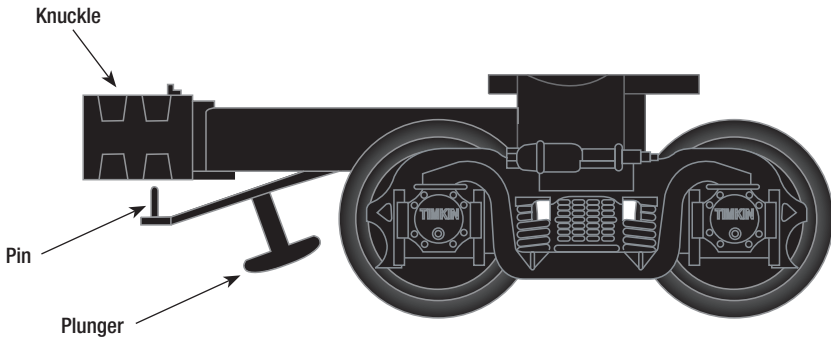

**Problem: I do not hear any sounds from the locomotive.**

**Resolution:**

The drawbar, which connects your locomotive to its tender, serves two purposes. It connects the locomotive and tender together and it serves as a four-conductor tether responsible for transferring the speaker leads from the electronics inside the locomotive to the speaker inside the tender. Ensure the male side of the drawbar (locomotive side) is fully and properly inserted into the female side of the drawbar (tender side) and that the tops of each side of the drawbar are even with one another.

Make sure the sound on/off switch is positioned to the “on” setting and power is being applied to the track. If the switch is set to the “off” position, only the horn/whistle and bell will be heard when the commands are sent to the locomotive from the remote.

**Problem: The locomotive does not smoke.**

**Resolution:**

Ensure the smoke on/off switch is in the “on” position. The locomotive must be moving for smoke to be seen ejecting from the stack. The locomotive will not smoke when sitting at idle. Ensure you have added 4-5 drops of Lionel Liquid Smoke Fluid. It should only take 5-10 seconds for smoke to vaporize and begin being ejected from the stack once the train begins to move. If you do not plan to use the smoke feature on this locomotive be sure the smoke on/off switch is placed in the “off” position, so no damage occurs to the smoke generator.

## ***LionChief Troubleshooting (continued)***

**Problem: The LionChief Remote will not control the locomotive.**

**Resolution:**

First, ensure the remote you are using to control the locomotive is the proper one, mated to that locomotive. Reference the road name and road number printed on the remote with the road name and road number of the locomotive you are trying to control. Second, ensure you have installed three new Alkaline AAA batteries into the remote and the on/off switch is set to the “on” position. Also, if you have been running your locomotive with our LionChief app, make sure to un-link the engine. See page 19.

The red LED at the top of the remote should be on steady when the speed dial is in the top dead center position.

The LED will begin to blink when the throttle knob is turned in either direction, slowly to quickly, mimicking the speed you set for the locomotive. The sounds in the locomotive should be on when you attempting to make the train go. If your locomotive will not move, you will need to take both the wireless LionChief remote and the locomotive and tender to a local Factory Trained Authorized Lionel Service Station or contact Lionel Customer Service for further assistance.



## Lionel Limited Warranty Policy & Service

---

This Lionel product, including all mechanical and electrical components, moving parts, motors and structural components, with the exception of **LIGHT BULBS, LED's & TRACTION TIRES** are warranted to the original owner-purchaser for a period of **one year from the original date of purchase** against original defects in materials or workmanship when purchased through a **Lionel Authorized Retailer\***.

This warranty does **NOT** cover the following:

- Normal wear and tear
- Light bulbs or LED's
- Defects appearing in the course of commercial use
- Damage resulting from abuse/misuse of the product

Transfer of this product by the original owner-purchaser to another person voids this warranty in its entirety. Modification of this product in any way; visually, mechanically or electronically, voids the warranty in its entirety.

Any warranted product which is defective in original materials or workmanship and is delivered by the **original owner-purchaser** (this warranty is non-transferable) to Lionel LLC or any Lionel Authorized Service Station **MUST** be accompanied by the original receipt for purchase (or copy) from an **Authorized Lionel Retailer\***, will at the discretion of Lionel LLC, be repaired or replaced, without charge for parts or labor. In the event the defective product cannot be repaired, and a suitable replacement is not available, Lionel will offer to replace the product with a comparable model (**determined by Lionel LLC**), if available. In the event a comparable model is not available the customer will be refunded the original purchase price (requires proof of purchase from the **Authorized Lionel Retailer\*** it was originally purchased). Any products on which warranty service is sought must be sent freight and postage prepaid (Lionel will refuse any package when postage is due). **Transportation and shipping charges are not covered as part of this warranty.**

**NOTE: Products that require service that do not have a receipt from an LIONEL AUTHORIZED RETAILER\* will be required to pay for all parts required to repair the product (labor will not incur a charge) providing the product is not older than 3 years from date of manufacture and is within 1 year from date of purchase. A copy of the original sales receipt is required.**

### In no event shall Lionel LLC be held liable for incidental or consequential damages.

---

Some states do not allow the exclusion or limitation of incidental or consequential damages, so the above exclusion may not apply to you. This warranty gives you specific legal rights and you may have other rights which vary from state to state.

### Instructions for Obtaining Service

---

If service for this Lionel LLC product is required; bring the item, along with your DATED sales receipt and completed warranty information (at the bottom of this page) to the nearest Lionel Authorized Service Station. Your nearest Lionel Service Station can be found by calling 1-800-4-LIONEL or by accessing the website at [www.lionel.com](http://www.lionel.com).

If you prefer to send your Lionel product directly to Lionel, for repair you must FIRST call 586-949-4100 extension 2 or write to Lionel Customer Service, 6000 Victory Lane, Concord, NC 28027. Please have the 6-digit Lionel product number, the date of original purchase, the dealer where the item was purchased and what seems to be the problem. You will receive a return authorization (RA) number to ensure your merchandise will be properly tracked and handled upon receipt at Lionel LLC.

Once you have your Return Authorization (RA) number, make sure the item is packed in its original Styrofoam inner container which is placed inside the original outer display box (this will help prevent damage during shipping and handling). This shipment **MUST** be prepaid and we recommend that it be insured with the carrier of your choice.

Please make sure you have followed all of the above instructions carefully before returning any merchandise for service. You may choose to have your product repaired by one of Lionel LLC's Authorized Service Stations after its warranty has expired. A reasonable service fee should be expected once the product warranty has expired.

### Warranty Information

---

Please complete the information below and keep it, along with your **DATED ORIGINAL SALES RECEIPT**. You **MUST** present this form **AND** your **DATED SALES RECEIPT** when requesting warranty service.

\*A complete listing of Lionel Authorized retailers can be found by calling 1-800-4-LIONEL or by visiting our website at [www.lionel.com](http://www.lionel.com).

Products that are more than 3 years old, from date of manufacture, are not applicable for warranty coverage, even if they have never been sold prior to this date. (Under no circumstance shall any components or labor be provided free of charge.)

Name \_\_\_\_\_

Address \_\_\_\_\_

Place of Purchase \_\_\_\_\_

Date of Purchase \_\_\_\_\_

Product Number \_\_\_\_\_



© 2017 LIONEL L.L.C.  
6301 Performance Dr., CONCORD, NC 28027  
UNITED STATES OF AMERICA  
PRINTED IN CHINA