

dser

User Manual

RoboGeek 20T(R3720)

Table of Contents

01 Important Safety Information

Use Restrictions

Battery and Charging

04 Product Diagram

Robot

Accessories

Charging Dock

Remote Control

09 Operating and Programming

Notes Before Cleaning

Quick Start

How Robot Clean Your Home

Cleaning Schedule

17 Regular Robot Care

Emptying Robot's Bin

Cleaning Robot's Filter

Cleaning Robot's Side Brush

Cleaning Robot's Cliff Sensors and Charging Contacts

Cleaning Robot's Floor Tracking Sensor

Cleaning Robot's Extractors

Battery and Charging Information

23 Troubleshooting

26 Specifications

Important Safety Information

This appliance can be used by children aged from 8 years and above and persons with reduced physical, sensory or mental capabilities or lack of experience and knowledge if they have been given supervision or instruction concerning use of the appliance in a safe way and understand the hazards involved. Children shall not play with the appliance. Cleaning and user maintenance shall not be made by children without supervision.

The robot must be used in accordance with the directions in this Instruction Manual. Deepsea inc cannot be held liable or responsible for any damages or injuries caused by improper use.

To reduce the risk of injury or damage, keep these safety precautions in mind when setting up, using and maintaining your robot:

- Read all safety and operating instructions before operating your robot.
- Retain the safety and operating instructions for future reference.
- Heed all warnings on your robot, battery, charging Dock and in the owner's manual.
- Follow all operating and use instructions.



The symbol on the product or its packaging indicates:

Do not dispose of electrical appliances as unsorted municipal waste, use separate collection facilities. Contact your local authority for information regarding the collection systems available. If electrical appliances are disposed of in landfills or dumps, hazardous substances can leak into the groundwater and get into the food chain, damaging your health and well-being. Please contact your local or regional waste authority for more information on collection, reuse and recycling programs.

Use Restrictions

- Your robot is for indoor use only. Do not use the robot outdoor, commercial or industrial environments.
- Before using this device, pick up objects like clothing, loose papers, pull cords for blinds or curtains, power cords, and any fragile objects. If the device passes over a power cord and drags it, there is a chance an object could be pulled or a table or shelf.

- Your robot is not a toy. Do not sit or stand on this device. Small children and pets should be supervised when your robot is operating.
- Store and operate your robot in room temperature environments only.
- Do not use this device to pick up anything that is burning or smoking.
- Do not use this device to pick up spills of bleach, paint, or other chemicals, or anything wet.
- If the room to be cleaned contains a balcony, a physical barrier should be used to prevent access to the balcony and ensure safe operation.
- This appliance is not intended for use by persons (including children) with reduced physical, sensory or mental capabilities, or lack of experience and knowledge, unless they have been given supervision or instruction concerning use of the appliance by a person responsible for their safety.
- Children should be supervised to ensure they do not play with the robot. Cleaning and maintenance shall not be performed by children without supervision.
- Do not place anything on top of your robot.
- Be aware that the robot moves on its own. Take care when walking in the area that the robot is operating in to avoid stepping on it.
- Do not operate the robot in areas with exposed electrical outlets in the floor.

Battery and Charging

- Use only rechargeable battery packs with the correct specification approved by Deepsea.
- Charge using a standard outlet only. Product may not be used with any type of power converter. Use of other power converters will immediately void the warranty.
- Do not use a Charging Dock with a damaged cord or plug. If the cord or plug is damaged, it must be serviced by the manufacturer or similarly qualified persons.
- Always charge and remove the battery from your robot and accessories before long-term storage or transportation.
- Charge indoors only.

- Your robot's Charging Dock may be protected with a surge protector in the event of severe electrical storms.
- Never handle the Charging Dock with wet hands.
- Always disconnect your robot from the Charging Dock before cleaning or maintaining it.
- Please ensure voltage rating for enclosed Charging Dock matches standard outlet voltage.
- Used battery packs should be placed in a sealed plastic bag and disposed of safely according to local environmental regulations.
- Before every use, check the battery pack for any sign of damage or leakage. Do not charge damaged or leaking battery packs.
- If the battery pack is leaking, contact Customer Service for disposal.
- The battery pack must be removed from the robot before disposal.
- Do not crush or dismantle battery packs. Do not heat or place the battery pack near any heat source.
- Do not incinerate the battery pack. Do not short-circuit the battery pack.
- Do not immerse the battery pack in any liquid.

This device complies with Part 15 of the FCC Rules. Operation is subject to the following two conditions:

- (1) this device may not cause harmful interference, and
- (2) this device must accept any interference received, including interference that may cause undesired operation.

Product Diagram

Robot

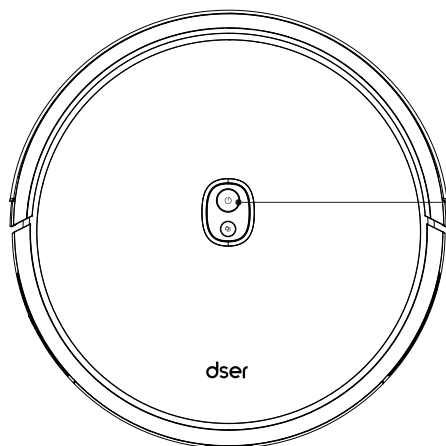

Power Button

Long press to turn on / off the robot, short press to pause and continue to work.

Indicator

Indicator Light Blue: Cleaning/ Standby Mode/ Full Charging

Indicator Light Orange: Self-Charging and Standby Mode under Low Power

Indicator Light Blinks Orange: Charging

Indicator Light off: Sleep Mode

Indicator Light or Blinks Red Accompanied with Sound Alarm: Troubleshooting

Auto-Charging Button

After pressing this button, the product automatically enters the recharge mode and looks for the charging seat for charging.

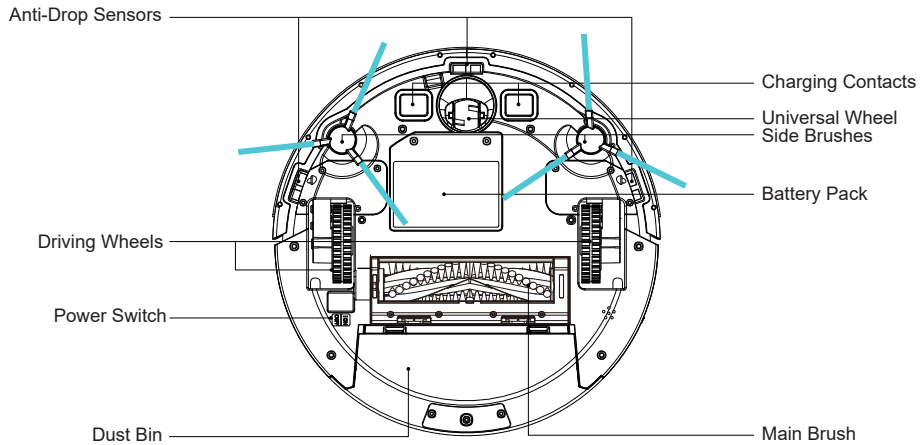
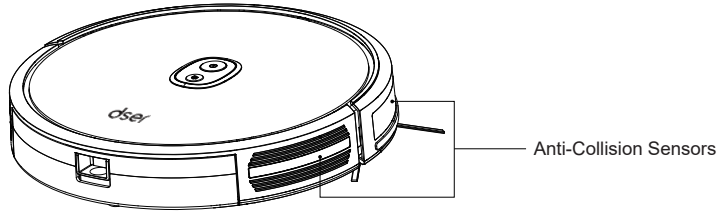

Accessories

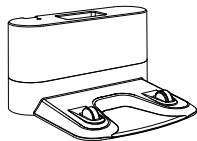

1 x Charging Dock

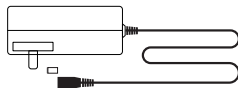

1 x Adapter



1 x Remote Control
(with 2 x AAA battery)

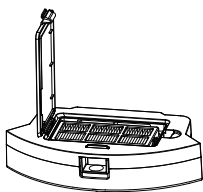

1 x Dust Bin

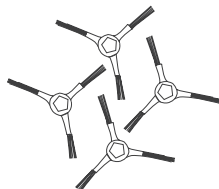

4 x Side Brushes

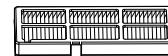

1 x Sponge Filter and
High Efficiency Filter

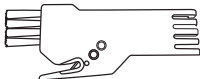

1 x Brush



2 x Boundary



Cable Ties (x5)

Charging Dock

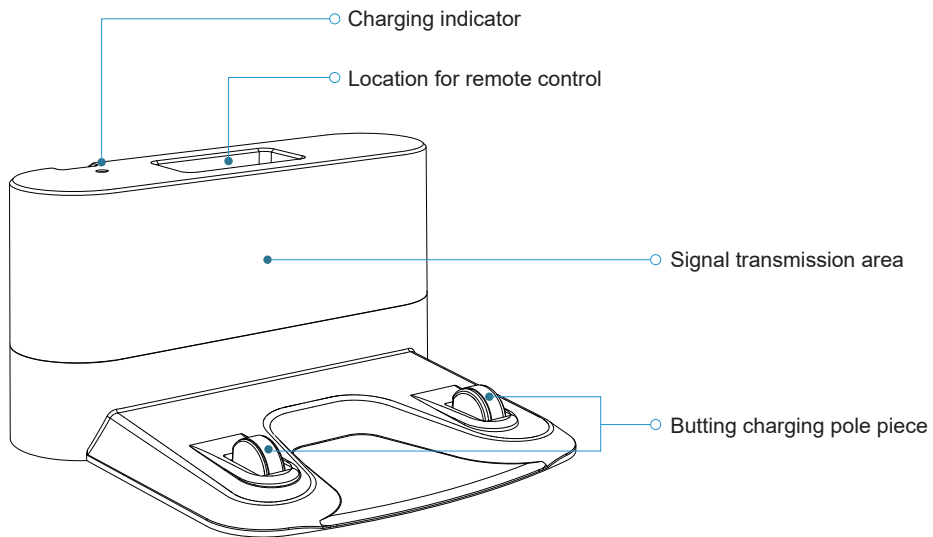

Remote Control

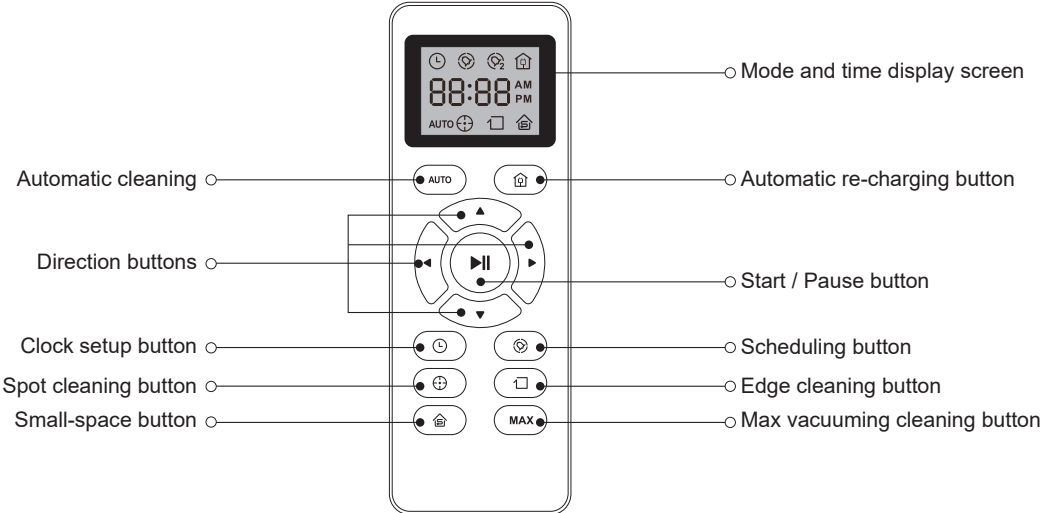

Operating and Programming

Notes Before Cleaning

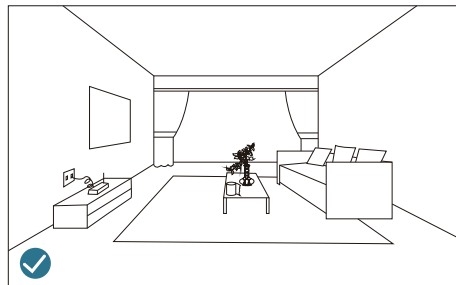
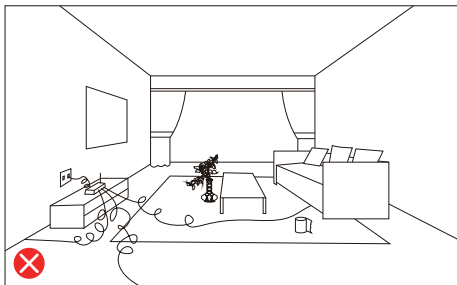

Before using Robot, pick up objects like clothing, loose papers, pull cords for blinds or curtains, power cords, and any fragile objects. If the Robot passes over a power cord and drags it, there is a chance an object could be pulled off a table or shelf.

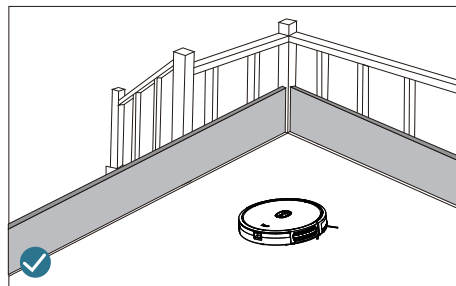
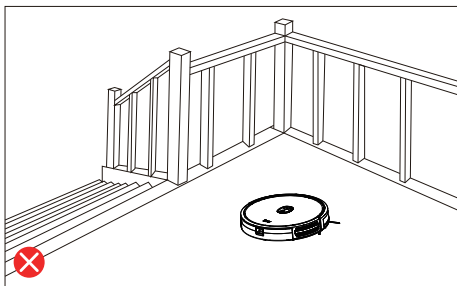

If the room to be cleaned contains a balcony, a physical barrier should be used to prevent access to the balcony and ensure safe operation.

Quick Start

1. Plug in the Charging Dock and place the remaining wire into the trunking at the bottom of the Charging Dock

Failure to place the remaining wire into the trunking, may cause Robot to become stuck while charging or cleaning.

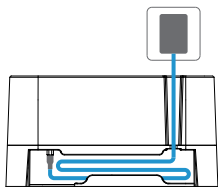

2. Place the Charging Dock on a hard level surface and against a wall.

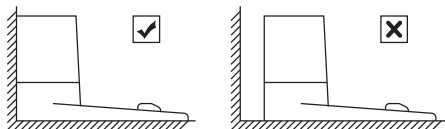

3. Charging Dock Position

Place the Charging Dock against the wall and make sure it is in an open and uncluttered area leaving at least:

- 2 meters (6 feet) in front of the Charging Dock.
- 1 meters (3 feet) on both sides of the Charging Dock.

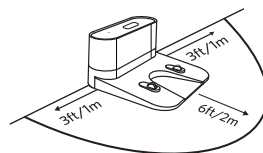

4. Install Side Brushes

Attach Side Brushes to the bottom of Robot by pressing a brush into each slot until it clicks.

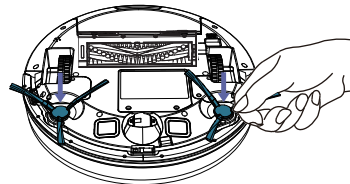

5. Activate the Robot



Place Robot onto the Charging Dock, making sure the metal charging contacts on the Charging Dock match up with those underneath the robot.

Initial Use, Switch on the Power Button on the Bottom.

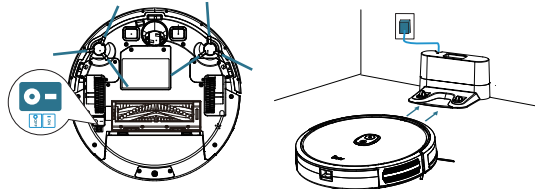
If successful, you will hear a series of tones. Once the  Power button illuminates, Robot is ready for use.



6. Start Cleaning Cycle

- Press the  power button once to wake up the robot.
- Press the  power button again to start a cleaning cycle (or  button on Remote Control).



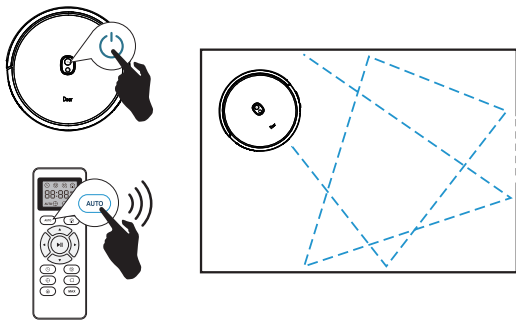

If its battery gets low before finishing a cleaning cycle, robot returns to the Charging Dock to recharge.

If the Charging Dock is inaccessible, Robot will not be able to recharge, please place the robot manually on Charging Dock for charging. **(Refer Activate the Robot)**

Please refer to section 3.3 for more Cleaning Mode.



7. Pause

- To pause the robot during a cleaning cycle press the  button on robot or press the  button on the Remote Control.
- To resume the cleaning cycle, press  button again.
- To send robot back to the Charging Dock, press  button on the Remote Control.

The actions listed above can also be managed from the Remote Control.

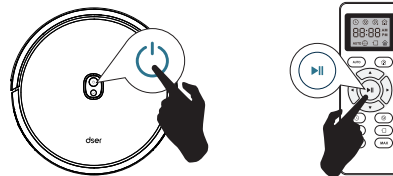

8. Power OFF

- To end the cleaning cycle and put robot in standby mode, press and hold  button until robot's indicators turn off.

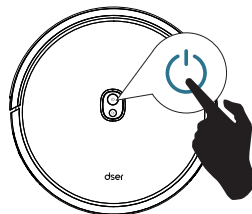

3.3 How Robot Clean Your Home

Robot continues this process until it has cleaned an entire level of your home. If its battery gets low before finishing a cleaning cycle, Robot returns to the Charging Dock to recharge.

1. Auto Cleaning

- At the start of a cleaning cycle, Robot will clean your home efficiently.
- At various times throughout the cleaning cycle, Robot touches up around the edges of the room, as well as chair legs and other furniture.
- Robot continues this process until it has cleaned an entire level of your home. If its battery gets low before finishing a cleaning cycle, Robot returns to the Charging Dock to recharge.
- Once Robot finishes its cleaning cycle, Robot returns to the Charging Dock to recharge.

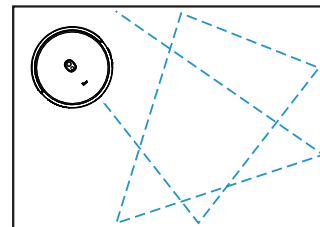
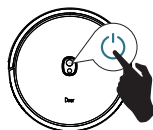

2. BoostGen Tech

Support BoostGen Tech, when a carpet or other hard-to-clean place is detected, suction is increased to 1600pa. Once leave this kind of hard-to-clean place, the robot cleaner returns to normal mode.

Cleaning Preferences

3. Spot Cleaning

When you select Spot Cleaning, robot intensely cleans a localized area by spiraling outward about 3 feet (1 meter) in diameter and then spiraling inward to where it started. When Spot Cleaning, robot boosts its vacuum power to provide the best cleaning possible where you need it. To use Spot Cleaning, place robot on top of the localized debris and press  (Spot) on the Remote Control.

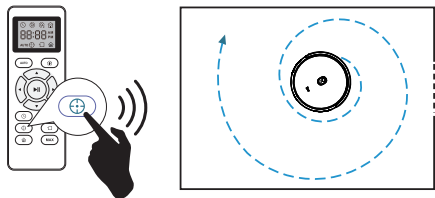

4. Max Vacuuming Cleaning

Robot increases its vacuum power to provide a deeper clean when press the  button on Remote Control, Max Vacuuming Cleaning is Off by default.

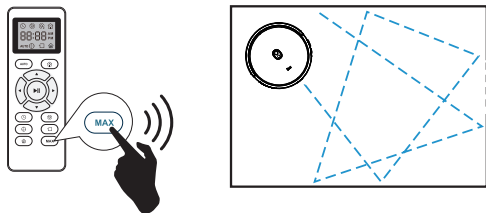

5. Edge Cleaning

After robot finishes cleaning the open areas of your floor, it uses Edge Clean to ensure that it has cleaned along walls and around furniture legs. If you prefer a quicker edge cleaning, press the  button on Remote Control.

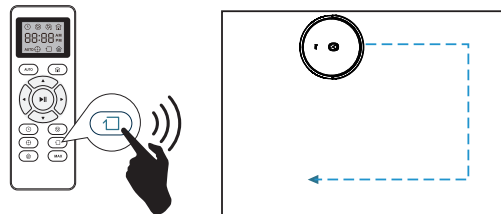

6. Single Room Cleaning

intensively cleans one single room and stops after 30 minutes. Select this mode only when one specific room needs to be cleaned. Make sure to confine the cleaner to the room by closing the door.

Press  on the remote control to start cleaning in Single Room Mode.

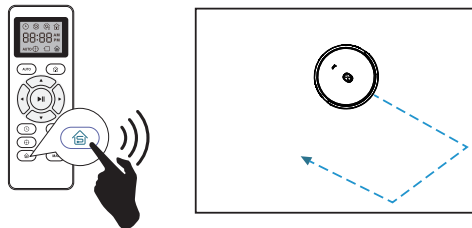

7. Manual Cleaning

You can direct Robot to clean a particular area by using the directional buttons on the remote control.

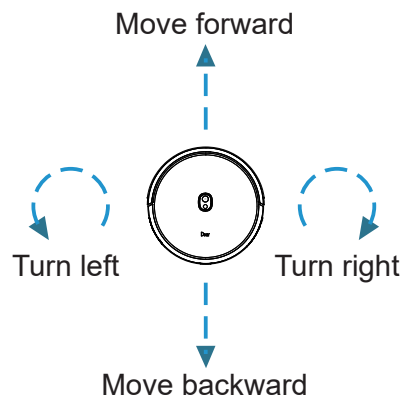
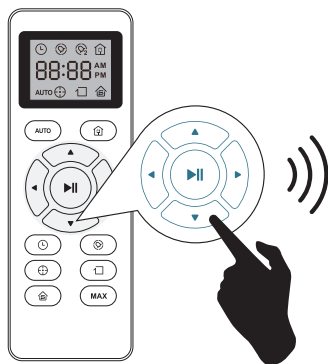



Cleaning Schedule

The cleaner has cleaning schedule settings which allow you to customize when Robot cleans your home. These settings are available only through the Remote Control.



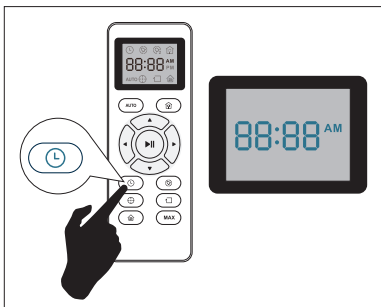

Note: Please make sure the Remote Control near by the Robot while setting the Clock or Schedule.

1. Set the Remote Control's Clock

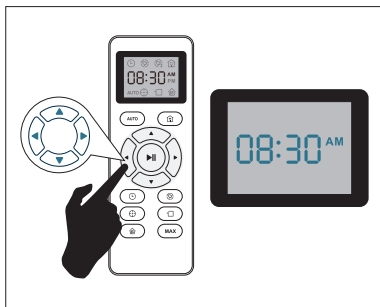

Press  button on Remote Control, and then the hour section begins to flash in the clock display setting window.



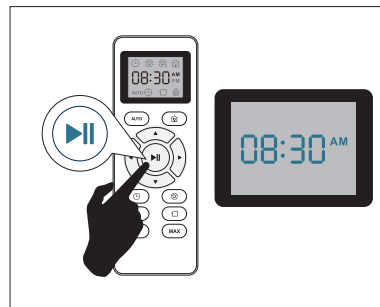

Press  or  button to select the desired figures. Press the  or  button to select the minute or hour section.





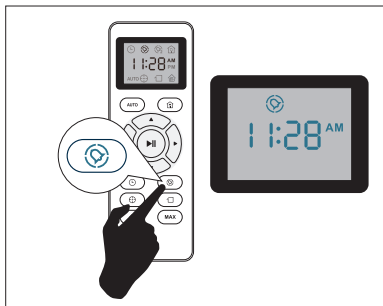

And then press the  button, the Robot will "BEEP" when the clock setting completed.

2. Setting Cleaning Schedule

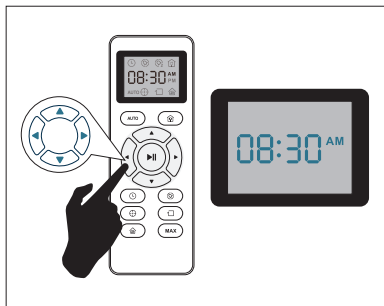

Press  button on Remote Control, and then the hour section begins to flash in the Cleaning Schedule display setting window.



Press  or  button to select the desired figures. Press the  or  button to select the minute or hour section.

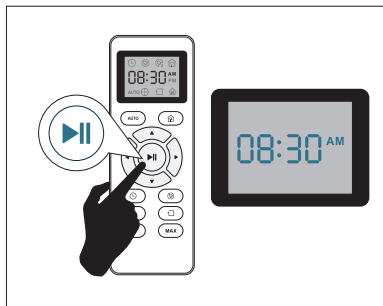

And then press the , the Robot will "BEEP" when the Cleaning Schedule setting completed.

3. Cancel the Cleaning Schedule

Press and hold  button approximately 4 seconds on Remote Control, the Robot will "BEEP" when the Cleaning Schedule process cancel completed.

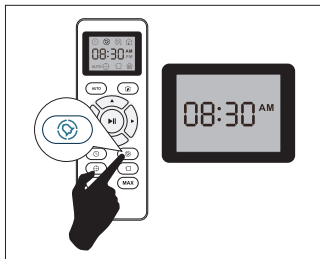

Regular Robot Care

To keep robot running at peak performance, perform the following care procedures. If you notice robot picking up less debris from your floor, then empty the bin, clean the filter and clean the extractors.

Robot Part	Care Frequency	Replacement Frequency
Filter	Once per week (twice per week in homes with pets)	Every 2 months
Cleaning Cloth (Sold Separately)	After each use	Every 2-4 months
Extractors	Once every 4 months (once every 3 months in homes with pets)	Every 6-12 months
Dust Bin	After each use	—
Water Tank (Sold Separately)	After each use	—
Front Caster Wheel Side Brush Cliff Sensors Charging Contacts Floor Tracking Sensor	Once per month	—

Robot manufactures various replacement parts and assemblies. If you think you need a replacement part, please contact [Customer Care](#) for more information.

Emptying Robot's Bin

1. Press bin release button to remove bin.

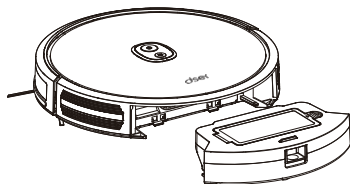

2. Open bin door to empty bin.

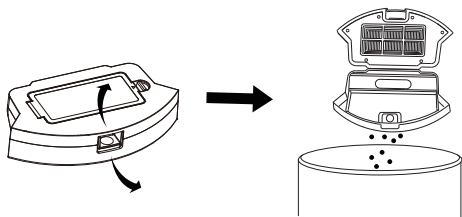

Cleaning Robot's Filter

1. Remove filter by grasping the white tab.

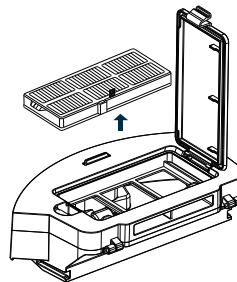

2. Shake off debris by tapping the filter against your trash container.

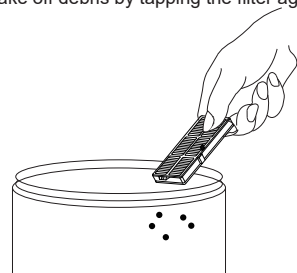

Cleaning Robot's Side Brush

1. Remove the brush
2. Clean the brush and the brush post, and reinstall the brush.

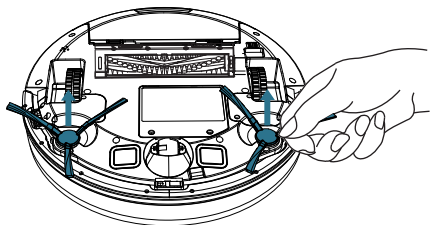

2. Wipe the charging contacts on Robot and the Charging Base with a clean, dry cloth.

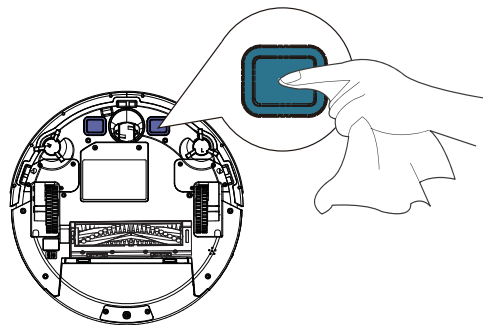

Cleaning Robot's Cliff Sensors and Charging Contacts

1. Wipe Robot's Cliff Sensors with a clean, dry cloth.

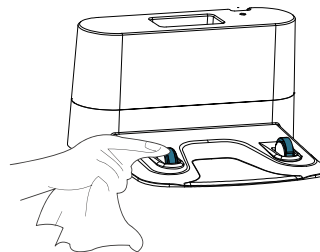
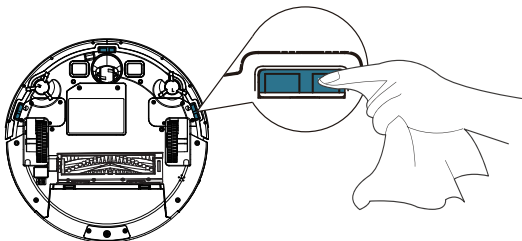

Cleaning Robot's Floor Tracking Sensor

Use a clean, dry microfiber or soft cotton cloth to wipe any debris that has accumulated in the round sensor opening on the right side of the bottom surface. Do not spray cleaning solution directly into the sensor opening.

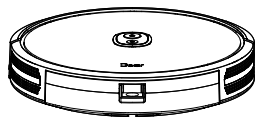

Cleaning Robot's Extractors

1. Pull on the release tabs to unlock the brush guard as shown.

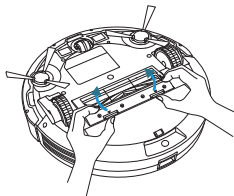

2. Lift the rolling brush to remove.

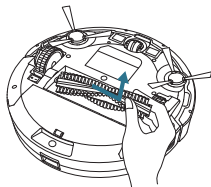

3. Clean the rolling brush with the provided cleaning tool or a vacuum cleaner.

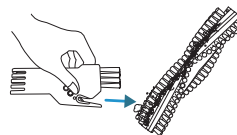

4. Reinstall the rolling brush by inserting the fixed protruding end first and then clicking into place.

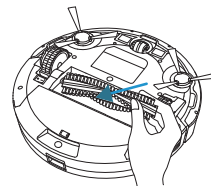

5. Press down to snap the brush guard into place.

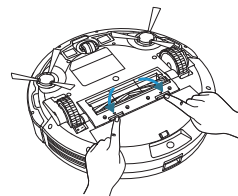

Battery and Charging Information

Remove the extractors. Remove any hair or debris that has collected underneath the caps and around the axles.

Lithium Ion Battery

Important: Lithium ion batteries and products that contain lithium ion batteries are subject to stringent transportation regulations. If you need to ship this product (with the battery included) for service, travel or any other reason, you **MUST** comply with the following shipping instructions:

- Remove the lithium ion battery from the product
- Place a piece of tape over the battery's metal charging contacts
- Reinstall the battery (with the tape on it) in the product and secure the battery door
- Package the product in its original packaging or in your own packaging that prevents any movement during transportation
- Ship via ground transportation only (no air shipping)

Battery Charging

To extend battery life, always keep robot charged on the Home Base when not in use.

Battery Storage

If storing robot off of the Charging Dock, remove the battery first. Then store robot and the battery in a cool, dry place.

Battery Disposal

Contact your local waste management authority for battery recycling and disposal regulations in your area.

Battery Replacement

You can visit dser's website: www.dserlife.com to purchase the battery or other accessories for the robot.

Battery Removal

Follow these instructions to remove and reinstall robot's battery:

1. Unscrew the door and the two screws on the battery door, then remove.

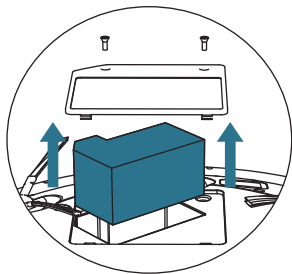
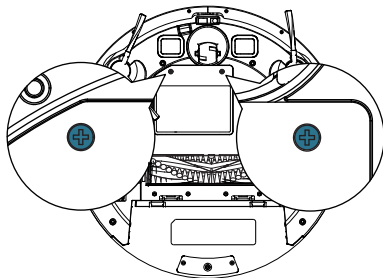

2. Reinstall the battery with the battery label and tabs facing up.

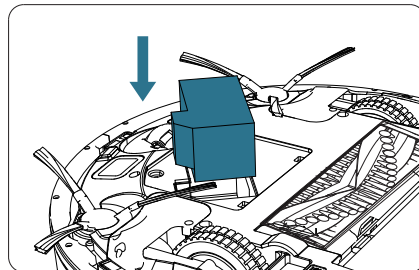

3. Reinstall the battery door and the two screws. Take care not to pinch the side brush in the battery door when re-installing the battery.

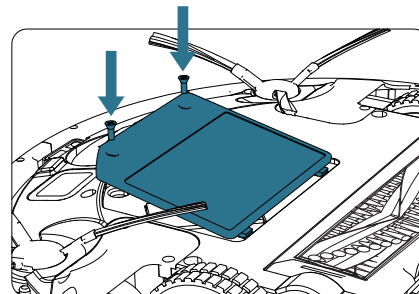

Troubleshooting

Robot will tell you something is wrong with a two-tone distress sound followed by message. The indicator  will also blink or lit red. Refer to the chart as below to resolve Robot's problem. If the problem is not resolved, please contact our COST FREE customer service team for more assistance.

Rebooting Instructions

For some errors, rebooting Robot may resolve the problem. To reboot Robot, press the power button on the bottom on Robot, you will hear an audible tone signifying a successful reboot.

Indicator Liting Red

Robot Blinks and Says		Likely Cause	What to Do
Indicator Liting Red	One beep	Front caster wheel is stuck	Clean the front caster wheel and press the power button to restart the Robot.
	Two beeps	Robot's side brush may stuck	Clean the side brush and press the power button to restart the Robot.
	Three beeps	Robot's vacuum fan is stuck or its filter is clogged.	Remove and empty Robot's bin. Clean Robot's filter. Then, briskly tap the bin to loosen any remaining trapped debris.
	Four beeps	Robot's main extractors can't turn.	Remove and clean Robot's extractors and caps.

Indicator Flashing Red





Robot Blinks and Says		Likely Cause	What to Do
Indicator Flashing Red	One beep	<ul style="list-style-type: none"> • Robot is stuck and one of the wheels is not making contact with the floor(hanging in mid-air). • Robot may be in an extremely large room and the bumper is not registering obstacles. 	Restart cleaning in a new location.
	Two beeps	Robot is stuck.	If Robot is stuck, free it and start in a new location. Clean Robot's side wheels of hair and debris. Push the wheels in and out, and check that they both turn freely.
	Three beeps	Robot's cliff sensors are dirty, it is hanging over a drop, or it is stuck on a dark surface.	If Robot is hanging over a drop, or on a dark surface, start in a new location. Otherwise, wipe its cliff sensors with a dry cloth.
	Four beeps	Robot cannot return to its Charging Dock or starting position.	Ensure there are no obstacles in front of the Charging Dock or starting position. Wipe the Charging contacts on both the Charging Dock and robot with a clean, dry cloth.

Frequently asked questions

Problems	Solutions
cannot be activated.	<ul style="list-style-type: none"> • Make sure the main power switch is in the ON position. • Make sure the battery is fully charged. • Replace the batteries (2 AAA) in the remote control. • Make sure the remote control is within range (16 ft/5 m) of Robot. • If you still have trouble, turn off the main power switch and then turn it back on.
The remote control does not work.	<ul style="list-style-type: none"> • Replace the batteries in the remote control. • Make sure Robot is turned on and fully charged. Note: Limited workable range distance is 5m/16.5ft.
stops working suddenly.	<ul style="list-style-type: none"> • Check if Robot is trapped or stuck on an obstacle. • Check if the battery level is too low. • If you still have trouble, turn off the main power switch, wait for 2 seconds, and then turn it back on.
You cannot schedule cleanings.	<ul style="list-style-type: none"> • Make sure the main power switch on the bottom of Robot is turned on. • Make sure the time, time of day (AM/PM), and the scheduled time have been set correctly. • Check if Robot power is too low to start cleaning.
Suction power is weak.	<ul style="list-style-type: none"> • Check if any obstructions are blocking the suction inlet. • Empty the dust collector. • Clean the filters with a vacuum cleaner or a cleaning brush. • Check if the filters are wet due to water or other liquid on the floor. Air-dry the filters completely before use.
cannot be charged.	<ul style="list-style-type: none"> • Check if the indicator on the Charging Base lights up. If not, contact the service center to repair or replace the Charging Base. • Dust off the charging contact pins with a dry cloth. • Check if you can hear a beep when Robot is docked onto the Charging Base. If not, contact the service center to repair or replace the Charging Base.

Problems	Solutions
Robot cannot return to the Charging Base.	<ul style="list-style-type: none"> Remove objects within 3 ft/1 m to the left and right side and within 6 ft/2 m of the front of the Charging Base. When Robot is in the vicinity of the Charging Base, it will return more quickly. However, if the Charging Base is located far away, Robot will need more time to return. Please be patient as it works its way back. Clean the charging contact pins.
The rolling brush does not rotate.	<ul style="list-style-type: none"> Clean the rolling brush. Check if the rolling brush and brush guard have been installed properly.
Robot's movements or travel path are abnormal.	<ul style="list-style-type: none"> Clean the sensors carefully with a dry cloth. Restart Robot by turning the power switch off and on.

6 Specifications

	Product Model	R3720
	Input	19 V  0.6 A
	Battery Voltage	DC 14.4 V
	Power Consumption	28 W
	Battery Type	DC 14.4 V Li-ion 2600 mAh
	Dust Collector Capacity	0.6 L
	Cleaning Time	Up to 100 mins
	Charging Time	300 - 360 mins
	Input	19 V  0.6 A
	Output	19 V  0.6 A

6. Use the Boundary Strip

With the Boundary Strip, you can keep Robo away from any area or item you do not want Robo to clean. the cleaner will recognize the Boundary Strip and will not cross into the blocked-off area.

1. Identify the area or item you do not want the cleaner to get close to.
2. If necessary, use scissors to cut the Boundary Strip to a shorter length. Be sure to correctly measure the length before cutting.

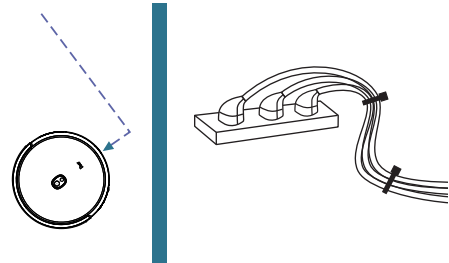
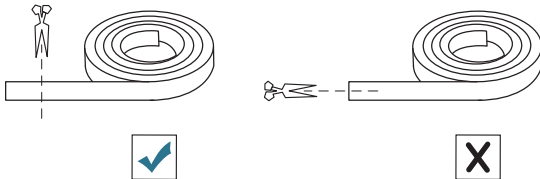

Note: If the Boundary Strip is rolled up, remove and then re-apply on the floor with adhesive tape. Otherwise the Boundary Strip may not work well.

Make sure the Boundary Strip is placed on the same surface plane the cleaner is used on.

Be careful not to damage the floor when using adhesive tape. It is not recommended for use on carpets.

Keep the Boundary Strip away from objects that emit excessive heat.

3. Apply the supplied strips of adhesive tape to lay the Boundary Strip flat on the floor. Make sure the strip is placed FLAT on the floor or under an area rug.

**For FAQs and more information,
please visit www.dserlife.com.**

E-mail: support@dserlife.com

Ins: [@dser_offical](#)

Facebook: [@dserlife](#)

YouTube: [@dserlife](#)

Twitter: [@dserlife](#)
