



Gourmia

MODEL# GTC8000

TEA-SQUARE
PERSONAL BREWING SYSTEM





Welcome to the natural purity of *fresh-brewed* tea!

Brewing tea is more than simply an art; it is a signal. It tells you there is a moment of pure serenity ahead. You may sip a hot cup of freshly brewed tea first thing in the morning, during your mid-morning energy break, on a cold winter's afternoon or with a special dessert. Whatever the time, the simple purity of fresh, home brewed tea invites you to take a moment to relax.

Following the newest trend of brewing loose leaf teas at home, Gourmia has selected the perfect way for you to brew tea with ease and convenience: introducing Tea-Square, your own personal brewing system!

Gourmia's exclusive Boil to Brew technology starts by adapting a centuries-old practice to awaken and refresh the loose tea leaves. When the Refresh button is selected, a small amount of water is heated in the system and poured over the tea leaves in the glass chamber. This first step rinses and refreshes the leaves for the fast infusion cycle to follow. After selecting your choice of Light, Medium or Strong tea, the system automatically brews your tea to perfection.

At the end of this simple process, your fresh cup of tea is a thoughtful reminder of elements from the earth: fresh tea leaves, pure water and nature's clear glass.

In addition to the satisfying results in brewing fresh loose leaf tea, you will find that the beauty and style of the Tea-Square on your counter will invite compliments from all who view it. Be prepared to make more tea!

Inside these pages, you'll find information about the Tea-Square, including assembling, operating and maintaining this system, and in addition, you'll also find tips about specialty teas, tea blends, herbal teas for wellness and recipes to create your own blends. Enjoy!

© 2016 Gourmia
www.Gourmia.com
The Steelstone Group
Brooklyn, NY

All rights reserved. No portion of this manual may be reproduced by any means whatsoever without written permission from The Steelstone Group, except for the inclusion of quotations in a media review.

Although every precaution has been taken in the preparation of this manual, The Steelstone Group assumes no responsibility for errors or omissions. Nor is any liability assumed for damages resulting from the use of the information contained herein. Although every effort has been made to ensure that the information contained in this manual is complete and accurate, The Steelstone Group is not engaged in rendering professional advice or services to the individual consumer; further, The Steelstone Group shall not be held responsible for any loss or damage allegedly arising from any information or suggestion in this manual.

10 9 8 7 6 5 4 3 2 1

Printed in China

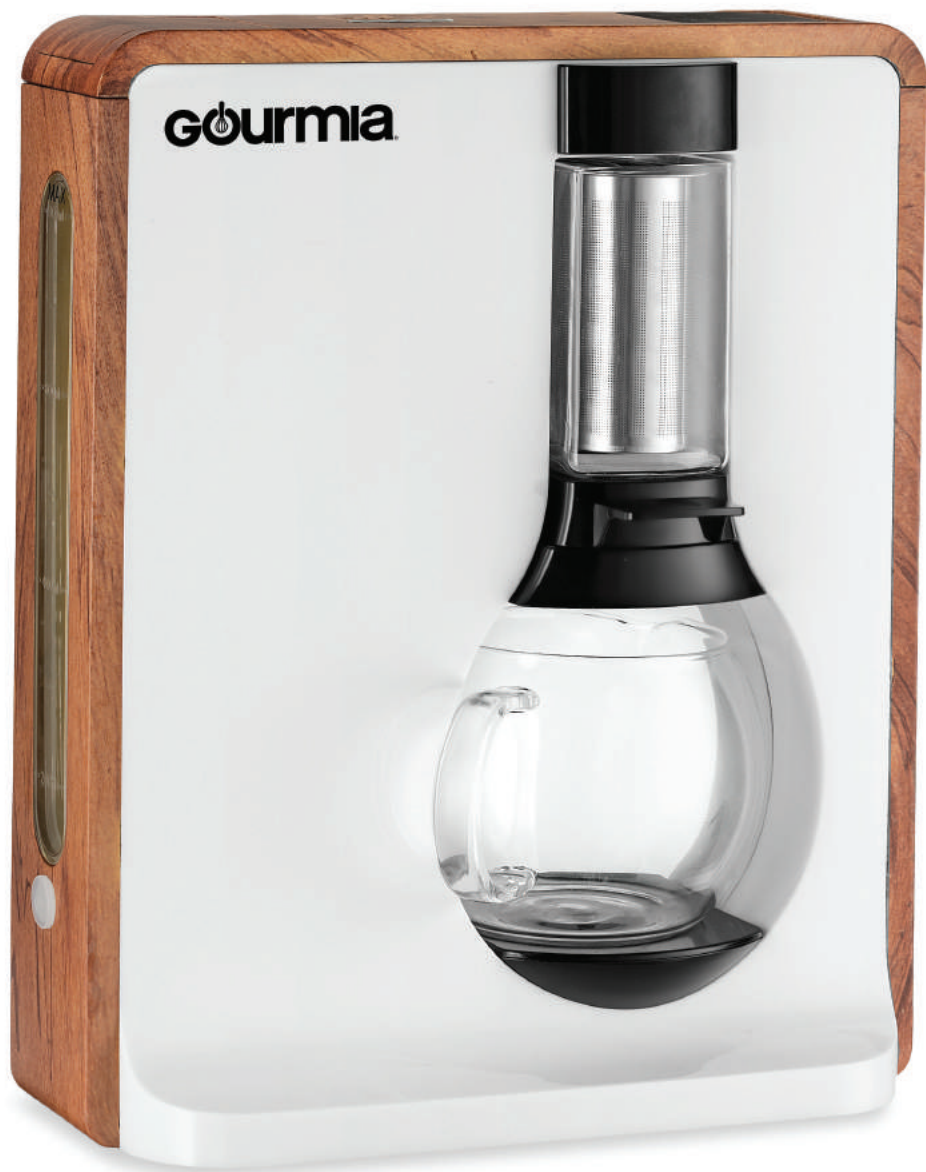

THE MEANING OF TEA: TRENDS & TYPES P. 6

SAFETY INFORMATION p. 12

FEATURES & FUNCTIONS p. 15

BEFORE FIRST USE & ASSEMBLY p. 19

BREWING YOUR CUP OF TEA p. 21

SPECIALTY BLENDED TEA RECIPES p. 23

MAINTENANCE & SERVICE p. 26

THE MEANING OF TEA: TRENDS & TYPES

What is tea-drinking all about? When introduced to one's first cup of tea, the initial sense might be one of a strong or even bitter flavor. But, there must be something quite unique and especially good about tea, as it is the second most-consumed liquid globally, coming in just behind water in recent studies. To determine where the practice of preparing and drinking tea started, an historical check must span several countries, many decades and numerous differing accounts of where the practice of drinking tea leaves first started.

One story often told is that tea was discovered in 2737 BC by the Chinese Emperor Shen-Nung, who was also known as the "Divine Healer." The legend says that tea leaves accidentally blew into the Emperor's pot of boiling water and thus, hot tea was born. One verified discovery noted: In the third century AD, a reference to tea was made by Hua Tao in a medical text. These first few accounts give us a clue to the true purpose of tea: to help and to heal.

For hundreds of years, tea was obtained only through Asian channels and that made it scarce and exotic, so much so that it was used as a monetary form in various countries. In the early Industrial years in Europe, only the best East India tea graced the tables of genteel men and women, while more common black teas were consumed in working family households. In Asia, tea has long been an established ritual, signifying much more than the preparation of a simple beverage. The serving of tea designated the social status of the upper class families and allotted an improved social standing to those who served tea with impeccable taste and grace.

In today's world, tea is still a much-beloved beverage, trending in popularity more than ever, as people around the world long for the simple relaxation of a comfortable chair and a hot cup of tea. The practice of brewing loose leaf tea continues to spread globally with great enthusiasm by millions of tea lovers.

What are the properties of tea that make drinking it so desirable? The five senses can quickly answer that question: the warmth in holding a tea cup can heat chilled fingers, the taste of sweet tea brings energy, the sight of a steaming cup of tea encourages the heart, the smell of mint tea soothes the stomach, and the sound of tea being poured into your glass carafe brings pure anticipation.

Many people wonder about the health benefits of drinking tea and whether or not tea is a good-for-you beverage. To answer this question, you'll want to note



which type of tea you use, how often you drink tea, how much caffeine is in your tea and whether there are other ingredients in your blended teas. There are so many types of tea, the properties of each can only be examined by looking at labels and making a personal assessment. The truth is, however, that many teas contribute to your good health. The following list of elements commonly found in tea contains the building blocks of good health: antioxidants, phytochemicals, flavonoids, flavonols, epigallocatechin gallate, and theanine. One of the most important benefits of drinking tea is that it hydrates your body, which is a critical component of a good metabolism.

When considering the comfort of drinking tea and how you'd like to include tea in your lifestyle, there are over 3,000 types of tea from which to choose! This count doesn't even include numerous blends and specialty types of teas, including flowering tea blooms. Specialty ingredients and herbal components add to the complexity of your choices: matcha tea, maté tea, herbal medicinal teas and many more condition-specific blends are available. However, the idea behind each type is the same; add hot water and allow the tea to "help and to heal."

Why use loose tea leaves; why not simply use a tea bag? The answer depends on you. Tea bags are certainly convenient and more common than loose teas. However, the flavor in tea bags is less intense because the tea has been dried and oxidized in more refined processes and then the bags sit on shelves until purchased. By the time a tea lover pours water over a tea bag, many months may have passed since the tea was fresh.

There are four main types of tea leaves: white, green, oolong and black. Surprisingly, each type originates from the same plant, *Camellia sinensis*. If all types of tea come from one plant, what creates the difference in flavor and appearance? The difference in these areas comes from the way the leaves are withered, processed, and the length of time the leaves have been oxidized. Herbal teas, or "Tisanes" are not compounded from the same plant as the four types, but are made from flowers, fruit, herbs and seeds. The following is a brief overview of the most popular types of tea and trending choices for loose leaf tea.

* White tea, the most mild of all teas, has a natural sweetness and has been found in some studies to promote youthful elastin and collagen in skin. White tea is known for the antibacterial and antiviral properties it contains.

This fragile tea should be brewed using the Light strength for best results. The caffeine factor is lower than other teas, probably because the tea leaves are not processed.

Popular White Teas: Silver Needle, White Peony

* Green tea is also fairly low in caffeine and is dried only minimally. The leaves are oxidized, however rapid heat is applied to stop the process, allowing only a short oxidization process.

Green tea is popular due to studies that have shown this tea to act as a task force that eliminates free radicals in the body. Green tea can be brewed using Light or Medium strength. Green tea has subtle flavors and is often partnered with citrus fruit to build a stronger flavor profile.

Popular Green Teas: Sencha, Dragon Well, Gunpowder

* Oolong tea has a moderate amount of caffeine and is oxidized more than green tea and less than black tea. The caffeine content is equally between that of green tea and black tea. Oolong tea has a fruity or tropical flavor and is commonly paired with fruit and spices for aromatic flavor combinations.

Studies have shown that oolong tea may help reduce cholesterol and promote weight loss by boosting metabolism. Green teas can be brewed using the Medium or Strong settings.

Popular Oolong Teas: Wu-Yi, Red Robe, Cassia





* Black tea is used most commonly in the Western hemisphere; less so in Asian countries. The caffeine content is higher than other teas and black tea has been oxidized for the longest period of time in comparison to other teas. Black tea can carry a slightly bitter flavor, but when paired with citrus, fruit or spices, it recedes and associates with other flavors nicely.

Black tea has proven in studies to be an assistant in thinning the blood and is packed with antioxidants. Black tea should be brewed using the Medium or Strong settings.

Popular Black Teas: English Breakfast, Earl Grey, Keemun, Darjeeling, Chai (blend)

* Herbal Teas (Tisanes) are made from herbs, spices, flowers, fruit and seeds. Although these teas are not technically “tea,” they provide many of the health-promoting benefits sought by tea lovers. Brew these teas on the Light or Medium setting unless directed otherwise.

Popular Herbal Teas: Chamomile, Echinacea, Mint, Rooibos, Lemon & Ginger, Hibiscus

Is it true that drinking tea can boost a healthful lifestyle? The short answer is, “Yes!” Tea is a gentle stimulant and can assist in helping the brain actively work. When other ingredients, such as ginger, echinacea, dried berries or citrus fruit, are added, tea takes on additional healthful properties, such as an antioxidant boost, a cold and flu reducer, a detox boost, and other helpful roles in healthful living. Teas are active in the body, so before drinking proprietary tea blends or herbal teas, check to determine that they do not interact with medications or other foods consumed.

Check out the Specialty Tea Blended Recipes we offer in this guide (p.xx) and create your own favorite blends using the Tea-Square brewing system. As you enjoy your next cup of tea, remember the true power of tea; to “help and to heal.”

IMPORTANT SAFEGUARDS

When operating this electric appliance, basic safety instructions should always be followed. Refer to the following for these instructions.

1. **READ ALL SAFETY & USAGE INSTRUCTIONS BEFORE USING TEA-SQUARE BREWING SYSTEM.**
2. **EXERCISE CAUTION:** Do not immerse cord, plug or the Tea-Square Base in water or other liquid.
3. Hot steam escapes through the Steam Vent while the Tea-Square is operating. Keep hands and face away from the Vent.
4. Do not use liquids or ingredients in the Tea-Square other than those intended, as it may cause fire and/or short circuit damage.
5. Unplug the Tea-Square from outlet when not in use or before cleaning. Allow the Tea-Square to cool before cleaning. Do not let cord hang over edge of table or counter or touch hot surfaces.
6. Children should not use the Tea-Square; close supervision is required when appliance is used near children.
7. Operate the Tea-Square on a level surface well away from any hot gas or electrical burner, heat source, combustible spray cans or pressurized items.
8. Never operate the Tea-Square with a damaged cord or plug or one that has malfunctioned or been damaged in any way. Immediately contact Customer Service for analysis.
9. **DO NOT** add unauthorized accessory attachments. Such use may result in electric shock, injury or fire.
10. Do not use the Tea-Square for any use other than intended. Do not use on a stovetop.

SAVE THESE INSTRUCTIONS

FOR HOUSEHOLD USE ONLY



3 Conductor Cord Set: This appliance is equipped with a 3-conductor cord set that has a 3 prong grounding-type plug. It should be properly connected to a grounding-type outlet. The plug is designed to fit **ONLY** a 3-grounding outlet unit, and as such, the grounding prong should never be removed. If needed, purchase a 2-prong adaptor and ground it to the outlet. Consult a qualified electrician if in doubt. Do not use an adaptor unless you are confident it is grounded. Do not modify this plug. If the plug does not fit the outlet securely, call a qualified electrician for assistance.

WARNING: This product contains a chemical known to the State of California to cause cancer.

WARNING: This product contains a chemical known to the State of California to cause birth defects or other reproductive harm.



FEATURES & FUNCTIONS

A. Tea-Square Base: The sleek and elegant Base is enclosed in a distinctive wood-style panel that evokes all the natural elements of the earth. The Base houses the unique Boil to Brew heating system, glass tea chamber, stainless steel strainer, glass serving carafe, pre-programmed control panel and water tank.

The delicately designed Steam Vent opens on the top of the Base panel and while in operation, hands and face should be kept away. The glass carafe sits on the black Sensor Plate, which is part of the safety system. If the glass carafe is not on the Sensor Plate, the tea brewing system will not start.

B. Glass Tea Chamber: The Glass Tea Chamber and Extra Fine Stainless Steel Strainer are components of the finest tea filtering systems worldwide. The glass chamber holds the heat and resists impurities, while the extra fine stainless steel strainer traps the smallest pieces of loose tea. Together, they are a pure conduit for the hot water as it filters through the stainless steel strainer, infuses the tea and flows into the glass carafe.

C. Extra Fine Stainless Steel Strainer: This beautifully crafted strainer will hold a generous amount of loose tea leaves and, most importantly, will trap them effectively while hot water filters through them. The very fine mesh of this strainer holds even the smallest particles of tea and the stainless steel components in this strainer also ensure durability for endless cups of pure tea.

D. Glass Serving Carafe: Sparkling glass, one of earth's most beautiful elements, showcases tea like no other vessel. In addition to the beauty of this glass carafe, it is also designed to reduce impurities and off-flavors that accumulate in other types of carafes and tea pots. This carafe holds up to 4 cups of fresh-brewed tea and rests on the Sensor Plate of the Base.

E. Water Tank: With the lid cleverly built into the wood-style Base Panel, the Water Tank almost invisibly holds up to 4 cups water. Pour enough water into the tank to fill above the MIN line in the clear window and do not overfill with water past the MAX line in the same window.

The water tank contains a discreet Drain Plug, located on the bottom of the side panel. See Maintenance (p. xx) for directions on removing the Drain Plug.

F. Pre-programmed Control Panel With choices for Refresh, Light, Medium or Strong brewed tea and a safety system warning, the Control Panel handily covers all the functions of the Tea-Square personal brewing system.



FEATURES & FUNCTIONS

A. Start button: Press to Start the system operation. Press to Stop any operation at any time.

B. Refresh button: Press to begin the Refresh function before brewing tea. After pressing the Refresh button, a small amount of water is heated in the system and filtered over the tea leaves in the glass chamber. This first step rinses and refreshes the leaves for the fast infusion cycle to follow.

C. Lack Cup: If the glass carafe is not resting on the Sensor Plate when the system is positioned to start brewing, this light will turn red and delay the operation until the carafe is in place.

D. Light: Choose the Light button if you want very mild tea and a reduced amount of caffeine in your tea. White tea should always be brewed using the Light cycle, as should other tea blends that contain fragile ingredients. This cycle is the shortest and impacts the tea leaves lightly.

E. Medium: The Medium brew button will brew most teas with great success. The strength of the tea will be between Light and Strong and the flavor will be well-developed, without being pronounced. The Medium button will cycle longer than the Light button and shorter than the Strong button and will impact the tea leaves in a moderate, balanced fashion.

F. Strong: When brewing black tea or black tea blends, select this button for best results. The Strong cycle is also the longest and the loose tea leaves will be most impacted by this cycle. Press the Strong button when you desire to taste the full or complex flavors of your tea.



BEFORE FIRST USE & ASSEMBLY

1. Before using the Tea-Square for the first time, wipe the exterior of the Base with a damp cloth and mild soap. Dry with a soft towel.
2. In warm, sudsy water, clean the glass carafe, glass chamber and strainer. Dry well.
3. Pour up to 4 cups clear or filtered water into the Water Tank.
4. Plug the Tea-Square cord into the wall outlet. The Start button will illuminate in red.
5. Press the Start button again. The button will turn blue to indicate it is in Stand-by Mode.
6. The Lack Cup button will illuminate in red to indicate that the glass carafe is not in position on the Sensor Plate. This is part of the safety system of this unit.

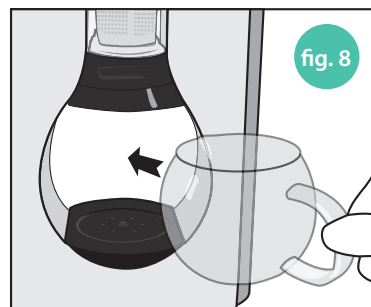
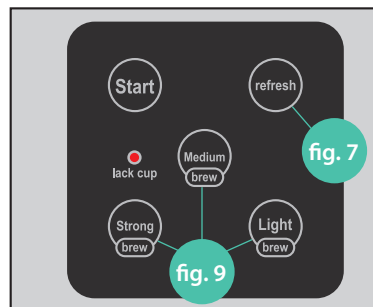
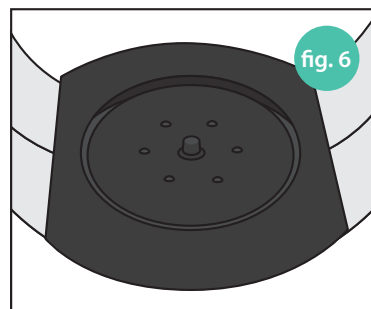
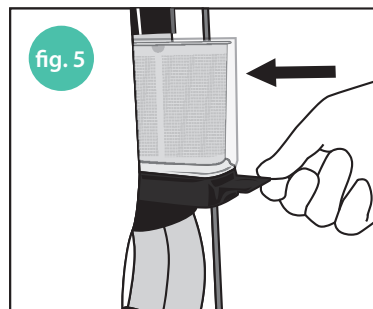
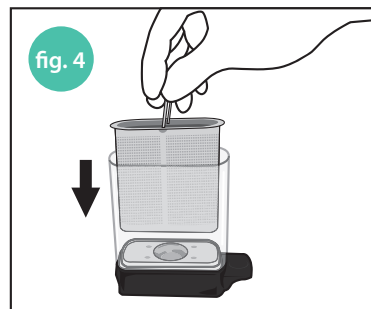
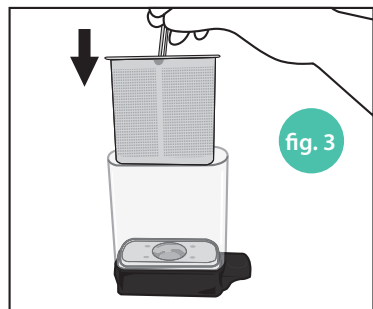
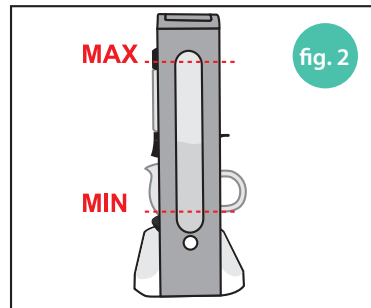
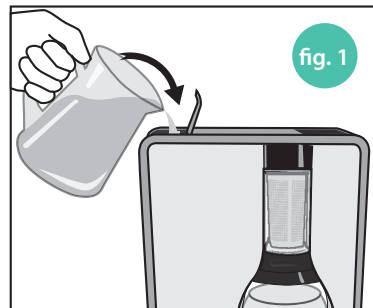

BREWING YOUR CUP OF TEA

1. Fill the Water Tank with filtered or clear water up to the MAX fill line indicator on the Tank (fig 1 & 2).
2. Place the desired amount of loose tea leaves in the Stainless Steel Strainer (fig 2).
3. Place the filled Stainless Steel Strainer inside the Glass Chamber (fig 3 & 4).
4. Firmly holding the Glass Chamber Lip, slide the Glass Chamber on its tracks into position in the Base until it “clicks” into place (fig 5).
5. Place the Glass Carafe onto the black Sensor Plate (fig 6). The Lack Cup indicator will no longer be red.
6. Press the Refresh button. The button will light blue and the Tea-Square will begin the cycle. When the Refresh process is complete, the Tea-Square will automatically stop. The blue Refresh button will turn off (fig. 7).
7. Remove the Glass Carafe and discard the water. The tea leaves in the Strainer and Glass Chamber are rinsed, hydrated and now ready for brewing. Replace the Glass Carafe (fig. 8).
8. Press the button that corresponds to your choice of strength: Light, Medium or Strong. The button will turn blue to indicate that the process has started (fig. 9).
9. When the brewing is done, the Tea-Square will automatically turn off and the button will no longer be blue. Remove the tea-filled glass carafe and serve.

Brewing Your Cup of Coffee

To brew fresh coffee, use 2 tablespoons coarse ground coffee and follow the same directions above for Light, Medium or Strong brewed coffee.

Specialty Blended Tea Recipes

With over 3,000 types of tea from which to choose, creating your own favorite tea blends can now be an on-going passion! Many specialty retailers and online stores offer top-quality teas to start your process. Use the recipes here as your template for measurements or simply add ingredients to fit your own preferences.

Energy

East Indian Lemon Black Tea (Serves 1)

- ¼ t. fresh lemon zest, finely grated
- 1 t. dried lemon peel
- 1 T. loose leaf black tea
- 1 t. honey or ground rock sugar
- 1 t. fresh lemon juice
- ¼ t. pure vanilla extract
- 1 thin slice lemon

Fill the Water Tank with clear or filtered water. Place the zest, peel and tea leaves in the Strainer and mix lightly with a spoon. Place the Strainer into the Glass Chamber and insert the filled Chamber into the Base until it clicks.

Press the Refresh button and run the cycle. Discard the water from the Glass Carafe, replace on the Sensor Plate and press the Strong button. When the cycle is done, add the honey, lemon juice, extract and stir lightly. Pour into a cup and garnish with lemon slice.

Stomach Sooth

Soothing Ginger Green Tea (Serves 1)

- 1 T. loose leaf green tea
- 1 thin slice ginger, peeled
- ½ mint leaf, torn in small pieces
- 1 t. honey or rock sugar
- Mint for garnish

Fill the Water Tank with clear or filtered water. Place the tea leaves, ginger and mint in the Strainer and mix lightly with a spoon. Place the Strainer into the Glass Chamber and insert the filled Chamber into the Base until it clicks.

(cont'd on next page)



Press the Refresh button and run the cycle. Discard the water from the Glass Carafe, replace on the Sensor Plate, and press the Medium button. When the cycle is done, fill one cup with tea and add a mint leaf, if desired.

Relax

Cinnamon & Spice Chai Tea (Serves 2)

- 2-3 T. loose leaf chai tea blend
- ½ t. ground cardamom
- 1 cinnamon stick, broken in pieces
- 2 peppercorns
- 2 t. honey or rock sugar
- 2 T. almond milk

Fill the Water Tank with clear or filtered water. Place the tea leaves, cardamom, cinnamon, and peppercorns in the Strainer and mix lightly with a spoon. Place the Strainer into the Glass Chamber and insert the filled Chamber into the Base until it clicks.

Press the Refresh button and run the cycle. Discard the water from the Glass Carafe, replace on the Sensor Plate, and press the Medium button. When the cycle is done, pour the tea into a cup and repeat the cycle to prepare another cup of tea (without changing the filled Strainer). When done, add the honey and almond milk equally to 2 cups tea. Serve while warm.

Antioxidant Boost

Strawberry Jade Tea (Serves 1–2)

- 3 T. loose leaf Jade tea
- ¼ c. dried strawberries
- 2 t. ground rock sugar
- 2 t. fresh orange juice
- 2 thin slices orange, peeled

Fill the Water Tank with clear or filtered water. Place the tea leaves and strawberries in the Strainer and mix lightly with a spoon. Place the Strainer into the Glass Chamber and insert the filled Chamber into the Base until it clicks.

Press the Refresh button and run the cycle. Discard the water from the Glass Carafe,

replace on the Sensor Plate, and press the Medium button. When the cycle is done, pour the tea into a cup and make another cup of tea (using the same filled Strainer). Divide the sugar equally among two cups of tea, add 1 teaspoon juice to each cup and float a slice of orange over each cup.

Cold & Flue Remedy

Spiced White Tea with Echinacea (Serves 1)

- 1-2 T. loose leaf white tea
- ½ t. ground cinnamon
- ½ t. ground cloves
- .75ml tincture echinacea
- 1 t. fresh orange juice
- 1 t. fresh lemon juice

Fill the Water Tank with clear or filtered water. Place the tea leaves, cinnamon and cloves in the Strainer and mix lightly with a spoon. Place the Strainer into the Glass Chamber and insert the filled Chamber into the Base until it clicks.

Press the Refresh button and run the cycle. Discard the water from the Glass Carafe, replace on the Sensor Plate, and press the Light button. When the cycle is done, pour tea into a warm cup. Add the echinacea and juices and stir lightly. Serve while warm.

Healthful Blended Teas (1 T. loose tea leaves + 1 teaspoon herb/spice)	To Assist
matcha tea + spearmint	Stimulate brain/wake-up
chamomile tea + kava	Sleep
white tea + orange peel + echinacea	Cold & flu symptoms
dandelion or parsley tea + nettle + ginger	Detox system
Peppermint tea + ginger + fennel	Motion sickness/nausea
Green tea + dried orange + cardamom	Energy
Ginseng tea + lavender	Relax; calm
Green tea + dried pineapple + matcha	Hydration

MAINTENANCE & SERVICE

1. **ALWAYS** allow the Tea-Square to cool completely before cleaning. Unplug the Tea-Square before cleaning. Empty the water from the Water Tank by removing the Drain Plug (fig. A) and draining water. Replace the Drain Plug when the water is fully emptied.
2. After each use, clean and dry the Tea-Square Base and all accessories. Use a damp cloth to clean the Base. **DO NOT** immerse the Base in water. Use non-abrasive soap only.
3. Do not place accessories in the dishwasher. Carefully wash in warm, sudsy water and dry thoroughly.

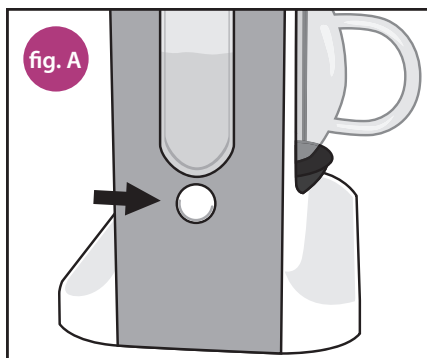

DECALCIFICATION

Over an extended period of time, the mineral deposits in the water will naturally accumulate. This can cause discoloration or an impediment to the brewing process. To avoid this, use filtered water for tea or decalcify the appliance once in a while as follows:

Fill the Water Tank with enough white vinegar to reach above the MIN Fill Line on the Water Tank. Do not fill the Strainer or glass Chamber with tea or other ingredients. Press the Strong button and run the brewing system. Discard the vinegar in the carafe. Drain and discard any vinegar remaining in the Water Tank.

Add enough water to the Water Tank to reach above the MIN Fill Line. Rinse the Strainer, glass Chamber and Carafe; dry and replace. Press the Strong button again and run the brewing system again. When done, empty the Carafe, clean and dry. Clean and dry the glass Chamber and Strainer. Drain any remaining water and refill with filtered or clean water. The Tea-Square is now ready to make tea again.

TROUBLESHOOTING

1. If the water does not pour according to the cycle, check the Water Tank and refill if needed. Check the Strainer and Glass Chamber area to determine if tea leaves have become stuck or are not allowing water to infuse throughout. Clean and replace the Strainer and Chamber.
2. The Tea-Square will make some slight noise as the water processes through the system. This is normal and part of the process.
3. If the Water Tank is low or empty, some slight noise may be heard. Refill the Tank promptly to avoid damage to the appliance.



WARRANTY & SERVICE

This Limited Warranty is for one full year from the date of purchase. It is applicable to the original purchaser only and is not transferable to a third party user. Repair or replacement of defective parts is solely at the seller's discretion. In the event that repair isn't possible, the seller will replace the product/part. If product repair/replacement won't suffice, the seller has the option of refunding the cash value of the product or component returned.

Product defects not covered under the Warranty provisions include normal wear and damage incurred from use or accidental negligence, misuse of instruction specifications or repair by unauthorized parties. The manufacturing company is not liable for any incidental or consequential damages incurred by such circumstances.

For Customer Service or Questions, Please call: 888-552-0033

Gourmia

www.gourmia.com



Gourmia

www.gourmia.com