

Kinetix 350 Single-axis EtherNet/IP Servo Drives

Catalog Numbers 2097-V31PR0-LM, 2097-V31PR2-LM,
2097-V32PR0-LM, 2097-V32PR2-LM, 2097-V32PR4-LM,
2097-V33PR1-LM, 2097-V33PR3-LM, 2097-V33PR5-LM, 2097-V33PR6-LM,
2097-V34PR3-LM, 2097-V34PR5-LM, 2097-V34PR6-LM

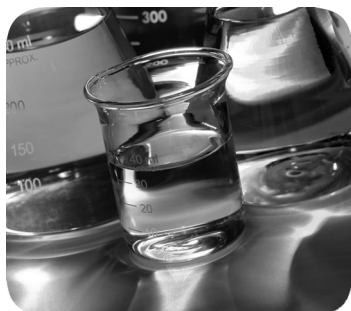

Important User Information

Read this document and the documents listed in the additional resources section about installation, configuration, and operation of this equipment before you install, configure, operate, or maintain this product. Users are required to familiarize themselves with installation and wiring instructions in addition to requirements of all applicable codes, laws, and standards.

Activities including installation, adjustments, putting into service, use, assembly, disassembly, and maintenance are required to be carried out by suitably trained personnel in accordance with applicable code of practice.

If this equipment is used in a manner not specified by the manufacturer, the protection provided by the equipment may be impaired.

In no event will Rockwell Automation, Inc. be responsible or liable for indirect or consequential damages resulting from the use or application of this equipment.

The examples and diagrams in this manual are included solely for illustrative purposes. Because of the many variables and requirements associated with any particular installation, Rockwell Automation, Inc. cannot assume responsibility or liability for actual use based on the examples and diagrams.

No patent liability is assumed by Rockwell Automation, Inc. with respect to use of information, circuits, equipment, or software described in this manual.

Reproduction of the contents of this manual, in whole or in part, without written permission of Rockwell Automation, Inc., is prohibited.

Throughout this manual, when necessary, we use notes to make you aware of safety considerations.



WARNING: Identifies information about practices or circumstances that can cause an explosion in a hazardous environment, which may lead to personal injury or death, property damage, or economic loss.



ATTENTION: Identifies information about practices or circumstances that can lead to personal injury or death, property damage, or economic loss. Attentions help you identify a hazard, avoid a hazard, and recognize the consequence.

IMPORTANT

Identifies information that is critical for successful application and understanding of the product.

Labels may also be on or inside the equipment to provide specific precautions.



SHOCK HAZARD: Labels may be on or inside the equipment, for example, a drive or motor, to alert people that dangerous voltage may be present.



BURN HAZARD: Labels may be on or inside the equipment, for example, a drive or motor, to alert people that surfaces may reach dangerous temperatures.



ARC FLASH HAZARD: Labels may be on or inside the equipment, for example, a motor control center, to alert people to potential Arc Flash. Arc Flash will cause severe injury or death. Wear proper Personal Protective Equipment (PPE). Follow ALL Regulatory requirements for safe work practices and for Personal Protective Equipment (PPE).

This manual contains new and updated information as indicated in the following table.

Topic	Page
Add a reference to the Motion System Tuning Application Techniques, publication MOTION-AT005	9
Added a footnote to Figure 1 - Typical Kinetix 350 Drive Installation	13
Added the 2198-ABQE Encoder Output module to typical communication configurations.	14
Updated Input Power Circuit-protection Specifications table	19
Corrected the description of REG digital input signal	39
Add an MOV (199-MSMD1) as an option to Brake Wiring Schematic	43
Added a reference to Appendix C	52
Changed the IMPORTANT statement to an ATTENTION statement and added a reference to Appendix C	53
Changed footnote to include an equivalent diode	67
Modified Important statement Ethernet Cable Connections section	74
Added footnote to Figure 44 - Ethernet Wiring Example - External Switch	75
Added descriptions for status indicators StAt, Ht, buS, Curr	78
Added an Attention statement	86
Added a link Motion System Tuning Application Techniques, publication MOTION-AT005	94
Corrected the Attention statement under Troubleshooting the Safe Torque-off Function	103
Updated Figure 49 -Single-axis Relay Configuration (Stop Category 0) with Automatic Reset	108
Added Figure 50 - Single-axis Relay Configuration (Stop Category 0) with Manual Reset	109
Added Safety Input and Output Schematics	110
Duplicated the Important statement that describes the fault detection ability of TTL encoders	124
Added Appendix C - Leakage Currents	151

Notes:

	Preface	
	Conventions	9
	Additional Resources	9
	Chapter 1	
Start	About the Kinetix 350 Drive System	12
	Catalog Number Explanation	15
	Agency Compliance	16
	CE Requirements	16
	Chapter 2	
Install the Kinetix 350 Drive System	System Design Guidelines	17
	System Mounting Requirements	17
	Circuit Breaker/Fuse Selection	18
	Contactor Ratings	20
	Transformer Selection	20
	Transformer Specifications for Input Power	21
	Enclosure Selection	21
	Power Dissipation Specifications	22
	Minimum Clearance Requirements	23
	Electrical Noise Reduction	24
	Bonding Drives	24
	Bonding Multiple Subpanels	26
	Establish Noise Zones	27
	Cable Categories for Kinetix 350 Drive Components	29
	Noise Reduction Guidelines for Drive Accessories	29
	Mount Your Kinetix 350 Drive	32
	Chapter 3	
Kinetix 350 Drive Connector Data	Kinetix 350 Drive Connectors and Indicators	34
	Safe Torque-off Connector Pinout	35
	I/O Connector Pinout	36
	Motor Feedback (MF) Connector Pinout	37
	Ethernet Communication Connector Pinout	37
	AC Input Power Connector Pinout	38
	Back-up Power Connector Pinout	38
	Shunt Resistor and DC Bus Connector Pinout	38
	Motor Power Connector Pinout	38
	Control Signal Specifications	39
	Digital Inputs	39
	Motor Brake Output	42
	Ethernet Communication Specifications	43
	24V DC Back-up Power Specifications	43
	Motor Feedback Specifications	44

Feedback Power Supply 49

Connect the Kinetix 350 Drive System

Chapter 4

Basic Wiring Requirements 51
 Recommended Cables 52
 Route Power and Signal Wiring..... 52
 Determine the Input Power Configuration..... 52
 Three-phase Power Wired to Three-phase Drives 53
 Single-phase Power Wired to Single-phase Drives 54
 Voltage Doubler Operation 54
 Isolation Transformer in Grounded Power Configurations ... 55
 Three-phase Power Wired to Single-phase Drives 55
 Voiding of CE Compliance..... 57
 Grounding Your Kinetix 350 Drive System..... 58
 Ground Your Drive to the System Subpanel 58
 Ground Multiple Subpanels..... 59
 Power Wiring Requirements 60
 Wiring Guidelines..... 61
 Wiring the Kinetix 350 Drive Connectors..... 62
 Wire the Safe Torque-off (STO) Connector..... 62
 Wire the Back-up Power (BP) Connector 62
 Wire the Input Power (IPD) Connector..... 63
 Wire the Motor Power (MP) Connector 64
 Apply the Motor Cable Shield Clamp..... 69
 Feedback and I/O Cable Connections 70
 Flying-lead Feedback Cable Pin-outs 71
 Wiring the Feedback and I/O Connectors 72
 Wire the I/O Connector..... 72
 Wire the Low-profile Connector Kit..... 73
 Shunt Resistor Connections..... 74
 Ethernet Cable Connections 74

Configure and Start up the Kinetix 350 Drive System

Chapter 5

Keypad Input 78
 Status Indicators..... 79
 Configure the Kinetix 350 Drive Ethernet IP Address..... 81
 Ethernet Connection 81
 Kinetix 350 Drive Ethernet Port Configuration..... 81
 Obtain the Kinetix 350 Drives' Current Ethernet Settings 81
 Configure the IP Address Manually (Static Address) 82
 Configure the IP Address Automatically (Dynamic Address).. 83
 Configure the Logix5000 EtherNet/IP Controller 84
 Configure the Logix5000 Controller 84
 Configure the Kinetix 350 Drive..... 86
 Configure the Motion Group..... 89
 Configure Axis Properties 90

	Download the Program	93
	Apply Power to the Kinetix 350 Drive	93
	Test and Tune the Axes.....	94
	Test the Axes.....	94
	Tune the Axes.....	97
	Disable EnableInputChecking by Using a Logix Designer Message Instruction	100
	Chapter 6	
Kinetix 350 Drive Safe Torque-off Feature	Certification	101
	Important Safety Considerations	101
	Safety Category 3 Requirements	102
	Stop Category Definition	102
	Performance Level and Safety Integrity Level (SIL) CL2	102
	Description of Operation	102
	Troubleshoot the Safe Torque-off Function	103
	PFD and PFH Definitions	103
	PFD and PFH Data	103
	Safe Torque-off Connector Data	104
	STO Connector Pinouts	104
	Wiring Your Safe Torque-off Circuit	105
	European Union Directives	105
	Safe Torque-off Wiring Requirements.....	106
	Kinetix 350 Drive Safe Torque-off Feature	107
	Safe Torque-off Feature Bypass	107
	Kinetix 350 Drive Safe Torque-off Wiring Diagrams	108
	Safe Torque-off Signal Specifications.....	109
	Safety Input and Output Schematics.....	110
	Chapter 7	
Troubleshoot the Kinetix 350 Drive	Safety Precautions	111
	Interpret Status Indicators	112
	Four-digit Display Messages	112
	Error Codes.....	113
	Fault Codes	113
	Status Indicators.....	119
	General System Behavior.....	120
	Logix5000 Controller and Drive Behavior.....	124
	Kinetix 350 Drive Exception Behavior	124
	Web Server Interface	128
	Appendix A	
Interconnect Diagrams	Interconnect Diagram Notes	130
	Power Wiring Examples	131
	Shunt Resistor Wiring Example.....	133
	Kinetix 350 Drive/Rotary Motor Wiring Examples	134

	Kinetix 350 Drive/Actuator Wiring Examples.....	137
	Motor Brake Currents.....	140
	System Block Diagrams.....	141
	Appendix B	
Upgrade the Kinetix 350 Drive Firmware	Before You Begin.....	143
	Configure Logix5000 Communication.....	144
	Upgrade Firmware.....	145
	Verify the Firmware Upgrade.....	149
	Appendix C	
Leakage Current Specifications	151
	Index	155

This manual provides detailed installation instructions for mounting, wiring, and troubleshooting your Kinetix® 350 drive; and system integration for your drive/motor combination with a Logix5000™ controller.

Conventions

These conventions are used throughout this manual:

- Bulleted lists such as this one provide information, not procedural steps.
- Numbered lists provide steps or hierarchical information.

Additional Resources

These documents contain additional information concerning related products from Rockwell Automation.

Table 1 - Additional Resources

Resource	Description
Kinetix Servo Drives Specifications Technical Data, publication KNX-TD003	Specifications for Kinetix servo drive motion control products.
Kinetix 350 Single-axis EtherNet/IP Servo Drive Installation Instructions, publication 2097-IN008	Information to help you install your Kinetix 350 drive system.
Kinetix 300 Shunt Resistor Installation Instructions, publication 2097-IN002	Information to help you install and wire the Kinetix 300 shunt resistors.
Kinetix 300 AC Line Filter Installation Instructions, publication 2097-IN003	Information to help you install and wire the Kinetix 300 AC line filter.
Kinetix 300 I/O Terminal Expansion Block Installation Instructions, publication 2097-IN005	Information to help you install and wire the Kinetix 300 I/O terminal expansion block.
Encoder Output Emulator Module Installation Instructions, publication 2198-IN01	Information to help you install and wire Encoder Output Emulator Module.
CompactLogix L3ER Controllers User Manual, publication 1769-UM021	Information to help you install, configure, program, and operate a CompactLogix™ system.
Stratix 2000 Ethernet Unmanaged Switches Installation Instructions, publication 1783-IN001	Information to help you install and operate a Stratix 2000 Ethernet Switches.
Ethernet/IP Benefits of Industrial Connectivity in Industrial Apps White Paper, publication 1585-WP001A	Provides general guidelines and theory for Ethernet/IP industrial systems.
Industrial Ethernet Media, publication 1585-BR001	This brochure provides connectivity solutions for Ethernet networks and integrated architecture.
Guidance for Selecting Cables for EtherNet/IP Networks White Paper, publication ENET-WP007	This guide is arranged to help you select cables that are based on your application, environmental conditions, and mechanical requirements
Integrated Motion on SERCOS and EtherNet/IP Systems - Analysis and Comparison White Paper, publication MOTION-WP007	This white paper compares and contrasts SERCOS and EtherNet/IP networks with a ControlLogix® controller.
Industrial Automation Wiring and Grounding Guidelines, publication 1770-4.1	Provides general guidelines for installing a Rockwell Automation industrial system.
System Design for Control of Electrical Noise Reference Manual, publication GMC-RM001	Information, examples, and techniques that are designed to minimize system electrical noise failures.
Kinetix Motion Control Selection Guide, publication KNX-SG001	Specifications, motor/servo-drive system combinations, and accessories for Kinetix motion control products.
Motion Analyzer software, download at http://ab.rockwellautomation.com/Motion-Control/Motion-Analyzer-Software	This program helps you choose drive and motor size by using application analysis software.
ControlLogix Controllers User Manual, publication 1756-UM001	Information to help you install, configure, program, and operate a ControlLogix system.
Integrated Motion on the EtherNet/IP Network: Configuration and Startup User Manual, publication MOTION-UM003	Information to help you configure and troubleshoot your ControlLogix and CompactLogix EtherNet/IP network modules.
Motion System Tuning Application Techniques, publication MOTION-ATO05	Information on tuning a Kinetix drive system.

Table 1 - Additional Resources (Continued)

Resource	Description
842E-CM Integrated Motion Encoder on EtherNet/IP User Manual. Publication 842E-UM002A	Information to help you install, wire, and troubleshoot an integrated motion encoder on EtherNet/IP network.
ControlFLASH Firmware Upgrade Kit User Manual, publication 1756-UM105	For ControlFLASH™ information not specific to any drive family.
Rockwell Automation Configuration and Selection Tools, website http://www.rockwellautomation.com/global/support/selection.page	Online product selection and system configuration tools, including AutoCAD (DXF) drawings.
Rockwell Automation Product Certification, website http://www.rockwellautomation.com/global/certification/overview.page	For declarations of conformity (DoC) currently available from Rockwell Automation.
Rockwell Automation Industrial Automation Glossary, publication AG-7.1	A glossary of industrial automation terms and abbreviations.

You can view or download publications at <http://www.rockwellautomation.com/global/literature-library/overview.page>. To order paper copies of technical documentation, contact your local Allen-Bradley distributor or Rockwell Automation sales representative.

Start

Topic	Page
About the Kinetix 350 Drive System	12
Catalog Number Explanation	15
Agency Compliance	16

About the Kinetix 350 Drive System

The Kinetix® 350 single-axis EtherNet/IP servo drive is designed to provide a solution for applications with output power requirements between 0.4...3.0 kW (2...12 A rms).

Table 2 - Kinetix 350 Drive System Overview

Kinetix 350 System Component	Cat. No.	Description
Kinetix 350 Integrated Motion on EtherNet/IP Servo Drive	2097-V3xPRx-LM	Kinetix 350 integrated motion on EtherNet/IP drives with safe torque-off feature are available with 120/240V or 480V AC input power.
AC Line Filters	2090 2097-Fx	Bulletin 2090 and Bulletin 2097-Fx AC line filters are required to meet CE with Kinetix 350 drives without an integrated line filter. Bulletin 2097 filters are available in foot mount and side mount.
Shunt Module	2097-Rx	Bulletin 2097 shunt resistors connect to the drive and provides shunt capability in regenerative applications.
Terminal block for I/O connector	2097-TB1	50-pin terminal block. Use with IOD connector for control interface connections.
Stratix® 2000 Ethernet Switch	1783-US05T	An Ethernet switch divides an Ethernet network into segments and directs network traffic efficiently.
Logix PAC® Controller Platforms	Bulletin 5069 Bulletin 1768 and 1769	EtherNet/IP networking with CompactLogix™ 5370 and CompactLogix 5380 controllers with embedded dual-port. 1769-L3x controllers with embedded single port. 1768-L4x controller and 1768-L4xS safety controller with 1768-ENBT EtherNet/IP communication module.
	1756-EN2T, 1756-EN2TR, and 1756-EN3TR module	EtherNet/IP network communication modules for use with ControlLogix® 5570 and ControlLogix 5580 controllers.
Studio 5000® Environment or RSLogix 5000® Software	—	RSLogix 5000 software (version 20 or earlier) and the Studio 5000 Logix Designer® application (version 21 or later) are used to program, commission, and maintain the Logix family of controllers.
Encoder Output Module	2198-ABQE	The Allen-Bradley encoder output module is a DIN-rail mounted EtherNet/IP network-based standalone module capable of outputting encoder pulses to a customer-supplied peripheral device (cameras, for example, used in line-scan vision systems).
Rotary Servo Motors	MP-Series, TL-Series	Compatible rotary motors include the MP-Series™ (Bulletin MPL, MPM, MPF, and MPS) and TL-Series™ (Bulletin TLY) motors.
Linear Stages	MP-Series (BallScrew)	Compatible stages include MP-Series (Bulletin MPAS) Integrated Linear Stages.
Electric Cylinders	MP-Series, TL-Series	Compatible electric cylinders include MP-Series and TL- Series (Bulletin MPAI, TLAR, and MPAL) Electric Cylinders.
Encoder	842E-CM	Integrated Motion Encoder on EtherNet/IP network.
Cables	Motor/brake and feedback cables	Motor power/brake and feedback cables include SpeedTec and threaded DIN connectors at the motor. Power/brake cables have flying leads on the drive end and straight connectors that connect to servo motors. Feedback cables have flying leads that wire to low-profile connector kits on the drive end and straight connectors on the motor end.
	Communication cables	1585J-M8CJBM-x (shielded) or 1585J-M8UBJBM-x (high-flex shielded) Ethernet cable.

Figure 1 - Typical Kinetix 350 Drive Installation

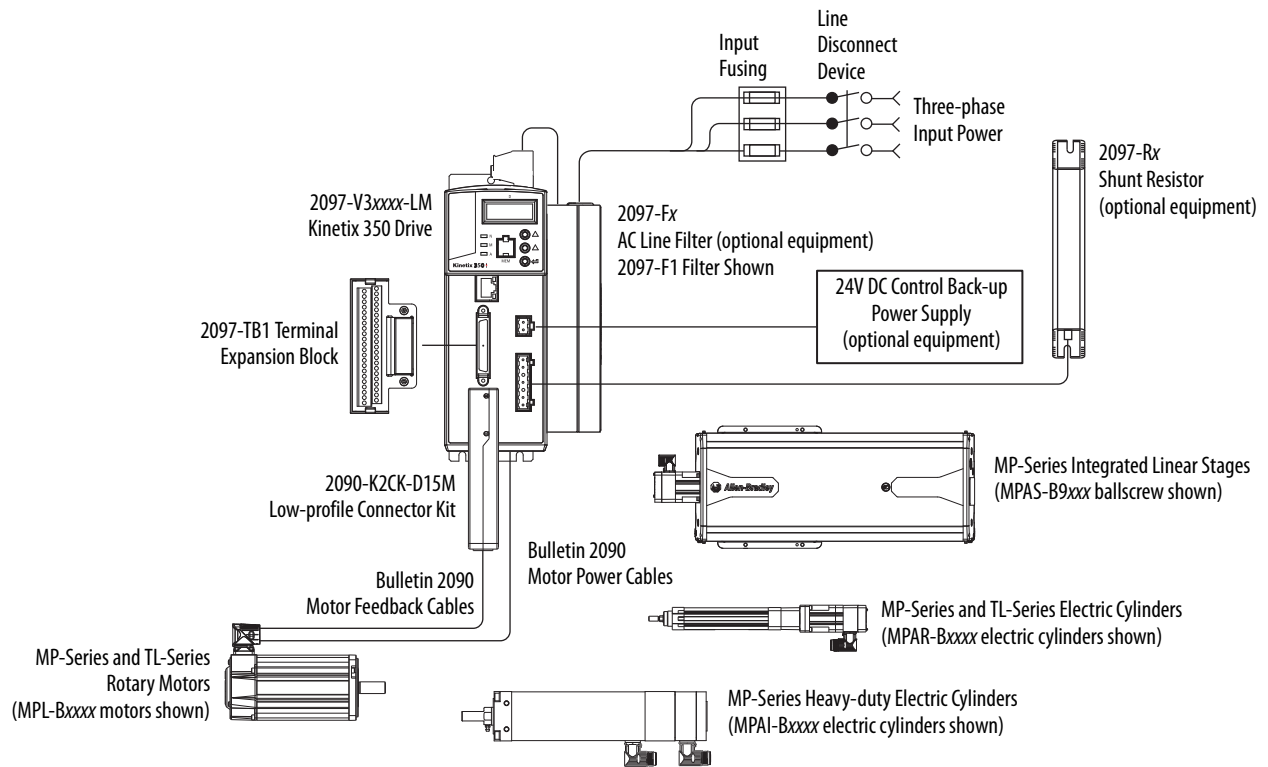

(1) See [Ethernet Cable Connections on page 74](#) for information on how to use an unmanaged switch in your application.

Figure 2 - Typical K350 Communication Configuration

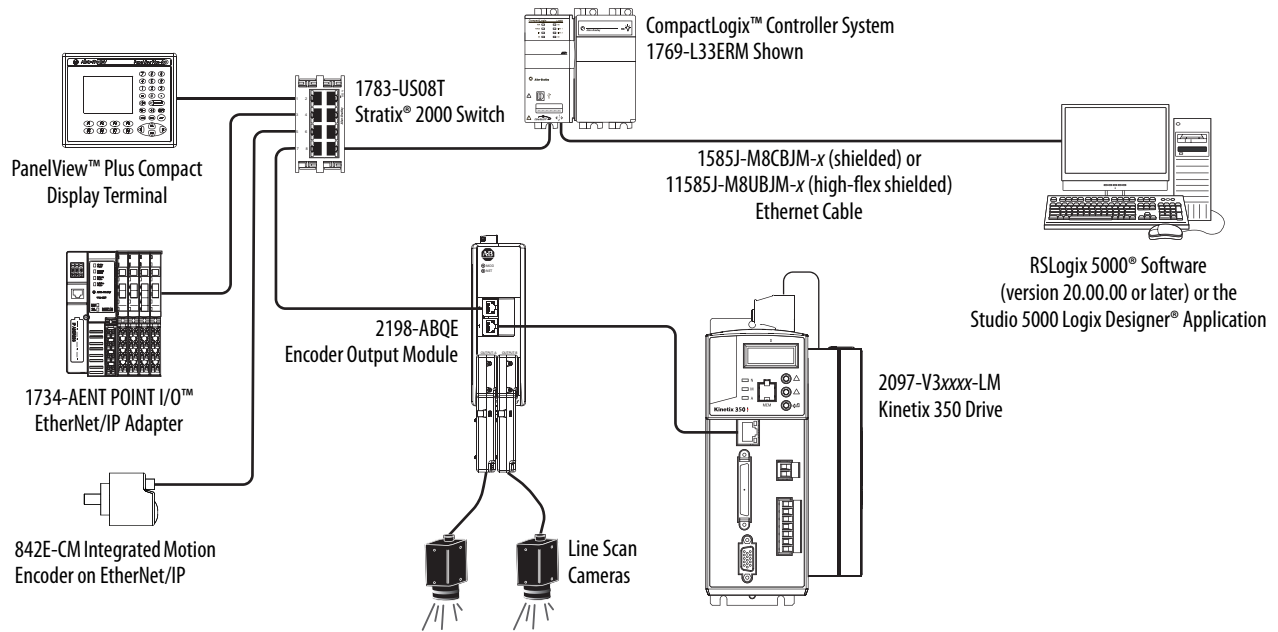

See Encoder Output Module Installation Instructions, publication [2198-UM003](#). For information to help you install and wire the 2198-ABQE Encoder Output Module.

Catalog Number Explanation

Kinetix 350 drive catalog numbers and descriptions are listed in these tables.

Table 3 - Kinetix 350 Drives (single-phase)

Cat. No.	Input Voltage	Continuous Output Current A (0-pk)	Features
2097-V31PR0-LM	120V, 1 Ø 240V, 1 Ø	2.8	<ul style="list-style-type: none"> 120V Doubler mode Safe Torque-off
2097-V31PR2-LM		5.7	
2097-V32PR0-LM	240V, 1 Ø	2.8	<ul style="list-style-type: none"> Integrated AC line filter Safe Torque-off
2097-V32PR2-LM		5.7	
2097-V32PR4-LM		11.3	

Table 4 - Kinetix 350 Drives (single/three-phase)

Cat. No.	Input Voltage	Continuous Output Current A (0-pk)	Features
2097-V33PR1-LM	120V, 1 Ø 240V, 1 Ø 240V, 3 Ø	2.8	Safe Torque-off
2097-V33PR3-LM		5.7	
2097-V33PR5-LM		11.3	
2097-V33PR6-LM		17.0	

Table 5 - Kinetix 350 Drives (three-phase)

Cat. No.	Input Voltage	Continuous Output Current A (0-pk)	Features
2097-V34PR3-LM	480V, 3 Ø	2.8	Safe Torque-off
2097-V34PR5-LM		5.7	
2097-V34PR6-LM		8.5	

Table 6 - Kinetix 350 Drive Accessories

Cat. No.	Drive Components
2097-Fx	AC line filters
2097-TB1	Terminal block for I/O connector
2097-Rx	Shunt resistors
2097-PGMR	Memory module programmer
2097-MEM	Memory modules 12 pack

Agency Compliance

If this product is installed within the European Union and has the CE marking, the following regulations apply.



ATTENTION: Meeting CE requires a grounded system. The method of grounding the AC line filter and drive must match. Failure to do this renders the filter ineffective and can cause damage to the filter. For grounding examples, see [Grounding Your Kinetix 350 Drive System on page 58](#).

For more information on electrical noise reduction, see the System Design for Control of Electrical Noise Reference Manual, publication [GMC-RM001](#).

CE Requirements

To meet CE requirements, these requirements apply:

- Install an AC line filter (Bulletin 2090 or 2097) as close to the drive as possible.
- Use 2090 series motor power cables or use connector kits and terminate the cable shields to the subpanel with clamp provided.
- Use 2090 series motor feedback cables or use connector kits and properly terminate the feedback cable shield. Drive-to-motor power and feedback cables must not exceed 20 m (65.6 ft).
- Install the Kinetix 350 system inside an enclosure. Run input power wiring in conduit (grounded to the enclosure) outside of the enclosure. Separate signal and power cables.
- Segregate input power wiring and motor power cables from control wiring and motor feedback cables. Use shielded cable for power wiring and provide a grounded 360° clamp termination.

See Appendix A on [page 129](#) for interconnect diagrams, including input power wiring and drive/motor interconnect diagrams.

Install the Kinetix 350 Drive System

Topic	Page
System Design Guidelines	17
Electrical Noise Reduction	24
Mount Your Kinetix 350 Drive	32



ATTENTION: Plan the installation of your system so that you can cut, drill, tap, and weld with the system that is removed from the enclosure. Because the system is of the open type construction, be careful to keep any metal debris from falling into it. Metal debris or other foreign matter can become lodged in the circuitry, which can result in damage to components.

System Design Guidelines

Use the information in this section when designing your enclosure and planning to mount your system components on the panel.

For on-line product selection and system configuration tools, including AutoCAD (DXF) drawings of the product, refer to <http://www.rockwellautomation.com/global/support/selection.page>

System Mounting Requirements

- To comply with UL and CE requirements, the Kinetix® 350 system must be enclosed in a grounded conductive enclosure. It must that offer protection as defined in standard EN 60529 (IEC 529) to IP4X such that they are not accessible to an operator or unskilled person. A NEMA 4X enclosure exceeds these requirements providing protection to IP66.
- The panel that you install inside the enclosure for mounting your system components must be on a flat, rigid, vertical surface that won't be subjected to shock, vibration, moisture, oil mist, dust, or corrosive vapors.
- Size the drive enclosure so as not to exceed the maximum ambient temperature rating. Consider heat dissipation specifications for all drive components.
- Segregate input power wiring and motor power cables from control wiring and motor feedback cables. Use shielded cable for power wiring and provide a grounded 360° clamp termination.

- Use high-frequency (HF) bonding techniques to connect the enclosure, machine frame, and motor housing, and to provide a low-impedance return path for high-frequency (HF) energy and reduce electrical noise.
- Use 2090 series motor feedback cables or use connector kits and properly terminate the feedback cable shield. Drive-to-motor power and feedback cables must not exceed 20 m (65.6 ft).

IMPORTANT System performance was tested at these cable length specifications. These limitations are also a CE requirement.

See the System Design for Control of Electrical Noise Reference Manual, publication [GMC-RM001](#), to understand the concept of electrical noise reduction better.

Circuit Breaker/Fuse Selection

The Kinetix 350 drives use internal solid-state motor short-circuit protection and, when protected by suitable branch circuit protection, are rated for use on a circuit capable of delivering up to 100,000 A (fuses) and 65,000 A (circuit breakers).

IMPORTANT Do not use circuit protection devices on the output of an AC drive as an isolating disconnect switch or motor overload device. These devices are designed to operate on sine wave voltage and the drive's PWM waveform does not allow it to operate properly. As a result, damage to the device occurs.

Make sure the selected components are properly coordinated and meet acceptable codes including any requirements for branch circuit protection. Evaluation of the short-circuit available current is critical and must be kept below the short-circuit current rating of the circuit breaker.

See the Kinetix Servo Drives Specifications Technical Data, publication [KNX-TD003](#) for input current and inrush current specifications for your Kinetix 350 drive.

See [Fuse and Circuit Breaker \(CB\) Specifications](#) on [page 19](#) for recommended circuit breakers and fuses.

Table 7 - Fuse and Circuit Breaker (CB) Specifications

Drive Cat. No.	Drive Voltage	Phase	UL Applications			IEC (non-UL) Applications		
			Fuses (Bussmann) Cat. No.	Miniature CB ⁽¹⁾ Cat. No.	Motor Protection CB, ⁽¹⁾ ⁽²⁾ Self-protected CMC Cat. No.	Miniature CB ⁽¹⁾ Cat. No.		Motor Protection CB ⁽¹⁾ Cat. No.
2097-V31PR0-LM	120V	Single-phase (voltage doubler)	KTK-R-20 (20 A)	1489-M1C200	140M-D8E-C20	1489-M1C200	1492-SPM1D200	140M-D8E-C20
	120/240V	Single-phase	KTK-R-10 (10 A)	1489-M1C100	140M-C2E-C10	1489-M1C100	1492-SPM1D100	140M-C2E-C10
2097-V31PR2-LM	120V	Single-phase (voltage doubler)	KTK-R-30 (30 A)	1489-M1C300	140M-F8E-C32	1489-M1C300	1492-SPM1D300	140M-F8E-C32
	120/240V	Single-phase	KTK-R-20 (20 A)	1489-M1C200	140M-D8E-C20	1489-M1C200	1492-SPM1D200	140M-D8E-C20
2097-V32PR0-LM	240V	Single-phase	KTK-R-20 (20 A)	1489-M1C150	140M-D8E-C16	1489-M1C150	1492-SPM1D150	140M-D8E-C16
2097-V32PR2-LM			KTK-R-20 (20 A)	1489-M1C200	140M-D8E-C20	1489-M1C200	1492-SPM1D200	140M-D8E-C20
2097-V32PR4-LM			KTK-R-30 (30 A)	1489-M1C300	140M-F8E-C32	1489-M1C300	1492-SPM1D320	140M-F8E-C32
2097-V33PR1-LM	120/240V	Single-phase	KTK-R-20 (20 A)	1489-M1C200	140M-D8E-C20	1489-M1C200	1492-SPM1D200	140M-D8E-C20
	240V	Three-phase	KTK-R-15 (15 A)	1489-M3C150	140M-D8E-C16	1489-M3C150	1492-SPM3D150	140M-D8E-C16
2097-V33PR3-LM	120/240V	Single-phase	KTK-R-20 (20 A)	1489-M1C200	140M-D8E-C20	1489-M1C200	1492-SPM1D200	140M-D8E-C20
	240V	Three-phase	KTK-R-15 (15 A)	1489-M3C150	140M-D8E-C16	1489-M3C150	1492-SPM3D150	140M-D8E-C16
2097-V33PR5-LM	120/240V	Single-phase	KTK-R-30 (30 A)	1489-M1C300	140M-F8E-C32	1489-M1C300	1492-SPM1D300	140M-F8E-C32
	240V	Three-phase	KTK-R-20 (20 A)	1489-M3C200	140M-D8E-C20	1489-M3C200	1492-SPM3D200	140M-D8E-C20
2097-V33PR6-LM	120/240V	Single-phase	LPJ-40SP (40 A) Class J	N/A	140M-F8E-C32	N/A	N/A	140M-F8E-C32
	240V	Three-phase	KTK-R-30 (30 A)	1489-M3C300		1489-M3C300	1492-SPM3D300	
2097-V34PR3-LM	480V	Three-phase	KTK-R-10 (10 A)	1489-M3C100	140M-C2E-C10	1489-M3C100	1492-SPM3D100	140M-C2E-C10
2097-V34PR5-LM			KTK-R-10 (10 A)	1489-M3C100	140M-C2E-C10	1489-M3C100	1492-SPM3D100	140M-C2E-C10
2097-V34PR6-LM			KTK-R-20 (20 A)	1489-M3C200	140M-D8E-C20	1489-M3C200	1492-SPM3D200	140M-D8E-C20

(1) Bulletin 1492 and 1489 circuit protection devices have lower short-circuit current ratings than Bulletin 140M devices.

See <http://ab.rockwellautomation.com/allenbradley/productdirectory.page?> for product literature with specific short-circuit ratings.

(2) For UL applications, Bulletin 140M devices are applied as self-protected combination motor controllers.

Contactor Ratings

Table 8 - Kinetix 350 Drives (120/240V)

Cat. No.	Drive Voltage	AC Coil Contactor	DC Coil Contactor
2097-V31PR0-LM	120V	100-C23x10	100-C23Zx10
	240V	100-C12x10	100-C12Zx10
2097-V31PR2-LM	120V	100-C30x10	100-C30Zx10
	240V	100-C23x10	100-C23Zx10

Table 9 - Kinetix 350 Drives (240V)

Cat. No.	Drive Voltage	AC Coil Contactor	DC Coil Contactor
2097-V32PR0-LM	240V	100-C23x10	100-C23Zx10
2097-V32PR2-LM	240V	100-C23x10	100-C23Zx10
2097-V32PR4-LM	240V	100-C30x10	100-C30Zx10
2097-V33PR1-LM	120V	100-C23x10	100-C23Zx10
	240V	100-C16x10	100-C16Zx10
2097-V33PR3-LM	120V	100-C23x10	100-C23Zx10
	240V	100-C16x10	100-C16Zx10
2097-V33PR5-LM	120V	100-C30x10	100-C30Zx10
	240V	100-C23x10	100-C23Zx10
2097-V33PR6-LM	120V	N/A	N/A
	240V	100-C30x10	100-C30Zx10

Table 10 - Kinetix 350 Drives (480V)

Cat. No.	Drive Voltage	AC Coil Contactor	DC Coil Contactor
2097-V34PR3-LM	480V	100-C12x10	100-C12Zx10
2097-V34PR5-LM		100-C12x10	100-C12Zx10
2097-V34PR6-LM		100-C23x10	100-C23Zx10

Transformer Selection

The Kinetix 350 drive does not require an isolation transformer for three-phase input power. However, a transformer can be required to match the voltage requirements of the controller to the available service.

To choose the size of a transformer for the main AC power inputs, refer to [page 18](#) and [Transformer Specifications for Input Power](#) on [page 21](#).

IMPORTANT If you are using an autotransformer, make sure that the phase to neutral/ground voltages do not exceed the input voltage ratings of the drive.

IMPORTANT Use a form factor of 1.5 for single and three-phase power (where form factor is used to compensate for transformer, drive, and motor losses, and to account for utilization in the intermittent operating area of the torque speed curve).

For example, to choose the size of a transformer for the voltage requirements of catalog number

2097-V34PR6-LM = 3 kW continuous x 1.5 = 4.5 KVA transformer.

Transformer Specifications for Input Power

Attribute	Value (460V system)
Input volt-amperes	750VA
Input voltage	480V AC
Output voltage	120...240V AC

Enclosure Selection

This example is provided to assist you in choosing the size of the enclosure for your Bulletin 2097 drive system. You need heat dissipation data from all components that are planned for your enclosure to calculate the enclosure size. See Power Dissipation Specifications on [page 22](#) for your drive.

With no active method of heat dissipation (such as fans or air conditioning), either of the following approximate equations can be used.

Metric	Standard English
$A = \frac{0.38Q}{1.8T - 1.1}$	$A = \frac{4.08Q}{T - 1.1}$
Where T is temperature difference between inside air and outside ambient (°C), Q is heat that is generated in enclosure (Watts), and A is enclosure surface area (m ²). The exterior surface of all six sides of an enclosure is calculated as	Where T is temperature difference between inside air and outside ambient (°F), Q is heat that is generated in enclosure (Watts), and A is enclosure surface area (ft ²). The exterior surface of all six sides of an enclosure is calculated as
$A = 2dw + 2dh + 2wh$	$A = (2dw + 2dh + 2wh) / 144$
Where d (depth), w (width), and h (height) are in meters.	Where d (depth), w (width), and h (height) are in inches.

If the maximum ambient rating of the Kinetix 350 drive system is 40 °C (104 °F) and if the maximum environmental temperature is 20 °C (68 °F), then T=20. In this example, the total heat dissipation is 416 W (sum of all components in enclosure). So, in the equation below, T=20 and Q=416.

$$A = \frac{0.38 (416)}{1.8 (20) - 1.1} = 4.53 \text{ m}^2$$

In this example, the enclosure must have an exterior surface of at least 4.53 m². If any portion of the enclosure is not able to transfer heat, exclude heat in the calculation.

Because the minimum cabinet depth to house the Kinetix 350 system (selected for this example) is 332 mm (13 in.), the cabinet must be approximately 2000 x 700 x 332 mm (78.7 x 27.6 x 13.0 in.) HxWxD.

$$2 \times (0.332 \times 0.70) + 2 \times (0.332 \times 2.0) + 2 \times (0.70 \times 2.0) = 4.59 \text{ m}^2$$

Because this cabinet size is considerably larger than what is necessary to house the system components, it can be more efficient to provide a means of cooling in a smaller cabinet. Contact your cabinet manufacturer for options available to cool your cabinet.

Power Dissipation Specifications

This table shows the maximum power dissipation of each drive. Use this table to size an enclosure and calculate required ventilation for your Kinetix 350 drive system.

Cat. No.	Power Dissipation, W
2097-V31PR0-LM	28
2097-V31PR2-LM	39
2097-V32PR0-LM	28
2097-V32PR2-LM	39
2097-V32PR4-LM	67
2097-V33PR1-LM	28
2097-V33PR3-LM	39
2097-V33PR5-LM	67
2097-V33PR6-LM	117
2097-V34PR3-LM	39
2097-V34PR5-LM	58
2097-V34PR6-LM	99

Minimum Clearance Requirements

This section provides information to help you choose the size of your cabinet and the placement of your Kinetix 350 system components.

IMPORTANT Mount the module in an upright position as shown. Do not mount the drive module on its side.

[Figure 3](#) illustrates minimum clearance requirements for proper airflow and installation:

- Additional clearance is required depending on the accessory items installed.
- An additional 9.7 mm (0.38 in.) clearance is required left of the drive if the I/O expansion terminal block is used.
- An additional 26 mm (1.0 in.) clearance is required right of the drive when the heatsink is present.
- An additional 36 mm (1.42 in.) is required right of the drive when the side-mount line filter is present. An additional 50 mm (2.0 in.) is required behind the drive when the rear-mount line filter is present.
- An additional 5.0 mm (0.19 in.) clearance is required in front of the drive when the 2090-K2CK-D15M feedback connector kit is used.
- Additional clearance is required for the cables and wires that are connected to the top, front, and bottom of the drive.
- An additional 150 mm (6.0 in.) is required when the drive is mounted next to noise sensitive equipment or clean wireways.

See Kinetix 350 Drive Power Specifications in Kinetix Servo Drives Specifications Technical Data, publication [KNX-TD003](#) for Kinetix 350 drive dimensions.

Figure 3 - Minimum Clearance Requirements

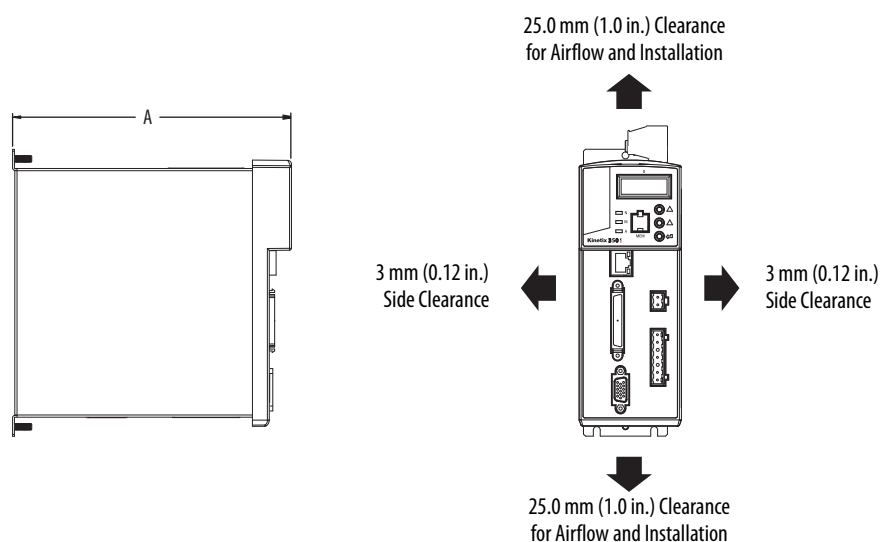

Drive Cat. No.	A
2097-V31PR0-LM	185 (7.29)
2097-V31PR2-LM	185 (7.29)
2097-V32PR0-LM	230 (9.04)
2097-V32PR2-LM	230 (9.04)
2097-V32PR4-LM	230 (9.04)
2097-V33PR1-LM	185 (7.29)
2097-V33PR3-LM	185 (7.29)
2097-V33PR5-LM	185 (7.29)
2097-V33PR6-LM	230 (9.04)
2097-V34PR3-LM	185 (7.29)
2097-V34PR5-LM	185 (7.29)
2097-V34PR6-LM	230 (9.04)

See [page 22](#) for power dissipation specifications.

Electrical Noise Reduction

This section outlines practices that minimize the possibility of noise-related failures as they apply specifically to Kinetix 350 system installations. For more information on the concept of high-frequency (HF) bonding, the ground plane principle, and electrical noise reduction, refer to the System Design for Control of Electrical Noise Reference Manual, publication [GMC-RM001](#).

Bonding Drives

Bonding is the practice where you connect metal chassis, assemblies, frames, shields, and enclosures to reduce the effects of electromagnetic interference (EMI).

Unless specified, most paints are not conductive and act as insulators. To achieve a good bond between drive and the subpanel, surfaces must be paint-free or plated. Bonded metal surfaces create a low-impedance return path for high-frequency energy.

IMPORTANT To improve the bond between the drive and subpanel, construct your subpanel out of zinc plated (paint-free) steel.

Improper bonding of metal surfaces blocks the direct return path and lets high-frequency energy travel elsewhere in the cabinet. Excessive high-frequency energy can affect the operation of other microprocessor controlled equipment.

These illustrations show recommended bonding practices for painted panels, enclosures, and mounting brackets.

Figure 4 - Recommended Bonding Practices for Painted Panels

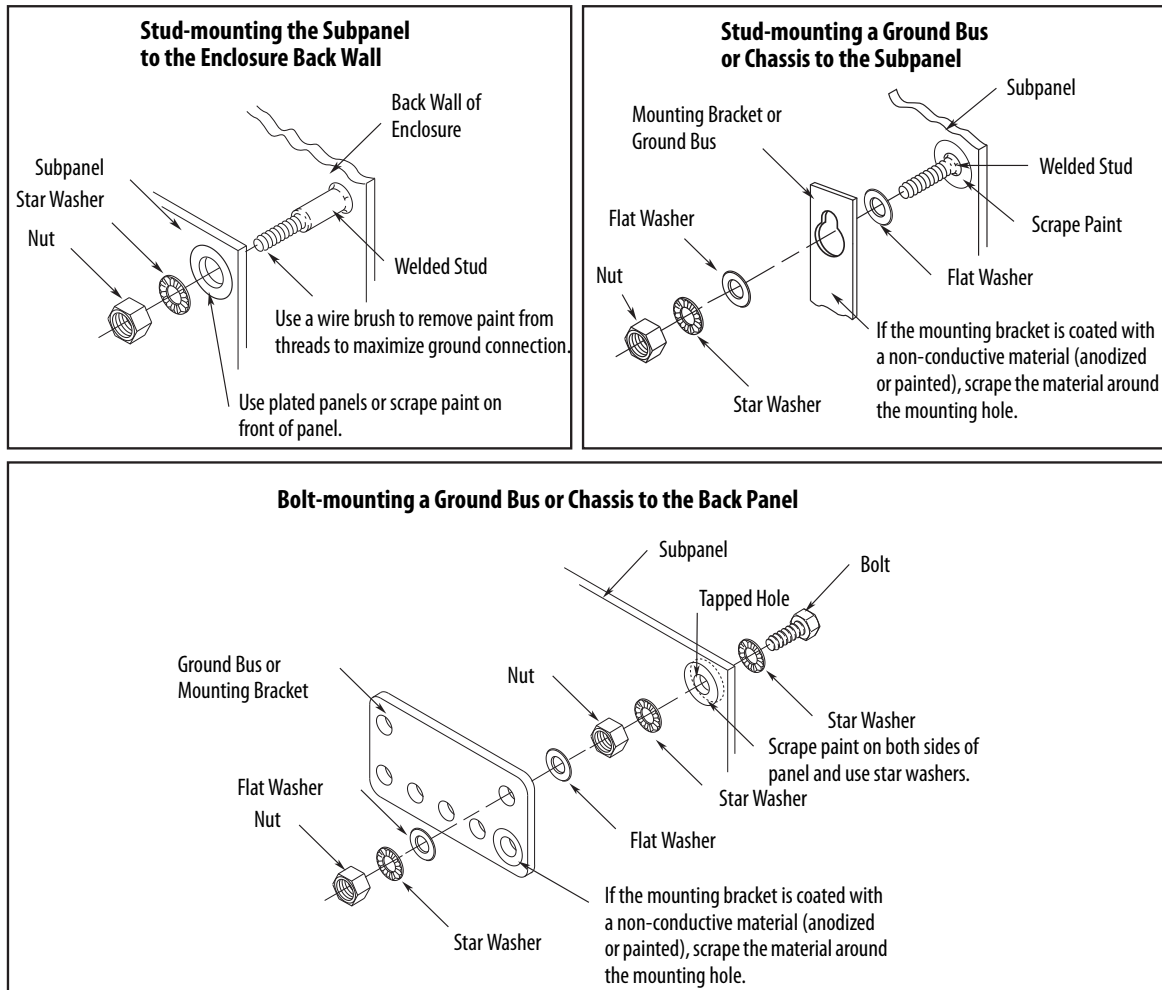

Bonding Multiple Subpanels

Bonding multiple subpanels creates a common low-impedance exit path for the high frequency energy inside the cabinet. Subpanels that are not bonded together cannot share a common low impedance path. This difference in impedance can affect networks and other devices that span multiple panels:

- Bond the top and bottom of each subpanel to the cabinet by using 25.4 mm (1.0 in.) by 6.35 mm (0.25 in.) wire braid. As a rule, the wider and shorter the braid is, the better the bond.
- Scrape the paint from around each fastener to maximize metal-to-metal contact.

Figure 5 - Multiple Subpanels and Cabinet Recommendations

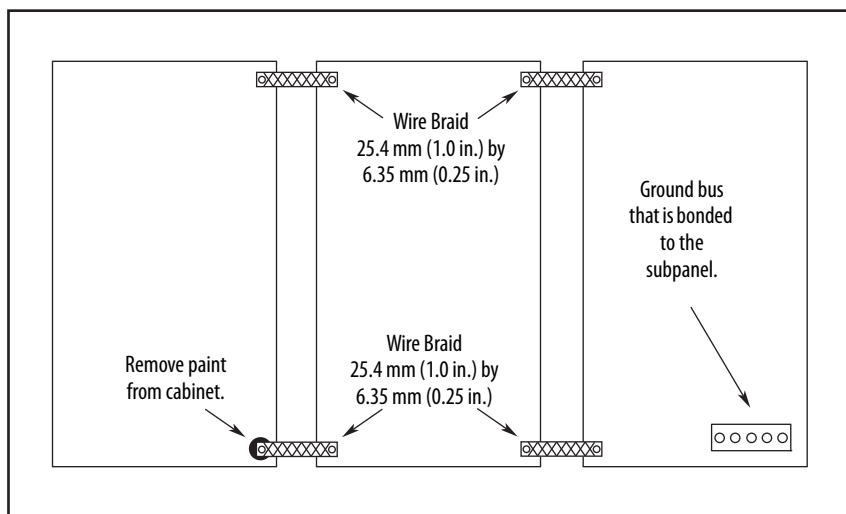

Establish Noise Zones

Observe these guidelines when individual input power components are used in the Kinetix 350 system:

- The clean zone (C) exits left of the Kinetix 350 system and includes the I/O wiring, feedback cable, Ethernet cable, and DC filter (gray wireway).
- The dirty zone (D) exits right of the Kinetix 350 system (black wireway) and includes the circuit breakers, transformer, 24V DC power supply, contactors, AC line filter, motor power, and safety cables.
- The very dirty zone (VD) is limited to where the AC line (EMC) filter VAC output jumpers over to the drive. Shielded cable is required only if the very dirty cables enter a wireway.

Figure 6 - Noise Zones (Bulletin 2090 AC line filters)

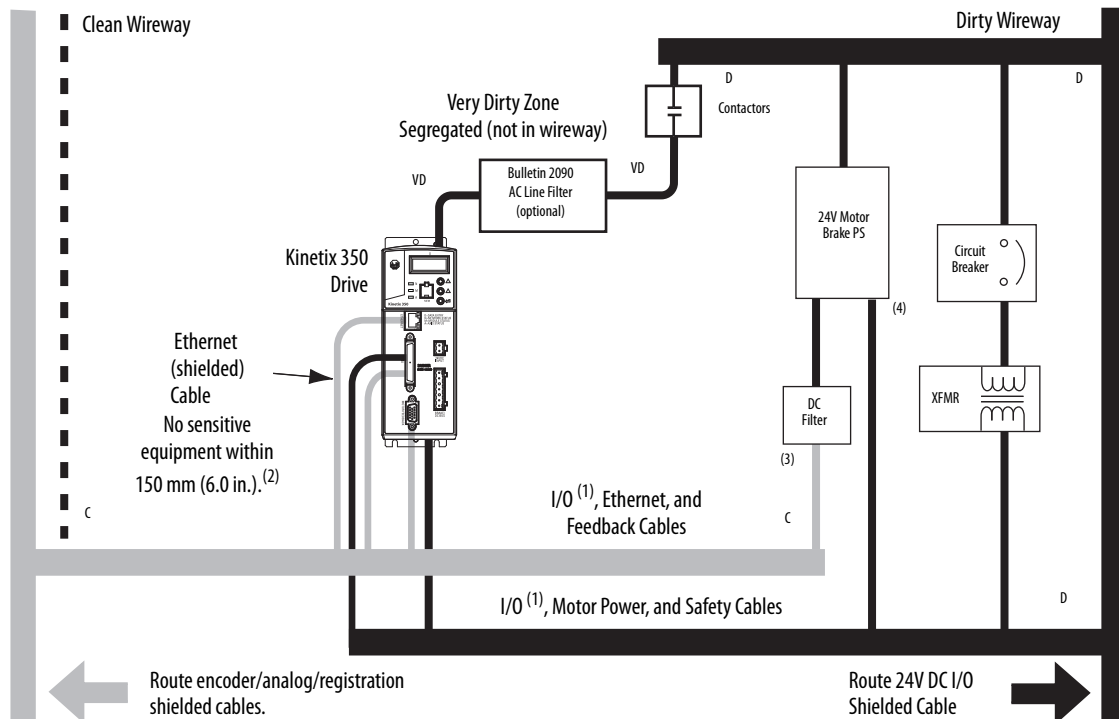

- (1) If drive system I/O cable contains (dirty) relay wires, route cable in dirty wireway.
- (2) For tight spaces, use a grounded steel shield. For examples, refer to the System Design for Control of Electrical Noise Reference Manual, publication [GMC-RM001](#).
- (3) This voltage is a clean 24V DC available for any device that requires it. The 24V enters the clean wireway and exits to the left.
- (4) This voltage is a dirty 24V DC available for motor brakes and contactors. The 24V enters the dirty wireway and exits to the right.

Cable Categories for Kinetix 350 Drive Components

This table indicates the zoning requirements of cables that are connected to the Kinetix 350 drive components.

Table 11 - Kinetix 350 Drive Components

Wire/Cable	Connector	Zone			Method	
		Very Dirty	Dirty	Clean	Ferrite Sleeve	Shielded Cable
L1, L2, L3 (unshielded cable)	IPD	X				
U, V, W (motor power)	MP		X			X
B+-, B-, BR (shunt resistor)	BC		X			
24V DC	BP			X		
Control COM, 24V DC control, safety enable, and feedback signals for safe-off feature	STO		X			
Motor feedback	MF			X		X
Registration	IOD			X		X
Others			X			
Ethernet	Port 1			X		X

Noise Reduction Guidelines for Drive Accessories

See this section when mounting an AC line filter or shunt resistor module for guidelines that are designed to reduce system failures that excessive electrical noises cause.

AC Line Filters

If you are using a Bulletin 2090 line filter, mount the filter on the same panel as the Kinetix 350 drive, and as close to the drive as possible.

Observe these guidelines when mounting your AC line filter:

- Good HF bonding to the panel is critical. For painted panels, refer to the examples on [page 24](#).
- Segregate input and output wiring as far as possible.

Shunt Resistors

Observe these guidelines when mounting your shunt resistor outside the enclosure:

- Mount shunt resistor and wiring in the very dirty zone or in an external shielded enclosure.
- Mount resistors in a shielded and ventilated enclosure outside the cabinet.
- Keep unshielded wiring as short as possible. Keep shunt wiring as flat to the cabinet as possible.

Figure 8 - Shunt Resistor Outside the Enclosure

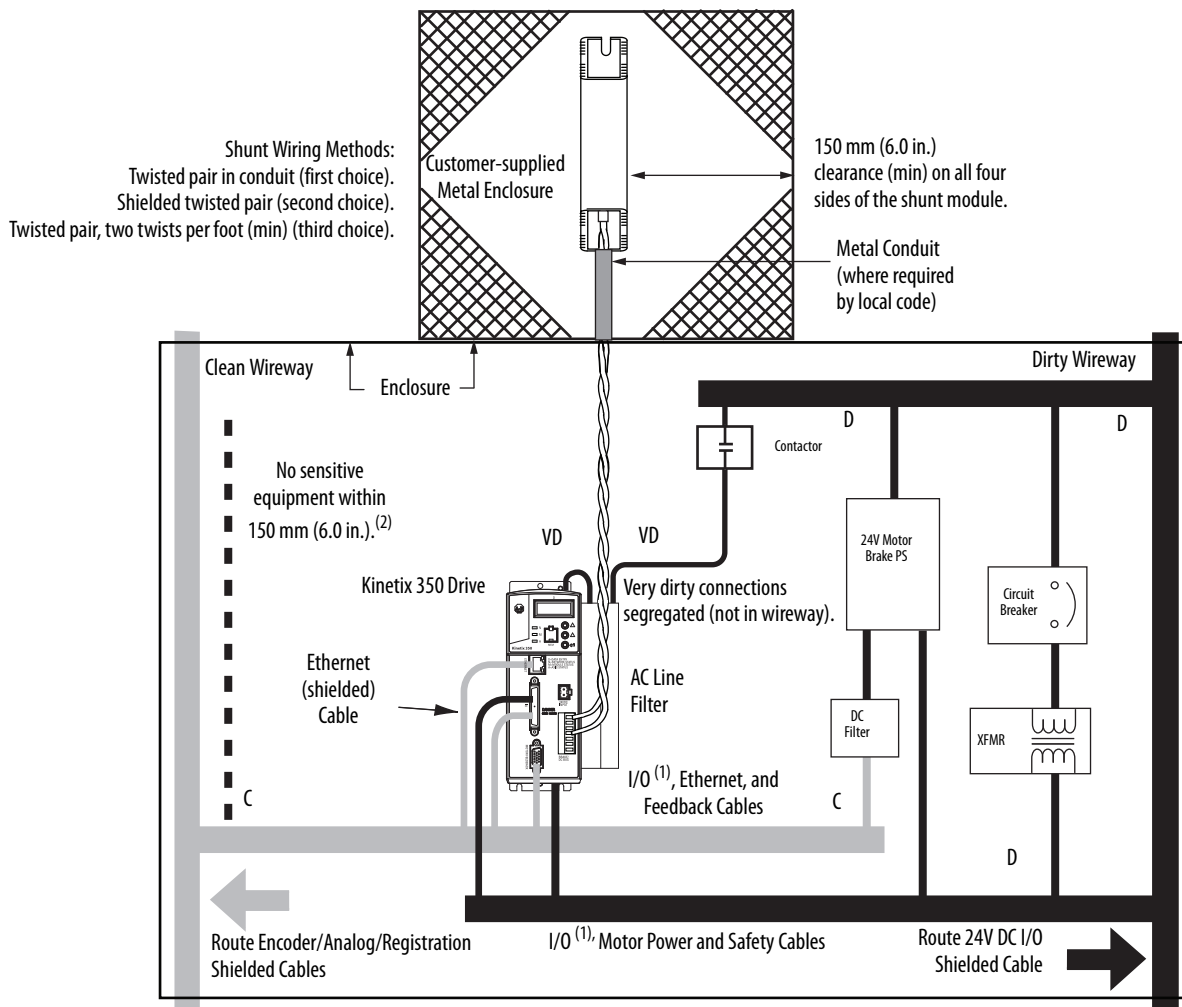

(1) If drive system I/O cable contains (dirty) relay wires, route cable in dirty wire way.
 (2) When space does not permit 150 mm (6.0 in.) clearance, install a grounded steel shield between the drive and clean wireway. For examples, refer to the System Design for Control of Electrical Noise Reference Manual, publication [GMC-RM001](#).

When mounting your shunt module inside the enclosure, follow these additional guidelines:

- Mount the shunt resistor anywhere in the dirty zone, but as close to the Kinetix 350 drive as possible.
- Shunt wires can be run with motor power cables.
- Keep unshielded wiring as short as possible. Keep shunt wiring as flat to the cabinet as possible.
- Separate shunt wires from other sensitive, low-voltage signal cables.

Figure 9 - Shunt Resistor inside the Enclosure

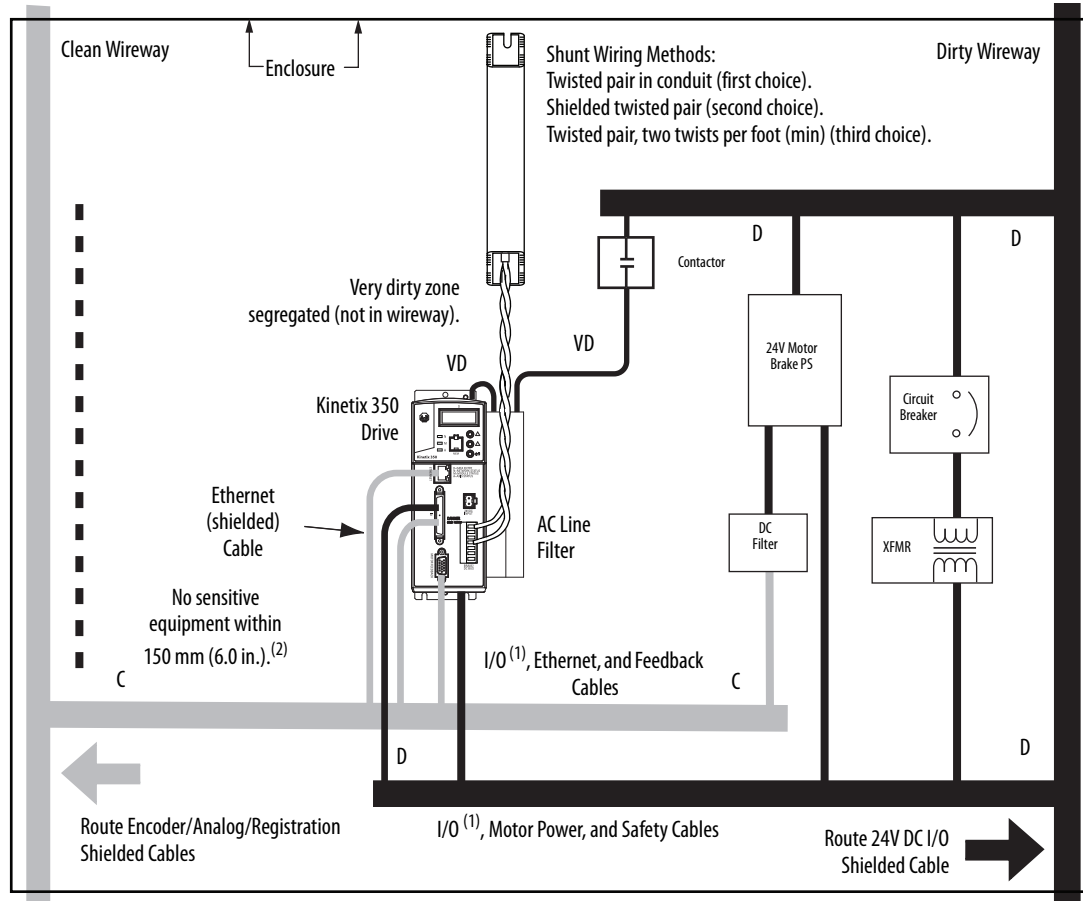

(1) If drive system I/O cable contains (dirty) relay wires, route cable in dirty wire way.

(2) When space does not permit 150 mm (6.0 in.) clearance, install a grounded steel shield between the drive and clean wireway. For examples, refer to the System Design for Control of Electrical Noise Reference Manual, publication [GMC-RM001](#).

Motor Brake

The brake is mounted inside the motor and how you connect to the drive depends on the motor series.

See [Kinetix 350 Drive/Rotary Motor Wiring Examples](#) that begin on [page 134](#) for the interconnect diagram of your drive/motor combination.

Mount Your Kinetix 350 Drive

This procedure assumes that you have prepared your panel and understand how to bond your system. For installation instructions regarding other equipment and accessories, refer to the instructions that came with those products.



ATTENTION: This drive contains electrostatic discharge (ESD) sensitive parts and assemblies. You are required to follow static control precautions when you install, test, service, or repair this assembly. If you do not follow ESD control procedures, components can be damaged. If you are not familiar with static control procedures, refer to *Guarding Against Electrostatic Damage*, publication [8000-4.5.2](#), or any other applicable ESD Protection Handbook.

Follow these steps to mount your Kinetix 350 drive.

1. Lay out the position for the Kinetix 350 drive and accessories in the enclosure.

See [Establish Noise Zones](#) on [page 27](#) for panel layout recommendations. Mounting hole dimensions for the Kinetix 350 drive are shown in *Kinetix Servo Drives Specifications Technical Data*, publication number [KNX-TD003](#).

2. Attach the Kinetix 350 drive to the cabinet, first by using the upper mounting slots of the drive and then the lower.

The recommended mounting hardware is M4 (#6-32) steel machine screws that are torqued to 1.1 N•m (9.8 lb•in). Observe bonding techniques as described in [Bonding Drives](#) on [page 24](#).

IMPORTANT To improve the bond between the Kinetix 350 drive and subpanel, construct your subpanel out of zinc plated (paint-free) steel.

3. Tighten all mounting fasteners.

Kinetix 350 Drive Connector Data

Topic	Page
Kinetix 350 Drive Connectors and Indicators	34
Control Signal Specifications	39
Motor Feedback Specifications	44

Kinetix 350 Drive Connectors and Indicators

Although the physical size of the Kinetix® 350 drives vary, the location of the connectors and indicators is identical.

Figure 10 - Kinetix 350 Drive Connector and Indicators

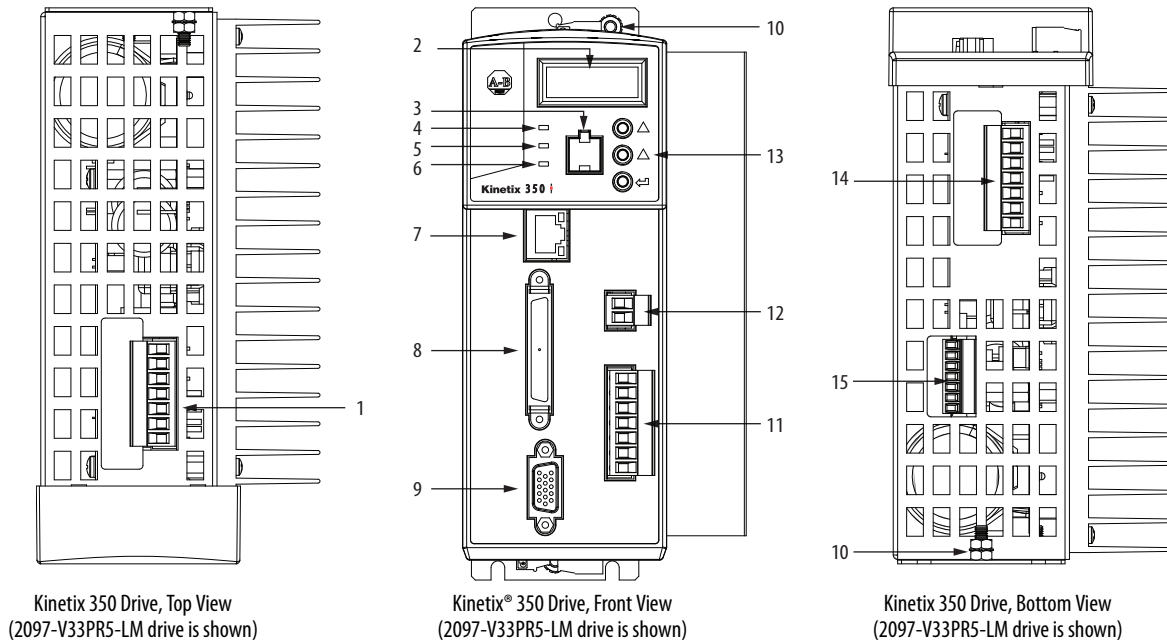

Item	Description
1	Mains (IPD) connector
2	Data status indicator and diagnostic display
3	Memory module socket
4	Network status indicator
5	Module status indicator
6	Axis status indicator
7	Ethernet communication port (Port 1)
8	I/O (IOD) connector

Item	Description
9	Motor feedback (MF) connector
10	Ground lug
11	Shunt resistor and DC bus (BC) connector
12	Back-up power (BP) connector
13	Display control push buttons (3)
14	Motor power (MP) connector
15	Safe torque-off (STO) connector

Table 12 - Kinetix 350 Drive Connectors

Designator	Description	Connector
IPD	AC input power	3-position or 4-position plug/header
PORT1	Ethernet communication port	RJ45 Ethernet
IOD	I/O	SCSI 50-pin high-density connector
MF	Motor feedback	15-pin high-density D-shell (male)
BP	Back-up power	2-pin quick-connect terminal block
BC	Shunt Resistor and DC Bus	7-pin quick-connect terminal block
MP	Motor power	6-pin quick-connect terminal block
STO	Safe torque off (STO) Terminal	6-pin quick-connect terminal block

Safe Torque-off Connector Pinout

The Kinetix 350 drive ships with the (6-pin) wiring-plug header that connects your safety circuit to the Kinetix 350 drive safe torque-off (STO) connector. If your system does not use the safe torque-off feature, follow instructions in [Safe Torque-off Feature Bypass](#) starting on [page 107](#) to wire the drive with motion-allowed jumpers.

Figure 11 - Safe Torque-off Connector

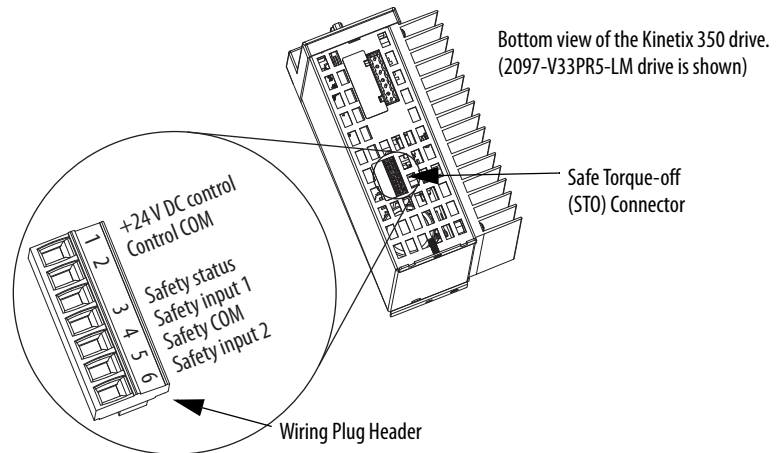

Table 13 - Kinetix 350 Drive Safe Torque-off Connector Pinout

STO Pin	Description	Signal
1	+24V DC output from the drive	+24V DC control
2	+24V DC output common	Control COM
3	Safety status	Safety Status
4	Safety input 1 (+24V DC to enable)	Safety Input 1
5	Safety common	Safety COM
6	Safety input 2 (+24V DC to enable)	Safety Input 2

IMPORTANT Use only pins STO-1 (+24V DC Control) and STO-2 (Control COM) of the motion-allowed jumpers to enable the drive when the safe torque-off function is not used. When the safe torque-off function is in operation, the 24V supply must come from an external source.

I/O Connector Pinout

IOD Pin	Description	Signal
1...25	Reserved	Reserved
26	+/- Overtravel, enable, and home common	COM
27	Negative hardware overtravel	NEG_OT
28	Positive hardware overtravel	POS_OT
29	Drive enable	ENABLE
30	Home switch	HOME_SW
31...35	Reserved	—
36	Registration common	REG_COM
37...38	Reserved	—
39	Registration input	REG
40...42	Reserved	—
43	Motor brake release positive	MTR_BRAKE+
44	Motor brake release negative	MTR_BRAKE-
44...50	Reserved	—

Figure 12 - Pin Orientation for 50-pin SCSI I/O (IOD) Connector

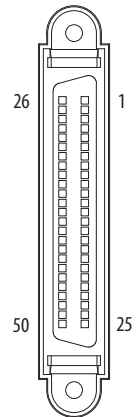

Motor Feedback (MF) Connector Pinout

MF Pin	Description	Signal
1	Sine differential input+ AM+ differential input+	SIN+ AM+
2	Sine differential input- AM- differential input-	SIN- AM-
3	Cosine differential input+ BM+ differential input+	COS+ BM+
4	Cosine differential input- BM- differential input-	COS- BM-
5	Data differential input + Index pulse+	DATA+ IM+
6	Common	ECOM
7	Encoder power (+9V)	EPWR_9V ⁽²⁾
8	Single-ended 5V Hall effect commutation	S3

MF Pin	Description	Signal
9	Reserved	—
10	Data differential input - Index pulse-	DATA- IM-
11	Motor thermal switch (normally closed) ⁽¹⁾	TS
12	Single-ended 5V Hall effect commutation	S1
13	Single-ended 5V Hall effect commutation	S2
14	Encoder power (+5V)	EPWR_5V ⁽²⁾
15	Reserved	—

- (1) Not applicable unless motor has integrated thermal protection.
- (2) Encoder power supply uses either 5V or 9V DC based on encoder/motor used.

IMPORTANT Drive-to-motor power and feedback cable length must not exceed 20 m (65.6 ft). System performance was tested at these specifications and also apply when meeting CE requirements.

Figure 13 - Pin Orientation for 15-pin Motor Feedback (MF) Connector

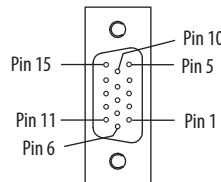

Ethernet Communication Connector Pinout

Port 1 Pin	Description	Signal
1	Transmit port (+) data terminal	+ TX
2	Transmit port (-) data terminal	- TX
3	Receive port (+) data terminal	+ RX
4	—	—

Port 1 Pin	Description	Signal
5	—	—
6	Receive port (-) data terminal	- RX
7	—	—
8	—	—

Figure 14 - Pin Orientation for 8-pin Ethernet Communication (port 1) Port

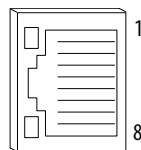

AC Input Power Connector Pinout

IPD Designator	Description (2097-V31PRx-LM drives)	Signal
L2/N	AC power in (non-doubler operation)	L2/N
L1	AC power in	L1
N	AC power neutral (only 120V doubler)	N
PE	Protective earth (ground)	PE

IPD Designator	Description (2097-V32PRx-LM drives)	Signal
L2	AC power in	L2
L1	AC power in	L1
PE	Protective earth (ground)	PE

IPD Designator	Description (2097-V33PRx-LM, and 2097-V34PRx-LM drives)	Signal
L3	AC power in (three-phase models)	L3
L2	AC power in	L2
L1	AC power in	L1
PE	Protective earth (ground)	PE

Back-up Power Connector Pinout

BP Designator	Description	Signal
+24V	Positive 24V DC	+24V DC
-24V	24V DC power supply return	Return

Shunt Resistor and DC Bus Connector Pinout

BC Designator	Description	Signal
+	Positive DC bus and shunt resistor	+
+		+
SH	Shunt resistor	SH
-	Negative DC bus	-
-		-

Motor Power Connector Pinout

MP Designator	Description	Signal
PE	Protective earth (ground)	PE
W	Motor power out	W
V	Motor power out	V
U	Motor power out	U

Control Signal Specifications

This section provides a description of the Kinetix 350 drive I/O (IOD), communication, shunt resistor and DC bus (BC), and back-up power (BP) connectors.

Digital Inputs

Five fixed inputs are available for the machine interface on the Kinetix 350 drive.

IMPORTANT To improve registration input EMC performance, refer to the System Design for Control of Electrical Noise Reference Manual, publication [GMC-RM001](#).

IMPORTANT Over-travel limit input devices must be normally closed.

The five digital inputs (IOD-27...IOD-30 and IOD-39) have fixed pin assignments.

Table 14 - Understanding Digital Inputs

IOD Pin	Signal	Description	Capture Time	Edge/Level Sensitive
IOD-29	ENABLE	Optically isolated, single-ended active high signal. Current loading is nominally 9 mA. A 24V DC input is applied to this terminal to enable the axis.	0.5 ms	Level
IOD-30	HOME	Optically isolated, single-ended active high signal. Current loading is nominally 9 mA. Home switch (normally open contact) inputs axis require 24V DC (nominal).	0.5 ms	Edge
IOD-39	REG	Optically isolated, single-ended active high signal. Current loading is nominally 9 mA. A 24V DC input is applied or removed from this terminal to trigger registration event. Fast registration inputs are required to ensure the motor interface can capture the positional information with less than 5 μ s uncertainty.	5 μ s	Edge
IOD-27 IOD-28	NEG_OT POS_OT	Overtravel detection is available as an optically isolated, single-ended active high signal. Current loading is nominally 9 mA per input. The positive/negative limit switch (normally closed contact) inputs for axis require 24V DC (nominal).	1 ms	Level

Table 15 - Understanding Digital Input Functions

Function	Description	Behavior
Enable	If the controller configuration specifies checking of the enable input, an active state enables the power electronics to control the motor and an inactive state prevents motion. The drive generates an exception if the input is inactive when the controller commands motion and has authorized checking. The drive behavior in this situation is programmable.	By default drive enable input checking is enabled. If the checking is authorized and the input is disabled the drive issues a Drive Enable Start Inhibit and you are not able to issue a Servo On instruction from the controller. To disable the Enable function: <ul style="list-style-type: none"> • Tie input to 24V DC • Write a Logix Designer message instruction that changes enableInputChecking or Attribute 736 to zero, see instructions on page 100
Home	An active state indicates to a homing sequence that the referencing sensor has been seen. Typically, a transition of this signal is used to establish a reference position for the machine axis.	The function is always inactive unless armed by the controller.
Registration	An inactive-to-active transition (also known as a positive transition) or active-to-inactive transition (also known as a negative transition) is used to latch position values for use in registration moves.	
Positive Over-travel	If the controller configuration specifies checking of the hardware over-travel inputs, an inactive state indicates that a position limit has been exceeded in the positive direction. The drive generates an exception if the input is inactive when the controller authorizes checking. The drive behavior in this situation is programmable.	The function is always active. To disable function: <ul style="list-style-type: none"> • Tie input to 24V • Set to only Fault Status
Negative Over-travel	If the controller configuration specifies checking of the hardware overtravel inputs, an inactive state indicates that a position limit has been exceeded in the negative direction. The drive generates an exception if the input is inactive when the controller authorizes checking. The drive behavior in this situation is programmable.	

Table 16 - Digital Input Specifications

Attribute	Value
Type	Active high, single-ended, current sinking
Functions	Enable, Home, Positive Over-travel, Negative Over-travel, Registration
Input current (with 24V applied)	9 mA, max
On-state input voltage	4.2...24V @ 2...9 mA total
Off-state input voltage	0...2.5V
Pulse reject filtering (only Registration functions)	120 ns, nom
Pulse reject filtering, default (all other input functions, can be configured)	1.0 ms, nom
Propagation delay (only Registration function)	5 µs
Registration repeatability	200 ns
Input reaction time (Disable)	2 ms, max
Input reaction time (Enable, Positive Over-travel inputs)	2 ms, max

The digital inputs are optically isolated and sink up to 24V DC. Electrical details are shown in [Table 15](#) on [page 40](#). You can configure the inputs for PNP sourcing or NPN sinking.

Figure 15 - Sourcing of Digital Inputs

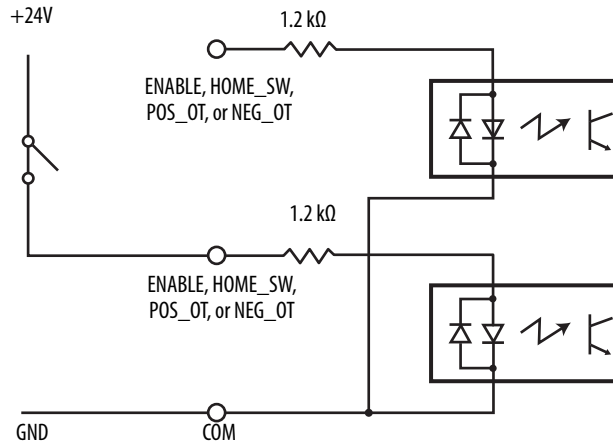

Figure 16 - Sinking of Digital Inputs

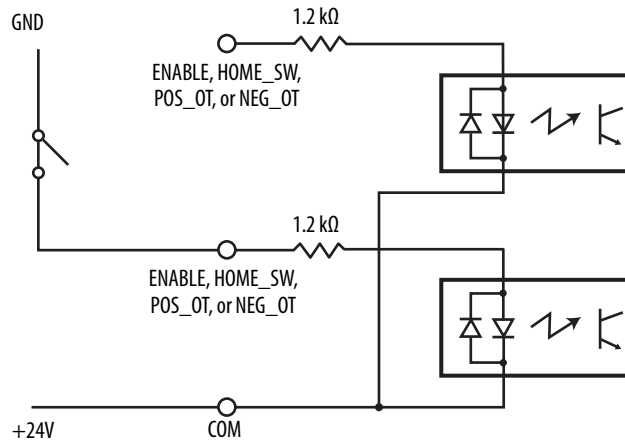

Figure 17 - Sourcing of Registration Digital Input

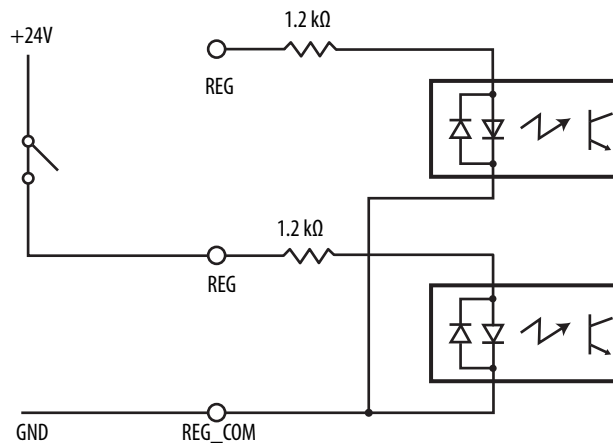
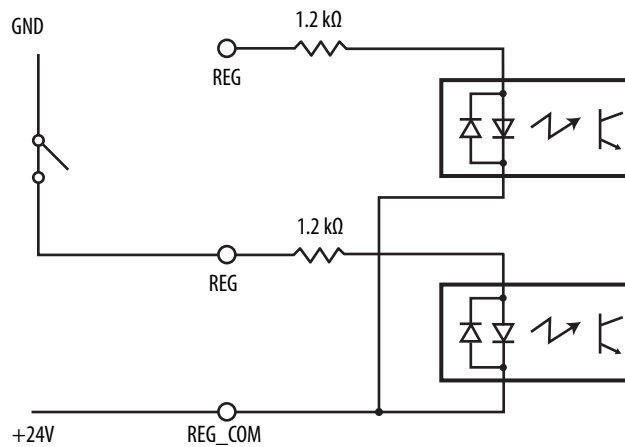

Figure 18 - Sinking of Registration Digital Input



Motor Brake Output

The two digital outputs (IOD-43 and IOD-44) have fixed pin assignments for motor brake function.

Attribute	Value
Circuit type	Optically isolated open collector/emitter
Voltage, max	30V DC
Current, max	100 mA

The following schematic shows how to wire your motor brake.

Figure 19 - Brake Wiring Schematic

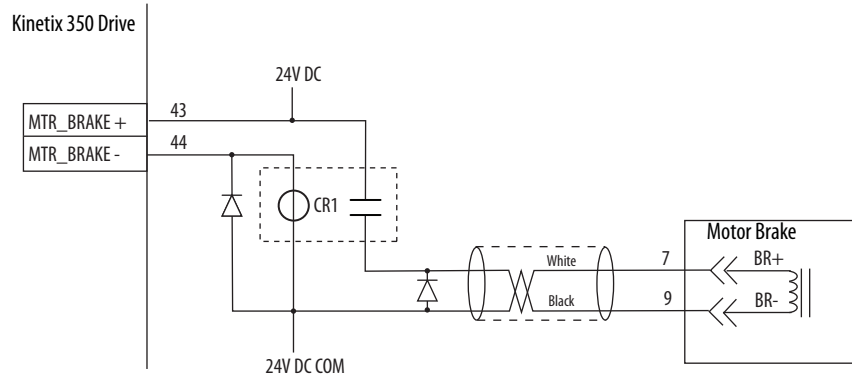

Use these guidelines to wire your brake:

- Connect a diode, 1N4004, an MOV (199-MSMD1), or equivalent, as shown, to both the relay and the motor brake coils.
- Wire the output as sourcing.
- The motor brake output is active on enable.
- Set the motor engage and disengage times that are based on the motor selected.

Ethernet Communication Specifications

An RJ45 10 Mbit Ethernet connector (port 1) is provided on the Kinetix 350 drive. It is fully compliant to the EtherNet/IP standard. Restrict the location of all Ethernet cabling to clean zones with minimal electromagnetic interference.

Attribute	Value
Communication	100BASE-TX, full duplex
Auto MDI/MDIX crossover detection/correction	Yes
Cabling	Rockwell Automation® CAT5E shielded, 100 m (328 ft), max

24V DC Back-up Power Specifications

The Kinetix 350 drive can use an external power supply to power the logic and communication circuits. If an independent 24V (@ 1 A) power supply is connected to the BP connector, the logic and communication circuits remain active during a mains input power loss.

Attribute	Value
Input voltage	20...26V DC
Current	500 mA
Inrush, max	30 A

Motor Feedback Specifications

The drive accepts motor feedback signals from the following types of encoders with these general specifications.

Table 17 - Motor Feedback General Specifications

Attribute	Value
Feedback device support	<ul style="list-style-type: none"> • Stegmann Hiperface • Generic TTL Incremental • Tamagawa 17-bit Serial
Power supply (EPWR5V)	5.13...5.67V, 400 mA, max
Power supply (EPWR9V)	8.3...9.9V, 275 mA, max
Thermostat	Single-ended, under 500 Ω = no fault, over 10 k Ω = fault

The Kinetix 350 drives support multiple types of feedback devices by using the 15-pin (MF) motor feedback connector and shared connector pins in many cases.

Table 18 - Motor Feedback Signals by Device Type

MF Pin	Stegmann Hiperface	Generic TTL Incremental	Tamagawa 17-bit Serial
1	SIN+	AM+	—
2	SIN-	AM-	—
3	COS+	BM+	—
4	COS-	BM-	—
5	DATA+	IM+	DATA+
6	ECOM	ECOM	ECOM
7	EPWR9V	—	—
8	—	S3	—
9	—	—	—
10	DATA-	IM-	DATA-
11	TS	TS	TS
12	—	S1	—
13	—	S2	—
14	EPWR5V	EPWR5V	EPWR5V
15	—	—	—

Figure 20 is the motor thermostat interface schematic. Although the thermostat signal is shown for all feedback types, some motors do not support this feature because it is not part of the feedback device.

Figure 20 - Motor Thermostat Interface

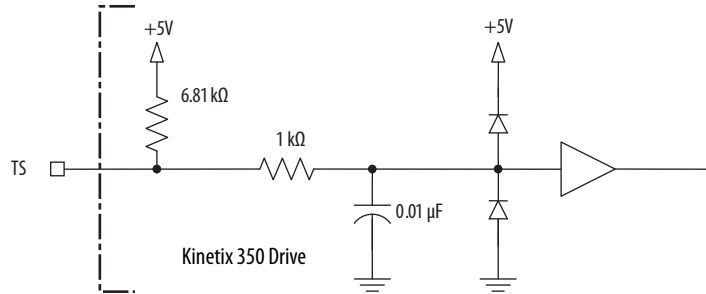

Table 19 - Motor Thermostat State Specifications

State	Resistance at TS ⁽¹⁾
No Fault	500 Ω
Fault	10 kΩ

(1) Resistance is measured between TS (MF pin 11) and ECOM (MF pin 6)

Table 20 - Stegmann Hiperface Specifications

Attribute	Value
Protocol	Hiperface
Memory support	Not programmed, or programmed with Allen-Bradley® motor data
Hiperface data communication	RS485, 9600 bps, 8 data bits, no parity
Sine/Cosine interpolation	2048 counts/sine period
Input frequency (AM/BM)	250 kHz, max
Input voltage (AM/BM)	0.6 . . 1.2V, p-p, measured at the drive inputs
Line loss detection (AM/BM)	Average ($\sin^2 + \cos^2$) > constant

Figure 21 - Stegmann Hiperface Interface, SIN and COS Signals

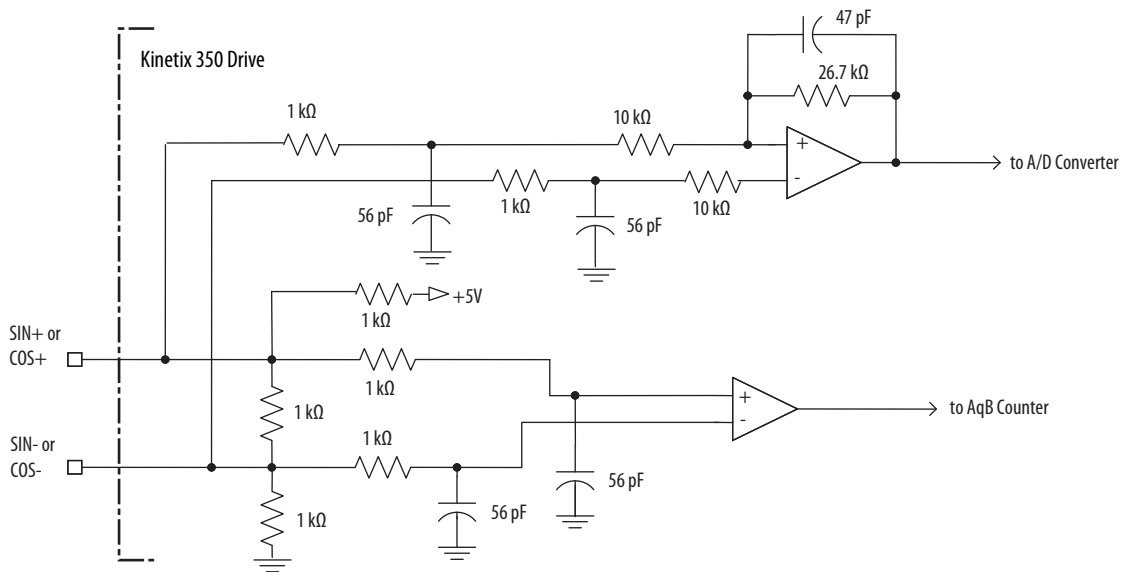

Figure 22 - Stegmann Hiperface Interface, DATA Signals

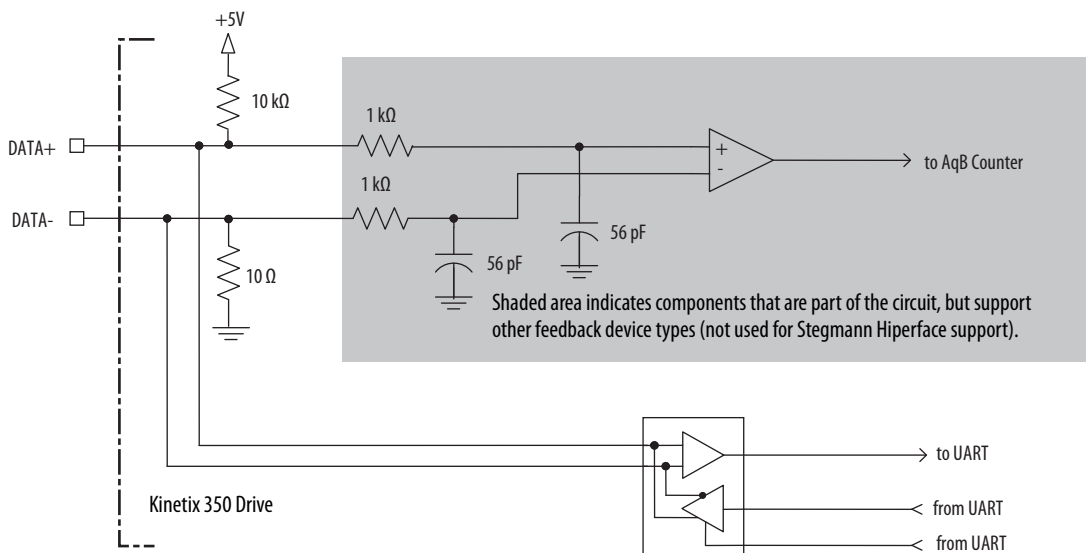

Table 21 - Generic TTL Incremental Specifications

Attribute	Value
TTL incremental encoder support	5V, differential A quad B
Quadrature interpolation	4 counts/square wave period
Differential input voltage (AM, BM, and IM)	1.0...7.0V
DC current draw (AM, BM, and IM)	30 mA, max
Input signal frequency (AM, BM, and IM)	5.0 MHz, max
Edge separation (AM and BM)	42 ns min, between any two edges
Line loss detection (AM and BM)	Average (AM ² + BM ²) > constant
Hall inputs (S1, S2, and S3)	Single-ended, TTL, open collector, or none

Figure 23 - Generic TTL Incremental, AM and BM Signals

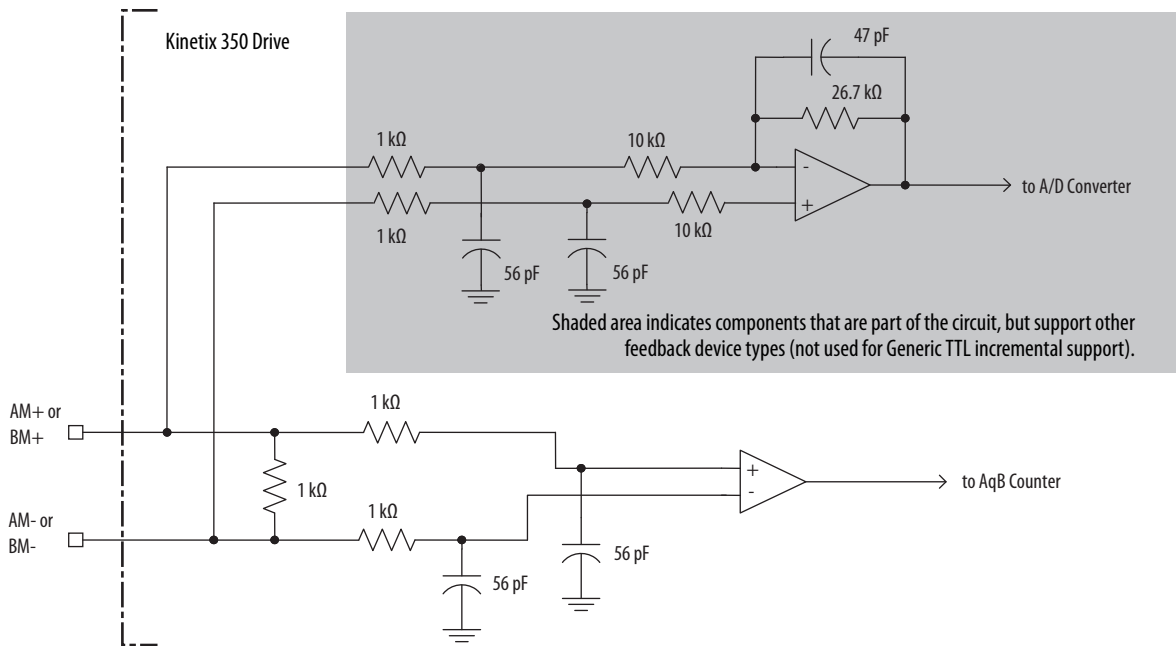

Figure 24 - Generic TTL Interface, IM Signals

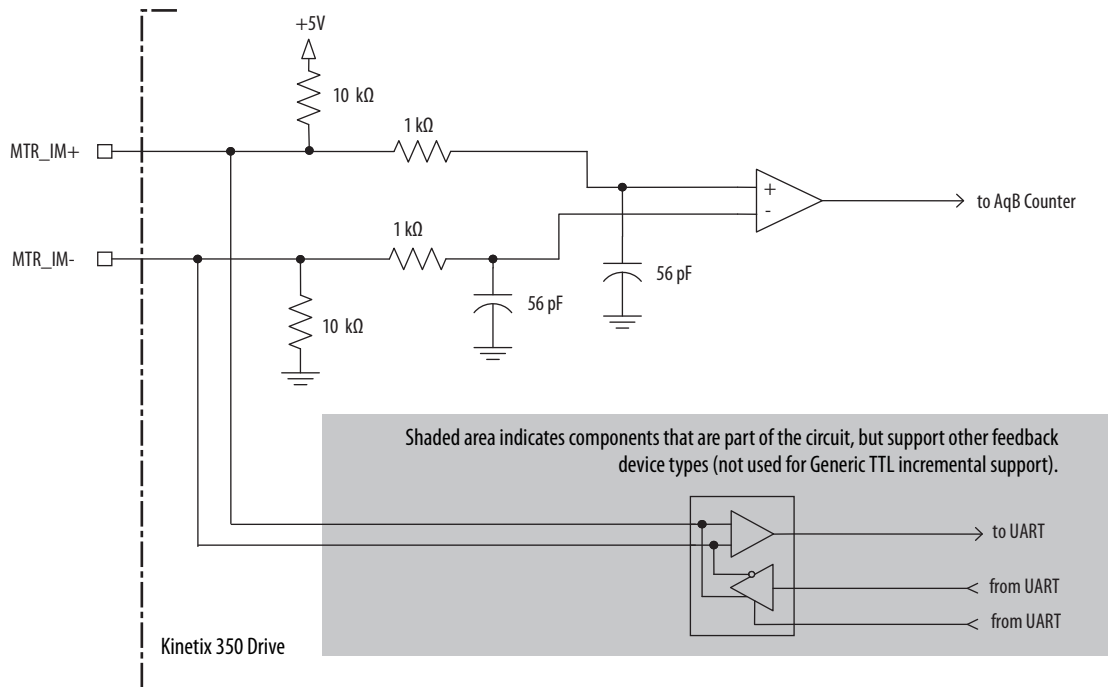

Figure 25 - Generic TTL Interface, S1, S2, or S3 Signals

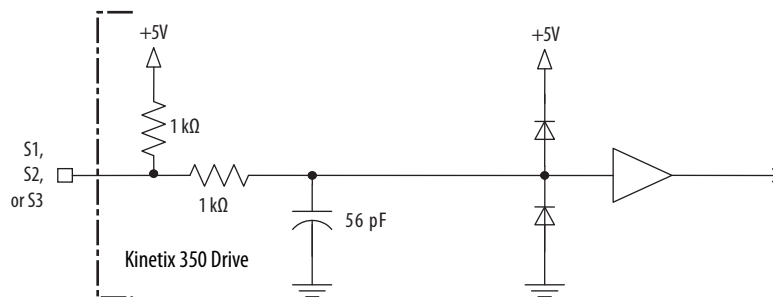

Table 22 - Tamagawa 17-bit Serial Specifications

Attribute	Value
Tamagawa model support	TSS669N124
Protocol	Tamagawa proprietary
Memory support	Programmed with Allen-Bradley motor data
Differential input voltage	1.0...7.0V
Data communication	2.5 Mbps, 8 data bits, no parity
Battery	3.6V, on external to drive in low-profile connector kit

See [Figure 22](#) for the Tamagawa 17-bit serial interface schematic. It is identical to the Stegmann Hiperface (DATA) signals schematic.

Feedback Power Supply

The Kinetix 350 drive generates +5V and +9V DC for motor feedback power. Short circuit protection and separate common mode filtering for each channel is included.

Table 23 - Motor Feedback Power Specifications

Supply	Reference	Voltage			Current mA	
		Min	Nominal	Max	Min	Max
+5V DC	EPWR_5V	5.13	5.4	5.67	0	400 ⁽¹⁾ ⁽²⁾
+9V DC	EPWR_9V	8.3	9.1	9.9	0	275 ⁽²⁾ ⁽³⁾

(1) 400 mA on the 5V supply with no load on the 9V supply.

(2) 300 mA on the 5V supply with 150 mA on the 9V supply.

(3) 275 mA on the 9V supply with no load on the 5V supply.

Figure 26 - Pin Orientation for 15-pin Motor Feedback (MF) Connector

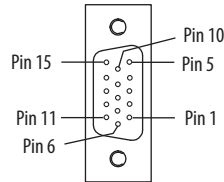

Notes:

Connect the Kinetix 350 Drive System

Topic	Page
Basic Wiring Requirements	51
Grounding Your Kinetix 350 Drive System	58
Power Wiring Requirements	60
Wiring Guidelines	61
Wiring the Kinetix 350 Drive Connectors	62
Apply the Motor Cable Shield Clamp	69
Feedback and I/O Cable Connections	70
Wiring the Feedback and I/O Connectors	72
Shunt Resistor Connections	74
Ethernet Cable Connections	74

Basic Wiring Requirements

This section contains basic information on how to wire the Kinetix® 350 drive.



ATTENTION: Plan the installation of your system so that you can cut, drill, tap, and weld with the system that is removed from the enclosure. Because the system is of the open type construction, be careful to keep any metal debris from falling into it. Metal debris or other foreign matter can become lodged in the circuitry, which can result in damage to components.



SHOCK HAZARD: To avoid hazard of electrical shock, perform all mounting and wiring of the Bulletin 2097 drive before you apply power. Once power is applied, connector terminals can have voltage present even when not in use.

IMPORTANT This section contains common PWM servo system wiring configurations, size, and practices that can be used in most applications. National Electrical Code, local electrical codes, special operating temperatures, duty cycles, or system configurations take precedence over the values and methods provided.

Recommended Cables

The [Motor Power Cable Compatibility](#) table on [page 65](#) and [Motor Feedback Cables for Specific Motor/Feedback Combinations](#) table on [page 70](#) show the cables Rockwell Automation® recommends that you use with the Kinetix® 350 drive.

IMPORTANT Factory-made cables are designed to minimize EMI and are recommended over hand-built cables to optimize system performance.

If it is necessary for you to build or modify your own cable, follow these guidelines:

- Connect the cable shield to the connector shells on both ends of the cable with a complete 360° connection.
- Use twisted-pair cable whenever possible. Twist differential signals with each other and twist single-ended signals with the appropriate ground return.

See the Kinetix Motion Control Selection Guide, publication [KNX-SG001](#), for low-profile connector kit, drive-end (mating) connector kit, and motor-end connector kit catalog numbers.

Route Power and Signal Wiring

When you route power and signal wiring on a machine or system, radiated noise from nearby relays, transformers, and other electronic drives can be induced into motor or encoder feedback signals, input/output communication, or other sensitive low voltage signals. Radiated noise can cause system faults and communication anomalies.

See [Electrical Noise Reduction](#) on [page 24](#) for examples of routing high and low voltage cables in wireways. See the System Design for Control of Electrical Noise Reference Manual, publication [GMC-RM001](#), for more information.

Determine the Input Power Configuration

This section contains examples of typical single-phase and three-phase facility input power that is wired to single-phase and three-phase Kinetix 350 drives.

The grounded power configuration lets you ground your single-phase or three-phase power at a neutral point. Match your secondary to one of the examples and be certain to include the grounded neutral connection. See [Table 68 on page 152](#) for leakage currents.

Three-phase Power Wired to Three-phase Drives

These examples illustrate grounded three-phase power that is wired to three-phase Kinetix 350 drives when phase-to-phase voltage is within drive specifications.

Figure 27 - Three-phase (400/480V) Power Configuration (WYE Secondary)

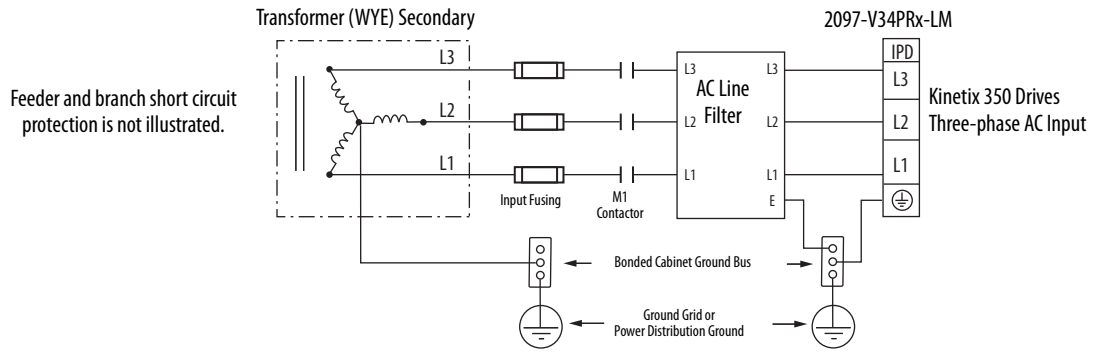

ATTENTION: For the 480V Kinetix 350 drives to meet proper voltage creepage and clearance requirements, each phase voltage to ground must be less than or equal to 300V AC rms. This requirement means that the power system must use a center grounded wye secondary configuration for 400/480V AC mains.

See Appendix C for leakage currents.

Figure 28 - Three-phase (240V) Power Configuration (Delta Secondary)

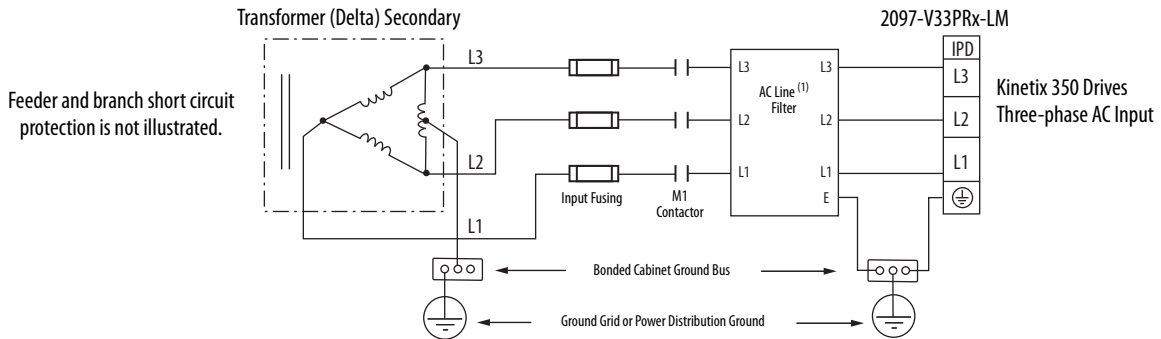

(1) Leakage current from the line filter, in this configuration, typically is higher than a balanced (center ground) configuration.

Figure 29 - Three-phase (240V) Power Configuration (Delta Secondary)

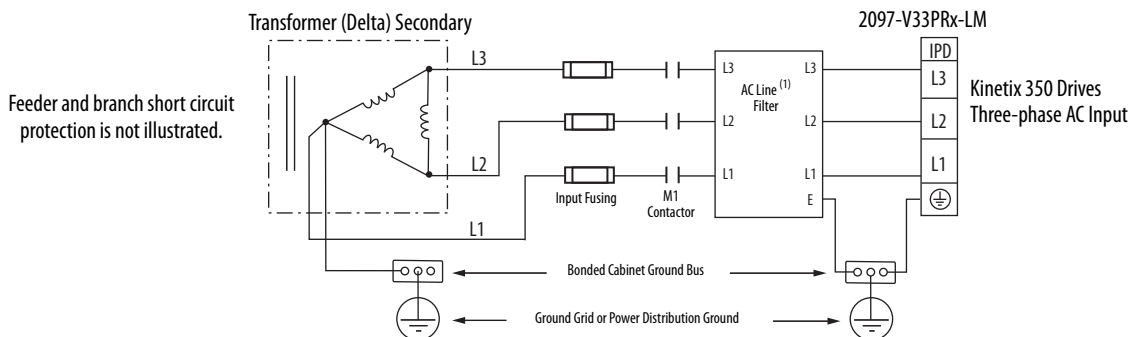

(1) Leakage current from the line filter, in this configuration, typically is higher than a balanced (center ground) configuration.

Single-phase Power Wired to Single-phase Drives

These examples illustrate grounded single-phase power that is wired to single-phase Kinetix 350 drives when phase-to-phase voltage is within drive specifications.

IMPORTANT The 2097-V32PRx-LM models have integrated AC line filters and do not require the AC line filter that is shown in this diagram.

Figure 30 - Single-phase Grounded Power Configurations

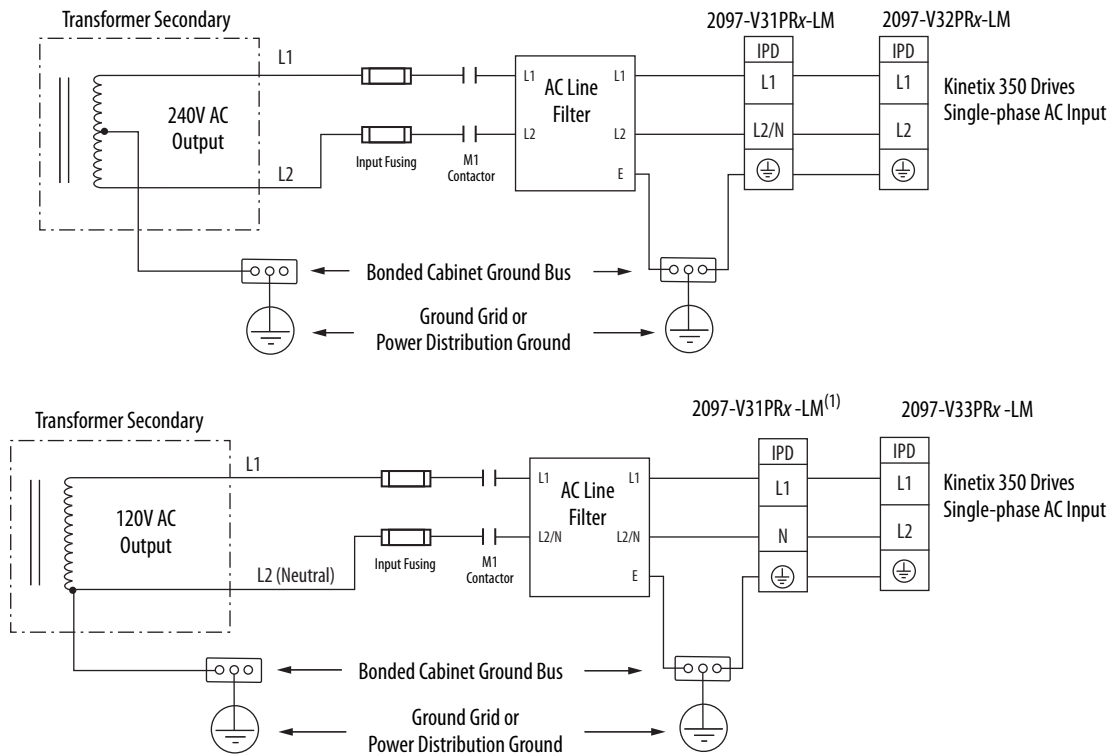

(1) This configuration applies to voltage-doubler operation for 2097-V31PRx-LM drives.

If you reduce transformer output, the motor speed is reduced. Feeder and branch short circuit protection is not illustrated.

Voltage Doubler Operation

You can wire the 2097-V31PRx-LM drives with 120V input voltage and achieve twice the output voltage. To use the voltage-doubler circuit, connect the 120V single-phase input power to the IPD-L1 and IPD-N terminals.

For Kinetix 350 drive power specifications, refer to Kinetix Servo Drives Specifications Technical Data, publication [KNX-TD003](#). For Kinetix 350 drive input wiring diagrams, refer to [Power Wiring Examples on page 131](#).

Isolation Transformer in Grounded Power Configurations

When you are using an isolation transformer, attach the chassis ground wire to the neutral connection. This grounded neutral connection does the following:

- Prevents the system from floating and avoids any high voltages that can otherwise occur, for example due to static electricity
- Provides a solid earth path for fault conditions



ATTENTION: If the supply transformer is an auto transformer (not recommended), do not add a chassis earth ground. A chassis earth ground is already included elsewhere in the system and addition of another creates a short.

Three-phase Power Wired to Single-phase Drives

This example illustrates grounded three-phase power that is wired to single-phase Kinetix 350 drives when phase-to-phase voltage is within drive specifications.

Figure 31 - Single-phase Amplifiers on Three-phase Power (WYE)

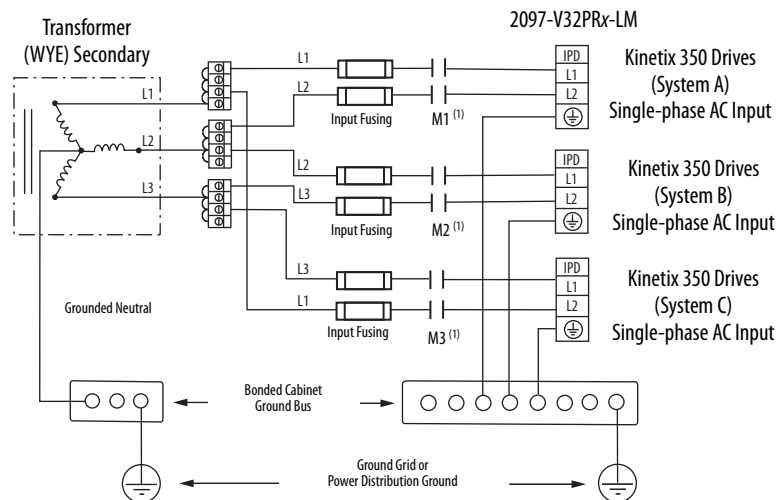

(1) Contactors (M1, M2, and M3) can be optional. For more information, see Understanding the Machinery Directive, publication [SHB-900](#). AC line filter is optional, but is required for CE compliance.

Feeder short circuit protection is not illustrated.

This example illustrates grounded three-phase power that is wired to single-phase Kinetix 350 drives when phase-to-phase voltage exceeds drive specifications.

A neutral must be connected when single-phase drives are attached to a three-phase isolating transformer secondary. It is not necessary that all three-phases be loaded with drives, but each drive must have its power return via the neutral connection



ATTENTION: Failure to connect the neutral can result in supply voltage swings at the individual drives. This condition occurs when the neutral point moves vectorially as a result of load variations that individual drives experience. The supply voltage swing can cause undervoltage and overvoltage trips on the drives, and the drive can be damaged if the overvoltage limit is exceeded.

Figure 32 - Single-phase Amplifiers (One AC Line Filter Per Drive)

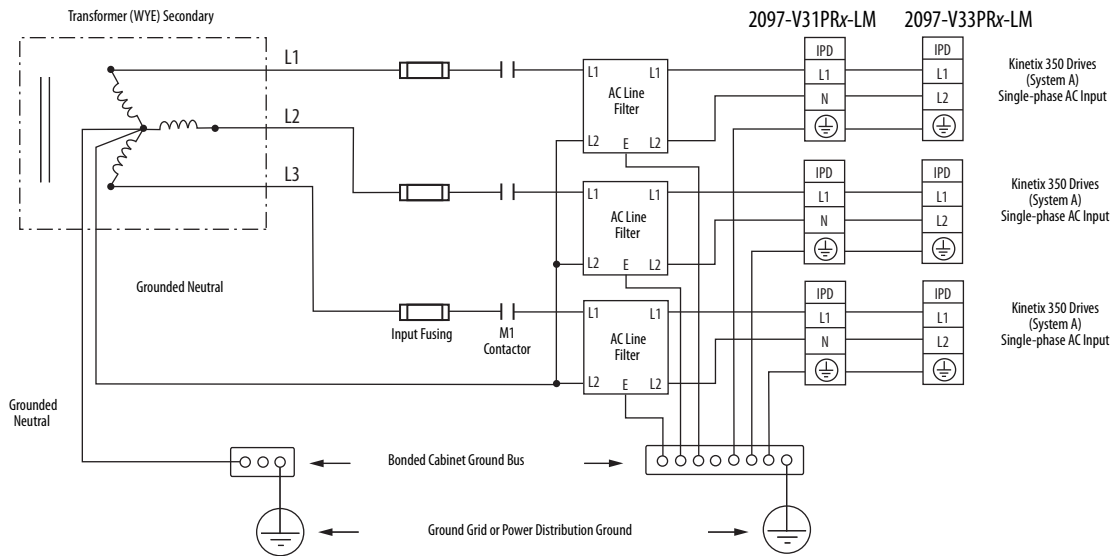

Feeder and branch short circuit protection is not illustrated.

IMPORTANT An AC line filter for each drive is the preferred configuration and required for CE compliance.

Voiding of CE Compliance

The three-phase and neutral in-line filter applications that are described [Three-phase Power Wired to Single-phase Drives on page 55](#) are not adequate for CE compliance for EMC. Therefore, EMC validity and CE marking by Rockwell Automation is voided when three-phase and neutral in line filters are used.



ATTENTION: The three-phase isolation transformer and neutral in-line filter applications that are described in this document have not been tested for EMC by Rockwell Automation. The products that are used in such installations are not considered CE marked by Rockwell Automation.

If this three-phase isolation transformer and neutral in-line filter application is used, the responsibility for EMC validation lies with the user and CE marking of the system becomes your responsibility.

If CE compliance is a customer requirement, use single-phase line filters that Rockwell Automation has tested and are specified for the product. See Kinetix Servo Drives Specifications Technical Data, publication [KNX-TD003](#) for catalog numbers.

Grounding Your Kinetix 350 Drive System

All equipment and components of a machine or process system must have a common earth ground point that is connected to their chassis. A grounded system provides a safety ground path for short circuit protection. Grounding your modules and panels minimize shock hazard to personnel and damage to equipment caused by short circuits, transient overvoltages, and accidental connection of energized conductors to the equipment chassis. For CE grounding requirements, refer to [CE Requirements](#) in [Chapter 1](#).

IMPORTANT To improve the bond between the Kinetix 350 drive and subpanel, construct your subpanel out of zinc plated (paint-free) steel.

Ground Your Drive to the System Subpanel



ATTENTION: The National Electrical Code contains grounding requirements, conventions, and definitions. Follow all applicable local codes and regulations to ground your system safely. See the [Figure 33](#) for details on grounding your Kinetix 350 drive. See [Appendix A](#) for the power wiring diagram for your Kinetix 350 drive.

If the Kinetix 350 drive is mounted on a painted subpanel, ground the drive to a bonded cabinet ground bus by using a braided ground strap or 4.0 mm² (12 AWG) solid copper wire 100 mm (3.9 in.) long.

Figure 33 - Connecting the Braided Ground Strap Example

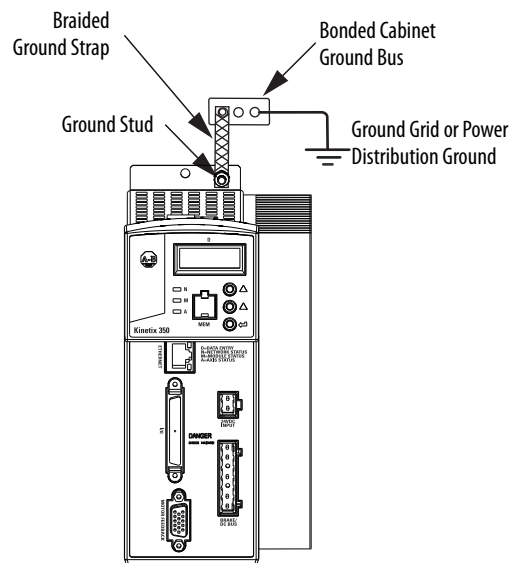

For drive dimensions, refer to Product Dimensions in Kinetix Servo Drives Specifications Technical Data, publication [KNX-TD003](#).

Figure 34 - Chassis Ground Configuration (Multiple Kinetix 350 Drives on One Panel)

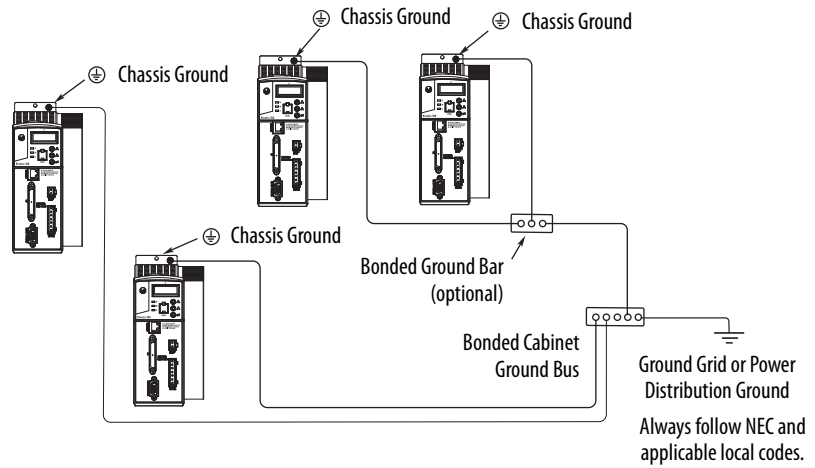

Ground Multiple Subpanels

To ground multiple subpanels, refer to the [Figure 35](#) HF bonding is not illustrated. For information, see [Bonding Multiple Subpanels](#) on [page 26](#).

Figure 35 - Subpanels Connected to a Single Ground Point

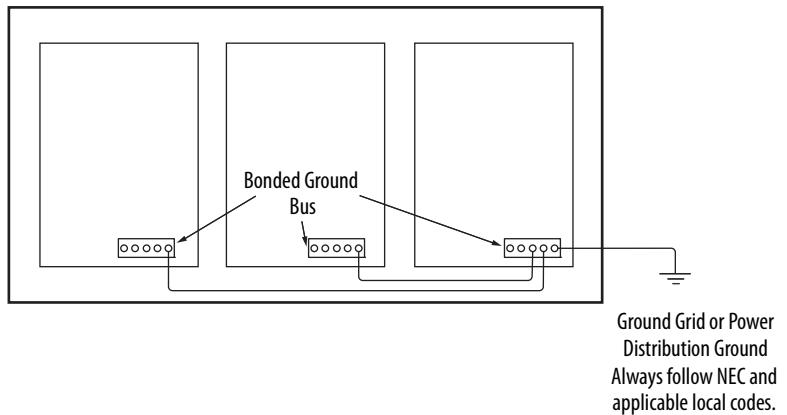

Power Wiring Requirements

The wire must be made of copper with 75 °C (167 °F) minimum rating. Phasing of main AC power is arbitrary and an earth ground connection is required for safe and proper operation. See [Power Wiring Examples](#) on [page 131](#) for interconnect diagrams.

IMPORTANT The National Electrical Code and local electrical codes take precedence over the values and methods provided.

Table 24 - Kinetix 350 Drive Power Wiring Requirements

Cat. No.	Description	Terminals			Recommended Wire Size mm ² (AWG)	Strip Length mm (in.)	Torque Value N·m (lb·in)	
		Pins	Signals					
2097-V31PR0-LM 2097-V32PR0-LM 2097-V32PR2-LM 2097-V33PR1-LM 2097-V33PR3-LM 2097-V34PR3-LM 2097-V34PR5-LM 2097-V34PR6-LM	Mains input power (IPD connector)		L3 L2 L1 PE ⁽³⁾	L2/N L1 N PE ⁽⁴⁾	L2 L1 PE ⁽⁵⁾	Motor power cable depends on motor/drive combination.	7 (0.28)	0.5 (4.5)
2097-V32PR4-LM 2097-V33PR5-LM						4.0 (12)	7 (0.28)	0.5 (4.5)
2097-V31PR2-LM 2097-V33PR6-LM						6.0 (10)	7 (0.28)	0.56...0.79 (5.0...7.0)
2097-V31PR0-LM 2097-V31PR2-LM 2097-V32PR0-LM 2097-V32PR2-LM 2097-V32PR4-LM 2097-V33PR1-LM 2097-V33PR3-LM 2097-V33PR5-LM 2097-V34PR3-LM 2097-V34PR5-LM 2097-V34PR6-LM	Motor power (MP connector)		PE W V U			2.5 (14)	7 (0.28)	0.5 (4.5)
2097-V33PR6-LM						4.0 (12)	7 (0.28)	0.5 (4.5)
2097-V31PR0-LM 2097-V31PR2-LM 2097-V32PR0-LM 2097-V32PR2-LM 2097-V32PR4-LM 2097-V33PR1-LM 2097-V33PR3-LM 2097-V33PR5-LM 2097-V34PR3-LM 2097-V34PR5-LM 2097-V34PR6-LM	Shunt/DC Bus ⁽¹⁾ (BC connector)		+ + SH - -			2.5 (14)	7 (0.28)	0.5 (4.5)
2097-V33PR6-LM						4.0 (12)	7 (0.28)	0.5 (4.5)
2097-V3xPRx-LM	Control back-up power (BP connector)		+24V DC -24V DC					
2097-V3xPRx-LM	Safe torque-off (STO connector)	STO-1 ⁽²⁾ STO-2 ⁽²⁾ STO-3 STO-4 STO-5 STO-6	+24V DC Control Control COM Safety Status Safety Input 1 Safety COM Safety Input 2		1.5 (16)	6 (0.25)	0.5 (4.5)	

- (1) Use for only shunt resistor connection.
- (2) Use for bypassing only the STO circuit.
- (3) Applies to 2097-V33PRx-LM, and 2097-V34PRx-LM drive modules.
- (4) Applies to 2097-V31PRx-LM drive modules.
- (5) Applies to 2097-V32PRx-LM drive modules.



ATTENTION: To avoid personal injury and/or equipment damage, make sure that installation complies with specifications regarding wire types, conductor sizes, branch circuit protection, and disconnect devices. The National Electrical Code (NEC) and local codes outline provisions for safely installing electrical equipment.

To avoid personal injury and/or equipment damage, make sure that motor power connectors are used for only connection purposes. Do not use them to turn the unit on and off.

To avoid personal injury and/or equipment damage, make sure that shielded power cables are grounded to prevent potentially high voltages on the shield.

Wiring Guidelines

Use these guidelines as a reference when wiring the connectors on your Kinetix 350 drive power modules.

IMPORTANT For connector locations of the Kinetix 350 drives, refer to [Kinetix 350 Drive Connectors and Indicators](#) on [page 34](#).

When you tighten screws to secure the wires, refer to the tables that begin on [page 60](#) for torque values.

When you remove insulation from wires, refer to the tables that begin on [page 60](#) for strip lengths.

IMPORTANT To improve system performance, run wires and cables in the wireways as established in [Establish Noise Zones](#) on [page 27](#).

Follow these steps when wiring the connectors on your Kinetix 350 drive modules.

1. Prepare the wires for attachment to each connector plug by removing insulation equal to the recommended strip length.

IMPORTANT Use caution not to nick, cut, or otherwise damage strands as you remove the insulation.

2. Route the cable/wires to your Kinetix 350 drive.
3. Insert wires into connector plugs.
See connector pinout tables in [Chapter 3](#) or the interconnect diagrams in [Appendix A](#).
4. Tighten the connector screws.
5. Gently pull on each wire to make sure it does not come out of its terminal; reinsert and tighten any loose wires.
6. Insert the connector plug into the module connector.

Wiring the Kinetix 350 Drive Connectors

This section provides examples and wiring tables to assist you when you make connections to the Kinetix 350 drive.

Wire the Safe Torque-off (STO) Connector

For the safe torque-off (STO) connector pinouts, feature descriptions, and wiring information, see [Chapter 6](#) on [page 101](#).

Wire the Back-up Power (BP) Connector

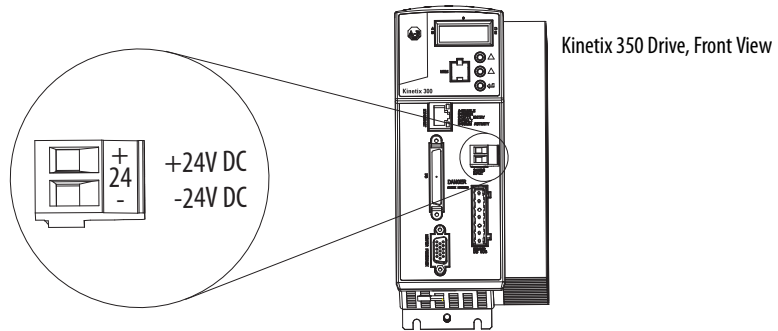

Table 25 - Back-up Power (BP) Connector

Drive Cat. No.	Terminals	Recommended Wire Size mm ² (AWG)	Strip Length mm (in.)	Torque Value N·m (lb·in)
2097-V3xPRx-LM	+24V DC	1.5 (16)	6 (0.25)	0.5 (4.5)
	-24V DC			

Wire the Input Power (IPD) Connector

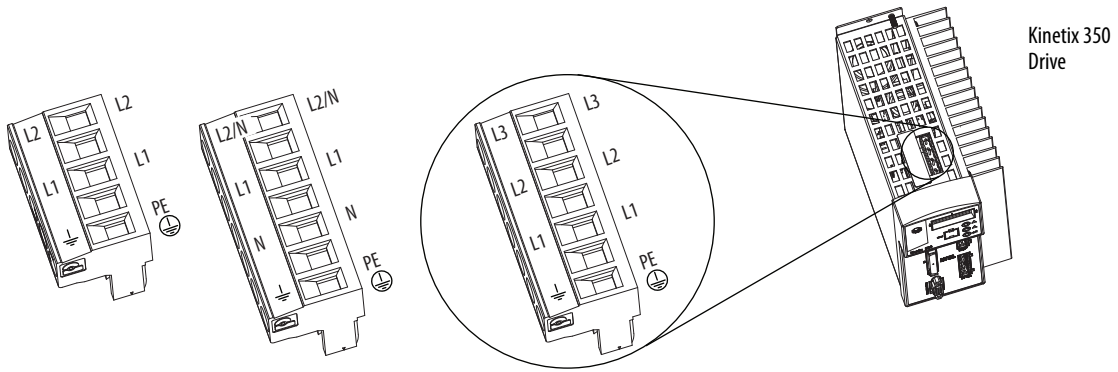

Table 26 - Input Power (IPD) Connector

Drive Cat. No.	Terminals			Recommended Wire Size mm ² (AWG)	Strip Length mm (in.)	Torque Value N·m (lb·in)
2097-V31PR0-LM 2097-V32PR0-LM 2097-V32PR2-LM 2097-V33PR1-LM 2097-V33PR3-LM 2097-V34PR3-LM 2097-V34PR5-LM 2097-V34PR6-LM	L3 L2 L1 PE ⁽¹⁾	L2/N L1 N PE ⁽²⁾	L2 L1 PE ⁽³⁾	2.5 (14)	7 (0.28)	0.5 (4.5)
2097-V32PR4-LM 2097-V33PR5-LM				4.0 (12)	7 (0.28)	0.5 (4.5)
2097-V31PR2-LM 2097-V33PR6-LM				6.0 (10)	7 (0.28)	0.56...0.79 (5.0...7.0)

(1) Applies to 2097-V33PRx-LM, and 2097-V34PRx-LM drive modules.

(2) Applies to 2097-V31PRx-LM drive modules.

(3) Applies to 2097-V32PRx-LM drive modules.

Wire the Motor Power (MP) Connector

Connections to the motor power (MP) connector include rotary motors and rotary motor driven actuators.

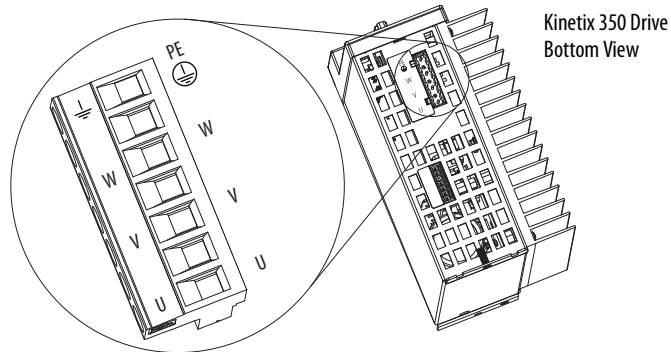

Table 27 - Motor Power (MP) Termination Specifications

Drive Cat. No.	Terminals	Recommended Wire Size mm ² (AWG)	Strip Length mm (in.)	Torque Value N·m (lb·in)
2097-V31PR0-LM 2097-V31PR2-LM 2097-V32PR0-LM 2097-V32PR2-LM 2097-V32PR4-LM 2097-V33PR1-LM 2097-V33PR3-LM 2097-V33PR5-LM 2097-V34PR3-LM 2097-V34PR5-LM 2097-V34PR6-LM	PE W V U	2.5 (14)	7 (0.28)	0.5 (4.5)
2097-V33PR6-LM		4.0 (12)		

Cable Shield Terminations

Factory-supplied motor power cables for MP-Series™ and TL-Series™ motors and actuator are shielded. The braided cable shield must terminate near the drive during installation. Remove small portion of the cable jacket to expose the shield braid and clamp the exposed shield to the panel.



ATTENTION: To avoid hazard of electrical shock, ensure shielded power cables are grounded at a minimum of one point for safety.

IMPORTANT For TL-Series™ motors, also connect the 152 mm (6.0 in.) termination wire to the closest earth ground.
See [Pigtail Terminations](#) on [page 65](#) for more information.

Pigtail Terminations

TL-Series motors have a short pigtail cable that connects to the motor, but is not shielded. The preferred method for grounding the TL-Series power cable on the motor side is to expose a section of the cable shield and clamp it directly to the machine frame. The motor power cable also has a 150 mm (6.0 in.) shield termination wire with a ring lug that connects to the closest earth ground. Use this method and the cable clamp. The termination wire can be extended to the full length of the motor pigtail if necessary, but it is best to connect the supplied wire directly to ground without lengthening.

Figure 36 - Pigtail Terminations

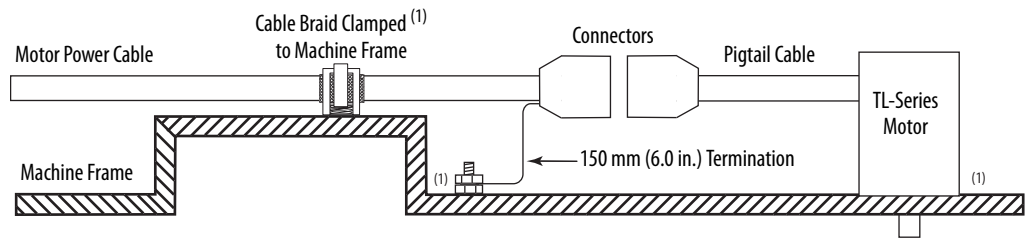

(1) Remove paint from machine frame to be sure of proper HF-bond between machine frame, motor case, shield clamp, and ground stud. Motor Power Cable Compatibility

Table 28 - Motor Power Cable Compatibility

Motor/Actuator	Connector	Motor/Actuator Cat. No.	Motor Power Cables (with Brake Wires)	Motor Power Cables (without Brake Wires)
MP-Series™ (Bulletin MPL)	Circular DIN	MPL-A/B15xxx-4xAA and MPL-A/B2xxx-4xAA	2090-XXNPMF-xxSxx (standard) 2090-CPBM4DF-xxAFxx (continuous-flex)	2090-CPWM4DF-xxAFxx (continuous-flex)
		MPL-A/B3xxx-7xAA, MPL-A/B4xxx-7xAA, and MPL-A/B45xxx-7xAA	2090-CPBM7DF-xxAAxx ⁽¹⁾ (standard) 2090-CPBM7DF-xxAFxx ⁽¹⁾ (continuous-flex)	2090-CPWM7DF-xxAAxx ⁽¹⁾ (standard) 2090-CPWM7DF-xxAFxx ⁽¹⁾ (continuous-flex)
MP-Series (Bulletin MPS)		MPS-A/Bxxxx	2090-XXNPMF-xxSxx (standard) 2090-CPBM4DF-xxAFxx (continuous-flex)	2090-CPWM4DF-xxAFxx (continuous-flex)
MP-Series (Bulletin MPAS)		MPAS-A/Bxxxx		
MP-Series (Bulletin MPAR)		MPAR-A/B1xxx and MPAR-A/B2xxx	2090-CPBM7DF-xxAAxx ⁽¹⁾ (standard) 2090-CPBM7DF-xxAFxx ⁽¹⁾ (continuous-flex)	2090-CPWM7DF-xxAAxx ⁽¹⁾ (standard) 2090-CPWM7DF-xxAFxx ⁽¹⁾ (continuous-flex)
MP-Series (Bulletin MPM)		MPM-A/Bxxxx		
MP-Series (Bulletin MPF)		MPF-A/Bxxxx		
MP-Series (Bulletin MPAI)		MPAI-A/Bxxxx		
TL-Series (Bulletin TLY)	Circular Plastic	TLY-Axxxx	2090-CPBM6DF-16AAxx (standard)	2090-CPWM6DF-16AAxx (standard)
TL-Series (Bulletin TLAR)		TLAR-Axxxx		

(1) You must remove the motor-side o-ring when you are using 2090-CPxM7DF-xxAxx cables.

This diagram shows an example of three-phase power wires for motors/actuators that have no brakes. Thermal switch wires are included in the feedback cable.

See [Kinetix 350 Drive/Rotary Motor Wiring Examples](#) that start on [page 134](#) for interconnect diagrams.

Figure 37 - Motor Power Terminations (Only Three-phase Wires)

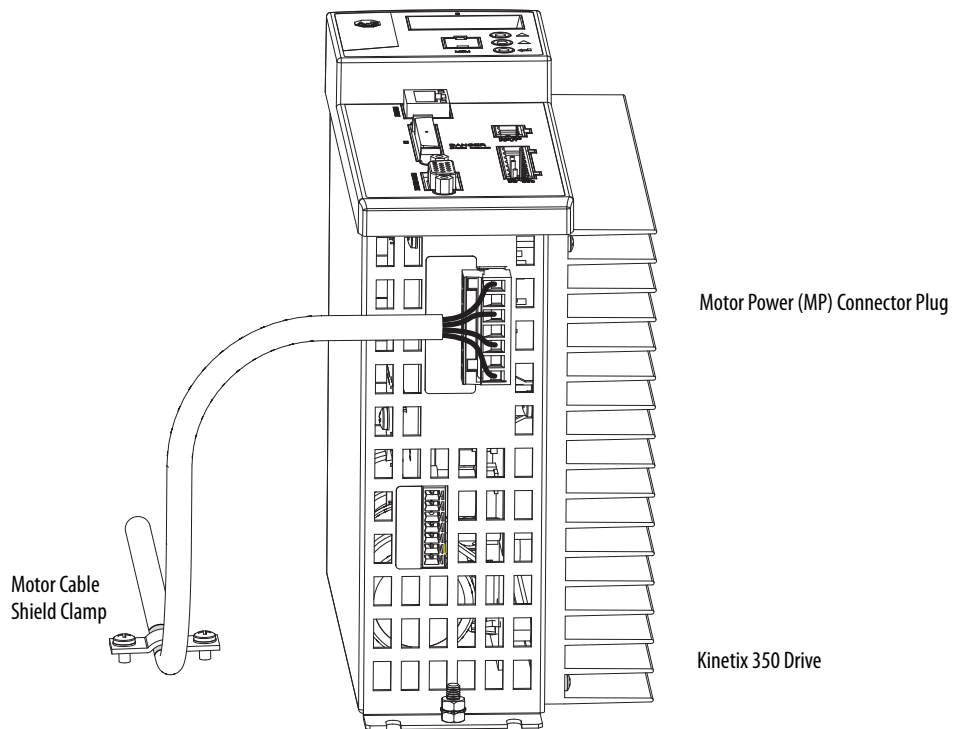

The cable shield clamp that is shown in [Figure 37](#) is mounted to the subpanel. Ground and secure the motor power cable in your system following instructions on [page 69](#).

This diagram shows an example of wiring with three-phase power wires and brake wires. The brake wires have a shield braid that is shown in [Figure 38](#) as gray, which folds back under the cable clamp before the conductors are attached to the motor brake circuit. Thermal switch wires are included in the feedback cable.

See [Kinetix 350 Drive/Rotary Motor Wiring Examples](#) that begin on [page 134](#) for interconnect diagrams.

Figure 38 - Motor Power Terminations (Three-phase and Brake Wires)

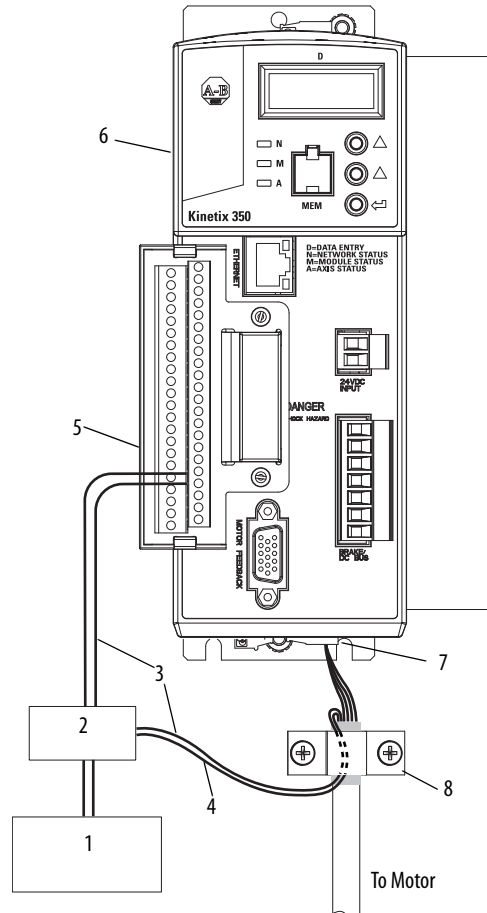

Item	Description	Item	Description
1 ⁽¹⁾	24V power supply	5	I/O (IOD) connector ⁽²⁾
2 ⁽¹⁾	Relay and diode assembly ⁽³⁾	6	2097-V3xPRx-LM Kinetix 350 drive
3	Minimize unshielded wires in brake circuit	7	Motor power (MP) connector
4	MP-Series cable brake wires	8	Cable clamp ⁽⁴⁾

- (1) User supplied. Size as required by motor brake, See [Motor Brake Currents](#) on [page 140](#).
- (2) Pins 43 and 44 are configured as MTR_ BRAKE+ and MTR_ BRAKE- Common respectively. Wire the output as sourcing and set brake engage and disengage times for motor selected. Motor brake is active on enable.
- (3) Diode 1N4004 (1 A @ 400V DC) or equivalent. See [Interconnect Diagram Notes](#) that being on [page 131](#).
- (4) Exposed shield under clamp and place within 50...75 mm (2...3 in.) of drive, see [page 69](#) for details.

Cable shield and lead preparation are provided with most Allen-Bradley® cable assemblies. Follow these guidelines if your motor power cable shield and wires require preparation.

Figure 39 - Cable Shield and Lead Preparation

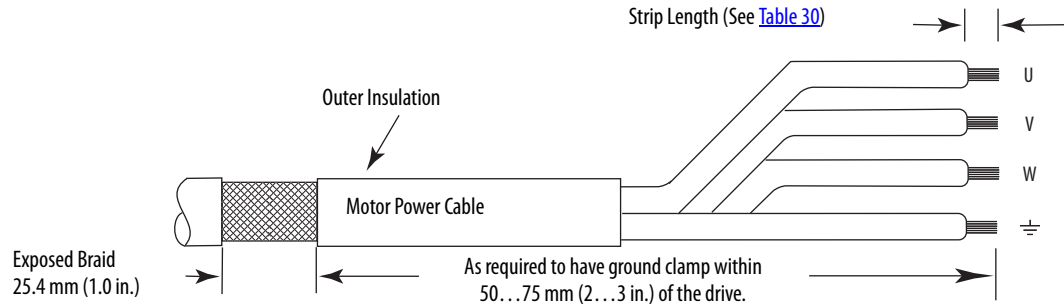

See [Shunt Resistor Wiring Example](#) that being on [page 133](#) for interconnect diagrams.

Table 29 - Motor Power (MP) Connector

MP-Series or TL-Series Servo Motor	Terminal
U / Brown	U
V / Black	V
W / Blue	W
⏏ Green/Yellow	⏏

Table 30 - Motor Power (MP) Termination Specifications

Drive Cat. No.	Terminals	Recommended Wire Size mm ² (AWG)	Strip Length mm (in.)	Torque Value N·m (lb·in)
2097-V31PRO-LM 2097-V31PR2-LM 2097-V32PRO-LM 2097-V32PR2-LM 2097-V32PR4-LM 2097-V33PR1-LM 2097-V33PR3-LM 2097-V33PR5-LM 2097-V34PR3-LM 2097-V34PR5-LM 2097-V34PR6-LM	PE W V U	2.5 (14)	7 (0.28)	0.5 (4.5)
2097-V33PR6-LM		4.0 (12)		

Apply the Motor Cable Shield Clamp

This procedure assumes that you have completed wiring your motor power (MP) connector and are ready to apply the cable shield clamp.

Follow these steps to apply the motor cable shield clamp.

1. Locate a suitable position for installing cable shield clamp within 50...75 mm (2...3 in.) of the drive.

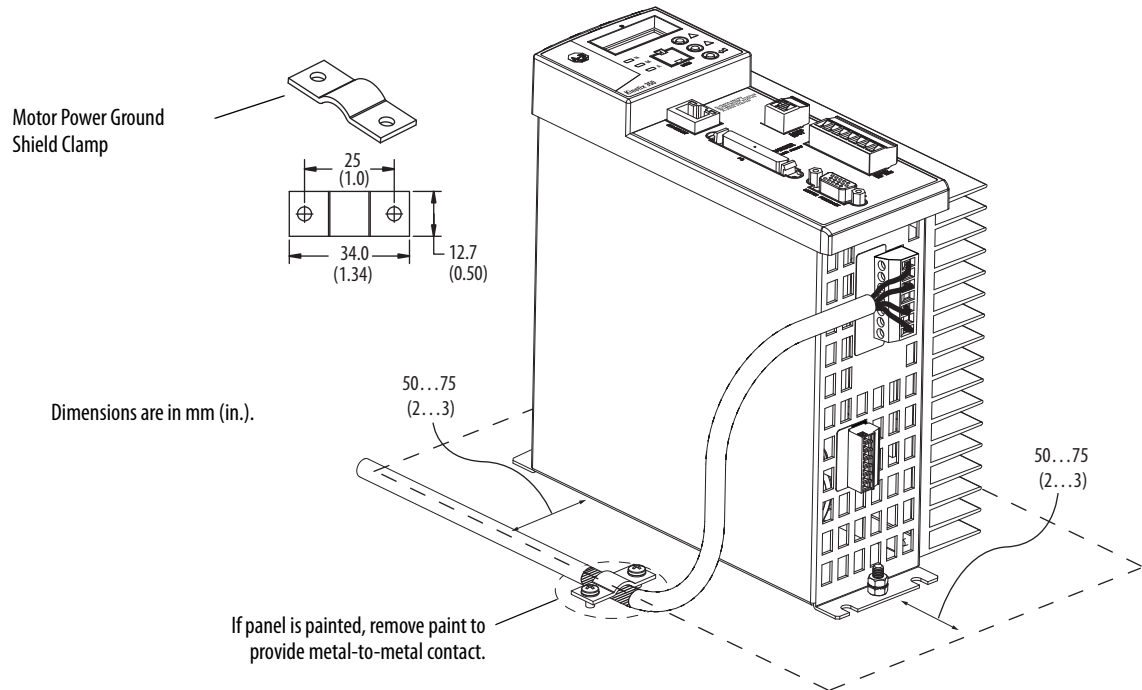

2. Lay out and drill holes for cable clamp.



ATTENTION: Plan the installation of your system so that you can cut, drill, tap, and weld with the system that is removed from the enclosure. Because the system is of the open type construction, be careful to keep any metal debris from falling into it. Metal debris or other foreign matter can become lodged in the circuitry, which can result in damage to components.

3. Locate the position on the motor power cable that comes under the clamp and remove about an inch of the cable jacket to expose the shield braid.
4. Position the exposed portion of the cable braid directly in line with the clamp.
5. Clamp the exposed shield to the panel by using the clamp and two #6-32 x 1 screws provided.
6. Repeat [step 1...step 5](#) for each Kinetix 350 drive you are installing.

Feedback and I/O Cable Connections

Factory made cables with premolded connectors are designed to minimize EMI and are recommended over hand-built cables to improve system performance. However, other options are available for building your own feedback and I/O cables.

Table 31 - Options for Connecting Motor Feedback and I/O

Connection Option	Cat. No.	Cable	By Using This Type of Cable
Premolded connectors	N/A	Motor feedback	See the table Table 32 for the premolded motor feedback cable available for your motor.
Low-profile connector	2090-K2CK-D15M	Motor feedback	See the table Table 32 for the flying-lead cable available for your motor.
I/O Terminal Block	2097-TB1	I/O interface	User-supplied flying-lead cable.

Table 32 - Motor Feedback Cables for Specific Motor/Feedback Combinations

Motor Cat. No.	Feedback Type	Feedback Cable		
		Premolded	Flying-lead	
MPL-A/B15xxx-V/Ex4xAA, MPL-A/B2xxx-V/Ex4xAA	High-resolution encoder	N/A	2090-XXNFMF-Sxx (standard) 2090-CFBM4DF-CDAFxx (continuous-flex)	
MPL-A/B15xxx-Hx4xAA, MPL-A/B2xxx-Hx4xAA	Incremental encoder	N/A	2090-XXNFMF-Sxx (standard) 2090-CFBM7DF-CDAFxx ⁽¹⁾ (continuous-flex)	
MPL-A/B3xxx-Hx7xAA, MPL-A/B4xxx-Hx7xAA, MPL-A/B45xxx-Hx7xAA				
MPL-A/B3xxx-M/Sx7xAA, MPL-A/B4xxx-M/Sx7xAA, MPL-A/B45xxx-M/Sx7xAA	High-resolution encoder	2090-CFBM7DD-CEAAxx ⁽¹⁾ (standard) 2090-CFBM7DD-CEAFxx ⁽¹⁾ (continuous-flex)	2090-CFBM7DF-CEAAxx ⁽¹⁾ (standard) 2090-CFBM7DF-CEAFxx ⁽¹⁾ (continuous-flex)	
MPM-A/Bxxxx-M/S	High-resolution encoder			
MPF-A/Bxxxx-M/S				
MPAR-A/B3xxxx				
MPAI-A/Bxxxx				
MPS-A/Bxxxx-M/S				
MPAS-A/Bxxxx-V/A	N/A			2090-XXNFMF-Sxx (standard) 2090-CFBM4DF-CDAFxx (continuous-flex)
MPAR-A/B1xxxx, MPAR-A/B2xxxx	High-resolution encoder			2090-CFBM6DD-CCAAxx (standard)
TLY-Axxxx-B				
TLAR-Axxxx				
TLY-Axxxx-H	Incremental encoder			

(1) You must remove the motor-side o-ring when you are using 2090-CPxM7DF-xxAxx cables.

Flying-lead Feedback Cable Pin-outs

Table 33 - 2090-XXNFMF-5xx or 2090-CFBMxDF-xxAxxx Feedback Cable

Connector Pin	High-resolution Feedback		Incremental Feedback	Drive MF Connector Pin
	9V Encoder	5V Encoder	5V Encoder	
1	Sin+	Sin+	AM+	1
2	Sin-	Sin-	AM-	2
3	Cos+	Cos+	BM+	3
4	Cos-	Cos-	BM-	4
5	Data+	Data+	IM+	5
6	Data-	Data-	IM-	10
9	Reserved	EPWR_5V	EPWR_5V	14
10	Reserved	ECOM	ECOM	6
11	EPWR_9V	Reserved	Reserved	7
12	ECOM	Reserved	Reserved	6
13	TS+	TS+	TS+	11
14	TS-	TS-	TS-	–
15	Reserved	Reserved	S1	12
16	Reserved	Reserved	S2	13
17	Reserved	Reserved	S3	8

Table 34 - 2090-CFBM6DF-CBAxx Feedback Cable

Connector Pin	High Resolution	Incremental Feedback	Drive MF Connector Pin
	TLY-Axxxx-B TLAR-Axxxx	TLY-Axxxx-H	
6	BAT+	Reserved	BAT+
9	Reserved	AM+	1
10		AM-	2
11		BM+	3
12		BM-	4
13	DATA+	IM+	5
14	DATA-	IM-	10
15	Reserved	S1	12
17		S2	13
19		S3	8
22	EPWR 5V	EPWR 5V	14
23	ECOM and BAT-	ECOM	6
24	Shield	Shield	Connector housing

Wiring the Feedback and I/O Connectors

These procedures assume that you have mounted your Kinetix 350 system, completed the power wiring, and are ready to connect motor feedback.

Wire the I/O Connector

Connect your I/O wires to the IOD connector by using the 2097-TB1 I/O Terminal Expansion Block. See the Kinetix 300 I/O Terminal Expansion Block Installation Instructions, publication [2097-IN005](#).

Figure 40 - Kinetix 350 Drive (IOD Connector and Terminal Block)

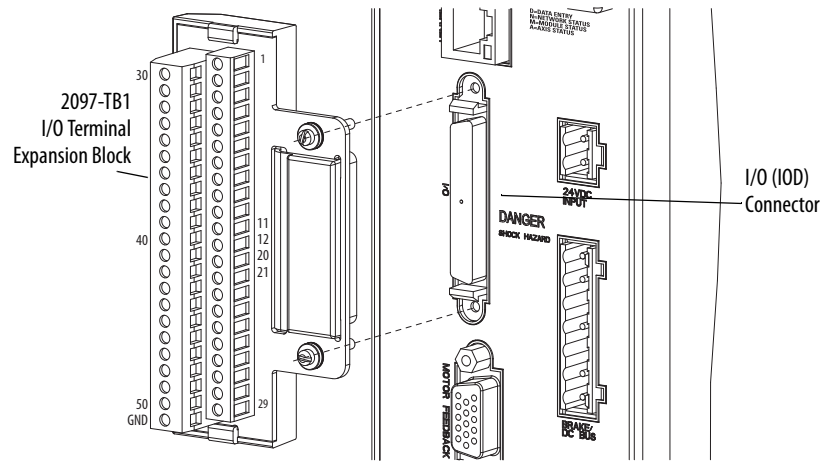

Wire the Low-profile Connector Kit

The 2090-K2CK-D15M low-profile connector kit is suitable for terminating flying-lead motor feedback cables. Use it with the Kinetix 350 drive and all motors with incremental or high-resolution feedback. It has a 15-pin, male, D-sub connector and is compatible with all Bulletin 2090 feedback cables.

TLY-Axxxx-B rotary motors and TLAR-Axxxx electric cylinders also require the 2090-DA-BAT2 battery to back up the high-resolution encoder.

Figure 41 - Kinetix 350 Drive (MF Connector)

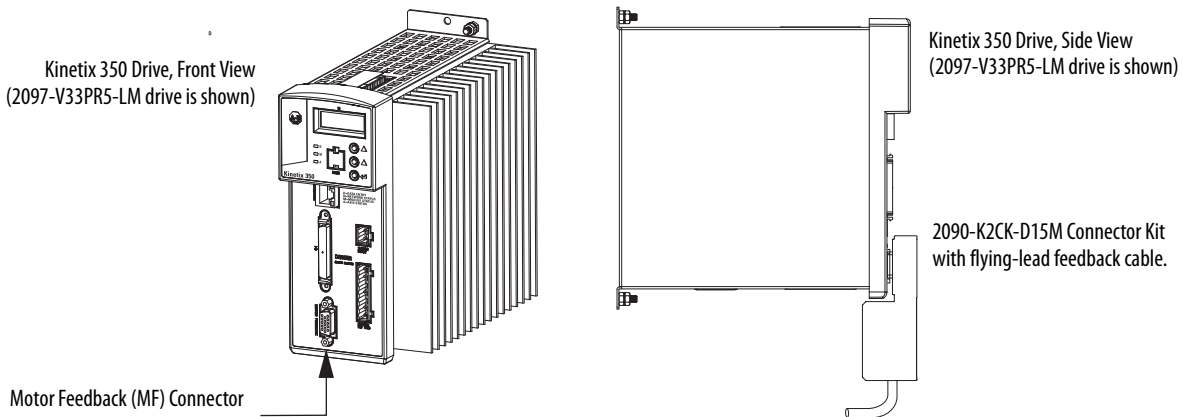

**Figure 42 - Wiring (15-pin) Flying-lead Feedback Cable Connections
2090-K2CK-D15M Connector Kit**

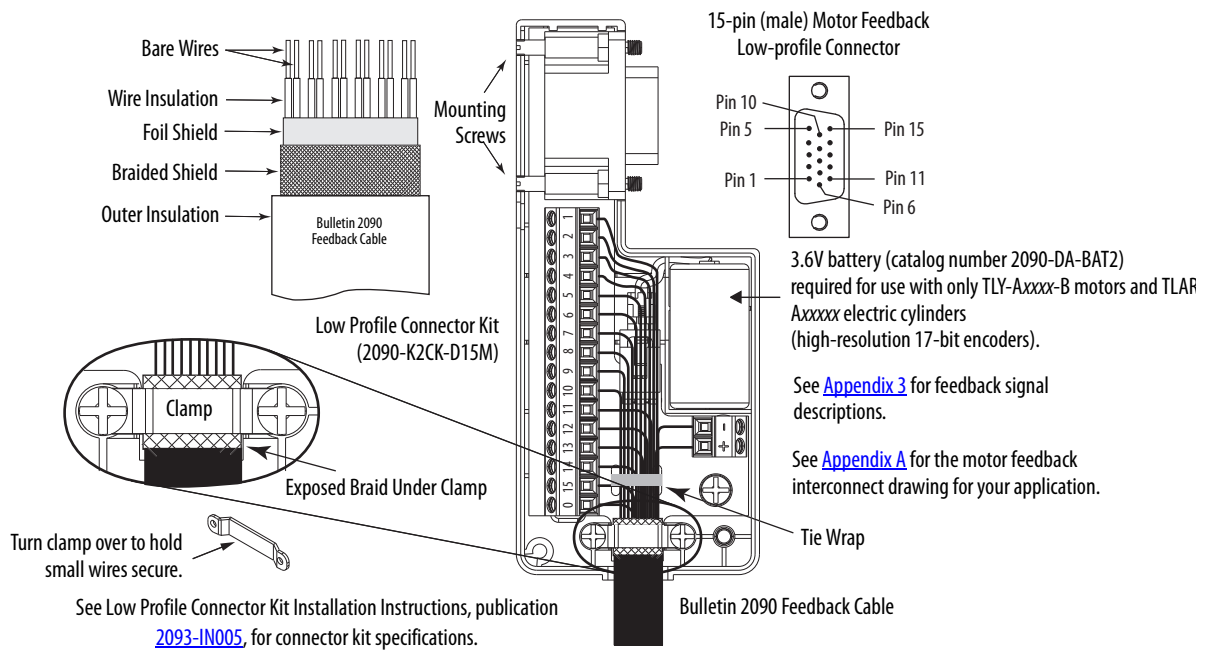

Shunt Resistor Connections

Follow these guidelines when wiring your 2097-Rx shunt resistor.

IMPORTANT When tightening screws to secure the wires, refer to the tables that begin on [page 60](#) for torque values.

IMPORTANT To improve system performance, run wires and cables in the wireways as established in [Chapter 2](#).

- See [Shunt Resistors](#) on [page 30](#) for noise zone considerations.
- See [Shunt Resistor Wiring Example](#) on [page 133](#).
- See the installation instructions that are provided with your Bulletin 2097 shunt resistor, publication [2097-IN002](#).

Figure 43 - Shunt/DC Bus (BC) Connector

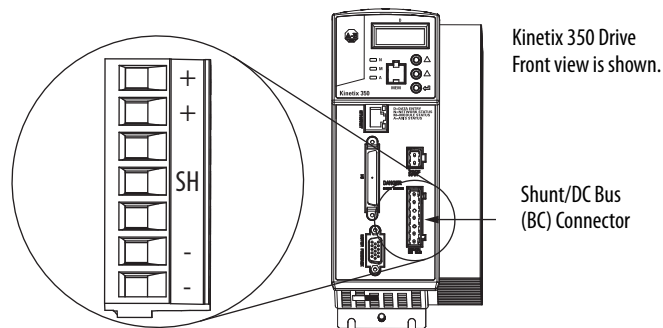

Table 35 - Shunt Resistor Power Wiring Requirements

Accessory	Description	Connects to Terminals	Recommended Wire Size mm ² (AWG)	Torque Value N•m (lb•in)
2097-Rx	Shunt resistor	+	2.5 (14)	0.5 (4.5)
		SH		

Ethernet Cable Connections

This guideline assumes that you have your Logix5000™ Ethernet/IP module and Kinetix 350 drive that is mounted and ready to connect the network cables.

IMPORTANT Connection to a larger network through an unmanaged switch without Internet Group Management Protocol Snooping could cause degradation to the larger network. Network switches without IEEE-1588 impacts the overall system accuracy. Your overall network topology, number of connected nodes and choice of EtherNet switch affects motion performance. For more detailed information on how to design your network, please consult the Converged Plantwide Ethernet (CPwE) Design and Implementation Guide, publication [ENET-TD001](#).

The EtherNet/IP network is connected by using the Port 1 connector. See [page 34](#) to locate the Ethernet connector on your Kinetix 350 drive. See

[Figure 44](#) to locate the connector on your Logix5000™ communication module.

Shielded Ethernet cable is available in lengths up to 78 m (256 ft). However, the total length of Ethernet cable connecting drive-to-drive, drive-to-controller, or drive-to-switch must not exceed 100 m (328 ft).

If the entire channel is constructed of stranded cable (no fixed cable), then this equation is for calculating maximum length:

$$\text{Maximum Length} = (113 - 2N) / y, \text{ meters}$$

where N = the number of connections in the channel

and y = the loss factor that is compared to fixed cable (typically 1.2...1.5).

Figure 44 - CompactLogix Ethernet Port Location

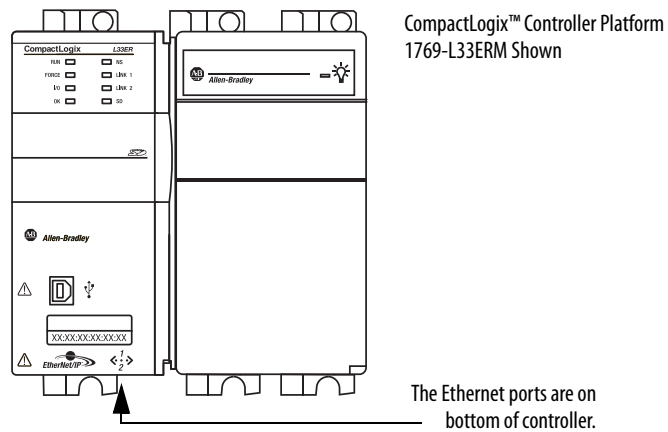

The Port 1 Ethernet connection is used for connecting to a Logix5000™ controller and to configure your Kinetix 350 drive.

Figure 45 - Ethernet Wiring Example - External Switch

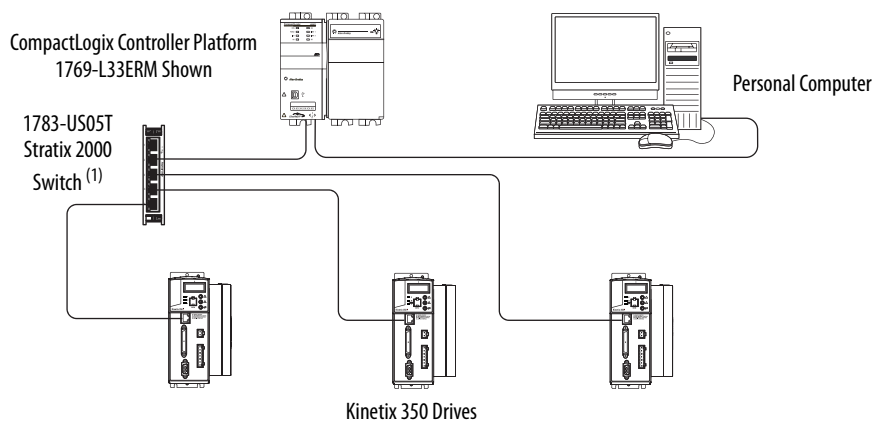

(1) See [Ethernet Cable Connections on page 74](#) for information on how to use an unmanaged switch in your application.





Notes:

Configure and Start up the Kinetix 350 Drive System

Topic	Page
Keypad Input	78
Configure the Kinetix 350 Drive Ethernet IP Address	81
Configure the Logix5000 EtherNet/IP Controller	84
Apply Power to the Kinetix 350 Drive	93
Test and Tune the Axes	94
Disable EnableInputChecking by Using a Logix Designer Message Instruction	100

TIP Before you begin make sure that you know the catalog number for the drive, the Logix5000™ controller, and the servo motor/actuator in your motion control application.

Keypad Input

The Kinetix® 350 drive is equipped with a diagnostic status indicator and three push buttons that are used to select displayed information and to edit a limited set of parameter values. Parameters can be scrolled by using  . To view a value, press . To return back to Scroll mode press .





After pressing  on editable parameters, the yellow status indicator D blinks indicating that the parameter value can be changed. Use   to change the value. Press  to store the new setting and return back to Scroll mode.

Table 36 - Status Display Information

Status Indicator	Description
StAt	Return to drive status.
Hx.xx	Hardware revision. For example, H2.00.
Fx.xx	Firmware revision. For example, F2.06.
Ht	Heatsink temperature. Heatsink temperature is shown in °C if greater than 40 °C. Otherwise 'LO (low) is displayed.
buS	Displays drive DC bus voltage.
Curr	Displays motor phase current (RMS). Shows current value if drive is enabled, otherwise shows DiS.
dHCP	Ethernet DHCP Configuration: 0='dHCP' is disabled; 1='dHCP' is enabled.
IP_1	Lets you modify the first octet of the IP address.
IP_2	Lets you modify the second octet of the IP address.
IP_3	Lets you modify the third octet of the IP address.
IP_4	Lets you modify the fourth octet of the IP address.
nEt1	Lets you modify the first octet of the netmask.
nEt2	Lets you modify the second octet of the netmask.
nEt3	Lets you modify the third octet of the netmask.
nEt4	Lets you modify the fourth octet of the netmask.
gat1	Lets you modify the first octet of the gateway.
gat2	Lets you modify the second octet of the gateway.
gat3	Lets you modify the third octet of the gateway.
gat4	Lets you modify the fourth octet of the gateway.

Status Indicators

The Kinetix 350 drive has four status indicators and a four-digit display on the top front panel as shown [Figure 46](#). These status indicators and the display are used to monitor the system status, activity, and troubleshoot faults.

Figure 46 - Front Panel Display

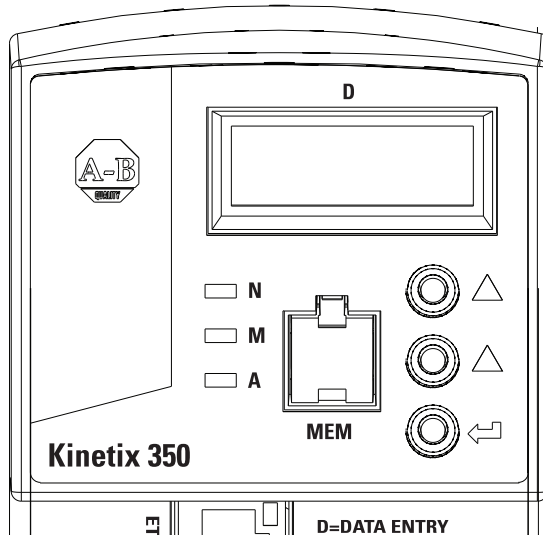

Table 37 - Status Indicators

Status Indicator	Function	Description
D	Data entry	Yellow status indicator flashes when changing.
N	Network state	Indicates the state of the Network. See Network State Status Indicator on page 80 . The bicolored status indicator shows red, green, or amber.
M	Module state	Indicates the state of the Network. See Module State Status Indicator on page 79 . The bicolored status indicator shows red, green, or amber.
A	Axis state	Indicates the state of the Network. See Axis State Status Indicator on page 80 . The bicolored status indicator shows red, green, or amber.

Table 38 - Module State Status Indicator

Status Indicator	State
Off	Power off
Flash red/green	Drive self-testing
Flashing green	Standby
Solid green	Operational
Flashing red	Major recoverable fault
Solid red	Major unrecoverable fault

Table 39 - Axis State Status Indicator

Status Indicator	State
Off	Off
Flash red/green	Self test
Off	Initialization - bus not up
Flashing green	Initialization - bus up
Off	Shutdown - bus not up
Flashing amber ⁽¹⁾	Shutdown - bus up
Off	Pre-charge - bus not up
Flashing amber ⁽¹⁾	Start inhibit
Flashing green ^{(1) (2)}	Stopped
Solid green ^{(1) (2)}	Stopping
	Starting
	Running
	Testing
Flashing red	Aborting
	Major faulted
Solid red	Aborting
	Major faulted

- (1) The axis and the drive define minor fault conditions. While a minor fault does not affect the drive status indicator, it does affect the axis status indicator. When a minor fault condition is detected, a normally solid-green status indicator indication changes to alternating red-green-red-green, a normally flashing green status indicator indication changes to alternating red-off-green-off, and a normally flashing amber indications changes to red-off-amber-off.
- (2) The drive also defines alarm conditions. When an alarm condition is detected, a normally solid-green status indicator indication changes to alternating amber-green-amber green while a normally flashing green status indicator indication changes to alternating amber-off-green-off.

Table 40 - Network State Status Indicator

Status Indicator	State
Steady off	Not powered, no IP address
Flashing green	No connections
Steady green	Connected
Flashing red	Connection time-out
Steady red	Duplicate IP
Flashing green and red	Self-test

Configure the Kinetix 350 Drive Ethernet IP Address

This section offers guidance on how to configure your Ethernet connection to the Kinetix 350 drive.

Ethernet Connection

Configuration, programming, and diagnostics of the Kinetix 350 drive are performed over the standard 10/100 Mbps Ethernet communication port by using the Studio 5000 Logix Designer® application.

The Kinetix 350 drive and your personal computer must be configured to operate on the same Ethernet network. The IP addresses of the Kinetix 350 drive, the personal computer, or both drive and personal computer can require configuring to enable Ethernet communication between the two devices.



IMPORTANT Any changes that are made to the Ethernet communication settings on the Kinetix 350 drive do not take effect until the drive is powered off and powered on again. Until the power is cycled, the drive continues to use its previous settings.

Kinetix 350 Drive Ethernet Port Configuration

The IP address of the Kinetix 350 drive is composed of four suboctets that are separated by three dots to conform to the Class C Subnet structure. Each suboctet can be configured with number from 1 to 254. As shipped from the factory the default IP address of a drive is 192.168.124.200.

There are two methods of changing the current IP address. An address can be assigned to the drive automatically (dynamic IP address) when the drive is connected to a DHCP (Dynamic Host Configuration Protocol) enabled server, or you can manually assign an IP address to the drive (static IP address). Both methods of configuring the drive's IP address are shown here.

Obtain the Kinetix 350 Drives' Current Ethernet Settings

The current Ethernet setting and IP address of the Kinetix 350 drive can be obtained from the drive display and keypad. Press  on the display and use   to access parameters IP_1, IP_2, IP_3, and IP_4. Each of these parameters contains one suboctet of the full IP address, for example, if the drive default (factory set) address parameters:

- IP_1 = 192
- IP_2 = 168
- IP_3 = 124
- IP_4 = 200





By accessing these four parameters, the full IP address on the drive can be obtained.

If parameters IP_1, IP_2, IP_3, and IP_4 all contain '----' rather than a numerical values it means that the drive has DHCP enabled and the DHCP server has yet to assign the drive its dynamic IP address. As soon as server assigns an IP address the drive displays the address in the IP_1, IP_2, IP_3, and IP_4 parameters. See Configure the IP Address Automatically (Dynamic Address) on [page 83](#).

Configure the IP Address Manually (Static Address)

When connecting directly from the Kinetix 350 drive to the personal computer without a server or when connecting to a private network, where all devices have static IP addresses, assign the IP address of the Kinetix 350 drive manually.

To assign the address manually, disable the DHCP mode. Do following the steps by using the drive keypad.

1. Press .
2. Use   to access parameter DHCP.
3. Check that this parameter is set to a value of 0.
4. If the DHCP parameter is set to 1, then use  and  to set to 0.
5. Cycle power to the drive.





The change takes effect.

When DHCP is disabled and the power is cycled to the drive, it reverts to its previous static IP address.

If you are connecting multiple drives to the personal computer, create unique IP address for each drive. Do it by using the keypad on each drive to change the IP_4 parameter. IP_4 is the only octet that can be changed via the keypad. IP_1, IP2, and IP_3 are read-only accessed this way. The drive power must be cycled for any changes to take effect.

Configure the IP Address Automatically (Dynamic Address)

When connecting a Kinetix 350 drive to a network domain with a DHCP enabled server, the IP address of the Kinetix 350 drive is assigned automatically. To have the address that is assigned automatically, the drive must have its DHCP mode enabled. Follow these steps by using the drive keypad and display.

1. Press .
2. Use the   to access parameter DHCP.
3. Check that this parameter is set to 1.
4. If the DHCP parameter is set to 0, use  and  to set the parameter to 1.
5. Cycle power to the drive to make this change take effect.

When the Kinetix 350 drive is waiting for an IP address to be assigned to it by the server it displays '----' in each of the four octet parameters (IP_1, IP_2, IP_3, and IP_4) on its display. Once the address is assigned by the server, it appears in these parameters. If this parameter continues to display '----', then it is likely that a connection between the drive and server has not been established, or the server is not DHCP enabled.

DHCP can be enabled through the Logix Designer application. If you choose to configure the drive by using a manual (static) IP address, you can switch over to an automatic (dynamic) address once configuration is complete. See [Obtain the Kinetix 350 Drives' Current Ethernet Settings](#) on [page 81](#) for information on how to enable the DHCP from within the Logix Designer application.

TIP A useful feature of the Logix Designer application and communication interface to the Kinetix 350 drive is the ability to assign the drive a name (text string). This name can then be used to discover the drive's IP address and is useful when the drive has its IP address that is assigned automatically by the server for easy connection.

Configure the Logix5000 EtherNet/IP Controller

This procedure assumes that you have wired your Kinetix 350 drive system and are using Logix Designer application version 21.00.00 or later.

For help using Logix Designer application as it applies to the configuration of the ControlLogix® EtherNet/IP controller, refer to [Additional Resources](#) on [page 9](#).

Configure the Logix5000 Controller

Follow these steps to configure the Logix5000 controller.

1. Apply power to your Logix5000 controller that contains the EtherNet/IP port and open your Studio 5000® environment.



2. Click New Project.

The New Project dialog box appears.

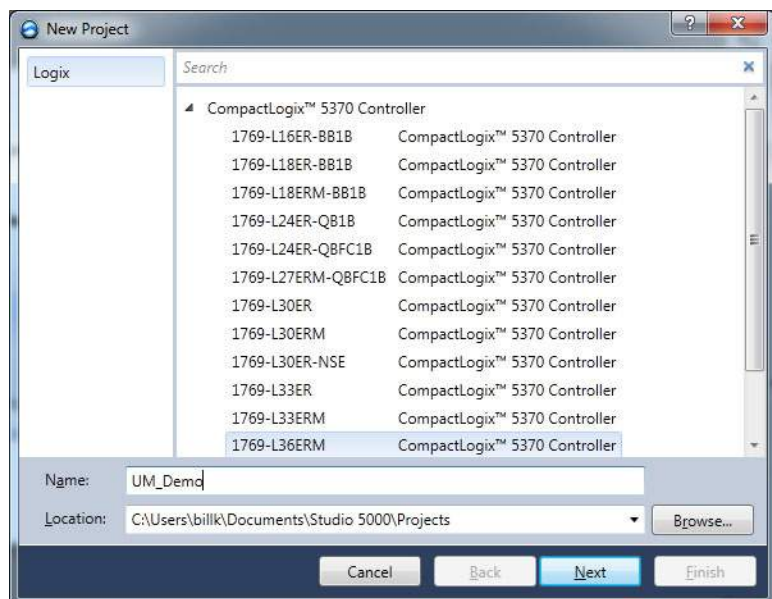

3. Select the controller that you are using for your project and click Next.

The New Controller dialog box appears.

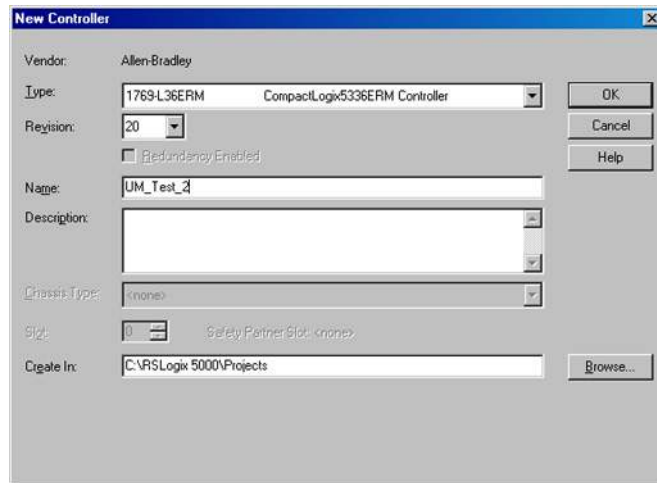

4. Configure the new controller.
 - a. From the Type pull-down menu, choose the controller type.
 - b. From the Revision pull-down menu, choose the revision.
 - c. Enter the file Name.
5. Click OK.
6. From the Edit menu, choose Controller Properties.

The Controller Properties dialog box appears.

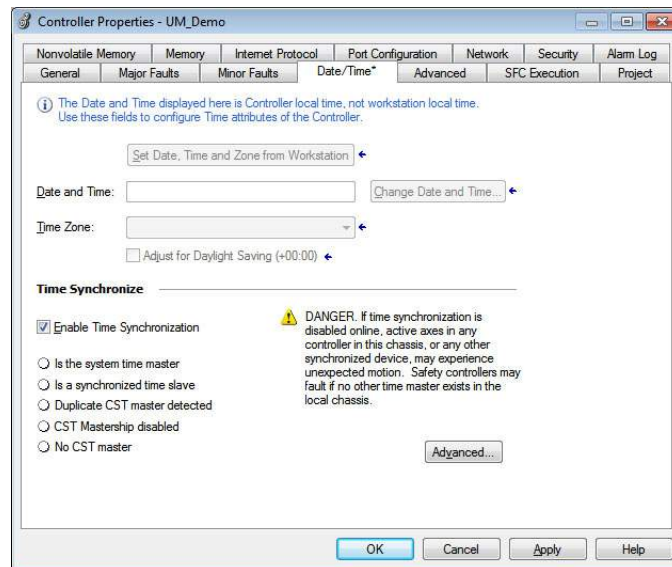

7. Click the Date/Time tab.
8. Check Enable Time Synchronization.

Enable Time Synchronization permits the controller to participate in the ControlLogix Time Synchronization. The controller also participates in an election in the Logix5000 system for the best GrandMaster clock.



ATTENTION: Do not change Grand Master clock when motion is active. Time must be universally understood by all Integrated Motion on the EtherNet/IP Motion Devices. A change in the wall clock of the Grand Master can introduce a clock skew between the Integrated Motion on the EtherNet/IP Motion devices. When clock skew is present the drive can go to sleep, jump, or move rapidly. Results can be a nuisance motion or motion that can damage equipment.

9. Click OK.

Configure the Kinetix 350 Drive

IMPORTANT To configure Kinetix 350 drive (catalog numbers 2097-V3xPRx-LM) you must be using RSLogix 5000® software, version 20 or later, or Logix Designer application.

Follow these steps to configure the Kinetix 350 drive.

1. Right-click the Logix5000 EtherNet/IP controller that you created and choose New Module.

The Select Module dialog box appears.

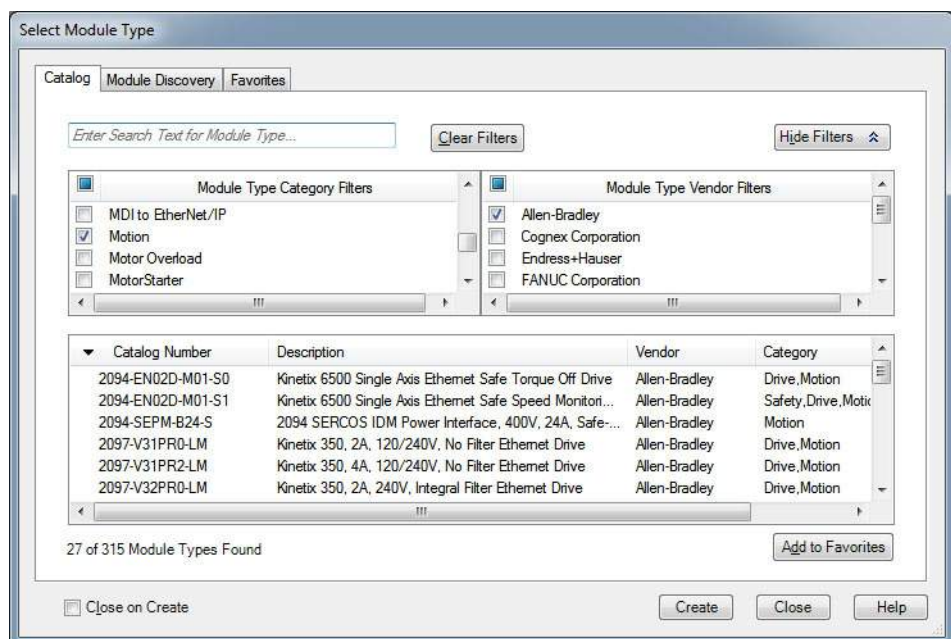

2. Clear the Module Type Category Filter and check the Motion category.

3. Select your 2097-V3xPRx-LM drive as appropriate for your actual hardware configuration and click Create.

The New Module dialog box appears.

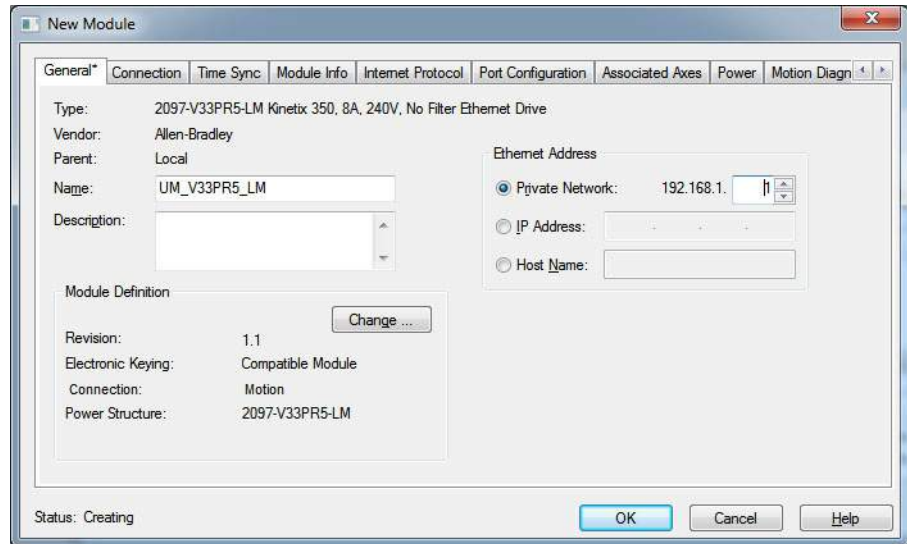

4. Configure the new drive.
 - a. Enter the drive Name.
 - b. Click an Ethernet Address option.

In this example, the Private Network address is selected.

- c. Enter the address of your EtherNet/IP drive.

In this example, the last octet of the address is 1. This octet must match the base node address of the drive.

5. Click Change in the Module Definition area.

The Module Definition dialog box appears.

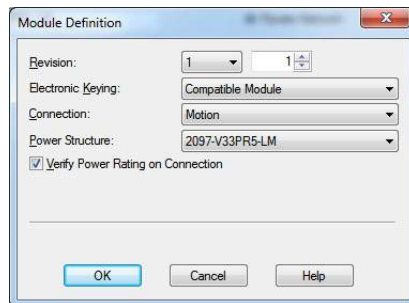

6. From the Power Structure pull-down menu, choose the Bulletin 2097 drive appropriate for your application.

In the example, the 2097-V3xPRx-LM module is chosen.

7. Click OK to close the Module Definition dialog box.
8. Click OK to close the Module Properties dialog box.

The 2097-V3xPRx-LM drive appears under the EtherNet/IP module in the I/O Configuration folder.

- Right-click the 2097-V3xPRx-LM module that you created and choose Properties.

The Module Properties dialog box appears.

- Click the Associated Axes tab.

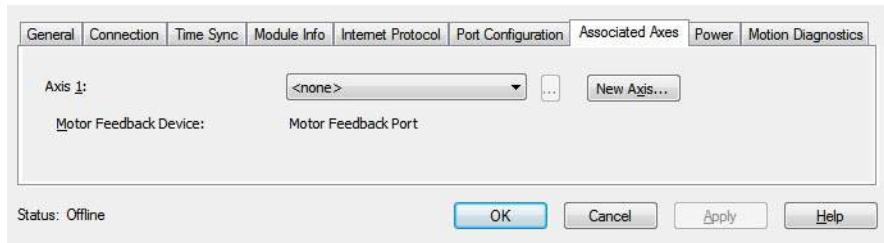

- Click New Axis.

The New Tag dialog box appears.

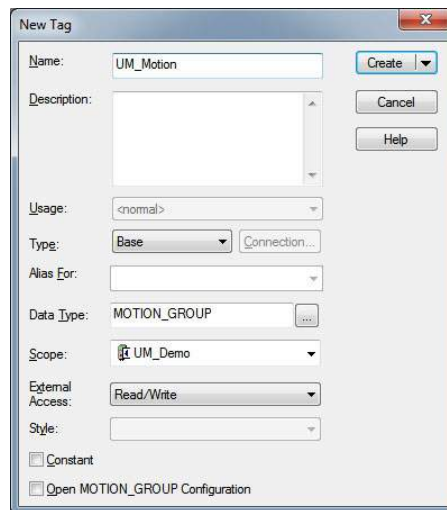

- Type the axis Name.

AXIS_CIP_DRIVE is the default Data Type.

- Click Create.

The new axis (Axis_1) appears under Motion Groups>Ungrouped Axes in the Controller Organizer and is assigned as Axis 1.

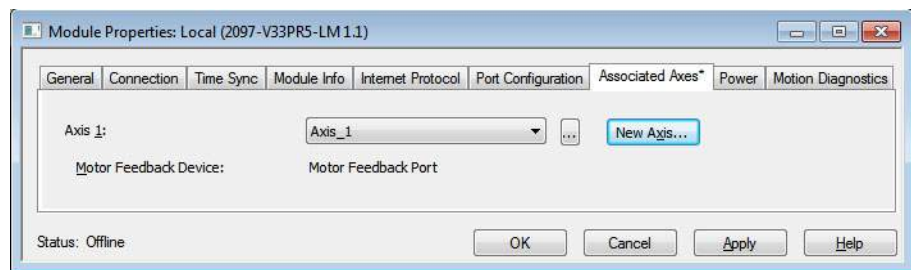

- Click Apply.

Configure the Motion Group

Follow these steps to configure the motion group.

1. Right-click Motion Groups in the Controller Organizer and choose New Motion Group.

The New Tag dialog box appears.

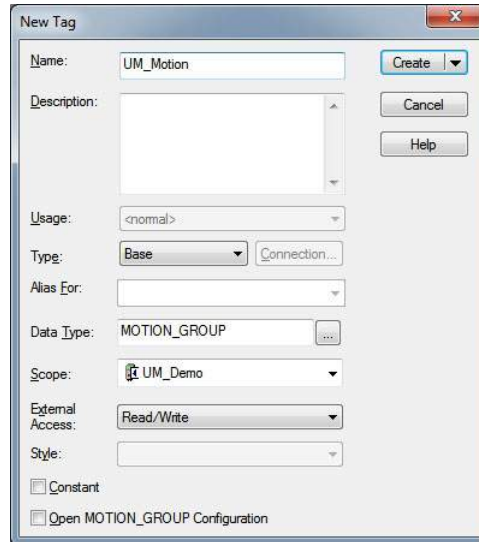

2. Type the new motion group Name.
3. Click Create.

The new motion group appears under the Motion Groups folder.

4. Right-click the new motion group and choose Properties.

The Motion Group Properties dialog box appears.

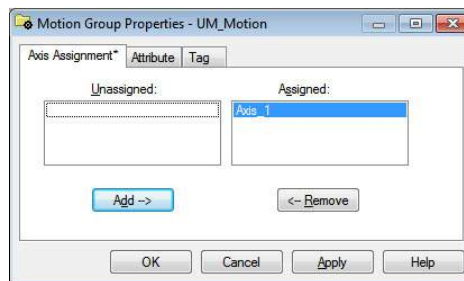

5. Click the Axis Assignment tab and move your axes (created earlier) from Unassigned to Assigned.
6. Click the Attribute tab and edit the default values as appropriate for your application.
7. Click OK.

Configure Axis Properties

To configure axis properties for your motor or actuator follow these instructions. If you are using an Integrated Motion Encoder on EtherNet/IP, catalog number 842E-CM for an axis refer to 842E-CM Integrated Motion Encoder on EtherNet/IP User Manual, publication [842E-UM002](#).

1. Right-click an axis in the Controller Organizer and choose Properties.
2. Click the Motor category.

The Motor Device Specification dialog box appears.

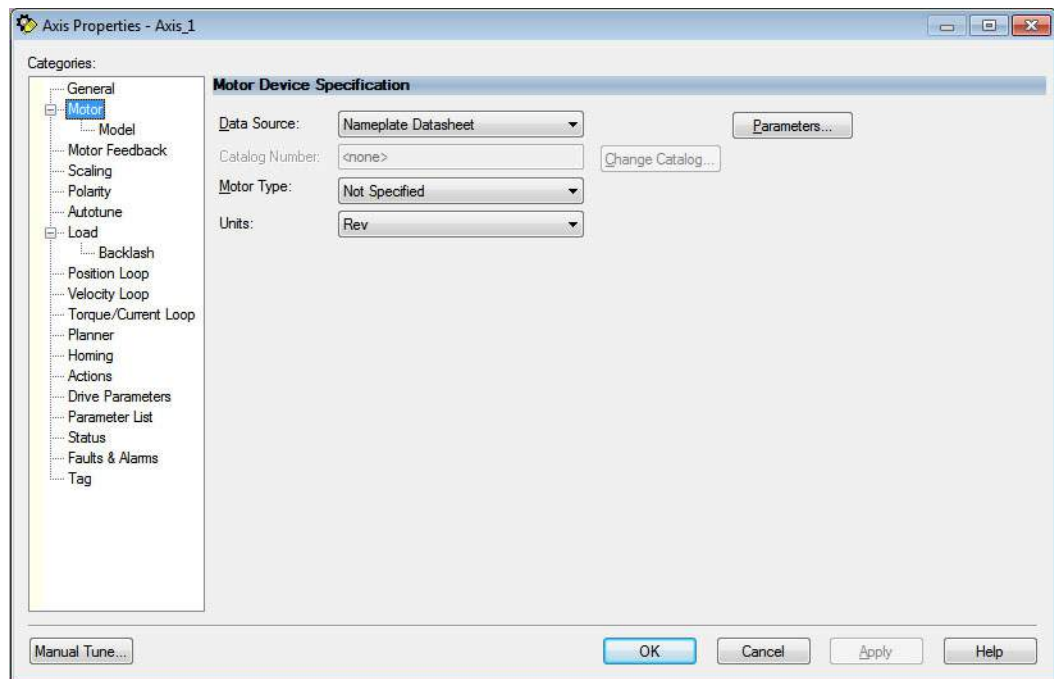

3. From the Data Source pull-down menu, choose Catalog Number.
4. Click Change Catalog.

The Change Catalog Number dialog box appears.

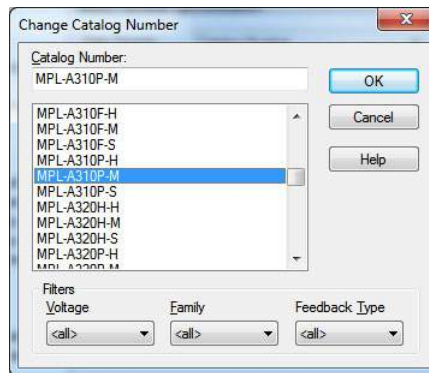

5. Select the motor catalog number appropriate for your application.
To verify the motor catalog number, refer to the motor name plate.
6. Click OK to close the Change Catalog Number dialog box.

7. Click Apply.
- Motor data specific to your motor appears in the Motor category.
8. Click the Scaling category and edit the default values as appropriate for your application.

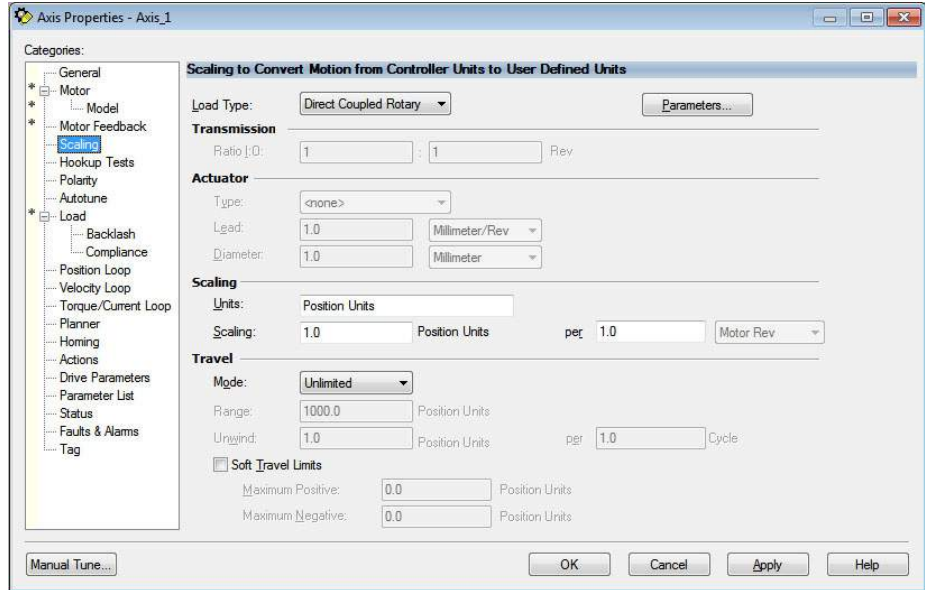

9. Click Apply, if you make changes.
10. Click Load category and edit the default values as appropriate for your application.

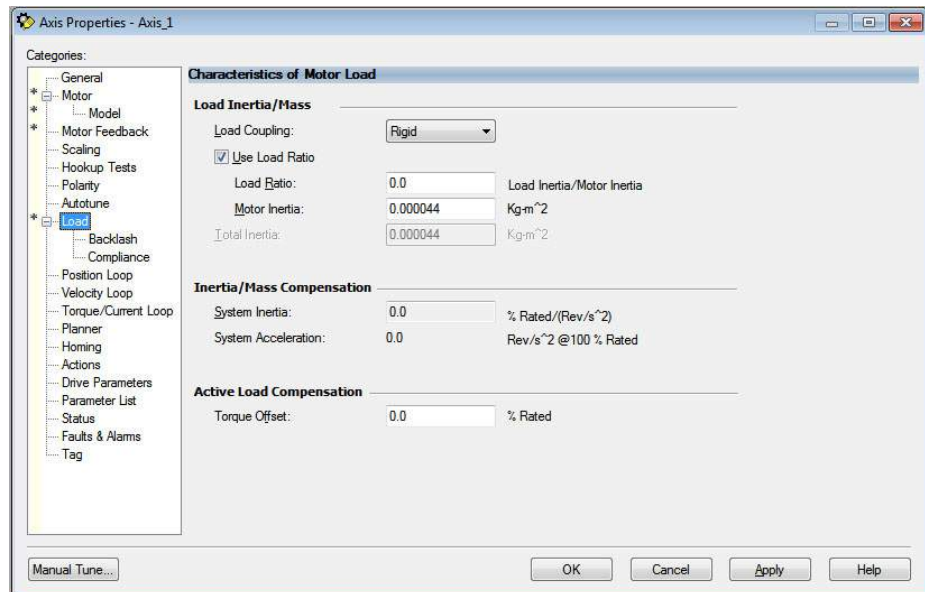

11. Click Apply, if you make changes.
12. Click Actions category.

The Actions to Take Upon Conditions dialog box appears.

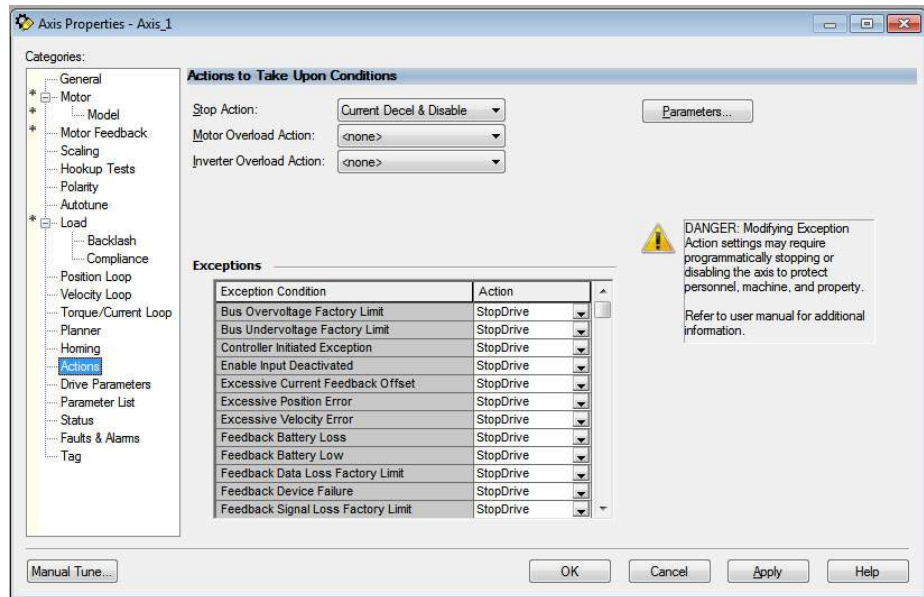

From this dialog box, you can program actions and change the action for exceptions (faults).

13. Click Parameters.

The Motion Axis Parameters dialog box appears.

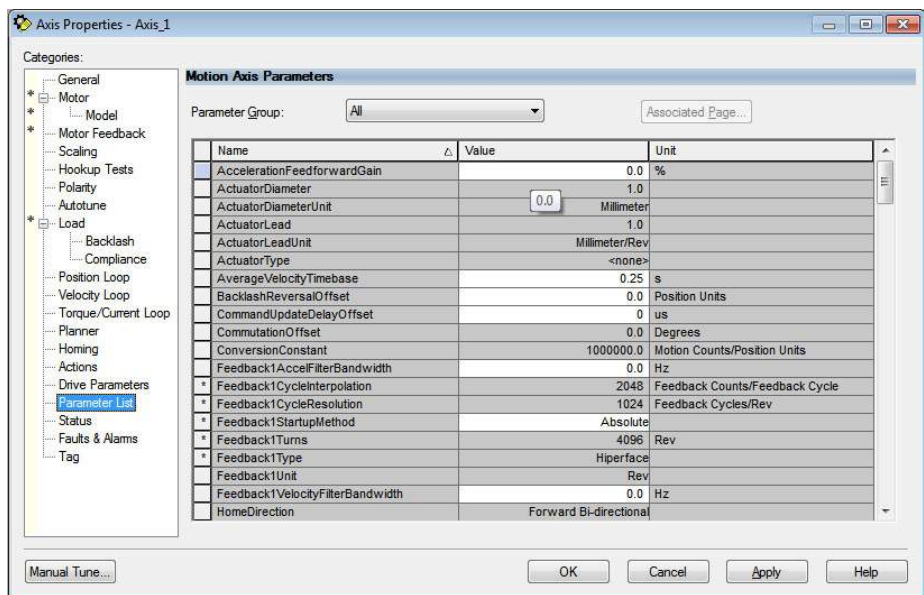

From this dialog box, you can set delay times for servo motors. For recommended motor brake delay times, refer to the Kinetix Motion Control Selection Guide, publication [KNX-SG001](#).

14. Click OK.
15. Verify your Logix5000 program and save the file.

Apply Power to the Kinetix 350 Drive

Download the Program

After completing the Logix5000 configuration, you must download your program to the Logix5000 processor.

This procedure assumes that you have wired and configured your Kinetix 350 drive system and your Ethernet/IP interface controller.



SHOCK HAZARD: To avoid hazard of electrical shock, perform all mounting and wiring of the Bulletin 2097 drive before you apply power. Once power is applied, connector terminals can have voltage present even when not in use.

Follow these steps to apply power to the Kinetix 350 drive system.

1. Disconnect the load to the motor.

The axis does not operate in position mode during the execution of this process. Therefore, the position of the axis cannot be guaranteed if the axis is connected to a vertical load, or the axis is connected to a stored mechanical energy.



ATTENTION: To avoid personal injury or damage to equipment, disconnect the load to the motor; including vertical loads. Make sure that each motor is free of all linkages when you initially apply power to the system.

2. Determine the source of the drive logic power.

If Your Logic Power	Then
Is from (24V DC) back-up power	Apply (24V DC) back-up power to the drive (BP connector).
Mains input power	Apply 120, 240, or 460V AC mains input power to the drive (IPD connector).

3. Apply 120, 240, or 460V AC mains input power to the Kinetix 350 drive IPD connector.
4. Observe the four-digit status indicator.

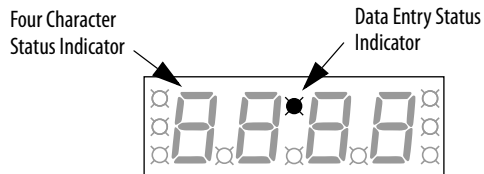

If the status indicator is	Then
-00-	Go to step 5
Blank	Return to main step 2

5.

If Your Logic Power	Then
Is from (24V DC) back-up power	Apply 120, 240, or 460V AC mains input power to the drive (IPD connector)
Mains input power	Go to step 5

6.

If drive ENABLE is	Then
Hard wired	Apply 24V DC
Not used	Disable enableInputChecking by using procedure on page 100

7. Observe the status indicator on the front of the Kinetix 350 drive.

Status Indicator	Condition	Status	Do This
Module	Steady green	Operational condition	Observe the Axis, status indicator page 80
	Steady or flashing red	Drive is faulted	Go to Module State Status Indicator on page 79
Axis	Steady green or amber, flashing	Operational condition	Observe the Network, status indicator page 80
	Steady or flashing red	Axis is faulted	Go to Axis State Status Indicator on page 80
Network	Steady green	Communication is ready	Go to Test and Tune the Axes on page 94
	Any state other than steady green	Communication error	Go to Network State Status Indicator on page 80

Test and Tune the Axes

This procedure assumes that you have configured your Kinetix 350 drive, your ControlLogix EtherNet/IP controller, and applied power to the system. See Motion System Tuning Application Techniques, publication [MOTION-AT005](#) for more information on Kinetix servo drive tuning.

IMPORTANT Before proceeding with testing and tuning your axes, verify that the drive status indicators are operating as described in [Status Indicators on page 119](#)

For help using Logix Designer Application as it applies to testing and tuning your axes with ControlLogix EtherNet/IP controller, refer to [Additional Resources on page 9](#).

Test the Axes

Follow these steps to test the axes.

1. Verify that the load was removed from each axis.
2. Right-click an axis in your Motion Group folder and choose Properties.

The Axis Properties dialog box appears.

3. Click Hookup Tests category.

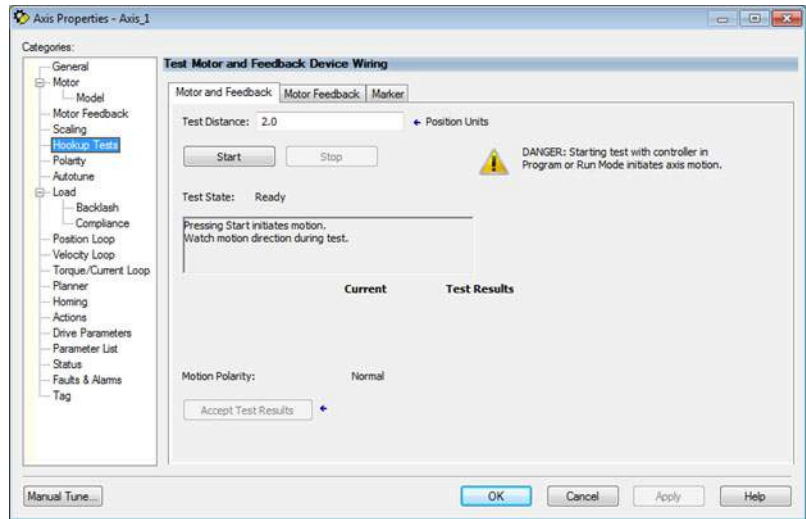

4. Type 2.0 as the number of revolutions for the test or another number more appropriate for your application.

This Test	Performs this Test
Marker	Verifies marker detection capability as you rotate the motor shaft.
Motor Feedback	Verifies that feedback connections are wired correctly as you rotate the motor shaft.
Motor and Feedback	Verifies that motor power and feedback connections are wired correctly as you command the motor to rotate.

5.

If drive ENABLE is	Then
Hard wired	Apply 24V DC
Not used	Disable enableInputChecking by using procedure on page 100



ATTENTION: To avoid personal injury or damage to equipment, apply only 24V ENABLE signal to the axis you are testing.

6. Click the desired tab (Marker/Motor Feedback/Motor and Feedback).
In this example, the Motor and Feedback test is chosen.

7. Click Start.

The RSLogix 5000 - Motor and Feedback Test dialog box appears. The Test State is Executing.

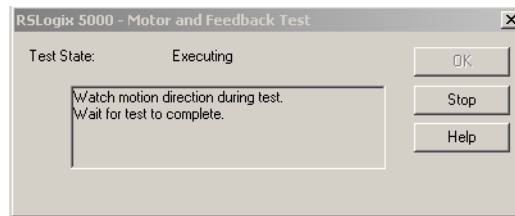

When the test completes successfully, the Test State changes from Executing to Passed.

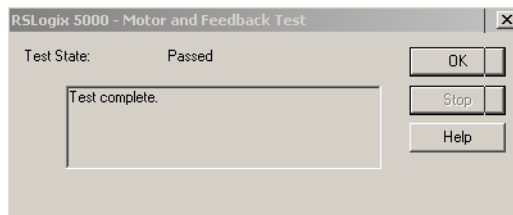

8. Click OK.

This dialog box appears, to confirm that the direction was correct.

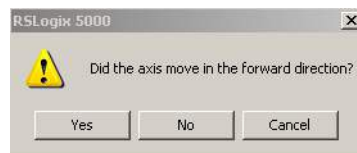

9. Click Yes.

If the test fails, this dialog box appears.



- a. Click OK.
- b. Verify that the Axis status indicator turned solid green during the test.
- c. Verify that the drive ENABLE signal is applied to the axis you are testing or that the enableInputChecking attribute is set to zero.
- d. Verify the unit values that are entered in the Scaling category.
- e. Return to main [step 6](#) and run the test again.

Tune the Axes

The following is a basic procedure for simple systems. If you have a complicated system, see Integrated Motion on the EtherNet/IP Network: Configuration and Startup, publication [MOTION-UM003](#) and Motion System Tuning Application Techniques, publication [MOTION-AT005](#).

Follow these steps to tune the axes.

1. Verify that the load is still removed from the axis being tuned.



ATTENTION: To reduce the possibility of unpredictable motor response, tune your motor with the load removed first, including vertical loads, then reattach the load and perform the tuning procedure again to provide an accurate operational response

2. Click Autotune category.

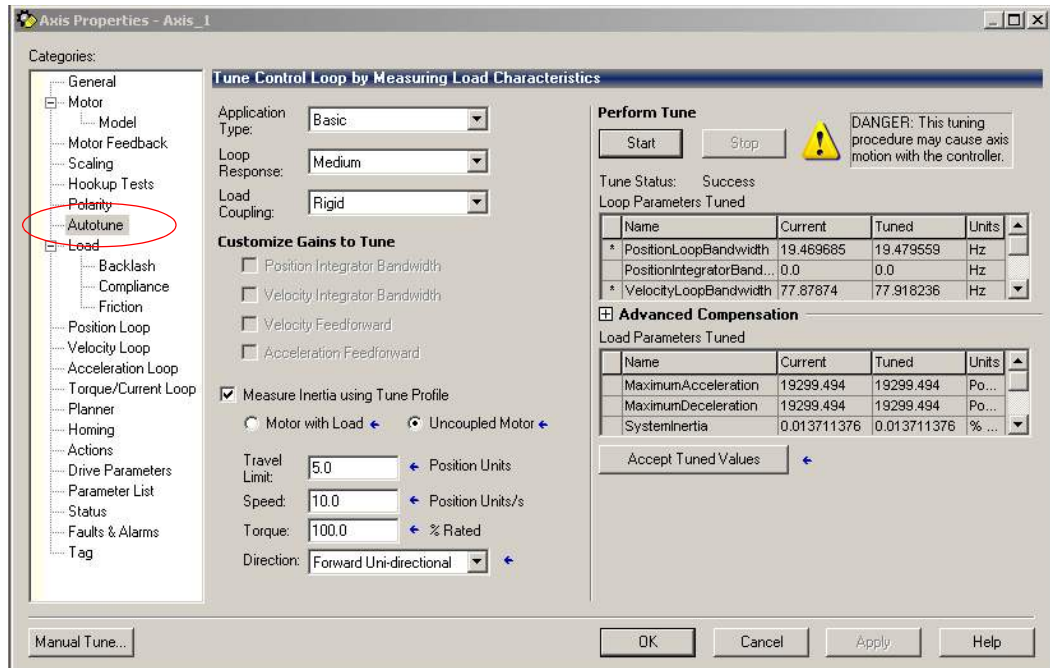

3. Type values for Travel Limit and Speed.

In this example, Travel Limit = 5 and Speed = 10. The actual value of programmed units depends on your application.

4. From the Direction pull-down menu, choose a setting appropriate for your application.

Forward Uni-directional is default.

5. Edit other fields as appropriate for your application and click Apply.

6.

If drive ENABLE is	Then
Hard wired	Apply 24V DC
Not used	Disable enableInputChecking by using procedure on page 100



ATTENTION: To avoid personal injury or damage to equipment, apply only 24V ENABLE signal to the axis you are testing.

7. Click Start.

The RSLogix - Autotune dialog box appears. When the test completes, the Test State changes from Executing to Success.

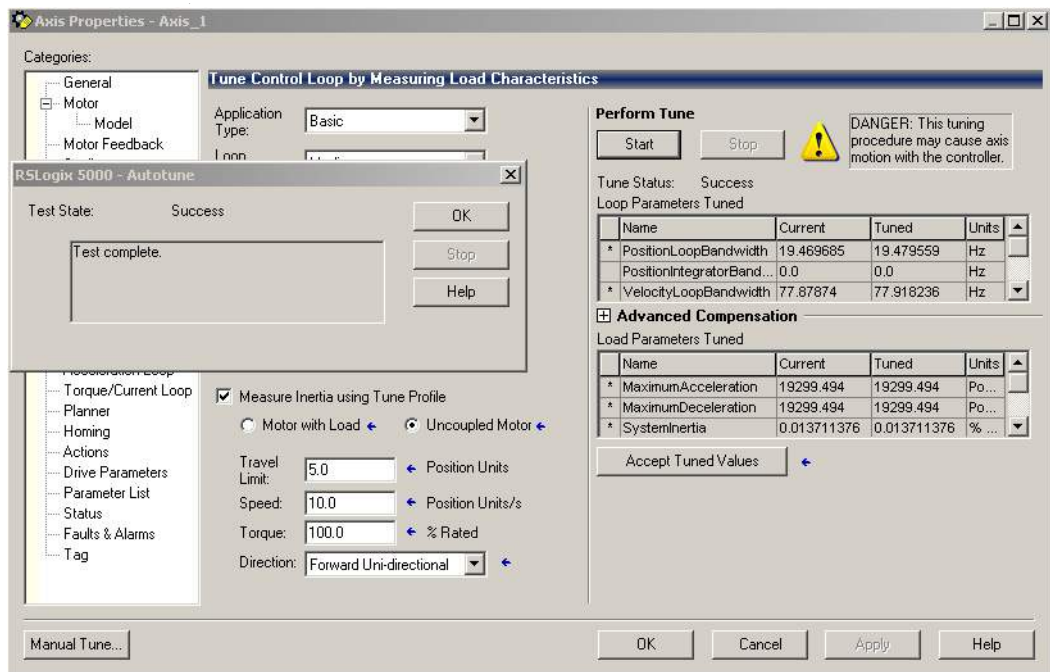

Tuned values populate the Loop and Load parameter tables. Actual bandwidth values (Hz) depend on your application and can require adjustment once motor and load are connected.

At this point, you can compare existing and tuned values for your gains and inertias with the prospective tune values.

8. Accept the new values and apply them to the controller.

Now you can run the system with the new gain set and evaluate performance. You can improve the performance by adjusting application type, loop response, and/or load coupling selections.

TIP If your application requires stricter performance, you can further improve performance with manual tuning.

9. Click OK to close the RSLogix 5000 - Autotune dialog box.

10. Click OK to close the Axis Properties dialog box.

11. If the test fails, this dialog box appears.



- a. Click OK.
 - b. Make motor velocity adjustments.
 - c. See the appropriate Logix5000 motion module user manual for more information.
 - d. Return to [step 7](#) and run the test again.
12. Repeat [Test and Tune the Axes](#) for each axis.

Disable EnableInputChecking by Using a Logix Designer Message Instruction

This procedure sends a Logix5000 message to disable the EnableInputChecking attribute in the Kinetix 350 drive.

1. From the Controller Organizer, choose Tasks>MainTask>MainProgram>MainRoutine.
2. Create an MSG instruction rung as shown.

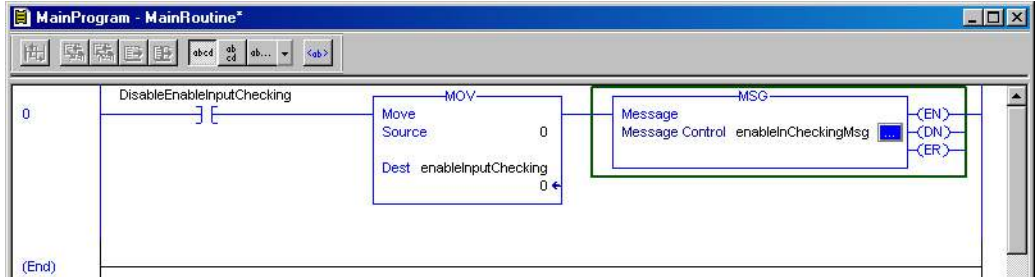

3. Set the values in the Message Configuration as shown.

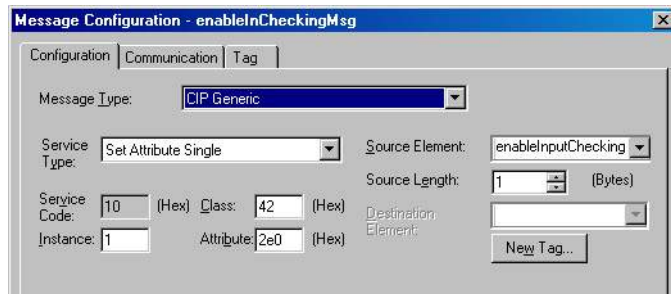

4. Click the Communications tab and browse to the drive tag, in this case K350, as shown.

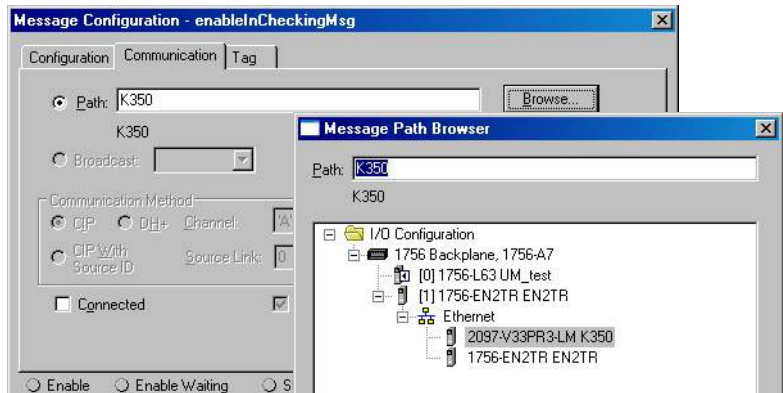

5. When the program is in Run mode, trigger the rung to run the instruction.

The drive does not check the enable input signal on IOD-29 Enable to IOD-26 Common. This MSG instruction is executed only once as it is a persistent type instruction and gets saved to the drive Non-volatile Memory. To re-enable the enable input signal checking on IOD-29 Enable to IOD-26 Common, change the Source Element register, EnableInputChecking from 0 to 1 and trigger the run again.

Kinetix 350 Drive Safe Torque-off Feature

Topic	Page
Certification	101
Description of Operation	102
PFD and PFH Definitions	103
PFD and PFH Data	103
Safe Torque-off Connector Data	104
Wiring Your Safe Torque-off Circuit	105
Kinetix 350 Drive Safe Torque-off Feature	107
Kinetix 350 Drive Safe Torque-off Wiring Diagrams	108
Safe Torque-off Signal Specifications	109

Certification

The safe torque-off circuit is type-approved and certified for use in safety applications up to and including ISO 13849-1 performance level d (PLd) safety category 3.

The TÜV Rheinland group has approved the Kinetix® 350 drives for use in safety-related applications up to ISO 13849-1 performance level d (PLd) safety category 3, in which the de-energized state is considered to be the safe state. All examples that are related to I/O included in this manual are based on achieving de-energization as the safe state for typical machine safety systems.

Important Safety Considerations

You are responsible for the following:

- Validation of any sensors or actuators that are connected to the drive system
- Completing a machine-level risk assessment
- Certification of the machine to the desired EN ISO 13849-1 performance level
- Project management and proof testing
- Programming the application software and the device configurations in accordance with the information in this safety reference manual and the drive product manual

Safety Category 3 Requirements

Safety-related parts are designed with these attributes:

- A single fault in any of these parts does not lead to the loss of the safety function
- A single fault is detected whenever reasonably practicable
- Accumulation of undetected faults can lead to the loss of the safety function.

Stop Category Definition

Stop category 0 is achieved with immediate removal of power to the actuator.

IMPORTANT In the event of drive or control failure, the most likely stop category is category 0. When designing the machine application, consider timing and distance for a coast to stop. For more information regarding stop categories, refer to EN 60204-1.

Performance Level and Safety Integrity Level (SIL) CL2

For safety-related control systems, Performance Level (PL), according to EN ISO 13849-1, and SIL levels, according to EN 61508 and EN 62061, include a rating of the systems ability to perform its safety functions. All safety-related components of the control system must be included in both a risk assessment and the determination of the achieved levels.

See the EN ISO 13849-1, EN 61508, and EN 62061 standards for complete information on requirements for PL and SIL determination.

Description of Operation

The safe torque-off feature provides a method, with sufficiently low probability of failure on demand, to force the power-transistor control signals to a disabled state. When disabled, or any time power is removed from the safety enable inputs, all drives output-power transistors are released from the ON state, effectively removing motive power generated by the drive. This results in a condition where the motor is in a coasting condition (stop category 0). Disabling the power transistor output does not provide mechanical isolation of the electrical output, which can be required for some applications.

Under normal drive operation, the safe torque-off switches are energized. If either of the safety enable inputs are de-energized, the gate control circuit is disabled. To meet EN ISO 13849-1 (PLd) both safety channels must be used and monitored.



ATTENTION: Permanent magnet motors can, if there are of two simultaneous faults in the IGBT circuit, result in a rotation of up to 180 electrical degrees.

Troubleshoot the Safe Torque-off Function



ATTENTION: When the safe torque-off function is activated, the drive posts a Start Inhibit (Sc05). After troubleshooting, a proof test safety function must be performed to verify correct operation.

PFD and PFH Definitions

Safety-related systems can be classified as operating in either a Low Demand mode, or in a High Demand/Continuous mode:

- Low Demand mode: where the frequency of demands for operation that is made on a safety-related system is no greater than one per year or no greater than twice the proof-test frequency.
- High Demand/Continuous mode: where the frequency of demands for operation that is made on a safety-related system is greater than once per year or greater than twice the proof test interval.

The SIL value for a low demand safety-related system is directly related to order-of-magnitude ranges of its average probability of failure to perform its safety function on demand satisfactorily or, simply, average probability of failure on demand (PFD). The SIL value for a High Demand/Continuous mode safety-related system is directly related to the probability of a dangerous failure occurring per hour (PFH).

PFD and PFH Data

These PFD and PFH calculations are based on the equations from EN 61508 and show worst-case values.

This table provides data for a 20-year proof test interval and demonstrates the worst-case effect of various configuration changes on the data.

Table 41 - PFD and PFH for 20-year Proof Test Interval

Attribute	Value
PFH [1e-9]	5.9
PFD [1e-3]	1.0

Safe Torque-off Connector Data

This section provides safe torque-off (STO) connector and header information for the Kinetix 350 drive safe torque-off.

STO Connector Pinouts

Headers extend the STO connector signals for use in wiring or to defeat (not use) the safe torque-off function.

Figure 47 - 6-pin Safe Torque-off (STO) Connector

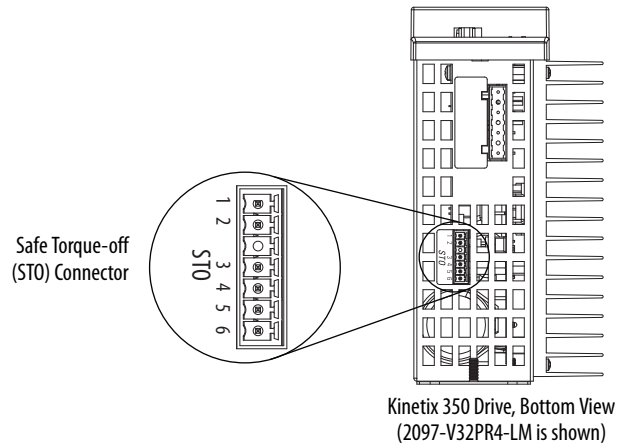

STO Pin	Description	Signal
1	+24V DC output from the drive	+24V DC control
2	+24V DC output common	Control COM
3	Safety status	Safety Status
4	Safety input 1 (+24V DC to enable)	Safety Input 1
5	Safety common	Safety COM
6	Safety input 2 (+24V DC to enable)	Safety Input 2

Wiring Your Safe Torque-off Circuit

This section provides guidelines for wiring your Kinetix 350 safe torque-off drive connections.

European Union Directives

If this product is installed within the European Union or EEC regions and has the CE mark, the following regulations apply.

For more information on the concept of electrical noise reduction, refer to System Design for Control of Electrical Noise Reference Manual, publication [GMC-RM001](#).

EMC Directive

This unit is tested to meet Council Directive 2004/108/EC Electromagnetic Compatibility (EMC) by using these standards, in whole or in part:

- EN 61800-3 - Adjustable Speed Electrical Power Drive Systems, Part 3 - EMC Product Standard including specific test methods
- EN 61000-6-4 EMC - Emission Standard, Part 2 - Industrial Environment
- EN 61000-6-2 EMC - Immunity Standard, Part 2 - Industrial Environment

The product that is described in this manual is intended for use in an industrial environment.

CE Conformity

Conformity with the Low Voltage Directive and Electromagnetic Compatibility (EMC) Directive is demonstrated by using harmonized European Norm (EN) standards that are published in the Official Journal of the European Communities. The safe torque-off circuit complies with the EN standards when installed according to instructions found in this manual.

CE Declarations of Conformity are available online at:
<http://www.rockwellautomation.com/products/certification/ce>.

Low Voltage Directive

These units are tested to meet Council Directive 2006/95/EC Low Voltage Directive. The EN 60204-1 Safety of Machinery-Electrical Equipment of Machines, Part 1-Specification for General Requirements standard applies in whole or in part. Additionally, the standard EN 50178 Electronic Equipment for use in Power Installations apply in whole or in part.

Safe Torque-off Wiring Requirements

The following are the safe torque-off (STO) wiring requirements. The wire must be copper with 75 °C (167 °F) minimum rating.

IMPORTANT The National Electrical Code and local electrical codes take precedence over the values and methods provided.

IMPORTANT Stranded wires must terminate with ferrules to prevent short circuits, per table D7 of EN ISO 13849.

Figure 48 - Safe Torque-off (STO) Terminal Plug

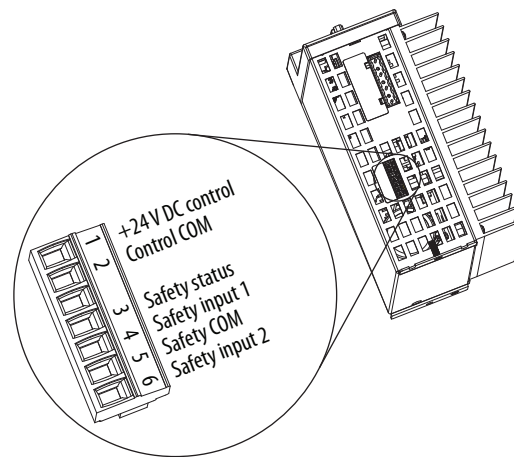

Table 42 - Safe Torque-off (STO) Terminal Plug Wiring

Safe Torque-off (STO) Connector		Recommended Wire Size		Strip Length mm (in.)	Torque Value N•m (lb•in)
Pin	Signal	Stranded Wire with Ferrule mm ² (AWG)	Solid Wire mm ² (AWG)		
STO-1 STO-2 STO-3 STO-4 STO-5 STO-6	+24V DC Control Control COM Safety Status Safety Input 1 Safety COM Safety Input 2	0.75 (18)	1.5 (16)	6 (0.25)	0.2 (1.8)

IMPORTANT Use only pins STO-1 (+24V DC Control) and STO-2 (Control COM) of the motion-allowed jumpers to defeat the safe torque-off function. When the safe torque-off function is in operation, the 24V supply must come from an external source.

IMPORTANT To be sure of system performance, run wires and cables in the wireways as established in the user manual for your drive.

Kinetix 350 Drive Safe Torque-off Feature

The safe torque-off circuit, when used with suitable safety components, provides protection according to EN ISO 13849-1 (PLd). The safe torque-off option is just one safety control system. All components in the system must be chosen and applied correctly to achieve the desired level of operator safeguarding.

The safe torque-off circuit is designed to remove power safely from the gate firing circuits of the drives output power devices (IGBTs). This prevents them from switching in the pattern necessary to generate AC power to the motor.

You can use the safe torque-off circuit in combination with other safety devices to meet the stop and protection-against-restart requirements of EN ISO 13849-1.



ATTENTION: This option is suitable for performing mechanical work on only the drive system or affected area of a machine. It does not provide electrical safety.



SHOCK HAZARD: In Safe Torque-off mode, hazardous voltages can still be present at the motor. To avoid an electric shock hazard, disconnect power to the motor and verify that the voltage is zero before performing any work on the motor.

Safe Torque-off Feature Bypass

The drive is supplied from the factory with the safe torque-off circuit enabled. The drive is not operational until +24V is present at terminals STO-4 and STO-6. When safety connections are not required, the drive can be operated with the safety circuit disabled.

Use jumper wires, as shown, to defeat the safe torque-off function.

Figure 49 - STO Motion-allowed Jumpers

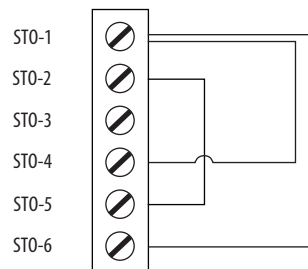

IMPORTANT Use only pins STO-1 (+24V DC Control) and STO-2 (Control COM) of the motion-allowed jumpers to defeat the safe torque-off function. When the safe torque-off function is in operation, the 24V supply must come from an external source.

Kinetix 350 Drive Safe Torque-off Wiring Diagrams

This section provides typical wiring diagrams for the Kinetix 350 drive safe torque-off feature with other Allen-Bradley safety products.

For additional information regarding Allen-Bradley safety products, including safety relays, light curtain, and gate interlock applications, refer to the Safety Products Catalog, website <http://www.rockwellautomation.com/global/catalogs/overview.page>.

The drive is shown in a single-axis relay configuration for category 0 stop per EN-60204-1 Safety of Machinery Directive. [Figure 50](#) and [Figure 51](#) are examples, however, and user applications can differ based on the required overall machine-performance level requirements.

IMPORTANT The Kinetix 350 drive meets the requirements of EN ISO 13849-1 Safety of Machinery, Safety-related Parts of Control Systems, category (CAT 3), performance level (PL)d and Safety Integrity Level (SIL) 2 per EN 61800-5-2:2007. Dual inputs and drive monitoring of the safe torque-off circuit, STO-4 and STO-6, are done to prevent drive enable if either or both of these inputs do not function.

It is suggested to evaluate the entire machine performance level that is required with a risk assessment and circuit analysis. Contact your local distributor or Rockwell Automation Sales for more information.

Figure 50 - Single-axis Relay Configuration (Stop Category 0) with Automatic Reset

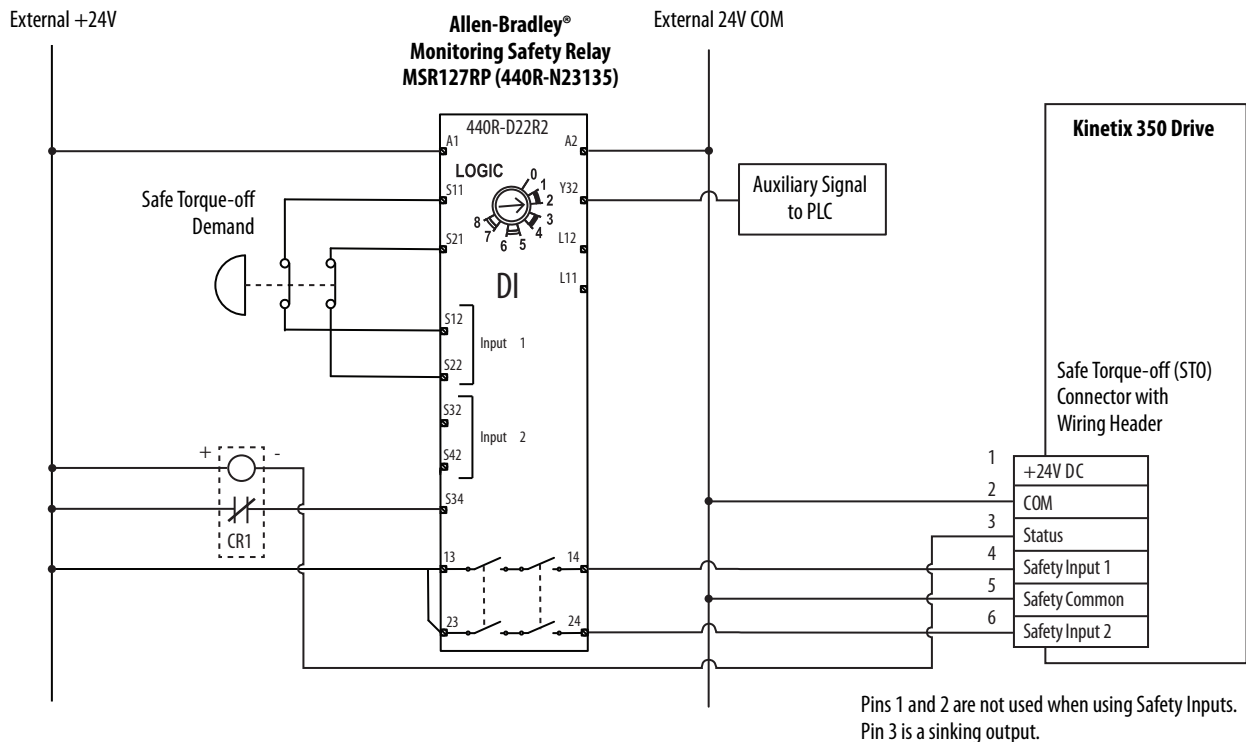
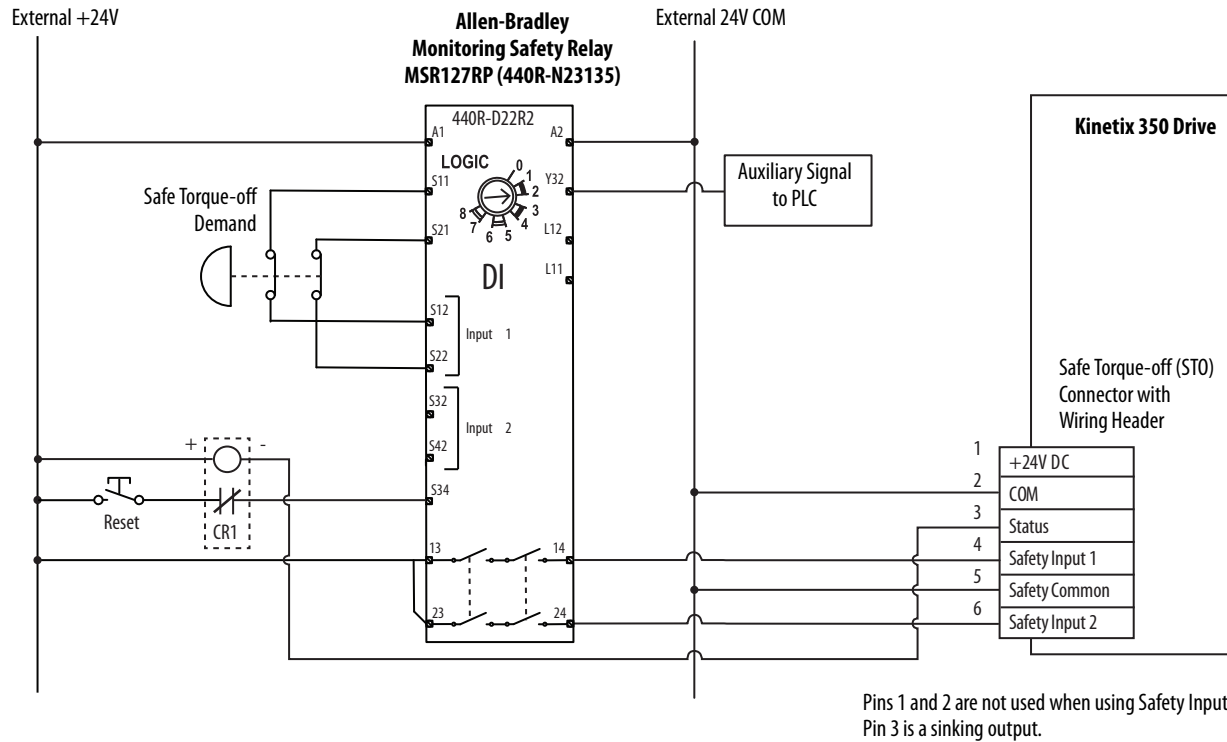

Figure 51 - Single-axis Relay Configuration (Stop Category 0) with Manual Reset



Safe Torque-off Signal Specifications

This table provides specifications for the safe torque-off signals that are used in the Kinetix 350 servo drives.

Attribute	Value
Safety inputs ⁽¹⁾	Insulated, compatible with single-ended output (+24V DC)
	Enable voltage range: 20...24V DC
	Disable voltage range: 0...1.0V DC
Input impedance	6.8 kΩ
Safety status	Isolated Open Collector (Emitter is grounded.)
Output load capability	100 mA
Digital outputs max voltage	30V DC

(1) Safety inputs are not designed for pulse testing.

Safety Input and Output Schematics

The following are generic safety input and output schematics for the Kinetix 350 drive.

Figure 52 - Safety Input

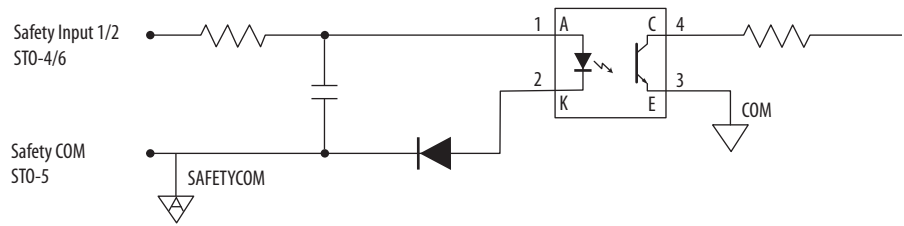
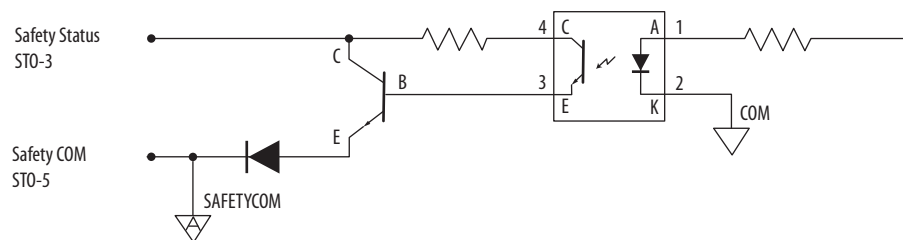

Figure 53 - Safety Status Output - Sinking Type



Troubleshoot the Kinetix 350 Drive

Topic	Page
Safety Precautions	111
Interpret Status Indicators	112
General System Behavior	120
Logix5000 Controller and Drive Behavior	124
Web Server Interface	128

Safety Precautions

Observe the following safety precautions when troubleshooting your Kinetix® 350 drive.



ATTENTION: Capacitors on the DC bus can retain hazardous voltages after input power has been removed. Before working on the drive, measure the DC bus voltage to verify it has reached a safe level or wait the full-time interval as indicated in the warning on the front of the drive. Failure to observe this precaution could result in severe bodily injury or loss of life.



ATTENTION: Do not attempt to defeat or override the drive fault circuits. You must determine the cause of a fault and correct it before you attempt to operate the system. Failure to correct the fault could result in personal injury and/or damage to equipment as a result of uncontrolled machine operation.



ATTENTION: Provide an earth ground for test equipment (oscilloscope) used in troubleshooting. Failure to ground the test equipment could result in personal injury.

Interpret Status Indicators

See these troubleshooting tables to identify faults, potential causes, and the appropriate actions to resolve the fault. If the fault persists after attempting to troubleshoot the system, please contact your Rockwell Automation sales representative for further assistance.

Four-digit Display Messages

The control modules include a four-digit seven-segment display for status and fault messages. The display scrolls to display text strings.

The Four-digit Display Messages table lists the messages along with their priorities. When messages of different priorities are to be displayed, for example, when the drive has both a fault and a start inhibit, only the higher priority message is displayed. When messages of equal priority are needed, for example, when there is multiple fault, the messages are displayed in a round-robin fashion. Only two messages scroll in this manner. When a fault is annunciated, the entire fault text scrolls on the display regardless of when the fault is cleared

The IP address is always an active condition, meaning that it scrolls with the axis state as long as there are no higher priority messages to display.

See the table on [Four-digit Display Messages](#) for a description of the messages that scroll across the display during powerup.

Table 43 - Four-digit Display Messages

Device Condition	Display Digit	Priority (Lower Is Higher)
IP address (always active)	xxx.xxx.xxx.xxx	
Executing device self-test	-08-	
Waiting for connection to controller	-00-	
Configuring device attributes	-01-	4
Waiting for group synchronization	-02-	
Waiting for DC Bus to charge	-03-	
Device is operational	-04-	
Start inhibit code	Sxx	3
Start inhibit code - custom	Scxx	
Axis fault code	Fxx	2
Axis fault code - custom	Fcxx	
Boot error	Lxxx	
Power on Self Test (POST) error	Pxxx	1
Initialization fault code - custom	Icxx	
Node fault code	nFxx	1

Error Codes

The following list helps you resolve memory anomalies.

When a fault is detected, the status indicator displays an E and a two-digit error code until the anomaly is cleared.

Error Code	Anomaly	Possible Cause	Action/Solution
E38	Memory module error.	Bad memory module.	Replace memory module.
E76	Blank memory module.	A Blank MEM module has been inserted into the drive.	Push and hold the drive's enter key (bottom most red button) on the drive's front display until the drive shows BUSY. This makes the drive format the blank memory module for usage with the drive.

Fault Codes

These fault code tables are designed to help you resolve anomalies. When a fault is detected, the four-digit status indicator scrolls the display message. The display is repeated until the fault code is cleared.

Table 44 - Fault Code Summary

Fault Code Type	Description
Sxx	Conditions that prevent the drive from enabling, see Table 45 .
Scxx	
Fxx	Standard axis fault, see Table 46 and Table 47 .
Fcxx	
Lxx	Unrecoverable errors that occur during the boot process. Return drive to Rockwell Automation.
Pxxx	Unrecoverable errors that occurred during the Power on Self Test (POST). Return drive to Rockwell Automation.
lctx	Anomalies that prevent normal operation and occur during the initialization process.
nFxx	Anomalies that prevent normal operation of the drive. Node Fault. This type of fault that impacts the servo drive not just the axis of motion.

Table 45 - Sxx and Scxx Start Inhibit Codes

Four-digit Display	RSLogix 5000® and Logix Designer Fault Message	Problem or Symptom	Potential Cause	Possible Resolution
S 01	Axis enable input.	The axis enable input is deactivated.	Axis Enable Input is not active.	<ul style="list-style-type: none"> Check wiring and 24V source for drive ENABLE Input. Disable enableInputChecking attribute by using a message instruction.

Table 45 - Sxx and Scxx Start Inhibit Codes (Continued)

Four-digit Display	RSLogix 5000® and Logix Designer Fault Message	Problem or Symptom	Potential Cause	Possible Resolution
S 02	Motor not configured.	The associated motor has not been configured for use.	Faulty intelligent encoder or incorrect motor file.	<ul style="list-style-type: none"> • Cycle power or reset the drive. • Check that proper motor has been selected in Logix Designer Application. • Replace motor if faulting continues.
S 03	Feedback not configured.	The associated feedback device has not been configured for use or the configuration does not match what is connected.		
Sc05	Safe torque off.	No power or safety circuitry not configured.	The safety function has disabled the power structure.	<ul style="list-style-type: none"> • Apply 24V sources to safety circuit. • Use jumpers to bypass safety circuit.

Table 46 - Fxx Fault Codes

Four-digit Display	RSLogix 5000 and Logix Designer Fault Message	Problem or Symptom	Potential Cause	Possible Resolution
F 02	Illegal Hall State	State of Hall feedback inputs is incorrect.	Improper connections.	<ul style="list-style-type: none"> • Check wiring of S1,S2, and S3 • Check the power supply to the encoder.
F 03	Motor Overspeed	Motor speed has exceeded 125% of maximum rated speed.		<ul style="list-style-type: none"> • Check motor wire phasing. • Check cables for noise. • Check tuning.
F 05	Motor Overtemperature	The motor thermostat, motor thermistor, or encoder temperature sensor indicates that the motor factory temperature limit has been exceeded.	High motor ambient temperature and/or Excessive Current.	<ul style="list-style-type: none"> • Check motor wiring at motor feedback (MF) connector. • Check TS+ and COM wiring. • Operate within (not above) the continuous torque rating for the ambient temperature. • Lower ambient temperature or increase motor cooling. • Verify that the proper motor has been selected.
F 07	Motor Thermal Protection	The thermal model for the motor indicates that the temperature has exceeded 110% of its rating.	The machine duty cycle requires an RMS current that exceeds the continuous rating of the motor.	Change the command profile to reduce speed or increase time.
F 10	Inverter Overcurrent	The drive fault output indicates that the power transistors were turned off because of overcurrent, overtemperature, or power supply problems.	Motor cables that are shorted.	Verify continuity of motor power cable and connector.
			Motor winding shorted internally.	Disconnect motor power cables from the motor. Use multimeter to check that the resistance of phase-to-phase is not open and that phase-to-ground is open.
			The drive temperature is too high.	<ul style="list-style-type: none"> • Check for clogged vents or defective fan. • Make sure that cooling is not restricted by insufficient space around the unit. • Verify that ambient temperature is within the specification. See Kinetix 350 Drive Power Specifications in Kinetix Servo Drives Specifications Technical Data, publication KNX-TD003.
			Operation above continuous power rating and/or product environmental ratings.	<ul style="list-style-type: none"> • Operate within the continuous power rating. • Reduce acceleration rates.
			The drive has a short circuit, overcurrent, or failed component.	Remove all power and motor connections, and perform a continuity check from the DC bus to the U, V, and W motor outputs. If a continuity exists, check for wire fibers between terminals, or send drive in for repair.
			Loss of TTL signal	Check AM+, AM-, BM+, and BM-signals.

Table 46 - F xx Fault Codes (Continued)

Four-digit Display	RSLogix 5000 and Logix Designer Fault Message	Problem or Symptom	Potential Cause	Possible Resolution
F 11	Inverter Overtemperature	Inverter thermal switch tripped.	Drive fan failed.	Replace the failed drive.
			The cabinet ambient temperature is above rating.	Check the cabinet temperature. See Kinetix 350 Drive Power Specifications in Kinetix Servo Drives Specifications Technical Data, publication KNX-TD003
			The machine duty cycle requires an RMS current that exceeds the continuous rating of the controller.	Change the command profile to reduce speed or increase time.
			The airflow access to the drive system is limited or blocked.	Check airflow and reroute cables away from the drive system.
F 13	Inverter Thermal Protection	The thermal model for the power transistors indicates that the temperature has exceeded 110% of its rating.	The machine duty cycle requires an RMS current that exceeds the continuous rating of the controller.	Change the command profile to reduce speed or increase time.
			Motor brake on.	Turn off motor brake.
F 33	Bus Undervoltage	With three-phase power present, the DC bus voltage is below limits.	DC bus voltage for 460V system is below 275V. DC bus voltage for 230V system is below 137V. DC bus voltage for 120V system is below 80V	<ul style="list-style-type: none"> Verify voltage level of the incoming AC power. Check AC power source for glitches or line drop. Install an uninterpretable power supply (UPS) on your AC input.
F 35	Bus Overvoltage	The DC bus voltage is measured above a factory limit.	Excessive regeneration of power.	Change the deceleration or motion profile.
			When the motor is driven by an external mechanical power source, it can regenerate too much peak energy through the drive power supply. The system faults to save itself from an overload.	Use a larger system (motor and drive).
			DC bus voltage for 460V system is over 820V.	Install shunt resistor.
F 43	Feedback Loss	<ul style="list-style-type: none"> On sin/cos encoders, the sum of the square of the sin/cos signals has been measured below a factory limit. On TTL encoders, the absolute value of the differential A/B signals is below a factory limit. 	The motor feedback wiring is open, shorted, or missing.	<ul style="list-style-type: none"> Check motor encoder wiring. Run Hookup test in RSLogix 5000 software.
F 45	Feedback Serial Comms (only TL-Series™ motors and actuators)	The number of consecutive missed or corrupted serial data packets from the feedback device has exceeded a factory set limit.	Communication was not established with an intelligent encoder.	<ul style="list-style-type: none"> Verify motor selection. Verify motor encoder wiring.
F 47	Feedback Self Test	The feedback device has detected an internal error.	Damage to feedback device.	Call your Rockwell Automation sales representative to return motor for repair.
F 50	Hardware Overtravel - Positive	Axis that is moved beyond the physical travel limits in the positive direction.	Dedicated overtravel input is inactive.	<ul style="list-style-type: none"> Check wiring. Verify motion profile. Verify axis configuration in software.
F 51	Hardware Overtravel - Negative	Axis that is moved beyond the physical travel limits in the negative direction.		
F 54	Excessive Position Error	Position error limit was exceeded.	Partial loss of feedback signals.	Check all wiring at motor feedback (MF) connector.
			Improperly sized drive or motor.	Verify sizing of system.
			Mechanical system out of specifications.	<ul style="list-style-type: none"> Increase the feed forward gain. Increase following error limit or time. Check position loop tuning. Verify mechanical integrity of system within specification limits. Check motor power wiring.

Table 46 - F xx Fault Codes (Continued)

Four-digit Display	RSLogix 5000 and Logix Designer Fault Message	Problem or Symptom	Potential Cause	Possible Resolution
F 55	Excessive Velocity Error	Velocity Error value of the velocity control loop has exceeded the configured value for Velocity Error Tolerance.	Partial loss of feedback signals.	Check all wiring at motor feedback (MF) connector.
			Improperly sized drive or motor.	<ul style="list-style-type: none"> Increase velocity error limit or time. Check velocity loop tuning. Verify sizing of system.
			Mechanical system out of specifications.	<ul style="list-style-type: none"> Increase velocity error limit or time. Check velocity loop tuning. Verify mechanical integrity of system within specification limits. Check motor power wiring. Reduce acceleration.
F 56	Overtorque Limit	Motor torque has exceeded a user-programmable setting.	<ul style="list-style-type: none"> Overly aggressive motion profile. Mechanical binding. 	<ul style="list-style-type: none"> Verify motion profile. Verify that Overtorque settings are appropriate. Verify sizing of system. Verify torque offset
			Mechanical system out of specifications.	Verify mechanical integrity of system within specification limits.
F 57	Undertorque Limit	Motor torque has fallen below a user-programmable setting.	<ul style="list-style-type: none"> Improperly configured limit. Improperly configured motion. Improperly drive/motor sizing. 	<ul style="list-style-type: none"> Verify motion profile. Verify that Overtorque settings are appropriate. Verify sizing of system.
			Mechanical system out of specifications.	Verify mechanical integrity of system within specification limits.
F 61	Drive Enable Input	The hardware enable input was deactivated while the drive was enabled. This is applicable when only drive enable input is used.	An attempt was made to enable the axis through software while the Drive Enable hardware input was inactive.	<ul style="list-style-type: none"> Check wiring of drive enable input. Check 24V source.
			The Drive Enable input that has transitioned from active to inactive while the axis was enabled.	Verify that Drive Enable hardware input is active whenever the drive is enabled through software.
F 62	Controller Initiated Exception	The controller has requested the drive to generate an exception.	User configured software overtravel.	<ul style="list-style-type: none"> Move axis out of soft overtravel range. Clear soft overtravel fault. Check soft overtravel configuration. Consult controller documentation.

Table 47 - Fc xx Fault Codes

Four-digit Display	RSLogix 5000 and Logix Designer Fault Message	Problem or Symptom	Potential Cause	Possible Resolution
Fc 02	Motor Voltage Mismatch	Motor voltage incompatible with drive voltage.	Wrong motor has been connected to drive.	Connect appropriate motor to drive.
Fc 05	Motor Encoder Battery Loss (applies to Bulletin TLY motors with B feedback)	The battery voltage on a battery-backed motor encoder is low enough such that a power loss has caused the absolute position to be no longer available.	Weak battery or poor battery connection.	<ul style="list-style-type: none"> Replace battery. Check battery connection.
Fc 06	Motor Encoder Battery Low (applies to Bulletin TLY motors with B feedback)	The battery voltage on a battery-backed motor encoder is low enough such that a power loss causes the absolute position to be lost.		
Fc 14	Excessive Current Feedback Offset	Current in one or more phases have been lost or remains below a preset level.		Replace the drive.
Fc 26	Runtime Drive Error	The drive firmware encountered an unrecoverable runtime error.		<ul style="list-style-type: none"> Cycle control power. Replace drive.

Table 48 - Ic_{xx} Fault Codes

Four-digit Display	RSLogix 5000 and Logix Designer Fault Message	Problem or Symptom	Potential Cause	Possible Resolution
Ic 01	Boot Block Check Sum Fault	The motor data that is stored in a smart encoder has a checksum error.	Faulty intelligent encoder.	<ul style="list-style-type: none"> • Cycle power or reset the drive. • Replace motor if faulting continues.
Ic 02	Motor Data Range Error	Data within a motor data blob is out of range.	Faulty intelligent encoder or incorrect motor file.	<ul style="list-style-type: none"> • Cycle power or reset the drive. • Check validity of the motion database. • Replace motor if faulting continues.
Ic 03	Motor Feedback Communication Startup	Communication with a smart encoder could not be established on the motor feedback port.	An incorrect motor has been selected or connected.	Check motor selection.
			Faulty wiring.	Check motor encoder wiring.
Ic 06	Motor Absolute Startup Speed	The motor absolute encoder was not able to determine the position after powerup due to motor speed greater than 100 rpm.	Mechanical movement of machine has caused excessive rotation of motor during powerup.	Allow machine motion to stop before powerup.

Status messages of the format L_{xxx} indicate an unrecoverable error while starting the drive. Reload firmware and restart the drive, if status message repeats contact Rockwell Automation technical support to return drive for repair.

Table 49 - L_{xxx} Fault Codes

Four-digit Display Message	Cause
L001	Identity block corrupted
L002	Firmware file load failed
L004	Firmware not programmed (drive is new)
L008	DSP load operation failed

Status messages of the format P_{xxx} indicate an unrecoverable error during the Power-on Self Test (POST). Contact Rockwell Automation technical support to return drive for repair.

Table 50 - P_{xxx} Fault Codes

Four-digit Display Message	Cause
P001	SDRAM test failed
P002	FPGA load operation failed
P004	DPRAM Test failed
P005	DSP I/F to DPram - no DSP response
P006	I/F to DPram failed
P007	Firmware file md5 test failure

Table 51 - nF xx Fault Codes

Four-digit Display	RSLogix 5000 and Logix Designer Fault Message	Problem or Symptom	Potential Cause	Possible Resolution
nF 01	Control Update Fault	Several consecutive updates from the controller have been lost.	Excessive network traffic.	<ul style="list-style-type: none"> Remove unnecessary network devices from the motion network. Change the network topology so that fewer devices share common paths. Use faster/higher performance network equipment.
			Noisy environment.	<ul style="list-style-type: none"> Segregate signal wiring from power wiring. Use shielded cables. Add snubbers to power devices.
nF 02	Processor Watchdog Fault	The watchdog-circuit monitoring processor operation detected a problem.		<ul style="list-style-type: none"> Recycle control power or reset the drive. Replace control module if problem persists.
nF 03	Hardware Fault	The drive has an internal hardware problem.		<ul style="list-style-type: none"> Recycle control power or reset the drive. Replace drive.
		Nonvolatile write or write to memory failed.	Faulty memory component.	<ul style="list-style-type: none"> Recycle control power or reset the drive. Replace drive if problem persists.
nF 04	Data Format Error	A data format error was discovered in the controller-to-drive message.	Faulty memory component.	<ul style="list-style-type: none"> Recycle control power or reset the drive. Replace control module if problem persists.

Status Indicators

Table 52 - Drive Status Indicator

Status	Description
Off	No power. Apply power.
Alternating green/red	Self-test (power-up diagnostics). Wait for steady green.
Flashing green	Standby (device not configured). Wait for steady green.
Steady green	Normal operation, no faults.
Flashing red	Minor fault (recoverable). See four-digit fault message.
Steady red	Major fault (non-recoverable). See four-digit fault message.

Table 53 - Axis Status Indicator

Status	Description
Off	Off
Flash red/green	Self test
Off	Initialization - bus not up
Flashing green	Initialization - bus up
Off	Shutdown - bus not up
Flashing amber ⁽¹⁾	Shutdown - bus up
Off	Pre-charge - bus not up
Flashing amber ⁽¹⁾	Start inhibit
Flashing green ^{(1) (2)}	Stopped
Solid green ^{(1) (2)}	Stopping
	Starting
	Running
	Testing
Flashing red	Aborting
	Major faulted
Solid red	Aborting
	Major faulted

(1) The axis and the drive define minor fault conditions. While a minor fault does not affect the drive status indicator, it does affect the axis status indicator. When a minor fault condition is detected, a normally solid-green status indicator indication changes to alternating red-green-red-green, a normally flashing green status indicator indication changes to alternating red-off-green-off, and a normally flashing amber indications changes to red-off-amber-off.

(2) The drive also defines alarm conditions. When an alarm condition is detected, a normally solid-green status indicator indication changes to alternating amber-green-amber green while a normally flashing green status indicator indication changes to alternating amber-off-green-off.

Table 54 - Network Status Indicators

Status	Description
Off	No power or no IP address defined.
Alternating green/red	Self-test mode (power-up diagnostics).
Flashing green	Standby (device that is not configured, or connection not established).
Steady green	Normal operation. Device has at least one established connection.
Flashing red	Recoverable minor fault or connection timeout.
Steady red	Non-recoverable major fault or duplicate IP address.

IMPORTANT Under some fault conditions, two reset commands can be required to clear drive.

Table 55 - Port 1 Ethernet Communication Status Indicators

Status	Description
Off	No link partner present.
Flashing green	Link partner present, communication occurring.
Steady green	Link partner present, no communication occurring.

General System Behavior

These events do not always result in a fault code, but can require troubleshooting to improve performance.

Table 56 - General System Behavior

Condition	Potential Cause	Possible Resolution
Axis or system is unstable.	The position feedback device is incorrect or open.	Check wiring.
	Unintentionally in Torque mode.	Check to see what primary operation mode was programmed.
	Motor tuning limits are set too high.	Run Tune in RSLogix 5000 software.
	Position loop gain or position controller accel/decel rate is improperly set.	Run Tune in RSLogix 5000 software.
	Improper grounding or shielding techniques are causing noise to be transmitted into the position feedback or velocity command lines, causing erratic axis movement.	Check wiring and ground.
	Motor Select limit is incorrectly set (servo motor is not matched to axis module).	<ul style="list-style-type: none"> Check setups. Run Tune in RSLogix 5000 software.
	Mechanical resonance.	Notch filter or output filter can be required (refer to Axis Properties dialog box, Output tab in RSLogix 5000 software).

Table 56 - General System Behavior (Continued)

Condition	Potential Cause	Possible Resolution
You cannot obtain the motor acceleration/deceleration that you want.	Torque Limit limits are set too low.	Verify that current limits are set properly.
	Incorrect motor that is selected in configuration.	Select the correct motor and run Tune in Logix Designer Application again.
	The system inertia is excessive.	<ul style="list-style-type: none"> Check motor size versus application need. Review servo system sizing.
	The system friction torque is excessive.	Check motor size versus application need.
	Available current is insufficient to supply the correct accel/decel rate.	<ul style="list-style-type: none"> Check motor size versus application need. Review servo system sizing.
	Acceleration limit is incorrect.	Verify limit settings and correct them, as necessary.
	Velocity Limit limits are incorrect.	Verify limit settings and correct them, as necessary.
Motor does not respond to a velocity command.	The axis cannot be enabled for 1.5 seconds after disabling.	Disable the axis, wait for 1.5 seconds, and enable the axis.
	Enable signal has not been applied or the enable wiring is incorrect.	<ul style="list-style-type: none"> Check the controller. Check the wiring.
	The motor wiring is open.	Check the wiring.
	The motor thermal switch has tripped.	<ul style="list-style-type: none"> Check for a fault. Check the wiring.
	The motor has malfunctioned.	Repair or replace the motor.
	The coupling between motor and machine has broken (for example, the motor moves, but the load/machine does not).	Check and correct the mechanics.
	Primary operation mode is set incorrectly.	Check and properly set the limit.
	Velocity or current limits are set incorrectly.	Check and properly set the limits.
Presence of noise on command or motor feedback signal wires.	Recommended grounding per installation instructions have not been followed.	<ul style="list-style-type: none"> Verify grounding. Route wire away from noise sources. See System Design for Control of Electrical Noise, publication GMC-RM001.
	Line frequency can be present.	<ul style="list-style-type: none"> Verify grounding. Route wire away from noise sources.
	Variable frequency can be velocity feedback ripple or a disturbance that is caused by gear teeth or ballscrew balls, and so forth. The frequency can be a multiple of the motor power transmission components or ballscrew speeds resulting in velocity disturbance.	<ul style="list-style-type: none"> Decouple the motor for verification. Check and improve mechanical performance, for example, the gearbox or ballscrew mechanism.
No rotation	The motor connections are loose or open.	Check motor wiring and connections.
	Foreign matter is lodged in the motor.	Remove foreign matter.
	The motor load is excessive.	Verify the servo system sizing.
	The bearings are worn.	Return the motor for repair.
	The motor brake is engaged (if supplied).	<ul style="list-style-type: none"> Check brake wiring and function. Return the motor for repair.
	The motor is not connected to the load.	Check coupling.
Motor overheating	The duty cycle is excessive.	Change the command profile to reduce accel/decel or increase time.
	The rotor is partially demagnetized causing excessive motor current.	Return the motor for repair.

Table 56 - General System Behavior (Continued)

Condition	Potential Cause	Possible Resolution
You cannot obtain the motor acceleration/deceleration that you want.	Torque Limit limits are set too low.	Verify that current limits are set properly.
	Incorrect motor that is selected in configuration.	Select the correct motor and run Tune in Logix Designer Application again.
	The system inertia is excessive.	<ul style="list-style-type: none"> Check motor size versus application need. Review servo system sizing.
	The system friction torque is excessive.	Check motor size versus application need.
	Available current is insufficient to supply the correct accel/decel rate.	<ul style="list-style-type: none"> Check motor size versus application need. Review servo system sizing.
	Acceleration limit is incorrect.	Verify limit settings and correct them, as necessary.
	Velocity Limit limits are incorrect.	Verify limit settings and correct them, as necessary.
Motor does not respond to a velocity command.	The axis cannot be enabled for 1.5 seconds after disabling.	Disable the axis, wait for 1.5 seconds, and enable the axis.
	Enable signal has not been applied or the enable wiring is incorrect.	<ul style="list-style-type: none"> Check the controller. Check the wiring.
	The motor wiring is open.	Check the wiring.
	The motor thermal switch has tripped.	<ul style="list-style-type: none"> Check for a fault. Check the wiring.
	The motor has malfunctioned.	Repair or replace the motor.
	The coupling between motor and machine has broken (for example, the motor moves, but the load/machine does not).	Check and correct the mechanics.
	Primary operation mode is set incorrectly.	Check and properly set the limit.
	Velocity or current limits are set incorrectly.	Check and properly set the limits.
Presence of noise on command or motor feedback signal wires.	Recommended grounding per installation instructions have not been followed.	<ul style="list-style-type: none"> Verify grounding. Route wire away from noise sources. See System Design for Control of Electrical Noise, publication GMC-RM001.
	Line frequency can be present.	<ul style="list-style-type: none"> Verify grounding. Route wire away from noise sources.
	Variable frequency can be velocity feedback ripple or a disturbance that is caused by gear teeth or ballscrew balls, and so forth. The frequency can be a multiple of the motor power transmission components or ballscrew speeds resulting in velocity disturbance.	<ul style="list-style-type: none"> Decouple the motor for verification. Check and improve mechanical performance, for example, the gearbox or ballscrew mechanism.
No rotation	The motor connections are loose or open.	Check motor wiring and connections.
	Foreign matter is lodged in the motor.	Remove foreign matter.
	The motor load is excessive.	Verify the servo system sizing.
	The bearings are worn.	Return the motor for repair.
	The motor brake is engaged (if supplied).	<ul style="list-style-type: none"> Check brake wiring and function. Return the motor for repair.
	The motor is not connected to the load.	Check coupling.
Motor overheating	The duty cycle is excessive.	Change the command profile to reduce accel/decel or increase time.
	The rotor is partially demagnetized causing excessive motor current.	Return the motor for repair.

Table 56 - General System Behavior (Continued)

Condition	Potential Cause	Possible Resolution
Abnormal noise	Motor tuning limits are set too high.	Run Tune in RSLogix 5000 software.
	Loose parts are present in the motor.	<ul style="list-style-type: none"> • Remove the loose parts. • Return motor for repair. • Replace motor.
	Through bolts or coupling is loose.	Tighten bolts.
	The bearings are worn.	Return motor for repair.
	Mechanical resonance.	Notch filter can be required (refer to Axis Properties dialog box, Output tab in RSLogix 5000 software).
Erratic operation - Motor locks into position, runs without control or with reduced torque.	Motor power phases U and V, U and W, or V and W reversed.	Check and correct motor power wiring.
	Sine, cosine, or rotor leads are reversed in the feedback cable connector.	Check and correct motor feedback wiring.
	Sine, cosine, rotor lead sets of resolver feedback are reversed.	Check and correct motor feedback wiring.
No motion from a motor with a TTL encoder, axis is enabled and there are no faults	Sine and cosine signals are broken.	Check feedback wiring.

Logix5000 Controller and Drive Behavior

By using Logix Designer Application, you can configure how the Bulletin 2097 drives respond when a drive fault/exception occurs.

TIP The lxx faults are always generated after powerup, but before the drive is enabled, so the stopping behavior does not apply.

Kinetix 350 Drive Exception Behavior

For Kinetix 350 drives, you can configure exception behavior in RSLogix 5000 software from the Axis Properties dialog box, Actions category.

Table 57 - Kinetix 350 Drive Exception Action Definitions

Exception Action	Definition
Ignore	The controller completely ignores the exception condition. For some exceptions that are fundamental to the operation of the planner, Ignore is not an available option.
Alarm	The controller sets the associated bit in the Motion Alarm Status word but does not otherwise affect axis behavior. Like Ignore, if the exception is so fundamental to the drive, Alarm is not an available option. When an exception action is set to Alarm, the Alarm goes away by itself when the exceptional condition has cleared.
Fault Status Only	Fault Status Only instructs the controller to set the associated bit in the Motion Fault Status word, but does not otherwise affect axis behavior. However, an explicit Fault Reset is required to clear the fault once the exceptional condition has cleared. If the exception is so fundamental to the drive, Fault Status Only is not an available option.
Stop Planner	The controller sets the associated bit in the Motion Fault Status word and instructs the Motion Planner to perform a controlled stop of all planned motion at the configured maximum deceleration rate. An explicit Fault Reset is required to clear the fault once the exceptional condition has cleared. If the exception is so fundamental to the drive, Stop Planner is not an available option.
Stop Drive	When the exception occurs, the associated bit in the Fault Status word is set and the axis comes to a stop by using the stopping action that is defined by the drive for the particular exception that occurred. There is no controller-based configuration to specify what the stopping action is, the stopping action is device-dependent.
Shutdown	When the exception occurs, the drive brings the motor to a stop by using the stopping action that is defined by the drive (as in Stop Drive) and the power module is disabled. Optionally, if the Shutdown Action attribute is configured for Drop DC Bus, the contactor opens. An explicit Shutdown Reset is required to restore the drive to operation.

IMPORTANT The fault detection ability of TTL encoders is not as advanced as with Stegmann hiperface or Tamagawa 17-bit serial encoders. When a TTL encoder loses its A/B signals, the Kinetix 350 drive is unable to detect this fault directly. Instead it relies on a secondary fault to detect the condition, typically excessive position or velocity error. There are some cases, particularly in Torque mode where the fault isn't detected at all. In this case, the motor coasts to a stop, but is still enabled in Logix Designer application.

Only selected drives faults can be configured. In the [Drive Behavior, F xx Fault Codes](#) tables, the controlling attribute is given for programmable fault actions.

Figure 54 - RSLogix 5000 Axis Properties - Actions Category

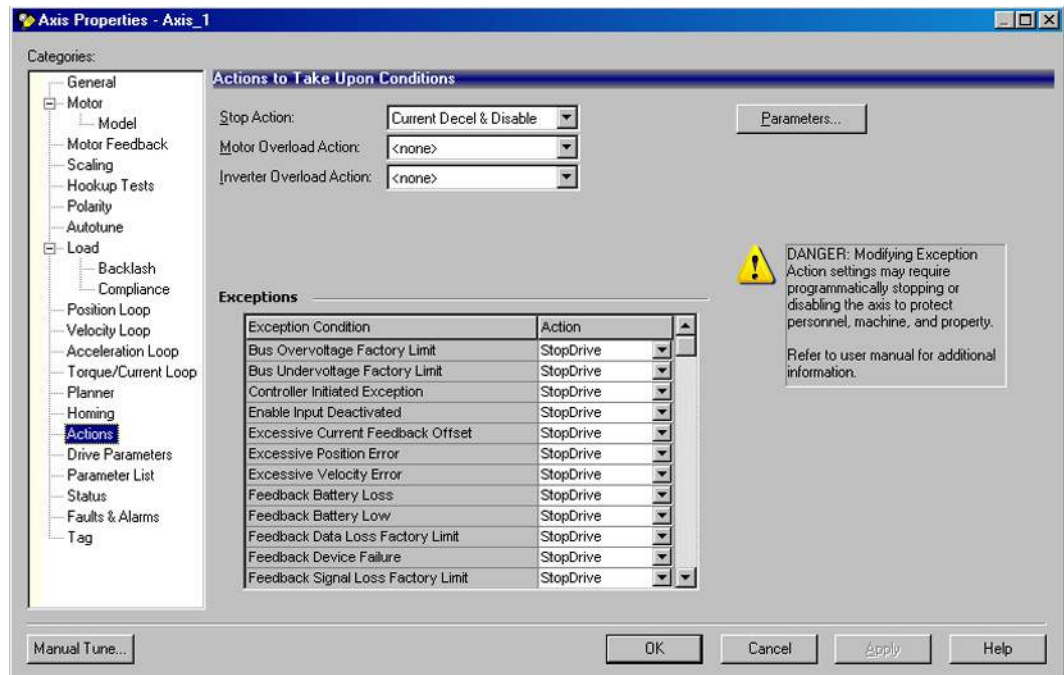

Table 58 - Drive Behavior, F xx Fault Codes

Four-digit Display	Exception	Description	Best Stopping Method (Only Major Fault)
F 02	Motor Commutation	Permanent magnet motor commutation problem detected. For example, illegal state 111 or 000 for a UVW commutation device. This exception is supported for only TTL motors with Hall sensors.	Disable/Coast
F 03	Motor Overspeed	Motor speed has exceeded its maximum limit that is given by the Motor Overspeed Factory Limit attribute that is associated with the motor type. This exception triggers when either the electrical frequency exceeds 500 Hz or the motor is command to go 125% of its max rated speed.	Disable/Coast
F 05	Motor Overtemperature	Motor temperature has exceeded its factory set temperature limit that is given by Motor Overtemperature Factory Limit, or the integral motor thermal switch has tripped.	Disable/Coast
F 07	Motor Thermal Overload	Motor thermal model has exceeded its factory set thermal capacity limit that is given by Motor Thermal Overload Factory Limit. This limit is 108 °C (226 °F) for the Kinetix 350 drive.	Decel/Disable
F 10	Inverter Overcurrent	Inverter current has exceeded the factory set peak or instantaneous current limit. This limit is set to 450% of the rated drive current for a single phase.	Disable/Coast
F 11	Inverter Overtemperature	Inverter temperature has exceeded its factory set temperature limit that is given by Inverter Overtemperature Factory Limit. Detected when an internal temperature sensor senses 108 °C (226 °F).	Disable/Coast
F 13	Inverter Thermal Overload	Inverter thermal model has exceeded its factory set thermal capacity limit that is given by Inverter Thermal Overload Factory Limit. This threshold is set to 108 °C (226 °F).	Disable/Coast
F 33	Bus Undervoltage	DC Bus voltage level is below the factory set limit that is given by Bus Undervoltage Factory Limit. This limit is set at 75% of the nominal voltage as determined on powerup.	Decel/Disable
F 35	Bus Overvoltage	DC Bus voltage level is above the factory set limit that is given by Bus Overvoltage Factory Limit. For 240V drives the limit is 420V. For 480V drives, the limit is 840V.	Disable/Coast

Table 58 - Drive Behavior, F.xx Fault Codes (Continued)

Four-digit Display	Exception	Description	Best Stopping Method (Only Major Fault)
F 43 ⁽¹⁾	Feedback Signal Loss	One or more A/B channel signals from a feedback device are open, shorted, missing, or severely attenuated. Specifically, the detected voltage levels of the signals are below the Feedback Signal Loss Factory Limit. The offending feedback channel is encoded in the associated Fault/Alarm Sub Code.	Disable/Coast
F 45	Feedback Data Loss	The number of consecutive missed or corrupted serial data packets over the serial data channel from a feedback device has exceeded the Feedback Data Loss Factory Limit. The offending feedback channel is encoded in the associated Fault/Alarm Sub Code. The threshold is set at four misses.	Disable/Coast
F 47	Feedback Device Failure	The feedback device has detected an internal error. Stegmann encoders return an error code and Tamagawa encoders have an error flag.	Disable/Coast
F 50	Hardware Overtravel Positive	Axis that is moved beyond the physical travel limits in the positive direction and activated the Positive Overtravel limit switch.	Decel/Disable
F 51	Hardware Overtravel Negative	Axis that is moved beyond the physical travel limits in the negative direction and activated the Negative Overtravel limit switch.	Decel/Disable
F 54 ⁽¹⁾	Excessive Position Error	The Position Error value of the position control loop has exceeded the configured value for Position Error Tolerance.	Decel/Disable
F 55 ⁽¹⁾	Excessive Velocity Error	The Velocity Error value of the velocity control loop has exceeded the configured value for Velocity Error Tolerance.	Decel/Disable
F 56	Overtorque Limit	Motor torque has risen above user-defined maximum torque level that is given by Overtorque Limit.	Decel/Disable
F 57	Undertorque Limit	Motor torque has dropped below user-defined minimum torque level that is given by Undertorque Limit.	Decel/Disable
F 61	Enable Input Deactivated	Enable has been deactivated while the axis is in Running state.	Decel/Disable
F 62	Controller Initiated Exception	Exception generated specifically by controller.	Disable/Coast

(1) When a TTL encoder loses its A/B signals, it is not detected directly. Instead a secondary fault to detect the condition, typically excessive position or velocity error. In this case, the motor coasts to a stop, but is still be enabled in Logix Designer application.

IMPORTANT The fault detection ability of TTL encoders is not as advanced as with Stegmann Hiperface or Tamagawa 17-bit serial encoders. When a TTL encoder loses its A/B signals, the Kinetix 350 drive is unable to detect this fault directly. Instead it relies on a secondary fault to detect the condition, typically excessive position or velocity error. There are some cases, particularly in Torque mode where the fault isn't detected at all. In this case, the motor coasts to a stop, but is still enabled in Logix Designer application.

Table 59 - Drive Behavior, Fc.xx Custom Fault Codes

Four-digit Display	Exception	Description	Best Stopping Method (Only Major Fault)
Fc02	Motor Voltage Mismatch	The motor voltage is incompatible with the applied drive voltage.	Disable/Coast
Fc05	Feedback Battery Loss	The battery voltage on a battery-backed motor encoder is low enough such that absolute position is not longer available. This fault occurs when the battery is too low and encoder main power has been removed.	Decel/Disable
Fc06	Feedback Battery Low	The battery voltage on a battery-backed motor encoder is below a caution level. This fault occurs when the battery is too low, but main power has not yet been removed.	Decel/Disable

Table 59 - Drive Behavior, Fc_{xx} Custom Fault Codes (Continued)

Four-digit Display	Exception	Description	Best Stopping Method (Only Major Fault)
Fc14	Excessive Current Feedback Offset	Current in one or more phases have been lost or remains below a preset level.	Disable/Coast
Fc26	Runtime Error	Runtime Assertions have been detected.	Disable/Coast
Fc63	Product Specific	Product Specific (exotic) exceptions by Sub Code.	Disable/Coast

A node fault is a fault that impacts the whole drive.

Table 60 - Drive Behavior, nF_{xx} Node Fault Codes

Four-digit Display	Name	Description	Best Stopping Method
nF01	Control Connection Update Fault	The Control Connection Update Fault code is used to indicate that updates from the controller over the controller to drive connection have been excessively late as determined by the Controller Update Delay High Limit attribute value.	Disable/Coast
nF02	Processor Watchdog Fault	The Processor Watchdog Fault code indicates that the processor that is associated with the device node has experienced an excessive overload condition that has tripped the associated processor watchdog mechanism.	Disable/Coast
nF03	Hardware Fault	The Hardware Fault code indicates that the critical support hardware such as the FPGA or ASIC associated with the device node has experienced a fault condition. This fault occurs when the EPM module has been removed.	Disable/Coast
nF04	Data Format Error	This fault code indicates that an error has occurred in the data format between the controller and the device, such as a Format Revision mismatch.	Disable/Coast
nF06	Control Connection Loss Fault	The Control Connection Loss fault code indicates that the Motion controller to drive connection from the controller has timed out.	Disable/Coast

Web Server Interface

The Kinetix 350 drive supports a basic web interface for common status reporting and network configuration attributes. No attributes are configurable from this page. To access the page, open a web browsers program and enter the IP address of the drive.

Figure 55 - Main Page



Figure 56 - Fault Page

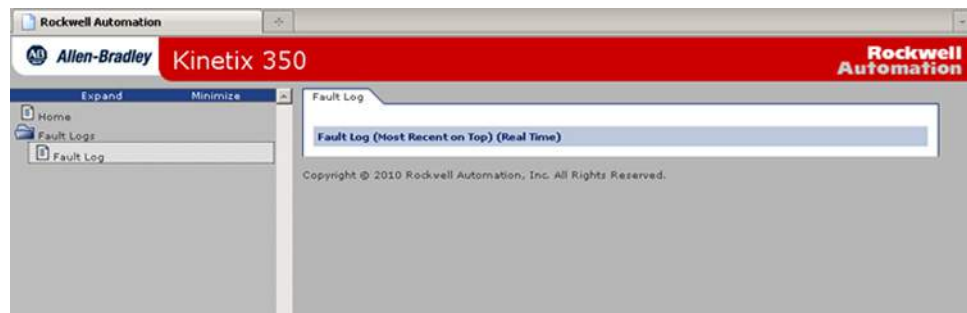

Interconnect Diagrams

Topic	Page
Interconnect Diagram Notes	130
Power Wiring Examples	131
Kinetix 350 Drive/Rotary Motor Wiring Examples	134
Kinetix 350 Drive/Actuator Wiring Examples	137
Motor Brake Currents	140
System Block Diagrams	141

Interconnect Diagram Notes

This appendix provides wiring examples to assist you in wiring the Kinetix® 350 system. These notes apply to the wiring examples on the pages that follow.

Note	Information
1	For power wiring specifications, refer to Power Wiring Requirements on page 60 .
2	For input fuse and circuit breaker sizes, refer to page 18 .
3	Place the AC (EMC) line filters as close to the drive as possible and do not route very dirty wires in the wireway. If routing in wireway is unavoidable, use shielded cable with shields that are grounded to the drive chassis and filter case. For AC line filter specifications, refer to Kinetix 350 Drive Power Specifications in Kinetix Servo Drives Specifications Technical Data, publication KNX-TD003 . This filter does not apply to 2097-V32PRx-LM drives because they have integrated AC line filters.
4	Terminal block is required to make connections.
5	Contact coil (M1) needs integrated surge suppressors for AC coil operation. See page 18 .
6	See the Motor Brake Currents table on page 140 to size the interposing relay for your application and for a detailed schematic of brake implementation.
7	Drive Enable input must be opened when main power is removed, or a drive fault occurs. A delay of at least 1.0 second must be observed before attempting to enable the drive after main power is restored.
8	Cable shield clamp must be used to meet CE requirements. No external connection to ground is required.
9	For motor cable specifications, refer to the Kinetix Motion Accessories Specifications Technical Data, publication KNX-TD004 .
10	Motor power cables (catalog numbers 2090-XXNPMF-xxSxx and 2090-CPBM6DF-16AAxx) have a drain wire that must be folded back under the cable shield clamp.
11	MPL-Axxx and MPL-B15xxx-H...MPL-B45xxx-H, MPM-Axxx, MPF-Axxx, MPS-Axxx, MPAR-Axxx, MPAL-Axxx, and MPAS-Axxx, encoders use the +5V DC supply.
12	MPL-B15xxx-S/M...MPL-B45xxx-S/M, MPM-Bxxx, MPF-Bxxx, MPS-Bxxx, MPAR-Bxxx, MPAL-Bxxx, and MPAS-Bxxx, encoders use +9V DC.
13	Brake connector pins are labeled plus (+) and minus (-) or F and G respectively. Power connector pins are labeled U, V, W, and GND or A, B, C, and D respectively.

Power Wiring Examples

You must supply input power components. The single-phase and three-phase line filters are wired downstream of fusing and the M1 contactor.

In this example, the 2097-V31PRx-LM drives are wired to use the voltage doubling circuit. The 120V input voltage provides 240V output to motors. The 2097-V33PRx-LM drives are wired for single-phase 120V operation.

Figure 57 - Kinetix 350 Drive (120V Single-phase Input Power)

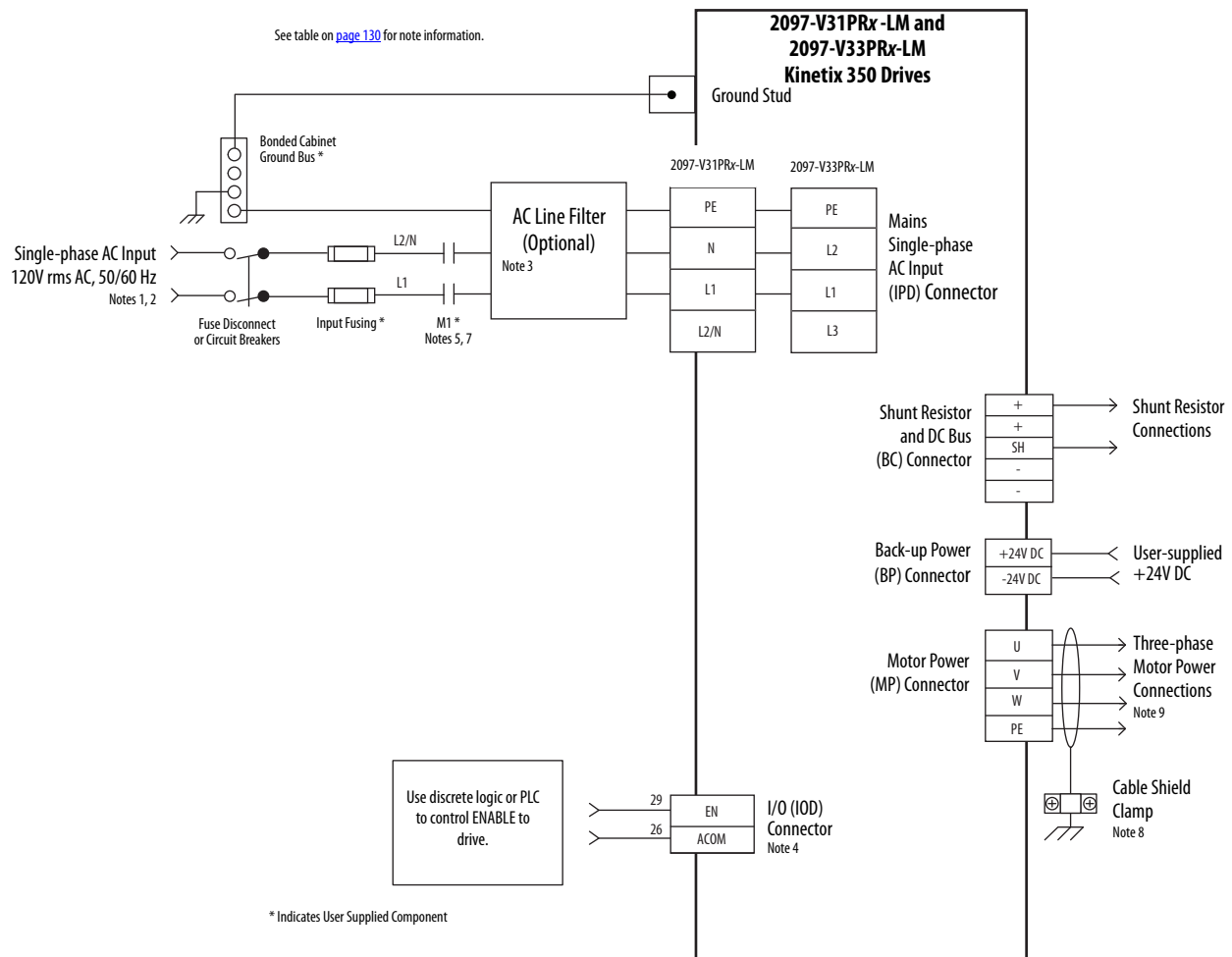

In this example, single-phase 240V AC is applied to 2097-V31PRx-LM and 2097-V32PRx-LM drives.

IMPORTANT The 2097-V32PRx-LM models have integrated AC line filters and do not require the AC line filter that is shown in this diagram.

Figure 58 - Kinetix 350 Drives (240V Single-phase Input Power)

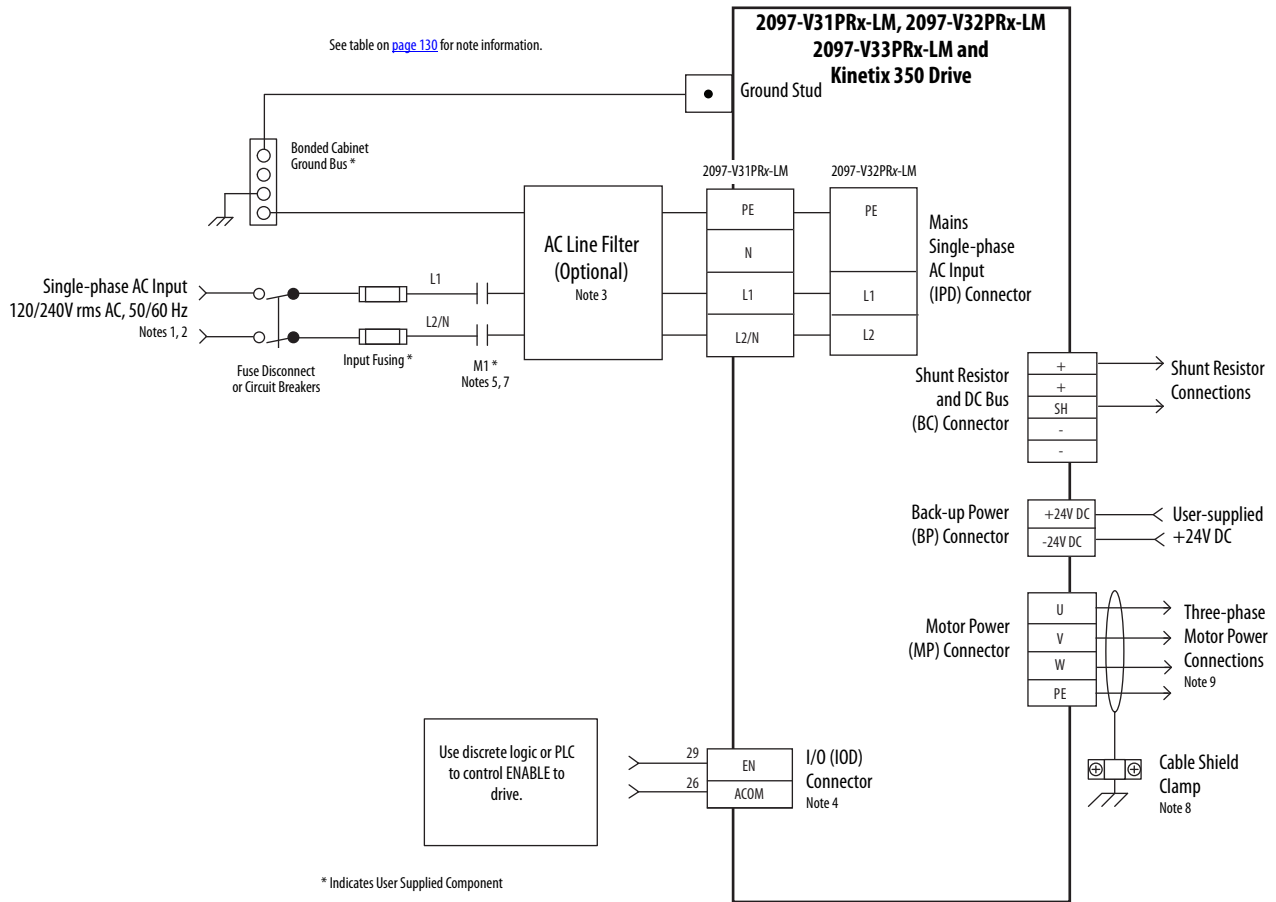

In this example, three-phase 240V AC is applied to 2097-V33PRx-LM drives and 480V AC is applied to 2097-V34PRx-LM drives.

Figure 59 - Kinetix 350 Drive (240/480V three-phase Input Power)

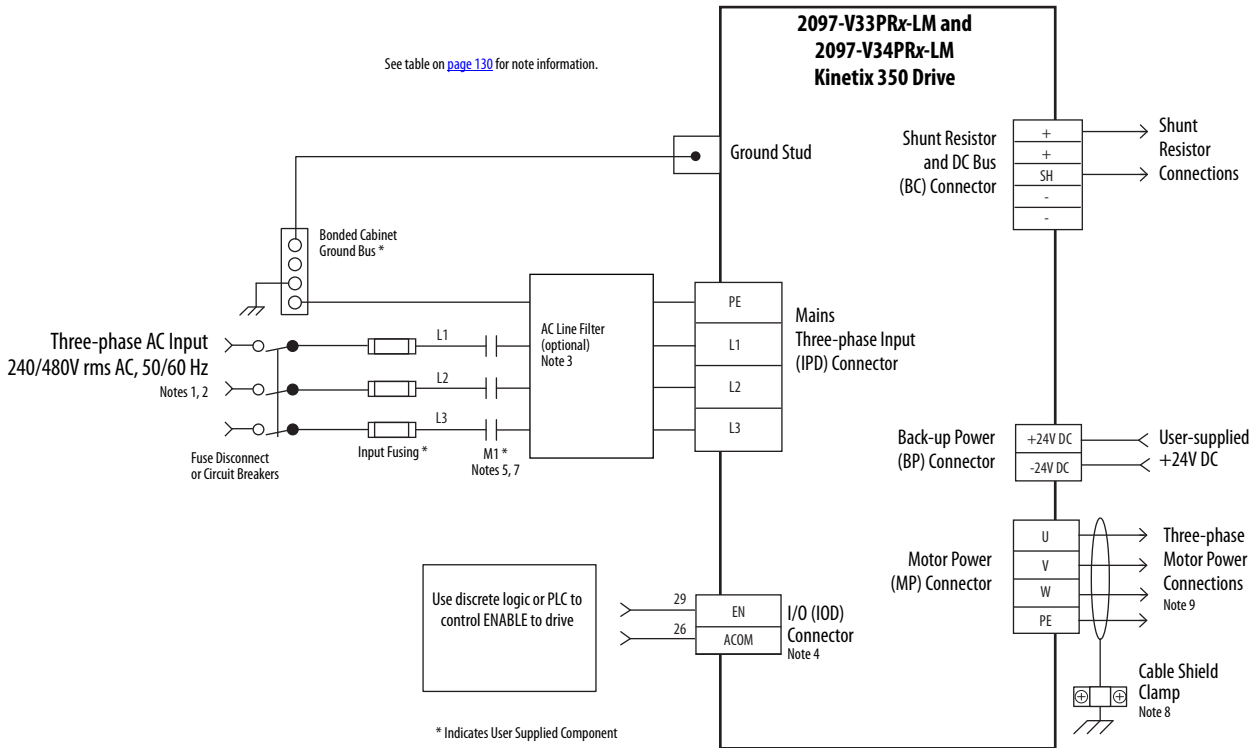

IMPORTANT For the 480V Kinetix 350 drives to meet EN ISO 13849-1 (PLd) spacing requirements, each phase voltage to ground must be less than or equal to 300V AC rms. This requirement means that the power system must use center grounded wye secondary configuration for 400/480V AC mains.

Shunt Resistor Wiring Example

See the Kinetix 350 Drive Power Specifications in Kinetix Servo Drives Specifications Technical Data, publication [KNX-TD003](#) for the Bulletin 2097-Rx shunt resistors available for the Kinetix 350 drives. See the Shunt Resistor Installation Instructions, publication [2097-IN002](#), for additional installation information.

Figure 60 - Shunt Resistor Wiring Example

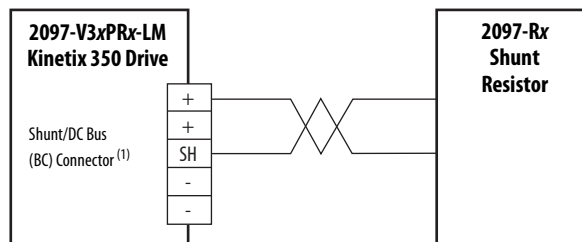

(1) This connector is for the shunt resistor, not the motor brake.

Kinetix 350 Drive/Rotary Motor Wiring Examples

These wiring diagrams apply to Kinetix 350 drives with compatible rotary motors.

IMPORTANT The MP-Series™ motor wiring examples on this page apply to motors equipped with circular DIN (threaded) connectors.

Figure 61 - MP-Series (Bulletin MPL-A/B and MPS-A/B) Motors

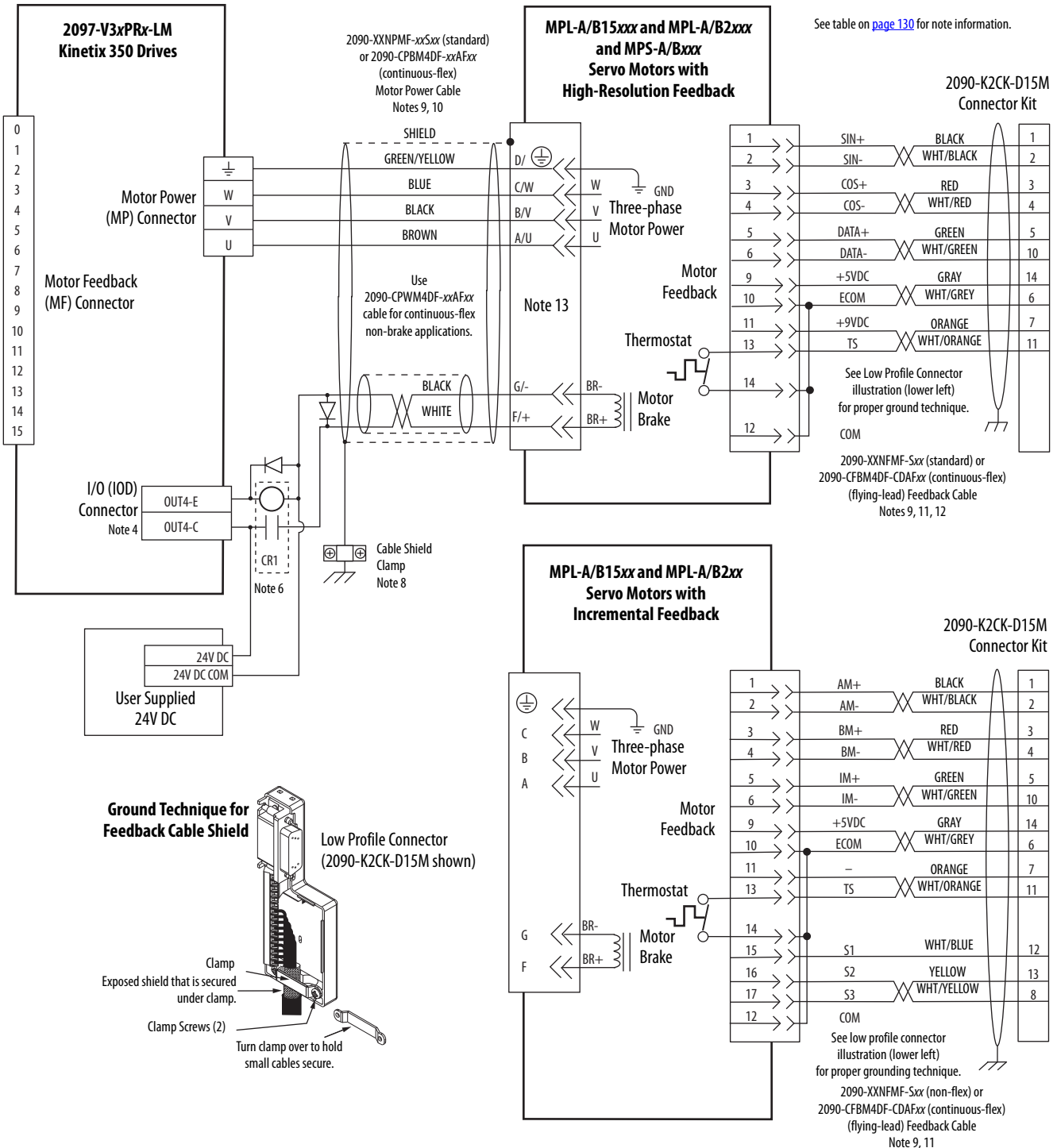

IMPORTANT The MP-Series motor wiring examples on this page apply to motors equipped with circular DIN (SpeedTec) connectors.

Figure 62 - MP-Series (Bulletin MPL-A/B, MPM-A/B, MPF-A/B, and MPS-A/B) Motors

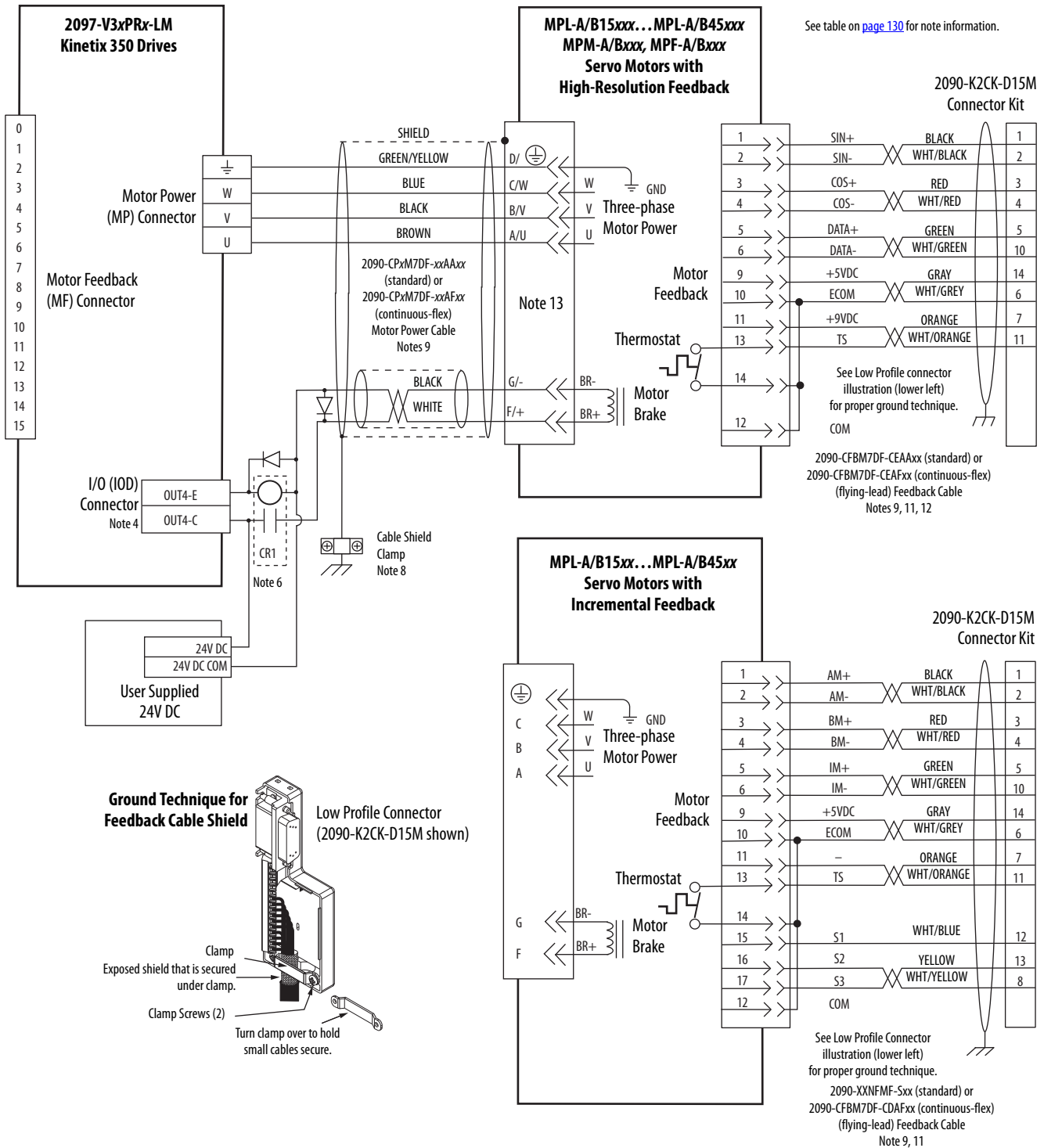
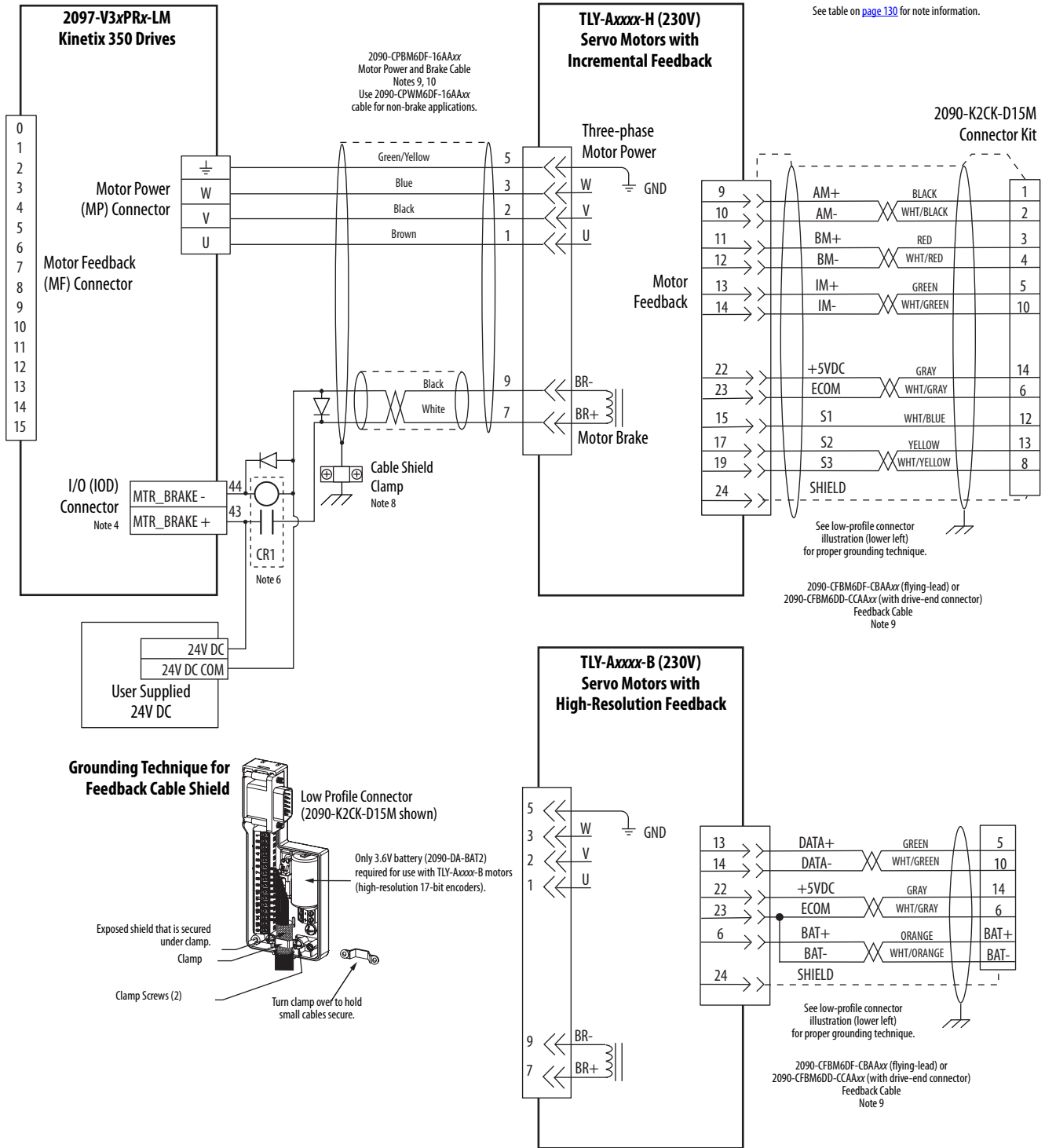
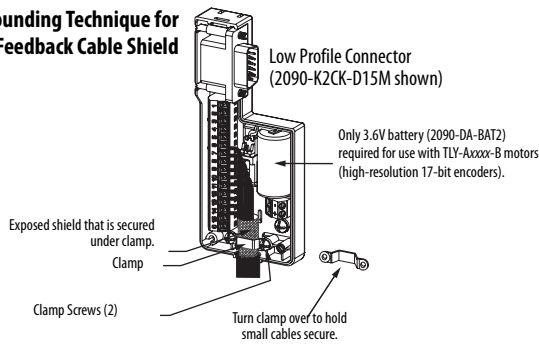

Figure 63 - Kinetix 350 Drive with TL-Series™ (TLY-A) Motors



Grounding Technique for Feedback Cable Shield



Kinetix 350 Drive/Actuator Wiring Examples

These wiring diagrams apply to Kinetix 350 drives with compatible linear actuators.

Figure 64 - Kinetix 350 Drive with MP-Series (Bulletin MPAS-A/B) Linear Stages

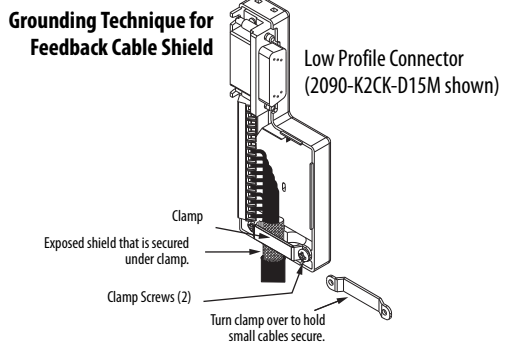
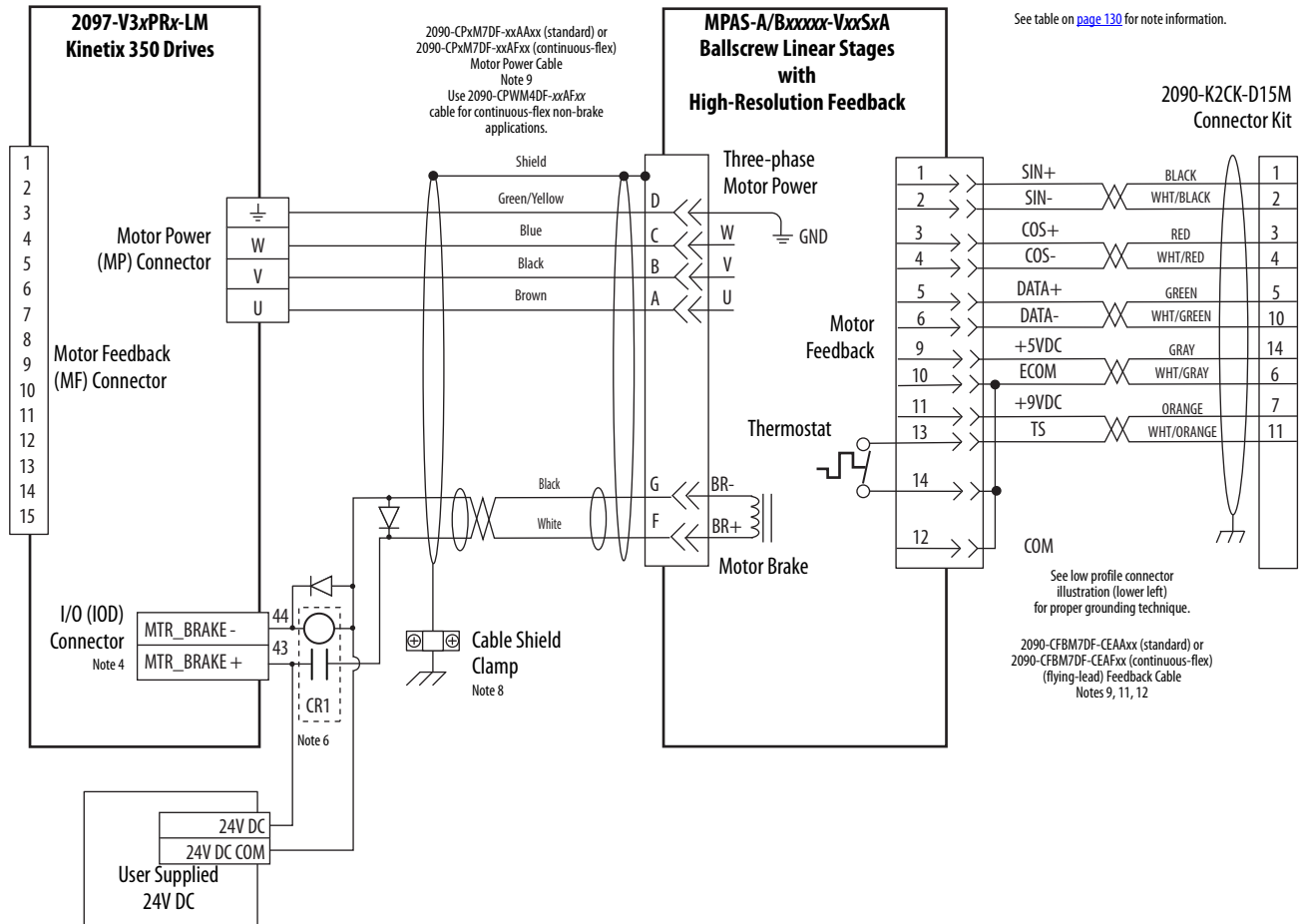

Figure 65 - Kinetix 350 Drive with MP-Series (Bulletin MPAR and MPAI) Electric Cylinders

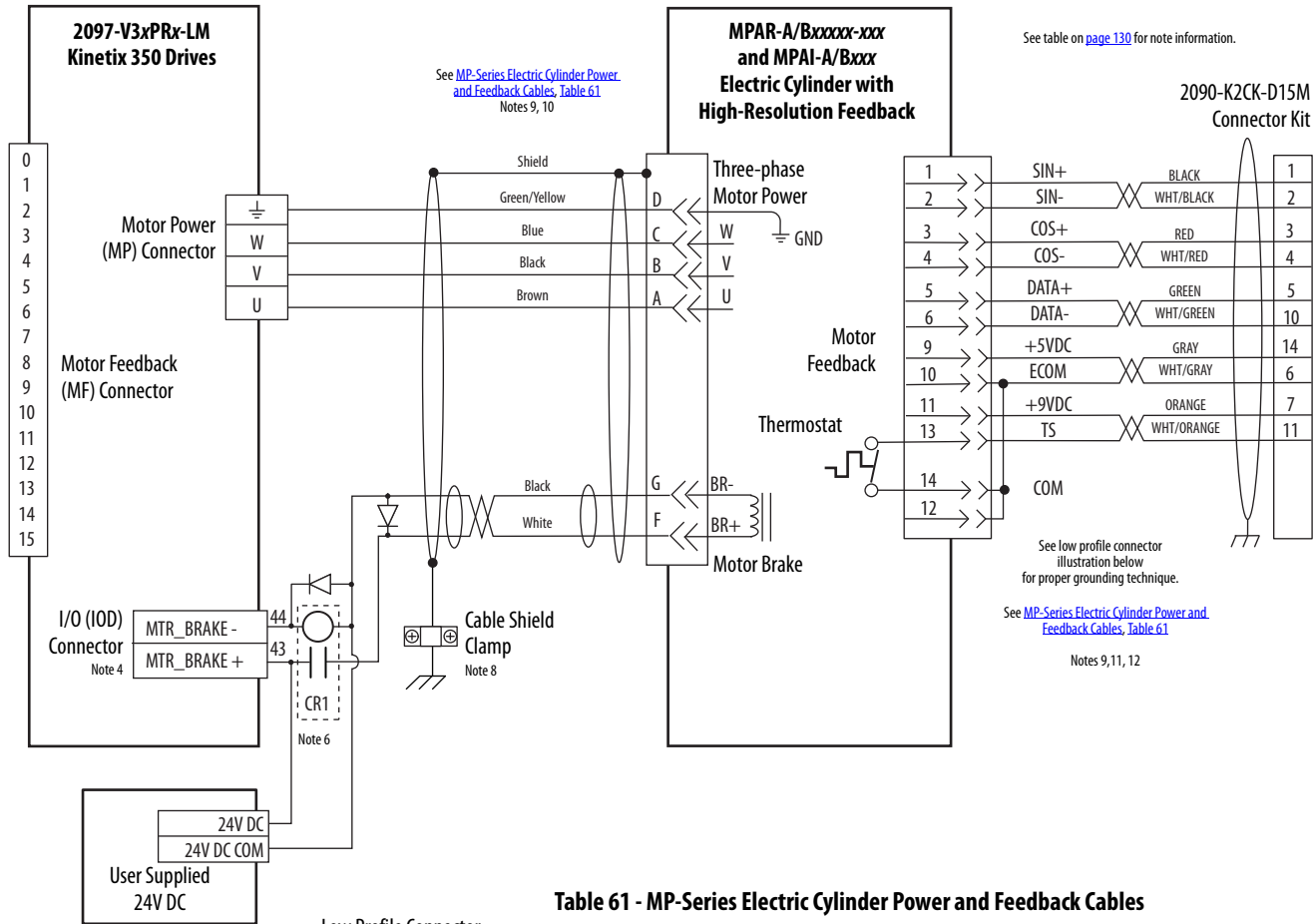

Table 61 - MP-Series Electric Cylinder Power and Feedback Cables

MP-Series Electric Cylinder Cat. No.	Frame	Power Cable Cat. No.	Feedback Cable Cat. No.
MPAR-A/B1xxx (series A)	32	2090-XXNPMF-16Sxx (standard)	2090-XXNFMF-Sxx (standard)
MPAR-A/B2xxx (series A)	40	2090-CPxM4DF-16AFxx (continuous-flex)	2090-CFBM4DF-CDAFxx (continuous-flex)
MPAR-A/B1xxx (series B)	32	2090-CPxM7DF-16AAxx (standard) 2090-CPxM7DF-16AFxx (continuous-flex)	2090-CFBM7DF-CEAAxx (standard) 2090-CFBM7DF-CEAFxx (continuous-flex)
MPAR-A/B2xxx (series B)	40		
MPAR-A/B3xxx	63		
MPAI-A/B2xxxx	64		
MPAI-A/B3xxxx	83		
MPAI-A/B4xxxx	110		
MPAI-B5xxxx			
MPAI-A5xxxx	144	2090-CPxM7DF-14AAxx (standard)	
		2090-CPxM7DF-14AFxx (continuous-flex)	

Grounding Technique for Feedback Cable Shield

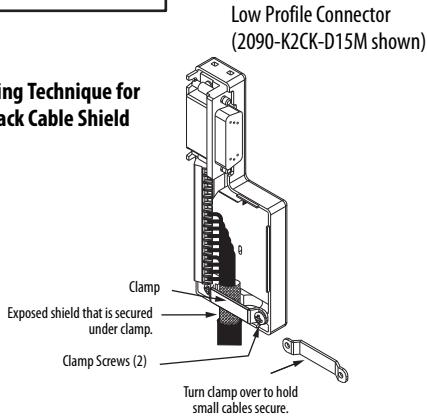
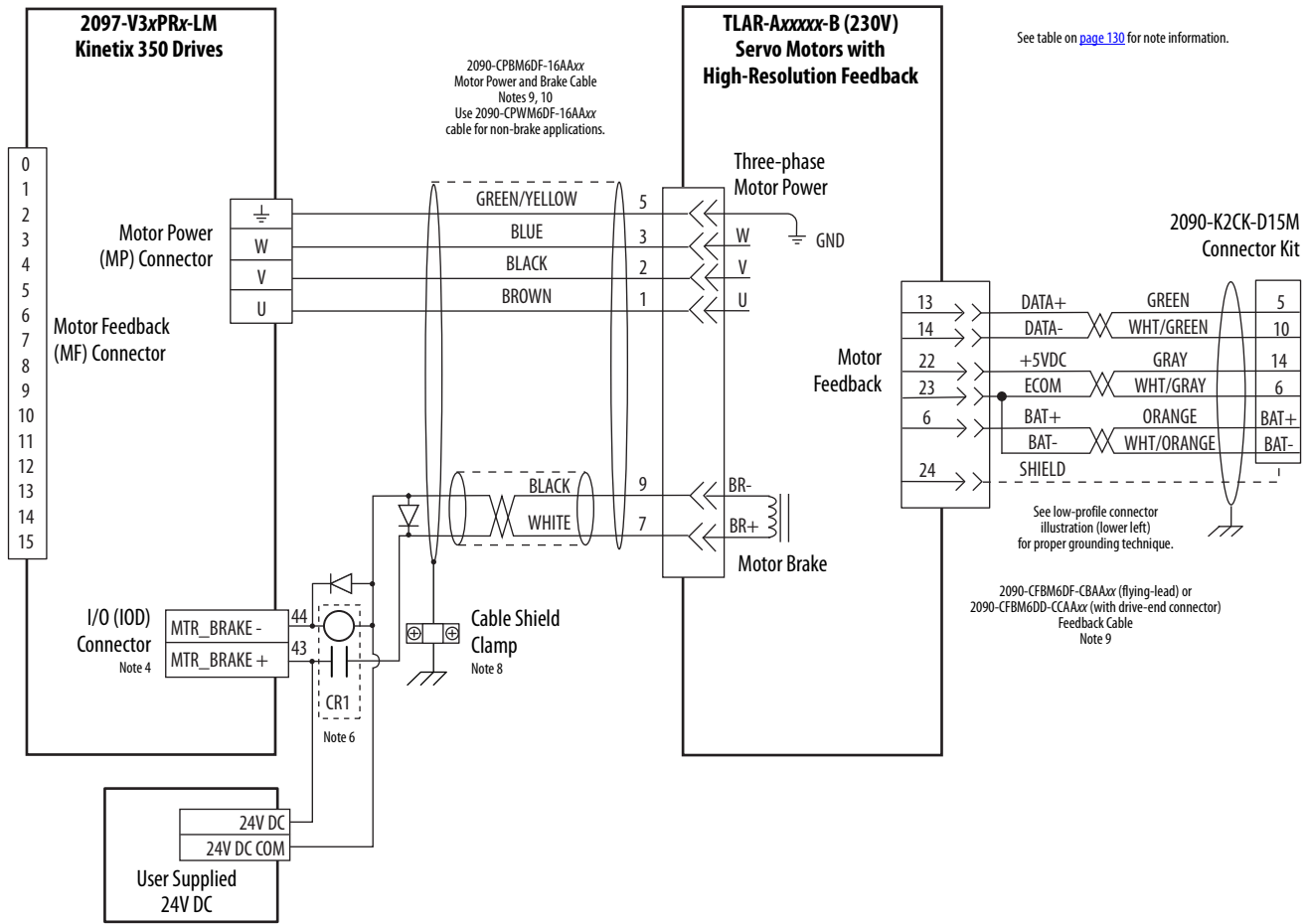
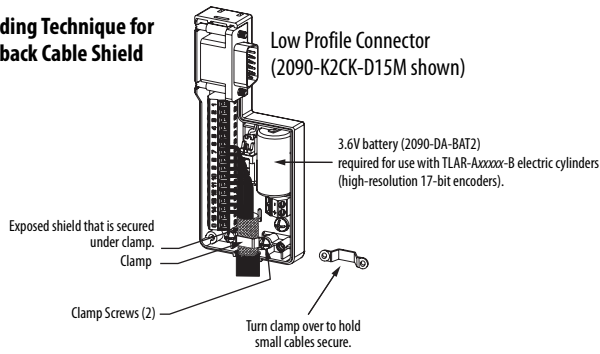

Figure 66 - Kinetix 350 Drive with TL-Series (Bulletin TLAR) Electric Cylinders



Grounding Technique for Feedback Cable Shield



Motor Brake Currents

Use these coil current values to size the interposing relay that is required for your application. See the interconnect diagram for your Kinetix 350 drive/motor beginning on [page 134](#) for typical motor brake circuitry. See Kinetix Rotary Motion Specifications Technical Data, publication [KNX-TD001](#) for more information on Motor Holding brake specifications.

Table 62 - Motor Brake Coil Currents

Compatible Brake Motors/Actuators ⁽¹⁾	Coil Current
MPL-x1510, MPL-x1520, MPL-x1530	0.43...0.53 A
MPL-x210, MPL-x220, MPL-x230	0.46...0.56 A
MPL/MPF-x310, MPL/MPF-x320, MPL/MPF-x330	0.45...0.55 A
MPM-x115	
MPS-x330	
MPL-x420, MPL-x430, MPL-x4520, MPL-x4530, MPL-x4540, MPL-B4560	0.576...0.704 A
MPM-x130	
MPF-x430, MPF-x4530, MPF-x4540	
MPS-x4540	
TLY-A110T, TLY-A120T, and TLY-A130T	0.18...0.22 A
TLY-A220T and TLY-A230T	0.333...0.407 A
TLY-A2530P, TLY-A2540P, and TLY-A310M	0.351...0.429 A

(1) Use of the variable x indicates that this specification applies to 230V and 460V motors.

System Block Diagrams

This power block diagram applies to 2097-V32PRx-LM, 2097-V33PRx-LM, and 2097-V34PRx-LM, servo drives.

Figure 67 - Power Block Diagram

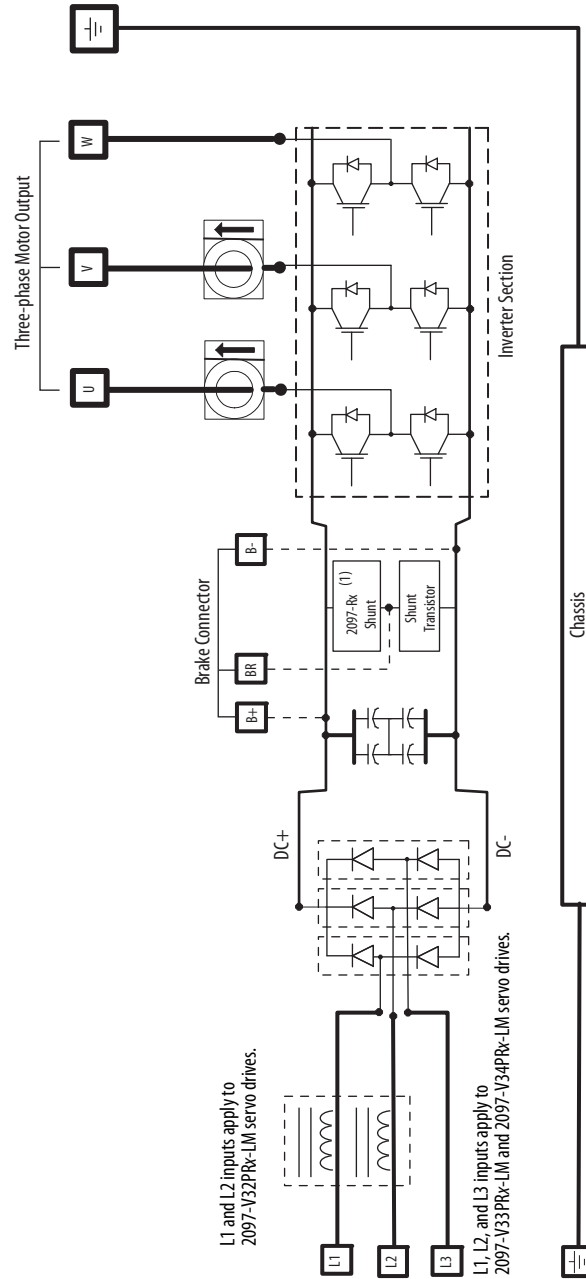

(1) The 2097-Rx shunt module is external to the Kinetix 350 drive.

This power block diagram applies to 2097-V31PRx-LM, servo drives. The voltage-doubler circuitry lets the drives with 120V input power get full performance from 240V motors.

Figure 68 - Voltage Doubler Block Diagram

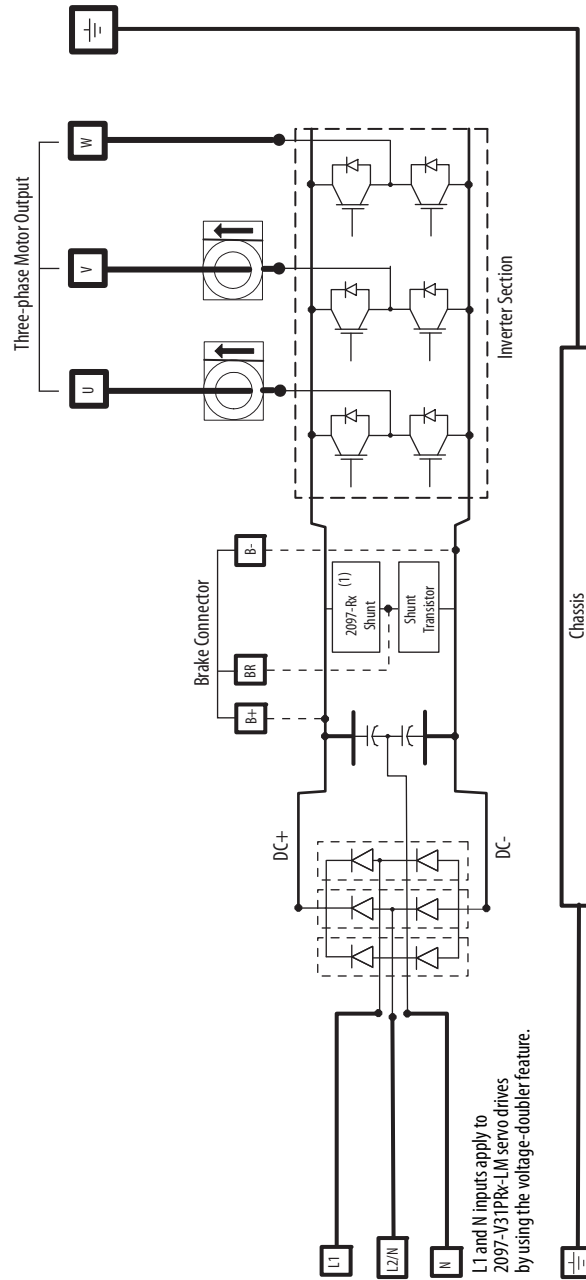

(1) The 2097-Rx shunt module is external to the Kinetix 350 drive.

Upgrade the Kinetix 350 Drive Firmware

Topic	Page
Before You Begin	143
Configure Logix5000 Communication	144
Upgrade Firmware	145
Verify the Firmware Upgrade	149

Upgrading axis module firmware by using ControlFLASH™ software involves configuring your Logix5000™ communication, selecting the drive to upgrade, and upgrading the firmware.

Before You Begin

You need the following software and information before you begin.

Table 67 - Kinetix 350 System Requirements

Description	Cat. No.	Firmware Revision
RSLogix 5000® software or Studio 5000 Logix Designer® application v21 or later	9324-RLD300NE	20.x or later
RSLinx® software		2.58 or later
ControlFLASH firmware upgrade kit ⁽¹⁾		8.00.017 or later
Catalog numbers of the targeted Kinetix® 350 drive you want to upgrade.		
Network path to the targeted Kinetix 350 drive module you want to upgrade.		

(1) Download the ControlFLASH kit from <http://support.rockwellautomation.com/controlflash>. Contact Rockwell Automation Technical Support at (440) 646-5800 for assistance.

For more ControlFLASH information (not drive specific), refer to the ControlFLASH Firmware Upgrade Kit Quick Start, publication [1756-05105](#).

IMPORTANT Input power or back-up power must be present at IPD or BP connector before upgrading your target drive.



ATTENTION: To avoid personal injury or damage to equipment during the firmware upgrade due to unpredictable motor activity, do not apply three-phase AC.

Configure Logix5000 Communication

This procedure assumes that you are communicating to the Logix5000 controller by using the Ethernet protocol. It is also assumed that your Logix5000 Ethernet module has already been configured.

For more information, see the ControlLogix® System User Manual, publication [1756-UM001](#).

Follow these steps to configure Logix5000 communication.

1. Open your RSLinx® Classic software.
2. From the Communications pull-down menu, choose Configure Drivers.

The Configure Drivers dialog box appears.

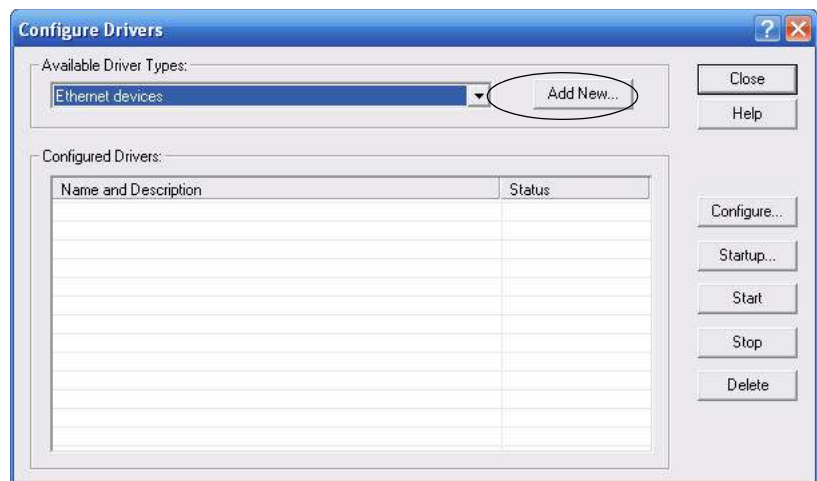

3. From the Available Drive Types pull-down menu, choose Ethernet devices.
4. Click Add New.

The Add New RSLinx Classic Driver dialog box appears.

5. Type the new driver name.



- Click OK.

The Configure driver dialog box appears.

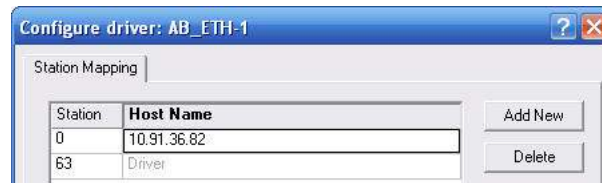

- Type the IP address of your drive.
- Click OK.

The new Ethernet driver appears under Configured Drivers.

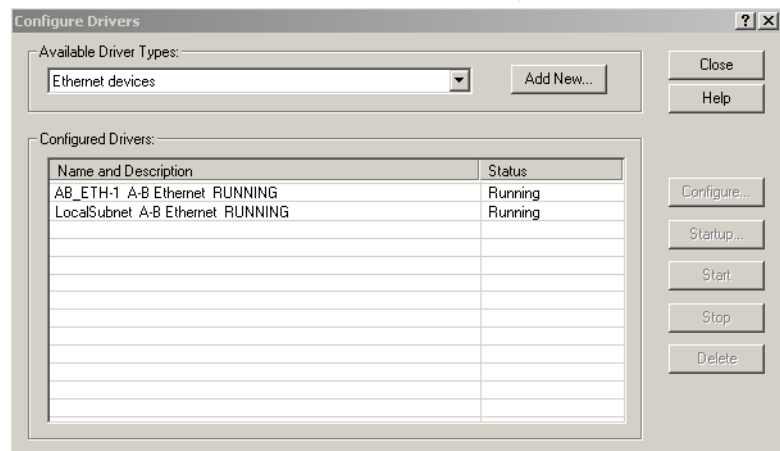

- Click Close.
- Minimize the RSLinx application dialog box.

Upgrade Firmware

Follow these steps to select the drive module to upgrade.

- Open your ControlFLASH software.

You can access the ControlFLASH software by either of these methods:

- In RSLogix 5000® software from the Tools menu, choose ControlFLASH.
- Choose Start>Programs>FLASH Programming Tools>ControlFLASH.

The Welcome to ControlFLASH dialog box appears.



2. Click Next.

The Catalog Number dialog box appears.

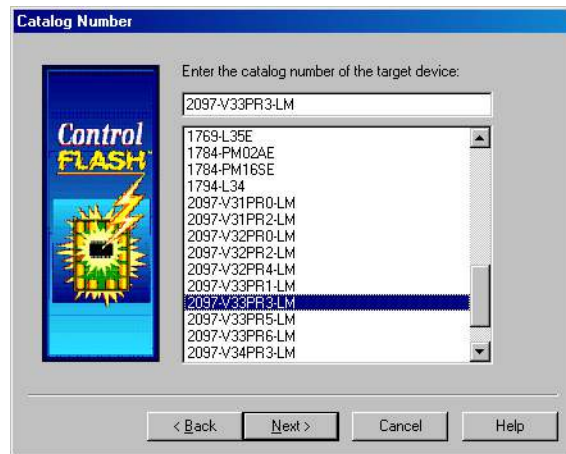

3. Select your drive module and click Next.

The Select Device to Update dialog box appears.

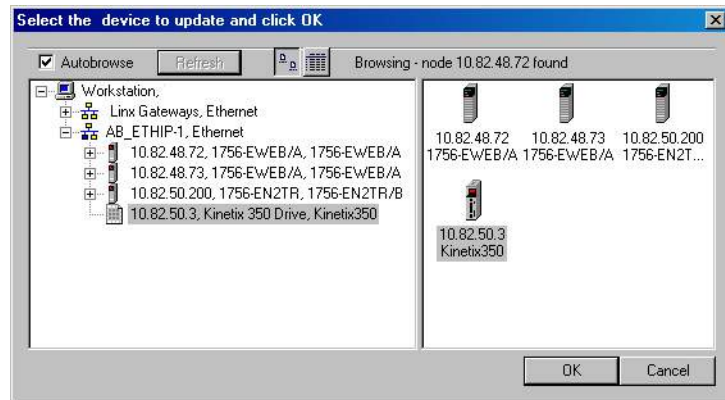

4. Expand your Ethernet node, Logix5000 backplane, and EtherNet/IP network module.
5. Select the servo drive and click OK.

The Firmware Revision dialog box appears.



6. Select the firmware revision and click Next.

The Summary dialog box appears.

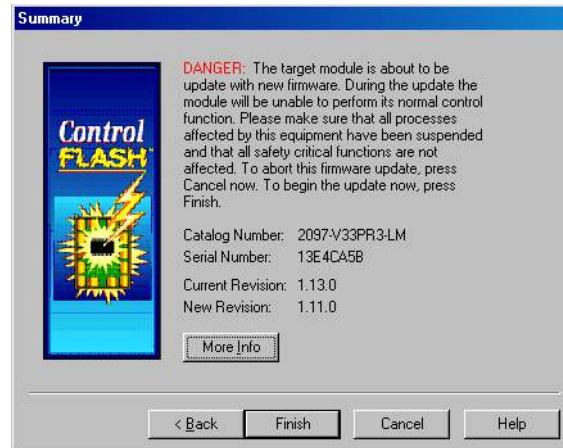

7. Confirm the drive catalog number and firmware revision and click Finish

This ControlFLASH warning dialog box appears.



8. Click Yes (when ready).

The Progress dialog box appears and upgrading begins.

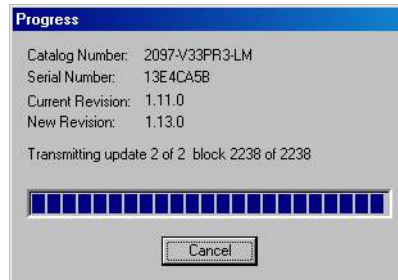

The drive four-digit status indicator changes to -PS- and scrolls IP address, which indicates that upgrading is in progress.

After the upgrade information is sent to the drive, the drive resets and performs diagnostic check-in, then it displays 350, -08-, and scrolls -00- and the IP address.

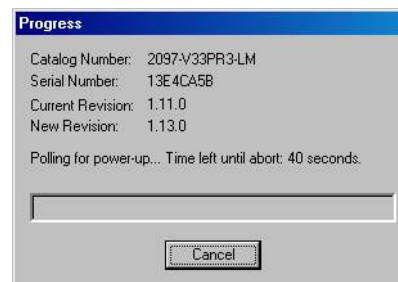

9. Wait for the Progress dialog box to time out.

It is normal for this process to take several minutes.

IMPORTANT Do not cycle power to the drive during this process or the firmware upgrade is not completed successfully.

10. The Update Status dialog box appears and indicates success or failure as described here.

Upgrading Status	If
Success	<ol style="list-style-type: none"> 1. Update complete appears in a GREEN Status dialog box. 2. Go to step 11.
Failure	<ol style="list-style-type: none"> 1. Update failure appears in a RED Status dialog box. 2. See ControlFLASH Firmware Upgrade Kit Quick Start, publication 1756-QS105, for troubleshooting information.



11. Click OK.

Verify the Firmware Upgrade

Follow these steps to verify that your firmware upgrade was successful.

TIP Verifying that the firmware upgrade is optional.

Open your RSLinx software.

12. From the Communications pull-down menu, choose RSWho.

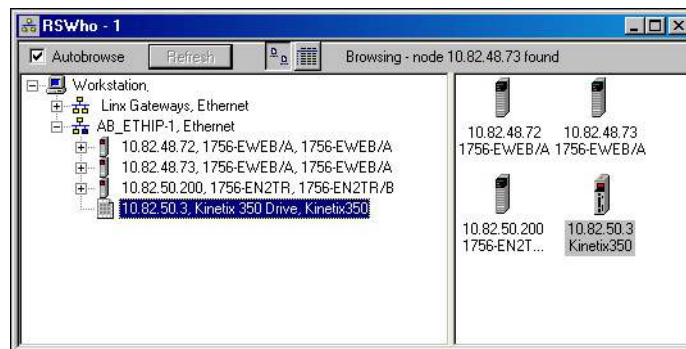

13. Expand your Ethernet node, Logix5000 backplane, and EtherNet/IP network module.
14. Right-click the drive module and choose Device Properties.

The Device Properties dialog box appears.



15. Verify the new firmware revision level.
16. Click Close.

Leakage Current Specifications

This appendix contains a table of the leakage currents to be expected for center, wye, and delta corner-grounded Kinetix® 350 drives used with or without mains filters.

Table 68 - Leakage Current Specifications

Catalog No.	Drive Description	AC Input Voltage (rms)	Continuous Output Current (rms)	Number of Phases	Mains Input - Nominal Line Typical Leakage (Calculated)			Mains Input - High Line (Nominal +10%) Fault Leakage (Calculated)		
					Center Ground WYE		Corner Ground Delta	Center Ground WYE		Corner Ground Delta
					Single-phase	Three-phase	Corner Ground Delta	Single-phase	Three-phase	Corner Ground Delta
2097-V31PR0-LM	120/240V, single-phase, doubler	120V	2 A	1	No External Filter	7 mA pk	No External Filter	7 mA pk	No External Filter	7 mA pk
		240V			7 mA pk	7 mA pk	8 mA pk			
		120V	4 A		6 mA pk	7 mA pk	7 mA pk	7 mA pk		
		240V			7 mA pk	8 mA pk	8 mA pk			
2097-V32PR0-LM	208/240V single-phase, with integrated filter	240V	2 A	1	No External Filter	27 mA pk	No External Filter	29 mA pk	No External Filter	29 mA pk
			4 A		26 mA pk	28 mA pk	28 mA pk			
			8 A		26 mA pk	29 mA pk	29 mA pk			
2097-V33PR1-LM	208/240V, single/three-phase	240V	2 A	3	No External Filter	18 mA pk	No External Filter	20 mA pk	No External Filter	20 mA pk
					2 mA pk	2 mA pk	2 mA pk	2 mA pk		
					1 mA pk	1 mA pk	1 mA pk	1 mA pk		
2097-V33PR3-LM	208/240V, single/three-phase	240V	4 A	1	No External Filter	18 mA pk	No External Filter	19 mA pk	No External Filter	19 mA pk
					2 mA pk	2 mA pk	3 mA pk	3 mA pk		
					1 mA pk	1 mA pk	1 mA pk	1 mA pk		
2097-V33PR5-LM	208/240V, single/three-phase	240V	8 A	3	No External Filter	17 mA pk	No External Filter	19 mA pk	No External Filter	19 mA pk
					2 mA pk	2 mA pk	3 mA pk	3 mA pk		
					2 mA pk	2 mA pk	2 mA pk	2 mA pk		
2097-V33PR6-LM	208/240V, single/three-phase	240V	12 A	1	No External Filter	19 mA pk	No External Filter	20 mA pk	No External Filter	20 mA pk
					3 mA pk	3 mA pk	3 mA pk	3 mA pk		
					12 mA pk	12 mA pk	13 mA pk	13 mA pk		

Notes:

Numerics

- 120/240V single-phase input power** 132
- 120V single-phase input power** 131
- 240/480V three-phase input power** 133

A

- AC input power**
 - pinouts 38
- actions tab** 91
- actuators**
 - interconnect diagram
 - MPAI 138
 - MPAR 138
 - MPAS 137
 - TLAR 139
- additional resources** 9
- application**
 - Logix Designer 84
- apply power** 93
- axis module**
 - axis properties 90
 - status indicators 119
- axis unstable** 120

B

- back-up power** 43
 - pinouts 38
- block diagrams**
 - power block diagram 141
 - voltage-doubler block diagram 142
- bond** 25
 - EMI (electromagnetic interference) 24
 - high frequency energy 26
 - subpanels 26
- brake currents** 140
- build your own cables** 52

C

- cables**
 - build your own cables 52
 - Ethernet cable length 75
 - length, CE 18
 - motor feedback 70
 - motor power 65
 - shield clamp 69
- catalog numbers** 15
- category 3**
 - requirements 102
 - stop category definitions 102
- CE**
 - compliance 16, 57
 - comply with CE 105
 - conformity 105
 - meet requirements 105

certification

- TÜV Rheinland 101
- user responsibilities 101

circuit breaker

- selection 18

circuit breaker specifications

- Kinetix 350 19

clamp

- 69

clean zone

- 27

clearance requirements

- 23

configure

- axis properties 90
- delay times 92
- drive modules 87
- EtherNet/IP controller 84

connect

- Ethernet 74
- external shunt resistor 74
- feedback 70
- I/O 70
- motor shield clamp 69

connector

- designators 34
- locations 34, 104

contactor specifications

ControlFLASH

- firmware upgrade 143
- troubleshooting 149
- verify upgrade 149

controller properties

- 85

conventions used in this manual

- 9

D

data type

- 88

date/time tab

- 85

delay times

- 92

digital inputs

- 39

dirty zone

- 27

download program

- 93

drive

- wire BP connector 62
- wire IPD connector 63
- wire MP connector 64
- wire STO connector 62
- wiring requirements 60

drive status indicator

- 120

E

EMC

- directive 105
- motor ground termination 64
- motor ground termination at motor 64

EMI (electromagnetic interference)

- bonding 24

EN 61508

- 102

EN 62061

- 102

EN ISO 13849-1 CAT 3

- requirements 102
- stop category definitions 102

enable time synchronization 85**enableInputChecking 95, 100****enclosure**

- requirements 17
- sizing 21

erratic operation 123**Ethernet**

- cable length 75
- cables
 - RJ45 connector 74
- pinouts 37
- wiring 74

F**fault code summary 113****fault codes 113****fault status only 124****feedback connections 70****feedback power supply 49****firmware upgrade 143**

- verify upgrade 149

fuse

- selection 18

fuse specifications

- Kinetix 350 19

G**generic TTL incremental 44****ground**

- multiple subpanels 59
- system to subpanel 58

grounded power configuration 53**H****hardware enable input 95, 98****HF bonding 24****high frequency energy 26****hookup test 95****I****I/O**

- specifications 39

I/O connections 70**I/O connector wiring 72****I/O specifications**

- back-up power 43
- pinouts 36

input power wiring

- 3-phase Delta 53
- 3-phase WYE 53
- determine input power 52
- grounded power configuration 53
- single-phase 54
 - voltage doubler 54
- single-phase amplifiers on 3-phase power 55, 56

install drive accessories

- I/O terminal block 72
- low-profile connector kits 73
- shunt resistor 74

install your drive

- bond subpanels 26
- circuit breakers 18
- fuse selection 18
- HF bonding 24
- system mounting requirements 17
- transformer 20

integrated axis module

- axis properties 90
- status indicators 119

interconnect diagrams

- 120/240V single-phase input power 132
- 120V single-phase input power 131
- 2097 with MPAL actuator 138
- 2097 with MPAR actuator 138
- 2097 with MPAS actuator 137
- 2097 with MPL/MPM/MPF/MPS motor 134
- 2097 with TLAR actuator 139
- 2097 with TLY motor 136
- 240/480V three-phase input power 133
- notes 130
- shunt resistor 133

interpreting status indicators 112**K****Kinetix 350**

- specifications
 - circuit breaker/fuse 19

L**Logix Designer application 84****low profile connector kits**

- wiring 73

low voltage directive 105**M****module properties**

- drive modules 87

motion group properties 89**motor feedback**

- pinouts 37
- specifications
 - general 44
 - thermostat 45
- wiring 70

motor power

- pinouts 38
- wiring 65

motor tab 90**motors**

- accel/decel problems 121, 122
- brake currents 140
- feedback pinouts 71
- ground termination 64
- interconnect diagram
 - MPL/MPM/MPF/MPS 134
 - TLY 136
- overheating 121, 122
- power wiring
 - 3-phase and brake 67
 - 3-phase only 66
 - TL-Series 65
- shield clamp wiring 69
- test 94
- tune 94
- velocity 121, 122

mount

- Kinetix 350 drive 32

MSG instruction 100**N****network status indicator** 120**noise** 27

- abnormal 123
- feedback 121, 122

P**panel**

- requirements 17

parameters 92**PFD and PFH data** 103**PFD and PFH definition** 103**pinouts**

- AC input power (IPD) 38
- back-up power (BP) 38
- Ethernet (Port 1) 37
- I/O (IOD) 36
- motor feedback (MF) 37
- motor feedback connector 71
- motor power (MP) 38
- safe torque-off (STO) 35
- shunt resistor and DC bus (BC) 38

PORT 1 status indicator 120**power block diagram** 141**power supply, feedback** 49**powerup** 93**publications, related** 9**R****related publications** 9**requirements**

- clearance 23

RJ45

- Ethernet connector 74

route power and signal wiring 52**RSLogix 5000 software** 12**S****safe torque-off**

- bypass 107
- connector location 104
- operation 102, 107
- PFD and PFH data 103
- PFD and PFH definition 103
- pinouts 35
- specifications 109
- troubleshooting 103
- wiring diagram 108
- wiring requirements 106

safety products catalog 108**shield clamp** 69**shunt resistor** 30

- interconnect diagram 133
- wiring requirements 74

shunt resistor and DC bus

- pinouts 38

shunt/DC bus connector 74**shutdown** 124**software**

- Logix Designer application 12
- RSLogix 5000 12

specifications

- back-up power 43
- contactor ratings 20
- digital inputs 39
- feedback
 - power supply 49
- Kinetix 350
 - circuit breaker/fuse 19
- motor feedback 44
 - generic TTL 47
 - Stegmann 46
 - Tamagawa 48
- motor thermostat interface 45
- safe torque-off 109
- transformer 21

status indicators 112, 119

- drive status 120
- PORT 1 status 120

Stegmann 44**stop drive** 124**stop planner** 124**Studio 5000 environment** 84**Studio 5000 Logix Designer** 12**system block diagrams**

- power block diagram 141
- voltage-doubler block diagram 142

system mounting requirements 17**system overview** 12

- diagram 13

T**Tamagawa** 44**test axes**

hookup test 95

transformer

sizing 20

specifications 21

troubleshooting 120

ControlFLASH 149

drive status indicator 120

exception behavior 124

fault code summary 113

fault codes 113

fault status only 124

four-digit display messages 112

general system problems 120

abnormal noise 123

axis unstable 120

erratic operation 123

feedback noise 121, 122

motor accel/decel 121, 122

motor overheating 121, 122

motor velocity 121, 122

no rotation 121, 122

Logix/drive fault behavior 124

network status indicator 120

PORT 1 status indicator 120

safe torque-off 103

safety precautions 111

shutdown 124

stop drive 124

stop planner 124

tune axes

autotune tab 97

determine type 52
low profile connectors 73
motor cable shield clamp 69
motor feedback 70
motor power 65, 66, 67
requirements 51, 106
drive 60
shunt resistor 74
route power and signal wiring 52
shunt resistor 74

V**voltage doubler**

block diagram 142

operation 54

power diagram 131

W**wiring**

build your own cables 52

diagram, safe torque-off 108

drive

BP connector 62

IPD connector 63

MP connector 64

STO connector 62

Ethernet connections 74

grounded power configuration 53

grounding drive 58

guidelines 61

I/O connector 72

input power

Notes:

Rockwell Automation Support

Use the following resources to access support information.

Technical Support Center	Knowledgebase Articles, How-to Videos, FAQs, Chat, User Forums, and Product Notification Updates.	https://rockwellautomation.custhelp.com/
Local Technical Support Phone Numbers	Locate the phone number for your country.	http://www.rockwellautomation.com/global/support/get-support-now.page
Direct Dial Codes	Find the Direct Dial Code for your product. Use the code to route your call directly to a technical support engineer.	http://www.rockwellautomation.com/global/support/direct-dial.page
Literature Library	Installation Instructions, Manuals, Brochures, and Technical Data.	http://www.rockwellautomation.com/global/literature-library/overview.page
Product Compatibility and Download Center (PCDC)	Get help determining how products interact, check features and capabilities, and find associated firmware.	http://www.rockwellautomation.com/global/support/pcdc.page

Documentation Feedback

Your comments will help us serve your documentation needs better. If you have any suggestions on how to improve this document, complete the How Are We Doing? form at http://literature.rockwellautomation.com/idc/groups/literature/documents/du/ra-du002_-en-e.pdf.

Rockwell Automation maintains current product environmental information on its website at <http://www.rockwellautomation.com/rockwellautomation/about-us/sustainability-ethics/product-environmental-compliance.page>.

Allen-Bradley, CompactLogix, ControlFLASH, ControlLogix, Kinetix, Logix5000, Logix PAC, MP-Series, Rockwell Automation, Rockwell Software, RSLogix 5000, Stratix 2000, Studio 5000, Studio 5000 Logix Designer, and TL-Series are trademarks of Rockwell Automation, Inc.

Trademarks not belonging to Rockwell Automation are property of their respective companies.

Rockwell Otomasyon Ticaret A.Ş., Kar Plaza İş Merkezi E Blok Kat:6 34752 İçerenköy, İstanbul, Tel: +90 (216) 5698400

www.rockwellautomation.com

Power, Control and Information Solutions Headquarters

Americas: Rockwell Automation, 1201 South Second Street, Milwaukee, WI 53204-2496 USA, Tel: (1) 414.382.2000, Fax: (1) 414.382.4444

Europe/Middle East/Africa: Rockwell Automation NV, Pegasus Park, De Kleetlaan 12a, 1831 Diegem, Belgium, Tel: (32) 2 663 0600, Fax: (32) 2 663 0640

Asia Pacific: Rockwell Automation, Level 14, Core F, Cyberport 3, 100 Cyberport Road, Hong Kong, Tel: (852) 2887 4788, Fax: (852) 2508 1846

Rockwell Automation Publication 2097-UM002D-EN-P - April 2017

Supersedes Publication 2097-UM002C-EN-P - December 2013

Copyright © 2017 Rockwell Automation, Inc. All rights reserved. Printed in the U.S.A.