

MODEL W1819/W1820 10" CABINET SAW



OWNER'S MANUAL

(FOR MODELS MANUFACTURED SINCE 12/10)

Phone: (360) 734-3482 • Online Technical Support: tech-support@shopfox.biz



COPYRIGHT © JULY, 2010 BY WOODSTOCK INTERNATIONAL, INC. REVISED MARCH, 2011 (BL)

WARNING: NO PORTION OF THIS MANUAL MAY BE REPRODUCED IN ANY SHAPE OR FORM WITHOUT

THE WRITTEN APPROVAL OF WOODSTOCK INTERNATIONAL, INC.

#13060TRBLTSJB Printed in China

WARNING!

This manual provides critical safety instructions on the proper setup, operation, maintenance, and service of this machine/tool. Save this document, refer to it often, and use it to instruct other operators.

Failure to read, understand and follow the instructions in this manual may result in fire or serious personal injury—including amputation, electrocution, or death.

The owner of this machine/tool is solely responsible for its safe use. This responsibility includes but is not limited to proper installation in a safe environment, personnel training and usage authorization, proper inspection and maintenance, manual availability and comprehension, application of safety devices, cutting/sanding/grinding tool integrity, and the usage of personal protective equipment.

The manufacturer will not be held liable for injury or property damage from negligence, improper training, machine modifications or misuse.

WARNING!

Some dust created by power sanding, sawing, grinding, drilling, and other construction activities contains chemicals known to the State of California to cause cancer, birth defects or other reproductive harm. Some examples of these chemicals are:

- Lead from lead-based paints.
- Crystalline silica from bricks, cement and other masonry products.
- Arsenic and chromium from chemically-treated lumber.

Your risk from these exposures varies, depending on how often you do this type of work. To reduce your exposure to these chemicals: Work in a well ventilated area, and work with approved safety equipment, such as those dust masks that are specially designed to filter out microscopic particles.

Contents

INTRODUCTION	2	Blade Tilt & Bevel Cuts.....	43
Woodstock Technical Support	2	Dado Cutting	44
Controls and Features	3	Rabbet Cutting	47
Model W1819 Specifications	4	Resawing.....	49
Model W1820 Specifications	7	Table Saw Accessories	53
SAFETY	10	SHOP-MADE SAFETY ACCESSORIES	55
Standard Machinery Safety Instructions	10	Featherboards	55
Additional Safety for Table Saws	12	Push Sticks	58
Preventing Kickback	13	Push Blocks.....	59
Protecting Yourself From Kickback	13	Narrow-Rip Auxiliary Fence & Push Block..	60
Glossary of Terms	14	Outfeed & Support Tables	62
ELECTRICAL	15	Crosscut Sled.....	62
Circuit Requirements	15	MAINTENANCE	63
Grounding Requirements.....	16	Schedule	63
Extension Cords	16	Cleaning	63
SETUP	17	Lubrication	64
Unpacking	17	SERVICE	65
Items Needed for Setup.....	17	General	65
Inventory	18	Blade Tilt Stops.....	65
Fence Inventory W1819	19	Miter Slot to Blade Parallelism.....	67
Fence Inventory W1820	20	Spreader or Riving Knife Alignment	68
Machine Placement	21	Fence Adjustments.....	70
Cleaning Machine.....	21	Fence Scale Calibration	72
Assembly.....	22	Miter Gauge Adjustments	73
Dust Collection	29	Belt Tension & Replacement	74
Test Run.....	30	Electrical Safety Instructions.....	75
OPERATIONS	31	Model W1819/W1820 Wiring Diagram.....	76
General	31	Troubleshooting.....	77
Basic Controls.....	31	PARTS	79
Non-Through & Through Cuts	32	Body	79
Blade Selection	33	Trunnion	81
Blade Installation	35	Blade Guard	84
Blade Guard Assembly	36	Miter Gauge	85
Riving Knife	38	Fence.....	86
Workpiece Inspection.....	39	W1819 Extension Wing & Rails	87
Ripping	40	W1820 Extension Wing & Rails	88
Crosscutting.....	41	Machine Labels	89
Miter Cuts	42	WARRANTY	93
Miter Fence	42		
Flip Stop	43		

USE THE QUICK GUIDE PAGE LABELS TO SEARCH OUT INFORMATION FAST!





INTRODUCTION

Woodstock Technical Support

This machine has been specially designed to provide many years of trouble-free service. Close attention to detail, ruggedly built parts and a rigid quality control program assure safe and reliable operation.

Woodstock International, Inc. is committed to customer satisfaction. Our intent with this manual is to include the basic information for safety, setup, operation, maintenance, and service of this product.

We stand behind our machines! In the event that questions arise about your machine, please contact Woodstock International Technical Support at (360) 734-3482 or send e-mail to: tech-support@shopfox.biz. Our knowledgeable staff will help you troubleshoot problems and process warranty claims.

If you need the latest edition of this manual, you can download it from <http://www.shopfox.biz>.
If you have comments about this manual, please contact us at:

Woodstock International, Inc.
Attn: Technical Documentation Manager
P.O. Box 2309
Bellingham, WA 98227
Email: manuals@woodstockint.com

Controls and Features

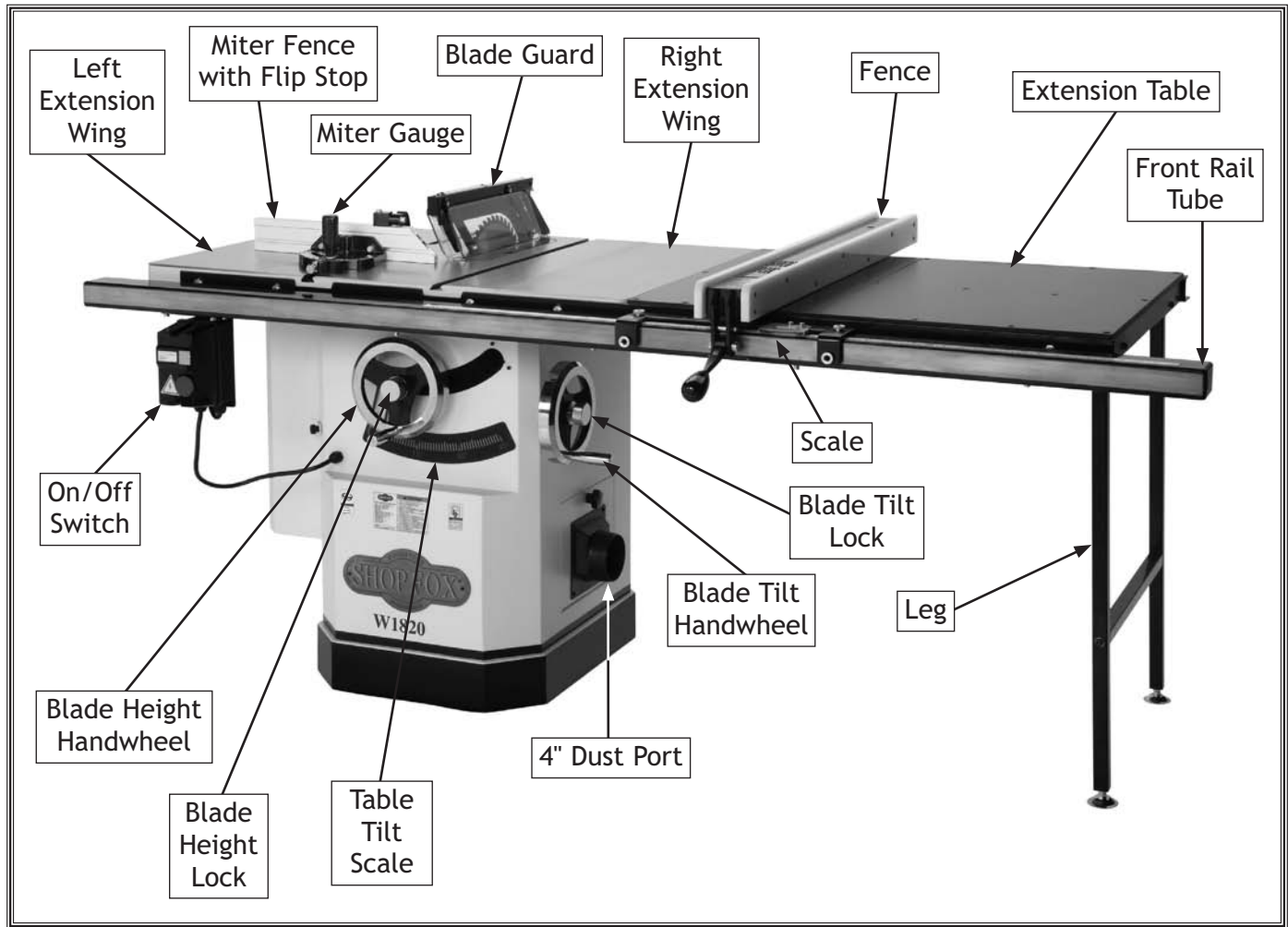

Figure 1. Identification (Model W1820 shown).



MACHINE SPECIFICATIONS



© Woodstock International, Inc. • Phone: (800) 840-8420 • Web: www.shopfox.biz

MODEL W1819 SHOP FOX® CABINET SAW W/ RIVING KNIFE

Product Dimensions

Weight..... 507 lbs.
 Width (side-to-side) x Depth (front-to-back) x Height..... 62 x 45-1/2 x 40 in.
 Footprint (Length x Width)..... 22-1/4 x 20 in.

Shipping Dimensions

Carton #1

Type..... Cardboard/Wood Skids
 Content..... Machine & Table Extension
 Weight..... 463 lbs.
 Length x Width x Height..... 33 x 30 x 40 in.

Carton #2

Type..... Cardboard
 Content..... Fence
 Weight..... 27 lbs.
 Length x Width x Height..... 42 x 17 x 7 in.

Carton #3

Type..... Cardboard
 Content..... Rails
 Weight..... 49 lbs.
 Length x Width x Height..... 68 x 7 x 5 in.

Electrical

Power Requirement..... 220-240V, Single-Phase, 60 Hz
 Minimum Circuit Size..... 20A
 Switch..... Magnetic with Thermal Overload Protection
 Switch Voltage..... 220V
 Cord Length..... 6 feet
 Cord Gauge..... 14 gauge
 Plug Included..... Yes
 Included Plug Type..... 6-20

Motors

Main

Type.....	TEFC Capacitor Start Induction
Horsepower.....	3 HP
Voltage.....	230V
Phase.....	Single
Amps.....	12.8A
Speed.....	3450 RPM
Cycle.....	60 Hz
Number of Speeds.....	1
Power Transfer	Triple V-Belt Drive
Bearings.....	Shielded and Permanently Sealed

Main Specifications

Blade Information

Maximum Blade Diameter.....	10 in.
Riving Knife/Spreader Thickness.....	0.1 in. (2.5mm)
Required Blade Body Thickness.....	0.071-0.094 in. (1.8-2.4mm)
Required Blade Kerf Thickness.....	0.102-0.126 in. (2.6-3.2mm)
Maximum Width of Dado.....	13/16 in.
Blade Tilt.....	Left 0-45 deg.
Arbor Size.....	5/8 in.
Arbor Speed.....	4300 RPM
Arbor Bearings.....	Sealed and Permanently Lubricated

Cutting Capacities

Maximum Depth of Cut At 90 Degrees.....	3-1/8 in.
Maximum Depth of Cut At 45 Degrees.....	2-3/16 in.
Maximum Rip To Right of Blade-Standard Rails.....	29-1/2 in.
Maximum Rip To Left of Blade.....	13-1/2 in.

Table Information

Floor To Table Height.....	34 in.
Table Size Width.....	20 in.
Table Size Depth.....	27 in.
Table Size Thickness.....	1-7/8 in.
Table Size With Extension Wings Width.....	53-3/8 in.
Table Size With Extension Wings Depth.....	27 in.
Table Size With Extension Wings Thickness.....	1-7/8 in.
Distance Front of Table To Center Of Blade.....	17-1/8 in.
Distance Front of Table To Blade At Maximum Cut.....	12-1/2 in.

Fence Information

Fence Type.....	Camlock T-Shaped Fence with HDPE Face
Fence Size Length.....	39-5/16 in.
Fence Size Width.....	3-7/8 in.
Fence Size Height.....	2-1/2 in.
Fence Rail Type.....	Square Steel Tubing
Fence Rail Length.....	62 in.
Fence Rail Width.....	2-3/4 in.
Fence Rail Height.....	2 in.



Miter Gauge Information

Miter Gauge Slot Type..... T-Slot
 Miter Gauge Slot Size Width..... 3/4 in.
 Miter Gauge Slot Size Height..... 3/8 in.

Construction

Type..... Cabinet
 Table..... Precision Ground Cast Iron
 Wings..... Precision Ground Cast Iron
 Trunnions..... Cast Iron
 Base..... Pre-Formed Steel
 Body Assembly..... Pre-Formed Steel
 Fence Assembly..... Steel with HDPE Side Plates
 Rails..... Steel
 Miter Gauge Construction..... Cast Iron with Steel Bar
 Guard..... Steel and Plastic

Other Related Information

Paint..... Powder Coated
 Number of Dust Ports..... 1
 Dust Port Size..... 4 in.

Other

ISO 9001 Factory Yes
 Country Of Origin China
 Warranty 2 Year
 Serial Number Location ID Label on Cabinet
 Customer Assembly & Setup Time 1 Hour

Features

- T-slot miter gauge with extruded aluminum fence and flip stop
- Leeson Motor
- Precision Ground Cast Iron Table
- Cast Iron Trunnions
- 4" Dust Port
- Riving Knife and Blade Guard
- Camlock T-Shaped Fence with HDPE Face
- Quick-Release Device for Changing Guard/Riving Knife
- Powder Coated Paint
- Standard and Dado Table Inserts
- Quick Release Riving Knife
- Quick Release Motor Guard
- Quick Release Splitter Assembly
- Easy Glide Fence System
- Knurled Knobs for Adjusting Fence
- Nylon Runners Inside Fence Head Assembly
- Recessed Screw Holding Table Insert

MACHINE SPECIFICATIONS



© Woodstock International, Inc. • Phone: (800) 840-8420 • Web: www.shopfox.biz

MODEL W1820 SHOP FOX® CABINET SAW W/ RIVING KNIFE & LONG RAILS

Product Dimensions

Weight..... 546 lbs.
 Width (side-to-side) x Depth (front-to-back) x Height..... 82 x 45-1/2 x 40 in.
 Footprint (Length x Width)..... 22-1/4 x 20 in.

Shipping Dimensions

Carton #1

Type..... Cardboard/Wood Skids
 Content..... Machine & Table Extension
 Weight..... 481 lbs.
 Length x Width x Height..... 33 x 30 x 40 in.

Carton #2

Type..... Cardboard
 Content..... Fence
 Weight..... 27 lbs.
 Length x Width x Height..... 42 x 17 x 7 in.

Carton #3

Type..... Cardboard
 Content..... Rails
 Weight..... 71 lbs.
 Length x Width x Height..... 92 x 7 x 5 in.

Electrical

Power Requirement..... 220V, Single-Phase, 60 Hz
 Minimum Circuit Size..... 20A
 Switch..... Magnetic with Thermal Overload Protection
 Switch Voltage..... 220V
 Cord Length..... 6 ft.
 Cord Gauge..... 14 gauge
 Plug Included..... Yes
 Included Plug Type..... 6-20



Motors

Main

Type.....	TEFC Capacitor Start Induction
Horsepower.....	3 HP
Voltage.....	230V
Phase.....	Single
Amps.....	12.8A
Speed.....	3450 RPM
Cycle.....	60 Hz
Number of Speeds.....	1
Power Transfer	Triple V-Belt Drive
Bearings.....	Shielded and Permanently Sealed

Main Specifications

Blade Information

Maximum Blade Diameter.....	10 in.
Riving Knife/Spreader Thickness.....	0.1 in. (2.5mm)
Required Blade Body Thickness.....	0.071-0.094 in. (1.8-2.4mm)
Required Blade Kerf Thickness.....	0.102-0.126 in. (2.6-3.2mm)
Maximum Width of Dado.....	13/16 in.
Blade Tilt.....	Left 0-45 deg.
Arbor Size.....	5/8 in.
Arbor Speed.....	4300 RPM
Arbor Bearings.....	Sealed and Permanently Lubricated

Cutting Capacities

Maximum Depth of Cut At 90 Degrees.....	3-1/8 in.
Maximum Depth of Cut At 45 Degrees.....	2-3/16 in.
Maximum Rip To Right of Blade-Standard Rails.....	49 in.
Maximum Rip To Left of Blade.....	13-1/2 in.

Table Information

Floor To Table Height.....	34 in.
Table Size Width.....	20 in.
Table Size Depth.....	27 in.
Table Size Thickness.....	1-7/8 in.
Table Size With Extension Wings Width.....	72 in.
Distance Front of Table To Center Of Blade.....	17-1/8 in.
Distance Front of Table To Blade At Maximum Cut.....	12-1/2 in.

Fence Information

Fence Type.....	Camlock T-Shaped Fence with HDPE Face
Fence Size Length.....	39-5/16 in.
Fence Size Width.....	3-7/8 in.
Fence Size Height.....	2-1/2 in.
Fence Rail Type.....	Square Steel Tubing
Fence Rail Length.....	82 in.
Fence Rail Width.....	2-3/4 in.
Fence Rail Height.....	2 in.

Miter Gauge Information

Miter Gauge Slot Type.....	T-Slot
Miter Gauge Slot Size Width.....	3/4 in.
Miter Gauge Slot Size Height.....	3/8 in.

Construction

Type.....	Cabinet
Table.....	Precision Ground Cast Iron
Wings.....	Precision Ground Cast Iron
Trunnions.....	Cast Iron
Base.....	Pre-Formed Steel
Body Assembly.....	Pre-Formed Steel
Fence Assembly.....	Steel with HDPE Side Plates
Rails.....	Steel
Miter Guage Construction.....	Cast Iron with Steel Bar
Guard.....	Steel and Plastic

Other Related Information

Paint.....	Powder Coated
Number of Dust Ports.....	1
Dust Port Size.....	4 in.
Mobile Base.....	D2057A

Other

ISO 9001 Factory	Yes
Country Of Origin	China
Warranty	2 Year
Serial Number Location	ID Label on Cabinet
Customer Assembly & Setup Time	1 Hour

Features

- Leeson Motor
- Precision Ground Cast Iron Table
- Cast Iron Trunnions
- 4" Dust Port
- T-Slot Miter Gauge
- Riving Knife and Blade Guard
- Camlock T-Shaped Fence with HDPE Face
- Quick-Release Device for Changing Guard/Riving Knife
- Powder Coated Paint
- Standard and Dado Table Inserts
- Quick Release Riving Knife
- Quick Release Motor Guard
- Quick Release Splitter Assembly
- Easy Glide Fence System
- Knurled Knobs for Adjusting Fence
- Nylon Runners Inside Fence Head Assembly
- T-Square Type Fence System
- Recessed Screw Holding Table Insert
- Device on Blade Guard Allows Enabling or Disabling of Anti-Kickback Pawls

SAFETY

For Your Own Safety, Read Manual Before Operating Machine

SAFETY

The purpose of safety symbols is to attract your attention to possible hazardous conditions. This manual uses a series of symbols and signal words intended to convey the level of importance of the safety messages. The progression of symbols is described below. Remember that safety messages by themselves do not eliminate danger and are not a substitute for proper accident prevention measures—this responsibility is ultimately up to the operator!



Indicates an imminently hazardous situation which, if not avoided, **WILL** result in death or serious injury.



Indicates a potentially hazardous situation which, if not avoided, **COULD** result in death or serious injury.



Indicates a potentially hazardous situation which, if not avoided, **MAY** result in minor or moderate injury.

NOTICE

This symbol is used to alert the user to useful information about proper operation of the equipment or a situation that may cause damage to the machinery.

Standard Machinery Safety Instructions

OWNER'S MANUAL. Read and understand this owner's manual **BEFORE** using machine.

TRAINED OPERATORS ONLY. Untrained operators have a higher risk of being hurt or killed. Only allow trained/supervised people to use this machine. When machine is not being used, disconnect power, remove switch keys, or lock-out machine to prevent unauthorized use—especially around children. Make workshop kid proof!

DANGEROUS ENVIRONMENTS. Do not use machinery in areas that are wet, cluttered, or have poor lighting. Operating machinery in these areas greatly increases the risk of accidents and injury.

MENTAL ALERTNESS REQUIRED. Full mental alertness is required for safe operation of machinery. Never operate under the influence of drugs or alcohol, when tired, or when distracted.

ELECTRICAL EQUIPMENT INJURY RISKS. You can be shocked, burned, or killed by touching live electrical components or improperly grounded machinery. To reduce this risk, only allow an electrician or qualified service personnel to do electrical installation or repair work, and always disconnect power before accessing or exposing electrical equipment.

DISCONNECT POWER FIRST. Always disconnect machine from power supply **BEFORE** making adjustments, changing tooling, or servicing machine. This eliminates the risk of injury from unintended startup or contact with live electrical components.

EYE PROTECTION. Always wear ANSI-approved safety glasses or a face shield when operating or observing machinery to reduce the risk of eye injury or blindness from flying particles. Everyday eyeglasses are not approved safety glasses.

WEARING PROPER APPAREL. Do not wear clothing, apparel, or jewelry that can become entangled in moving parts. Always tie back or cover long hair. Wear non-slip footwear to avoid accidental slips, which could cause loss of workpiece control.

HAZARDOUS DUST. Dust created while using machinery may cause cancer, birth defects, or long-term respiratory damage. Be aware of dust hazards associated with each workpiece material, and always wear a NIOSH-approved respirator to reduce your risk.

HEARING PROTECTION. Always wear hearing protection when operating or observing loud machinery. Extended exposure to this noise without hearing protection can cause permanent hearing loss.

REMOVE ADJUSTING TOOLS. Tools left on machinery can become dangerous projectiles upon startup. Never leave chuck keys, wrenches, or any other tools on machine. Always verify removal before starting!

INTENDED USAGE. Only use machine for its intended purpose and never make modifications not approved by Woodstock. Modifying machine or using it differently than intended may result in malfunction or mechanical failure that can lead to serious personal injury or death!

AWKWARD POSITIONS. Keep proper footing and balance at all times when operating machine. Do not overreach! Avoid awkward hand positions that make workpiece control difficult or increase the risk of accidental injury.

CHILDREN & BYSTANDERS. Keep children and bystanders at a safe distance from the work area. Stop using machine if they become a distraction.

GUARDS & COVERS. Guards and covers reduce

FORCING MACHINERY. Do not force machine. It will do the job safer and better at the rate for which it was designed.

NEVER STAND ON MACHINE. Serious injury may occur if machine is tipped or if the cutting tool is unintentionally contacted.

STABLE MACHINE. Unexpected movement during operation greatly increases risk of injury or loss of control. Before starting, verify machine is stable and mobile base (if used) is locked.

USE RECOMMENDED ACCESSORIES. Consult this owner's manual or the manufacturer for recommended accessories. Using improper accessories will increase risk of serious injury.

UNATTENDED OPERATION. To reduce the risk of accidental injury, turn machine **OFF** and ensure all moving parts completely stop before walking away. Never leave machine running while unattended.

MAINTAIN WITH CARE. Follow all maintenance instructions and lubrication schedules to keep machine in good working condition. A machine that is improperly maintained could malfunction, leading to serious personal injury or death.

CHECK DAMAGED PARTS. Regularly inspect machine for any condition that may affect safe operation. Immediately repair or replace damaged or mis-adjusted parts before operating machine.

MAINTAIN POWER CORDS. When disconnecting cord-connected machines from power, grab and pull the plug—NOT the cord. Pulling the cord may damage the wires inside, resulting in a short. Do not handle cord/plug with wet hands. Avoid cord damage by keeping it away from heated surfaces, high traffic areas, harsh chemicals, and wet/damp locations.

Additional Safety for Table Saws

HAND POSITIONING. Never purposely touch a saw blade during operation. Always keep hands/fingers out of the blade path; place them where they cannot slip into the blade accidentally. Never reach around, behind, or over the blade. Touching a spinning saw blade will cause serious laceration or amputation injuries.

BLADE GUARD. Use the blade guard for all “through cuts” for which it can be used. (A through cut is an operation where the blade cuts completely through the top of the workpiece.) Make sure the blade guard is installed and adjusted correctly; promptly repair or replace it if damaged. Always re-install blade guard immediately after operations that require its removal. Operating saw with the blade guard removed greatly increases the risk of severe laceration or amputation injuries from accidental blade contact.

RIVING KNIFE. Use the riving knife for all “non-through cuts” for which it can be used. (A non-through cut is an operation where the blade does not cut through the top of the workpiece.) Make sure the riving knife is aligned and positioned correctly; and promptly repair or replace it if damaged. Using the riving knife incorrectly will increase the risk of kickback or accidental blade contact.

KICKBACK. Kickback occurs when the saw blade ejects the workpiece back toward the operator. Know how to reduce the risk of kickback, and learn how to protect yourself if it does occur.

FEEDING WORKPIECE. Feeding the workpiece incorrectly will increase risk of kickback. Never start the saw with a workpiece touching the blade; allow the blade to reach full speed before cutting. Only feed the workpiece against the direction of blade rotation. Always use some type of guide (fence, miter gauge, sliding table or sled, etc.) to feed the workpiece in a straight line. Never back a workpiece out of a cut or try to move it backwards or sideways after starting a cut. Feed cuts all the way through to completion. Never perform any operation “freehand” (making a cut without using a fence or guide).

FENCE. Make sure the fence remains properly adjusted and parallel with the blade. Always lock the fence in place before using. Using or adjusting the fence incorrectly will increase risk of kickback.

PUSH STICKS/BLOCKS. Use push sticks or push blocks whenever possible to keep your hands farther away from the blade while cutting; in the event of an accident these devices will often take damage that would have happened to hands/fingers.

CUT-OFF PIECES. Never use your hands to move cut-offs away from the blade while the saw is running. If a cut-off becomes trapped between the blade and table insert, turn the saw **OFF** and allow the blade to completely stop before removing it.

BLADE ADJUSTMENTS. Adjusting the blade height or tilt during operation increases the risk of crashing the blade and sending metal fragments flying with deadly force at the operator or bystanders. Only adjust the blade height and tilt when the blade is completely stopped and the saw is **OFF**.

CHANGING BLADES. Always disconnect power before changing blades. Changing blades while the saw is connected to power greatly increases the injury risk if saw is accidentally powered up.

DAMAGED SAW BLADES. Never use blades that have been dropped or otherwise damaged. Damaged blades can fly apart and strike the operator with shards of metal.

DADO AND RABBET OPERATIONS. DO NOT attempt dado or rabbeting operations without first reading those sections in this manual. Dado and rabbeting operations require special attention because they must be performed with the blade guard removed.

Preventing Kickback

Below are ways to avoid the most common causes of kickback:

- Only cut workpieces with at least one smooth and straight edge. DO NOT cut warped, cupped or twisted wood.
- Never attempt freehand cuts. If the workpiece is not fed parallel with the blade, kickback will likely occur. Always use the rip fence or miter gauge to support the workpiece.
- Make sure the spreader or riving knife is aligned with the blade. A misaligned spreader or riving knife can cause the workpiece to catch or bind, increasing the chance of kickback. If you think that your spreader or riving knife is not aligned with the blade, check it immediately!
- Take the time to check and adjust the rip fence parallel with the blade; otherwise, the chances of kickback are extreme.
- The spreader or riving knife maintains the kerf in the workpiece, reducing the chance of kickback. Always use the riving knife for all non-through operations, unless a dado blade is installed. Always use the spreader with the blade guard for all through cuts.
- Feed cuts through to completion. Anytime you stop feeding a workpiece in the middle of a cut, the chance of kickback is greatly increased.
- Keep the blade guard installed and in good working order. Only remove it when performing non-through cuts and immediately re-install the blade guard when finished. Remember, always use the riving knife for all non-through operations, unless a dado blade is installed.
- Make multiple, shallow passes when performing a non-through cut. Making a deep non-through cut will greatly increase the chance of kickback.

Protecting Yourself From Kickback

Even if you know how to prevent kickback, it may still happen. Here are some ways to protect yourself if kickback DOES occur:

- Stand to the side of the blade during every cut. If kickback does occur, the thrown workpiece usually travels directly in front of the blade.
- Wear safety glasses or a face shield. In the event of kickback, your eyes and face are the most vulnerable part of your body.
- Never, for any reason, place your hand behind the blade. Should kickback occur, your hand may be pulled into the blade, which could cause amputation.
- Use a push stick to keep your hands farther away from the moving blade. If kickback occurs, the push stick will most likely take the damage that your hand would have received.
- Use featherboards or anti-kickback devices to prevent or slow down kickback.

WARNING

Statistics show that most common accidents among table saw users can be linked to kickback. Kickback is typically defined as the high-speed ejection of stock from the table saw toward its operator. In addition to the danger of the operator or others in the area being struck by the flying stock, it is often the case that the operator's hands are pulled into the blade during the kickback.

Glossary of Terms

The following is a list of common definitions, terms and phrases used throughout this manual as they relate to this table saw and woodworking in general. Become familiar with these terms for assembling, adjusting or operating this machine.

SAFETY

Arbor: A metal shaft extending from the drive mechanism that is the mounting location for the saw blade.

Bevel Cut: A cut made with the blade tilted to an angle between 0° and 45° to cut a beveled edge onto a workpiece. Refer to **Page 43** for more details.

Blade Guard Assembly: Metal or plastic safety device that mounts over the saw blade. Its function is to prevent the operator from coming into contact with the saw blade. Refer to **Page 36** for more details.

Crosscut: Cutting operation in which the crosscut fence is used to cut across the shortest width of the workpiece. Refer to **Page 41** for more details.

Dado Blade: Blade or set of blades that are used to cut grooves and rabbets. Refer to **Page 34** for more details. **DO NOT use a dado blade larger than 8" in diameter on this saw!** The saw and arbor are not intended to safely use a larger dado blade.

Dado Cut: Cutting operation that uses a dado blade to cut a flat bottomed groove into the face of the workpiece. Refer to **Page 44** for more details.

Featherboard: Safety device used to keep the workpiece against the rip fence and against the table surface. Refer to **Page 55** for more details.

Kerf: The resulting cut or gap in the workpiece after the saw blade passes through during a cutting operation.

Kickback: An event in which the workpiece is propelled back towards the operator at a high rate of speed.

Non-Through Cut: A cut in which the blade does not cut through the top of the workpiece. Refer to **Page 32** for more details.

Parallel: Being an equal distance apart at every point along two given lines or planes (i.e. the rip fence face is parallel to the face of the saw blade).

Perpendicular: Lines or planes that intersect and form right angles (i.e. the blade is perpendicular to the table surface).

Push Stick: Safety device used to push the workpiece through a cutting operation. Used most often when rip cutting thin workpieces. Refer to **Page 58** for more details.

Rabbet: Cutting operation that creates an L-shaped channel along the edge of the workpiece. Refer to **Page 47** for more details.

Rip Cut: Cutting operation in which the rip fence is used to cut across the widest width of the workpiece. Refer to **Page 40** for more details.

Riving Knife: Metal plate located behind the blade. It maintains the kerf opening in the wood when performing a cutting operation. Refer to **Page 38** for more details.

Straightedge: A tool used to check the flatness, parallelism, or consistency of a surface(s).

Thin Kerf Blade: A blade with a kerf or thickness that is thinner than a standard blade cannot be used on this saw.

Through Cut: A cut in which the blade cuts completely through the workpiece. Refer to **Page 32** for more details.

ELECTRICAL

Circuit Requirements

This machine must be connected to the correct size and type of power supply circuit, or fire or electrical damage may occur. Read through this section to determine if an adequate power supply circuit is available. If a correct circuit is not available, a qualified electrician **MUST** install one before you can connect the machine to power.

A power supply circuit includes all electrical equipment between the breaker box or fuse panel in the building and the machine. The power supply circuit used for this machine must be sized to safely handle the full-load current drawn from the machine for an extended period of time. (If this machine is connected to a circuit protected by fuses, use a time delay fuse marked D.)

Full-Load Current Rating

The full-load current rating is the amperage a machine draws at 100% of the rated output power. On machines with multiple motors, this is the amperage drawn by the largest motor or sum of all motors and electrical devices that might operate at one time during normal operations.

Full-Load Current Rating..... 12.8 Amps

Circuit Requirements

This machine is prewired to operate on a 220V power supply circuit that has a verified ground and meets the following requirements:

Circuit Type220V/240V, 60 Hz, Single-Phase
Circuit Size 20 Amps
Plug/Receptacle NEMA 6-20

⚠ WARNING

The machine must be properly set up before it is safe to operate. **DO NOT** connect this machine to the power source until instructed to do later in this manual.

⚠ WARNING



Incorrectly wiring or grounding this machine can cause electrocution, fire, or machine damage. To reduce this risk, only an electrician or qualified service personnel should do any required electrical work on this machine.

NOTICE

The circuit requirements listed in this manual apply to a dedicated circuit—where only one machine will be running at a time. If this machine will be connected to a shared circuit where multiple machines will be running at the same time, consult with an electrician to ensure that the circuit is properly sized for safe operation.

ELECTRICAL

Grounding Requirements

This machine **MUST** be grounded. In the event of certain types of malfunctions or breakdowns, grounding provides a path of least resistance for electric current to travel—in order to reduce the risk of electric shock.

Improper connection of the equipment-grounding wire will increase the risk of electric shock. The wire with green insulation (with/without yellow stripes) is the equipment-grounding wire. If repair or replacement of the power cord or plug is necessary, do not connect the equipment-grounding wire to a live (current carrying) terminal.

Check with a qualified electrician or service personnel if you do not understand these grounding requirements, or if you are in doubt about whether the tool is properly grounded. If you ever notice that a cord or plug is damaged or worn, disconnect it from power, and immediately replace it with a new one.

For 220V Connection

This machine is equipped with a power cord that has an equipment-grounding wire and NEMA 6-20 grounding plug. The plug must only be inserted into a matching receptacle (see **Figure**) that is properly installed and grounded in accordance with local codes and ordinances.

Extension Cords

We do not recommend using an extension cord with this machine. Extension cords cause voltage drop, which may damage electrical components and shorten motor life. Voltage drop increases with longer extension cords and the gauge smaller gauge sizes (higher gauge numbers indicate smaller sizes).

Any extension cord used with this machine must contain a ground wire, match the required plug and receptacle, and meet the following requirements:

- Minimum Gauge Size at 220V** 14 AWG
- Maximum Length (Shorter is Better)** 50 ft.

⚠️ WARNING

The machine must be properly set up before it is safe to operate. **DO NOT** connect this machine to the power source until instructed to do later in this manual.

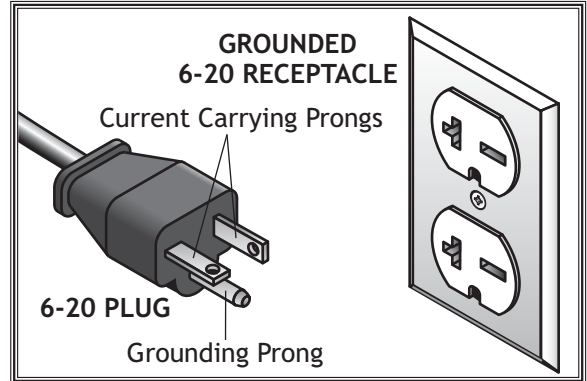
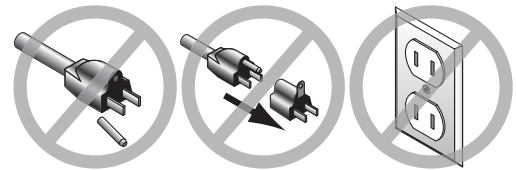

Figure 2. NEMA 6-20 plug & receptacle.

⚠️ CAUTION



DO NOT modify the provided plug or use an adapter if the plug will not fit the receptacle. Instead, have an electrician install the proper receptacle on a power supply circuit that meets the requirements for this machine.

ELECTRICAL

SETUP

Unpacking

This machine has been carefully packaged for safe transportation. If you notice the machine has been damaged during shipping, please contact your authorized Shop Fox dealer immediately.

Items Needed for Setup

The following items are needed, but not included, to setup your machine.

Description	Qty
• Safety Glasses for Each Person	1
• Degreaser or Solvent for Cleaning	Varies
• Disposable Rags for Cleaning	Varies
• Straightedge	1
• Level	1
• Dust Collection System	1
• 4" Dust Hose	1
• 4" Hose Clamp	1
• Assistant for Lifting	1
• Needle Nose Pliers	1
• Wrench or Socket 17mm	1
• Wrenches or Sockets 13mm	2
• Wrench or Socket 10mm	1
• Wrench 14mm	1
• Adjustable Wrench	1



⚠ WARNING

This machine presents serious injury hazards to untrained users. Read through this entire manual to become familiar with the controls and operations before starting the machine!

⚠ WARNING



Wear safety glasses during the entire setup process!



⚠ WARNING

USE helpers or power lifting equipment to lift this machine. Otherwise, serious personal injury may occur.

SETUP

Inventory

The following is a description of the main components shipped each W1819/W1820 model. Lay the components out to inventory them.

Note: If you can't find an item on this list, check the mounting location on the machine or examine the packaging materials carefully. Occasionally we pre-install certain components for shipping purposes.

Box Contents: (Figures 3-5)	Qty
A. Main Table Saw Unit.....	1
B. Extension Wings.....	2
C. Dust Port.....	1
D. Motor Door.....	1
E. Blade Guard Assembly	1
F. Riving Knife.....	1
G. Miter Fence and Flip Stop.....	1
H. Wrench 27mm.....	1
I. Wrench 22/24mm.....	1
J. Dado Table Insert.....	1
K. Hex Wrench Set (Eight Pieces) 1.5-8mm.....	1
L. Key 5 x 5 x 40.....	1
M. Handwheel Lock Knob	1
N. Handwheel Handle	1
O. Handwheel.....	1
P. Push Stick.....	1
Q. Saw Blade 10" x 40T.....	1

Hardware (Not Shown)	Qty
• Phillips Head Screw M6-1 x 12 (Magnetic Switch)	1
• Hex Bolts M8-1.25 x 16 (Magnetic Switch)	2
• Lock Washers 6mm (Magnetic Switch)	3
• Flat Washers 6mm (Magnetic Switch)	3



Figure 3. Main table saw unit.

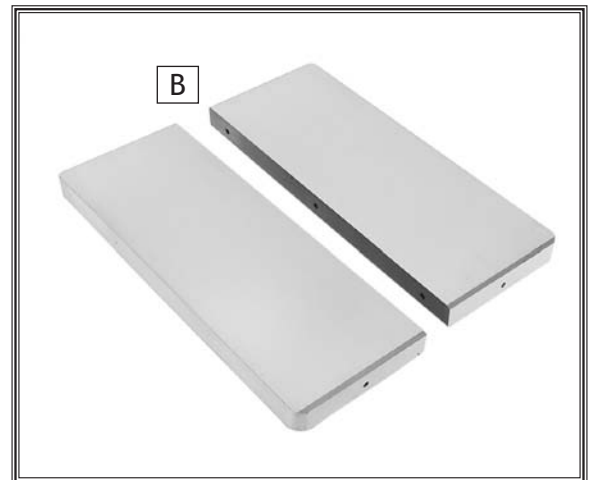

Figure 4. Extension wings.

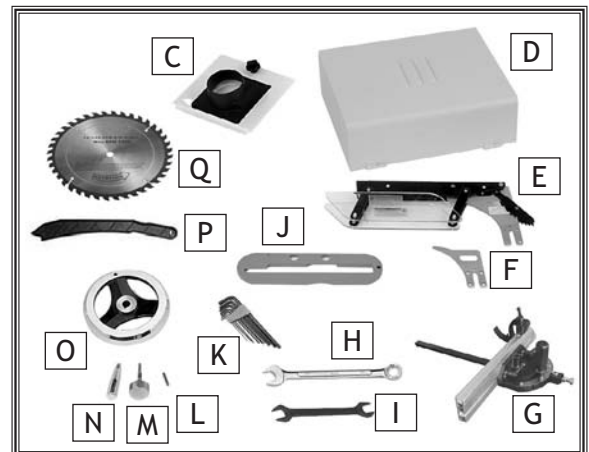

Figure 5. Component inventory.

SETUP

Fence Inventory W1819

Components	Qty
A. Front Rail Rectangular Tube 62".....	1
B. Front Rail Tape Scale	1
C. Front Rail 50".....	1
D. Rear Rail 50".....	1
E. Fence Assembly	1
F. Fence Handle.....	1
G. Rear Rail Foot M12-1.75	1
H. Hex Wrench 6mm.....	1
I. Extension Table 27" x 13 ³ / ₄ "	1

Hardware and Tools (Not Shown)	Qty
• Cap Screws M6-1 x 16 (Front Rail/Tube).....	3
• Flat Washers 6mm (Front Rail/Tube).....	3
• Lock Washers (Front Rail/Tube).....	3
• Hex Bolts M8-1.25 x 40 (Front & Rear Rails)	6
• Flat Washers 8mm (Front & Rear Rails).....	14
• Lock Washers 8mm (Front & Rear Rails).....	8
• Hex Nuts M8-1.25 (Front & Rear Rails)	6
• Hex Bolts M8-1.25 x 30 (Rear Rail)	2
• Hex Bolts M6-1 x 16 (Extension Table)	4
• Hex Nuts M6-1 (Extension Table).....	4
• Flat Washers 6mm (Extension Table)	8
• Lock Washers 6mm (Extension Table)	4

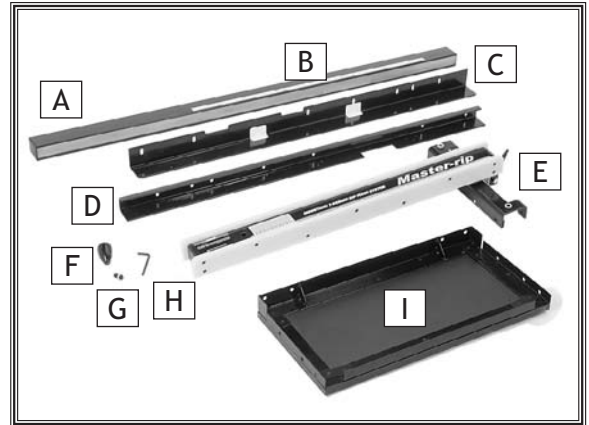

Figure 6. Inventory needed to install the fence on the Model W1819.

SETUP

Fence Inventory W1820

Components	Qty
A. Front Rail Rectangular Tube 82".....	1
B. Front Rail 70".....	1
C. Rear Rail 70".....	1
D. Fence Assembly.....	1
D. Fence Handle.....	1
F. Rear Rail Foot.....	1
G. Hex Wrench 6mm.....	1
H. Front Rail Tape Scale.....	1
I. Extension Table.....	1
J. Legs.....	2

Hardware and Tools (Not Shown)	Qty
• Feet w/Bolts & Hex Nuts.....	2 Sets
• Cap Screws M6-1 x 16 (Front Rail/Tube).....	5
• Flat Washers 6mm (Front Rail/Tube).....	5
• Lock Washers (Front Rail/Tube).....	5
• Hex Bolts M8-1.25 x 40 (Front & Rear Rails).....	6
• Flat Washers 8mm (Front & Rear Rails).....	14
• Lock Washers 8mm (Front & Rear Rails).....	8
• Hex Nuts M8-1.25 (Front & Rear Rails).....	6
• Hex Bolts M8-1.25 x 30 (Rear Rail).....	2
• Hex Bolts M6-1 x 16 (Extension Table).....	6
• Hex Nuts M6-1 (Extension Table).....	6
• Flat Washers 6mm (Extension Table).....	12
• Lock Washers 6mm (Extension Table).....	6
• Cap Screws M8-1.25 x 20 (Legs).....	4
• Flat Washers 8mm (Legs).....	4
• Lock Washers 8mm (Legs).....	4
• Hex Nuts M8-1.25 (Legs).....	4

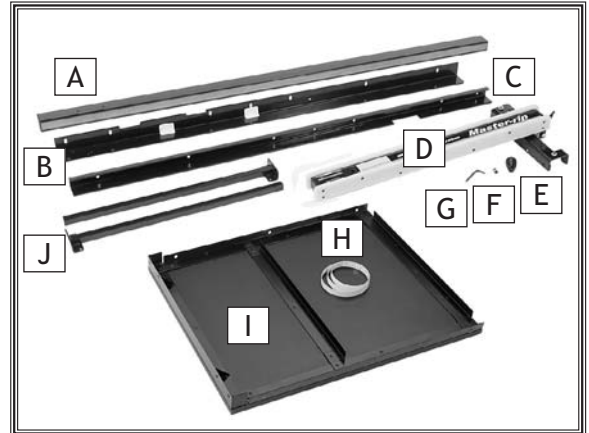

Figure 7. Inventory needed to install the fence on the Model W1820.

Machine Placement

- **Floor Load:** This machine distributes a heavy load in a small footprint. Some residential floors may require additional bracing to support both machine and operator.
- **Working Clearances:** Consider existing and anticipated needs, size of material to be processed through the machine, and space for auxiliary stands, work tables or other machinery when establishing a location for your table saw.
- **Lighting:** Lighting should be bright enough to eliminate shadow and prevent eye strain.
- **Electrical:** Electrical circuits must be dedicated or large enough to handle amperage requirements. Outlets must be located near each machine, so power or extension cords are clear of high-traffic areas. Follow local electrical codes for proper installation of new lighting, outlets, or circuits.

Cleaning Machine

The table and other unpainted parts of your table saw are coated with a waxy grease that protects them from corrosion during shipment. Clean this grease off with a solvent cleaner or citrus-based degreaser. DO NOT use chlorine-based solvents such as brake parts cleaner or acetone—if you happen to splash some onto a painted surface, you will ruin the finish.

	<p>! WARNING USE helpers or power lifting equipment to lift this machine. Otherwise, serious personal injury may occur.</p>
--	--

	<p>! CAUTION MAKE your shop “child safe.” Ensure that your workplace is inaccessible to children by closing and locking all entrances when you are away. NEVER allow untrained visitors in your shop when assembling, adjusting or operating equipment.</p>
--	--

	<p>! WARNING NEVER clean with gasoline or other petroleum-based solvents. Most have low flash points, which make them extremely flammable. A risk of explosion and burning exists if these products are used. Serious personal injury may occur if this warning is ignored!</p>
--	--

	<p>! CAUTION ALWAYS work in well-ventilated areas far from possible ignition sources when using solvents to clean machinery. Many solvents are toxic when inhaled or ingested. Use care when disposing of waste rags and towels to be sure they DO NOT create fire or environmental hazards.</p>
--	---

SETUP

Assembly

Assembly steps are the same for the Model W1819 and W1820 except where noted. Assembly consists of installing minor components, the extension wings, front and rear rails, extension table, and the legs (Model W1820 only).

To assemble the table saw, do these steps:

1. Pull the magnetic switch out of the saw cabinet and install the door by inserting the door pins into the hinge sockets on the cabinet (see **Figure 8**).
2. Place the included 5 x 5 x 40 key in the handwheel shaft and slide the handwheel onto the shaft on the front of the table saw. Use the included 2.5mm hex wrench to tighten the set screw (see **Figure 9**) on the side of the handwheel until it is secure.
3. Thread the handwheel lock knob into the center of the handwheel and tighten, then install the handle into the handwheel and tighten with a 14mm wrench (see **Figure 10**).
4. Remove the shipping brace (see **Figure 11**) using a 17mm wrench and a pair of needle nose pliers. Re-install the M10-1.5 x 25 hex bolt, flat washer, hex nut and the cotter pin, and save the shipping brace.



Figure 8. Door installed.



Figure 9. Handwheel set screw.

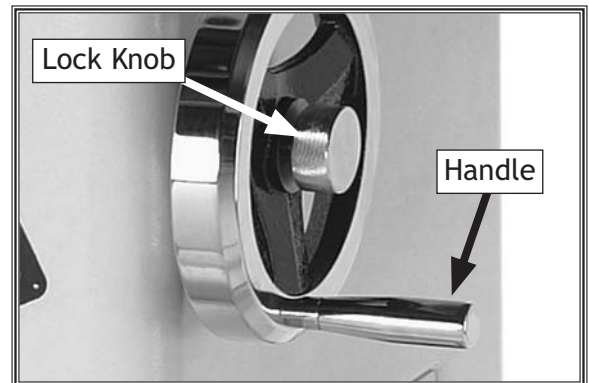

Figure 10. Handwheel installed.



Figure 11. Shipping brace location.

5. Insert the lip of the lower part of the dust port into the cabinet and tighten the thumb knob to secure (see Figure 12).
6. Remove the M8-1.25 x 30 cap screws, 8mm flat washers, and 8mm lock washers from the ends of the main table.
7. Inspect the extension wings and main table mating surfaces for burrs or foreign materials that may inhibit assembly.

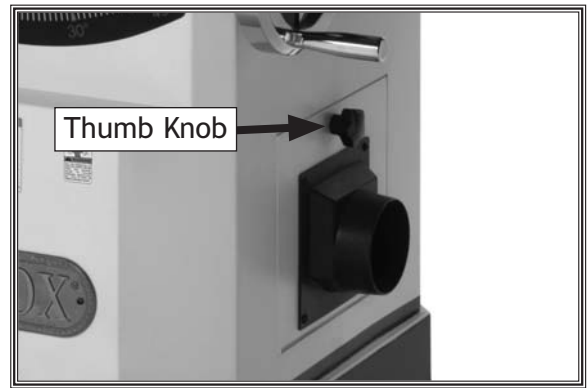

Figure 12. Dust port installed.

The mating edges of the wings and the table must be clean, smooth, and flat. Use a wire brush or file if necessary to clean up the edges. This step will ensure that the wings mount properly to the main table.

8. While a helper holds the wings in place, attach each extension wing to the main table with the four M8-1.25 x 30 cap screws, 8mm lock washers, and 8mm flat washers removed in Step 6 (see Figure 13).
9. Place the straightedge across the extension wings and main table to make sure that the combined table surface is flush and flat.

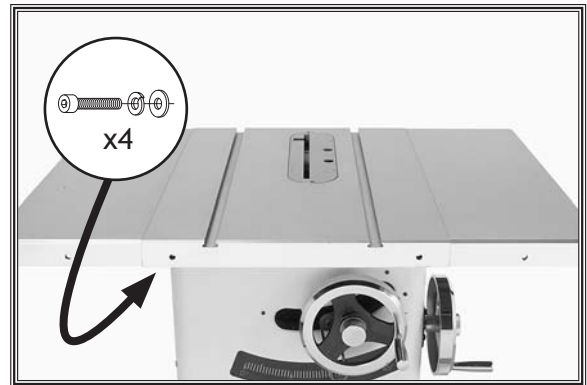

Figure 13. Extension wings installed.

- If the combined table surface is flat, skip to the next step.
- If the outside end of the extension wing tilts down, use a strip of masking tape along the bottom edge of the main table to shim the extension wing up (Figure 14).
- If the outside end of the extension wing tilts up, use a strip of masking tape along the top edge of the main table to shim the extension wing down (Figure 15).

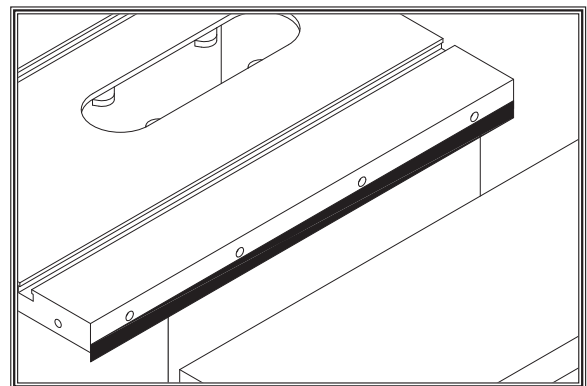

Figure 14. Masking tape location for tilting the extension wing up.

Note: After re-installing wings, remove all excess masking tape with a razor blade.

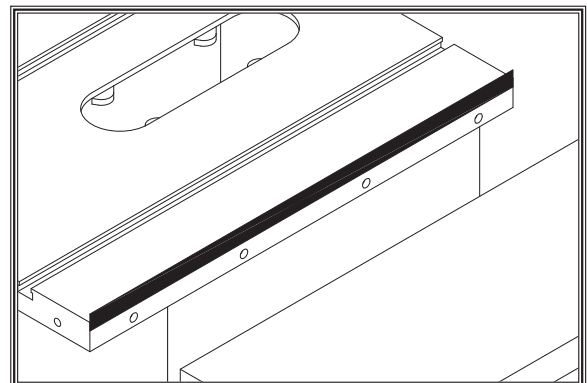

Figure 15. Masking tape location for adjusting the extension wing down.

10. Install the front rail onto the table and extension wings with four M8-1.25 x 40 hex bolts, eight 8mm flat washers, four 8mm lock washers, and four M8-1.25 hex nuts, as shown in **Figure 16**.

Before final tightening, make sure the front rail is set $\frac{3}{16}$ " below the beveled edge along the entire length of the table.

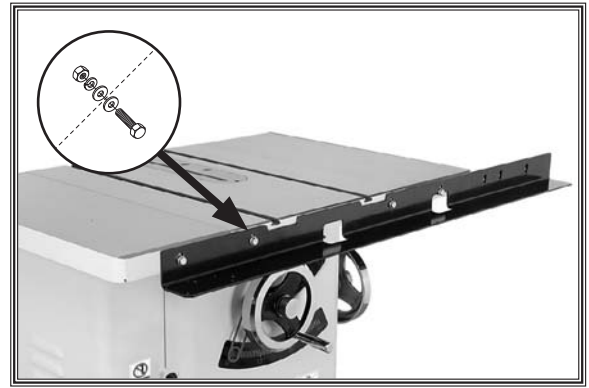

Figure 16. Front rail installed (W1819).

11. **W1819 ONLY:** Install the 62" front rail tube onto the 50" front rail with the three M6-1 x 16 cap screws, 6mm flat washers, and 6mm lock washers, as shown in **Figure 17**.

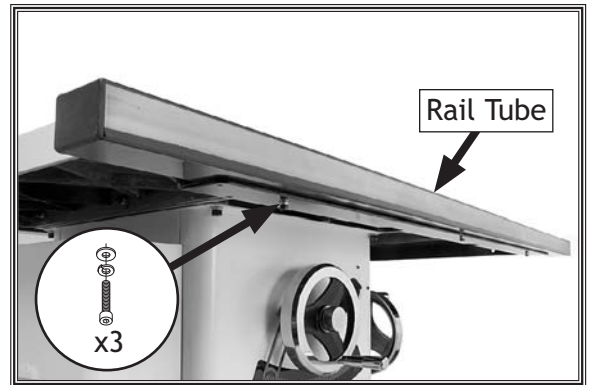

Figure 17. Model W1819 tube attached to front rail.

W1820 ONLY: Install the 82" front rail tube onto the 70" front rail with five M6-1 x 16 cap screws, 6mm lock washers, and 6mm flat washers, as shown in **Figure 18**.

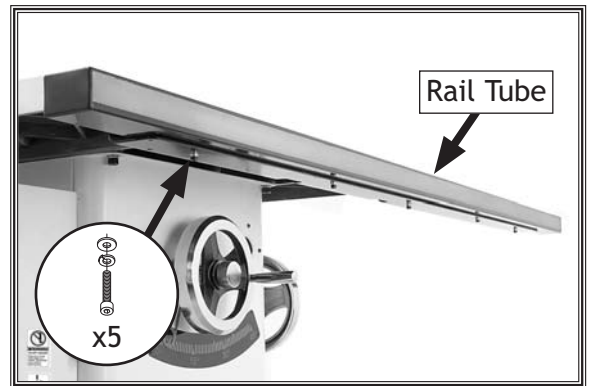

Figure 18. Model W1820 tube attached to front rail.

12. Attach the rear rail to the holes on the main table using two M8-1.25 x 30 hex bolts, 8mm lock washers and 8mm flat washers, as shown in **Figure 19**.
13. Secure the rear rail to the extension wings with two M8-1.25 x 40 hex bolts, four 8mm flat washers, two 8mm lock washers and two M8-1.25 hex nuts.

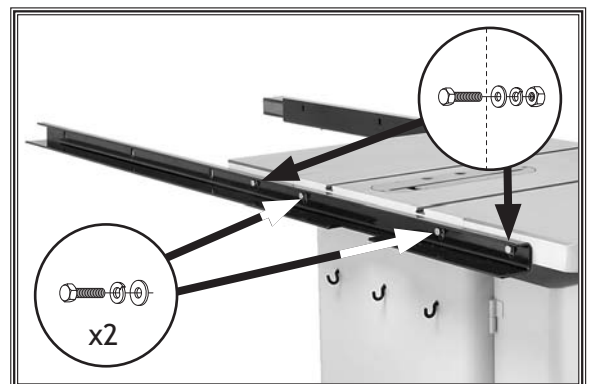

Figure 19. Rear rail installed (W1820).

SETUP

Note: Before tightening the fasteners, check to make sure the top edge of the rear rail is flush with the lowest edge of both T-slots (see **Figure 20**), so the miter gauge will slide smoothly when installed later.

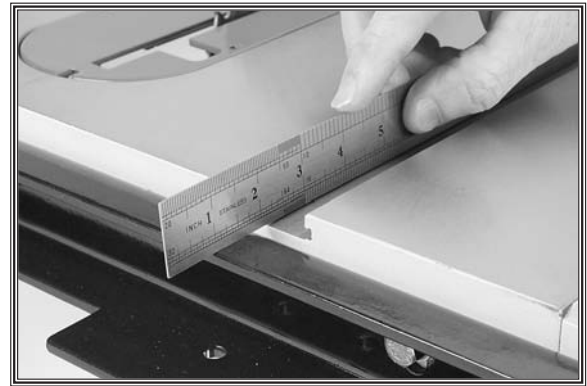

Figure 20. Verifying rear rail is flush with bottom of T-slot.

W1819 Extension Table

1. Install the extension table between the front and rear rails with the four M6-1 x 16 hex bolts, eight 6mm flat washers, four 6mm lock washers, and four M6-1 hex nuts, as shown in **Figure 21**.

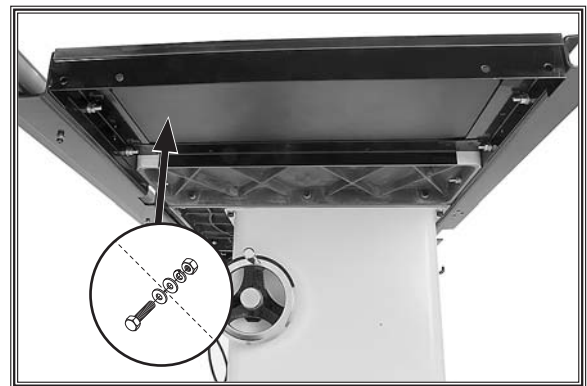

Figure 21. Model W1819 extension table installed.

2. Using a long straightedge, adjust the extension table so it is flat (both flush and parallel) with the main table and extension wings (**Figure 22**), then tighten the fasteners.

W1820 Extension Table

1. Remove the six M6-1 x 16 hex bolts, (12) 6mm flat washers, six 6mm lock washers, and six M6-1 hex nuts from the extension table.
2. While an assistant holds the extension table between the front and rear rails, fasten the extension table to the rails with the fasteners removed in **Step 1**.
3. Thread the feet into the legs with the two M8-1.25 x 60 hex bolts, place the legs under the table, and thread the feet out until the top of each leg is against the underside corner of the table.
4. Use the four M8-1.25 x 20 cap screws, 8mm lock washers, 8mm flat washers, and M8-1.25 hex nuts to secure the legs to the end of the extension table, as shown in **Figure 23**.



Figure 22. Adjusting Model W1819 extension table flush with wing and table.

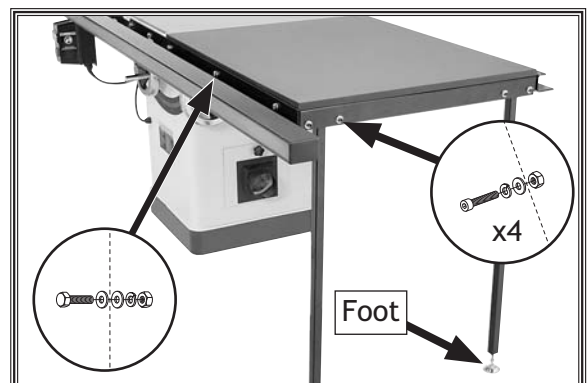

Figure 23. Model W1820 extension table installed.

SETUP

5. Adjust the extension table so it is flat (both flush and parallel) with the main table, using a long straightedge (similar to the method shown in **Figure 22**). This can be done by loosening the mounting bolts and adjusting the feet up/down as needed.
6. Tighten the extension table mounting bolts, and tighten the hex nuts on the feet up against the legs so they will not move.

Fence & Miter Gauge

1. Attach the fence handle to the fence and thread the rear rail foot into the bottom of the fence (see **Figure 24**).
2. Place the fence on the rails on the right hand side of the blade (see **Figure 25**).

Note: Make sure the cam foot contacts the cam on the fence lock handle before you place the fence on the rail, otherwise the fence will not lock onto the rail tube.

3. Slide the miter gauge into the T-slot on the left hand side of the blade.

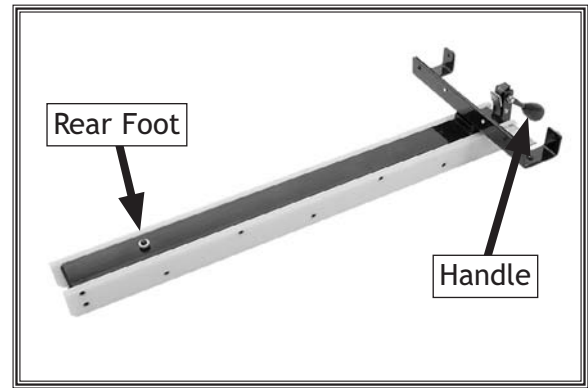

Figure 24. Fence assembled.

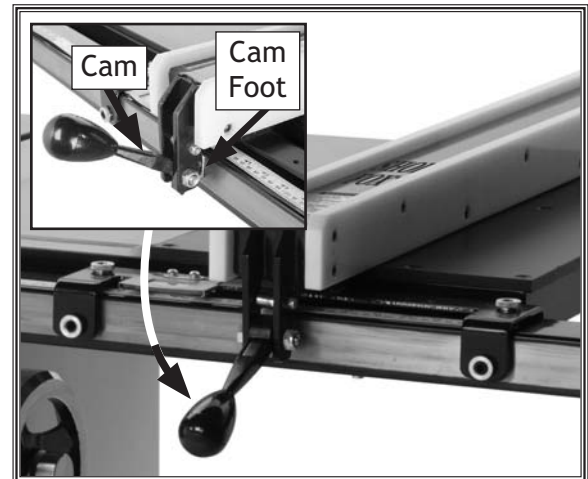

Figure 25. Fence installed on rails.

Magnetic Switch

1. Install the magnetic switch onto the bottom left hand side of the front rail using two M6-1 x 12 hex bolts, 6mm lock washers, and 6mm flat washers, as shown in **Figure 26**.
2. Secure the top of the switch to the rail with an M6-1 x 12 Phillip head screw, 6mm lock washer, and flat washer.

Saw Blade

1. Remove the table insert by unscrewing the screw that fastens it to the table.
2. Raise the arbor all the way up and set the blade angle at 0°.
3. Remove the arbor nut and arbor flange from the arbor, slide on the included 10" saw blade, making sure the teeth face the front of the saw, then install the arbor flange and arbor nut onto the blade. See **Page 35** for additional details.

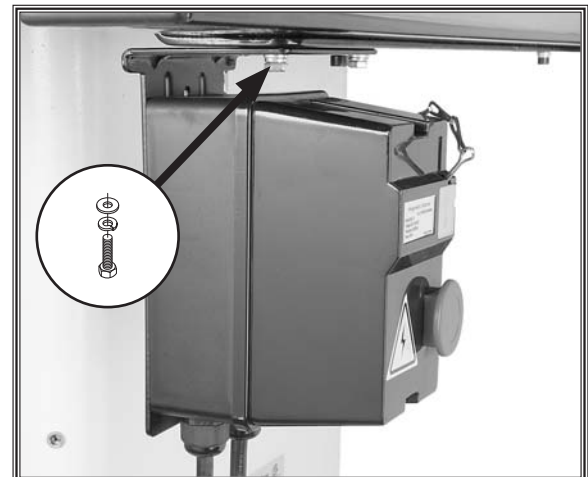

Figure 26. Magnetic switch installed.

SETUP

- Put on a pair of heavy leather gloves and use the included arbor wrenches to tighten the arbor nut (turn clockwise to tighten), as shown in **Figure 27**.

Checking Fence Parallelism

- Slide the fence along the rail. If it drags across the table, then adjust the foot at the rear of the fence with a 6mm hex wrench to raise the fence off of the table, just enough so that the gap between the fence and the table is even from front to back.
- Slide the fence up against the right hand edge of the miter slot, and lock it in place. Examine how the fence lines up with the miter slot (see **Figure 28**).

Note: It is permissible for the back of the fence to pivot outward not more than $1/64$ " from being parallel to the blade. This creates a slightly larger opening between the fence and the rear of the blade to reduce the risk of workpiece binding or burning as it is fed through the cut. Many woodworkers intentionally set up their fence in this manner. Keep this in mind before adjusting your fence. For more details see **Figure 107 on Page 71**.

- If the fence/miter slot are still parallel with the blade, proceed to **Step Fence Scale**.
- If the fence is not parallel to the blade/miter slot, then you **MUST** adjust the fence, as described in **Fence Adjustments on Page 70**, so that it is parallel to the blade.
- If the miter slot is not parallel with the blade, you must follow the procedures described in **Miter Slot to Blade Parallelism on Page 67**.

Fence Scale

Since the adhesive fence scale will be difficult to remove once it installed, determine whether you will use the pointer window on the right or the left side of the fence before installing the scale.

The pointer window may come pre-installed on the left side of the fence. However, we recommend loosening the mounting screws on the window and re-installing it on the right side of the fence (see **Figure 29**) so workpieces will not cover the pointer window when preparing to cut.



Figure 27. Securing blade.

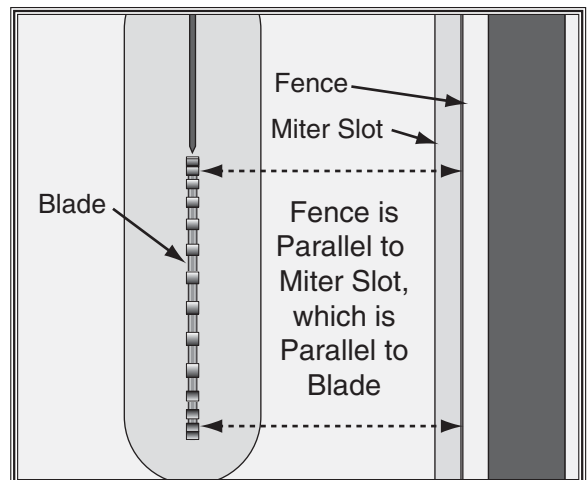

Figure 28. Checking fence parallelism with blade.

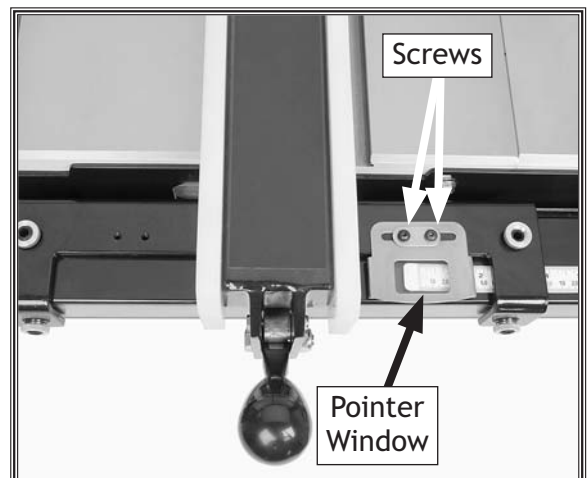

Figure 29. Aligning rail tape with scale pointer.

SETUP

On the Model W1819, if you move the pointer window to the right side of the fence, you may have to trim the last two inches of the scale so it will not protrude past the end of the fence tube.

One option for using the pointer window on the left side of the fence is to use it in conjunction with a small, left-reading scale (not included).

To install the fence scale, do these steps:

1. Slide the fence up against the saw blade and lock it in place.
2. Place the front rail tape scale on the fence tube, making sure it is parallel with the tube and that the "0" end is directly under the red line on the pointer window, as shown in **Figure 29**.
3. Lightly mark the "0" location on the fence tube with a pencil, then remove the fence.
4. Peel the tape and carefully align the "0" mark on the scale with the pencil mark you made on the fence tube.
 - If you make a mistake, loosen the screws on the pointer window, slide the fence against the blade, adjust the pointer window so the red line on the window is over the 0" mark on the tape, then secure the screws.

Blade Guard

1. Re-install the table insert, slide the knurled knob out (see **Figure 30**) and rotate it forward so it engages the upper bracket.
2. Slide the blade guard spreader all the way down into the adjustment block, then rotate the knurled knob so it disengages the bracket and the locking pin engages the hole in the center of the spreader.
3. Give the spreader an upward tug to verify that it is locked.

The blade guard, when properly installed, should look like **Figure 31**, and should pivot freely so it touches the table surface in the down position. It should also swing up high enough to accommodate the workpiece.

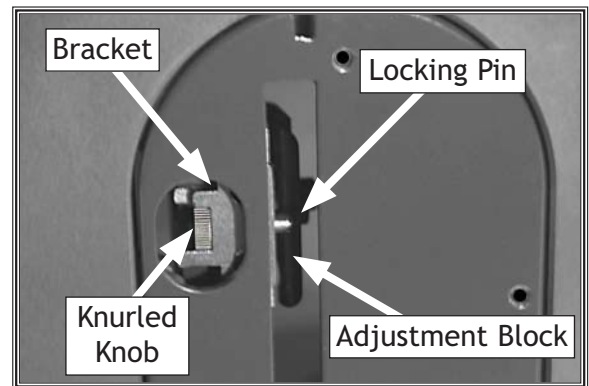

Figure 30. Knurled knob used to secure spreader.



Figure 31. Blade guard installed.

SETUP

4. Adjust the set screws to make sure the table insert is flush with the table (use a straightedge as a guide), then tighten the button head screw to secure the table insert in place.
5. Place a straightedge against the blade and the spreader. When properly aligned, the spreader/riving knife will be parallel with the blade and in the "Alignment Zone," shown in **Figure 32**.
 - If the spreader/riving knife is not inside the alignment zone and not parallel with the blade, then it needs to be adjusted. Proceed to "Adjusting Alignment" on **Page 69**.
 - If the spreader/riving knife is not parallel with the blade, it may be bent. Proceed to "Checking Alignment" on **Page 68** to determine if the spreader/riving knife is bent.

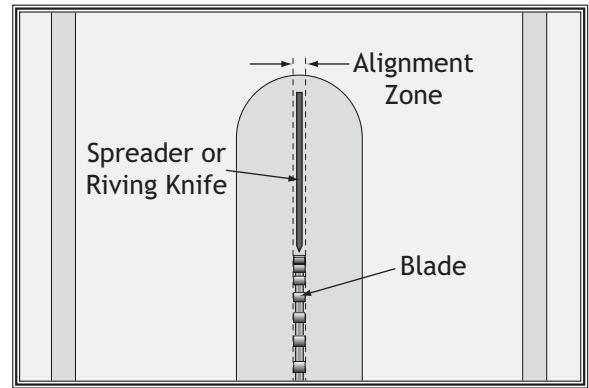

Figure 32. Spreader/riving knife alignment zone.

Dust Collection

Components and Hardware Needed:	Qty
Dust Hose 4" (not included).....	1
Hose Clamps 4" (not included).....	2
Dust Collection System (not included)	1

Recommended CFM at Dust Port: 400 CFM
 Do not confuse this CFM recommendation with the rating of the dust collector. To determine the CFM at the dust port, you must consider these variables: (1) CFM rating of the dust collector, (2) hose type and length between the dust collector and the machine, (3) number of branches or wyes, and (4) amount of other open lines throughout the system. Explaining how to calculate these variables is beyond the scope of this manual. Consult an expert or purchase a good dust collection "how-to" book.

⚠ CAUTION

DO NOT operate the Model W1819 or W1820 without an adequate dust collection system. This saw creates substantial amounts of wood dust while operating. Failure to use a dust collection system can result in short and long-term respiratory illness.

To connect a dust collection hose, do these steps:

1. Fit a 4" dust hose over the dust port, as shown in **Figure 33**, and tightly secure in place with a hose clamp.
2. Tug the hose to make sure it does not come off. **Note:** A tight fit is necessary for proper performance.



Figure 33. Dust hose attached to dust port.

SETUP

Test Run

Once the assembly is complete, test run the machine to make sure it runs properly for regular operations. The test run consists of verifying the following: 1) The motor powers up and runs correctly, and 2) the safety disabling mechanism on the switch works correctly.

If, during the test run, you cannot easily locate the source of an unusual noise or vibration, stop using the machine immediately, then review **Troubleshooting** on **Page 77**. If you still cannot remedy a problem, contact our Tech Support at (360) 734-3482 for assistance.

To test run the machine, do these steps:

1. Make sure you have read the safety instructions at the beginning of the manual and that the machine is fully assembled and set up properly.
2. Make sure all tools and objects used during setup are cleared away from the machine.
3. Connect the machine to the power source.
4. Verify that the machine is operating correctly by turning the machine **ON**.
 - When operating correctly, the machine runs smoothly with little or no vibration or rubbing noises.
 - Investigate and correct strange or unusual noises or vibrations before operating the machine further. Always disconnect the machine from power when investigating or correcting potential problems.
5. Turn the machine **OFF**.
6. Insert the switch disabling pin through the green ON button, as shown in **Figure 34**.
7. Press the green ON button to test the disabling feature on the switch.
 - If the machine does not start, the switch disabling feature is working as designed.
 - If the machine starts, immediately stop the machine. The switch disabling feature is not working correctly. This safety feature must work properly before proceeding with regular operations. Call Tech Support for help.

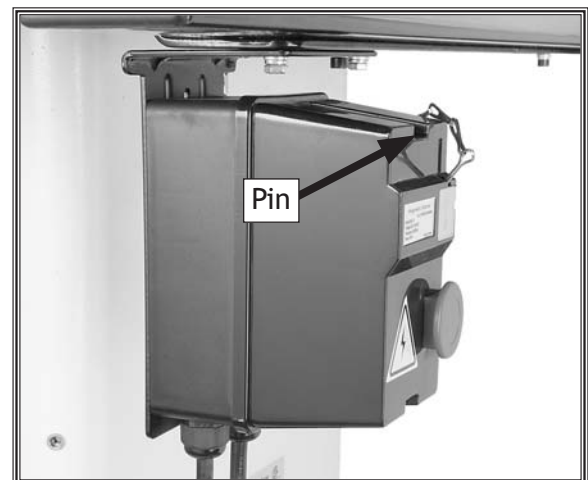

Figure 34. Switch disabling pin inserted into ON button.

OPERATIONS

General

This machine will perform many types of operations that are beyond the scope of this manual. Many of these operations can be dangerous or deadly if performed incorrectly.

The instructions in this section are written with the understanding that the operator has the necessary knowledge and skills to operate this machine. **If at any time you are experiencing difficulties performing any operation, stop using the machine!**

If you are an inexperienced operator, we strongly recommend that you read books or trade articles, or seek training from an experienced Table Saw operator before performing any unfamiliar operations. **Above all, your safety should come first!**

⚠ WARNING



READ and understand this entire instruction manual before using this machine. Serious personal injury may occur if safety and operational information is not understood and followed. DO NOT risk your safety by not reading!

Basic Controls

ON/OFF Switch: Starts and stops the motor.

Safety Pin & Chain: When installed (as shown in Figure 35) disables the switch to prevent accidental startup.

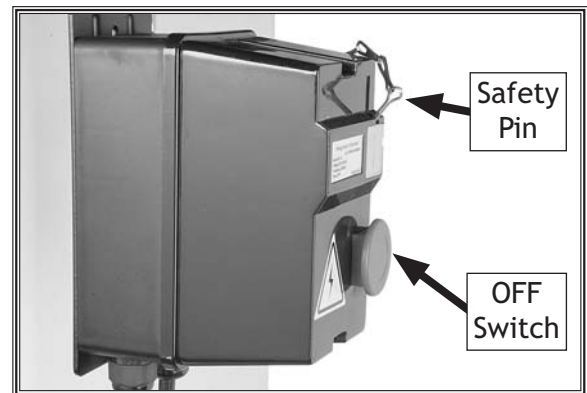

Figure 35. ON/OFF switch disabled.

Blade Tilt: To adjust the blade tilt, loosen the blade tilt lock, turn the blade tilt handwheel to position the blade at the desired angle, then tighten the lock shown in Figure 36.

Blade Height: To set the blade height, unlock the blade height lock, turn the handwheel to set the blade height approximately 1/4" higher than the workpiece, then re-tighten the blade height lock.

Fence Lock: After adjusting the fence to the desired width of cut, lock it in place by firmly pushing the fence lock down until it stops.

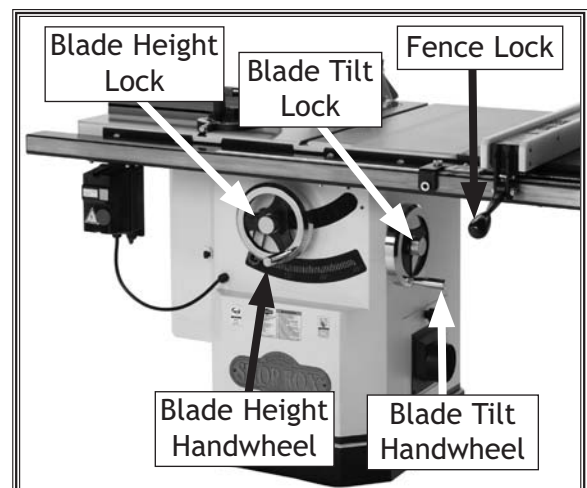

Figure 36. Basic table saw controls.

OPERATIONS

Non-Through & Through Cuts

Non-Through Cuts

A non-through cut is a sawing operation where the blade does not protrude above the top face of the wood stock, as shown in **Figure 37**.

Examples of non-through cuts include dadoes and rabbets. Non-through cuts have a higher risk of injury from kickback because the spreader and blade guard must be removed. When making non-through cuts with a standard blade, the riving knife **MUST** be installed. When making non-through cuts with a dado blade, extreme care, including using multiple light passes must be used, because the blade guard cannot be used.

The following non-through cuts are described in this manual on the pages noted below:

- Dado Cutting: **Page 44**
- Rabbet Cutting: **Page 47**
- Resawing: **Page 49**

Through Cuts

A through cut is a sawing operation in which the workpiece is completely sawn through, as shown in **Figure 38**. Examples of through cuts are rip cuts, cross cuts, miter cuts, and beveled cuts. The blade guard assembly **MUST** be used when performing through cuts.

The following through cuts are described in this manual on the pages noted below:

- Ripping: **Page 40**
- Crosscutting: **Page 41**
- Miter Cuts: **Page 42**
- Blade Tilt & Bevel Cuts: **Page 43**

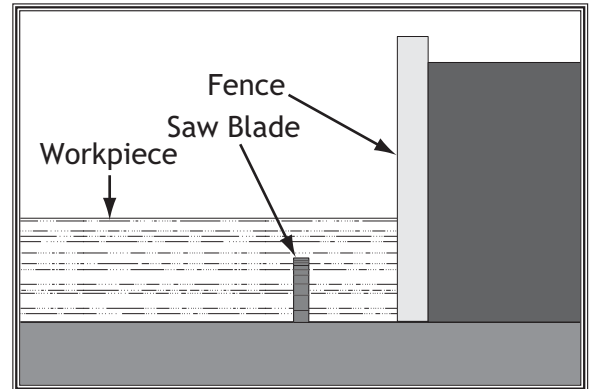

Figure 37. Example of a non-through cut.

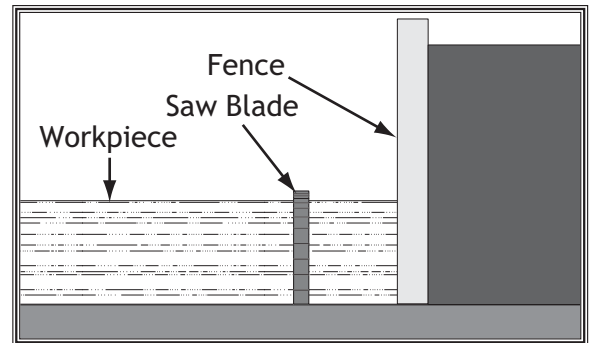

Figure 38. Example of a through cut (blade guard not shown for illustrative clarity).

Blade Selection

Ripping blade features (see Figure 39):

- Best for cutting with the grain of the workpiece.
- 20-40 teeth.
- Flat-top ground tooth profile.
- Large gullets for large chip removal.

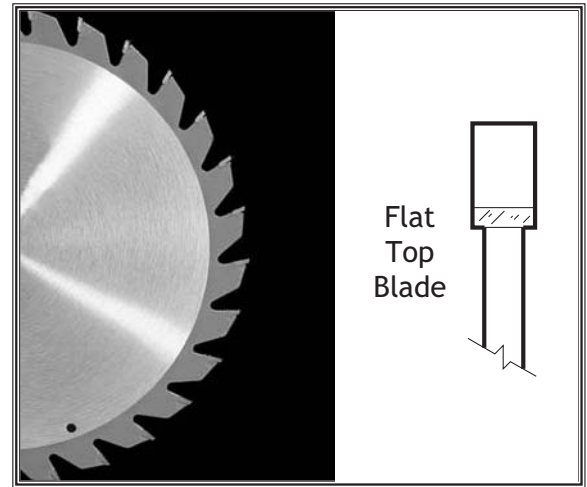

Figure 39. Ripping blade.

Crosscut blade features (see Figure 40):

- Best for cutting across the grain of the workpiece.
- 60-80 teeth.
- Alternate top bevel tooth profile.
- Small hook angle and a shallow gullet.



Figure 40. Crosscutting blade.

Combination blade features (see Figure 41):

- Adequate for cutting both with and across the grain.
- 40-50 teeth.
- Alternate top bevel and flat, or alternate top bevel and raker tooth profile.
- Teeth are arranged in groups of five.
- Gullets are small and shallow within the groups of five teeth, similar to a cross-cut blade; then large and deep between each group of five, like a ripping blade.

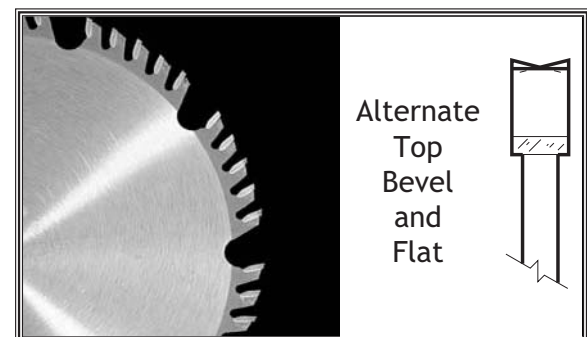

Figure 41. Combination blade.

Laminate blade features (see Figure 42):

- Best for cutting plywood or veneer.
- 40-80 teeth.
- Triple chip tooth profile.
- Very shallow gullet.

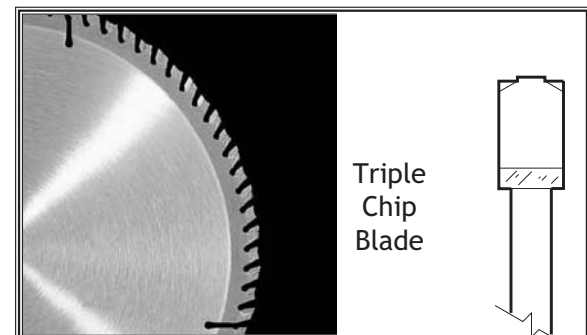

Figure 42. Laminate blade.

OPERATIONS

Dado Blades (see Figure 43):

There are two types of dado blades: stacked and wobble.

- Stacked Dado Blade:** These dedicated dado cutting blade sets consist of up to 8 individual blades. Multiple cutters are "stacked" between two outside blades. The width of the dado is determined by the combination of cutters that are "stacked" together. The dado is cut in a single pass leaving a smooth and square channel in the face of the workpiece. Stacked dado blades are the most expensive option, but are worth considering if your projects require a lot of visible dado cuts. A stacked dado blade is shown in Figure 43.
- Wobble Dado Blade:** Also a dedicated dado blade, a wobble blade usually consists of a single blade that is tilted on the arbor shaft while it is spinning. The channel is cut in the face of the workpiece as the blade passes through its pre-adjusted width of travel. Wobble blades are an inexpensive option when visibly pleasing channels are not a concern.

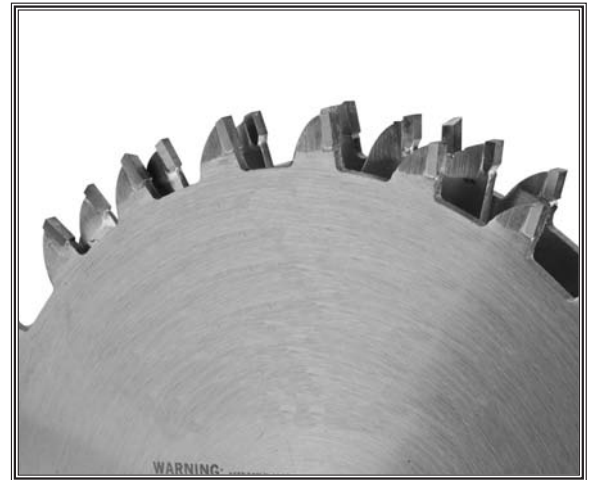

Figure 43. Stacked dado blade.

Thin Kerf Blade

A blade with a kerf or thickness that is thinner than a standard blade. Since thin kerf blades are typically the same thickness of the spreader or riving knife—and in some cases thinner—we DO NOT recommend that they be used on this saw due to the increased risk of kickback. The acceptable kerf range is 0.102"- 0.126" (2.6mm-3.2mm).

Note: *This section on blade selection is by no means comprehensive. Always follow the saw blade manufacturer's recommendations to ensure safe and efficient operation of your table saw.*

Blade Installation

⚠ CAUTION

The saw blade is sharp. Use extra care or wear gloves when handling the blade or working near it.

Review this section, even if your saw blade came pre-installed.

To install the blade, do these steps:

1. DISCONNECT THE SAW FROM POWER!
2. Put on heavy leather gloves and raise the arbor all the way up.
3. Remove the table insert and blade guard/riving knife, depending on what is installed.
4. Use the arbor wrenches to loosen and remove the arbor nut, flange, and blade.

Note: The arbor nut has right hand threads; turn it counterclockwise to loosen.

5. Slide the blade over the arbor with the teeth facing the front of the saw, as shown in **Figure 44**.
6. Re-install the arbor flange and the arbor nut (see **Figure 45**), and tighten them against the blade with the wrenches included with the saw. DO NOT over-tighten.

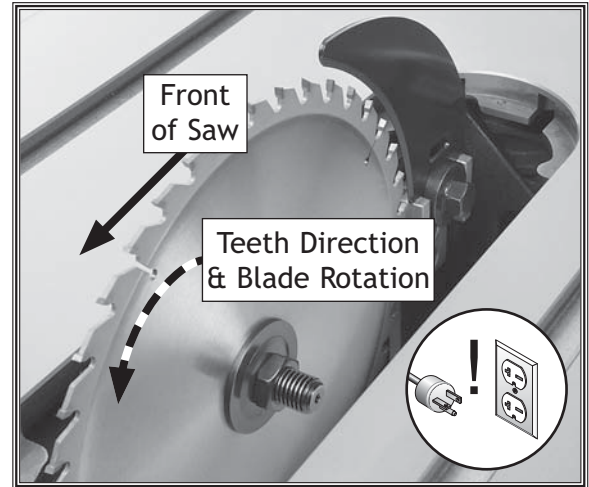

Figure 44. Example of correct blade direction.

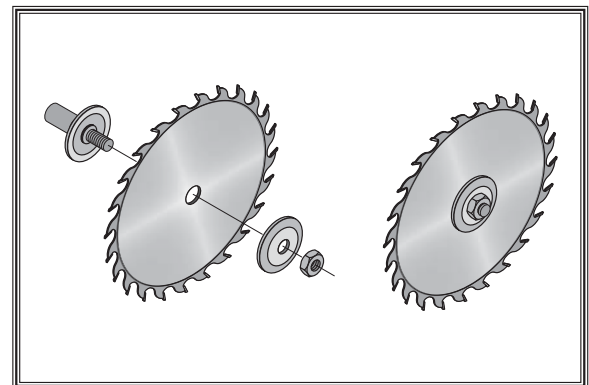

Figure 45. Blade installation.

Blade Guard Assembly

The term "blade guard" refers to the assembly that consists of the clear polycarbonate shield, the spreader, and the anti-kickback pawls on each side of the spreader (Figure 46). Each of these components have important safety functions during the operation of the saw.

Guard

The clear polycarbonate guard allows the operator to see the blade cut the workpiece during operation. This guard is designed to lift as the workpiece is pushed into the blade and remain in contact with the workpiece throughout the entire cut.

The guard reduces injury risk by providing a barrier around the blade that prevents accidental contact and contains flying wood chips.

To ensure that the guard does its job effectively, it must always be in the downward position against the table in the resting position during idle operation, and the hinge mechanism must be maintained in good working condition so the guard can freely pivot up and down to accommodate the height of the workpiece and return to the table surface.

Spreader

The spreader is a metal plate that prevents the newly cut kerf of the workpiece from pinching the backside of the blade, causing kickback. The spreader also acts as a barrier behind the blade to shield hands from being pulled into the blade if a kickback occurs.

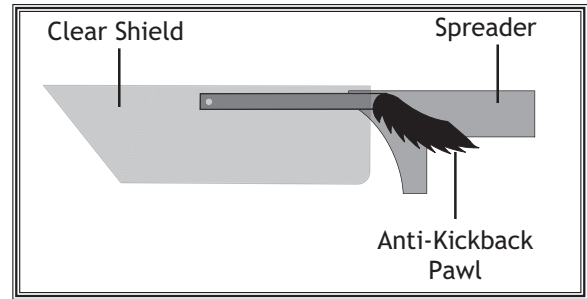

Figure 46. Blade guard assembly components.

⚠ WARNING

In order to work properly, the spreader cannot be bent or misaligned with the blade. If the spreader gets accidentally bent, take the time to straighten it or just replace it. Using a bent or misaligned spreader will increase the risk of kickback!

⚠ CAUTION

To ensure that the blade spreader works safely, the following requirements **MUST** be met when installing new blades:

- Blade Diameter: 10"
- Spreader Thickness: 0.1" (2.5mm)
- Required Blade Body Thickness (excluding teeth): 0.071-0.094" (1.8-2.4mm)
- Required Blade Kerf Thickness: 0.102"- 0.126" (2.6mm-3.2mm)

The spreader **MUST** be aligned/adjusted to the blade. *These requirements are not applicable to dado blades.*

Anti-Kickback Pawls

The anti-kickback pawls allow the workpiece to travel in only one direction. If the workpiece moves backwards, such as during a kickback, the pawls will dig into the workpiece to slow or stop it.

To work properly, the pawls must return to their bottom-most position after pivoting, as shown in **Figure 47**, and they must not be engaged in the arresting hooks. If the pawls fail to return to the bottom position, the pivot spring may have been dislodged or broken and will need to be fixed/replaced.

Disabling Pawls

To disable the pawls, rotate the arresting hooks downward, then place the pawls on each of the hooks, as shown in **Figure 48**.

Use your best judgment before retracting the pawls, as they are provided for your safety. Certain situations could warrant retracting the pawls. For example, you might retract the pawls if you are concerned about them scratching a delicate workpiece, or if you believe that they will obstruct a narrow workpiece and cause feeding difficulty or loss of control.

Enabling Pawls

To enable the pawls, lift up on each pawl and move them outward and down until they both touch the table surface, as shown in **Figure 47**.

When to Use the Blade Guard

The blade guard assembly **MUST** always be installed on the saw for all normal through cuts (those where the blade cuts all the way through the thickness of the workpiece).

When Not to Use the Blade Guard

The blade guard cannot be used on any non-through cuts (those in which the blade does not cut all the way through the thickness of the workpiece).

Sometimes the blade guard or its components can get in the way when cutting very narrow workpieces or other specialized cuts. Because the blade guard is provided to decrease your risk of injury, it should not be used if it gets in the way of making a safe cut. Use good judgment!

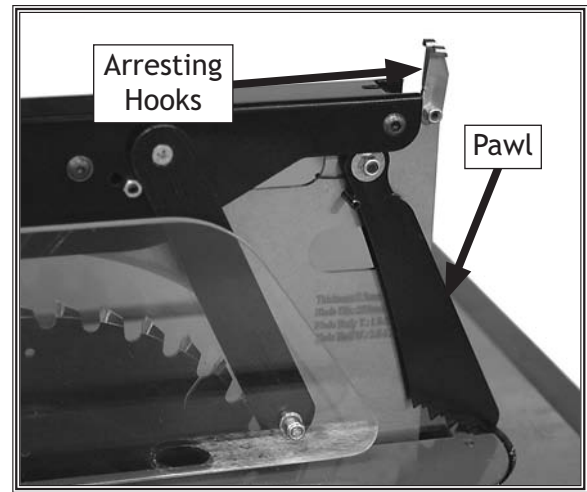

Figure 47. Pawls in return position.

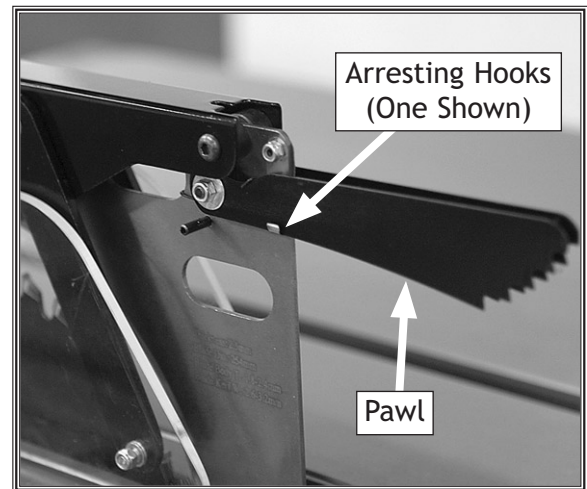

Figure 48. Pawl disabled.

⚠ WARNING

We do not recommend disabling the pawls during normal operations unless absolutely necessary. In most situations, disabling the pawls will increase your risk of serious personal injury in the event of a kickback.

NOTICE

Whenever the blade guard cannot be used, the riving knife must be installed.

Riving Knife

The riving knife works in the same manner as the spreader on the blade guard assembly. It is a metal plate that prevents the newly cut workpiece from pinching the backside of the blade and causing kickback.

The key difference between the spreader and the riving knife is that the riving knife mounts below the blade's highest point of rotation, as shown in **Figure 49**.

The height difference between the riving knife and the blade allows the workpiece to pass over the blade during non-through cuts (those in which the blade does not cut all the way through the thickness of the workpiece).

The riving knife acts as a barrier behind the blade to reduce the risk of hands being pulled into the blade if a kickback occurs. The riving knife must be kept within the range shown in **Figure 50**. For that reason, we only recommend using a 10" blade for operations that require use of the riving knife.

How to Install the Riving Knife

The riving knife is installed in a similar manner to the blade guard and spreader. Refer to Blade Guard on **Page 36** for installation instructions.

When to Use the Riving Knife

Use the riving knife for all non-through cuts made with a standard table saw blade (i.e., dados or rabbet cuts in which a dado blade is NOT used, and when using a tenoning jig). Also, use the riving knife for those special operations where the blade guard or its components get in the way of safe operation, such as with very narrow cuts.

When Not to Use the Riving Knife

The riving knife CANNOT be used with a dado blade that has a diameter smaller than 10". Otherwise, the riving knife height will exceed the blade height and the workpiece will hit the riving knife during the cut, forcing the operator into a dangerous situation of trying to turn the saw off with the workpiece stuck halfway through the cut.

In addition, although it is possible to use the riving knife for through cutting operations, the blade guard assembly offers far more injury protection and risk reduction than the riving knife. Therefore, we **strongly recommend** that you use the blade guard assembly instead of the riving knife for through cuts.

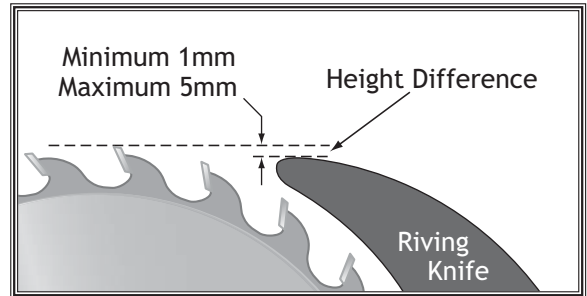

Figure 49. Height difference between riving knife and blade.

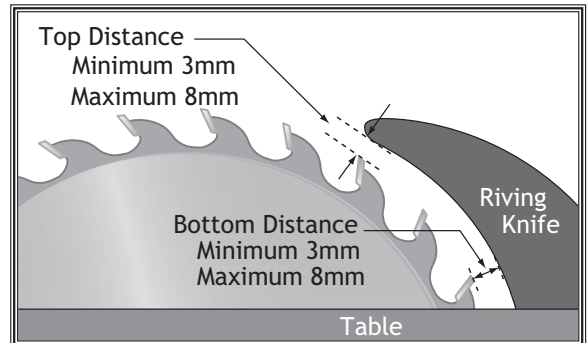

Figure 50. Allowable top and bottom distances between riving knife and blade.

⚠️ WARNING

In order to work properly, the riving knife cannot be bent or misaligned with the blade. If the riving knife gets accidentally bent, take the time to straighten it or just replace it. Using a bent or misaligned riving knife will increase the risk of kickback!

⚠️ CAUTION

To ensure riving knife works safely, the following requirements **MUST** be met when installing new blades:

- Blade Diameter: 10"
 - Riving Knife Thickness: 0.1" (2.5mm)
 - Required Blade Body Thickness (excluding teeth): 0.071-0.094" (1.8-2.4mm)
 - Required Blade Kerf Thickness: 0.102"- 0.126" (2.6mm-3.2mm)
- Riving knife **MUST** be aligned to blade; *These Requirements do not apply to dado blades.*

Workpiece Inspection

Some workpieces are not safe to cut or may require modification before they can be made safe to cut.

Before cutting, get in the habit of inspecting all workpieces for the following:

- **Material Type:** This machine is intended for cutting natural and man-made wood products, laminate covered wood products, and some plastics. Cutting drywall or cementitious backer board creates extremely fine dust and may reduce the life of the bearings. This machine is NOT designed to cut metal, glass, stone, tile, etc.; cutting these materials with a table saw may lead to injury.
- **Foreign Objects:** Nails, staples, dirt, rocks and other foreign objects are often embedded in wood. While cutting, these objects can become dislodged and hit the operator, cause kickback, or break the blade, which might then fly apart. Always visually inspect your workpiece for these items. If they can't be removed, DO NOT cut the workpiece.
- **Large/Loose Knots:** Loose knots can become dislodged during the cutting operation. Large knots can cause kickback and machine damage. Choose workpieces that do not have large/loose knots or plan ahead to avoid cutting through them.
- **Wet or "Green" Stock:** Cutting wood with a moisture content over 20% causes unnecessary wear on the blades, increases the risk of kickback, yields poor results.
- **Excessive Warping:** Workpieces with excessive cupping, bowing, or twisting are dangerous to cut because they are unstable and often unpredictable when being cut. DO NOT use workpieces with these characteristics!
- **Minor Warping:** Workpieces with slight cupping can be safely supported if the cupped side is facing the table or the fence.

Ripping

"Ripping" means cutting with the grain of a natural wood workpiece. In other man-made materials such as MDF or plywood, ripping simply means cutting lengthwise.

To make a rip cut, do these steps:

1. Review Preventing Kickback on Page 13 and take the necessary precautions to prevent kickback.
 2. If using natural wood, joint one long edge of the workpiece on a jointer.
 3. DISCONNECT THE SAW FROM POWER!
 4. Ensure that the blade guard/spreader is installed.
 5. Set the fence to the desired width of cut on the scale.
 6. Adjust the blade height so the highest saw tooth protrudes approximately 1/4" above the workpiece.
 7. Set up safety devices such as featherboards or other anti-kickback devices.
 8. Rotate the blade by hand to make sure it does not come into contact with any of the safety devices.
 9. Plug the saw into the power source, turn it **ON**, and allow it to reach full speed.
- Note: The jointed edge of the workpiece must slide against the fence during the cutting operation.*
10. Use a push stick to feed the workpiece through the saw blade, as shown in Figure 51, until the workpiece is completely past the saw blade.

⚠ WARNING

Serious injury can be caused by kickback. Kickback is a high-speed expulsion of stock from the table saw toward an operator. The operator or bystanders may be struck by flying stock, or the operator's hands can be pulled into the blade during the kickback.



Figure 51. Typical ripping operation.

⚠ WARNING

Keep the blade guard installed and in the down position. Failure to do this could result in serious personal injury or death.

⚠ WARNING

Turn **OFF** the saw and allow the blade to come to a complete stop before removing the cut-off piece. Failure to follow this warning could result in serious personal injury.

OPERATIONS

Crosscutting

"Crosscutting" means cutting across the grain of a natural wood workpiece. In other man-made materials, such as MDF or plywood, crosscutting means cutting across the width of the workpiece.

To make a crosscut using the miter gauge, do these steps:

1. DISCONNECT THE SAW FROM POWER!
2. Ensure that the blade guard/spreader is installed.
3. Move the rip fence aside and position the miter gauge, adjusted to 90°, in a miter slot.
4. Adjust the blade height so the teeth protrude approximately 1/4" above the workpiece.
5. Slide the miter gauge near the blade and adjust the workpiece so the blade will cut on the waste side of the line.
6. Plug in the table saw, turn it **ON**, and allow it to reach full speed.
7. Hold the workpiece firmly against the face of the miter gauge (see **Figure 52**) and ease it through the blade until the workpiece is completely past the saw blade.

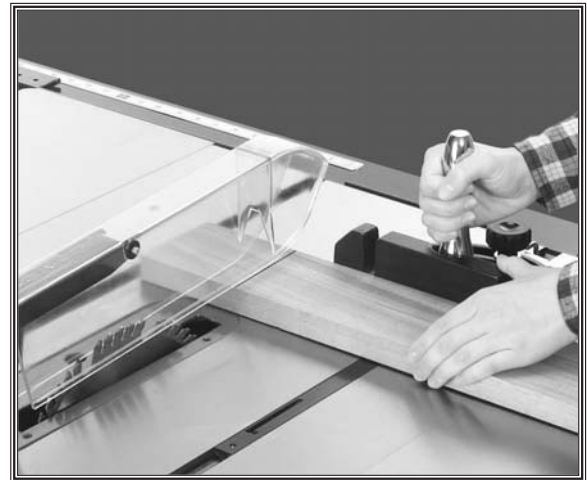
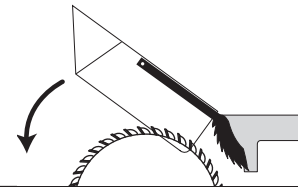

Figure 52. Typical crosscutting operation.

WARNING

Turn **OFF** the saw and allow the blade to come to a complete stop before removing the cut-off piece. Failure to follow this warning could result in serious personal injury.

WARNING



Keep the blade guard installed and in the down position. Failure to do this could result in serious personal injury or death.

Miter Cuts

A miter is an angled crosscut. Miters are usually cut in the same manner as crosscuts, using the miter gauge and a predetermined mark on the workpiece.

To perform a miter cut, do these steps:

1. DISCONNECT THE SAW FROM POWER!
2. Ensure that the blade guard/spreader is installed.
3. Determine the angle of your cut. If the angle needs to be very precise, use a protractor to set the miter gauge to the blade.
4. Place the face of the miter gauge against the edge of the workpiece and place the bar across the face of the workpiece. Use the bar as a guide to mark your cut, as shown in **Figure 53**.
5. Place the miter gauge back into the slot and hold the workpiece firm against the miter gauge body. Slide the miter gauge near the blade and adjust the workpiece so the blade will cut on the waste side of the line.
6. Proceed to make the cut in the same manner as described in the **Crosscutting** instructions on **Page 41**.



Figure 53. Example of marking miter line.

OPERATIONS

Miter Fence

The miter fence provides greater workpiece support than the miter gauge alone, especially for longer workpieces.

Simply loosen the lock levers shown in **Figure 54**, slide the miter fence in the needed direction for the cutting operation, then tighten the levers. Make sure the miter fence does not contact the blade guard or blade when moved through its full range of travel.

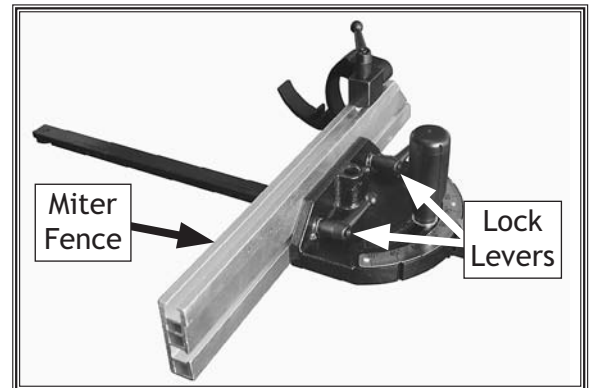

Figure 54. Miter fence lock levers.

Flip Stop

The flip stop can be positioned anywhere along the top of the miter fence and secured in place with a lock lever (see **Figure 55**), the same distance away from the blade as your desired width of cut.

The flip stop can be used in the down position to make multiple cuts of the same width. It can be pivoted (hence the name “flip”) out of the way to allow longer workpieces to be cut, then pivoted back down to make additional cuts at the specified cutting width.

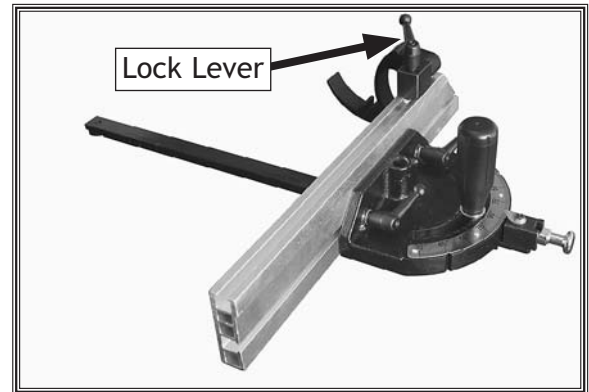

Figure 55. Flip stop lock lever.

Blade Tilt & Bevel Cuts

When the blade tilt stop bolts are properly adjusted, as described on **Page 65**, the blade tilt handwheel allows the operator to tilt the blade to the left, anywhere between 0° and 45°. This is used most often when cutting bevels or compound miters. **Figure 56** shows an example of the blade when tilted to 45°.

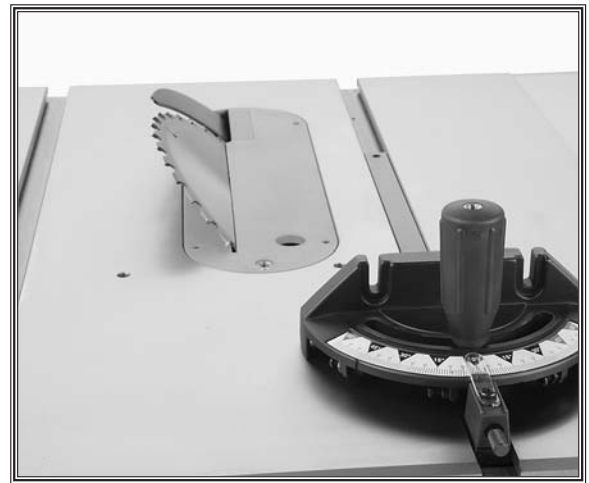

Figure 56. Blade tilted to 45° for bevel cutting on a typical table saw.

Dado Cutting

Commonly used in furniture joinery, a dado is a straight channel cut in the face of the workpiece. Dadoes can be cut using either a dedicated dado blade or a standard saw blade. **Figure 57** shows a cutaway view of a dado cut being made with a dado blade.

The included dado table insert must be installed and used when a dado blade is installed—unless a zero clearance table insert is used instead.

The table saw motor is pushed to its limits when making a dado cut with a dado blade. If the motor starts to bog down, slow down your feed rate, reduce the depth of cut and make multiple shallow passes.

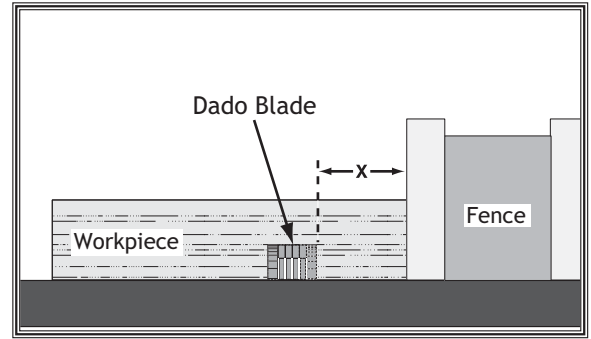

Figure 57. Example of a dado cut with a dado blade.

Installing a Dado Blade

1. DISCONNECT THE SAW FROM POWER!
2. Remove the table insert, the blade guard assembly or riving knife, and the saw blade.
3. Attach and adjust the dado blade system according to the dado blade manufacturer's instructions
4. Install the dado insert.

WARNING

Dado blades have a higher risk of kickback than normal blades because their large size applies stronger forces to the workpiece. This risk increases relative to the depth and width of the cut. To minimize your risk of serious personal injury, ensure that stock is flat and straight, and make multiple light cuts (rather than one deep cut) to achieve the desired cutting depth.

WARNING

DO NOT make a through-cut with a dado blade. Dado blades are not designed for through cuts. Failure to follow this warning could result in serious personal injury.

Cutting Dados with a Dado Blade

Because dado blades are so much wider than standard blades, they place a much greater amount of force against the workpiece when cutting.

To avoid injury, dado cuts require a much slower feed rate than normal cuts, and they are best done with multiple light cuts that get progressively deeper until the desired depth of cut is achieved, as demonstrated in **Figure 58**.

To cut a dado with a dado blade, do these steps:

1. Adjust the dado blade to the desired depth of cut.
2. Adjust the distance between the fence and the inside edge of the blade, as shown in **Figure 57** on **Page 44**.
 - If dadoing across the workpiece, use the miter gauge and carefully line up the desired cut with the dado blade. **DO NOT** use the fence in combination with the miter gauge.
3. Reconnect the saw to the power source.
4. Turn the saw **ON**. The blade should run smooth, with no vibrations.
5. When the blade has reached full speed, perform a test cut with a scrap piece of wood.
6. If the cut is satisfactory, repeat the cut with the actual workpiece.

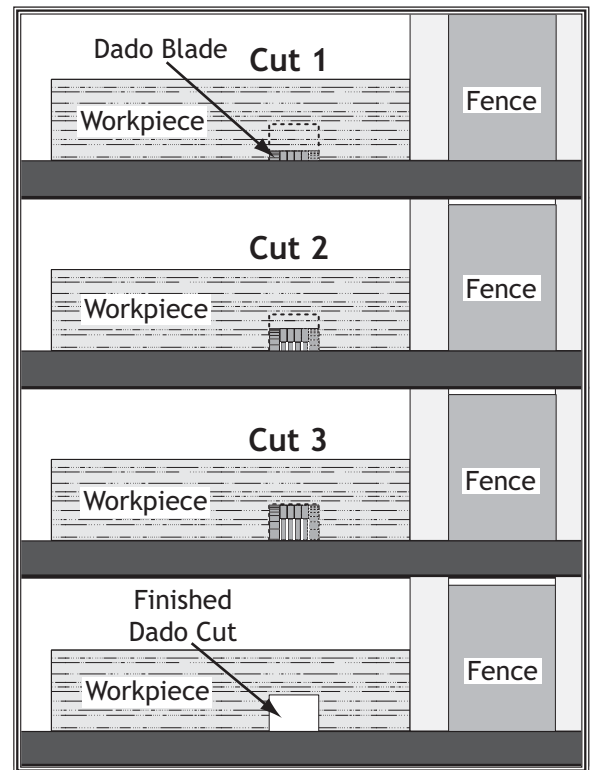

Figure 58. Example of dado being cut with multiple light cuts, instead of one deep cut.

Cutting Dados with a Standard Blade

A ripping blade is typically the best blade to use for cutting dados when using a standard blade because it removes sawdust very efficiently. See **Page 33** for blade details.

To use a standard saw blade to cut dados, do these steps:

1. DISCONNECT THE SAW FROM POWER!
 2. Ensure that the riving knife and standard table insert are installed and properly adjusted.
 3. Mark the width of the dado cut on the workpiece. Include marks on the edge of the workpiece so the cut path can be aligned when the workpiece is lying on the table.
 - If dadoing across the workpiece, use the miter gauge to support the workpiece, and align the blade to cut one of the dado sides. DO NOT use the fence in combination with the miter gauge.
 - If dadoing the length of a workpiece, align the blade to cut one of the dado sides as shown in **Figure 59**.
 5. Reconnect the saw to the power source and turn the saw **ON**. Allow the blade to reach full speed.
 6. Perform the cutting operation.
 7. Re-adjust the fence so the blade is aligned with the other edge of the intended dado channel (**Figure 60**).
- Note:** Be sure to keep the cuts within your marks; otherwise, the dado will be too big.
8. Continue making cuts toward the center of the dado until the dado is complete (see **Figure 61**).

WARNING

The danger of kickback increases relative to the depth and width of a cut. Reduce the risk of kickback by making multiple passes to achieve the desired depth of cut. Failure to follow these warnings could result in serious personal injury.

CAUTION

Always use push sticks, featherboards, push paddles and other safety accessories whenever possible to increase safety and control during operations that require the blade guard and spreader to be removed from the saw. ALWAYS replace the blade guard after dadoing is complete.

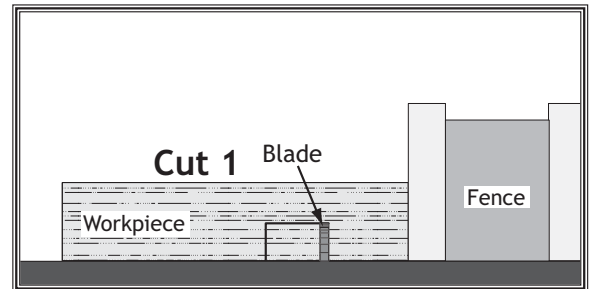

Figure 59. Single-blade dado first cut.

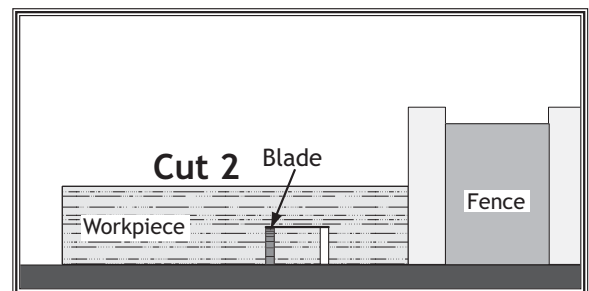

Figure 60. Single-blade dado second cut.

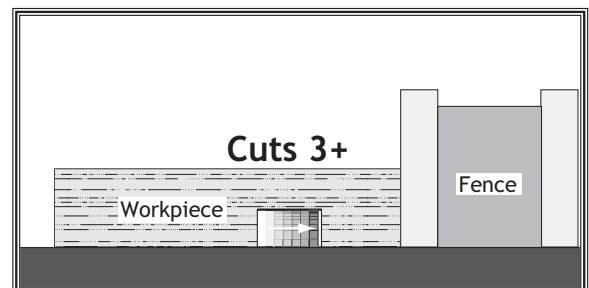

Figure 61. Additional cuts.

Rabbet Cutting

Commonly used in furniture joinery, a rabbet is an L-shaped groove cut in the edge of the workpiece. Rabbets can be cut with either a dado blade or a standard saw blade.

Rabbet cutting on the edge of the workpiece requires a sacrificial fence attachment as shown in **Figure 62**. Make the sacrificial fence the same length as the fence and $\frac{3}{4}$ " thick. Attach it to the fence with screws or clamps, making sure they are all secure and tight. Raise the blade into the sacrificial fence to the height needed.

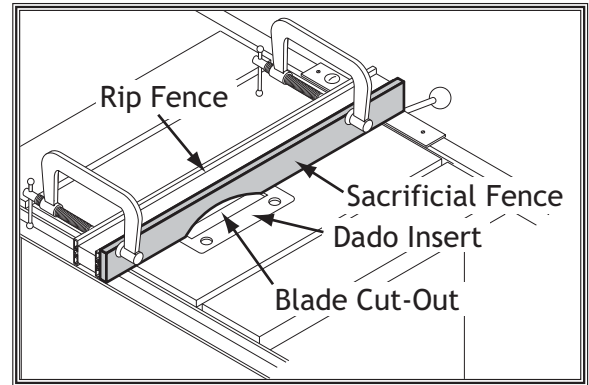

Figure 62. Sacrificial fence.

Cutting Rabbets with Dado Blade

1. DISCONNECT THE SAW FROM POWER!
2. Adjust the dado blade to the height needed for the rabbeting operation. When cutting deep rabbets, take more than one pass to reduce the risk of kickback.
3. Adjust the fence and align the workpiece to perform the cutting operation, as shown in **Figure 63**.

⚠ CAUTION

You may experience kickback during this procedure. Stand to the side of the blade and wear safety glasses or a face shield to prevent injury when cutting rabbets.

⚠ WARNING

Dado blades have a higher risk of kickback than normal blades because their larger size applies stronger force to the workpiece. This risk increases relative to the depth and width of the cut. To minimize your risk of serious personal injury, ensure that the stock is flat and straight, and make multiple light cuts (rather than one deep cut) to achieve the desired cutting depth.

⚠ CAUTION

Always use push sticks, featherboards, push paddles and other safety accessories whenever possible to increase safety and control during operations which require that the blade guard and splitter must be removed from the saw. ALWAYS replace the blade guard after dadoing is complete.

4. Reconnect the saw to the power source and turn the saw **ON**. When the blade has reached full speed, perform a test cut with a scrap piece of wood.
 - If the cut is satisfactory, repeat the cut with the final workpiece.

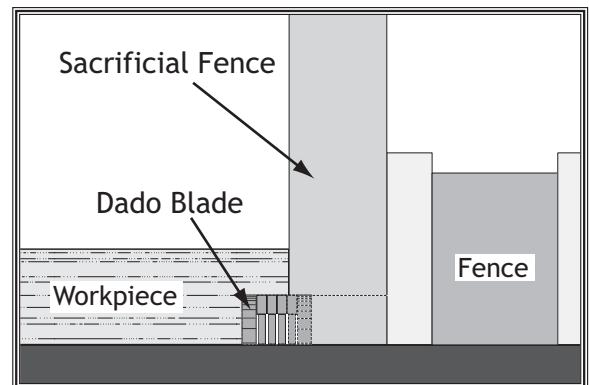

Figure 63. Rabbet cutting with a dado blade

OPERATIONS

Cutting Rabbets with Standard Blade

A ripping blade is typically the best blade to use for cutting rabbets when using a standard blade because it removes sawdust very efficiently (see **Page 33** for blade details about ripping blades). Also, a sacrificial fence is not required when cutting rabbets with a standard blade.

To cut a rabbet with a standard blade, do these steps:

1. DISCONNECT THE SAW FROM POWER!
2. Ensure that the riving knife and standard table insert are installed.
3. Mark the width of the rabbet cut on the edge of the workpiece, so you can clearly identify the intended cut.
4. Raise the blade up to the desired depth of cut (depth of rabbet channel desired). When cutting deep rabbets, take more than one pass to reduce the risk of kickback.
5. Stand the workpiece on edge, as shown in **Figure 64**, then adjust the fence so the blade is aligned with the inside of your rabbet channel.
6. Reconnect the saw to the power source and turn the saw **ON**. When the blade has reached full speed, perform a test cut with a scrap piece of wood.
 - If the cut is satisfactory, repeat the cut with the final workpiece.
7. Lay the workpiece flat on the table, adjust the saw blade height to intersect with the first cut, as shown in **Figure 65**, then perform the second cut to complete the rabbet.

WARNING

The danger of kickback increases relative to the depth of a cut. Reduce the risk of kickback by making multiple passes to achieve the desired depth of cut. Failure to follow these warnings could result in serious personal injury.

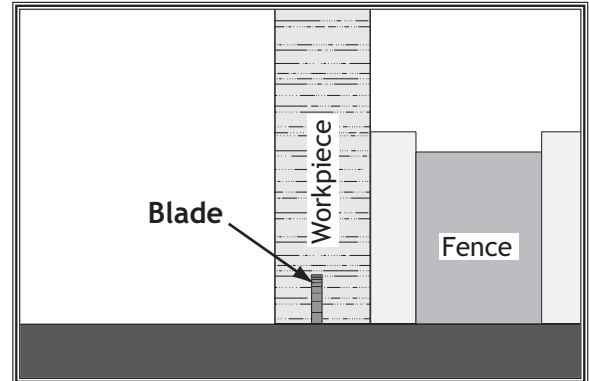

Figure 64. Rabbet cutting with a standard blade.

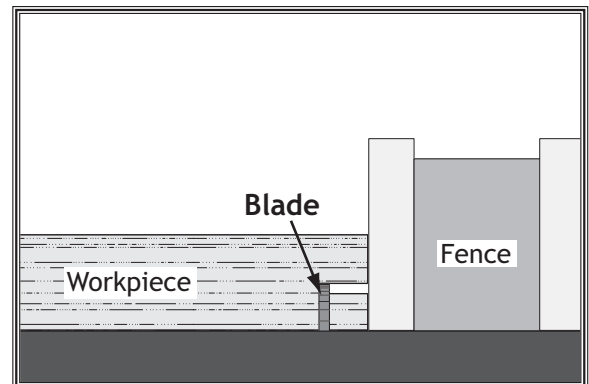

Figure 65. Rabbet cutting with a standard blade.

Resawing

Resawing is the process of cutting a thick piece of stock into one or more thinner pieces. Although resawing can be done with a table saw, we strongly recommend that you use a bandsaw instead.

A bandsaw is the ideal machine for resawing, and resawing with one is fairly easy and safe. A table saw is not intended for resawing, and resawing with one is difficult and dangerous due to the increased risk of kickback from binding and deep cuts, and the increased risk of injury from having to remove the guard.

If you insist on resawing with a table saw, DO NOT do so without using a resaw barrier and wearing a full face shield. The following instructions describe how to build a resaw barrier and add an auxiliary fence to your standard fence, to reduce the risk injury from resawing on a table saw.

Note: This table saw can only resaw wood that is less than $6\frac{3}{8}$ " tall.

WARNING

Resawing on a table saw increases the chances of kickback. Serious injury can be caused by kickback. Kickback is a high-speed expulsion of stock from the table saw toward an operator. The operator or bystanders may be struck by flying stock, or the operator's hands can be pulled into the blade during kickback.

WARNING

Resawing operations require proper procedures to avoid serious injury. Extra care must be taken to prevent kickback when resawing. Any tilting or movement of the workpiece away from the fence will cause kickback. Be certain that stock is flat and straight. Failure to follow these warnings could result in serious personal injury.

Making Resaw Barrier

The resaw barrier acts in tandem with the rip fence when resawing to provide tall support for the workpiece to minimize the probability of it binding against the blade and causing kickback.

Tools Needed for the Resaw Barrier:

Table Saw1
 Jointer and Planer Recommended
 Clamps2 Minimum
 Drill and Drill Bits.....1

Components Needed for the Resaw Barrier:

Wood* $\frac{3}{4}$ " x 6" x Length of Table Saw Fence.....1
 Wood* $\frac{3}{4}$ " x 3" x Length of Table Saw Fence.....1
 Wood Screws #10 x 2"4
 Wood Glue As Needed

* Only use furniture grade plywood, kiln dried hardwood, or UHMW plastic to prevent warping.

To build the resaw barrier, do these steps:

1. Cut your wood pieces to the size specified above. If you are using hardwood, cut the pieces oversize, then joint and plane them to the correct size to make sure they are square and flat.
2. Pre-drill and countersink 4 holes approximately $\frac{3}{8}$ " from the bottom of the 6" tall board. These will be use as pilot holes when attaching the board to another piece in the next step.
3. Glue the end of the 3" board, then clamp the boards at a 90° angle with the larger board in the vertical position, as shown in **Figure 66**, fasten together with the wood screws.

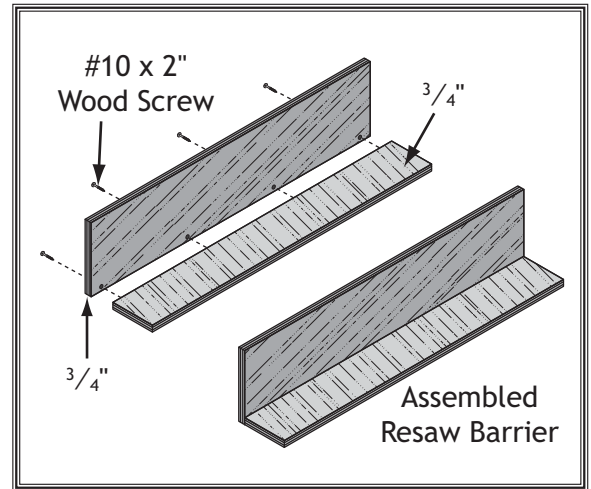

Figure 66. Clamping the resawing barrier.

Auxiliary Fence

The auxiliary fence is necessary if you are resawing a workpiece that is taller than it is wide. It should be no less than $\frac{1}{2}$ " shorter than the board to be resawn.

Components Needed for the Auxiliary Fence:

Hardwood or Plywood $\frac{3}{4}$ " x (Height) x Length of Table Saw Fence.....1

Tools Needed for the Resaw Barrier:

Table Saw1
 Jointer and Planer Recommended
 Clamps2 Minimum

To build the auxiliary fence, do these steps:

1. Cut the auxiliary fence board to size. If you are using hardwood, cut the board oversize, then joint and plane the board to the correct size to make sure the board is square and flat.

Note: Only use furniture grade plywood or kiln dried hardwood to prevent warping.

2. Unthread the fence face mounting hardware and remove the fence face from the fence assembly.
3. Place the auxiliary fence next the fence face you removed in **Step 1**, mark the location of the nine mounting holes on the auxiliary fence, then drill the holes.
4. Use the mounting hardware that had previously attached the fence face to attach the auxiliary fence. The end result should be similar to **Figure 67**.

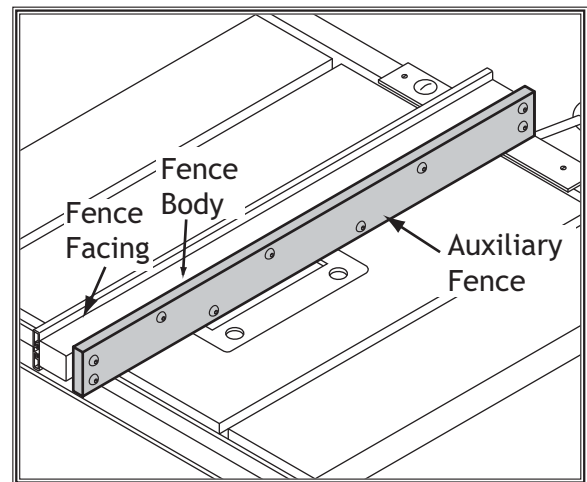

Figure 67. Auxiliary fence.

Resawing Operations

The table saw motor is pushed to its limits when resawing. If the motor starts to bog down, slow down your feed rate. Motor overloading and blade wear can be reduced by using a ripping blade. Ripping blades are designed to clear the sawdust quickly.

Components Needed for Resawing:

Zero Clearance Insert	1
Ripping Blade 10"	1
Clamps	2
Shop Made Auxiliary Fence	1
Shop Made Resaw Barrier	1

To perform resawing operations, do these steps:

1. DISCONNECT THE SAW FROM POWER!
2. Remove the standard table insert and the blade guard assembly.
3. Install a ripping blade and the riving knife, lower the blade below the table, then install a zero clearance table insert.

⚠ WARNING

You may experience kickback during this procedure. Stand to the side of the blade and wear a full face shield to prevent injury when resawing.

OPERATIONS

- Attach the auxiliary fence to the standard fence and set it to the desired width.

Note: When figuring out the correct width, do not forget to account for blade kerf and the inaccuracy of the fence scale while the auxiliary fence is installed. Typically it is best to use a measuring tape to set the fence.

- Place the workpiece against the auxiliary fence and slide the resaw barrier against the workpiece, as shown in **Figure 68**. Now clamp the resaw barrier to the top of the table saw at both ends.

- Slide the workpiece over the blade to make sure it moves smoothly, then remove the workpiece.

- Raise the blade approximately an inch, or close to half the height of the workpiece (**Figure 69**), whichever is less.

- Plug in the table saw, turn it **ON**, and use a push stick or push block to feed the workpiece through the blade, using a slow and steady feed rate.

- Flip the workpiece end for end, keeping the same side against the fence, and run the workpiece through the blade.

- Repeat **Steps 7-9** until the blade is close to half of the height of the board to be resawn. The ideal completed resaw cut will leave a $\frac{1}{8}$ " connection when the resawing is complete as shown in **Figure 69**. Leaving a $\frac{1}{8}$ " connection will reduce the risk of kickback.

- Turn **OFF** the table saw, then separate the parts of the workpiece and hand plane the remaining ridge to remove it.

- When finished resawing, remove the resaw barrier and auxiliary fence, then re-install the blade guard/spreader or riving knife and standard table insert.

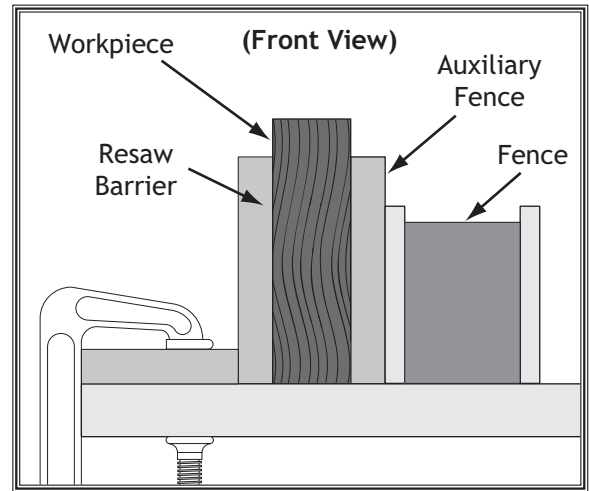

Figure 68. Ideal resaw workpiece setup.

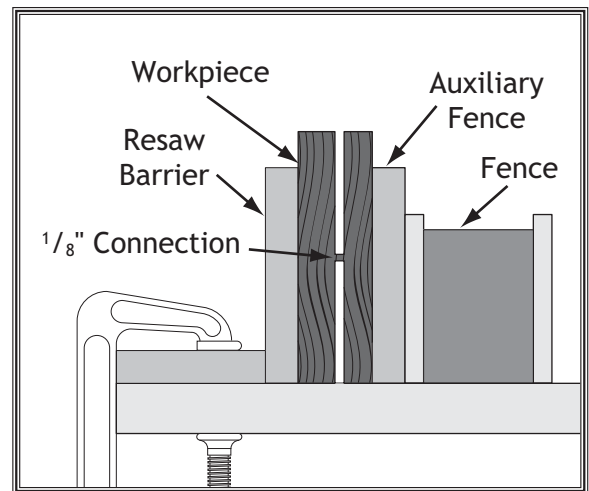

Figure 69. Ideal completed resaw cut.

WARNING

The danger of kickback increases relative to the depth of a cut. Reduce the risk of kickback by making multiple passes to achieve the desired depth of cut. Failure to follow these warnings could result in serious personal injury.

CAUTION

Always use push sticks or push paddles to increase safety and control during operations which require that the blade guard and spreader must be removed from the saw. ALWAYS replace the blade guard after resawing is complete.

Table Saw Accessories

The following table saw accessories may be available through your local Woodstock International Inc. Dealer. If you do not have a dealer in your area, these products are also available through online dealers. Please call or e-mail Woodstock International Inc. Customer Service to get a current listing of dealers at: 1-800-840-8420 or at sales@woodstockint.com.

The **Model D3246 Shop Fox Tenoning Jig** can help you produce perfect tenons for mortise and tenon joinery. This tenoning jig also adjusts for angled tenon cutting set-ups. Standard $\frac{3}{8}$ " x $\frac{3}{4}$ " miter bar fits all miter gauge slots including T-slots.

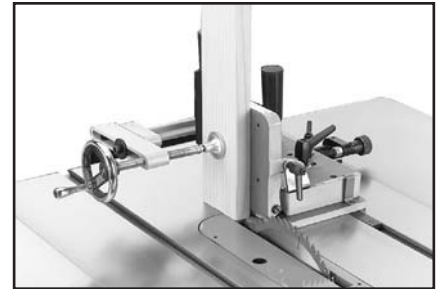

The **Model W1500 Shop Fox Right Angle Jig** is constructed using top quality aluminum castings and plates which are machined to exacting tolerances. It has the perfect weight-use ratio to dampen vibration, yet is still light enough to easily slide the workpiece through the machining process. Its quality and precision are evident from the first cut. Cut tenons, dados, rail ends, and finger joints safely and with complete accuracy.



The **Model D3096 Shop Fox Featherboard** can reduce the risk of kick-back and help you achieve consistent results. Designed to lock into standard $\frac{3}{8}$ " x $\frac{3}{4}$ " miter gauge slots, these featherboards are adjustable for various stock widths and miter slot locations. No drilling or bulky clamp arrangements.



The **Model D3122 Shop Fox Push Stick** can help you keep your hands a safe distance from blades and cutters while still maintaining control of the workpiece against machine fences. A true necessity when running narrow stock. Durable handle is designed for maximum control. Measure $13\frac{1}{2}$ " overall.



The **Model W1727 Shop Fox 1 HP Dust Collector** is the perfect companion for the Model W1819/W1820. It packs a 1 HP, 110V/220V, single-phase motor and 800 CFM air suction capacity.



Power Feeders will make light work out of those big jobs with greater accuracy and safety. The **Model W1765** features a 1/4 HP, 110V, 1.8 Amp motor. The **Model W1766** features a 1/2 HP, 220V, 4 Amp motor. Both models feature forward/reverse, XYZ adjustment, multiple feed speeds, and synthetic rubber wheels.

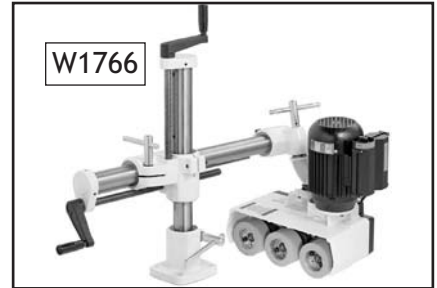

The **Model D3207 Magnetic Base with Dial Indicator in Case** is the best value in precision measuring instruments. Powerful magnetic base with infinitely adjustable control arm, fine tuning beam and magnetic switch. Add to this the 1" travel dial indicator with divisions of 0.001", 0.100" per revolution, and a 0.100" counter and any setup job is a snap.

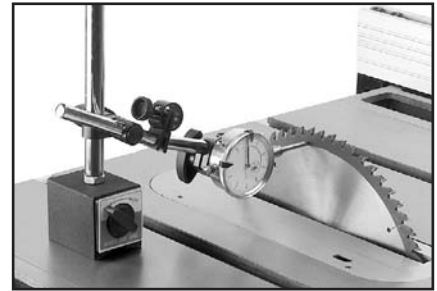

Bald Eagle Digital Calipers are very nice digital calipers with the following features: Extra large LCD readout. Accuracy: ± 0.001"/ 0.02mm. Resolution: 0.0005/ 0.01mm. Inch and metric digital display. Stainless steel construction. Built-in computer interface port with automatic shutoff.

- BE1031: 4" Digital Caliper
- BE1032: 6" Digital Caliper
- BE1033: 8" Digital Caliper

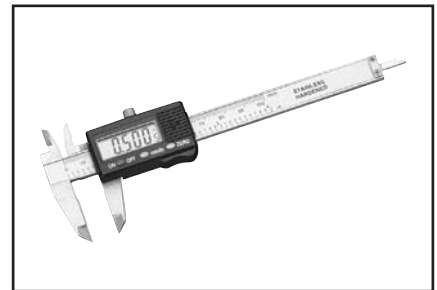

- D3383: 4" Precision Square
- D3384: 6" Precision Square



High precision **Aluminum Squares** are perfect for square layouts and machine setup.

- D3068: 10" Aluminum Square
- D3069: 12" Aluminum Square
- D3070: 18" Aluminum Square
- D3071: 24" Aluminum Square



SHOP-MADE SAFETY ACCESSORIES

Featherboards

Easily made from scrap stock, featherboards (Figure 70) provide an added degree of protection against kickback, especially when used together with push sticks. They also maintain pressure on the workpiece to keep it against the fence or table while cutting, which makes the operation easier and safer because the cut can be completed without the operator's hands getting near the blade. The angled ends and flexibility of the fingers allow the workpiece to move in only one direction, which helps slow/stop the workpiece if a kickback occurs.

Making a Featherboard

This sub-section covers the two basic types of featherboards: 1) Those secured by clamps to the table or fence, or 2) those secured by a wood runner that mounts in the table saw miter slot.

Materials for Clamp-Mounted Featherboard

Hardwood $\frac{3}{4}$ " x 3"-6" x 10"-28"1

Materials for Miter Slot-Mounted Featherboard

Hardwood $\frac{3}{4}$ " x 3"-6" x 10"-28"1

Hardwood $\frac{3}{8}$ " x (Miter Slot Width) x 5"L1

Wing Nut $\frac{1}{4}$ "-20.....1

Flat Head Screw $\frac{1}{4}$ "-20 x 2"1

Flat Washer $\frac{1}{4}$ "-201

To make a featherboard, do these steps:

1. Cut a hardwood board $\frac{3}{4}$ " thick to size. The length and width of the board can vary according to your design. Most featherboards are 10"-28" long and 3"-6" wide. Make sure the wood grain runs parallel with the length of the featherboard, so the fingers you create in Step 3 will bend without breaking.
2. Cut a 30° angle at one end of the board.

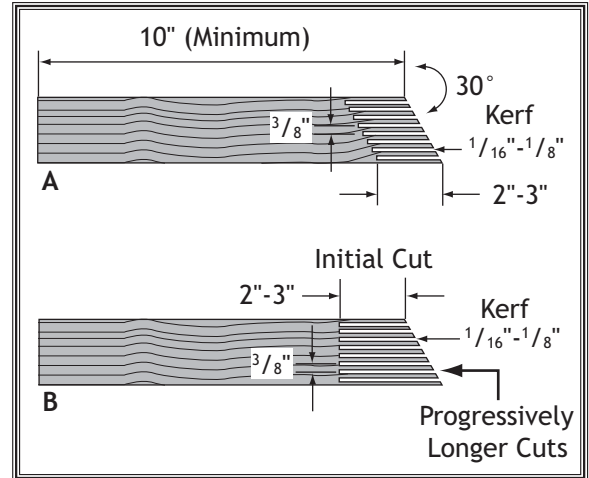

Figure 70. Patterns for featherboards (top view shown).

CAUTION

We recommend using a bandsaw for making fingers because it tends to be safer. A table saw can be used, but it will over-cut the underside of the ends, produce a thicker kerf, and require you to stop the blade half-way through the cut, which can be dangerous.

NOTICE

Only steps 1-3 are required to make a clamp-mounted featherboard.

3. Make a series of end cuts with the grain, approximately $\frac{3}{8}$ "- $\frac{1}{4}$ " apart and 2"-3" long, as shown in **Figure 70 (A)**.

Alternatively, start cuts at 2"-3" deep, then make them progressively deeper, as shown in **Figure 70 (B)**.

IMPORTANT: Cuts made across the grain will result in weak fingers that easily break when flexed. When made correctly, the fingers should withstand flexing from moderate pressure. To test the finger flexibility, push firmly on the ends with your thumb. If the fingers do not flex, they are likely too thick (the cuts are too far apart).

4. Rout a $\frac{1}{4}$ "- $\frac{3}{8}$ " wide slot 4"-5" long in the workpiece and 1"-2" from the short end of the featherboard (see **Figure 71**).

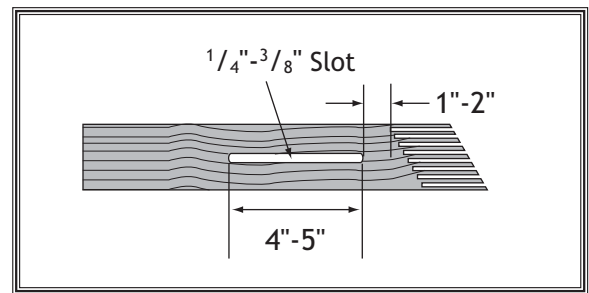

Figure 71. Slot routed in featherboard.

5. Cut a miter bar that will fit in the table miter slot approximately 5" long, as shown in **Figure 72**.

Tip: Consider making the miter bar longer for larger featherboards—approximately half the length of the total featherboard—to support the force applied to the featherboard during use.

6. Drill a $\frac{1}{4}$ " hole in the center of the bar, then countersink the bottom to fit a $\frac{1}{4}$ "-20 flat head screw.
7. Mark a 4" line through the center of the countersunk hole, then use a jig saw with a narrow blade to cut it out.
8. Assemble the miter bar and featherboard with a $\frac{1}{4}$ "-20 x flat head screw, flat washer, and a wing nut (see **Figure 73**). Congratulations! Your featherboard is complete.

Tip: The length of the flat head screw depends on the thickness of the featherboard—though $1\frac{1}{2}$ " to 2" lengths usually work.

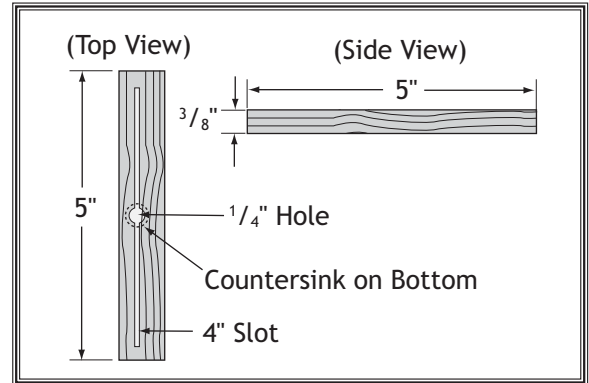

Figure 72. Miter bar pattern.

Now, proceed to **Mounting Featherboard in Miter Slot** on **Page 57**.

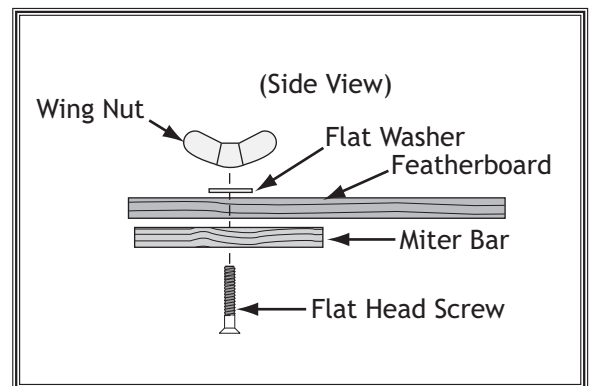

Figure 73. Assembling miter slot featherboard components.

Mounting Featherboards with Clamps

1. Lower the saw blade, then adjust the fence to the desired width and secure it.
2. Place the workpiece against the fence, making sure it is 1" in front of the blade.
3. Place a featherboard on the table away from the blade so all fingers point forward and contact the workpiece (see **Figure 74**).
4. Secure the featherboard to the table with a clamp.
5. Check the featherboard by pushing it with your thumb to ensure it is secure.
 - If the featherboard moves, tighten the clamp more.
6. Mount a second featherboard to the fence with another clamp (see **Figure 74**), then repeat **Step 5** to ensure it is secure.

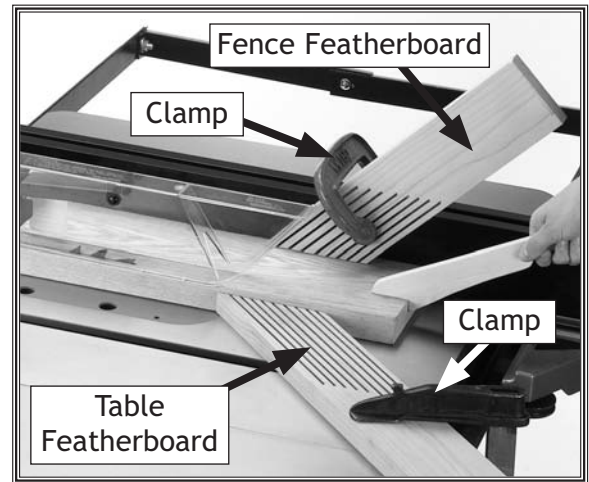

Figure 74. Example of featherboards secured with clamps.

Mounting Featherboard in Miter Slot

1. Lower the saw blade, then adjust the fence to the desired width and secure it.
2. Place the workpiece evenly against the fence, with the end approximately 1" in front of the blade.
3. Slide the featherboard miter bar into the miter slot, making sure the fingers slant toward the blade, as shown in **Figure 75**.
4. Position the fingered edge of the featherboard against the edge of the workpiece, so that all of the fingers contact the workpiece. Slide the featherboard toward the blade until the first finger is nearly even with the end of the workpiece, which should be approximately 1" away from the blade.
5. Double check the workpiece and the featherboard to ensure they are properly positioned as described in **Step 4**. Then secure the featherboard to the table. Check the featherboard by hand to make sure it is tight.

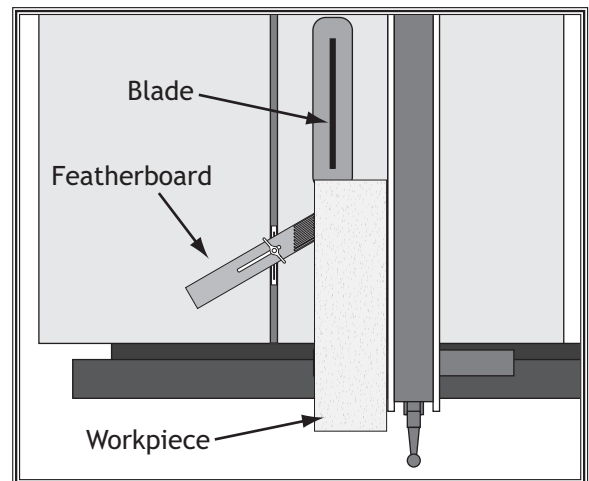

Figure 75. Featherboard installed in miter slot and supporting workpiece for ripping cut.

Note: *The featherboard should be placed firmly enough against the workpiece to keep it against the fence but not so tight that it is difficult to feed the workpiece.*

Push Sticks

When used correctly, push sticks reduce the risk of injury by keeping hands away from the blade while cutting. In the event of an accident, a push stick can absorb damage that would have otherwise happened to hands or fingers. Use push sticks whenever your hands will get within 12" of the blade. To maintain control when cutting large workpieces, start the cut by feeding with your hands then use push sticks to finish the cut, so your hands are not on the end of the workpiece as it passes through the blade.

Feeding: Place the notched end of the push stick against the end of the workpiece (see inset Figure 76), and move the workpiece into the blade with steady downward and forward pressure.

Supporting: A second push stick can be used to keep the workpiece firmly against the fence while cutting. When using a push stick in this manner, only apply pressure before the blade; otherwise, pushing the workpiece against or behind the blade will increase the risk of kickback (see Figure 76).

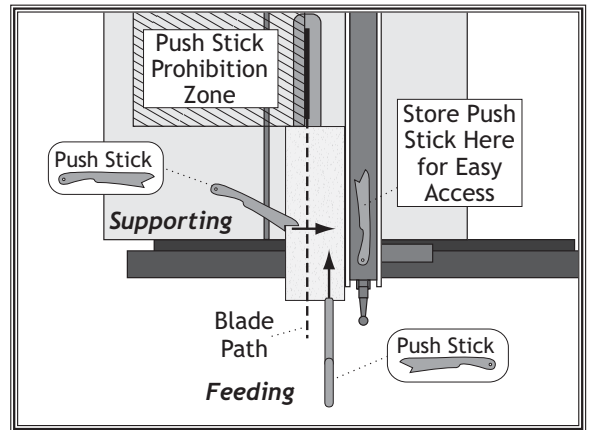

Figure 76. Using push sticks to rip narrow stock.

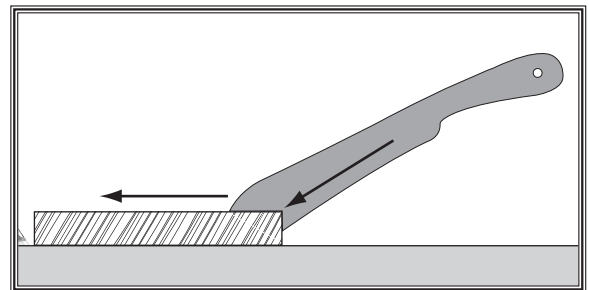

Figure 77. Side view of push stick in-use.

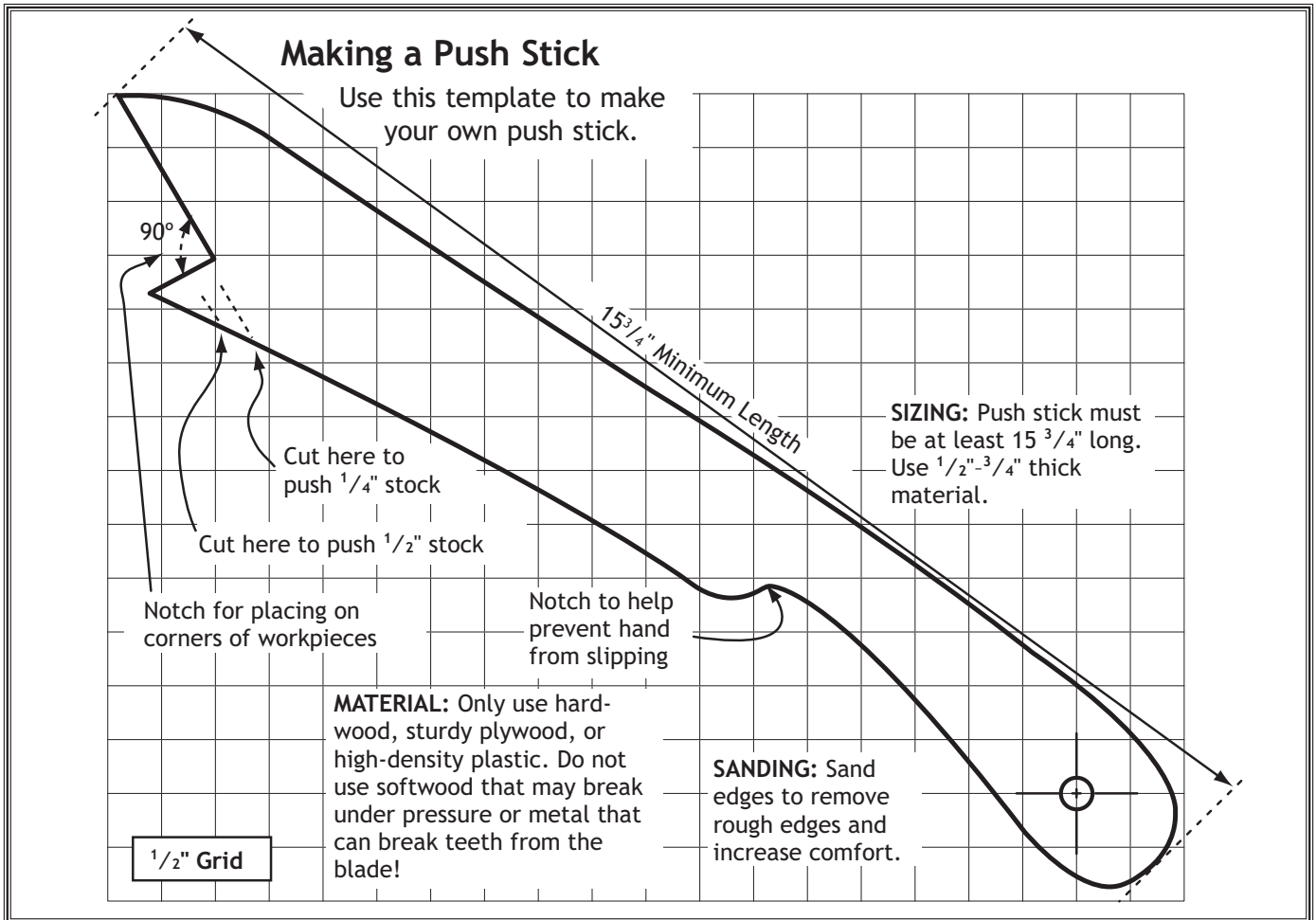

Figure 78. Template for a basic shop-made push stick (not shown at actual size).

Push Blocks

When used correctly, a push block reduces the risk of injury by keeping hands away from the blade while cutting. In the event of an accident, a push block often takes the damage that would have otherwise happened to hands or fingers.

A push block can be used in place of or in addition to a push stick for feeding workpieces into the blade. Due to their design, push blocks allow the operator to apply firm downward pressure on the workpiece that could not otherwise be achieved with a push stick.

The push block design on this page (see **Figure 81**) can be used in two different ways (see **Figure 80**). Typically, the bottom of the push block is used until the end of the workpiece reaches the blade.

The notched end of the push block is then used to push the workpiece the rest of the way through the cut, keeping the operator's hands at a safe distance from the blade. A push stick is often used at the same time in the other hand to support the workpiece during the cut.

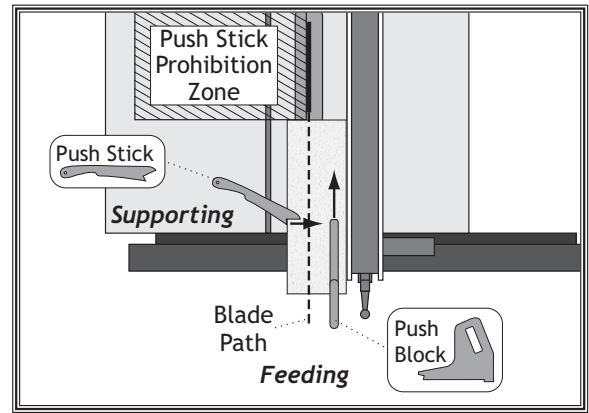

Figure 79. Using a push block and push stick to make a rip cut.

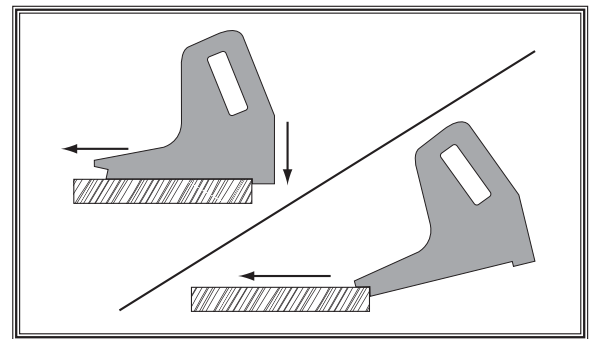

Figure 80. Side view of push block in use.

Making a Push Block

Use this template to make your own push block.

Notch for use as a push stick

Handle for firm grip

CAUTION: Only use hardwood, sturdy plywood, or high-density plastic. Do not use softwood that may break under pressure or metal that can break teeth from the blade!

1/2" Grid

CAUTION: Bottom of handle must be at least 4" above bottom of push block to keep hand away from blade.

Make push block with 1/2"-3/4" thick material

4"

1/4"-1/2"

Lip for pushing workpiece

9"-10" Minimum Length

Figure 81. Template for a basic shop-made push stick (not shown at actual size).

Narrow-Rip Auxiliary Fence & Push Block

There are designs for hundreds of specialty jigs that can be found in books, trade magazines, and the internet. These types of jigs can greatly improve the safety and consistency of cuts. They are particularly useful during production runs when dozens or hundreds of the same type of cut need to be made.

The narrow-rip auxiliary fence and push block system shown in this section is an example of a specialty jig that can be made to increase the safety of very narrow rip cuts.

Making a Narrow-Rip Push Block for an Auxiliary Fence

Materials for Narrow-Rip Push Block & Auxiliary Fence

Hardwood $\frac{3}{4}$ " x 3" x Length of Fence	1
Plywood $\frac{1}{2}$ " x $5\frac{1}{4}$ " x Length of Fence	1
Plywood $\frac{1}{2}$ " x 10" x 5"-9"	1
Plywood $\frac{1}{2}$ " x 15" x $5\frac{3}{8}$ "	1
Wood Screws #8 x $1\frac{1}{4}$ "	As Needed

To make a narrow-rip push block, do these steps:

1. Cut a piece of $\frac{1}{2}$ " thick plywood $5\frac{1}{4}$ " wide and as long as your table saw fence; cut a piece of $\frac{3}{4}$ " thick hardwood 3" wide and as long as your table saw fence, as shown in **Figure 82**.
- Note:** We recommend cutting the hardwood board oversize, then jointing and planing it to the correct size to make sure the board is square and flat. Only use furniture-grade plywood or kiln-dried hardwood to prevent warping.
2. Pre-drill and countersink eight pilot holes $\frac{3}{8}$ " from the bottom of the 3" wide board, as shown in **Figure 83**, then fasten the $5\frac{1}{4}$ " and 3" wide boards with eight #8 x $1\frac{1}{4}$ " wood screws.
 4. Using the $\frac{1}{2}$ " material you used in the previous steps, cut out pieces for the push block per the dimensions shown in **Figure 84**; for the handle, cut a piece 10" long by 5"-9" high and shape it as desired to fit in your hand.
 5. Attach the handle to the base with #8 x $1\frac{1}{4}$ " wood screws, attach the lip to the base with cyanoacrylate type wood glue.

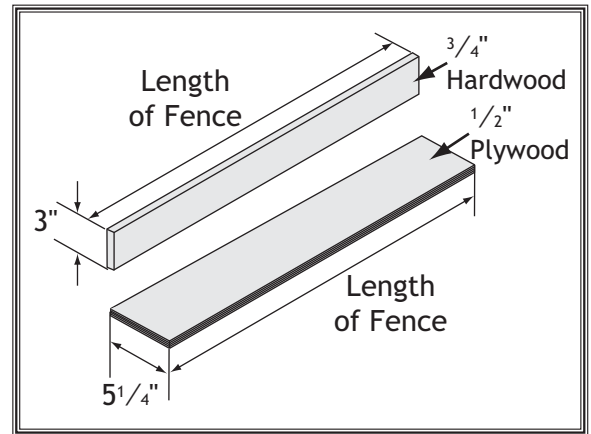

Figure 82. Auxiliary fence dimensions.

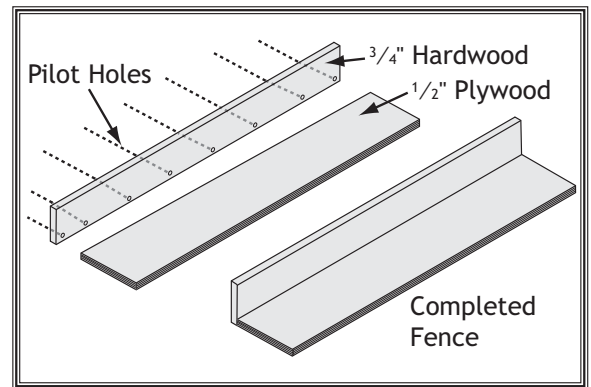

Figure 83. Location of pilot holes.

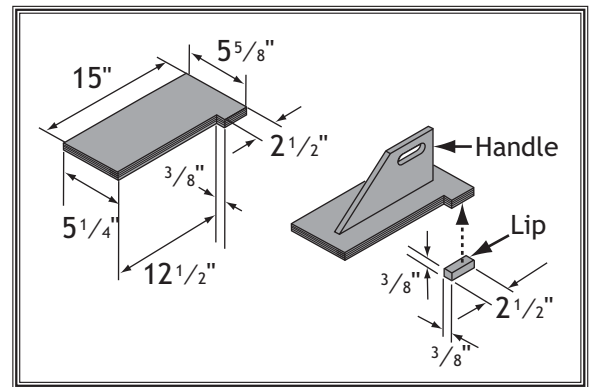

Figure 84. Push block dimensions and construction.

Using the Auxiliary Fence and Push Block

1. Place the auxiliary fence on the table and clamp it to the fence at both ends, then adjust the distance between the auxiliary fence and the blade—this determines how wide the workpiece will be ripped (see **Figure 85**).
2. Install the blade guard, then secure the spreader pawls in the upright position, as shown in **Figure 48** on **Page 37**, so they do not interfere with the push block lip.
3. Place the workpiece 1" in front of the blade and evenly against the table and the auxiliary fence.
4. Turn the saw *ON*, then begin ripping the workpiece using a push stick for side support.

As the workpiece nears the end of the cut, place the push block on the auxiliary fence with the lip directly behind the workpiece, then release the push stick just before it is even with the blade (see **Figure 87**). Guide the workpiece the rest of the way through the cut with the push block, then re-install the pawls on the spreader when cutting operations are finished.

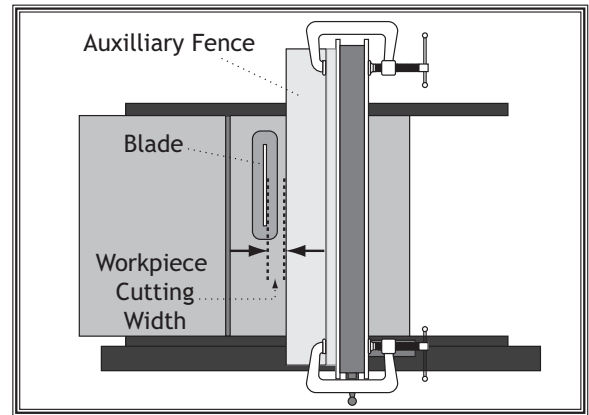

Figure 85. Adjusting ripping distance between blade and auxiliary fence.

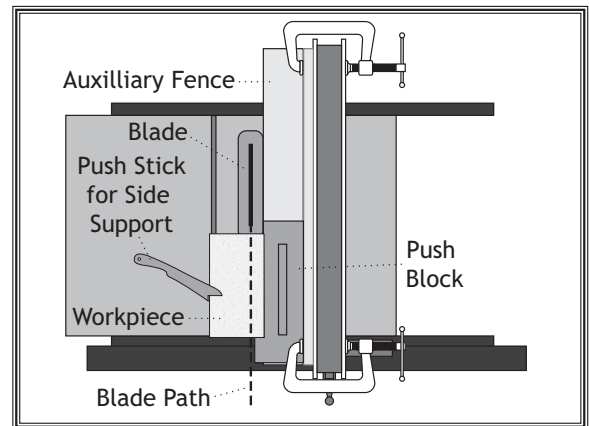

Figure 86. Adjusting ripping distance between blade and auxiliary fence.

WARNING

Keep the blade guard installed and in the down position. Failure to do this could result in serious personal injury or death.

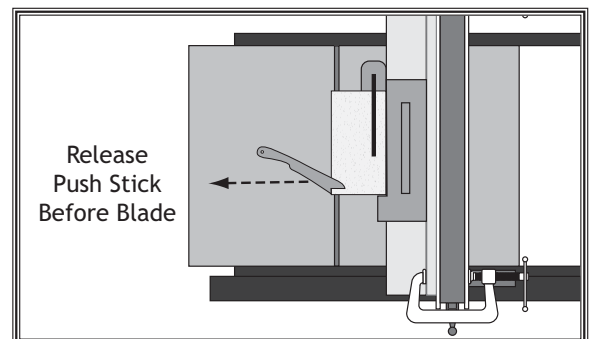

Figure 87. Ripping with push block.

Outfeed & Support Tables

One of the best accessories for improving the safety and ease of using a table saw is simply placing a large table (outfeed table) behind the saw to catch the workpiece (see **Figure 88**). Additionally, another table to the left of the saw (support table) can also help support large workpieces so they can be cut safely and accurately.



Figure 88. Example of outfeed & support tables.

Crosscut Sled

A crosscut sled (see **Figure 89**) is a fantastic way to improve the safety and accuracy of crosscutting on the table saw. Most expert table operator uses a crosscut sled when they have to crosscut a large volume of work, because the sled offers substantial protection against kickback when crosscutting.



Figure 89. Example of crosscut sled.

MAINTENANCE

Schedule

For optimum performance from your machine, follow this maintenance schedule and refer to any specific instructions given in this section.

Daily Check:

- Inspect blades for damage or wear.
- Check for loose mounting bolts/arbor nut.
- Check cords, plugs, and switch for damage.
- Check for any other condition that could hamper the safe operation of this machine.
- Wipe the table clean after every use—this ensures moisture from wood dust does not remain on bare metal surfaces.

Weekly Maintenance:

- Wipe down the table surface and grooves with a lubricant and rust preventive such as SLIPIT®.
- Vacuum dust buildup from the motor housing and trunnions.
- Clean the pitch and resin from the saw blade with a cleaner like OxiSolv® Blade & Bit Cleaner.

Monthly Maintenance:

- Check/tighten the belt tension (**Page 74**).

Cleaning

Cleaning the Model W1819/W1820 is relatively easy. Vacuum excess wood chips and sawdust, and wipe off the remaining dust with a dry cloth. If any resin has built up, use a resin dissolving cleaner to remove it.

After cleaning, treat all unpainted cast iron and steel with a non-staining lubricant.

Occasionally it will become necessary to clean the internal parts with more than a vacuum. To do this, remove the table top and clean the internal parts with resin/pitch dissolver or mineral spirits and a stiff wire brush or steel wool. **DO NOT USE WATER—WATER WILL CAUSE CAST IRON TO RUST.**

Make sure the internal workings are dry before using the saw again, so that wood dust will not accumulate. If any essential lubrication is removed during cleaning, re-lubricate those areas.

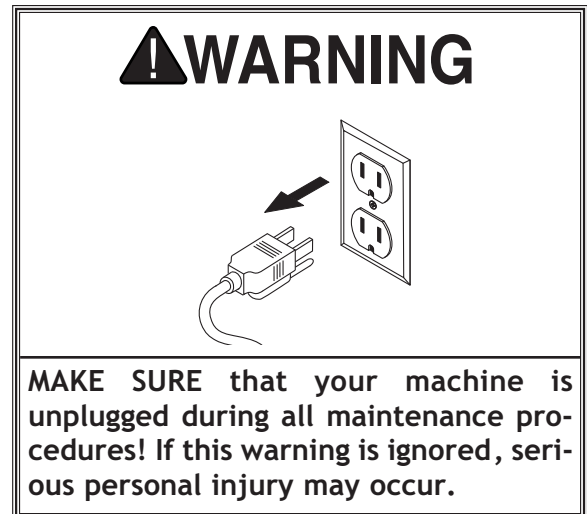

Lubrication

An essential step for lubrication is cleaning the components before lubricating them.

This step is critical because dust and chips build up on lubricated components, which makes them hard to move. Simply adding more grease to built-up grime will not result in smooth moving components.

Clean the components in this section with an oil/grease solvent cleaner.

The following are the main components that need to be lubricated:

- Trunnion Slides and Orientation Gears
- Worm Gears, Trunnion and Bearing Housing Teeth

Trunnion Slides & Orientation Gears

Clean the trunnion slides with mineral spirits and a rag, and brush a dab of lithium grease into each groove. Move the blade tilt back and forth to spread the grease (see **Figure 90**).

Also use a wire brush and mineral spirits to clean any debris or grime off the orientation gears, then apply lithium grease to the gears with a brush.

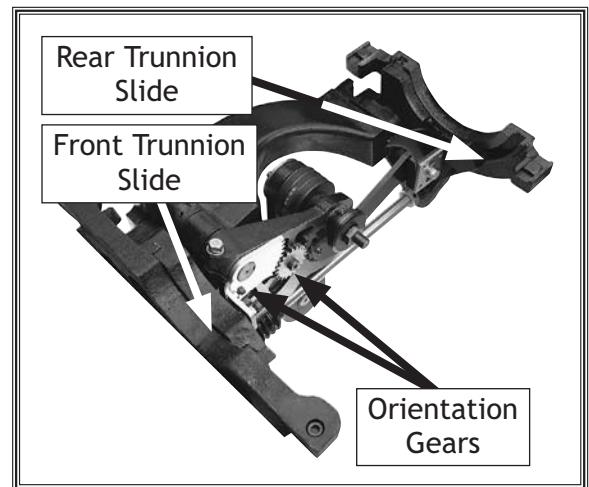

Figure 90. Trunnion slides and tilt leadscrew.

Worm Gears, Trunnion and Bearing Housing Teeth

Clean away any built up grime and debris with a wire brush and mineral spirits from the worm gears and the teeth (see **Figure 91**) on the bearing housing and trunnion. Then use a brush or rag to apply a thin coat of white lithium grease to the gears and teeth.

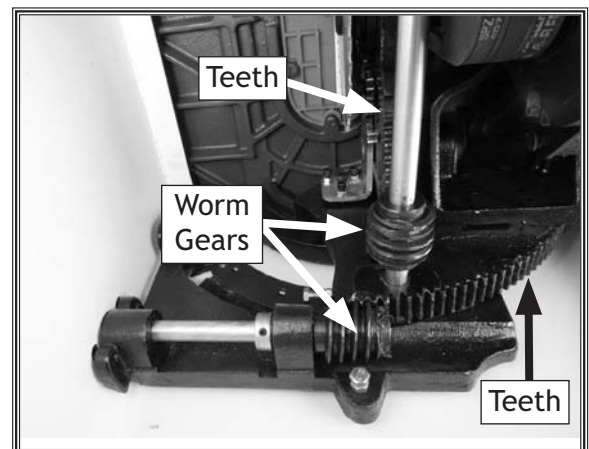

Figure 91. Worm gears and teeth.

SERVICE

General

This section covers the most common service adjustments or procedures that may need to be made during the life of your machine.

If you require additional machine service not included in this section, please contact Woodstock International Technical Support at (360) 734-3482 or send e-mail to: tech-support@shopfox.biz.

Blade Tilt Stops

The table saw features stop bolts that stop the blade exactly at 45° and 90° when tilting it with the handwheel. The tilt scale reads "0" when the blade is 90° to the table. The stops have been set at the factory and should require no adjustments, unless you notice that your cuts are not accurate.

Tools Needed	Qty
90° Square	1
45° Square	1
Hex Wrench 3mm	1
Wrench 10mm	1
Wrench 13mm	1

Setting 90° Stop Bolt

1. DISCONNECT THE SAW FROM POWER!
2. Raise the blade as high as it will go, then tilt it toward 0° until it stops and cannot be tilted any more.
3. Place a 90° square against the table and blade so it contacts the blade evenly from bottom to top, as shown in **Figure 92**. Make sure a blade tooth does not obstruct the placement of the square.
 - If the blade is 90° to the table, then adjustments do not need to be made. Make sure the tilt indicator arrow shown in **Figure 93** points to the 0° mark on the scale. Adjust the position by loosening the button head screw, moving the indicator with your fingers, then tightening the screw.
 - If the blade is not 90° to the table, you will need to adjust the 90° stop screw. Proceed to the next step.

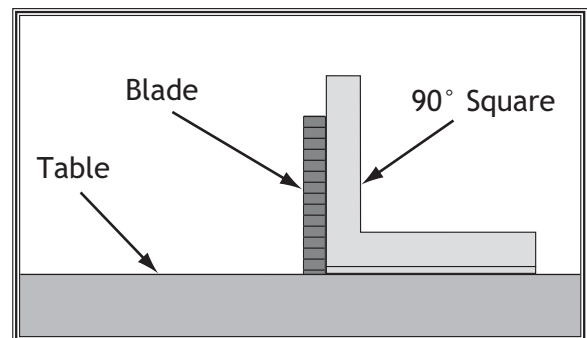
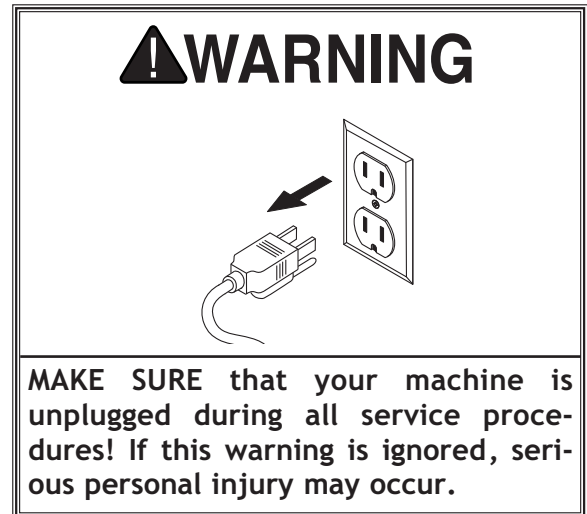

Figure 92. Checking blade at 90°.

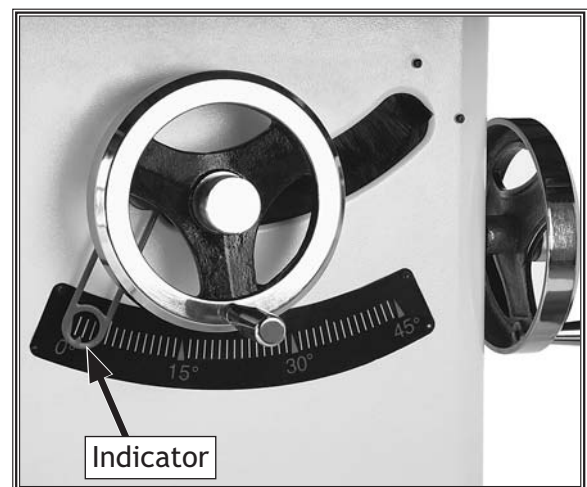

Figure 93. Tilt indicator arrow.

4. Tilt the blade away from 0° by about 5°, so there is room for the stop bolt to move.
5. Open the motor access cover, loosen the jam nut shown in **Figures 94-95**, adjust the stop bolt up or down according to how far off the blade was from 90°. Repeat **Step 3** and, if necessary, make additional adjustments to the stop bolt until the table stops at 90°.
6. Tighten the jam nut, then close the motor cover.

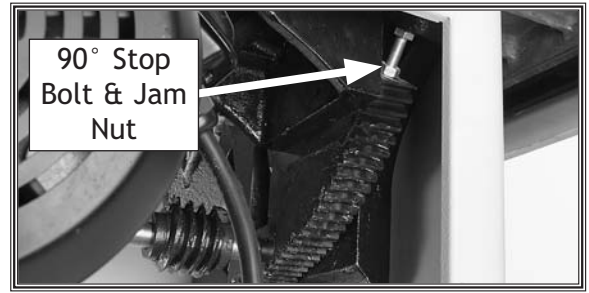

Figure 94. 90° stop bolt and jam nut.

Setting 45° Stop Bolt

1. DISCONNECT THE SAW FROM POWER!
2. Raise the blade as high as it will go, then tilt it towards 45° until it stops and cannot be tilted any more.
3. Place a 45° square against the table and blade so it contacts the blade evenly from bottom to top, as shown in **Figure 96**. Make sure a blade tooth does not obstruct the placement of the square.
 - If the blade is 45° to the table, then adjustments do not need to be made.
 - If the blade is not 45° to the table, you will need to adjust the 45° stop screw. Proceed to the next step.

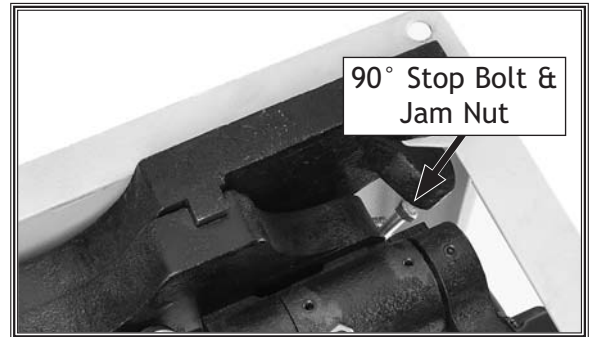

Figure 95. 90° stop bolt and jam nut (table removed for clarity).

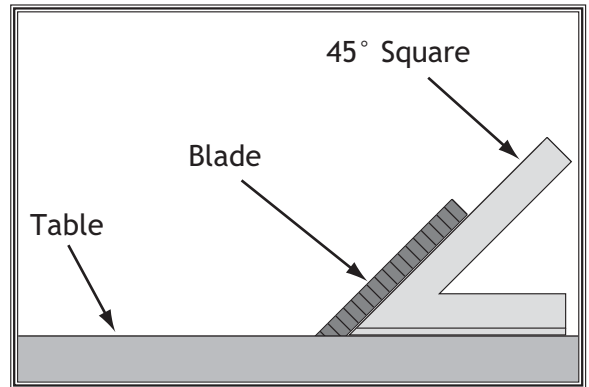

Figure 96. Checking blade at 45°.

4. Tilt the blade to 15°, so there is room for the stop bolt to move, then remove the dust port to access the stop bolt.
5. Loosen the jam nut on the 45° stop bolt (see **Figure 97**) with a 13mm wrench, adjust the stop bolt up or down according to how far off the blade was from 45°.
6. Continue adjusting the stop bolt until it contacts the cabinet when the blade is at 45°, then tighten the jam nut.
7. Close the dust port.

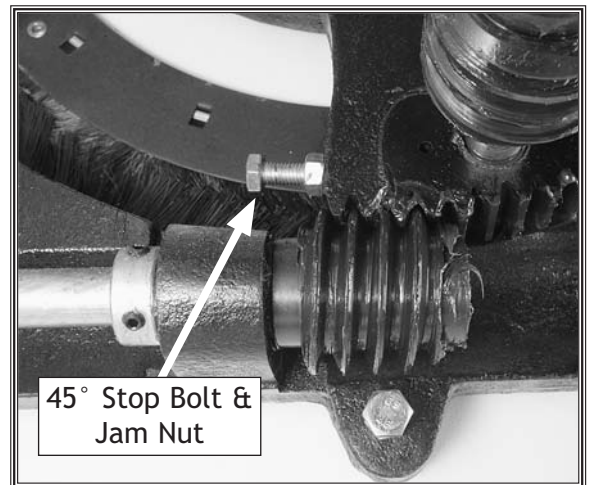

Figure 97. 45° stop bolt and jam nut.

Miter Slot to Blade Parallelism

Your table saw will give the best results if the miter slot and the rip fence are parallel to the blade. If either of these are not exactly parallel, your cuts and your finished work will be lower in quality, but more importantly, the risk of kickback will be increased. Take the time to adjust your table saw properly. A few minutes now will be time well spent.

Tools Needed	Qty
Adjustable Square	1
Marker	1

To adjust the blade parallel to the miter slot, do these steps:

1. DISCONNECT THE SAW FROM POWER!

2. Use an adjustable square to measure the distance from the miter slot to a carbide tip on the blade, as shown in **Figure 98**. Make sure that the face of the adjustable square is even along the miter slot.

3. With the end of the adjustable square just touching the tooth or carbide tip, lock the square in place. Now, mark the carbide tip with a marker where you made this measurement.

4. Rotate the marked blade tip to the other end of the table insert.

5. Slide the adjustable square down to the other end of the table insert, and compare the distance from the marked blade tip to the end of the adjustable square.
 - If the blade tip measurement is not the same, the table will need to be adjusted. Proceed to **Step 6**.
 - If the blade tip measurement is the same on both sides, go to **Step 7**.

6. To adjust the table, loosen the four cap screws in the table mounting locations (see **Figure 99**) and slightly tap the table in the needed direction. Repeat **Steps 2-5** until the blade and miter slot are parallel.

7. Tighten the table mounting cap screws in a crisscross, alternating manner.

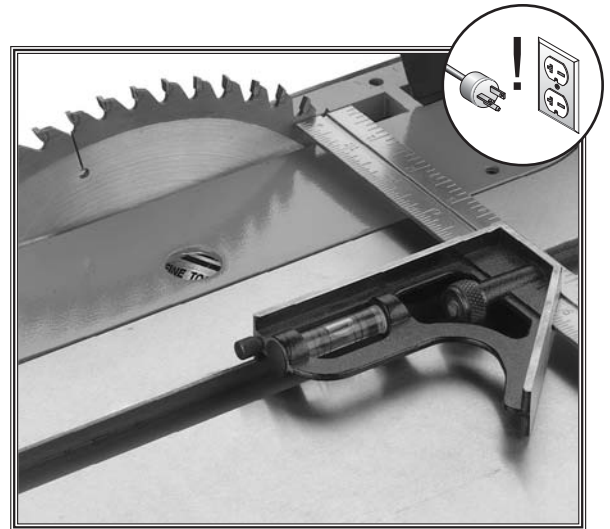

Figure 98. Example of adjusting blade to miter slot.

⚠ CAUTION

The saw blade is dangerously sharp. Use extra care or wear gloves when handling the blade or working near it.

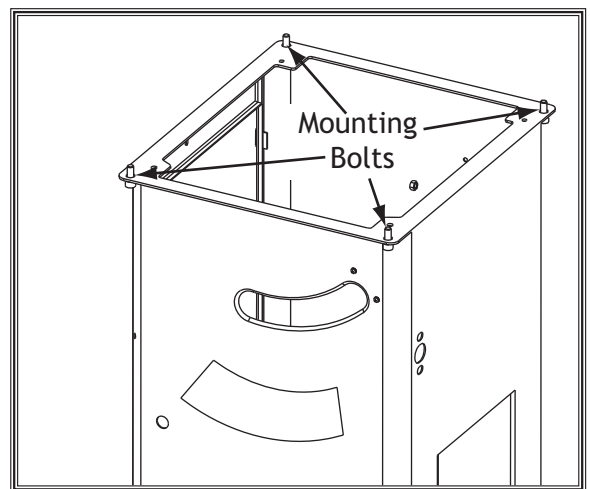

Figure 99. Table mounting bolts.

SERVICE

Spreader or Riving Knife Alignment

Checking Alignment

The blade guard spreader and riving knife must be aligned with the blade when installed. If the spreader/riving knife is not aligned with the blade, then the workpiece will be forced sideways during the cut, which will increase the risk of kickback.

Tools Needed	Qty
Straightedge	1

To check the spreader/riving knife alignment, do these steps:

1. DISCONNECT THE SAW FROM POWER!
2. Raise the saw blade to the maximum height so you have easy working access.
3. Place the straightedge alternately against the top and bottom of blade and spreader/riving knife, as shown in **Figure 100**. The spreader/riving knife should be parallel with the blade along its length at both positions, and it should be in the "Alignment Zone," as shown in **Figure 101**.
 - If the spreader/riving knife is not parallel with the blade and inside the alignment zone, then it needs to be adjusted. Proceed to **Adjusting Alignment** instructions.
 - If the spreader/riving knife is not parallel with the blade at either the top or bottom, it may be bent.
4. Remove the spreader/riving knife and place it on a flat surface and check to see if the spreader/riving knife lays evenly along its length.
 - If the spreader/riving knife does not lay evenly, proceed to **Adjusting Bent Spreader/Riving Knife** on **Page 69**.

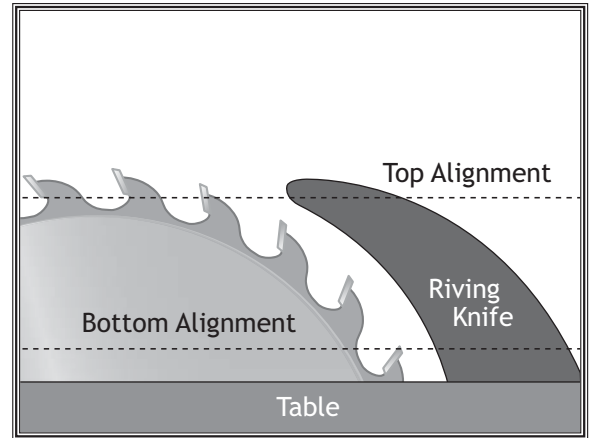

Figure 100. Checking top and bottom riving knife parallelism with blade.

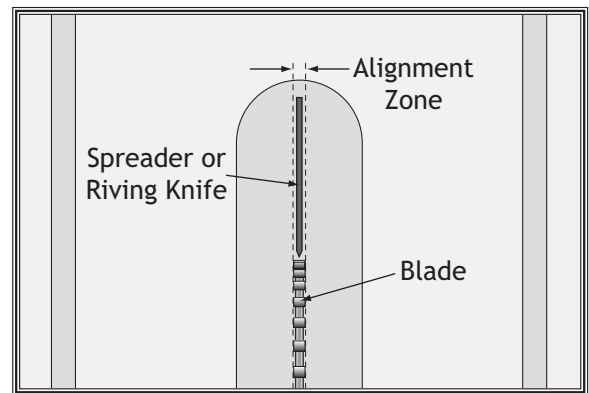

Figure 101. Spreader/riving knife alignment zone.

Adjusting Alignment

The spreader/riving knife mounting position can be adjusted into alignment with the blade using the set screws on the spreader/riving knife mounting block.

Possible Tools Needed	Qty
Hex Wrench 3mm	1
Hex Wrench 5mm	1

To adjust the spreader/riving knife position, do these steps:

1. DISCONNECT THE SAW FROM POWER!
2. Remove the table insert.
3. Adjust each pair of set screws that controls the direction required to move the mounting block so the riving knife can be aligned with the blade (see **Figure 102**). Make sure to move both screws in even increments.
4. Re-install the table insert.
5. Follow **Checking Alignment, Steps 1-3** to determine if the spreader/riving knife is parallel with the blade and inside the "Alignment Zone."
 - If the spreader/riving knife is in the alignment zone, no additional steps are necessary.
 - If the spreader/riving knife is still not in the alignment zone, continue adjusting the set screws on the mounting block as necessary to correctly position the spreader/riving knife.
6. Tighten the two cap screws on the mounting block to secure the spreader/riving knife adjustment.

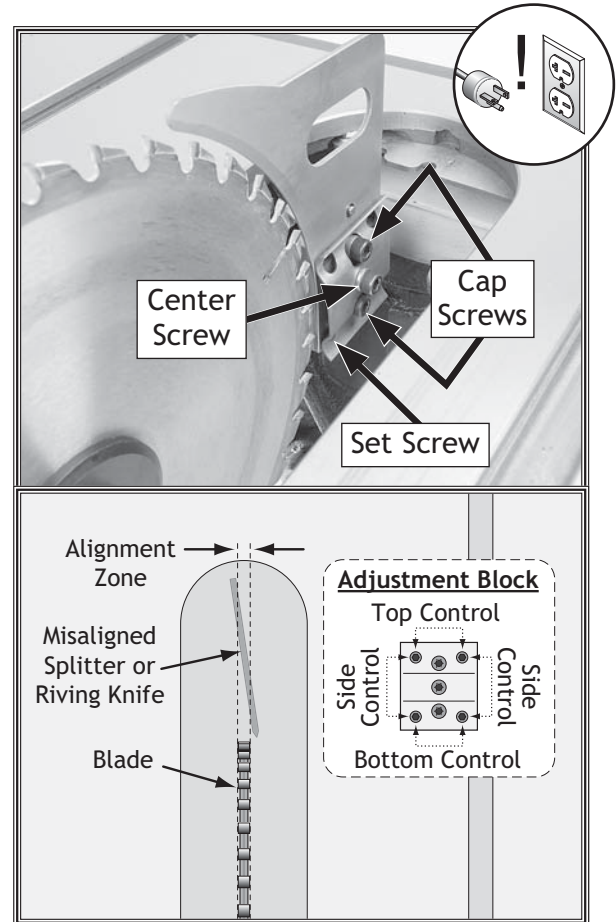

Figure 102. Set screws for adjusting spreader/riving knife position.

Adjusting Bent Spreader/Riving Knife

1. DISCONNECT THE SAW FROM POWER!
2. Bend the spreader or riving knife by hand while installed, then follow **Steps 1-3** in **Checking Alignment** to determine if it is parallel with the blade and inside the "Alignment Zone" (refer to **Checking Alignment**).
 - If this does not work, remove it to straighten.
 - If you cannot straighten it properly, replace it.

Fence Adjustments

There are four main adjustments for the fence: (1) square, (2) height, (3) parallelism, and (4) clamping pressure. Keep in mind that these adjustments are interconnected and some trial-and-error may be needed to achieve satisfactory results.

Tools Needed	Qty
Hex Wrench 6mm	1
Square	1
Felt-Tipped Marker	1

Square and Height

The fence face must be square to the table in order to produce square cuts. The fence should be adjusted so it does not drag across the table surface.

To check/adjust the fence height and squareness to the table, do these steps:

1. DISCONNECT THE SAW FROM POWER!
2. Place a square on the table against the face of the fence (see **Figure 103**) to check if the fence is square to the table.
 - If the fence is square to table, go to **Step 4**.
 - If the fence is not square to table, go to **Step 3**.
3. Adjust the set screws (see **Figure 104**) on top of the fence bracket to ensure the fence face is 90° to the table, then tighten the knurled lock nuts.
4. Look at the gap between the fence and table top.
 - If the gap is approximately 1/16" and even from the front of the table to the back, then no additional adjustments are necessary.
 - If the gap is uneven, if the fence height is more than 1/8", or if the fence touches the table, then continue with **Step 5**.
5. Adjust the fence height with the rear rail foot until the gap between the table and the fence is approximately 1/16" and even from the front of the table to the back. **Note:** *If the front end of the fence needs to be adjusted up or down, use the set screws from **Figure 104**; turn them in even increments and recheck the squareness afterwards.*

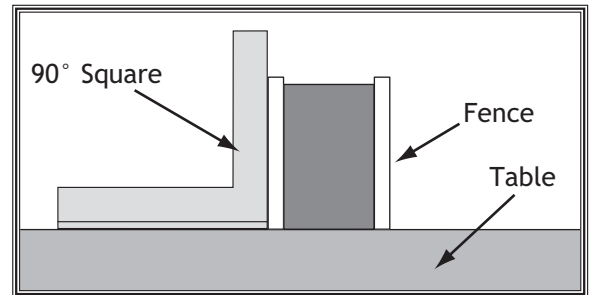

Figure 103. Checking if fence is square to table.

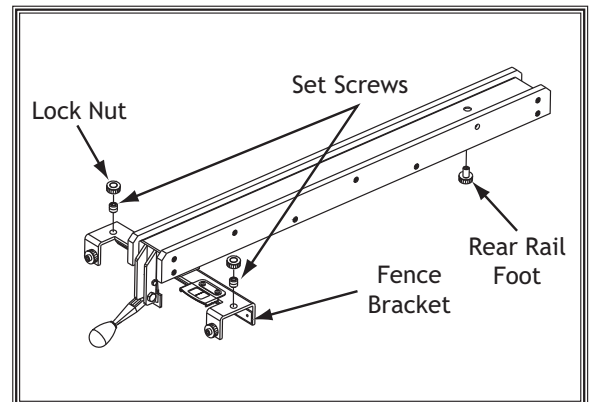

Figure 104. Fence components used to adjust fence height and squareness to table.

Clamping Pressure and Parallelism

Set screws on the rear side of the fence bracket adjust the clamping pressure to hold your fence securely, and position the fence parallel to the blade.

To adjust the fence clamping pressure and parallelism to the blade, do these steps:

1. DISCONNECT THE SAW FROM POWER!
2. Remove the fence.
3. Equally adjust the set screws shown in **Figure 105** on the rear side of the front bracket as necessary until the clamping pressure is strong enough that the fence will not move as pressure is applied against it.
4. Place the fence approximately 4" away from the blade.
5. Measure the distance between the fence and the front of the blade at one end of the table insert, then mark the tooth that you measured from with a felt-tipped marker.
6. Rotate the blade to the other end of the table insert (see **Figure 106**), and recheck the distance between the fence and the blade to ensure they are parallel.
7. Use trial-and-error to adjust the set screws so the fence is parallel to the blade and the clamping pressure is sufficient.

Optional: Some woodworkers prefer to offset the rear of the fence $\frac{1}{64}$ " from the blade, as shown in **Figure 107**, to help prevent the workpiece from binding and burning.

The argument is that this offset adjustment reduces the chance of kickback by alleviating potential binding that may occur between the backside of the blade and fence. The trade-off is slightly less accurate cuts.

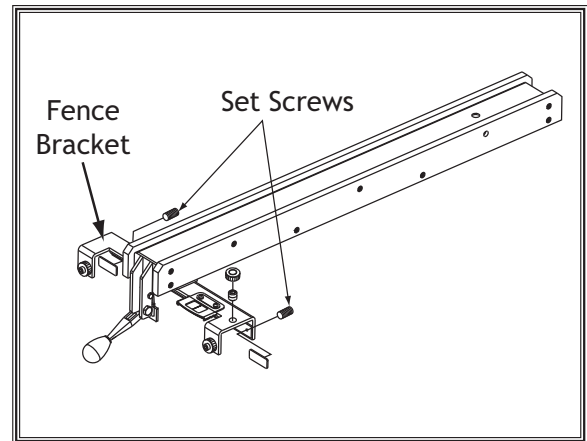

Figure 105. Location of set screws used to adjust fence parallelism and clamping pressure.

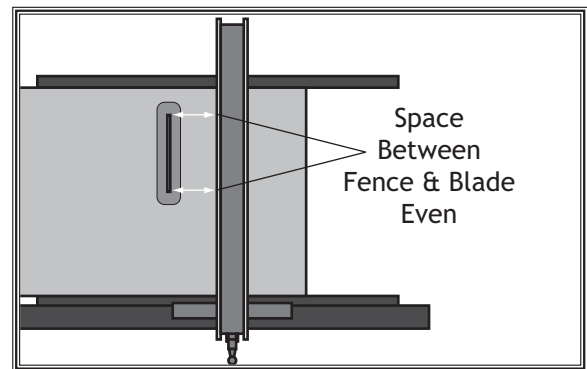

Figure 106. Example of fence aligned parallel to miter slot.

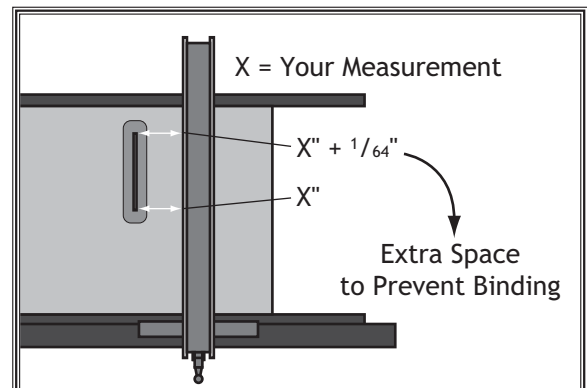

Figure 107. Adjusting fence with a $\frac{1}{64}$ " offset.

Fence Scale Calibration

The fence scale indicator window, shown in **Figure 108**, can be calibrated with the fence scale if you notice that your cuts do not accurately match what is shown on the fence scale. The indicator adjusts by loosening the two mounting screws and sliding it in the desired direction.

Tools Needed	Qty
Hex Wrench 2.5mm.....	1
Scrap Piece of Wood.....	1

To calibrate the fence scale indicator windows, do these steps:

1. Position and lock the fence at 13", as indicated by the scale, cut your scrap piece of wood.
2. Reposition and lock the fence at 12", as indicated by the scale.
3. Flip your scrap piece of wood over, placing the side that was cut in **Step 2** against the fence, and cut your scrap piece of wood.
4. Measure the width of the freshly cut workpiece with a tape measure. The workpiece width should be exactly 12". If it is not, then adjust the indicator window to match the width of the workpiece.

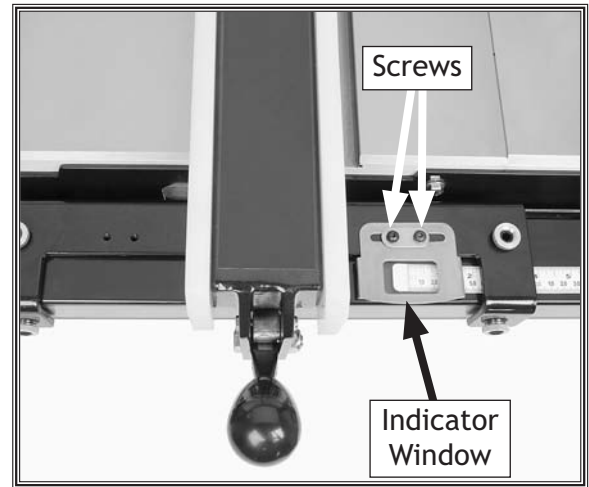

Figure 108. Fence indicator window.

Miter Gauge Adjustments

The miter gauge can be adjusted so it is perpendicular to the blade and so it is snug in the T-slot.

Tools Needed	Qty
90° Square	1
45° Square	1
Hex Wrench 2.5mm.....	1
Hex Wrench 2mm	1
Hex Wrench 3mm	1

Checking/Setting 90° Stops

1. DISCONNECT THE SAW FROM POWER!
2. Slide the miter gauge into the T-slot on the table.
3. Loosen the miter gauge lock knob, pull out the positive stop knob, then pivot the miter gauge body to 90° so the stop knob springs into position.
4. Place the 90° square evenly against the face of the miter gauge and the blade, as shown in **Figure 109**.
 - If the square touches the miter body and the body of the blade (not the teeth) evenly at the same time, then it is square to the blade and the 90° stop is set correctly. No further adjustments are necessary.
 - If the square does not touch the miter body and blade body evenly at the same time, then proceed to **Step 5**.
5. Loosen the button head cap screws on the positive stop knob block (see **Figure 110**), adjust the miter body until it is flush with the square, then tighten the screws.
6. Loosen the screw on the front of the miter bar, adjust the pointer to 0°, then tighten the screw.

Adjusting Miter Bar Tightness

The miter bar can be adjusted so it fits more tightly in the miter slot.

To adjust the miter bar tightness, loosen the cap screw on each guide block (see **Figure 111**), adjust the set screws as needed, then tighten the cap screw.

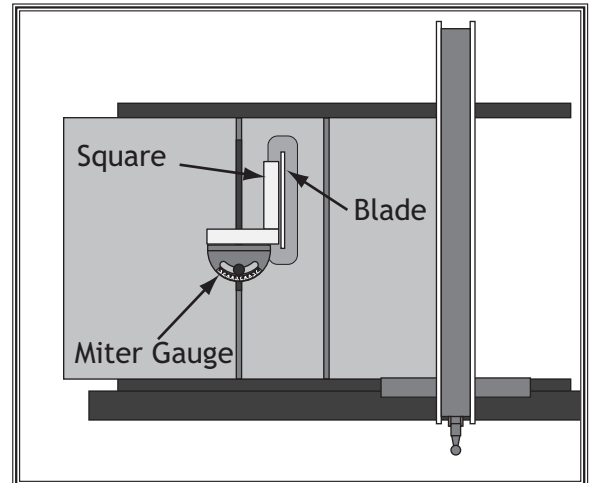

Figure 109. Checking 90° stop on miter gauge.

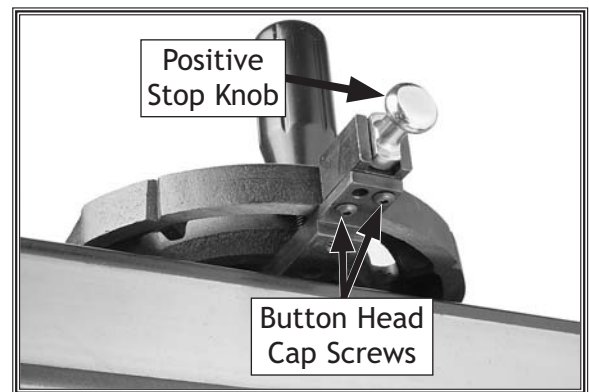

Figure 110. Screws for adjusting miter gauge body.

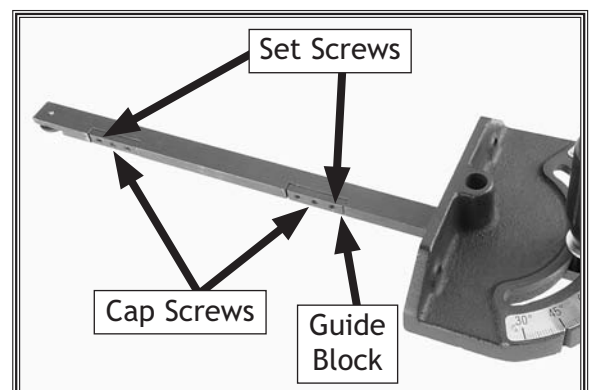

Figure 111. Screws for adjusting miter bar in miter slot.

SERVICE

Belt Tension & Replacement

The three V-belts stretch slightly as the saw is used. Most of the belt stretching will happen during the first 16 hours of use, but it may continue in small increments through continued use.

Tools Needed	Qty
Wrenches 18mm.....	2

Tensioning Belt

1. DISCONNECT THE SAW FROM POWER!
2. Lower the blade completely, then open the motor cabinet.
3. Loosen the hex nuts on the motor shown in **Figure 112**, and pivot the motor up and down to make sure that it is movable.
4. Press down on the motor with one hand to keep the belt tension tight, then tighten the hex nuts.
5. Press each V-belt in the center to check the belt tension.

The belts are correctly tensioned when there is approximately 1/2" deflection when they are pushed with moderate pressure, as shown in **Figure 113**.

- If there is more than 1/2" deflection when the V-belts are pushed with moderate pressure, loosen the hex nuts, adjust the motor downward, then tighten the hex nuts.

6. Close the motor access cover.

Replacing Belt

1. DISCONNECT THE SAW FROM POWER!
2. Lower the blade completely, then open the motor access cover.
3. Loosen the hex nuts that secure the motor (see **Figure 112**) and raise the motor fully to remove tension on the V-belts. Roll the V-belts off of the arbor and motor pulleys. Install a new matching set of V-belts onto the pulleys, lower the motor to tension the V-belts, then tighten the hex nuts.
4. Follow **Step 5** in the **Tensioning Belt** subsection to check V-belt tension, then close the motor cover.

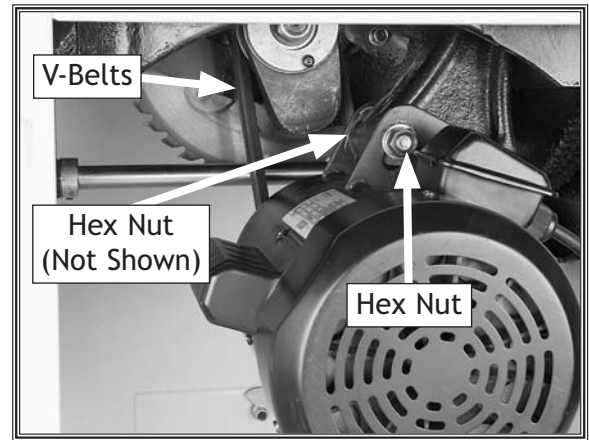

Figure 112. Motor mounting nut.

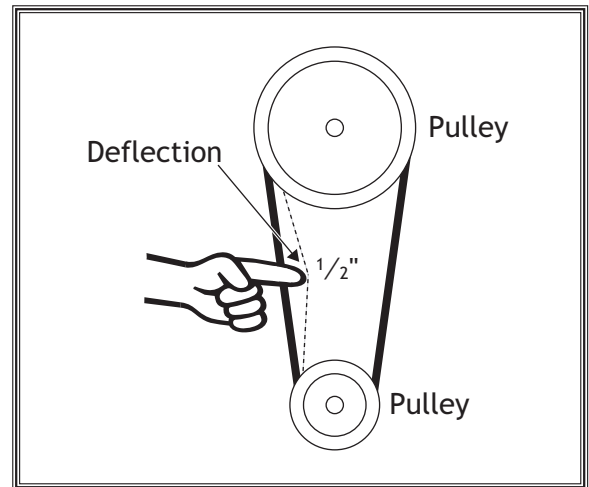

Figure 113. Checking belt tension.

Electrical Safety Instructions

These pages are current at the time of printing. However, in the spirit of improvement, we may make changes to the electrical systems of future machines. Study this diagram carefully. If you notice differences between your machine and these wiring diagrams, call Woodstock International Technical Support at (360) 734-3482.

WARNING

1. **SHOCK HAZARD.** Working on wiring that is connected to a power source is extremely dangerous. Touching electrified parts will result in personal injury including but not limited to severe burns, electrocution, or death. Disconnect the power from the machine before servicing electrical components!
2. **QUALIFIED ELECTRICIAN.** Due to the inherent hazards of electricity, only a qualified electrician should perform wiring tasks on this machine. If you are not a qualified electrician, get help from one before attempting any kind of wiring job.
3. **WIRE CONNECTIONS.** All connections must be tight to prevent wires from loosening during machine operation. Double-check all wires disconnected or connected during any wiring task to ensure tight connections.
4. **WIRE/COMPONENT DAMAGE.** Damaged wires or components increase the risk of serious personal injury, fire, or machine damage. If you notice that any wires or components are damaged while performing a wiring task, replace those wires or components before completing the task.
5. **MOTOR WIRING.** The motor wiring shown in these diagrams is current at the time of printing, but it may not match your machine. Always use the wiring diagram inside the motor junction box.
6. **MODIFICATIONS.** Using aftermarket parts or modifying the wiring beyond what is shown in the diagram may lead to unpredictable results, including serious injury or fire.
7. **CAPACITORS/INVERTERS.** Some capacitors and power inverters store an electrical charge for up to five minutes after being disconnected from the power source. To avoid being shocked, wait at least this long before working on these components.
8. **ELECTRICAL REQUIREMENTS.** You **MUST** follow the electrical requirements at the beginning of this manual when connecting your machine to a power source.
9. **EXPERIENCING DIFFICULTIES.** If you are experiencing difficulties understanding the information included in this section, contact our Technical Support at (360) 734-3482.

NOTICE

The photos and diagrams included in this section are best viewed in color. You can view these pages in color at www.shopfox.biz.

WIRING DIAGRAM COLOR KEY

BLACK	BLUE	YELLOW	LIGHT BLUE
WHITE	BROWN	YELLOW GREEN	BLUE WHITE
GREEN	GRAY	PURPLE	TURQUOISE
RED	ORANGE	PINK	

Model W1819/W1820 Wiring Diagram



Figure 114. Magnetic switch.

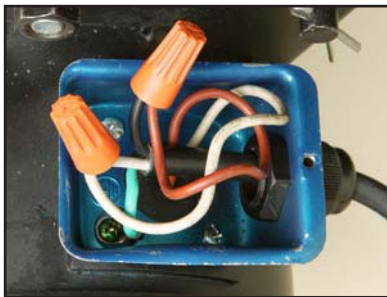
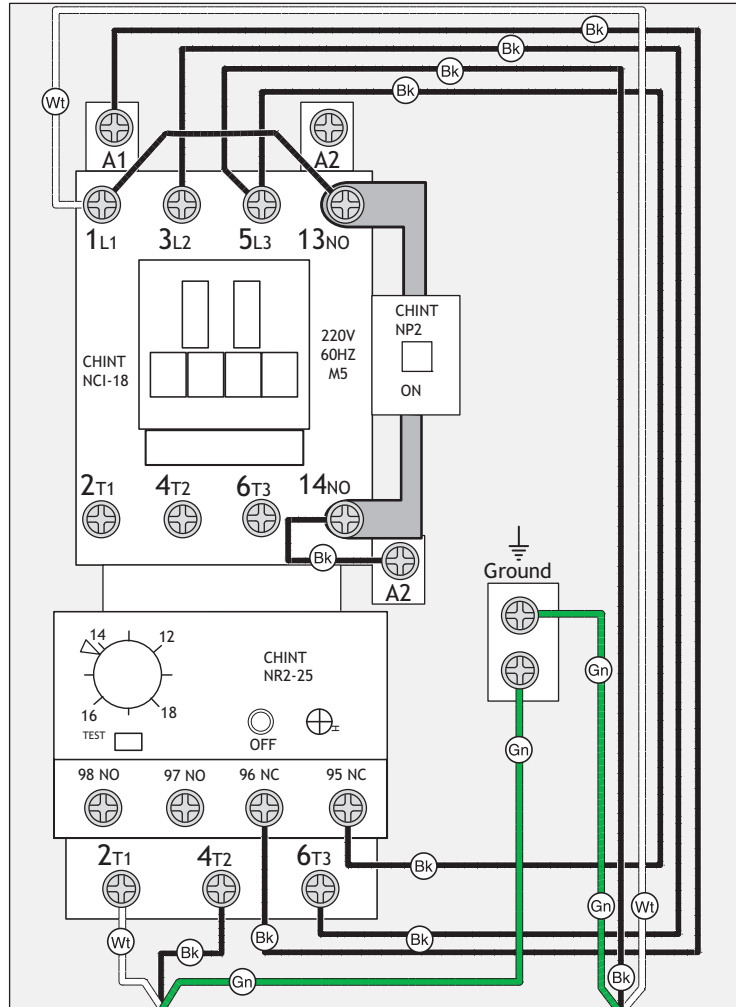
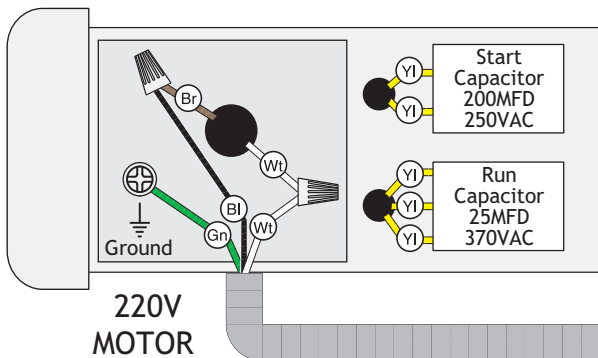

Figure 115. Motor wiring.



Figure 116. Run capacitor.



220V
MOTOR

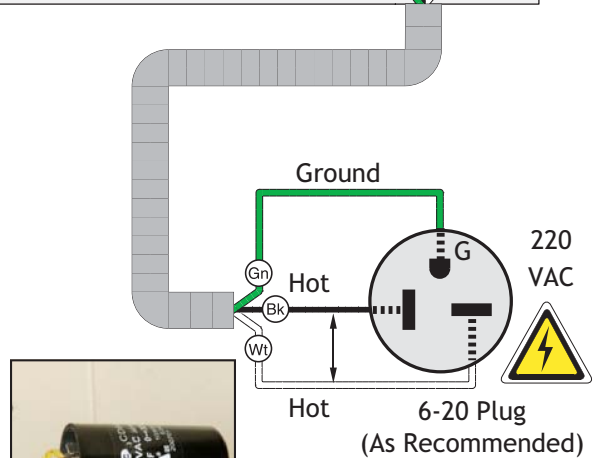
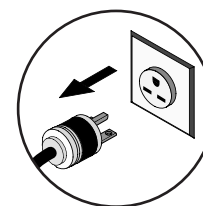

Figure 117. Start capacitor.



Troubleshooting



This section covers the most common problems and corrections with this type of machine. **WARNING! DO NOT** make any adjustments until power is disconnected and moving parts have come to a complete stop!

Symptom	Possible Cause	Possible Solution
Machine does not start or a breaker trips.	<ol style="list-style-type: none"> 1. Locking pin installed. 2. Blown fuse. 3. Power supply switched OFF or at fault. 4. Plug/receptacle at fault/wired wrong. 5. Motor connection wired wrong. 6. Wall circuit breaker tripped. 7. Wiring open/has high resistance. 8. Motor ON/OFF switch at fault. 9. Start capacitor at fault. 10. Motor at fault. 	<ol style="list-style-type: none"> 1. Remove locking pin from ON button. 2. Replace fuse/ensure no shorts. 3. Ensure power supply is on/has correct voltage. 4. Test for good contacts; correct the wiring. 5. Correct motor wiring connections. 6. Ensure circuit size is correct/replace weak breaker. 7. Check/fix broken, disconnected, or corroded wires. 8. Replace switch. 9. Test/replace if faulty. 10. Test/repair/replace.
Machine stalls or is under-powered.	<ol style="list-style-type: none"> 1. Feed rate/cutting speed too fast. 2. Workpiece material unsuitable for machine. 3. Workpiece crooked; fence mis-adjusted. 4. Machine undersized for task. 5. Run capacitor at fault. 6. Belt slipping. 7. Motor wired incorrectly. 8. Plug/receptacle at fault. 9. Pulley/sprocket slipping on shaft. 10. Motor bearings at fault. 11. Contactor not energized/has poor contacts. 12. Motor overheated. 13. Motor at fault. 	<ol style="list-style-type: none"> 1. Decrease feed rate/cutting speed. 2. Only cut wood/ensure moisture is below 20%. 3. Straighten or replace workpiece/adjust fence. 4. Use correct blade/reduce feed rate or depth of cut. 5. Test/repair/replace. 6. Tension/replace belt (Page 74). 7. Wire motor correctly. 8. Test for good contacts/correct wiring. 9. Replace loose pulley/shaft. 10. Test/repair/replace. 11. Test all legs for power/replace if faulty. 12. Clean motor, let cool, and reduce workload. 13. Test/repair/replace.
Machine has vibration or noisy operation.	<ol style="list-style-type: none"> 1. Motor or component loose. 2. Blade at fault. 3. Belts worn or loose. 4. Pulley loose. 5. Motor mount loose/broken. 6. Machine incorrectly mounted. 7. Arbor pulley loose. 8. Motor fan rubbing on fan cover. 9. Arbor bearings at fault. 10. Motor bearings at fault. 	<ol style="list-style-type: none"> 1. Inspect/replace damaged bolts/nuts, and re-tighten with thread locking fluid. 2. Replace warped/bent blade; sharpen dull blade. 3. Tension/replace belts (Page 74). 4. Realign/replace shaft, pulley, setscrew, and key. 5. Tighten/replace. 6. Tighten mounting bolts; relocate/shim machine. 7. Retighten/replace arbor pulley. 8. Fix/replace fan cover; replace loose/damaged fan. 9. Replace arbor housing bearings; replace arbor. 10. Test by rotating shaft; grinding/loose shaft requires bearing replacement.

SERVICE

Symptom	Possible Cause	Possible Solution
Blade is not aligned with miter slot or fence.	<ol style="list-style-type: none"> 1. Blade is warped. 2. Table top is not parallel to blade. 3. Fence is not parallel to blade. 	<ol style="list-style-type: none"> 1. Replace blade (Page 35). 2. Make table parallel to blade (Page 67). 3. Make fence parallel to blade (Page 70).
Blade does not reach 90°.	<ol style="list-style-type: none"> 1. 90° stop bolt is out of adjustment. 2. Sawdust stuck on stop bolt. 	<ol style="list-style-type: none"> 1. Adjust 90° stop bolt (Page 65). 2. Clean sawdust off stop bolt.
Blade hits insert at 45°.	<ol style="list-style-type: none"> 1. 45° stop bolt is out of adjustment. 2. Sawdust stuck on stop bolt. 3. Hole in insert is inadequate. 4. Table out of alignment. 5. Blade position is incorrect. 	<ol style="list-style-type: none"> 1. Adjust 45° stop bolt (Page 65). 2. Clean sawdust off stop bolt. 3. File or mill the hole in the insert. 4. Align blade to the table (Page 67). 5. Adjust blade position.
Board binds or burns when feeding through table saw.	<ol style="list-style-type: none"> 1. Dull blade. 2. Blade is warped. 3. Fence is not parallel to blade. 4. Table top is not parallel to blade. 	<ol style="list-style-type: none"> 1. Replace blade. 2. Replace blade (Page 35). 3. Make fence parallel to blade (Page 70). 4. Make table parallel to blade (Page 67).

PARTS

Body

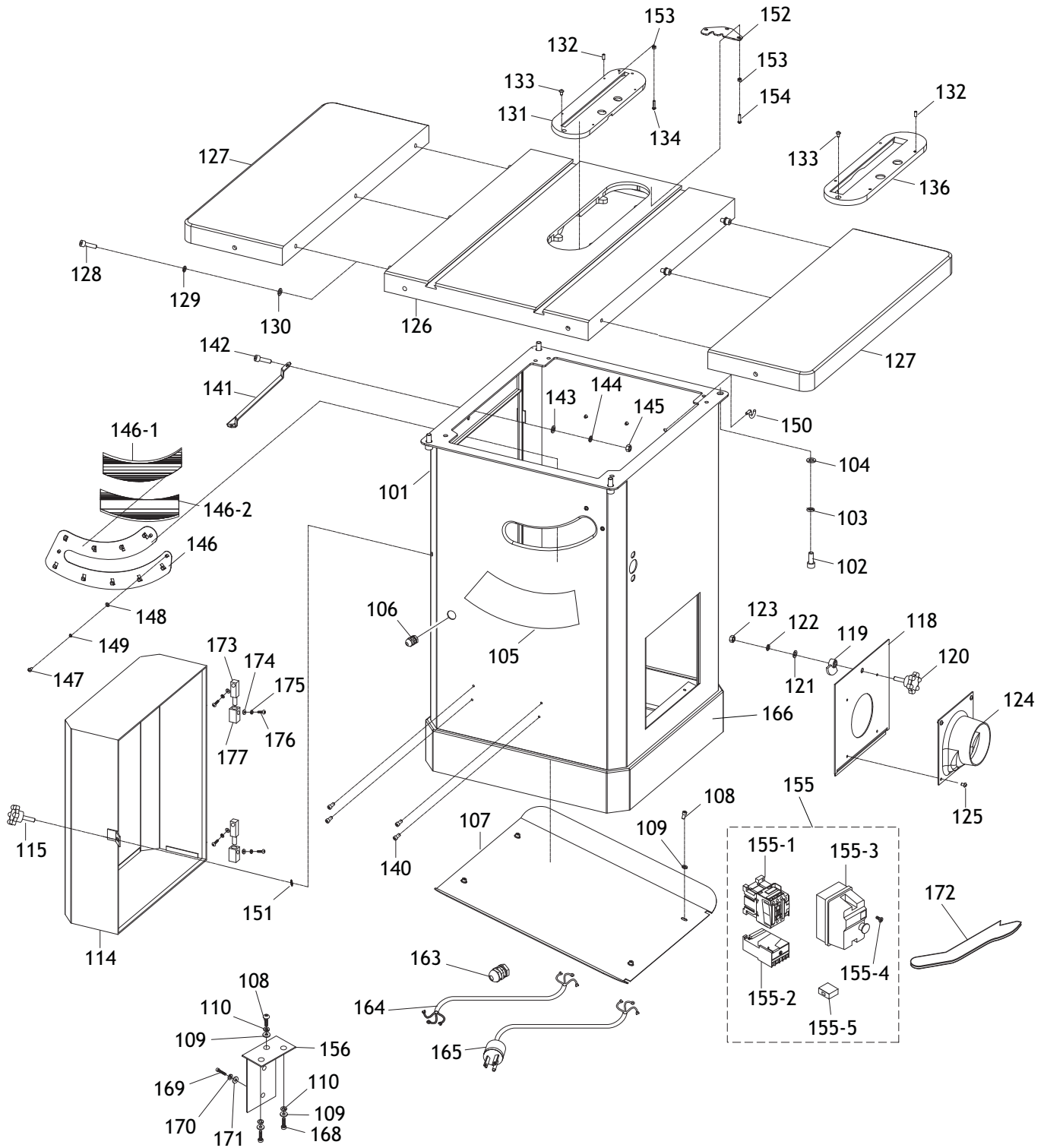

Body Parts List

REF	PART #	DESCRIPTION
101	X1819101	CABINET STAND
102	XPCAP88M	CAP SCREW M10-1.25 X 25
103	XPLW06M	LOCK WASHER 10MM
104	XPW04M	FLAT WASHER 10MM
105	X1819105	TILT SCALE
106	X1819106	STRAIN RELIEF
107	X1819107	BASE PLATE
108	XPS14M	PHLP HD SCR M6-1 X 12
109	XPW03M	FLAT WASHER 6MM
110	XPLW03M	LOCK WASHER 6MM
114	X1819114	MOTOR COVER
115	X1819115	KNOB BOLT M6-1
118	X1819118	CLEAN-OUT DOOR
119	X1819119	DOOR LATCH
120	X1819120	KNOB BOLT M8-1.25
121	XPW01M	FLAT WASHER 8MM
122	XPLW04M	LOCK WASHER 8MM
123	XPNO3M	HEX NUT M8-1.25
124	X1819124	DUST HOOD
125	XPS05M	PHLP HD SCR M5-.8 X 8
126	X1819126	TABLE
127	X1819127	EXTENSION WING
128	XPCAP13M	CAP SCREW M8-1.25 X 30
129	XPLW04M	LOCK WASHER 8MM
130	XPW01M	FLAT WASHER 8MM
131	X1819131	STANDARD TABLE INSERT
132	XPSS53M	SET SCREW M5-.8 X 12
133	XPS08M	PHLP HD SCR M5-.8 X 12
134	XPS06M	PHLP HD SCR M5-.8 X 20
136	X1819136	DADO TABLE INSERT
140	XPRIV004M	STEEL BLIND RIVET 4 X 10MM
141	X1819141	SHIPPING BRACE
142	XPB74M	HEX BOLT M10-1.5 X 20
143	XPW04M	FLAT WASHER 10MM

REF	PART #	DESCRIPTION
144	XPLW06M	LOCK WASHER 10MM
145	XPNO2M	HEX NUT M10-1.5
146	X1819146	DUST SHIELD
146-1	X1819146-1	UPPER BRUSH
146-2	X1819146-2	LOWER BRUSH
147	XPS02M	PHLP HD SCR M4-.7 X 12
148	XPW05M	FLAT WASHER 4MM
149	XPLW02M	LOCK WASHER 4MM
150	X1819150	HOOK
151	XPTLW13M	INT TOOTH WASHER 6MM
152	X1819152	LIMIT PLATE
153	XPNO6M	HEX NUT M5-.8
154	XPS06M	PHLP HD SCR M5-.8 X 20
155	X1819155	MAG SWITCH ASSEMBLY MS-15
155-1	X1819155-1	CONTACTOR CHINT NC1-18
155-2	X1819155-2	OL RELAY CHINT NR2-25 12-18
155-3	X1819155-3	SWITCH BOX FRONT/BACK
155-4	X1819155-4	MAG SWITCH COVER SCREW
155-5	X1819155-5	ON/OFF SWITCH CHINT NP2
156	X1819156	SWITCH BRACKET
163	X1819163	STRAIN RELIEF
164	X1819164	MOTOR CORD 14AWG 3C
165	X1819165	POWER CORD W/PLUG
166	X1819166	BLACK TRIM TAPE
168	XPB02M	HEX BOLT M6-1 X 12
169	XPBHS16M	BUTTON HD CAP SCR M5-.8 X 16
170	XPLW01M	LOCK WASHER 5MM
171	XPW02M	FLAT WASHER 5MM
172	X1819172	PUSH STICK
173	X1819173	UPPER HINGE BLOCK
174	XPW02M	FLAT WASHER 5MM
175	XPLW01M	LOCK WASHER 5MM
176	XPBHS06M	BUTTON HD CAP SCR M5-.8 X 12
177	X1819177	LOWER HINGE BLOCK

Trunnion

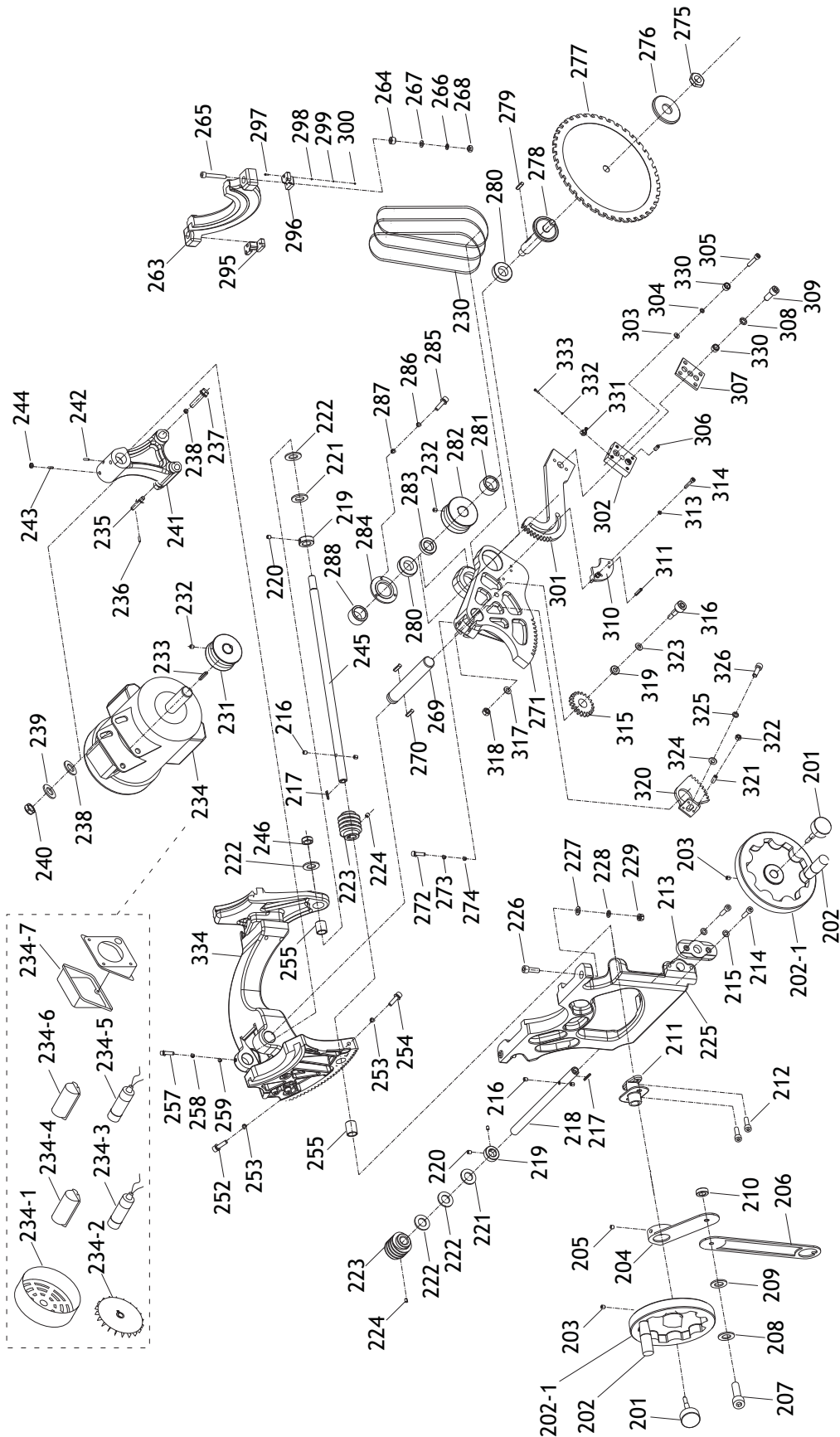

Trunnion Parts List

REF	PART #	DESCRIPTION
201	X1819201	HANDWHEEL LOCK KNOB
202	X1819202	HANDWHEEL HANDLE
202-1	X1819202-1	HANDWHEEL
203	XPSS53M	SET SCREW M5-.8 X 12
204	X1819204	TILT POINTER PIVOT
205	XPSS26M	SET SCREW M5-.8 X 6
206	X1819206	TILT POINTER
207	XPCAP25M	CAP SCREW M6-1 X 12
208	XPLW03M	LOCK WASHER 6MM
209	XPW03M	FLAT WASHER 6MM
210	XPNO1M	HEX NUT M6-1
211	X1819211	TILT POINTER BRACKET
212	XPCAP38M	CAP SCREW M5-.8 X 25
213	X1819213	TILT SHAFT BRACKET
214	XPCAP31M	CAP SCREW M8-1.25 X 25
215	XPLW04M	LOCK WASHER 8MM
216	X1819216	SHAFT PIN
217	XPK170M	KEY 5 X 5 X 36
218	X1819218	TILT SHAFT
219	X1819219	LOCK COLLAR
220	XPSS03M	SET SCREW M6-1 X 8
221	XPLW12M	LOCK WASHER 18MM
222	X1819222	COPPER WASHER 18MM
223	X1819223	WORM
224	XPSS01M	SET SCREW M6-1 X 10
225	X1819225	FRONT TRUNNION
226	XPCAP72M	CAP SCREW M10-1.5 X 30
227	XPW04M	FLAT WASHER 10MM
228	XPLW06M	LOCK WASHER 10MM
229	XPNO2M	HEX NUT M10-1.5
230	X1819230	BELT SPZ 625
231	X1819231	MOTOR PULLEY
232	XPSS53M	SET SCREW M5-.8 X 12
233	XPK12M	KEY 5 X 5 X 30
234	X1819234	MOTOR 3HP 220V 1PH
234-1	X1819234-1	MOTOR FAN COVER
234-2	X1819234-2	MOTOR FAN
234-3	X1819234-3	R CAPACITOR 25M 370V 1-3/4 X 3
234-4	X1819234-4	R CAPACITOR COVER
234-5	X1819234-5	S CAP 200M 250V 1-1/4 X 2-3/4
234-6	X1819234-6	S CAPACITOR COVER
234-7	X1819234-7	MOTOR JUNCTION BOX
235	X1819235	ORIENTATION PIN
236	XPRP108M	ROLL PIN 4 X 28
237	XPB121M	HEX BOLT M12-1.75 X 100
238	XPW06M	FLAT WASHER 12MM
239	XPLW05M	LOCK WASHER 12MM
240	XPNO9M	HEX NUT M12-1.75
241	X1819241	MOTOR FRAME SUPPORT

REF	PART #	DESCRIPTION
242	XPSS14M	SET SCREW M8-1.25 X 12
243	XPSS19M	SET SCREW M8-1.25 X 30
244	XPNO3M	HEX NUT M8-1.25
245	X1819245	ELEVATION SHAFT
246	XPLN14M	LOCK NUT M18-1.5
252	XPB09M	HEX BOLT M8-1.25 X 20
253	XPNO3M	HEX NUT M8-1.25
254	XPB20M	HEX BOLT M8-1.25 X 35
255	X1819255	SHAFT SLEEVE
257	XPSS20M	SET SCREW M8-1.25 X 8
258	X1819258	COMPRESSION SPRING
259	XPSTB002M	STEEL BALL 8MM
263	X1819263	REAR TRUNNION
264	X1819264	SPACER
265	XPCAP13M	CAP SCREW M8-1.25 X 30
266	XPW01M	FLAT WASHER 8MM
267	XPLW04M	LOCK WASHER 8MM
268	XPNO3M	HEX NUT M8-1.25
269	X1819269	PIVOT SHAFT
270	XPK44M	KEY 6 X 6 X 50
271	X1819271	PIVOT BRACKET
272	XPB116M	HEX BOLT M10-1.5 X 45
273	XPLW06M	LOCK WASHER 10MM
274	XPW04M	FLAT WASHER 10MM
275	X1819275	ARBOR NUT
276	X1819276	ARBOR FLANGE
277	X1819277	BLADE 10" 40TPI 5/8" BORE
278	X1819278	BLADE ARBOR
279	XPK12M	KEY 5 X 5 X 30
280	XP6005ZZ	BALL BEARING 6005ZZ
281	X1819281	FRONT PULLEY SPACER
282	X1819282	ARBOR PULLEY
283	X1819283	REAR PULLEY SPACER
284	X1819284	FLANGE RING
285	XPS08M	PHLP HD SCR M5-.8 X 12
286	XPLW01M	LOCK WASHER 5MM
287	XPW02M	FLAT WASHER 5MM
288	XPLN15M	LOCK NUT M16-1.5
295	X1819295	REAR TRUNNION BRACKET
296	X1819296	FRONT TRUNNION BRACKET
297	XPCAP13M	CAP SCREW M8-1.25 X 30
298	XPW01M	FLAT WASHER 8MM
299	XPLW04M	LOCK WASHER 8MM
300	XPNO3M	HEX NUT M8-1.25
301	X1819301	BULL GEAR
302	X1819302	SPLITTER ADJUSTMENT BLOCK
303	XPW03M	FLAT WASHER 6MM
304	XPLW03M	LOCK WASHER 6MM
305	XPCAP06M	CAP SCREW M6-1 X 25

Trunnion Parts List

REF	PART #	DESCRIPTION
306	XPSS04M	SET SCREW M6-1 X 12
307	X1819307	SPLITTER LOCK PLATE
308	XPLW03M	LOCK WASHER 6MM
309	XPB08M	HEX BOLT M6-1 X 20
310	X1819310	ORIENTATION PLATE
311	XPRP49M	ROLL PIN 5 X 25
313	XPLW01M	LOCK WASHER 5MM
314	XPCAP38M	CAP SCREW M5-.8 X 25
315	X1819315	GEAR
316	XPCAP47M	CAP SCREW M10-1.5 X 40
317	XPW04M	FLAT WASHER 10MM
318	XLN05M	LOCK NUT M10-1.5
319	X1819319	GEAR BUSHING

REF	PART #	DESCRIPTION
320	X1819320	PLATE GEAR
321	XPSS25M	SET SCREW M6-1 X 20
322	XPNO1M	HEX NUT M6-1
323	XPWF10M	FENDER WASHER 10MM
324	XPW01M	FLAT WASHER 8MM
325	XPLW04M	LOCK WASHER 8MM
326	XPCAP14M	CAP SCREW M8-1.25 X 20
330	X1819330	SPACER
331	X1819331	POSITION PIN ASSEMBLY
332	XPLW02M	LOCK WASHER 4MM
333	XPSS22M	SET SCREW M4-.7 X 12
334	X1819334	MAIN TRUNNION

Blade Guard

401AV3

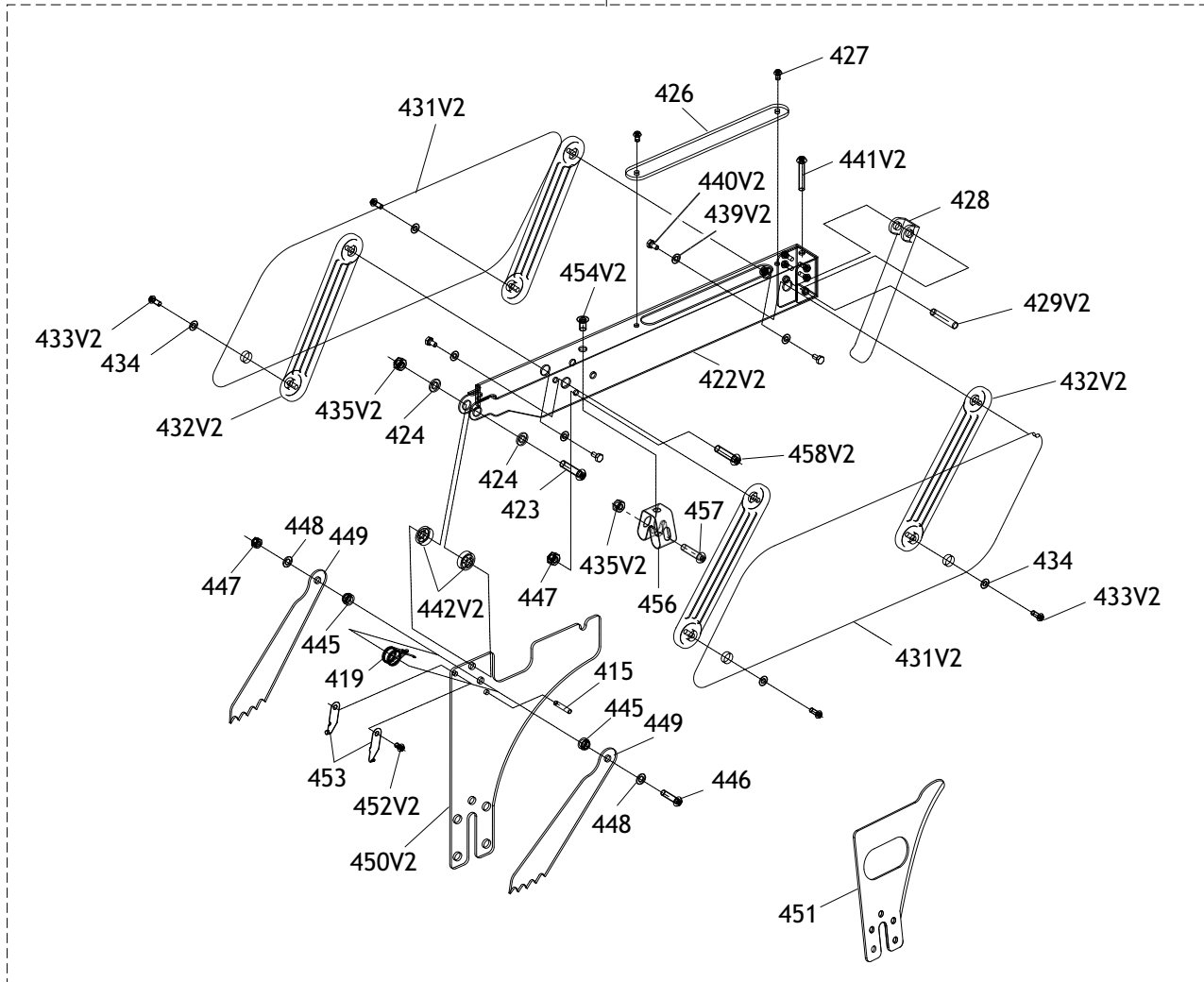

REF	PART #	DESCRIPTION
401AV3	X1819401AV3	BLADE GUARD ASSEMBLY V3.02.11
415	XPRP39M	ROLL PIN 4 X 20
419	X1819419	TORSION SPRING
422V2	X1819422V2	SUPPORT ARM V2.10.10
423	XPS47M	PHLP HD SCR M6-1 X 25
424	XPW03M	FLAT WASHER 6MM
426	X1819426	TOP GUARD PLASTIC
427	XPS17M	PHLP HD SCR M4-.7 X 6
428	X1819428	FRONT GUARD PLASTIC
429V2	X1819429V2	ROLL PIN 6 X 32
431V2	X1819431V2	SIDE GUARD PLASTIC V2.10.10
432V2	X1819432V2	GUARD SWING ARM V2.10.10
433V2	XPS38M	PHLP HD SCR M4-.7 X 10
434	XPW02M	FLAT WASHER 5MM
435V2	XPLN03M	LOCK NUT M6-1
439V2	XPW02M	FLAT WASHER 5MM

REF	PART #	DESCRIPTION
440V2	XPB122M	HEX BOLT M4-.7 X 8
441V2	XPS62M	PHLP HD SCR M6-1 X 30
442V2	X1819442V2	GUARD SPACER V2.10.10
445	X1819445	PAWL SPACER
446	XPB42M	HEX BOLT M5-.8 X 20
447	XPLN02M	LOCK NUT M5-.8
448	XPW02M	FLAT WASHER 5MM
449	X1819449	PAWL
450V2	X1819450V2	SPREADER V2.10.10
451	X1819451	RIVING KNIFE
452V2	X1819452V2	RIVET V2.02.11
453	X1819453	PAWL HOOK 2-PC
454V2	X1819454V2	RIVET 5 X 12MM V2.02.11
456	X1819456	GUARD CLAMP
457	XPS531M	PHLP HD SCR M6-1 X 35
458V2	XPB11M	HEX BOLT M5-.8 X 8

Miter Gauge

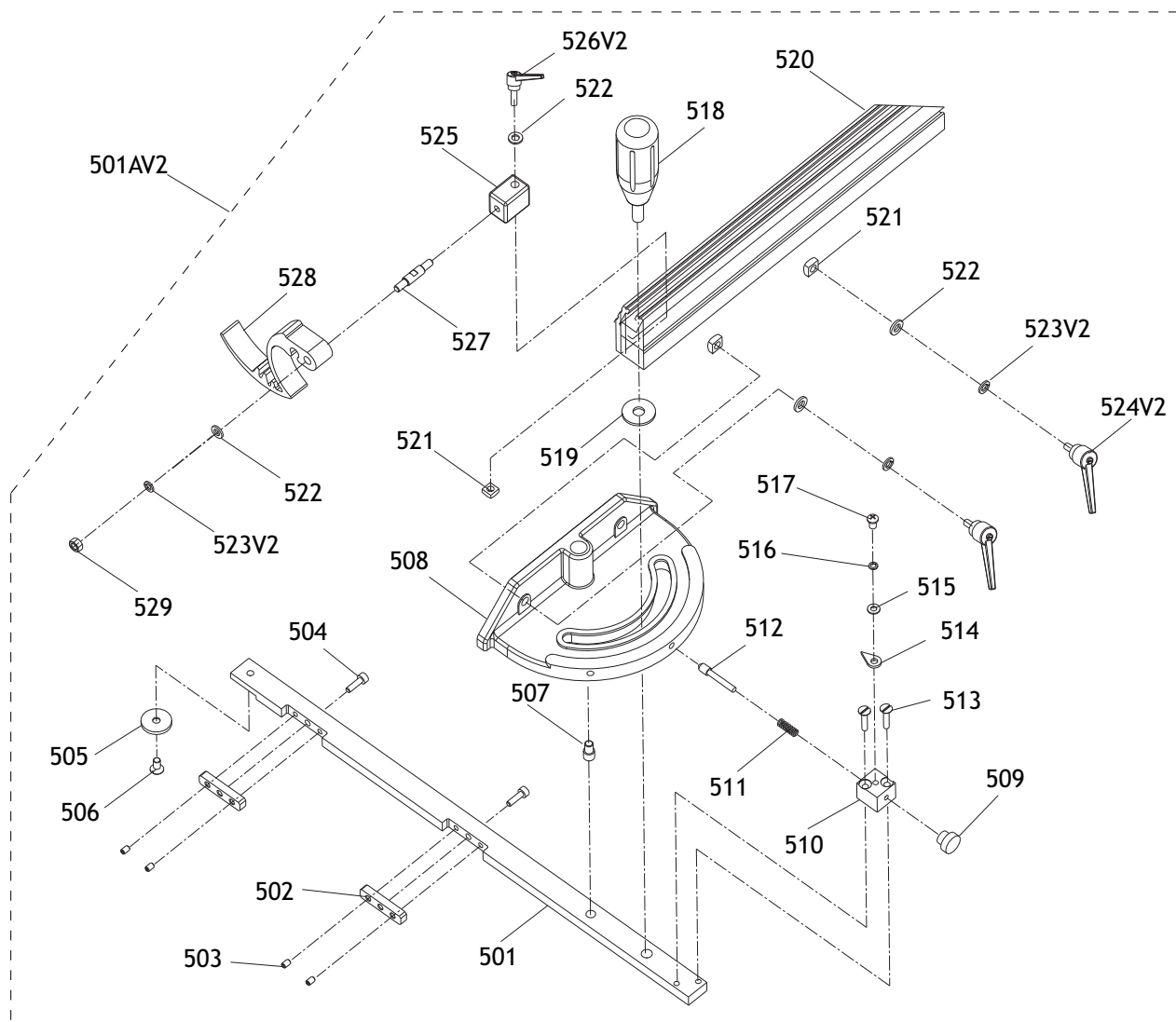

REF	PART #	DESCRIPTION
501AV2	X1819501AV2	MITER GAUGE ASSEMBLY V2.12.10
501	X1819501	MITER BAR
502	X1819502	GIB
503	XPSS79M	SET SCREW M4-.7 X 6
504	XPCAP41M	CAP SCREW M4-.7 X 14
505	X1819505	T-SLOT WASHER
506	XPFH30M	FLAT HD SCR M5-.8 X 8
507	X1819507	MITER BODY PIVOT PIN
508	X1819508	MITER GAUGE BODY
509	X1819509	STOP PIN KNOB
510	X1819510	STOP PIN BLOCK
511	X1819511	COMPRESSION SPRING
512	X1819512	STOP PIN
513	XPFH77M	FLAT HD SCR M4-.7 X 20
514	X1819514	POINTER

REF	PART #	DESCRIPTION
515	XPW05M	FLAT WASHER 4MM
516	XPLW02M	LOCK WASHER 4MM
517	XPS07M	PHLP HD SCR M4-.7 X 8
518	X1819518	MITER KNOB
519	X1819519	FENDER WASHER 8MM
520	X1819520	MITER GAUGE FENCE
521	X1819521	T-NUT M6-1
522	XPW03M	FLAT WASHER 6MM
523V2	X1819523V2	PLASTIC WASHER 6MM
524V2	X1819524V2	LOCK LEVER M6-1 X 25 V2.12.10
525	X1819525	FLIP STOP BRACKET
526V2	X1819526V2	LOCK LEVER M6-1 X 32 V2.12.10
527	X1819527	FLIP STOP PIVOT SHAFT
528	X1819528	FLIP STOP
529	XPLN03M	LOCK NUT M6-1

Fence

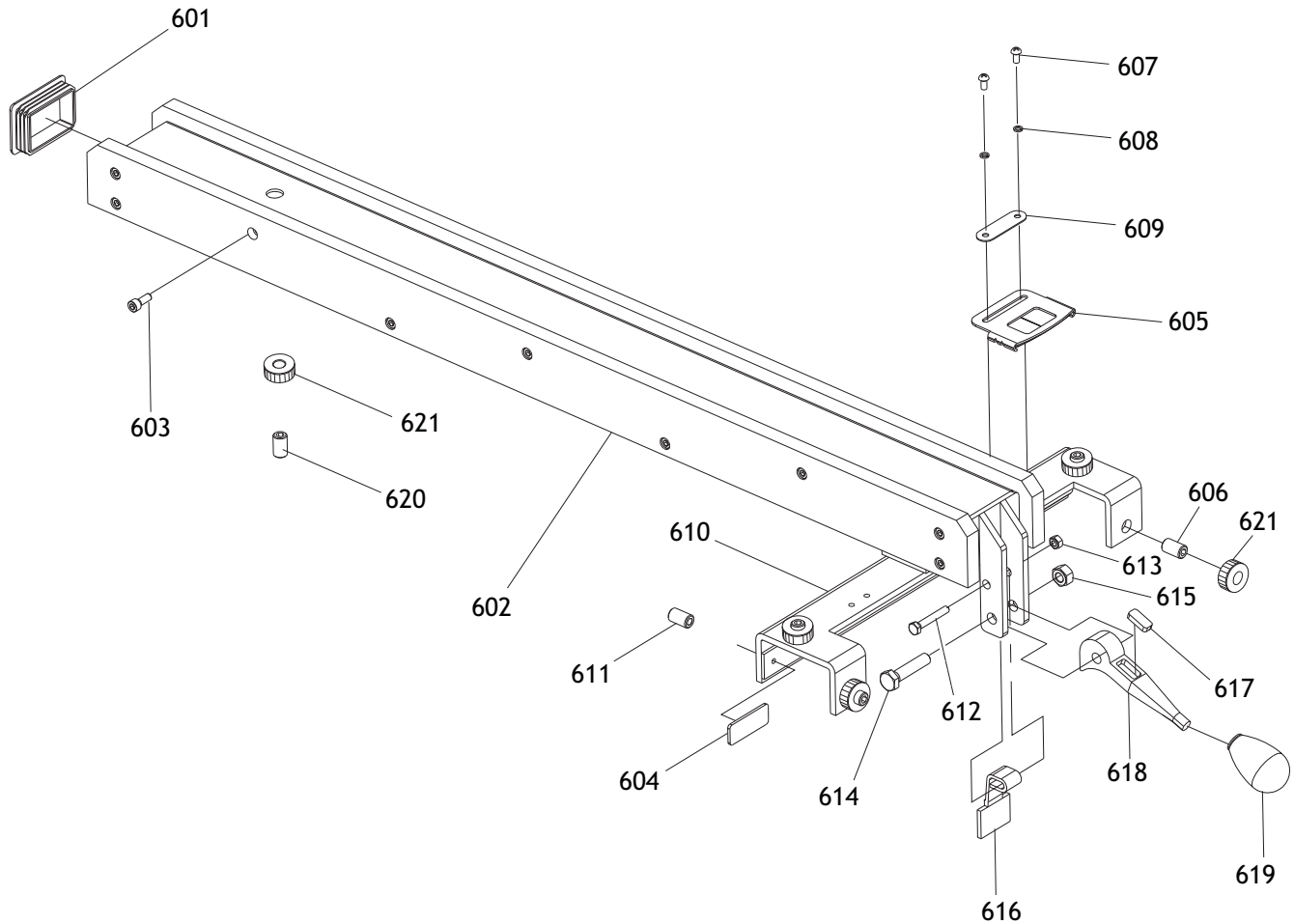

REF	PART #	DESCRIPTION
601	X1819601	FENCE END CAP
602	X1819602	FENCE FACE
603	XPCAP01M	CAP SCREW M6-1 X 16
604	X1819604	GLIDE PAD
605	X1819605	FENCE SCALE WINDOW
606	XPSS109M	SET SCREW M12-1.75 X 16
607	XPS09M	PHLP HD SCR M5-.8 X 10
608	XPLW01M	LOCK WASHER 5MM
609	X1819609	SCALE INDICATOR
610	X1819610	FENCE BODY
611	X1819611	ALIGNMENT SET SCREW

REF	PART #	DESCRIPTION
612	XPB47M	HEX BOLT M6-1 X 40
613	XPLN03M	LOCK NUT M6-1
614	XPB116M	HEX BOLT M10-1.5 X 45
615	XPLN05M	LOCK NUT M10-1.5
616	X1819616	LOCK FOOT
617	X1819617	MAGNET
618	X1819618	FENCE LOCK LEVER
619	X1819619	FENCE LOCK KNOB
620	XPSS32M	SET SCREW M12-1.75 X 30
621	X1819621	KNURLED KNOB M12-1.75

W1819 Extension Wing & Rails

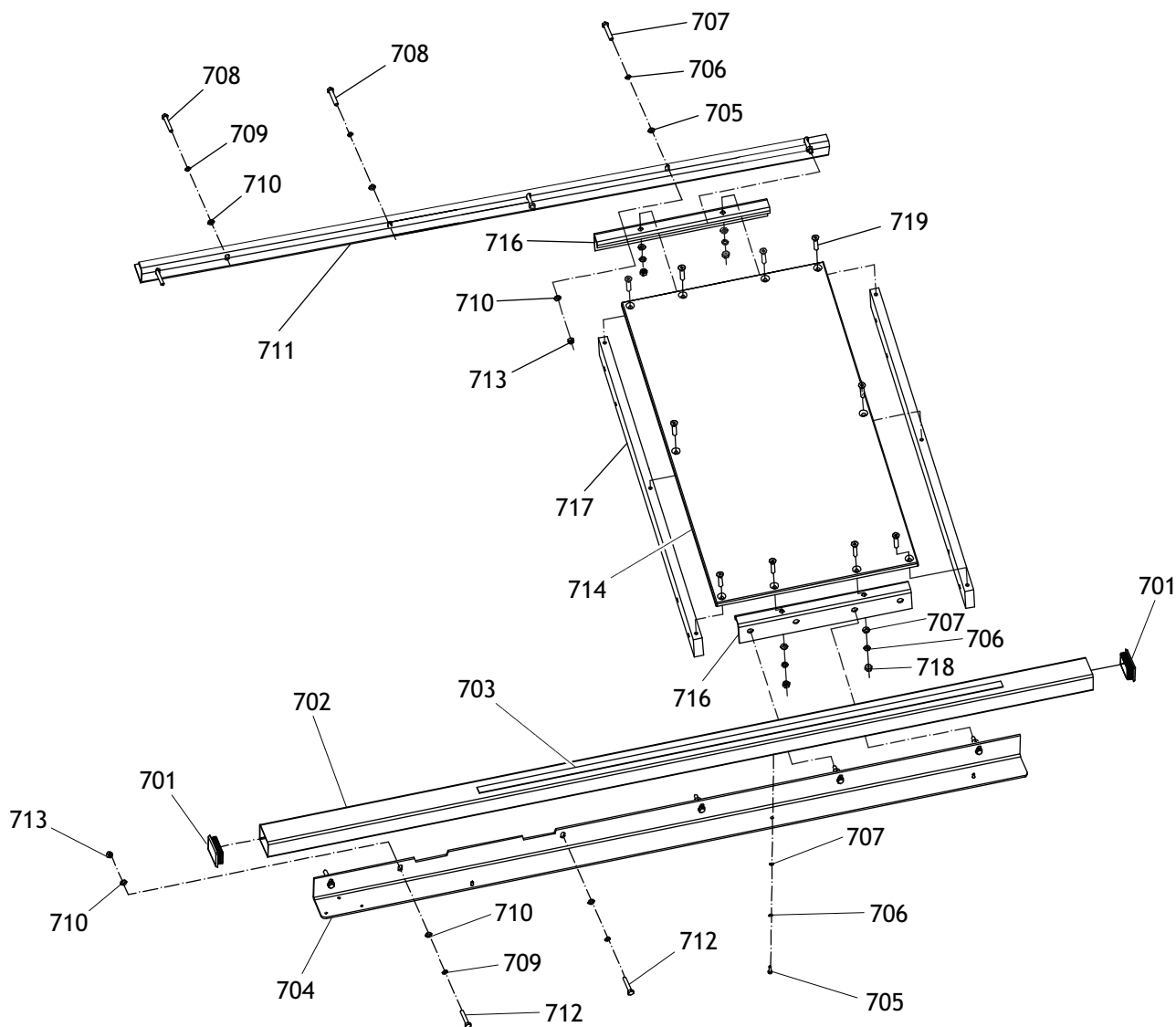

REF	PART #	DESCRIPTION
701	X1819701	GUIDE TUBE END CAP
702	X1819702	GUIDE TUBE
703	X1819703	FENCE SCALE
704	X1819704	FRONT RAIL
705	XPCAP01M	CAP SCREW M6-1 X 16
706	XPLW03M	LOCK WASHER 6MM
707	XPW03M	FLAT WASHER 6MM
708	XPB26M	HEX BOLT M8-1.25 X 30
709	XPLW04M	LOCK WASHER 8MM

REF	PART #	DESCRIPTION
710	XPW01M	FLAT WASHER 8MM
711	X1819711	REAR RAIL
712	XPB15M	HEX BOLT M8-1.25 X 40
713	XPN03M	HEX NUT M8-1.25
714	X1819714	EXTENSION WING
716	X1819716	LONGITUDINAL EXTENSION SUPPORT
717	X1819717	CROSS EXTENSION SUPPORT
718	XPN01M	HEX NUT M6-1
719	XPFH12M	FLAT HD SCR M6-1 X 25

W1820 Extension Wing & Rails

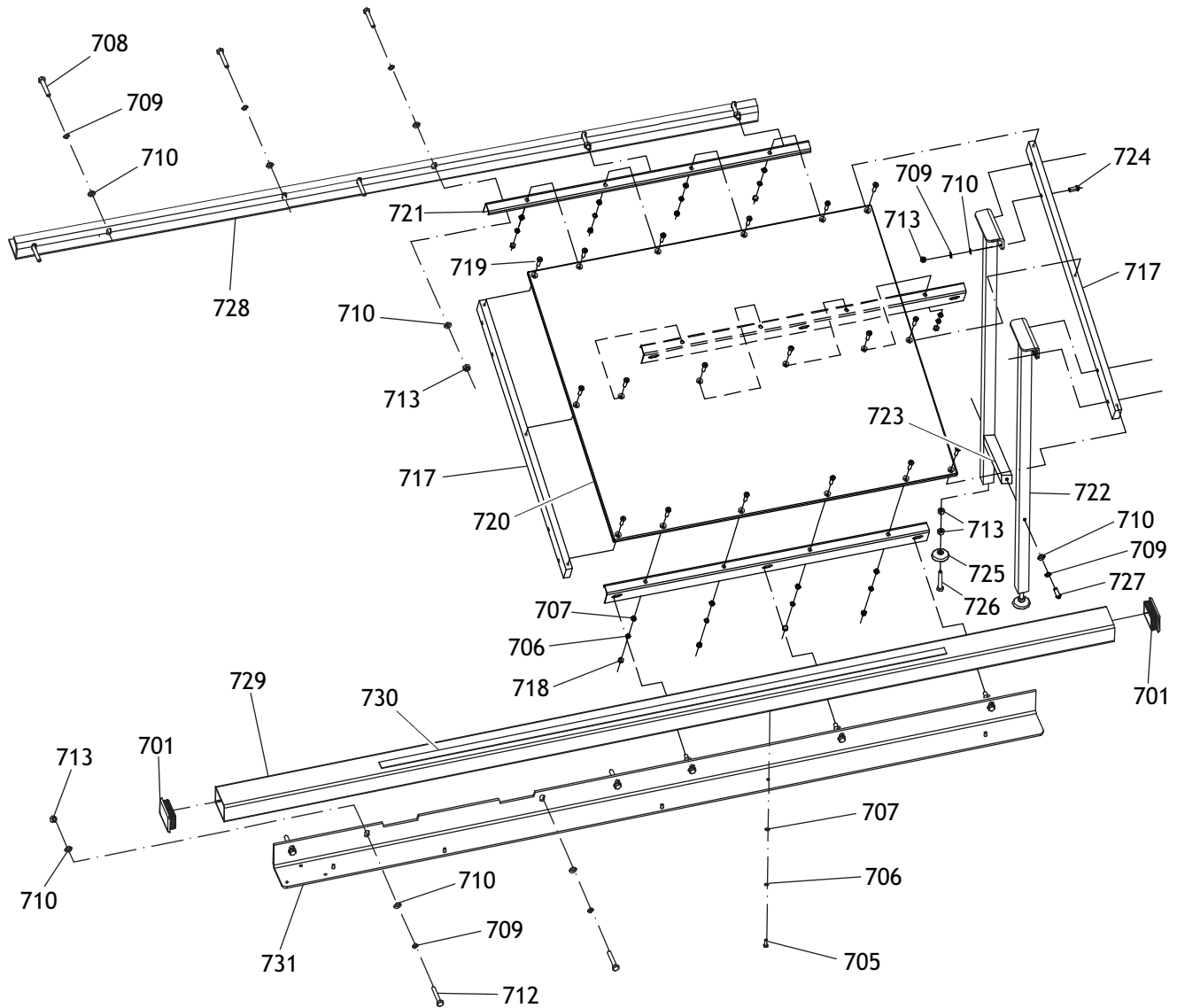

REF	PART #	DESCRIPTION
701	X1820701	GUIDE TUBE END CAP
705	XPCAP01M	CAP SCREW M6-1 X 16
706	XPLW03M	LOCK WASHER 6MM
707	XPW03M	FLAT WASHER 6MM
708	XPB26M	HEX BOLT M8-1.25 X 30
709	XPLW04M	LOCK WASHER 8MM
710	XPW01M	FLAT WASHER 8MM
712	XPB15M	HEX BOLT M8-1.25 X 40
713	XPN03M	HEX NUT M8-1.25
717	X1820717	CROSS EXTENSION SUPPORT
718	X1820718	HEX NUT M6-1.25
719	XPFH12M	FLAT HD SCR M6-1 X 25

REF	PART #	DESCRIPTION
720	X1820720	EXTENSION WING
721	X1820721	LONGITUDINAL EXTENSION SUPPORT
722	X1820722	LEG
723	X1820723	LEG CROSS BAR
724	XPBHS20M	BUTTON HD CAP SCR M8-1.25 X 30
725	X1820725	FOOT
726	XPB28M	HEX BOLT M8-1.25 X 60
727	XPBHS07M	BUTTON HD CAP SCR M8-1.25 X 40
728	X1820728	REAR RAIL
729	X1820729	GUIDE TUBE
730	X1820730	FENCE SCALE
731	X1820731	FRONT RAIL

Machine Labels

! WARNING

Safety labels warn about machine hazards and how to prevent machine damage or injury. The owner of this machine **MUST** maintain the original location and readability of all labels on this machine. If any label is removed or becomes unreadable, **REPLACE** that label before allowing the machine to enter service again. Contact Woodstock International, Inc. at (360) 734-3482 or www.shopfoxtools.com to order new labels.



REF	PART #	DESCRIPTION
801	XLABEL-04	ELECTRICITY LABEL
802	X1819802	TABLE SAW PRECAUTIONS LABEL
803	X1819803	BLADE GUARD WARNING LABEL
804	X1819804	RIP FENCE LABEL
805	X1819805	EYE INJURY HAZARD LABEL
806	D3377	SHOP FOX NAMEPLATE

REF	PART #	DESCRIPTION
807	X1819807	MODEL NUMBER LABEL (W1819)
807	X1820807	MODEL NUMBER LABEL (W1820)
808	X1819808	MACHINE ID LABEL (W1819)
808	X1820808	MACHINE ID LABEL (W1820)
809	X1819809	DISCONNECT POWER LABEL
810	X1819810	MOTOR COVER WARNING LABEL



Warranty Registration

Name _____
 Street _____
 City _____ State _____ Zip _____
 Phone # _____ Email _____ Invoice # _____
 Model # _____ Serial # _____ Dealer Name _____ Purchase Date _____

The following information is given on a voluntary basis. It will be used for marketing purposes to help us develop better products and services. **Of course, all information is strictly confidential.**

1. How did you learn about us?

<input type="checkbox"/> Advertisement	<input type="checkbox"/> Friend	<input type="checkbox"/> Local Store
<input type="checkbox"/> Mail Order Catalog	<input type="checkbox"/> Website	<input type="checkbox"/> Other:

2. How long have you been a woodworker/metalworker?

<input type="checkbox"/> 0-2 Years	<input type="checkbox"/> 2-8 Years	<input type="checkbox"/> 8-20 Years	<input type="checkbox"/> 20+ Years
------------------------------------	------------------------------------	-------------------------------------	------------------------------------

3. How many of your machines or tools are Shop Fox?

<input type="checkbox"/> 0-2	<input type="checkbox"/> 3-5	<input type="checkbox"/> 6-9	<input type="checkbox"/> 10+
------------------------------	------------------------------	------------------------------	------------------------------

4. Do you think your machine represents a good value? Yes No

5. Would you recommend Shop Fox products to a friend? Yes No

6. What is your age group?

<input type="checkbox"/> 20-29	<input type="checkbox"/> 30-39	<input type="checkbox"/> 40-49
<input type="checkbox"/> 50-59	<input type="checkbox"/> 60-69	<input type="checkbox"/> 70+

7. What is your annual household income?

<input type="checkbox"/> \$20,000-\$29,000	<input type="checkbox"/> \$30,000-\$39,000	<input type="checkbox"/> \$40,000-\$49,000
<input type="checkbox"/> \$50,000-\$59,000	<input type="checkbox"/> \$60,000-\$69,000	<input type="checkbox"/> \$70,000+

8. Which of the following magazines do you subscribe to?

<input type="checkbox"/> Cabinet Maker	<input type="checkbox"/> Popular Mechanics	<input type="checkbox"/> Today's Homeowner
<input type="checkbox"/> Family Handyman	<input type="checkbox"/> Popular Science	<input type="checkbox"/> Wood
<input type="checkbox"/> Hand Loader	<input type="checkbox"/> Popular Woodworking	<input type="checkbox"/> Wooden Boat
<input type="checkbox"/> Handy	<input type="checkbox"/> Practical Homeowner	<input type="checkbox"/> Woodshop News
<input type="checkbox"/> Home Shop Machinist	<input type="checkbox"/> Precision Shooter	<input type="checkbox"/> Woodsmith
<input type="checkbox"/> Journal of Light Cont.	<input type="checkbox"/> Projects in Metal	<input type="checkbox"/> Woodwork
<input type="checkbox"/> Live Steam	<input type="checkbox"/> RC Modeler	<input type="checkbox"/> Woodworker West
<input type="checkbox"/> Model Airplane News	<input type="checkbox"/> Rifle	<input type="checkbox"/> Woodworker's Journal
<input type="checkbox"/> Modeltec	<input type="checkbox"/> Shop Notes	<input type="checkbox"/> Other:
<input type="checkbox"/> Old House Journal	<input type="checkbox"/> Shotgun News	

9. Comments: _____

CUT ALONG DOTTED LINE

FOLD ALONG DOTTED LINE

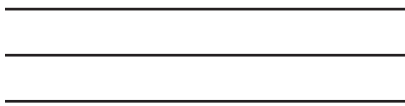

Place
Stamp
Here



WOODSTOCK INTERNATIONAL INC.
P.O. BOX 2309
BELLINGHAM, WA 98227-2309



FOLD ALONG DOTTED LINE

TAPE ALONG EDGES--PLEASE DO NOT STAPLE

WARRANTY

Woodstock International, Inc. warrants all Shop Fox machinery to be free of defects from workmanship and materials for a period of two years from the date of original purchase by the original owner. This warranty does not apply to defects due directly or indirectly to misuse, abuse, negligence or accidents, lack of maintenance, or reimbursement of third party expenses incurred.

Woodstock International, Inc. will repair or replace, at its expense and at its option, the Shop Fox machine or machine part, which in normal use has proven to be defective, provided that the original owner returns the product prepaid to a Shop Fox factory service center with proof of their purchase of the product within two years, and provides Woodstock International, Inc. reasonable opportunity to verify the alleged defect through inspection. If it is determined there is no defect, or that the defect resulted from causes not within the scope of Woodstock International Inc.'s warranty, then the original owner must bear the cost of storing and returning the product.

This is Woodstock International, Inc.'s sole written warranty and any and all warranties that may be implied by law, including any merchantability or fitness, for any particular purpose, are hereby limited to the duration of this written warranty. We do not warrant that Shop Fox machinery complies with the provisions of any law or acts. In no event shall Woodstock International, Inc.'s liability under this warranty exceed the purchase price paid for the product, and any legal actions brought against Woodstock International, Inc. shall be tried in the State of Washington, County of Whatcom. We shall in no event be liable for death, injuries to persons or property or for incidental, contingent, special or consequential damages arising from the use of our products.

Every effort has been made to ensure that all Shop Fox machinery meets high quality and durability standards. We reserve the right to change specifications at any time because of our commitment to continuously improve the quality of our products.



High Quality Machines and Tools

Woodstock International, Inc. carries thousands of products designed to meet the needs of today's woodworkers and metalworkers. Ask your dealer about these fine products:

BROSENA
PRECISION STOP BLOCK

JOINTER PAL[®]

Rotacator[®]

THE REBEL[®]

DURASTICK[®]

Gutmann[®]

BOARD BUDDIES[®]



Junglee[®]

PLANER PAL[®]

PARROT VISE[®]

SLICKPLANE[®]

PRO-STIK[®]
ABRASIVE BELT & DISC CLEANER

ACCU-SHARP[®]

Aluma-Classic[®]



STEELEX[®]
FINE TOOLS

STEELEX[®]
PLUS



WHOLESALE ONLY

WOODSTOCK INTERNATIONAL, INC.

Phone: (360) 734-3482 • Fax: (360) 671-3053 • Toll Free Fax: (800) 647-8801

P.O. Box 2309 • Bellingham, WA 98227

SHOPFOX.BIZ