

# BLACK+ DECKER™

## 7-1/4 IN. COMPOUND MITER SAW INSTRUCTION MANUAL

CATALOG NUMBER  
M1850BD

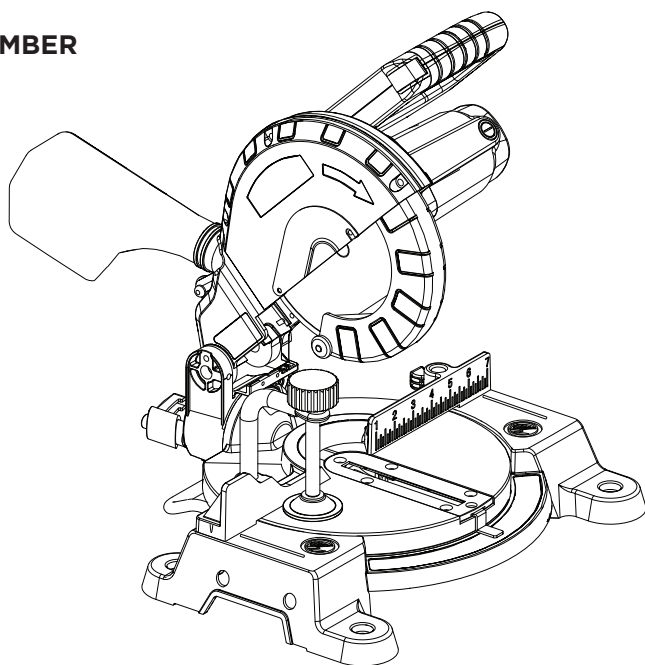

**Thank you for choosing Black+Decker!**

**PLEASE READ BEFORE RETURNING THIS PRODUCT FOR ANY REASON.**

If you have a question or experience a problem with your Black+Decker purchase, go to <http://www.blackanddecker.com/instantanswers>. If you can't find the answer or do not have access to the Internet, call 1-844-437-5095 from 8:30 am to 5 p.m. EST Mon. - Fri. to speak with an agent. Please have the catalog number available when you call.

**SAVE THIS MANUAL FOR FUTURE REFERENCE.**

VEA EL ESPAÑOL EN LA CONTRAPORTADA.

INSTRUCTIVO DE OPERACIÓN, CENTROS DE SERVICIO Y PÓLIZA DE GARANTÍA.

ADVERTENCIA: LÉASE ESTE INSTRUCTIVO ANTES DE USAR EL PRODUCTO.

To register your new product, call 1-844-437-5095  
or visit [www.BlackandDecker.com/NewOwner](http://www.BlackandDecker.com/NewOwner)

## SAFETY GUIDELINES - DEFINITIONS

It is important for you to read and understand this manual. The information it contains relates to protecting YOUR SAFETY and PREVENTING PROBLEMS. The symbols below are used to help you recognize this information.

**⚠ DANGER** : Indicates an imminently hazardous situation which, if not avoided, will result in death or serious injury.

**⚠ WARNING** : Indicates a potentially hazardous situation which, if not avoided, could result in death or serious injury.

**⚠ CAUTION** : Indicates a potentially hazardous situation which, if not avoided, may result in minor or moderate injury.

**NOTICE:** Used without the safety alert symbol indicates potentially hazardous situation which, if not avoided, may result in property damage.

## GENERAL POWER TOOL SAFETY RULES

### ⚠ WARNING

- **Read all safety warnings and all instructions.** Failure to follow the warnings and instructions may result in electric shock, fire and/or serious injury.
- **People with electronic devices, such as pacemakers, should consult their physician(s) before using this product.** Operation of electrical equipment in close proximity to a heart pacemaker could cause interference or failure of the pacemaker.

## SAVE ALL WARNINGS AND INSTRUCTIONS FOR FUTURE REFERENCE

The term "power tool" in the warnings refers to your mains-operated (corded) power tool or battery-operated (cordless) power tool.

### 1) WORK AREA SAFETY

- a) **Keep work area clean and well lit.** Cluttered or dark areas invite accidents.
- b) **Do not operate power tools in explosive atmospheres, such as in the presence of flammable liquids, gases or dust.** Power tools create sparks which may ignite the dust or fumes.
- c) **Keep children and bystanders away while operating a power tool.** Distractions can cause you to lose control.

### 2) ELECTRICAL SAFETY

- a) **Power tool plugs must match the outlet. Never modify the plug in any way. Do not use any adapter plugs with earthed (grounded) power tools.** Unmodified plugs and

matching outlets will reduce risk of electric shock.

- b) **Avoid body contact with earthed or grounded surfaces such as pipes, radiators, ranges and refrigerators.** There is an increased risk of electric shock if your body is earthed or grounded.
  - c) **Do not expose power tools to rain or wet conditions.** Water entering a power tool will increase the risk of electric shock.
  - d) **Do not abuse the cord. Never use the cord for carrying, pulling or unplugging the power tool. Keep cord away from heat, oil, sharp edges or moving parts.** Damaged or entangled cords increase the risk of electric shock.
  - e) **When operating a power tool outdoors, use an extension cord suitable for outdoor use.** Use of a cord suitable for outdoor use reduces the risk of electric shock.
  - f) **If operating a power tool in damp location is unavoidable, use a ground fault circuit interrupter (GFCI) protected supply.** Use of a GFCI reduces the risk of electric shock.
- ### 3) PERSONAL SAFETY
- a) **Stay alert, watch what you are doing and use common sense when operating a power tool. Do not use a power tool while you are tired or under the influence of drugs, alcohol or medication.** A moment of inattention while operating power tools may result in serious personal injury.
  - b) **Use personal protective equipment. Always wear eye protection.** Protective equipment such as dust mask, nonskid safety shoes, hard hat, or hearing

protection used for appropriate conditions will reduce personal injuries.

- c) **Prevent unintentional starting.** Ensure the switch is in the off position before connecting to power source and/ or battery pack, picking up or carrying the tool. Carrying power tools with your finger on the switch or energizing power tools that have the switch on invites accidents.
- d) **Remove any adjusting key or wrench before turning the power tool on.** A wrench or a key left attached to a rotating part of the power tool may result in personal injury.
- e) **Do not overreach. Keep proper footing and balance at all times.** This enables better control of the power tool in unexpected situations.
- f) **Dress properly. Do not wear loose clothing or jewelry. Keep your hair, clothing and gloves away from moving parts.** Loose clothes, jewelry or long hair can be caught in moving parts.
- g) **If devices are provided for the connection of dust extraction and collection facilities, ensure these are connected and properly used.** Use of dust collection can reduce dust-related hazards.

#### 4) POWER TOOL USE AND CARE

- a) **Do not force the power tool. Use the correct power tool for your application.** The correct power tool will do the job better and safer at the rate for which it was designed.
- b) **Do not use the power tool if the switch does not turn it on and off.** Any power tool that cannot be controlled with the switch is dangerous and must be repaired.
- c) **Disconnect the plug from the power source and/or the battery pack from the power tool before making any adjustments, changing accessories, or storing power tools.** Such preventive safety measures reduce the risk of starting the power tool accidentally.
- d) **Store idle power tools out of the reach of children and do not allow persons unfamiliar with the power tool or these instructions to operate the power tool.** Power tools are dangerous in the hands of untrained users.
- e) **Maintain power tools. Check**

**for misalignment or binding of moving parts, breakage of parts and any other condition that may affect the power tool's operation. If damaged, have the power tool repaired before use.** Many accidents are caused by poorly maintained power tools.

- f) **Keep cutting tools sharp and clean.** Properly maintained cutting tools with sharp cutting edges are less likely to bind and are easier to control.
  - g) **Use the power tool, accessories and tool bits, etc. in accordance with these instructions, taking into account the working conditions and the work to be performed.** Use of the power tool for operations different from those intended could result in a hazardous situation.
- #### 5) SERVICE
- a) **Have your power tool serviced by a qualified repair person using only identical replacement parts.** This will ensure that the safety of the power tool is maintained.

## ADDITIONAL SAFETY RULES FOR MITER SAWS

**⚠ WARNING** Do not allow familiarity (gained from frequent use of your saw) to replace safety rules. Always remember that a careless fraction of a second is sufficient to inflict severe injury.

- **DO NOT OPERATE THIS MACHINE** until it is completely assembled and installed according to the instructions. A machine incorrectly assembled can cause serious injury.
- **OBTAIN ADVICE** from your supervisor, instructor, or another qualified person if you are not thoroughly familiar with the operation of this machine. Knowledge is safety.
- **STABILITY.** Make sure the miter saw is placed on a secure supporting surface and does not slip or move during use.
- **FOLLOW ALL WIRING CODES** and recommended electrical connections to prevent shock or electrocution. Protect electric supply line with at least a 15 ampere time-delay fuse or a circuit breaker.
- **MAKE CERTAIN** the blade rotates in the correct direction. The teeth on the blade should point in the direction of rotation as marked on the saw.

- **TIGHTEN ALL CLAMP HANDLES**, knobs and levers prior to operation. Loose clamps can cause parts or the workpiece to be thrown at high speeds.
- **BE SURE** all blade and blade clamps are clean, recessed sides of blade clamps are against blade and arbor screw is tightened securely. Loose or improper blade clamping may result in damage to the saw and possible personal injury.
- **ALWAYS USE A SHARP BLADE.** Check the blade to see if it runs true and is free from vibration. A dull or a vibrating blade can cause damage to the machine and/or serious injury.
- **DO NOT OPERATE ON ANYTHING OTHER THAN THE DESIGNATED VOLTAGE** for the saw. Overheating, damage to the tool and personal injury may occur.
- **DO NOT WEDGE ANYTHING AGAINST THE FAN** to hold the motor shaft. Damage to tool and possible personal injury may occur.
- **DO NOT FORCE CUTTING ACTION.** Stalling or partial stalling of motor can cause damage to the machine or blade and/or serious injury.
- **ALLOW THE MOTOR TO COME TO FULL SPEED** prior to starting cut. Starting the cut too soon may cause damage to the machine or blade and/or serious injury.
- **NEVER CUT METALS** or masonry. Either of these can cause the carbide tips to fly off the blade at high speeds causing serious injury.
- **DO NOT USE ABRASIVE WHEELS.** The excessive heat and abrasive particles generated by them may damage the saw and cause personal injury.
- **NEVER HAVE ANY PART OF YOUR BODY IN LINE WITH THE PATH OF THE SAW BLADE.** Personal injury will occur.
- **NEVER APPLY BLADE LUBRICANT TO A RUNNING BLADE.** Applying lubricant could cause your hand to move into the blade resulting in serious injury.
- **DO NOT** place either hand in the blade area when the saw is connected to the power source. Inadvertent blade activation may result in serious injury.
- **DO NOT PERFORM FREEHAND OPERATIONS** (workpiece not supported by table and fence). Hold the work firmly against the fence and table. Freehand operations on a miter saw could cause the workpiece to be thrown at high speeds, causing serious injury.
- **NEVER REACH AROUND OR BEHIND THE SAW BLADE.** A blade can cause serious injury.
- **DO NOT REACH UNDERNEATH THE SAW** unless it is unplugged and turned off. Contact with saw blade may cause personal injury.
- **SECURE THE MACHINE TO A STABLE SUPPORTING SURFACE.** Vibration can possibly cause the machine to slide, walk, or tip over, causing serious injury.
- **USE ONLY CROSSCUT SAW BLADES** recommended for miter saws. For best results, do not use carbide tipped blades with hook angles in excess of 7 degrees. Do not use blades with deep gullets. These can deflect and contact the guard, and can cause damage to the machine and/or serious injury.
- **USE ONLY BLADES OF THE CORRECT SIZE AND TYPE** specified for this tool to prevent damage to the machine and/or serious injury.
- **INSPECT BLADE FOR CRACKS** or other damage prior to operation. A cracked or damaged blade can come apart and pieces can be thrown at high speeds, causing serious injury. Replace cracked or damaged blades immediately.
- **CLEAN THE BLADE AND BLADE CLAMPS** prior to operation. Cleaning the blade and blade clamps allows you to check for any damage to the blade or blade clamps. A cracked or damaged blade or blade clamp can come apart and pieces can be thrown at high speeds, causing serious injury.
- **DO NOT** use lubricants or cleaners (particularly spray or aerosol) in the vicinity of the plastic guard. The plastic material used in the guard is subject to attack by certain chemicals.
- **ALWAYS USE THE KERF PLATE AND REPLACE THIS PLATE WHEN DAMAGED.** Small chip accumulation under the saw may interfere with the saw blade or may cause instability of workpiece when cutting.
- **USE ONLY BLADE CLAMPS SPECIFIED FOR THIS TOOL** to prevent damage to the machine and/or serious injury.
- **CLEAN THE MOTOR AIR SLOTS** of chips and sawdust. Clogged motor air slots can cause the machine to overheat, damaging the machine and

possibly causing a short which could cause serious injury.

- **KEEP ARMS, HANDS, AND FINGERS AWAY FROM THE BLADE** to prevent severe cuts. Clamp all workpieces that would cause your hand to be within 6" (152 mm) of the saw blade.
- **NEVER LOCK THE SWITCH IN THE "ON" POSITION.** Severe personal injury may result.
- **TURN OFF THE MACHINE** and allow the blade to come to a complete stop before raising the arm and prior to cleaning the blade area, removing debris in the path of the blade, before servicing or adjusting tool. A moving blade can cause serious injury.
- **PROPERLY SUPPORT LONG OR WIDE WORKPIECES.** Loss of control of the workpiece can cause injury.
- **NEVER CROSS ARMS IN FRONT OF BLADE** while using tool. Always make a dry run (unpowered) before making a finish cut so that you can check the path of the blade or severe personal injury may result.
- **ADDITIONAL INFORMATION** regarding the safe and proper operation of power tools (i.e., a safety video) is available from the Power Tool Institute, 1300 Sumner Avenue, Cleveland, OH 44115-2851 ([www.powertoolinstitute.com](http://www.powertoolinstitute.com)). Information is also available from the National Safety Council, 1121 Spring Lake Drive, Itasca, IL 60143-3201. Please refer to the American National Standards Institute ANSI 01.1 Safety Requirements for Woodworking Machines and the U.S. Department of Labor OSHA 1910.213 Regulations.

**▲ WARNING** Do not connect unit to electrical power source until complete instructions are read and understood.

**▲ WARNING** Always wear proper personal hearing protection that conforms to ANSI S12.6 (S3.19) during use. Under some conditions and duration of use, noise from this product may contribute to hearing loss.

**▲ WARNING** NEVER MAKE ANY CUT UNLESS THE MATERIAL IS SECURED ON THE TABLE AND AGAINST THE FENCE.

**▲ WARNING** Some dust created by power sanding, sawing, grinding, drilling, and other construction activities contains chemicals known to the State of California to cause cancer, birth defects or other reproductive harm. Some examples of these chemicals are:

- lead from lead-based paints,
- crystalline silica from bricks and cement and other masonry products, and
- arsenic and chromium from chemically-treated lumber.

Your risk from these exposures varies, depending on how often you do this type of work. To reduce your exposure to these chemicals: work in a well ventilated area, and work with approved safety equipment, such as those dust masks that are specially designed to filter out microscopic particles.

- **Avoid prolonged contact with dust from power sanding, sawing, grinding, drilling, and other construction activities. Wear protective clothing and wash exposed areas with soap and water.** Allowing dust to get into your mouth, eyes, or lay on the skin may promote absorption of harmful chemicals.

**▲ WARNING** Use of this tool can generate and/or disperse dust, which may cause serious and permanent respiratory or other injury. Always use NIOSH/OSHA approved respiratory protection appropriate for the dust exposure. Direct particles away from face and body.

- **Wear appropriate hearing protection during use.** Under some conditions and duration of use, noise from this product may contribute to hearing loss.

**▲ WARNING** ALWAYS use safety glasses. Everyday eye glasses are NOT safety glasses. Also use face or dust mask if cutting operation is dusty. ALWAYS WEAR CERTIFIED SAFETY EQUIPMENT:

- ANSI Z87.1 eye protection (CAN/CPA Z94.3),
- ANSI S12.6 (S3.19) hearing protection,
- NIOSH/OSHA respiratory protection.

# ELECTRICAL REQUIREMENTS AND SAFETY

## POWER SUPPLY AND MOTOR SPECIFICATIONS

The AC motor used in this saw is a universal, nonreversible type.

**⚠ WARNING** To avoid electrical hazards, fire hazards, or damage to the tool, use proper circuit protection. Your saw is wired at the factory for 120 V operation. Connect to a 120 V, 9 A circuit and use a 9 A time delay fuse or circuit breaker. To avoid shock or fire, if power cord is worn or cut, or damaged in any way, have it replaced immediately.

## ELECTRICAL REQUIREMENTS - DOUBLE INSULATED

The power tool is double insulated to provide a double thickness of insulation between you and tool's electrical system. All exposed metal parts are isolated from the internal metal motor components with protecting insulation.

**Replacement parts** – When servicing, use only identical replacement parts.

**Polarized plugs** – This saw has a plug that looks like the one shown below:

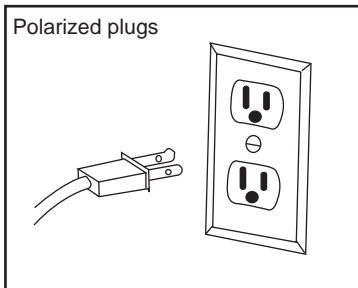

To reduce the risk of electrical shock, this saw has a polarized plug (one blade is wider than the other). This plug will fit in a polarized outlet only one way. If the plug does not fit fully in the outlet, reverse the plug. If it still does not fit, contact a qualified electrician to install the proper outlet. Do not change the plug in any way.

**⚠ WARNING** Double insulation does not take the place of normal safety precautions when operating this tool.

To avoid electrocution:

- Use only identical replacement parts when servicing a tool with double insulation. Servicing should be performed by a qualified technician.
- Do not use power tools in wet or damp locations or expose them to rain or snow.

## MOTOR SAFETY PROTECTION IMPORTANT:

To avoid motor damage, the motor should be blown out or vacuumed frequently to keep sawdust from interfering with the motor ventilation.

- **Connect** this saw to a 120 V, 9 A circuit with a 9 A time-delay fuse or circuit breaker. Using the wrong size fuse can damage the motor.
- If the motor will not start, release the trigger switch immediately. **UNPLUG THE SAW.** Check the saw blade to make sure it turns freely. If the blade is free, try to start the saw again. If the motor still does not start, refer to the **TROUBLESHOOTING GUIDE.**
- If the tool suddenly stalls while cutting wood, release the trigger switch, unplug the tool and free the blade from the wood. The saw may now be started and the cut finished.
- **FUSES** may "blow" or circuit breakers may trip frequently if:
  - **MOTOR** is overloaded – overloading can occur if you feed too rapidly or make too many start/stops in a short time.
  - **LINE VOLTAGE** is more than 10% above or below the nameplate voltage rating. For heavy loads, the voltage at motor terminals must equal the voltage specified on the nameplate.
  - **IMPROPER** or dull saw blades are used.

- Most motor troubles may be traced to loose or incorrect connections, overload, low voltage or inadequate power supply wiring. Always check the connections, the load and supply circuit if the motor doesn't run well. Check minimum gauge for the length of cord you are using on the chart below.

### GUIDELINES FOR EXTENSION CORDS

**Use a proper extension cord.** Make sure your extension cord is in good condition. When using an extension cord, be sure to use one heavy enough to carry the current your product will draw. An undersized cord will cause a drop in line voltage, resulting in loss of power and overheating. The table below shows the correct size to use depending on cord length and nameplate ampere rating. If in doubt, use the next heavier gauge. The smaller the gauge number, the heavier the cord.

**Be sure your extension cord is properly wired** and in good condition. Always replace a damaged extension cord or have it repaired by a qualified person before using it. Protect your extension cords from sharp objects, excessive heat and damp or wet areas.

**Use a separate electrical circuit for your tools.** This circuit must not be less than a #18 wire with a 9 A time lag fuse.

**NOTE:** When using an extension cord on a circuit with a #18 wire, the extension cord must not exceed 25 feet in length. Before connecting the tool to the power line, make sure the switch is in the OFF position and the electric current is rated the same as the current stamped on the motor nameplate, running at a lower voltage will damage the motor.

MINIMUM GAUGE FOR EXTENSION CORDS (AWG)				
(When using 120 volts only)				
Ampere Rating		Total length of Cord		
More Than	Not More Than	25ft.	50ft.	100ft. 150ft.
0	6	18	16	16 14
6	10	18	16	14 12
10	12	16	16	14 12
12	16	14	12	Not Recommended

**⚠ CAUTION** In all cases make certain the receptacle in question is properly grounded. If you are not sure, have a certified electrician check the receptacle.

### GLOSSARY OF TERMS

**AMPERAGE (AMPS)** – A measure of the flow of electric current. Higher ratings generally means the tool is suited for heavier use.

**ARBOR LOCK** – Allows the user to keep the blade from rotating while tightening or loosening the arbor bolt during blade replacement or removal.

**BASE** – Supports the table, holds accessories and allows for workbench or leg set mounting.

**BEVEL LOCK HANDLE** – Locks the miter saw at a desired bevel angle.

**BEVEL SCALE** – To measure the bevel angle of the saw blade 0° to 45° left.

**CARBIDE TIPPED** – Extremely hard steel pieces with sharp cutting edges fastened to cutting tools such as saw blades.

**COVER PLATE SCREW** – Loosen this screw and rotate the plate for access to the blade arbor bolt.

**DOUBLE-INSULATED** – A form of electrical protection featuring two separate insulation systems to help protect against electrical shock.

**EXTENSION CORD** – An electric cord used between power tools and outlets to extend the range of the tools. The more amperage your tool uses, the longer the distance, the larger the size of the wire needed in your extension cord.

**EYE PROTECTION** – Goggles or spectacles intended to protect your eyes. Eye protection should meet the requirements of ANSI Z.87.1 (USA) or CSA Z94.3-M88 (Canada).

**FACE SHIELD** – An impact resistant shield that helps to protect your face from chips, sparks, small debris. Should only be used in conjunction with additional eye protection.

**FENCE** – Helps to keep the workpiece from moving when sawing. Scaled to assist with accurate cutting.

**GUARD** – Protective device that forms a barrier between a hazardous object such as a blade, wheel or cutter and the operator.

**HOLD-DOWN LATCH** – Locks the miter saw in the lowered position for compact storage and transportation.

**INSTRUCTION MANUAL** – Booklet accompanying your power tool that describes the hazards and safe operation procedures, outlines basic tool operation, care and maintenance.

**MITER HANDLE** – Used to rotate the table, and to rotate the saw to a right or left cutting position.

**MITER SCALE** – Measures the miter angle of the saw blade. Positive stop index points have been provided at 0°, 15°, 22.5°, 31.6° and 45° right and left.

**MOUNTING HOLES** – To mount the miter saw to a stable surface.

**ON/OFF TRIGGER SWITCH** – To start the tool, squeeze the trigger. Release the trigger to turn off the miter saw.

**POSITIVE STOP LOCKING LEVER** – Locks the miter saw at a preset positive stop for the desired miter angle.

**SWITCH HANDLE** – The switch handle contains the trigger switch and the laser on/off switch. The blade is lowered into the workpiece by pushing down on the handle. The saw will return to its upright position when the handle is released.

**WARNING LABELS** – Read and understand for your own safety. Make sure all labels are present on machine and legible.

**BLADE WRENCH STORAGE** – Convenient storage to prevent misplacing the blade wrench.

## **WOODWORKING TERMS**

**ARBOR** – The shaft on which a blade is mounted.

**BEVEL CUT** – An angle cut made through the face of the workpiece.

**COMPOUND CUT** – An angled cut to both the edge and face of a board, most common use is with crown molding.

**CROSS CUT** – A cut which runs across the board perpendicular to the grain.

**FREEHAND** – Performing a cut without using a fence (guide), hold down or other proper device to prevent the workpiece from twisting during the cutting operation.

**HEEL** – Misalignment of the blade.

**KERF** – The width of a saw cut, determined by the thickness and set of the blade.

**KICKBACK** – sudden and unintended movement of the tool or workpiece. It is typically caused by binding or pinching of the workpiece.

**MITER CUT** – A miter is a type of joint where the two parts to be joined are cut at an angle, and typically the finished joint forms a 90-degree angle. Also commonly spelled “mitre”.

**REVOLUTIONS PER MINUTE (RPM)** – The number of turns completed by a spinning object in one minute.

**SAW BLADE PATH** – The area of the workpiece or table top directly in line with the travel of the blade or the part of the workpiece which will be cut.

**SET** – The distance between two saw blade tips, bent outward in opposite directions to each other. The further apart the tips are, the greater the set.

**THIN-KERF BLADE** – Thinner than normal blades, remove less material, smaller kerfs (between 0.065 in. and 0.070 in.). Blade thinness also may increase the heat generated while cutting.

**WORKPIECE** – The wood being cut. The surfaces of a workpiece are commonly referred to as faces, ends and edges.

## SYMBOLS

Your power tool and its Instruction Manual may contain "WARNING ICONS" (a picture symbol intended to alert you to, and/or instruct you how to avoid a potentially hazardous condition). Understanding and heeding these symbols will help you operate your tool better and safer. Shown below are some of the symbols you may see.



**SAFETY ALERT:** Precautions that involve your safety.



**PROHIBITION**



**WEAR EYE PROTECTION:** Always wear safety goggles or safety glasses with side shields.



**WEAR A MASK:** Always wear a face mask or dust mask.



**WEAR HEARING PROTECTION:** To reduce the risk of induced hearing loss, always wear a hearing protection.



**READ AND UNDERSTAND INSTRUCTION MANUAL:** To reduce the risk of injury, user and all bystanders must read and understand Instruction manual before using this product.



**KEEP HANDS AWAY FROM BLADE:** Failure to keep your hands away from the blade will result in serious personal injury.



**SUPPORT AND CLAMP WORK**

## CARTON CONTENTS

- 1) Carefully remove the miter saw from the carton.
- 2) Separate and layout all of the parts. Carefully check them according to the diagram below.

**⚠ WARNING** If any part is missing or damaged, please do not plug in or use the miter saw until replacements have been obtained.

## UNPACKING YOUR MITER SAW

1. Miter saw
2. Hold-down clamp
3. Dust bag
4. Blade wrench

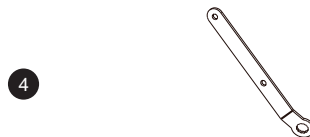
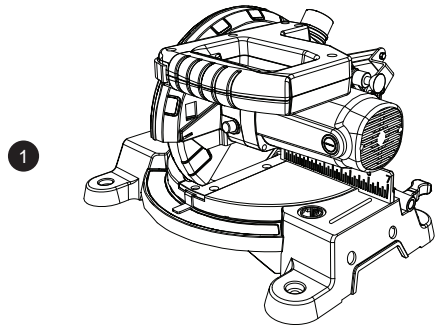

# FUNCTIONAL DESCRIPTION

1. Upper blade guard
2. Safety lock-off button
3. Switch handle
4. Motor
5. Lower blade guard
6. Fence
7. Miter scale
8. Table insert
9. Mounting hole
10. Base
11. Rear support bracket
12. Bevel lock handle
13. Dust bag
14. ON/OFF trigger switch
15. Hold-down latch
16. Bevel scale
17. Miter table locking lever
18. Hand hold for transportation
19. Turn table
20. Hold-down clamp
21. Arbor lock button

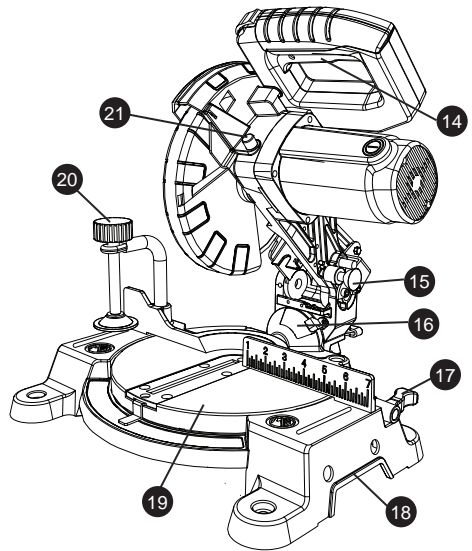
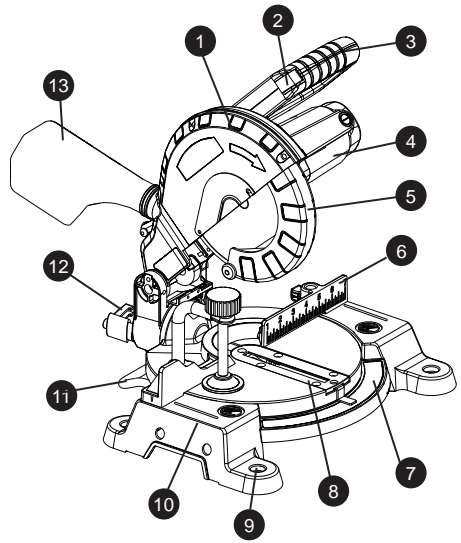

## TOOLS NEEDED FOR ASSEMBLY

### Supplied



Blade wrench

### Not Supplied



Philips screwdriver



Adjustable Wrench

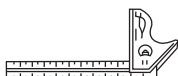

Combination Square



3 mm hex key

## ASSEMBLY AND ADJUSTMENTS

### **⚠ WARNING**

- To avoid injury, do not connect this miter saw to the power source until it is completely assembled and adjusted, and you have read and understood this Instruction Manual.
- To reduce the risk of injury, turn unit off and disconnect it from power source before installing and removing accessories, before adjusting or when making repairs. An accidental start-up can cause injury.

### TRANSPORTING THE SAW (FIGURE A)

### **⚠ WARNING**

- To reduce the risk of injury, turn unit off and disconnect it from power source before installing and removing accessories, before adjusting or when making repairs. An accidental start-up can cause injury.
- To reduce the risk of serious personal injury, ALWAYS lock the miter table locking lever, bevel lock handle, and hold-down latch before transporting saw.
- In order to conveniently carry the miter saw from place to place, use the hand holds in the base (1).

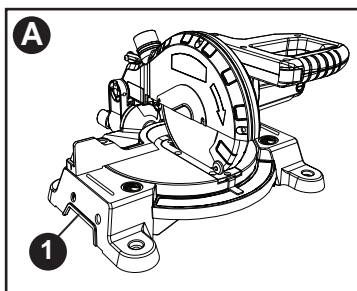

### RELEASING THE CUTTING HEAD (FIGURE B)

### **⚠ WARNING**

- To avoid injury and damage to the saw, transport or store the miter saw with the cutting head locked in the down position. Never use the hold-down latch to hold the cutting head in a down position for cutting operations.

## Unlocking

- Push down slightly on the switch handle (1).
- Pull out the hold-down latch (2).
- Allow the cutting head to rise to the uppermost position.

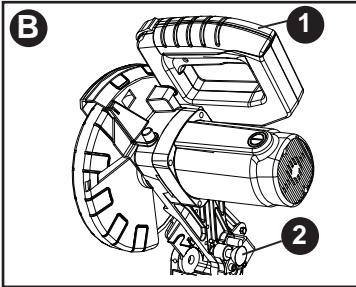

## Locking

**⚠ WARNING** The hold-down latch should be used **ONLY** when carrying or storing the saw. **NEVER** use the hold-down latch for any cutting operation.

When transporting or storing the miter saw, the cutting head should always be locked in the down position.

- Push the cutting head down to its lowest position.
- Push the hold-down latch (2) into the locking hole.

**IMPORTANT:** To avoid damage, never carry the miter saw by the switch handle, the cutting arm. Only lift machine by the base hand holds.

**⚠ WARNING** To reduce the risk of injury, turn unit off and disconnect it from power source before installing and removing accessories, before adjusting or when making repairs. An accidental start-up can cause injury. **NOTE:** Your miter saw was adjusted at the factory. However, during shipment slight misalignment may have occurred. Check the following settings and adjust if necessary prior to using this miter saw.

## INSTALLING THE DUST BAG (FIGURE C)

- Squeeze the metal collar wings (1) of the dust bag (2).
- Place the dust bag neck opening around the exhaust port (3), and release the metal collar wings.

**NOTE:** To empty the dust bag, squeeze the metal collar and remove from exhaust port. Open zipper on underside of bag and empty into waste container.

**IMPORTANT:** Check frequently and empty bag before it gets full.

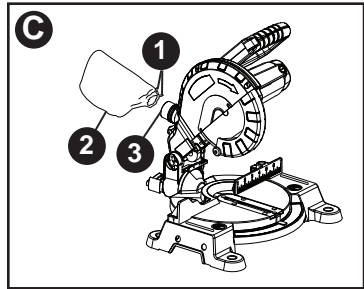

## POSITIONING THE REAR SUPPORT BRACKET PRIOR TO USE (FIGURE D)

**⚠ WARNING** The rear support bracket must be extended out prior to using the miter saw. Please follow the below instructions before using the saw.

- The rear support bracket (1) has been pre-installed at the factory. Prior to any use, pull on the end of the bracket to extend out to its full position.

**NOTE:** Make sure the angle of stay is in the down position (as shown in Figure D) for maximum support.

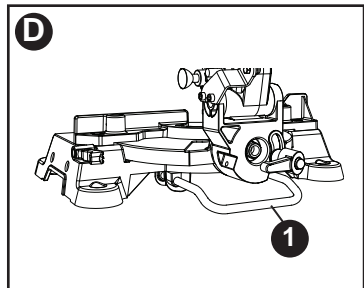

## INSTALLING THE HOLD-DOWN CLAMP (FIGURE E, F)

- Place the hold-down clamp (1) in one of the mounting holes (2).

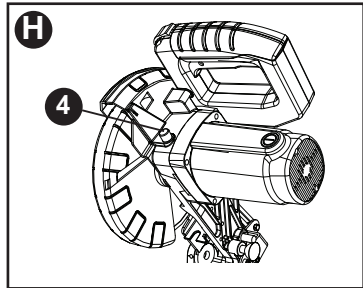
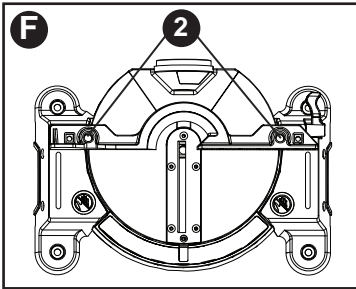
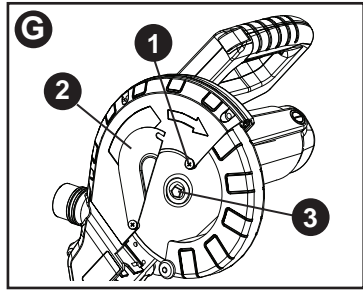
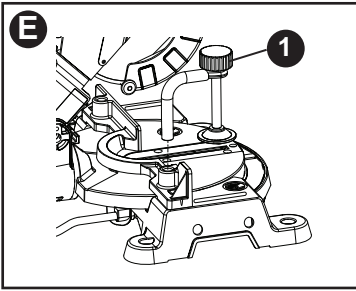

- Locate the arbor lock button (4) below the trigger switch handle. **(Figure H)**

- Press the arbor lock button (4-**Figure H**), holding it in firmly while turning the blade clockwise. The arbor lock button will then engage and lock the arbor. Continue to hold the arbor lock button, while placing the blade end wrench over the arbor bolt (3) and turning the wrench clockwise (left-hand threads) to loosen the arbor bolt. **(Figure I)**

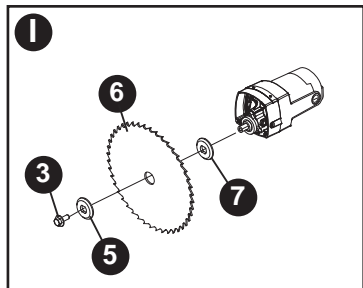

## REMOVING AND INSTALLING THE BLADE

### Removing Blade (Figure G, H, I)

#### **⚠ WARNING**

- To avoid injury from an accidental start, make sure the switch is in the OFF position and plug is not connected to the power source outlet.
- Only use a 7-1/4 inch diameter blade with a 5/8 inch round arbor hole, and no more that 7 degree hook angle.
- NEVER cut metals or masonry products with this tool. This miter saw is designed for use on wood and wood-like products only.
- Never depress the arbor lock button while the blade is under power or coasting.
- Unplug the saw from the outlet.
- Raise the miter saw to the upright position.
- Loosen the cover plate screw (1) with a Phillips screwdriver. **(Figure G)**
- Rotate the cover plate (2) to expose the arbor bolt (3).

- Raise up the lower blade guard and hold it while removing the arbor bolt (3), outer blade collar (5), and the blade (6). **DO NOT REMOVE THE INNER BLADE COLLAR (7).**

**NOTE:** Pay attention to the pieces removed, noting their position and direction they face. Wipe the blade collars clean of any sawdust before installing the new blade.

### Installing Blade (Figure G, H, I)

**▲ WARNING** Unplug the miter saw before changing/installing the blade.

- Install a 7-1/4 in. blade with a 5/8 in. arbor and no more than 7 degree hook angle, making sure the rotation arrow on the blade matches the clockwise rotation arrow on the upper guard, and the blade teeth are pointing downward.
- Raise up the lower blade guard and hold it while placing the outer blade collar (5) against the blade and on the arbor. Thread the arbor bolt (3) into the arbor in a counterclockwise direction. **(Figure I)**  
**IMPORTANT:** Make sure the flats of the blade collars are engaged with the flats on the arbor shaft. Also, the flat side of the arbor collar must be placed against the blade.
- Place the blade wrench on the arbor bolt.
- Press the arbor lock button (4-**Figure H**), holding it in firmly while turning the blade counterclockwise. When it engages, continue to press the arbor lock button in, while tightening the arbor bolt (3) securely (left hand threads). **(Figure G)**
- Rotate the cover plate (2) back to its original position until the slot in the cover plate engages with the cover plate screw (1). Tighten the screw with a Phillips screwdriver.
- Verify the operation of the guard. Make sure it does not bind or stick.
- Be sure the arbor lock button (4) is released so the blade turns freely by spinning the blade until the arbor lock disengages. **(Figure H)**

### **▲ WARNING**

- To avoid injury, never use the saw without the cover plate secure in place. It keeps the arbor bolt from falling out if it accidentally loosens, and helps prevent the spinning blade from coming off the saw. It also keeps the guard from contacting a spinning blade.
- Make sure the collars are clean and properly arranged. Lower the blade into the table and check for any contact with the metal base or the turn table.

### MOUNTING THE MITER SAW (FIGURE J, K)

**▲ WARNING** To avoid injury from unexpected saw movement:

- Before moving the saw, disconnect the power cord from the outlet, and lock the cutting arm in the lower position using the hold-down latch. **NOTE:** The hold-down latch is for carrying or storing the tool. It is not to be used for holding the saw while cutting. Lower blade and press in hold-down latch to secure saw for transportation or storage.
- Never carry the miter saw by the power cord or by the switch handle. Carrying the tool by the power cord could cause damage to the insulation or wire connections resulting in electric shock or fire.
- To avoid injury from flying debris, do not allow visitors to stand behind the saw.
- Place the saw on a firm, level work surface where there is room for handling and properly supporting the workpiece.
- Support the saw on a level work surface.
- Always bolt or clamp the saw to its support.
- To prevent binding and inaccuracy, be sure the mounting surface is not warped or otherwise uneven. If the saw rocks on the surface, place a thin piece of material under one saw foot until the saw sits firmly on the mounting surface.

## Mounting Instructions

- **For stationary use**, place the saw in the desired location, directly on a workbench where there is room for handling and proper support of the workpiece. The base of the saw has four mounting holes. Bolt the base of the miter saw (1) to the work surface (5), using the fastening method as shown in **Figure J**.

1. Miter saw base
2. Hex head bolt
3. Rubber washer
4. Flat washer
5. Workbench
6. Flat washer
7. Lockwasher
8. Hex nut
9. Jam nut

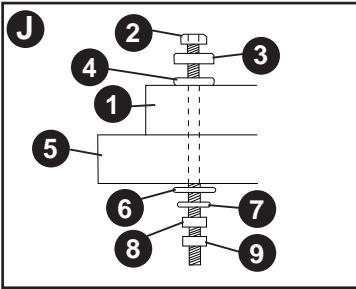

**NOTE:** Mounting hardware is not included with this tool. Bolts, nuts, washers, & screws must be purchased separately.

- **For portable use**, place the saw on a 3/4 in. thick piece of plywood. Bolt the base of the miter saw securely to the plywood using the mounting holes on the base. Use C-clamps to clamp this mounting board to a stable work surface at the worksite. (**Figure K**)

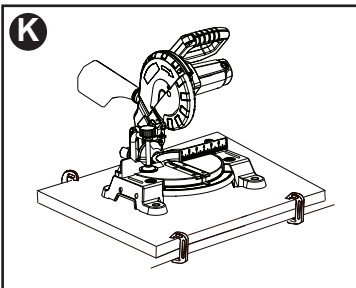

**NOTE:** If a miter saw stand is used, please follow all instructions shown in that product's instructions for proper mounting.

## BEVEL STOP ADJUSTMENTS (FIGURE L, M, N)

**▲ WARNING** To avoid injury from unexpected starting or electrical shock, make sure the trigger is released and remove the power cord from the power source.

### 90°(0°) Bevel Adjustment (Figure L)

- Set the miter angle to zero degrees. Loosen bevel lock handle (1) and tilt the cutting arm completely to the right. Tighten the bevel lock handle.
- Lower and lock the cutting head. Place a combination square (2) on the miter table with the ruler against the table and the heel of the square against the saw blade.
- If the blade is not 90°(0°) square with the table, loosen the bevel lock handle (1), tilt the cutting head to the left, loosen the locknut (3) with a 10 mm wrench. Then, adjust the set screw in the locknut (3) clockwise or counterclockwise with a 3 mm hex key.  
**NOTE:** The locknut is at the right rear side of the saw base.
- Tilt the cutting arm back to the right at 90°(0°) bevel and recheck for alignment.
- Repeat above steps if further adjustment is needed.
- Tighten locknut (3) and bevel lock handle (1) when alignment is achieved.

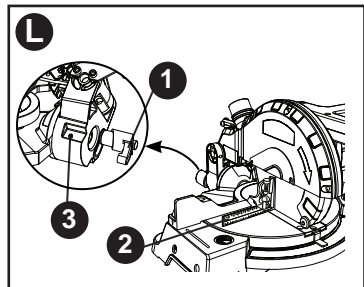

### 90° Bevel Pointer Adjustment (Figure M)

- When the blade is exactly 90° (0°) to the table, loosen the bevel pointer screw (4) using a Phillips screwdriver.
- Adjust bevel pointer (5) to the “0” mark on the bevel scale and retighten the screw.

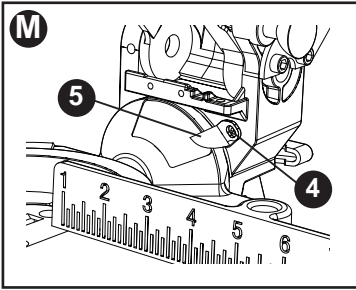

### 45° Bevel Adjustment (Figure N)

- Set the miter angle to zero degrees. Loosen the bevel lock handle (1) and tilt the cutting head completely to the left.
  - Lower and lock the cutting head. Using a combination square, check to see if the blade angle is 45° to the table.
  - If the blade is not at 45° bevel to the table, tilt the cutting arm to the right, loosen the locknut (5) with a 10 mm wrench. Then, adjust the set screw in the locknut (5) clockwise or counterclockwise with a 3 mm hex key.
- NOTE:** The locknut is at the left rear side of the saw base.
- Tilt the cutting arm to the left to 45° bevel and recheck for alignment.
  - Repeat above steps until the blade is at 45° to the table.
  - Tighten bevel lock handle (1) and locknut (5) when alignment is achieved.

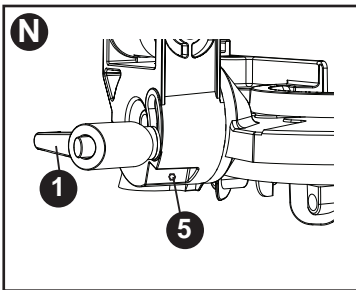

### MITER ANGLE ADJUSTMENT (FIGURE O)

The miter scale assists the user in setting the desired miter angles from 45° left to 45° right. The miter saw table has nine of the most common angle settings with positive stops at 0°, 15°, 22.5°, 31.6°, and 45°. These positive stops position the blade at the desired angle quickly and accurately.

- Lock the cutting head in the down position by pushing the hold-down latch (1) in the locking hole.
- Raise the miter table locking lever (2) to loosen the turn table.
- Hold the base of the saw arm (3) firmly and use it to rotate the miter table while holding the saw base steady.
- You can quickly locate the miter angle by the stops or clicks.
- Once you set the miter angle you want, tighten the miter table locking lever (2) by pushing it down.

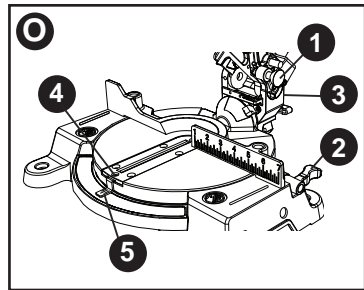

### MITER ANGLE POINTER ADJUSTMENT (FIGURE O)

- Move the table to the 0° positive stop.
- Loosen the screw (4) that holds the pointer (5) with a Phillips screwdriver.
- Adjust the pointer (5) to the 0° mark and retighten screw (4).

### ADJUSTING FENCE SQUARENESS (FIGURE P)

- Set the bevel and miter angles to 0°.
- Lower the cutting arm and lock in position.
- Using a square (1), lay the heel of the square against the blade and the ruler against the fence (2) as shown.

- If the blade is not 90° to the fence, loosen the two fence locking bolts (3) by 6 mm hex wrench.
- Adjust the fence 90° to the blade and tighten the two fence locking bolts.

**⚠ CAUTION** If the saw has not been used recently, recheck blade squareness to the fence and readjust if needed.

- After fence has been aligned, using a scrap piece of wood, make a cut at 90°, then check squareness on the piece. Readjust if necessary.

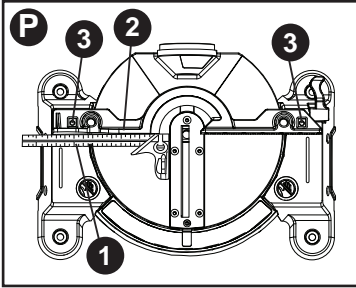

### ADJUSTING CUTTING DEPTH (FIGURE Q)

The maximum depth travel of the cutting head was set at the factory. Check to see that the blade does not extend more than 1/4 in. below the table insert, and does not touch the control arm throat or any part of the base or table. If the maximum depth needs readjusting:

- To adjust the cutting depth, loosen the lock nut (1) and the bolt (2) by two 8 mm wrenches.
- Turn the adjustment bolt (2) out (counterclockwise) to decrease the cutting depth or in (clockwise) to increase the cutting depth.
- Carefully rotate the blade manually to check for contact. Avoid touching blade points or edges.
- Repeat until adjusted properly, and tighten the locknut (1) to secure the adjustment bolt (2) into position.

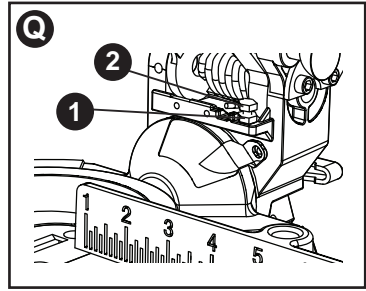

## OPERATING INSTRUCTIONS BEFORE USING THE MITER SAW

### ⚠ WARNING

- To reduce the risk of injury, turn unit off and disconnect it from power source before installing and removing accessories, before adjusting or when making repairs. An accidental start-up can cause injury.
- To avoid mistakes that could cause serious, permanent injury, do not plug the tool in until the following steps are completed:
  - Completely assemble and adjust the saw, following the instructions. **(ASSEMBLY AND ADJUSTMENTS)**
  - Learn the use and function of the ON/OFF switch, upper and lower blade guards, hold-down latch, bevel lock handle and cover plate screws.
  - Review and understand all safety instructions and operating procedures in this Instruction Manual.
  - Review the **MAINTENANCE** and **TROUBLESHOOTING** for your miter saw.
- To avoid injury or possible death from electrical shock, make sure your fingers do not touch the plug's metal prongs when plugging or unplugging your miter saw.

### BEFORE EACH USE INSPECT YOUR SAW

- **Disconnect the miter saw.** To avoid injury from accidental starting, unplug the saw before any adjustments, including set-up and blade changes.

- **Compare the direction of rotation arrow** on the guard to the direction arrow on the blade. The blade teeth should always point downward at the front of the saw.
- **Tighten the arbor bolt.**
- **Tighten the cover plate screw.**
- **Check for damaged parts.** Check for:
  - Alignment of moving parts
  - Damaged electric cords
  - Binding of moving parts
  - Mounting holes
  - Function of arm return spring and lower guard: Push the cutting arm all the way down, then let it rise until it stops. The lower guard should fully close. Follow instructions in **TROUBLESHOOTING** for adjustment if necessary.
  - Other conditions that may affect the way the miter saw works.
- Keep all guards in place, in working order and proper adjustment. If any part of this miter saw is missing, bent, damaged or broken in any way, or any electrical parts do not work, turn the saw off and unplug it.
- Keep all guards in place, in working order and proper adjustment. If any part of this miter saw is missing, bent, damaged or broken in any way, or any electrical parts do not work, turn the saw off and unplug it.
- Replace bent, damaged, missing or defective parts before using the saw again.
- Maintain tools with care. Keep the miter saw clean for best and safest performance. Follow instructions for lubricating. Do not put lubricants on the blade while it is spinning.
- Remove adjusting wrench from the tool before turning it on.
- To avoid injury from jams, slips, or thrown pieces, use only recommended accessories.

## RECOMMENDED ACCESSORIES

- Follow the instructions that come with the accessory. The use of improper accessories may cause risk of injury to persons.

- Choose the correct 7-1/4 in. diameter blade (with a 5/8 inch round arbor hole, and no more than 7 degree hook angle) for the material and the type of cutting you plan to do. Do not use thin kerf blades.
- Make sure the blade is sharp, undamaged and properly aligned. With the saw unplugged, push the cutting arm all the way down. Manually spin the blade and check for clearance. Tilt the power-head to a 45° bevel and repeat the test.
- Make sure the blade and arbor collars are clean.
- Make sure all clamps and locks are tight and there is no excessive play in any parts.

## KEEP YOUR WORK AREA CLEAN

Cluttered areas and benches invite accidents.

**⚠ WARNING** To avoid burns or other fire damage, never use the miter saw near flammable liquids, vapors, or gases.

- Plan ahead to protect your eyes, hands, face and ears.
- Know your miter saw. Read and understand the Instruction Manual and labels affixed to the tool. Learn its application and limitations as well as the specific potential hazards peculiar to this tool. To avoid injury from accidental contact with moving parts, do not do layout, assembly, or setup work on the miter saw while any parts are moving.
- Avoid accidental starting, make sure the trigger switch is disengaged before plugging the miter saw into a power outlet.

## PLAN YOUR WORK

- Use the right tool. Do not force a tool or attachment to do a job it was not designed to do. Use a different tool for any workpiece that can't be held in a solidly braced, fixed position.

**▲ CAUTION** This machine is not designed for cutting masonry, masonry products, metals. Use this miter saw to cut only wood, or wood-like products. Other material may shatter, bind the blade, or create other dangers. Remove all nails that may be in the workpiece to prevent sparking that could cause a fire. Remove dust bag when cutting non-ferrous metals.

### DRESS FOR SAFETY

 Any power tool can throw foreign objects into the eyes. This can result in permanent eye damage. Everyday eyeglasses have only impact resistant lenses and are not safety glasses. Glasses or goggles not in compliance with ANSI Z87.1 could seriously injure you when they break.

- Do not wear loose clothing, gloves, neckties or jewelry (rings, watches). They can get caught and draw you into moving parts.
- Wear non-slip footwear.
- Tie back long hair.
- Roll long sleeves above the elbow.
- Noise levels vary widely. To avoid possible hearing damage, wear ear plugs when using any miter saw.
- For dusty operations, wear a dust mask along with safety goggles.

### INSPECT YOUR WORKPIECE

Make sure there are no nails or foreign objects in the part of the workpiece being cut.

Plan your work to avoid small pieces that may bind, or that are too small to clamp and get a solid grasp on. Plan the way you will grasp the workpiece from start to finish. Avoid awkward operations and hand positions. Keep your hands at least 6 inches away from the blade path.

A sudden slip could cause your fingers or hand to move into the blade.

**▲ WARNING** TO ENSURE THE BLADE PATH IS CLEAR OF OBSTRUCTIONS, ALWAYS MAKE A DRY RUN OF THE CUT WITHOUT POWER BEFORE MAKING ANY CUTS ON THE WORKPIECE.

### DO NOT OVER-REACH

Keep good footing and balance. Keep your face and body to one side, out of the line of a possible kickback. NEVER stand in the line of the blade.

### Never cut freehand:

- Brace your workpiece firmly against the fence and table stop so it will not rock or twist during the cut.
- Make sure there is no debris between the workpiece and the table or fence.
- Make sure there are no gaps between the workpiece, fence and table that will let the workpiece shift after it is cut.
- Keep the cut off piece free to move sideways after it is cut off. Otherwise, it could get wedged against the blade and thrown violently.
- Only the workpiece should be on the saws table.
- Secure work. Use clamps or a vise to help hold the work when it is practical.

### USE EXTRA CAUTION WITH LARGE OR ODD SHAPED WORKPIECES

- Use extra supports (tables, sawhorses, blocks, etc.) for workpieces large enough to tip.
- Never use another person as a substitute for a table extension, or as an additional support for a workpiece that is longer or wider than the basic miter saw table, or to help feed, support, or pull the workpiece.
- Do not use this saw to cut small pieces. If the workpiece being cut would cause your hand or fingers to be within 6 in. of the saw blade the workpiece is too small. Keep hands and fingers out of the “no hands zone” area marked on the saws table.
- When cutting odd shaped workpieces, plan your work so it will not bind in the blade and cause possible injury. Molding, for example, must lie flat or be held by a fixture or jig that will not let it move when cut.

- Properly support round material such as dowel rods, or tubing, which have a tendency to roll when cut, causing the blade to “bite”. This is especially important when making angle cuts.
- NEVER tie, tape or hold the guard open when operating the saw.

**⚠ WARNING** A workpiece that is clamped, balanced and secure before a cut may become unbalanced after a cut is completed. An unbalanced load may tip the saw or anything the saw is attached to, such as a table or workbench. When making a cut that may become unbalanced, properly support the workpiece and ensure the saw is firmly bolted to a stable surface. Personal injury may occur.

**⚠ WARNING** The clamp foot must remain clamped above the base of the saw whenever the clamp is used. Always clamp the workpiece to the base of the saw – not to any other part of the work area. Ensure the clamp foot is not clamped on the edge of the base of the saw.

**⚠ CAUTION** Always use a work clamp to maintain control and reduce the risk of workpiece damage and personal injury.

#### WHEN SAW IS RUNNING

**⚠ WARNING** Do not allow familiarity from frequent use of your miter saw to result in a careless mistake. A careless fraction of a second is enough to cause a severe injury. Before cutting, if the saw makes an unfamiliar noise or vibrates, stop immediately. Turn the saw OFF. Unplug the saw. Do not restart until finding and correcting the problem.

#### BODY AND HAND POSITION (FIGURE R, S, T, U, V)

##### ⚠ WARNING

**⚠** Never place hands near the cutting area. Proper positioning of your body and hands when operating the miter saw will make cutting easier and safer. Keep children away. Keep all visitors at a safe distance from the miter saw. Make sure bystanders are clear of the saw and workpiece. Do not force the saw. It will do the job better and safer at its designed rate.

**ALWAYS MAKE DRY RUNS (UNPOWERED) BEFORE FINISH CUTS SO THAT YOU CAN CHECK THE PATH OF THE BLADE. DO NOT CROSS HANDS, AS SHOWN IN FIGURE R, S, T & U.**

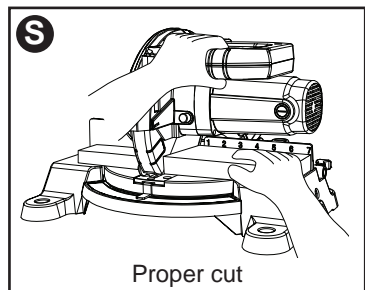
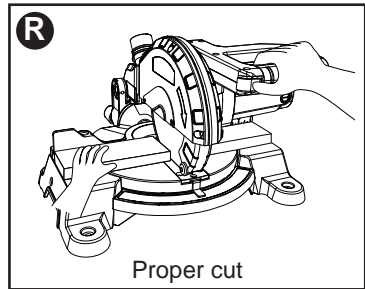

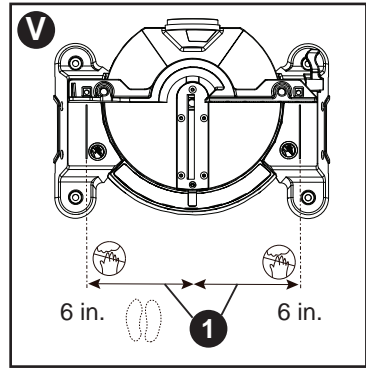
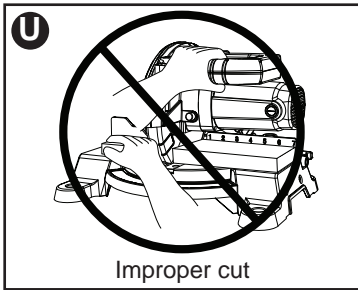
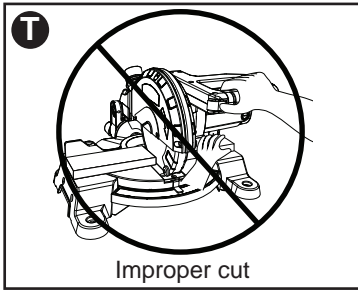

## BASIC SAW OPERATIONS

**⚠ WARNING** Never connect the plug to the power source outlet until all installations and adjustments are completed and you have read and understood the safety and operational instructions.

### Starting a cut:

- Place hands at least 6 in. away on both sides of the blade path - "no-hands zone (1)". (Figure V)
- Hold workpiece firmly against the fence to prevent movement toward the blade.
- With the power switch OFF, bring the saw blade down to the workpiece to see the cutting path of the blade.
- Squeeze trigger switch to start saw.
- Lower blade into workpiece with a firm downward motion.

### Finishing a cut:

- Hold the cutting arm in the down position.
- Release trigger switch and wait for all moving parts to stop before moving your hands and raising the cutting arm.
- Unplug the miter saw.

### Before freeing jammed material:

- Release trigger switch.
- Wait for all moving parts to stop.
- Unplug the miter saw.

### TURNING THE SAW ON (FIGURE W)

- To reduce the likelihood of accidental starting, a thumb activated lock-off switch is located on top of the switch handle. The lock-off switch (1) must be pushed in before the trigger switch (2) can be activated and the miter saw started.

**NOTE:** To make the ON/OFF trigger switch childproof, insert a padlock (not provided) or chain with padlock through the hole (3) in the trigger switch. Lock the tool's switch to prevent children and other unqualified users from turning the machine on.

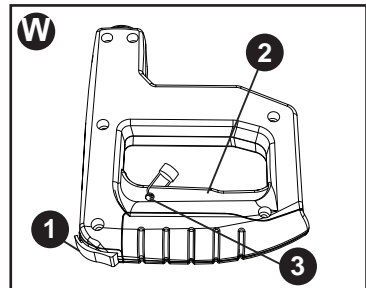

## BEFORE LEAVING THE SAW

- Never leave tool running unattended. Turn power OFF. Wait for all moving parts to stop.
- Make workshop childproof. Lock the shop. Disconnect master switches. Store tool away from children and other unqualified users.

**⚠ WARNING** To avoid injury from materials being thrown, always unplug the saw to avoid accidental starting, and remove small pieces of material from the table cavity.

## MITER CUT (FIGURE X)

- When a miter cut is required, unlock the miter table locking lever (1).
- Hold the base of saw arm to move the table to the desired angle.
- When the table is in the desired position, as shown on the miter scale (2), tighten the miter table locking lever. The table is now locked at the desired angle.

Positive stops are provided at 0°, 15°, 22.5°, 31.6° and 45° left and right.

**IMPORTANT:** Always tighten the miter table locking lever before performing every cutting operation.

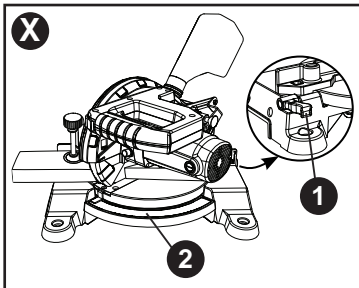

## BEVEL CUT (FIGURE Y)

- When a bevel cut is required, loosen the bevel lock handle (1).
- Tilt the cutting head to the desired angle, as shown on the bevel scale (2).
- The blade can be positioned at any angle, from a 90° straight cut (0° on the scale) to a 45° left bevel. Tighten the bevel lock handle (1) to lock the cutting head in position. Positive stops are provided at 0° and 45°.

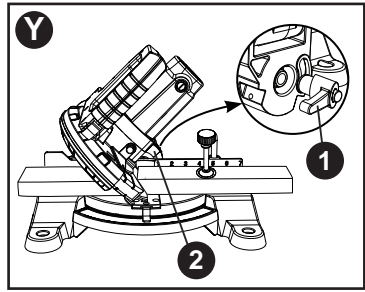

## COMPOUND CUT (FIGURE Z)

A compound cut is the combination of a miter and a bevel cut simultaneously.

- Loosen the bevel lock handle and position the cutting head at the desired bevel position. Lock the bevel lock handle. See "**BEVEL CUT.**"
- Loosen the miter table locking lever and position the table at the desired angle. Lock the miter table locking lever. See "**MITER CUT.**"

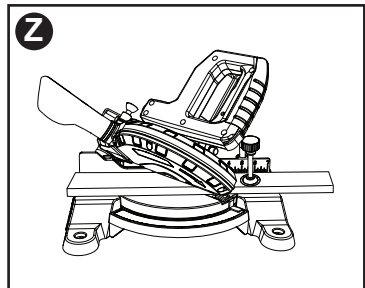

## CUTTING BOWED MATERIAL (FIGURE AA)

**⚠ WARNING** To avoid injury from materials being thrown, always unplug the saw to avoid accidental starting and remove small pieces of material from the table cavity.

- The table insert may be removed for this purpose, but always reattach table insert prior to performing a cutting operation.
- A bowed workpiece (1) must be positioned against the fence and secured with a clamping device (2) as shown before cutting. Do not position workpiece incorrectly or try to cut the workpiece without the support of the fence. This will cause the blade to bind and could result in personal injury.

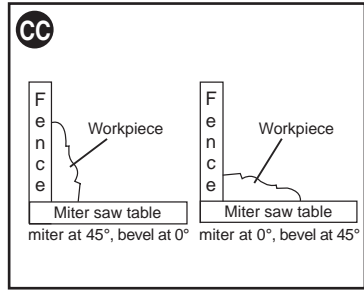
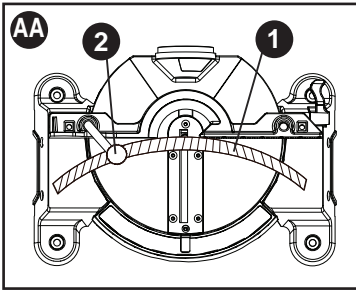

### WORKPIECE SUPPORT (FIGURE BB)

Long pieces need extra support. The support should be placed under the workpiece. Keep your hand holding the workpiece positioned 6-3/4 inches or more away from the blade. The support must let the workpiece lay flat on the work table during the cutting operation.

**NOTE:** When mounted on a flat surface, the saw table is 2-4/5 inches high.

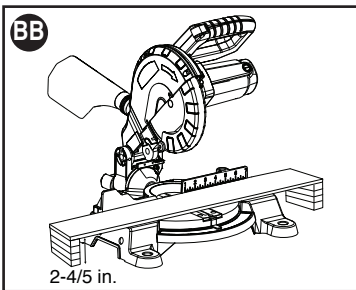

### CUTTING BASE MOLDING (FIGURE CC)

Base moldings and many other moldings can be cut on a compound miter saw. The setup of the saw depends on molding characteristics and application, as shown. Perform practice cuts on scrap material to achieve best results:

- Always make sure moldings rest firmly against fence and table. Use hold-down, crown molding vise or C-clamps, whenever possible, and place tape on the area being clamped to avoid marks.
- Reduce splintering by taping the cut area prior to making the cut. Mark the cut line directly on the tape.
- Splintering typically happens due to an incorrect blade application and thinness of the material.

**NOTE:** Always perform a dry run cut so you can determine if the operation being attempted is possible before power is applied to the saw.

### CUTTING CROWN MOLDING (FIGURE DD, EE)

Your compound miter saw is suited for the difficult task of cutting crown molding. To fit properly, crown molding must be compound-mitered with extreme accuracy. The two surfaces on a piece of crown molding that fit flat against the ceiling and wall are at angles that, when added together equal exactly 90°.

Most crown molding has a top rear angle (the section that fits flat against the ceiling) of 52° and a bottom rear angle (the section that fits flat against the wall) of 38°.

In order to accurately cut crown molding for a 90° inside or outside corner, lay the molding with its broad back surface flat on the saw table.

When setting the bevel and miter angles for compound miters, remember that the settings are interdependent; changing one changes the other, as well.

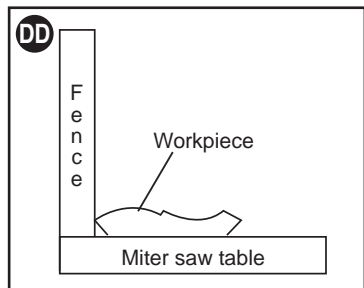

Settings for standard crown molding lying flat on compound miter saw table.

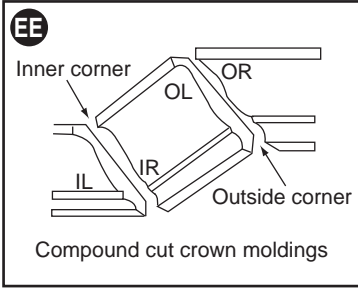

### Bevel/Miter Settings

**NOTE:** The chart below references a compound cut for crown molding ONLY WHEN THE ANGLE BETWEEN THE WALLS EQUALS 90°.

KEY	BEVEL SETTING	MITER SETTING	TYPE OF CUT
Inside corner-Left side			
IL	33.9°	31.6° Right	<ol style="list-style-type: none"> <li>1. Position top of molding against fence.</li> <li>2. Miter table set at RIGHT 31.6°.</li> <li>3. LEFT side is finished piece.</li> </ol>
Inside corner-Right side			
IR	33.9°	31.6° Left	<ol style="list-style-type: none"> <li>1. Position bottom of molding against fence.</li> <li>2. Miter table set at LEFT 31.6°.</li> <li>3. LEFT side is finished piece.</li> </ol>
Outside corner-Left side			
OL	33.9°	31.6° Left	<ol style="list-style-type: none"> <li>1. Position bottom of molding against fence.</li> <li>2. Miter table set at LEFT 31.6°.</li> <li>3. RIGHT side is finished piece.</li> </ol>
Outside corner-Right side			
OR	33.9°	31.6° Right	<ol style="list-style-type: none"> <li>1. Position top of molding against fence.</li> <li>2. Miter table set at RIGHT 31.6°.</li> <li>3. RIGHT side is finished piece.</li> </ol>

# CROWN MOLDING CHART

## Compound Miter Saw Miter and Bevel Angle Settings Wall to Crown Molding Angle

Angle Between Walls	52/38° Crown Molding		45/45° Crown Molding	
	Miter Setting	Bevel Setting	Miter Setting	Bevel Setting
67	42.93	41.08	46.89	36.13
68	42.39	40.79	46.35	35.89
69	41.85	40.50	45.81	35.64
70	41.32	40.20	45.28	35.40
71	40.79	39.90	44.75	35.15
72	40.28	39.61	44.22	34.89
73	39.76	39.30	43.70	34.64
74	39.25	39.00	43.18	35.38
75	38.74	38.69	42.66	34.12
76	38.24	38.39	42.15	33.86
77	37.74	38.08	41.64	33.60
78	37.24	37.76	41.13	33.33
79	36.75	37.45	40.62	33.07
80	36.27	37.13	40.12	32.80
81	35.79	36.81	39.62	32.53
82	35.31	36.49	39.13	32.25
83	34.83	36.17	38.63	31.98
84	34.36	35.85	38.14	31.70
85	33.90	35.52	37.66	31.42
86	33.43	35.19	37.17	31.14
87	32.97	34.86	36.69	30.86
88	32.52	34.53	36.21	30.57
89	32.07	34.20	35.74	30.29
90	31.62	33.86	35.26	30.00
91	31.17	33.53	34.79	29.71
92	30.73	33.19	34.33	29.42
93	30.30	32.86	33.86	29.13
94	29.86	32.51	33.40	28.83
95	29.43	32.17	32.94	28.54
96	29.00	31.82	32.48	28.24
97	28.58	31.48	32.02	27.94
98	28.16	31.13	31.58	27.64
99	27.74	30.78	31.13	27.34
100	27.32	30.43	30.68	27.03
101	26.91	30.08	30.24	26.73
102	26.50	29.73	29.80	26.42
103	26.09	29.38	29.36	26.12
104	25.69	29.02	28.92	25.81
105	25.29	28.67	28.48	25.50
106	24.89	28.31	28.05	25.19
107	24.49	27.96	27.62	24.87
108	24.10	27.59	27.19	24.56
109	23.71	27.23	26.77	24.24
110	23.32	26.87	26.34	23.93
111	22.93	26.51	25.92	23.61
112	22.55	26.15	25.50	23.29
113	22.17	25.78	25.08	22.97
114	21.79	25.42	24.66	22.66
115	21.42	25.05	24.25	22.33
116	21.04	24.68	23.84	22.01
117	20.67	24.31	23.43	21.68
118	20.30	23.94	23.02	21.36
119	19.93	23.57	22.61	21.03
120	19.57	23.20	22.21	20.70
121	19.20	22.83	21.80	20.38
122	18.84	22.46	21.40	20.05
123	18.48	22.09	21.00	19.72

Angle Between Walls	52/38° Crown Molding		45/45° Crown Molding	
	Miter Setting	Bevel Setting	Miter Setting	Bevel Setting
124	18.13	21.71	20.61	19.39
125	17.77	21.34	20.21	19.06
126	17.42	20.96	19.81	18.72
127	17.06	20.59	19.42	18.39
128	16.71	20.21	19.03	18.06
129	16.37	19.83	18.64	17.72
130	16.02	19.45	18.25	17.39
131	15.67	19.07	17.86	17.05
132	15.33	18.69	17.48	16.71
133	14.99	18.31	17.09	16.38
134	14.66	17.93	16.71	16.04
135	14.30	17.55	16.32	15.70
136	13.97	17.17	15.94	15.36
137	13.63	16.79	15.56	15.02
138	13.30	16.40	15.19	14.62
139	12.96	16.02	14.81	14.34
140	12.63	15.64	14.43	14.00
141	12.30	15.25	14.06	13.65
142	11.97	14.87	13.68	13.31
143	11.64	14.48	13.31	12.97
144	11.31	14.09	12.94	12.62
145	10.99	13.71	12.57	12.29
146	10.66	13.32	12.20	11.93
147	10.34	12.93	11.83	11.59
148	10.01	12.54	11.46	11.24
149	9.69	12.16	11.09	10.89
150	9.37	11.77	10.73	10.55
151	9.05	11.38	10.36	10.20
152	8.73	10.99	10.00	9.85
153	8.41	10.60	9.63	9.50
154	8.09	10.21	9.27	9.15
155	7.77	9.82	8.91	8.80
156	7.46	9.43	8.55	8.45
157	7.14	9.04	8.19	8.10
158	6.82	8.65	7.83	7.75
159	6.51	8.26	7.47	7.40
160	6.20	7.86	7.11	7.05
161	5.88	7.47	6.75	6.70
162	5.57	7.08	6.39	6.35
163	5.26	6.69	6.03	6.00
164	4.95	6.30	5.68	5.65
165	4.63	5.90	5.32	5.30
166	4.32	5.51	4.96	4.94
167	4.01	5.12	4.61	4.59
168	3.70	4.72	4.25	4.24
169	3.39	4.33	3.90	3.89
170	3.08	3.94	3.54	3.53
171	2.77	3.54	3.19	3.10
172	2.47	3.15	2.83	2.83
173	2.15	2.75	2.48	2.47
174	1.85	2.36	2.12	2.12
175	1.54	1.97	1.77	1.77
176	1.23	1.58	1.41	1.41
177	0.92	1.18	1.06	1.06
178	0.62	0.79	0.71	0.71
179	0.31	0.39	0.35	0.35

## MAINTENANCE

### **⚠ WARNING**

- To reduce the risk of injury, turn unit off and disconnect it from power source before installing and removing accessories, before adjusting or when making repairs. An accidental start-up can cause injury.
- DO NOT touch the sharp points on the blade with fingers or hands while performing any maintenance.

### **⚠ DANGER**

- To avoid injury, never put lubricants on the blade while it is spinning.
- DO NOT use lubricants or cleaners (particularly spray or aerosol) in the vicinity of the plastic guard. The plastic material used in the guard is subject to attack by certain chemicals.

### **⚠ WARNING**

- To avoid fire or toxic reaction, never use gasoline, naphtha acetone, lacquer thinner or similar highly volatile solvents to clean the miter saw.
- To avoid injury from unexpected starting or electrical shock, unplug the power cord before working on the saw.
- For your safety, this saw is double insulated. To avoid electrical shock, fire or injury, use only parts identical to those identified in the parts list. Reassemble exactly as the original assembly to avoid electrical shock.

## REPLACING CARBON BRUSHES (FIGURE FF)

The carbon brushes furnished will last approximately 50 hours of running time, or 10,000 ON/OFF cycles. Replace both carbon brushes when either has less than 1/4 in. length of carbon remaining, or if the spring or wire is damaged or burned. To inspect or replace brushes, first unplug the saw. Then remove the plastic cap (1) on the side of the motor (2). Remove the cap cautiously, because it is springloaded. Then pull out the brush and replace.

Replace for the other side. To reassemble reverse the procedure. The ears on the metal end of the assembly go in the same hole the carbon part fits into. Tighten the cap snugly, but do not overtighten. Repeat for the carbon brush located on the other side of motor.

**NOTE:** To reinstall the same brushes, first make sure the brushes go back in exactly the way they came out. This will avoid a break-in period that reduces motor performance and increases wear.

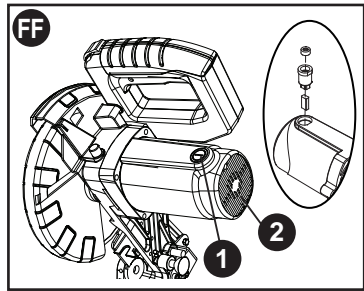

## LOWER BLADE GUARD

Do not use the saw without the lower blade guard. The lower blade guard is attached to the saw for your protection. Should the lower guard become damaged, do not use the saw until the damaged guard has been replaced. Develop a regular check to make sure the lower guard is working properly. Clean the lower guard of any dust or buildup with a damp cloth.

### **⚠ WARNING**

- When cleaning the lower guard, unplug the saw from the power source receptacle to avoid unexpected startup.
- Do not use solvents on the guard. They could make the plastic "cloudy" and brittle.

## SAWDUST

Periodically, sawdust will accumulate under the work table and base. This could cause difficulty in the movement of the worktable when setting up a miter cut. Frequently blow out or vacuum up the sawdust.

To empty the dust bag, remove the sawdust bag from the dust collection port. Open the zipper on the sawdust bag and empty out the sawdust inside. Close the zipper and reinstall the dust bag as described on page 13.

**⚠ WARNING** Wear proper eye protection to keep debris from entering eyes when removing sawdust from unit.

## LUBRICATION (FIGURE GG)

All the motor bearings in this tool are lubricated with a sufficient amount of high grade lubricant for the life of the unit under normal operating conditions; therefore, no further bearing lubrication is required.

Lubricate the following as necessary:

**Chop pivot (1):** Apply light machine oil to points indicated in illustration.

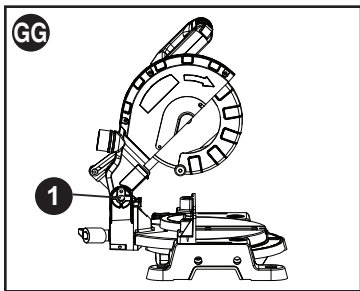

## ACCESSORIES

Recommended accessories for use with your tool are available from your local dealer or authorized service center. If you need assistance regarding accessories, please call: **1-844-437-5095**.

**⚠ WARNING** The use of any accessory not recommended for use with this tool could be hazardous.

## SERVICE INFORMATION

All Black+Decker Service Centers are staffed with trained personnel to provide customers with efficient and reliable power tool service. Whether you need technical advice, repair or genuine factory replacement parts, contact the Black+Decker location nearest you. To find your local service location, call: **1-844-437-5095** or visit [www.blackanddecker.com](http://www.blackanddecker.com)

## FULL TWO-YEAR HOME USE WARRANTY

Black+Decker warrants this product for two years against any defects in material or workmanship. The defective product will be replaced or repaired at no charge in either of two ways.

The first, which will result in exchanges only, is to return the product to the retailer from whom it was purchased (provided that the store is a participating retailer). Returns should be made within the time period of the retailer's policy for exchanges (usually 30 to 90 days after the sale). Proof of purchase may be required. Please check with the retailer for their specific return policy regarding returns that are beyond the time set for exchanges. The second option is to take or send the product (prepaid) to a Black+Decker owned or authorized Service Center for repair or replacement at our option. Proof of purchase may be required. This warranty does not apply to accessories. This warranty gives you specific legal rights and you may have other rights which vary from state to state or province to province. Should you have any questions, contact the manager of your nearest Black+Decker Service Center. This product is not intended for commercial use.

## FREE WARRANTY LABEL REPLACEMENT:

If your warning labels become illegible or are missing, call **1-844-437-5095** for a free replacement.



**LATIN AMERICA:** This warranty does not apply to products sold in Latin America. For products sold in Latin America, check country specific warranty information contained in the packaging, call the local company or see the website for warranty information.

## TROUBLESHOOTING

### SAW OPERATION

<u>Problem</u>	<u>Possible Cause</u>	<u>Possible Solution</u>
• Blade hits table.	• Misalignment.	• See ADJUSTMENT -Setting Cutting Depth section.
• Angle of cut not accurate. Can not adjust miter.	• Miter table unlocked. • Sawdust under table.	• See OPERATION - Miter Angle Adjustment section. • Vacuum or blow out dust. WEAR EYE PROTECTION.
• Cutting arm wobbles.	• Loose pivot points.	• Contact Service Center.
• Cutting arm will not fully raise, or blade guard won't fully close.	• Pivot spring not replaced properly after service. • Sawdust build-up.	• Clean and lubricate moving parts. • Contact Service Center.
• Blade binds, jams, burns wood.	• Improper operation. • Dull or warped blade. • Improper blade size.  • Wood is moving during cut.	• See BASIC SAW OPERATION section. • Replace or sharpen blade. • Replace with 7-1/4 in. diameter blade. • Use hold-down clamp to secure workpiece to table.
• Saw vibrates or shakes.	• Saw blade not round / damaged / loose. • Arbor bolt loose.	• Replace blade.  • Tighten arbor bolt.

## MOTOR

<b><u>Problem</u></b>	<b><u>Possible Cause</u></b>	<b><u>Possible Solution</u></b>
<ul style="list-style-type: none"><li>• Motor does not start.</li></ul>	<ul style="list-style-type: none"><li>• Limit switch failure</li><li>• Brush worn.</li></ul>	<ul style="list-style-type: none"><li>• Replace limit switch.</li><li>• Replace brushes. See MAINTENANCE section.</li><li>• Verify there is electrical power at the outlet.</li></ul>
<ul style="list-style-type: none"><li>• Brush spark when switch released.</li></ul>	<ul style="list-style-type: none"><li>• Fuse blown or circuit breaker tripped on home panel.</li><li>• Brush worn.</li><li>• Other.</li></ul>	<ul style="list-style-type: none"><li>• Replace Brushes. See MAINTENANCE section.</li><li>• Contact Service Center.</li></ul>

For assistance with your product, visit our website [www.blackanddecker.com](http://www.blackanddecker.com) for the location of the service center nearest you or call the BLACK+DECKER help line at **1-844-437-5095**.

BLACK+DECKER and the BLACK+DECKER logo are registered trademarks of BLACK+DECKER and are used under license. All rights reserved.

**BLACK+DECKER**

Imported by  
Power Tool Specialists, Inc.  
684 Huey Road  
Rock Hill, SC 29730 U.S.A.

# PARTS LIST

## 7-1/4 IN. MITER SAW PARTS LIST FOR MITER SAW - (1)

**MODEL NO. M1850BD**

I.D.	Description	Size	Q'ty	I.D.	Description	Size	Q'ty
X6VM	BAG-DUST ASS'Y		1	X6WU	COMPRESSION SPRING		1
X6VN	PC-GUARD ASS'Y		1	X6WV	C-RING	ø8	1
X6VR	WISE ASS'Y		1	X6WW	LOCATOR PIN		1
X6VW	O-RING	ø10*ø1.9	1	X6WX	HANDLE		1
X6VX	CR. RE. PAN HD. SCREW	M5*8	2	X6WY	BALL BEARING		1
X6VY	RING	ø6	1	X6WZ	FLOW GUIDE		1
X6VZ	ROLLING WHEEL		1	X6X0	CR. RE. PAN HD. SCREW	M5*25	1
X6W0	SHAFT SLEEVE		1	X6X1	COVER		1
X6W1	SPRING WASHER	ø8	1	X6X2	ARM		1
X6W2	CR. RE. PAN HD. TAPPING SCREW		6	X6X3	INSTRUCTION MANUAL		1
X6W4	MOTOR HANDLE (TOP)		1	X6X4	DAMPER		1
X6W6	TRIGGER		1	X6X5	HOUSING		1
X6W7	LIMIT SWITCH		1	X6X6	CR. RE. PAN HD. SCREW	M5*16	3
X6W8	WISE BEARING		1	X6X7	TRADEMARK LABEL		1
X6W9	ROCKER SWITCH		1	X6X8	COVER PLATE		1
X6WA	CR. RE. PAN HD. SCREW	M5*12	2	X6X9	CR. RE. COUNT HD. SCREW	M5	1
X6WB	CR. RE. PAN HD. TAPPING SCREW	ST3.9*14	2	X6XA	BLADE WRENCH		1
X6WC	CORD CLAMP		1	X6XB	HEX. HD. BOLT	M6*15	1
X6WD	POWER CABLE		1	X6XC	FOLLOWER PLATE		1
X6WE	GUARD-CORD		1	X6XD	BLADE		1
X6WF	MOTOR HANDLE (DOWN)		1	X6XE	FOLLOWER PLATE		1
X6WG	LABEL		1	X6XF	RING	ø38	1
X6WH	BRUSH COVER		2	X6XG	PC-GUARD		1
X6WJ	CARBON BRUSH ASS'Y		2	X6XH	SPRING		1
X6WK	BRUSH HOLDER ASS'Y		2	X6XJ	CR. RE. COUNT HD. SCREW	M5*12	2
X6WL	FLAT WASHER	ø5	6	X6XK	BEARING SEAT		1
X6WM	CR. RE. PAN HD. SCREW	M5*35	4	X6XL	BALL BEARING		1
X6WN	MOTOR COVER		1	X6XM	RING	ø32	1
X6WP	TRADEMARK LABEL		1	X6XN	CUTTER SHAFT		1
X6WQ	BALL BEARING		1	X6XP	PARALLEL KEY	4*12	1
X6WR	STATOR CORE ASS'Y		1	X6XQ	HELIX GEAR		1
X6WS	CR. RE. PAN HD. TAPPING SCREW		2	X6XR	BRAKE BLOCK		1
X6WT	ARMATURE ASS'Y		1				

**7-1/4 IN. MITER SAW  
PARTS LIST FOR MITER SAW - (2)**

**MODEL NO. M1850BD**

I.D.	Description	Size	Q'ty	I.D.	Description	Size	Q'ty
X6XS	NEEDLE ROLLER BEARING		1	X6YQ	HEX. SOC. HD. CAP BOLT		1
X6XT	HANDLE		1	X6YR	TILT POINTER		1
X6XU	WARNING LABEL		1	X6YS	TABLE		1
X6XV	HEX. HD. BOLT	M5*16	1	X6YT	HANDLE BAR ASS'Y		1
X6XW	FLAT WASHER	ø12* ø24*2.5	2	X6YU	WISE BEARING		1
X6XX	LOCK NUT	M12	1	X6YV	FLANGE		1
X6XY	CR. RE. COUNT HD. SCREW		1	X6YW	FLAT WASHER	ø6	1
X6XZ	LOCK NUT	M5	1	X6YX	CR. RE. COUNT HD. SCREW	M4	1
X6Y0	SUPPORT PLATE		1	X6YY	FENCE		1
X6Y1	HEX. SOC. HD. CAP BOLT	M5*12	2	X6YZ	HEX. SOC. HD. CAP BOLT	M8*25	2
X6Y2	SPRING WASHER	ø5	6	X6Z0	FLAT WASHER	ø8	2
X6Y3	SHAFT SLEEVE		1	X6Z1	SHAFT SLEEVE		4
X6Y4	CR. RE. COUNT HD. SCREW		1	X6Z2	SHAFT SLEEVE		2
X6Y5	ANGLE PEGULATOR		1	X6Z3	BRACING PLATE		1
X6Y6	HANDLE		1	X6Z4	EXTENTION WING		1
X6Y7	LOCATOR PIN		1	X6Z5	CR. RE. PAN HD. SCREW	M4*8	3
X6Y8	TILT POINTER		1	X6Z6	STEEL BALL	ø10	1
X6Y9	HEX. NUT	M5	1	X6Z7	SPRING		2
X6YA	ANCHOR BLOCK		1	X6Z8	HEX. SOC. HD. CAP BOLT	M10*10	1
X6YB	BOLT	M12	1	X6Z9	WARNING LABEL		1
X6YC	CR. RE. PAN HD. SCREW	M5*14	1	X6ZA	BASE		1
X6YD	CR. RE. PAN HD. SCREW	M5*8	2	X6ZB	FOOT		4
X6YE	BOLT		1	X6ZC	TILTING SCALE		1
X6YF	TILTING SCALE		1	X6ZD	FLAT WASHER	ø10*ø20*2	1
X6YG	HEX. SOC. HD. CAP BOLT	M6*8	1	X6ZE	LOCK NUT	M10	1
X6YH	HEX. SOC. HD. CAP BOLT	M6*14	2	X6ZF	WARNING LABEL		1
X6YJ	HEX. NUT	M6	2	X6ZG	SCREW		1
X6YK	CR. RE. COUNT HD. SCREW		1	X6ZH	HANDLE BAR ASS'Y		1
X6YL	TORSION SPRING		1	X6ZJ	COMPRESSION SPRING		1
X6YM	SHAFT-PIVOT		1	X6ZK	CR. RE. COUNT HD. SCREW		1
X6YN	CR. RE. COUNT HD. SCREW	M4*8	5	X6ZL	WARNING LABEL		2
X6YP	TABLE INSERT		1	X6ZM	LABEL		1

7-1/4 IN. MITER SAW  
SCHEMATIC

MODEL NO. M1850BD

