



We strive to ensure that our products are of the highest quality and free of manufacturing defects or missing parts. However, if you have any problems with your new product,

DO NOT RETURN IT TO THE STORE,

please contact us toll free @:

1-866-556-2757

FAX: 1-866-873-3531

pooltables@escaladesports.com

Or write to:

Escalade Sports
Customer Service Department
P.O. Box 889
Evansville IN 47706

Please visit our Web site at:

www.escaladesports.com

Please have your model number when inquiring about parts.

When contacting Escalade Sports please provide your model number, date code (if applicable) and part number if requesting a replacement part. These numbers are located on the product, packaging, and this owners manual.

Your Model Number **P5223W**

Date Code **2-P5223W-0910-WJ**

Purchase Date _____

PLEASE RETAIN THIS INSTRUCTION MANUAL FOR FUTURE REFERENCE



CAUTION



THE SPRAY ADHESIVE USED FOR APPLYING PLAYFIELD CLOTH IS EXTREMELY FLAMMABLE AND UNDER PRESSURE !CAREFULLY READ CAUTIONS ON SPRAY ADHESIVE CONTAINER !KEEP OUT OF THE REACH OF CHILDREN ! DO NOT USE OR STORE NEAR HEAT SOURCE , FLAMES , SPARKS OR WHEN SMOKING! WORK AREA MUST BE WELL VENTILATED. OPEN DOORS AND WINDOWS WHEN USING SPRAY ADHESIVE .

To ensure safety, do not attempt to assemble system without following instructions carefully. Proper and complete assembly, use, and supervision is essential for proper operation and to reduce the risk of accident or injury. A high probability of serious injury exists if this system is not installed, maintained, and operated properly.



WARNING:

READ AND FOLLOW ALL ASSEMBLY, OPERATION, AND SAFETY INSTRUCTIONS CAREFULLY. AT LEAST TWO ADULTS ARE NEEDED TO PUT THIS TABLE TOGETHER.



IMPORTANT



THE DRAWINGS IN THIS MANUAL MAY BE EXAGGERATED OR MODIFIED TO SHOW DETAILS.



Tools Needed: (Not Included)

- Philips Screwdriver
- Putty Knife
- Needle Nose Pliers
- Tape Measure
- Sanding Block
- Scissors or Sharp Knife
- Adjustable Wrench
- Small Hammer
- Carpenters Level
- Ratchet with socket

NOTE: This table adds weight to any floor. Be sure floor can withstand this kind of weight. If floor sags, table will be impossible to level.

Part List

(To Scale)

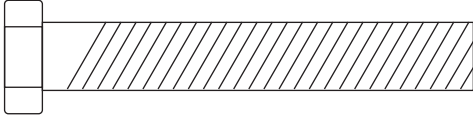

H1 - 3/8" x 2-1/4" Bolt
8 Pcs

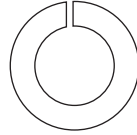

H2 - 3/8" Spring
Washer 16 Pcs

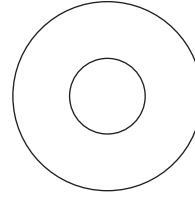

H3 - 3/8" x 25mm Washer
32 Pcs

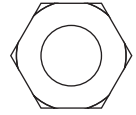

H4 - 3/8" Hex Nut
16 Pcs

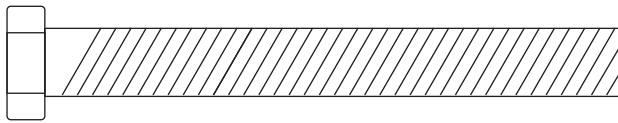

H5 - 3/8" x 3" Bolt
8 Pcs

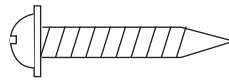

H6 - WP/4 x 1"
Round Washer Head Screw
8 Pcs

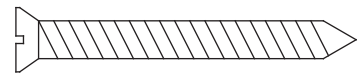

H7 - F5 x 1-3/4"
Flat Head Screw
16 Pcs

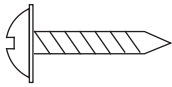

H8 - WP/3 x 18mm
Round Washer Head Screw
24 Pcs

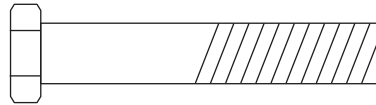

H9 - 5/16" x 1-3/4" Bolt
12 Pcs

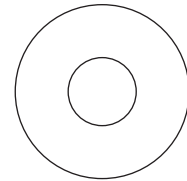

H10 - 5/16" x 23mm
Washer 12 pcs

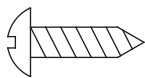

H11 - T4 x 15mm
Round Head Screw
24 Pcs

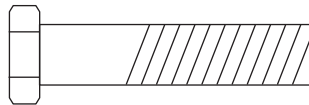

H12 - 5/16" x 1-1/2" Bolt
18 Pcs

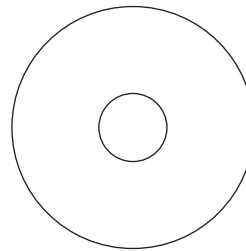

H13 - 5/16" x 32 Washer
18 Pcs

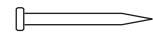

H14 - Pocket Nail
24 Pcs

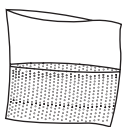

T1-Grout Kit
1 Pc

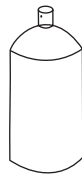

T2-Spray Adhesive
1 Pc

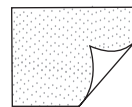

T3-Sand Paper
1 Pc

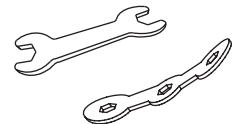

T4-Wrench
1 Set

A1

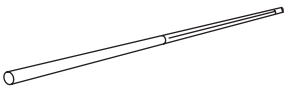

Cue Stick
2 Pcs

A2

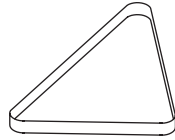

Triangle
1 Pc

A3

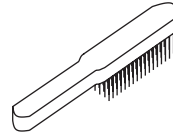

Brush
1 Pc

A4

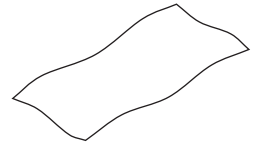
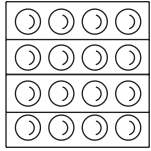

Table Cloth
1 Pc

A5



Billiard Ball
1 Set

A6

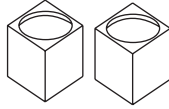

Chalk
2 Pcs

P1

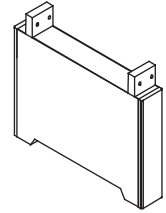

Leg
2 Pcs

P2

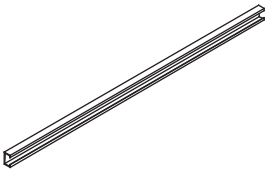

Main Metal Beam
2 Pcs

P3

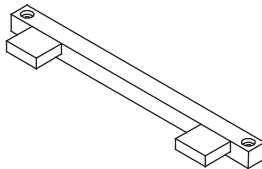

End Slat
2 Pcs

P4

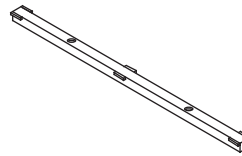

Middle Slat
2 Pcs

P5



Main Beam End Board
4 Pcs

P6-Slatron
P6S-Slate

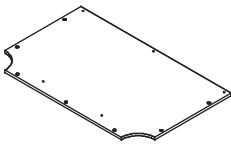

End Play Bed
2 Pcs

P7-Slatron
P7S-Slate

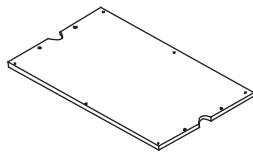

Middle Play Bed
1 Pc

P8



Shim
8 Pcs
use deck of cards for shimming
(not included)

P9

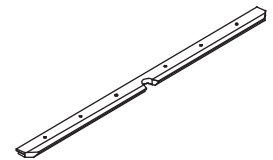

Side Top Rail
2 Pcs

P10

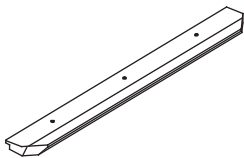

End Top Rail
2 Pcs

P11

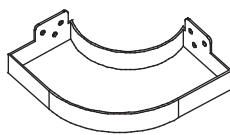

Corner Cap
4 Pcs

P12

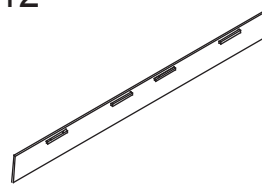

Side Apron
2 Pcs

P13

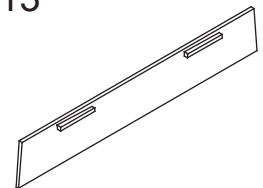

End Apron
2 Pcs

P14

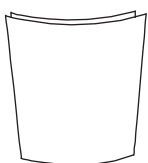

Corner Post
4 Pcs

P15

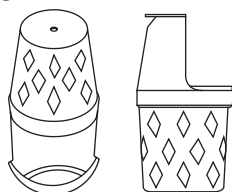

Corner Pocket
4 Pcs

P16

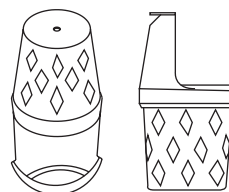

Side Pocket
2 Pcs

P17

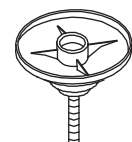

Leg Leveler
4 Pcs

PARTS REQUIRED:
2 pcs - P1 Leg
4 pcs - P17 Leg Leveler

STEP 1:
Thread P17 Leg Levelers into P1 Leg as shown in Figure 1

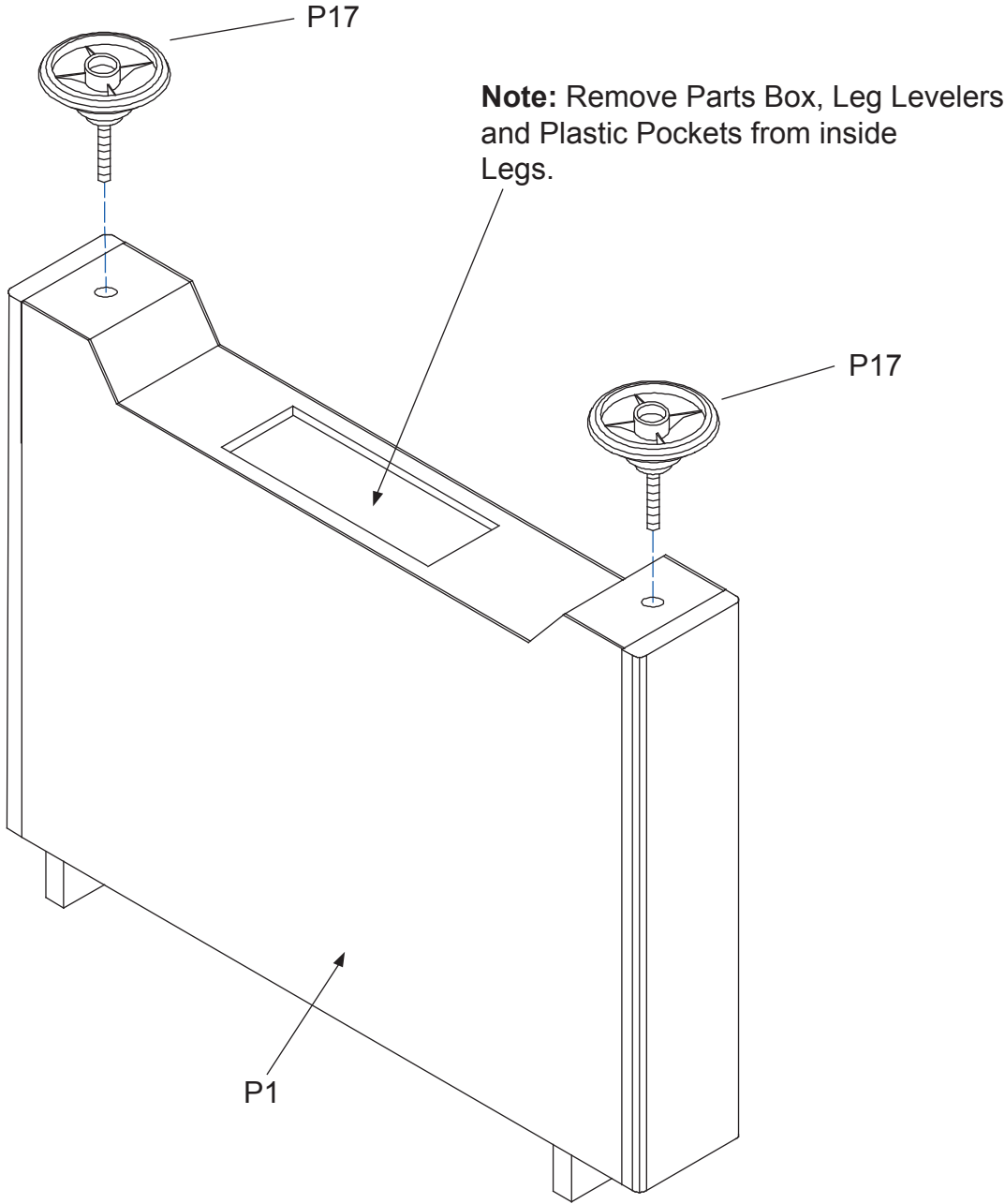

Figure 1

PARTS REQUIRED:

- | | |
|---------------------------|--------------------------------|
| 8 pcs - H1 Bolt | 8 pcs - H6 Screw |
| 16 pcs - H2 Spring Washer | 2 pcs - P2 Main Metal Beam |
| 32 pcs - H3 Washer | 2 pcs - P3 End Slat |
| 16 pcs - H4 Hex Nut | 2 pcs - P4 Middle Slat |
| 8 pcs - H5 Bolt | 4 pcs - P5 Main Beam End Board |
| | 1 set - T4 Wrench |

STEP 2:

Attach each P2 Main Metal Beam to P1 Leg assembly as shown Figure 2 using H1 Bolts, H3 Washers, H2 Spring Washers and H4 Hex Nuts. Use the T4 Wrench to assemble the hardware. **Do not tighten hardware at this time.** Place P3 End Slats and P4 Middle Slats across P2 Main Beams and attach using an H5 Bolts, H3 washers, H2 Spring Washers and H4 Hex Nuts. Attach the P5 Metal Beam End Boards using H6 Screws.

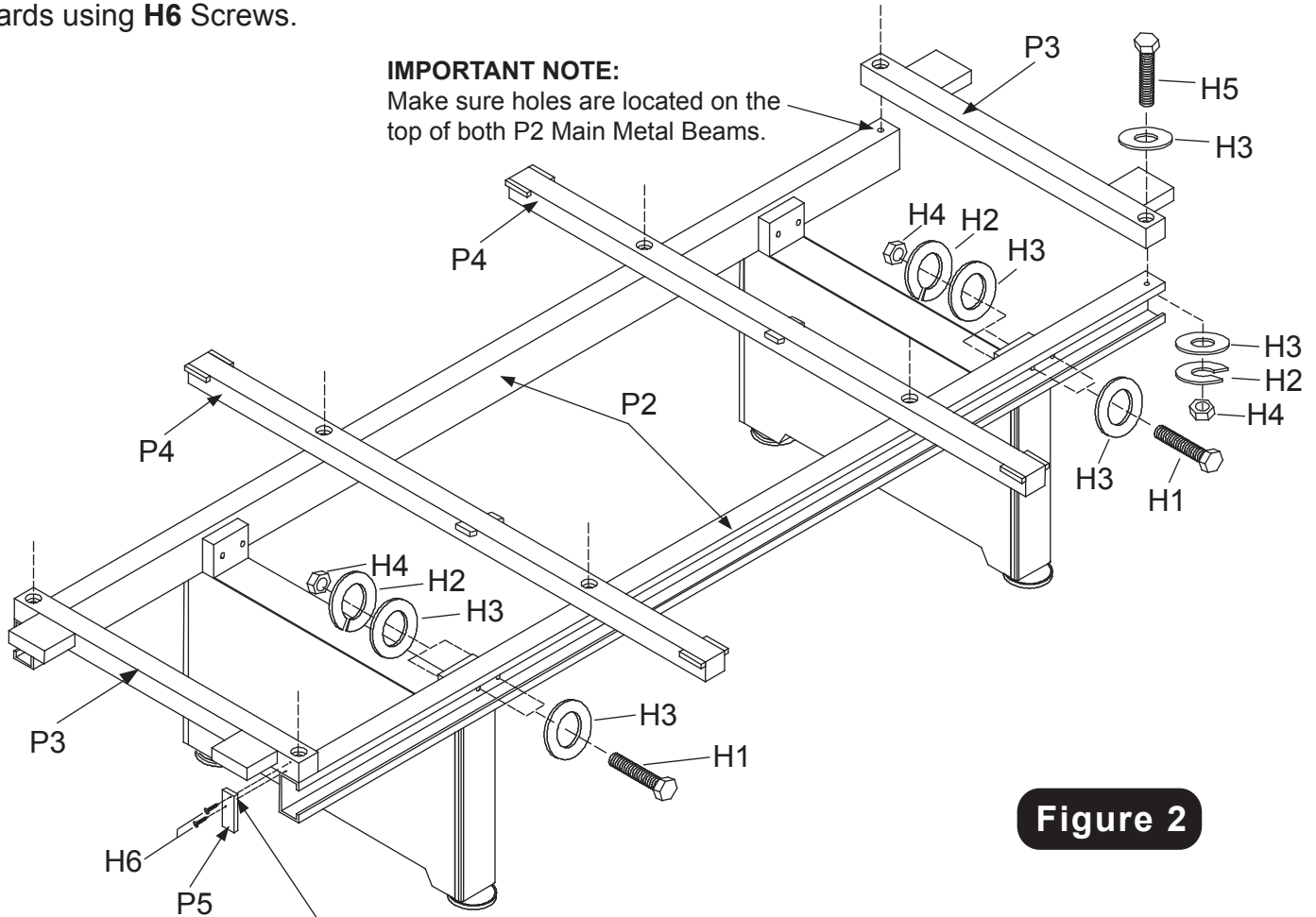

Figure 2

Note: P5 Main Beam End Boards must be flush or slightly lower than top of P3 End Slats.

STEP 3:

Square up P4 Slats by measuring diagonally as show in Figure 3. Diagonal measurements should be the same within 1/8". If the frame is not square, adjustment can be made by moving table beams P2 in opposite directions. Once the frame is square, tighten all hardware.

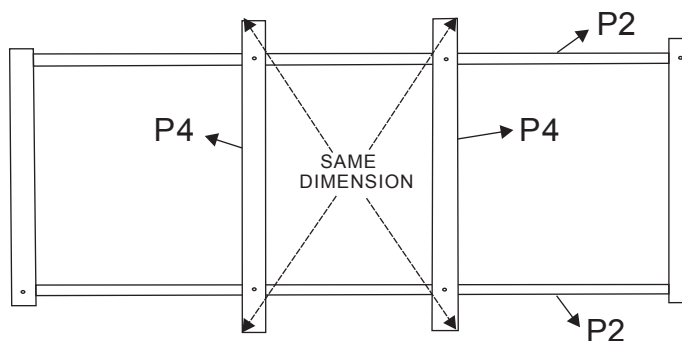

Figure 3

STEP 4:

Use a carpenter's level to level table as close as possible. It is easier to do it now rather than after the Play Bed is on the frame. To determine the highest corner of the frame place the level in following two positions. First check the table from end to end as shown in **Figure 4**. Then check the table at an angle as shown in **Figure 5**.

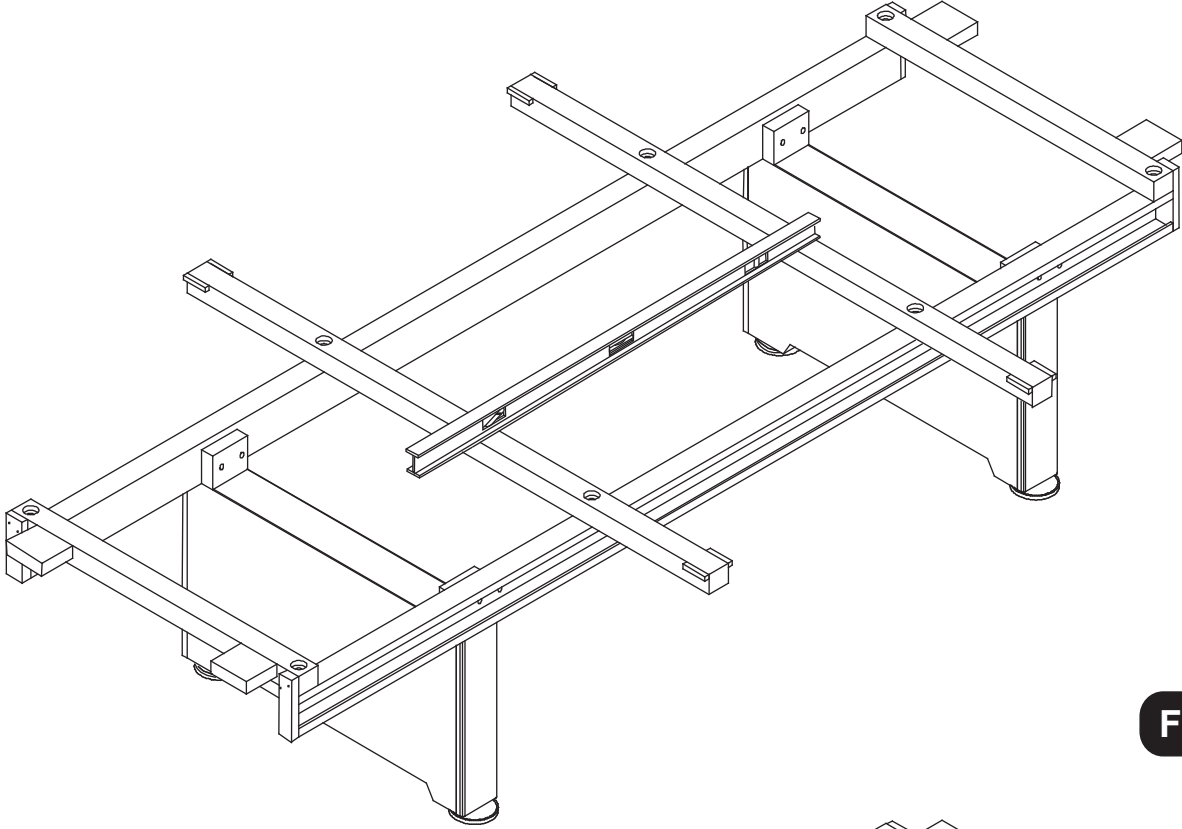

Figure 4

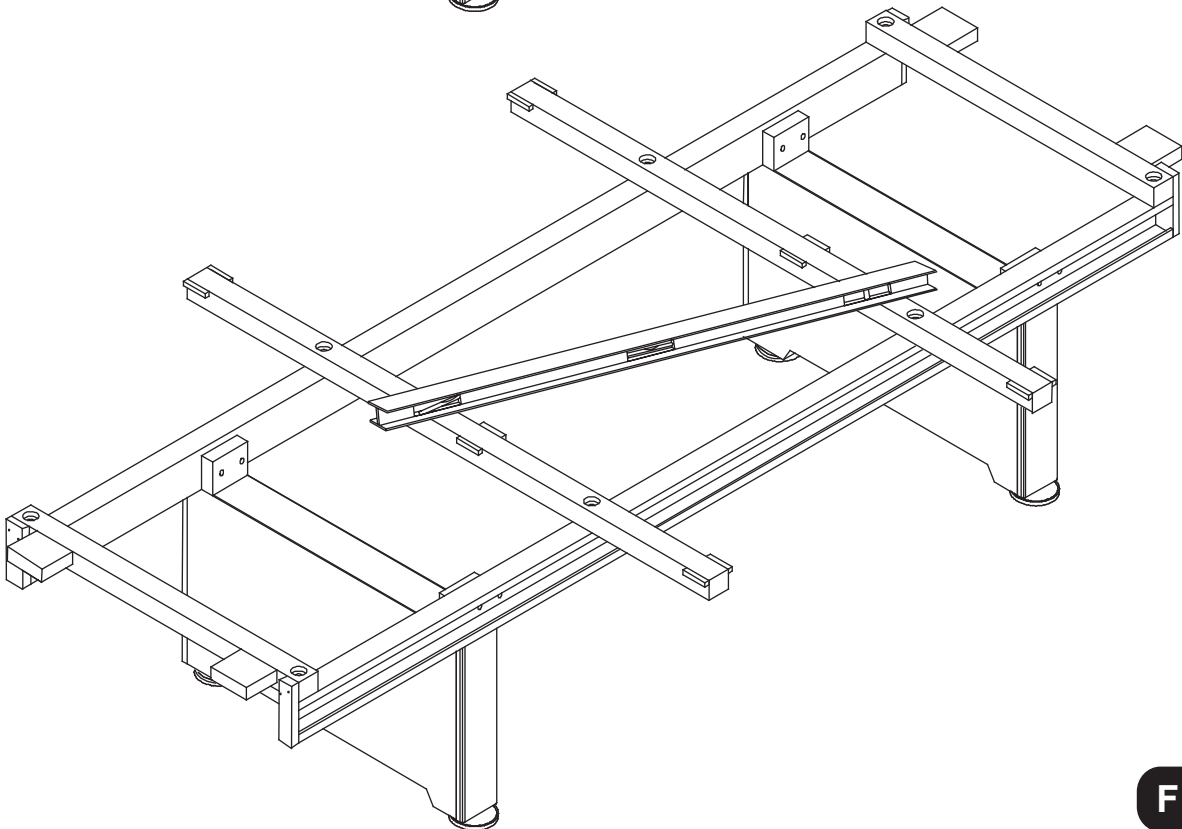

Figure 5

UNBOXING THE SLATE (Slate tables only:)



CAUTION

AFTER CRATE PARTS ARE REMOVED, BEND NAILS OR STAPLES OVER WITH A HAMMER AT ONCE! USE CAUTION WHEN HANDLING CRATE PARTS!

It is now time to uncrate the slate pieces. With a claw hammer or crow bar, pry off crate top at the notched corner. (See **FIGURE 6**) **BE CAREFUL NOT TO DAMAGE SLATE INSIDE! SLATE IS BRITTLE AND CAN BE EASILY DAMAGED IF HIT OR PRIED AGAINST!**

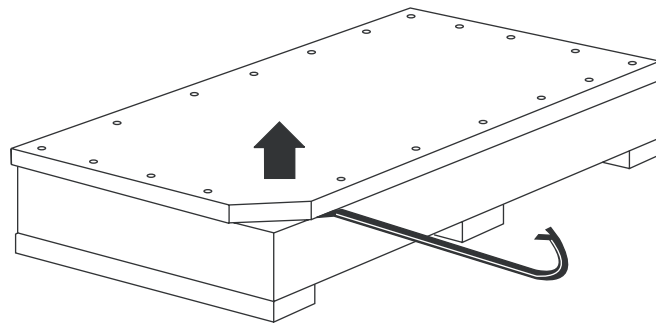

Figure 6

Remove the front rail of the crate. Slide the slate out the front of the crate. (**FIGURE 7**)

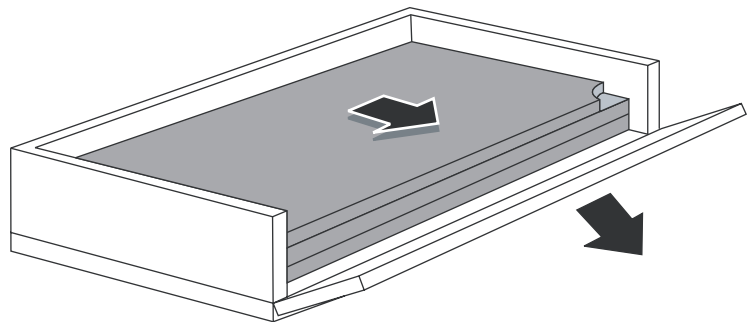

Figure 7

UNBOXING THE SLATRON (Slatron tables only:)

It is now time to unbox the slatron pieces. **BE CAREFUL NOT TO DAMAGE SLATRON INSIDE! SLATRON CAN BE EASILY DAMAGED IF HIT OR PRIED AGAINST!** (See **FIGURE 8**)

If the edges of your Slatron has “fuzz” on it, lightly sand to remove with sandpaper provided in the playbed kit.

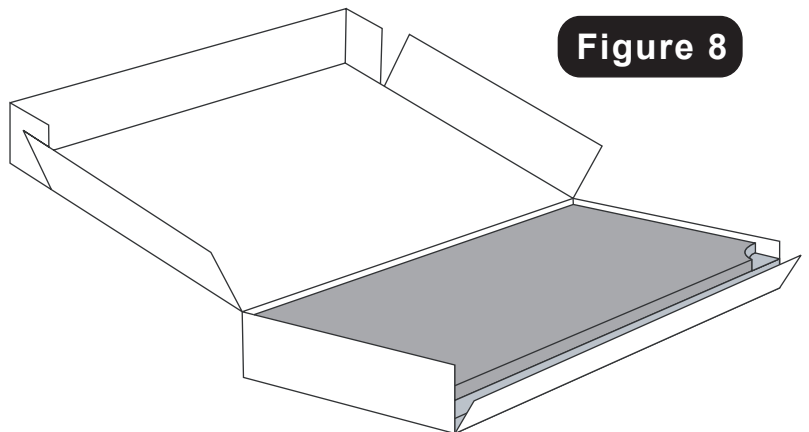

Figure 8

IMPORTANT!

The sheets of slatron may not be completely flat when removed from the shipping carton. This is normal. Once they have been placed on the table frame and securely fastened down, they will become straight and flat.

THE FOLLOWING STEP REQUIRES THE HELP OF ANOTHER ADULT!

- PARTS REQUIRED:**
16 pcs - **H7** Screw
2 pcs - **P6** End Play Bed
1 pcs - **P7** Middle Play Bed

STEP 5:

You can tell the top side of the playfield sections by the beveled edge of the pocket openings and the countersunk mounting holes. The beveled edges and the countersunk holes must face up. **(See Detail A)**

A) Place center section **P7** on the two long slats **P4**. If edges do not align exactly, center playfield as much as you can. The playfield sections are 51 inches wide. The **P4** Middle Slats are 51 inches long. The play bed sections should be flush with the **P4** Middle Slats on both sides of table.

WARNING: This step requires two adults!

REMEMBER: Be sure countersunk holes in the playfield face up!

B) Secure center section **P7** to long slats **P4** with screws **H7** into countersunk holes.

Note: It is important that the edges of the three pieces of playfield are flush and square.

DO NOT OVER TIGHTEN SCREWS!

Place end Play Bed section **P6** onto slats. Be sure they are square, in line and butted up tight against center section **P7**. Secure end section **P6** to beams using screws **H7** into countersunk holes. **DO NOT OVER TIGHTEN SCREWS. NOTE:** If necessary, shim underneath Play Bed where they join together to obtain a smooth, even surface. Shims are provided in the slate bed kit.

TOP OF PLAY BED MUST BE PRECISELY LEVEL! EDGES MUST BE EVEN WITH ONE ANOTHER!

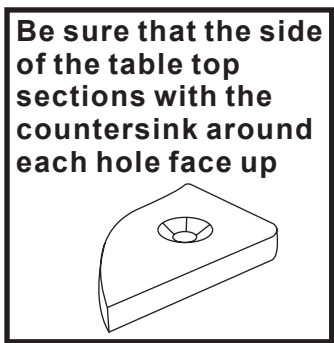

Detail A

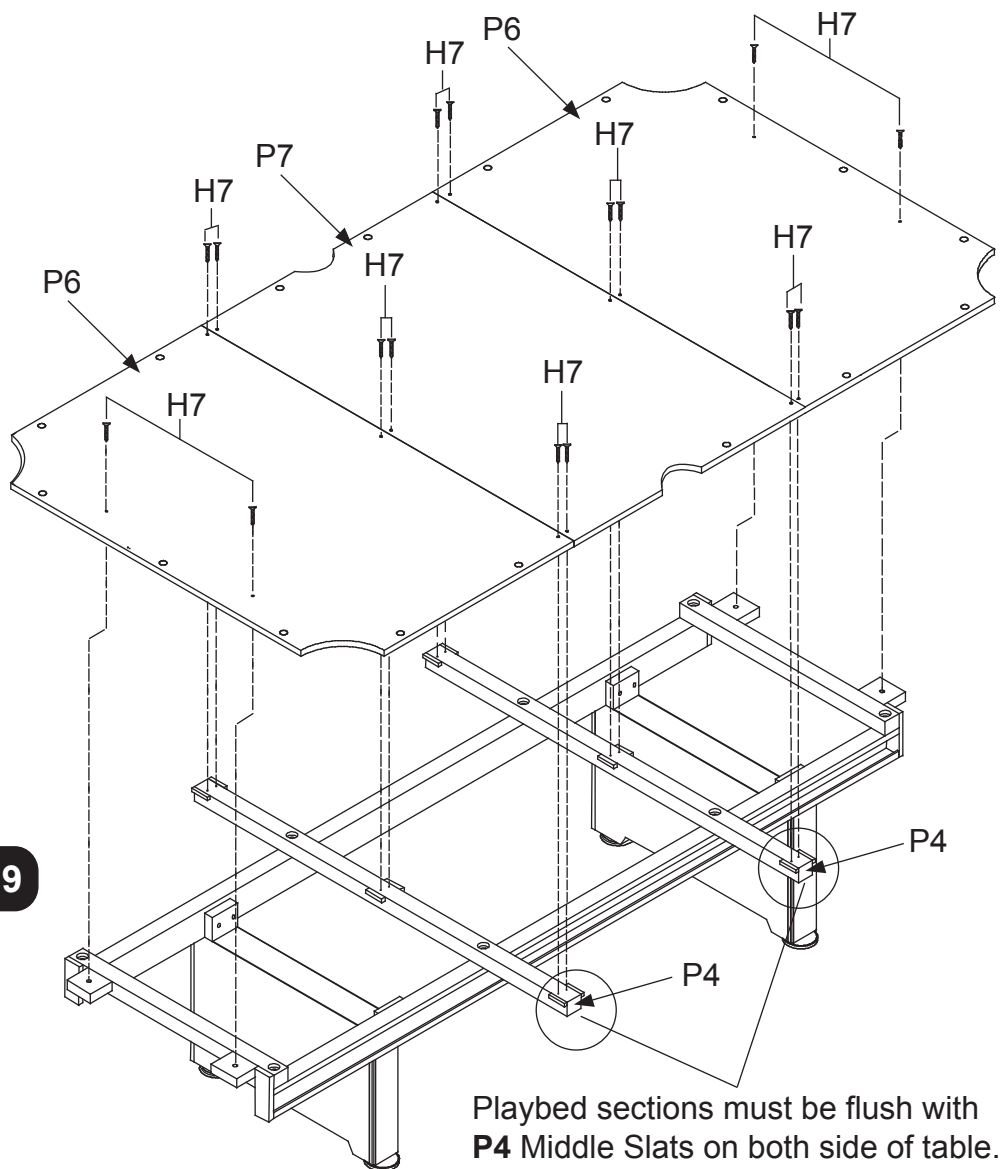

Figure 9

Playbed sections must be flush with **P4** Middle Slats on both side of table.

SHIMMING INSTRUCTIONS

(use deck of cards for shimming, not included)

General Rules

- Accomplish the leveling of the playing surface with as few shims as possible.
- Do not tap with a hammer or tighten screws unreasonably tight. You will not be able to compress the playing surface. You must shim up the playing surface to level. Shims are meant only to raise the low places at the seams and ends. Very short and low places should be grouted. Do not assume the floor is level. Most leveling can be accomplished by working with the frame.
- If using power tools be sure to use only enough torque to reasonably tighten screws.
- Seams can best be checked by passing your finger over the seam and feeling if it is flush.
- All screws must be tightened after shimming.
- No two sets of Play Bed are exactly alike. Some sets require more or less shimming than others.

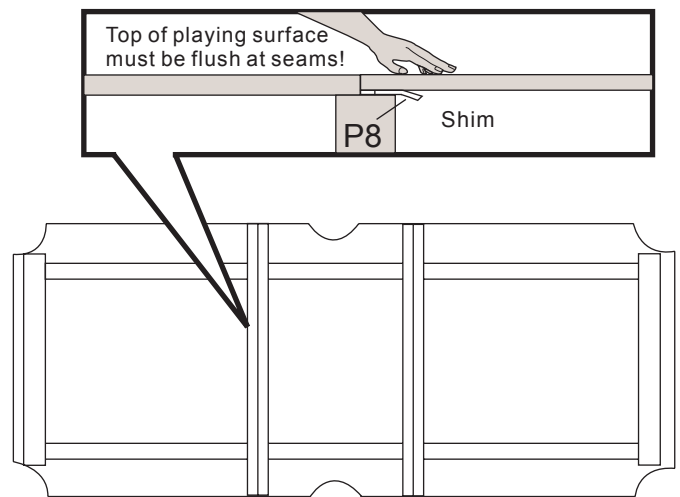

STEP BY STEP SHIMMING

(use deck of cards for shimming, not included)

- Be sure table is set in its final location.
- Table must be as level as possible before shimming. Large differences in levelness must be corrected by raising or lowering frame with included leg levelers or shim stock.
DO NOT ASSUME FLOOR IS LEVEL!
- Tighten down all the playing surface mounting screws.
- Check with a carpenter's level to determine where playfield is low on ends, and use finger tips to locate uneven spots at the seams. Loosen screws at these points and see if playfield comes up to flush. If so, detach individual shims from the sheet shipped with this table and place under these areas. **Place shims next to screws.**
- Lay a straight edge across seams to be sure playfield pieces are at the same height.
- After top surface of playfield is flat and level, all screws must be snugged down in tight position. **DO NOT OVER-TIGHTEN SCREWS!** Check these screws before proceeding to the next step.

GROUTING INSTRUCTIONS FOR PLAY BED

- Clean top of playfield with a damp cloth. **DO NOT USE TOO MUCH WATER!** Allow enough time for top sections to dry thoroughly before starting the next step.
- A small container of grout has been provided for filling countersinks and small imperfections in the table seams. Empty 1/3 of grout into a mixing container. Add 1 teaspoon of water and stir-add very small quantities of grout or water to achieve a thick paste. When mixed, grout should be a thick paste that will not drip off putty knife. If you do get grout too thin, slowly add more powder.
- Using a putty knife, fill both seams and the four countersunk holes in the center playfield area. (Only the four countersunk holes in the center of the table need to be filled since the other holes will be covered by the rails.) Do not use more grout than you need.
- Let grout dry. Read the rest of this manual while you wait!
- Using a medium grit sandpaper and sanding block, sand the filled areas smooth and flat.
RECHECK THESE AREAS TO MAKE SURE THEY ARE FLAT. Re-grout if you still find low places at countersunk holes or seams.

! WARNING !

DO NOT SMOKE WHILE WORKING WITH CONTACT CEMENT! READ LABEL ON CEMENT CONTAINER CAREFULLY!

Applying the cloth:

1. Make sure Play Bed is dry and free of dust.

NOTE: Before spraying adhesive, cut a portion of the shipping carton to use as a shield to prevent cement over spray.

2. Place cloth over Play Bed with equal overhang on all sides.

NOTE: Cloth may seem small but it will stretch a great deal.

3. Fold cloth away from end to expose Play Bed for your first glue application. Apply contact cement to top surface in a band 4 inches wide on this end. (See **FIGURE 10**) Coat edge also. Spray cement smoothly and evenly. Allow cement to become tacky, wait at least one minute.

4. Fold cloth back over the table. With firm even pressure, press cloth onto the area that has been coated with cement. Smooth cloth down and over edges.

5. Fold cloth away from side to expose Play Bed for your second glue application. (See **FIGURE 11**). Apply cement to the side in the same manner as your first glue application. Allow cement to become tacky, wait at least one minute.

6. Fold cloth back over table. With firm even pressure, press cloth onto the area that has been coated with cement. Smooth cloth down and over edges.

7. Fold cloth away from other side to expose Play Bed for your third glue application. (See **FIGURE 12**). Apply cement to this side in the same manner. Allow cement to become tacky, wait at least one minute.

8. Stretch the cloth across the width and over the edge of the table. **STRETCH HARD ENOUGH TO TAKE OUT WRINKLES, BUT NOT SO HARD THAT THE CLOTH SLIPS.**

9. Fold cloth away from other end to expose Play Bed for your fourth glue application. (See **FIGURE 13**) Apply cement to this end in the same manner. Allow cement to become tacky, wait at least one minute.

10. Make a final stretch along the length of and over the edge of the table, stretch hard enough to work out all wrinkles. (See **FIGURE 14**) If cloth is not smooth, lift and re-apply.

NOTE: Rubbing fingers lightly across cloth should not make cloth move.

11. Locate center of pocket opening. (See **Detail A** and **B**) Using sharp scissors, make a straight cut. Next, cut to pocket edge to form pie shapes. (See **detail B**) Divide these pie shapes in half. As you do, the pie shapes begin to relax to allow for placement. You may need to make additional cuts.

12. Spray adhesive on the underneath side of the play-bed around pocket face to adhere the cloth. Make sure not to get over spray of glue on table. Allow cement to become tacky, wait at least one minute. Stretch the pie shapes down and under the pocket opening. Press the cloth against the cement on the underside of the Play Bed. Be sure entire pie shape is fully attached to underneath side of table.

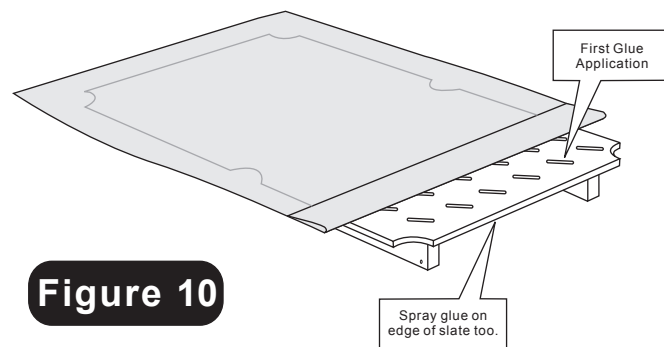

Figure 10

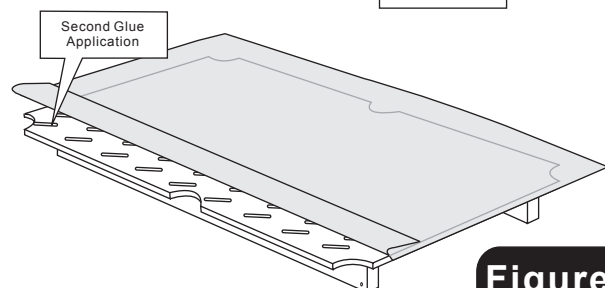

Figure 11

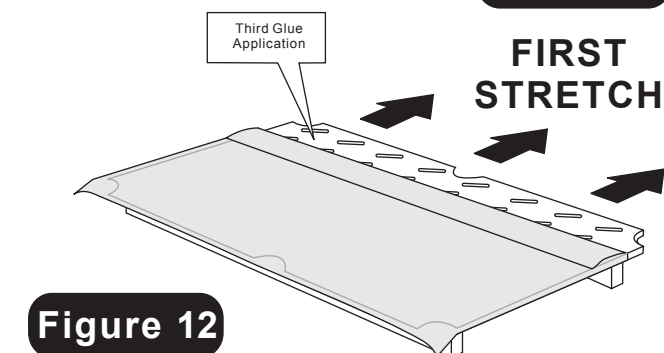

Figure 12

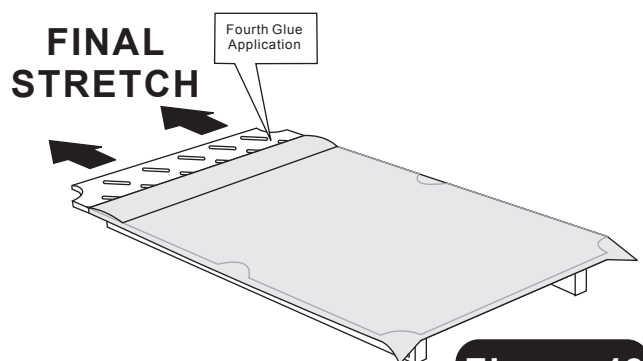

Figure 13

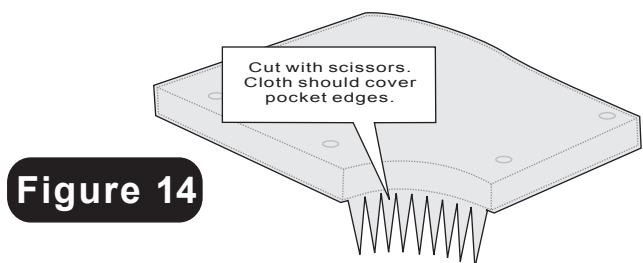
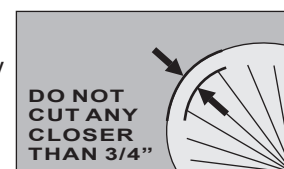
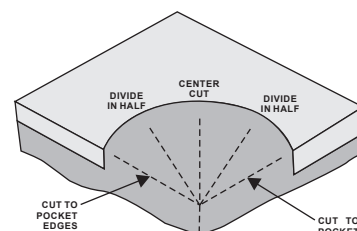

Figure 14



Detail A



Detail B

PARTS REQUIRED:
 24 pcs - **H8** Screw
 2 pcs - **P9** Side Top Rail
 2 pcs - **P10** End Top Rail
 4 pcs - **P11** Corner Cap

STEP 6:

On a clean level surface, lay each **P9** Side Top Rail and **P10** End Top Rail face down as shown in **Figure 15**. Next, lay each **P11** Corner Cap face down and attach using **H8** Screws (see inset) .

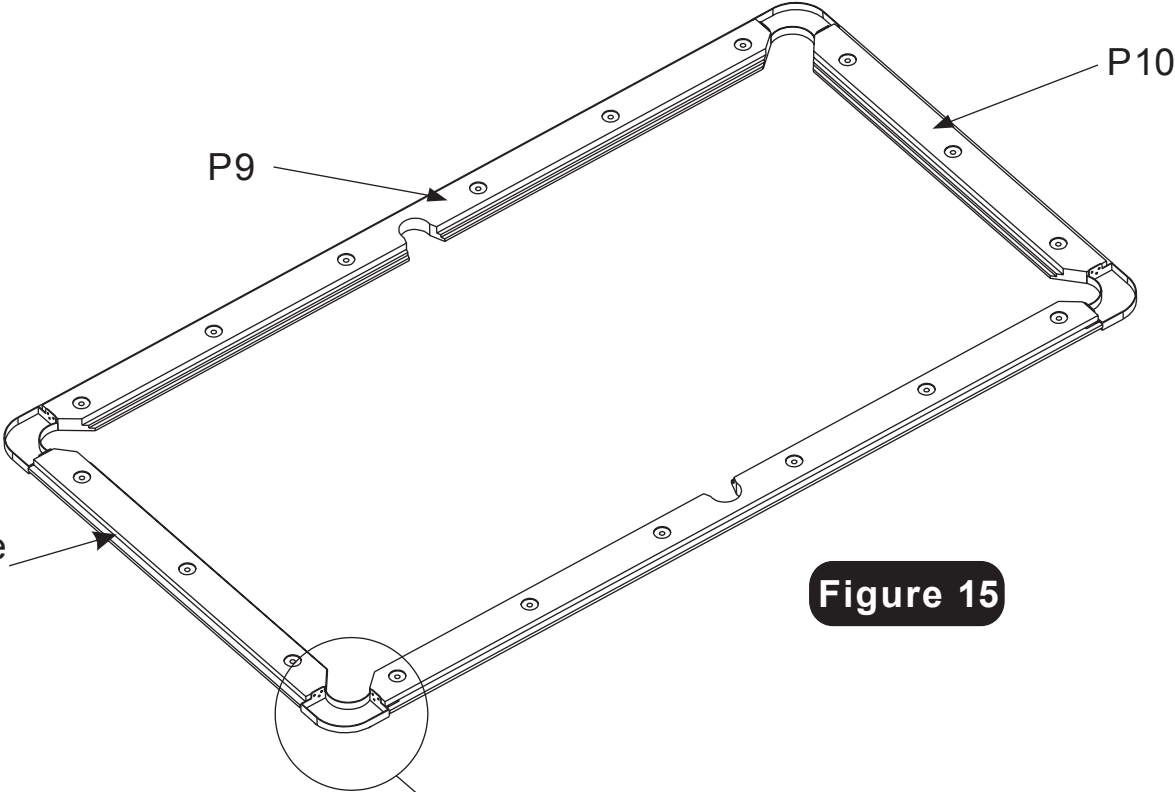

NOTE:
 All parts are upside down

Figure 15

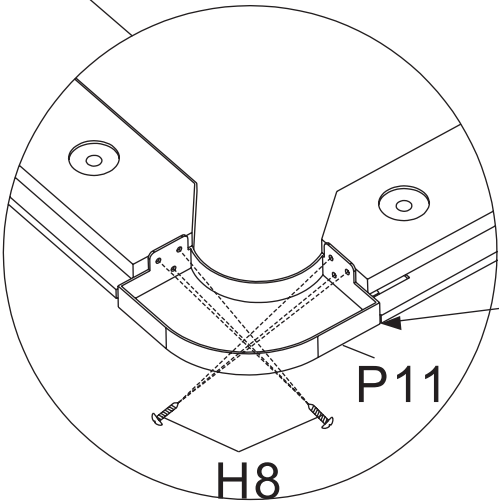

NOTE:
 Edge of Rail and Edge of Corner Cap must be flush.

PARTS REQUIRED:

12 pcs - H9 Bolt	2 pcs - P12 Side Apron
12 pcs - H10 Washer	2 pcs - P13 End Apron
24 pcs - H11 Screw	4 pcs - P14 Corner Post

STEP 7:

With the rail assembly face down, place a **P13** End Apron flush against the bottom of the **P10** End Top Rail and align using threaded inserts on the underside of each rail. Attach the end apron as shown using **H9** Bolts with **H10** washers (see inset). **Do not tighten yet.** Attach opposite **P13** End Apron. **Do not tighten yet.**

Next, slide each **P14** Corner Post over the edge of each **P13** End Apron. **Do not attach the Corner Post yet.** Next, slide one **P12** Side Apron into the Corner Post, hold flush against the rail and attach all aprons to top rails using **H9** Bolts with **H10** Washers. **Do not tighten yet.** Be sure each **P14** Corner Post is flush with each apron, then attach using **H11** Screws. Lastly, tighten all **H9** Apron Bolts.

Note:

Be sure each corner post is flush with each apron.

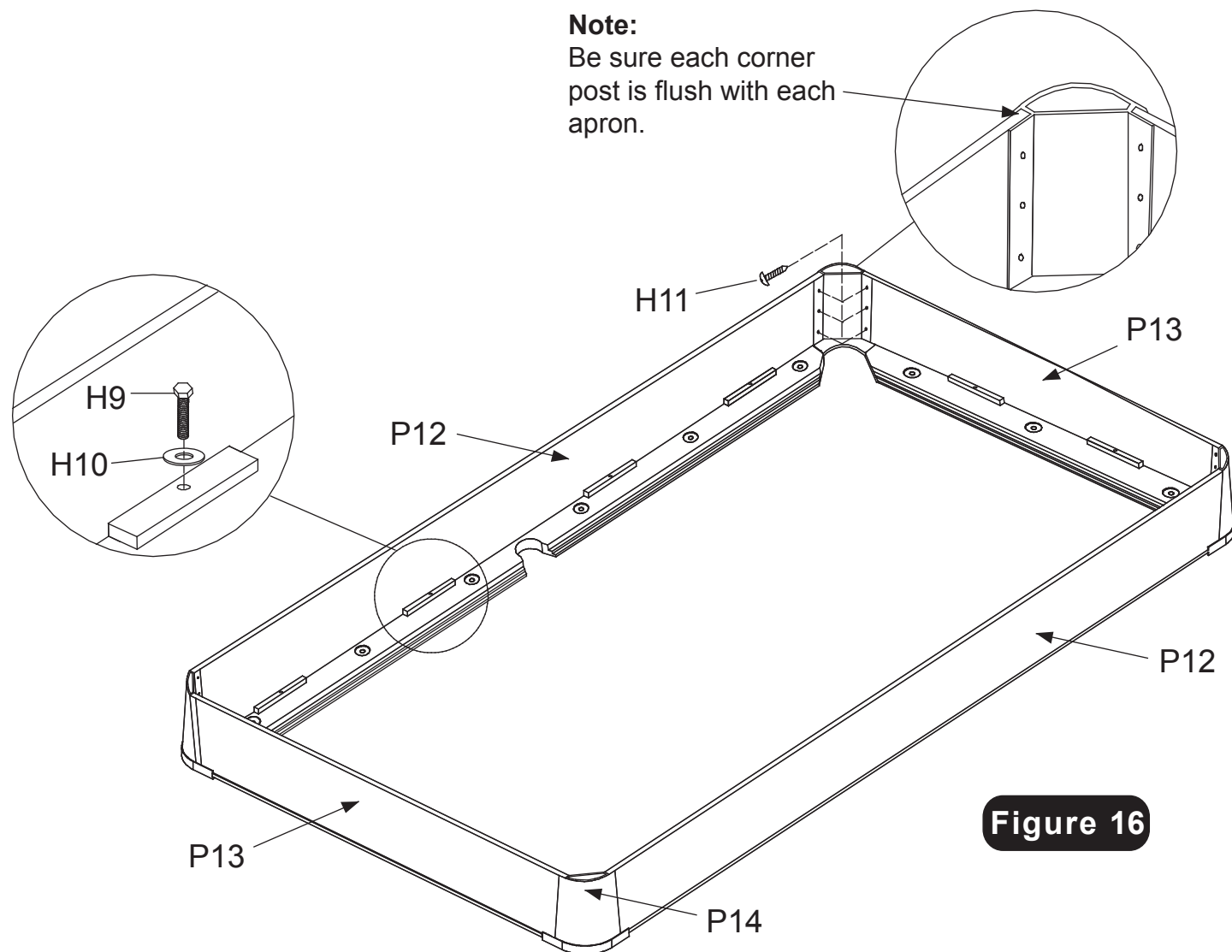

Figure 16

PARTS REQUIRED:

18 pcs - H12 Bolt

18 pcs - H13 Washer

STEP 9:

With the help of three other adults, carefully rotate the rail and apron assembly and then place over the play bed as shown. From the underside of the table, insert each H12 Bolts with H13 Washers up through the play bed and into the threaded inserts of each rail. Be sure the rail assembly is aligned with the play bed and pockets, then tighten all bolts.

Figure 17

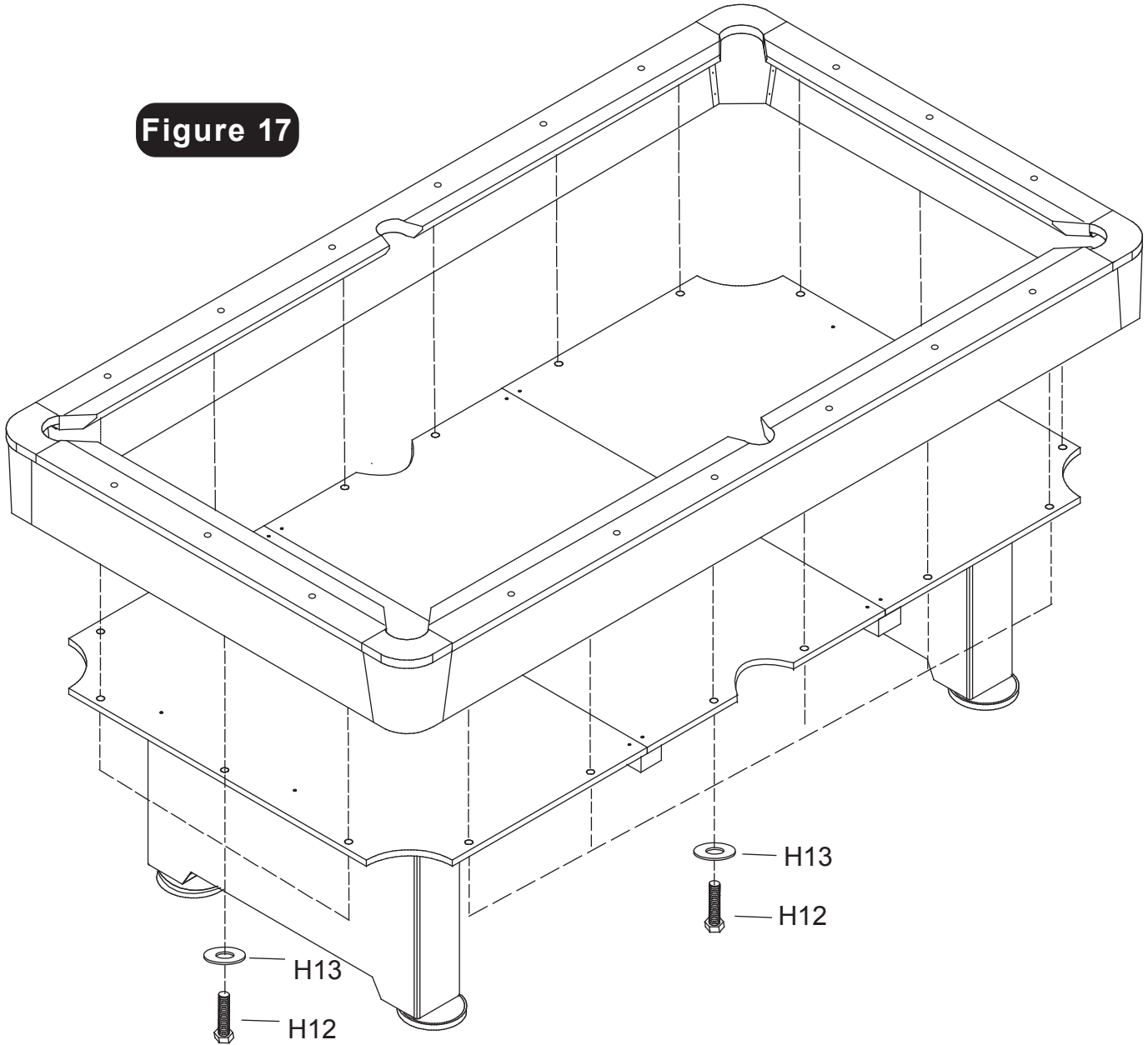

PARTS REQUIRED:

- | | |
|----------------------------------|---------------------------------|
| 24 pcs - H14 Pocket Nail | 1 pcs - A2 Triangle |
| 4 pcs - P15 Corner Pocket | 1 pcs - A3 Brush |
| 2 pcs - P16 Side Pocket | 1 set - A5 Billiard Ball |
| 2 pcs - A1 Cue Stick | 2 pcs - A6 Chalk |

STEP 10:

Insert the **P15** Corner and **P16** Side pockets into the drop pocket openings from the underside of the table. Fasten pockets using four nails **H14** per pocket. Hold the nails with needle nose pliers and tap them in with a small hammer. Once the nails have started into plastic pocket, hammer them completely into the rails until heads are flush with plastic pockets. (See **Figure 18**)

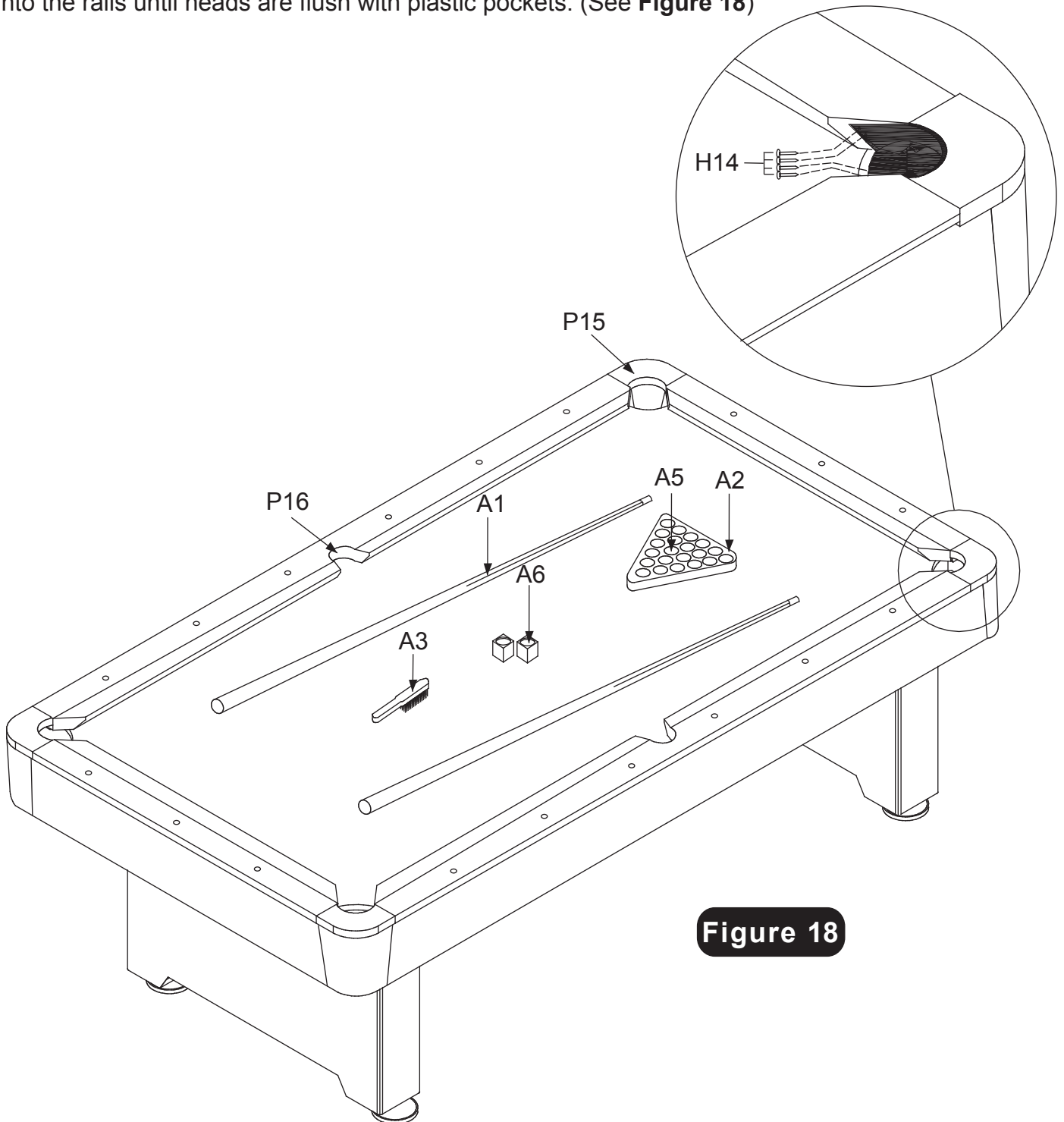

Figure 18

90 DAY LIMITED WARRANTY

This customer warranty extends to the original owner, on the purchase of any ESCALADE SPORTS Product (hereinafter referred as the "Product").

WARRANTY DURATION: This Product is warranted to the original owner, for a period of 90 days from the original purchase.

WARRANTY COVERAGE: ESCALADE SPORTS warrants to the original owner, this product to be free from defects in material and workmanship when used for the intended purpose under normal use and conditions. THIS WARRANTY IS VOID IF THE PRODUCT HAS BEEN DAMAGED BY ACCIDENT, UNREASONABLE USE, NEGLIGENCE, IMPROPER SERVICE, FAILURE TO FOLLOW INSTRUCTIONS PROVIDED WITH THE PRODUCT OR OTHER CAUSES NOT ARISING OUT OF DEFECTS IN MATERIAL AND WORKMANSHIP.

WARRANTY REPLACEMENT: During the above 90 day warranty period, ESCALADE SPORTS shall provide replacement components or replace with a comparable product at our choosing. If product is defective under normal use and proper care, please contact our Customer Service Dept.

1-866-556-2757 / Customer Service Dept.

Or Write us at:

Escalade® Sports, Inc. - P.O. Box 889, Evansville, IN 47706

Attn: Customer Service Dept.

Or E-mail us at:

customerservice@escaladesports.com

Other than shipping requirements no charge will be made for such replacement of in-warranty Products.

WARRANTY DISCLAIMERS: ANY IMPLIED WARRANTIES ARISING OUT OF THIS SALE, INCLUDING BUT NOT LIMITED TO THE IMPLIED WARRANTIES OF MERCHANTABILITY AND FITNESS FOR A PARTICULAR PURPOSE, ARE LIMITED IN DURATION TO THE ABOVE 90 DAY PERIOD. ESCALADE SPORTS SHALL NOT BE LIABLE FOR LOSS OF USE OF THE PRODUCT OR OTHER CONSEQUENTIAL OR INCIDENTAL COSTS, EXPENSES OR DAMAGES INCURRED BY THE CONSUMER OF ANY OTHER USE.

Some states do not allow the exclusion or limitation of implied warranties or consequential or incidental damages, so the above limitations or exclusions may not apply to you.

LEGAL REMEDIES: This warranty gives you specific legal rights and you may also have other rights which may vary from state to state.

Need game rules? Get rules and additional information on our website:

[Http://www.escaladesports.com/harvard-game-table/gamerules.html](http://www.escaladesports.com/harvard-game-table/gamerules.html)

PARTS LIST FOR MODEL # P5223W

PART #	KEY #	DESCRIPTION	QTY.
P5223WWJH1	H1	3/8"x2-1/4" Bolt	8
P5223WWJH2	H2	3/8" Spring Washer	16
P5223WWJH3	H3	3/8"x25mm Washer	32
P5223WWJH4	H4	3/8" Hex Nut	16
P5223WWJH5	H5	3/8"x3" Bolt	8
P5223WWJH6	H6	WP/4x1" Round Washer Head Screw	8
P5223WWJH7	H7	F5x1-3/4" Flat Head Screw	12
P5223WWJH8	H8	WP/3x18mm Round Washer Head Screw	24
P5223WWJH9	H9	5/16"x1-3/4" Bolt	12
P5223WWJH10	H10	5/16"x23 mm Washer	12
P5223WWJH 11	H11	T4x15mm Round Head Screw	24
P5223WWJH12	H12	5/16"x1-1/2" Bolt	18
P5223WWJH13	H13	5/16"x32 mm Washer	18
P5223WWJH14	H14	Pocket Nail	24
P5223WWJT 1	T1	Grout Kit	1
P5223WWJT2	T2	Spray Adhesive	1
P5223WWJT3	T3	Sand Paper	1
P5223WWJT4	T4	Wrench	1
P5223WWJA1	A1	Cue Stick	1
P5223WWJA2	A2	Triangle	1
P5223WWJA3	A3	Brush	1
P5223WWJA4	A4	Table Cloth	1
P5223WWJA5	A5	Billiard Ball	1
P5223WWJA6	A6	Chalk	2
P5223WWJP1	P1	Leg	2
P5223WWJP2	P2	Main Metal Beam	2
P5223WWJP3	P3	End Slat	2
P5223WWJP4	P4	Middle Slat	2
P5223WWJP5	P5	Main Beam End Board	4
P5223WWJP6	P6	End Play Bed Slatron (P2000W)	2
P5223WWJP6S	P6S	End Play Bed Slate (809-551)	2
P5223WWJP7	P7	Middle Play Bed Slatron (P2000W)	1
P5223WWJP7S	P7S	Middle Play Bed Slate (809-551)	1
P5223WWJP8	P8	Shim	8
P5223WWJP9	P9	Side Top Rail	2
P5223WWJP10	P10	End Top Rail	2
P5223WWJP11	P11	Corner Cap	4
P5223WWJP12	P12	Side Apron	2
P5223WWJP13	P13	End Apron	2
P5223WWJP14	P14	Corner Post	4
P5223WWJP15	P15	Corner Pocket	4
P5223WWJP16	P16	Side Pocket	2
P5223WWJP17	P17	Leg Leveler	4
P5223WWJK1	K1	Hardware Kit	1
P5223WWJM1	M1	Manual	1