

brother

# User's Guide

ADS-2000e  
ADS-2500We

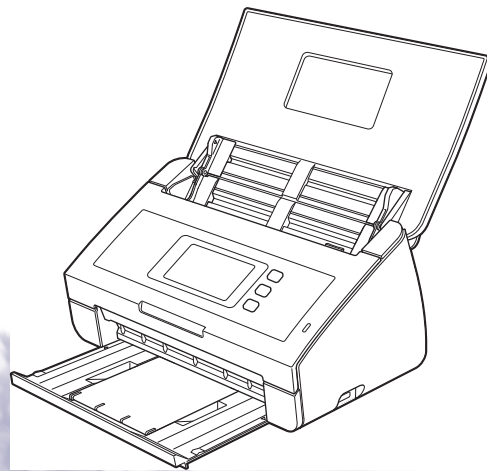

Version A  
USA

## Brother Numbers

### IMPORTANT

---

For technical help, you must call the country where you bought the machine. Calls must be made **from within** that country.

---

### Register Your Product

---

By registering your product with Brother International Corporation, you will be recorded as the original owner of the product. Your registration with Brother:

- may serve as confirmation of the purchase date of your product should you lose your receipt;
- may support an insurance claim by you in the event of product loss covered by insurance; and,
- will help us notify you of enhancements to your product and special offers.

Complete and fax the Brother Warranty Registration And Test Sheet or, for your convenience and most efficient way to register your new product, register on-line at

<http://www.brother.com/registration>

### FAQs (frequently asked questions)

---

The Brother Solutions Center is our one-stop resource for all your Brother machine needs. You can download the latest software documents and utilities, read FAQs and troubleshooting tips, and learn how to get the most from your Brother product.

<http://support.brother.com>

### NOTE

---

- You can check here for Brother driver updates.
  - To keep your machine performance up to date, check here for the latest firmware upgrade.
-

## For Customer Service

---

**In USA:** 1-877-BROTHER (1-877-276-8437)  
1-901-379-1215 (fax)

**In Canada:** <http://www.brother.ca/support>

If you have comments or suggestions, write us at:

**In USA:** Printer Customer Support  
Brother International Corporation  
200 Crossing Boulevard  
Bridgewater, NJ 08807-0911

**In Canada:** Brother International Corporation (Canada), Ltd.  
Customer Experience Team  
1, rue Hotel de Ville Dollard-des-Ormeaux, PQ, Canada H9B 3H6

### Service center locator (USA only)

For the location of a Brother authorized service center, call 1-877-BROTHER (1-877-276-8437) or visit us on-line at <http://www.brother-usa.com/service>

### Service center locations (Canada only)

For the location of a Brother authorized service center, visit us at <http://www.brother.ca/support>

#### Internet addresses

Brother Global Web Site: <http://www.brother.com>

For Frequently Asked Questions (FAQs), Product Support and Technical Questions, Driver Updates and Utilities, and User's Guides: <http://support.brother.com>

For Brother Accessories & Supplies:

In USA: <http://www.brothermall.com>

In Canada: <http://www.brother.ca>

## User's Guides and where do I find them?

Which manual?	What's in it?	Where is it?
<b>Quick Setup Guide</b> <b>Product Safety Guide</b>	<p>Follow the instructions for setting up your machine and installing the drivers and software for the operating system and connection type you are using.</p> <p>This Guide also includes the Safety Instructions before you set up your machine. Read the instructions first.</p>	Printed / In the box
<b>User's Guide</b>	Learn the Scan operations and security features, learn how to perform routine maintenance, and see troubleshooting tips.	PDF file / Brother Solutions Center <sup>1</sup>
<b>Network User's Guide</b> (ADS-2500We only)	This Guide provides useful information about Ethernet network settings and security settings using the Brother machine. You can also find supported protocol information for your machine and detailed troubleshooting tips.	PDF file / Brother Solutions Center <sup>1</sup>
<b>Web Connect Guide</b> (ADS-2500We only)	This Guide provides useful information about accessing internet services from the Brother machine, as well as downloading images and uploading files directly from internet services.	PDF file / Brother Solutions Center <sup>1</sup>
<b>Mobile Print/Scan Guide for Brother iPrint&amp;Scan</b> (ADS-2500We only)	This Guide provides useful information about scanning from your Brother machine to your mobile device when connected to a Wi-Fi network. For more information on Printing using this app to devices supporting print refer to the guide.	PDF file / Brother Solutions Center <sup>1</sup>
<b>Brother Image Viewer Guide for Android™</b>	This Guide provides useful information about using your Android™ mobile device to view and edit documents that were scanned by a Brother machine.	PDF file / Brother Solutions Center <sup>1</sup>
<b>Brother ScanViewer Guide for iOS/OS X</b>	This Guide provides useful information about using your iOS device or Macintosh computer to view and edit documents that were scanned by a Brother machine and saved to iCloud.	PDF file / Brother Solutions Center <sup>1</sup>

<sup>1</sup> Visit us at <http://support.brother.com>

# Getting Started

Features		Applications	What Can I Do?	Where Should I Go for More Information?
Scan to PC	Scan to Image	ControlCenter4 (Windows®) ControlCenter2 (Macintosh)	Scan your document directly into a graphics application for image editing.	For scanning from the Control Panel of the machine: <i>Save Scanned Documents on Your Computer</i> on page 120
	Scan to OCR			For scanning from ControlCenter4 (Windows®): <ul style="list-style-type: none"> <li>■ Home Mode: <i>Basic Scan</i> on page 50</li> <li>■ Advanced Mode: <i>Basic Scan</i> on page 58</li> </ul> For scanning from ControlCenter2 (Macintosh): <i>Scan to Image</i> on page 74
			Scan your document and convert it to text. This text can be edited using your favorite word processing software.	For scanning from the Control Panel of the machine: <i>Save Scanned Documents on Your Computer</i> on page 120
				For scanning from ControlCenter4 (Windows®): <ul style="list-style-type: none"> <li>■ Home Mode: <i>Basic Scan</i> on page 50</li> <li>■ Advanced Mode: <i>Basic Scan</i> on page 58</li> </ul> For scanning from ControlCenter2 (Macintosh): <i>Scan to OCR</i> on page 75

Features		Applications	What Can I Do?	Where Should I Go for More Information?
Scan to PC (continued)	Scan to email	ControlCenter4 (Windows®)  ControlCenter2 (Macintosh)  (continued)	Scan your document to your default email application, so you can send the scanned job as an attachment.	<p>For scanning from the Control Panel of the machine: <i>Save Scanned Documents on Your Computer</i> on page 120</p> <p>For scanning from ControlCenter4 (Windows®):</p> <ul style="list-style-type: none"> <li>■ Home Mode: <i>Basic Scan</i> on page 50</li> <li>■ Advanced Mode: <i>Basic Scan</i> on page 58</li> </ul> <p>For scanning from ControlCenter2 (Macintosh): <i>Scan to E-mail</i> on page 76</p>
	Scan to File		Scan your document and save it to a folder on your hard disk in one of the file types shown in the file type list. If you want to scan your document as a PDF file, select this method.	<p>For scanning from the Control Panel of the machine: <i>Save Scanned Documents on Your Computer</i> on page 120</p> <p>For scanning from ControlCenter4 (Windows®):</p> <ul style="list-style-type: none"> <li>■ Home Mode: <i>Basic Scan</i> on page 50</li> <li>■ Advanced Mode: <i>Basic Scan</i> on page 58</li> </ul> <p>For scanning from ControlCenter2 (Macintosh): <i>Scan to File</i> on page 77</p>

Features		Applications	What Can I Do?	Where Should I Go for More Information?
Scan to PC (continued)	Scan Business Cards	NewSoft Presto! BizCard 6 (Windows® and Macintosh)	Use the NewSoft Presto! BizCard 6 application included in the Brother MFL-Pro software suite for scanning business cards.	Use <i>NewSoft Presto! BizCard 6 (Windows®)</i> on page 108  Use <i>NewSoft Presto! BizCard 6 (Macintosh)</i> on page 118
	Scan Using the TWAIN/WIA/ISIS® Driver for Windows® Users	Applications supporting TWAIN/WIA/ISIS driver such as:  Nuance™ PaperPort™ 12SE  Windows® Fax and Scan  Windows® Photo Gallery  Captiva® QuickScan™ Pro	Use the Nuance™ PaperPort™ 12SE application included in the Brother MFL-Pro software suite, or other applications supporting TWAIN or WIA specifications, for scanning.  You can also use the free trial version of Captiva® QuickScan™ Pro, or other applications supporting ISIS® specifications, for scanning. Before scanning using the ISIS® applications, you must install the ISIS® scanner driver.	For scanning using the TWAIN/WIA driver:  <i>Scan Using Nuance™ PaperPort™ 12SE or Other Windows® Applications</i> on page 96  For scanning using the ISIS® driver:  <i>Scan Using Captiva® QuickScan™ Pro or ISIS® Applications (Windows®)</i> on page 119
	Scan Using the TWAIN/ICA Driver for Macintosh Users	Applications supporting TWAIN/ICA driver such as:  Presto! PageManager  Apple Image Capture	Use the Presto! PageManager application included in the Brother MFL-Pro software suite, or other applications supporting TWAIN specifications, for scanning.  After installing the Brother MFL-Pro software suite, you can also use the Apple Image Capture application for scanning.	For scanning using the TWAIN driver:  <i>Scan Using Presto! PageManager or TWAIN Applications (Macintosh)</i> on page 109  For scanning using the ICA driver:  <i>Scan Using Apple Image Capture (ICA Driver)</i> on page 114
	WS Scan (Windows® users only) (ADS-2500We only)	Windows® Fax and Scan  Windows® Photo Gallery	Scan your document by using the Web Services protocol. The Web Services protocol enables you to scan over the network using your machine and a computer running Windows Vista® (SP2 or later), Windows® 7, Windows® 8 or Windows® 8.1.	For installing drivers:  <i>Install Drivers Used for Scanning via Web Services (Windows Vista®, Windows® 7, Windows® 8, Windows® 8.1)</i> in the <i>Network User's Guide</i>  For scanning from the Control Panel of the machine:  <i>Scan Using Web Services (Windows Vista® SP2 or Later, Windows® 7, Windows® 8 and Windows® 8.1) (ADS-2500We)</i> on page 138

Features		Applications	What Can I Do?	Where Should I Go for More Information?
Scan from the Control Panel of the Machine	Scan to USB	—	Scan your document and save the scanned image on a USB flash drive. You can configure the settings on the control panel of the machine.	<i>Save Scanned Documents on a USB Flash Drive</i> on page 123
	Scan to FTP (ADS-2500We only)		Scan your document directly to an FTP server on your local network, or on the internet.	<i>Scan Documents to an FTP Server (ADS-2500We only)</i> on page 128
	Scan to Network (Windows® users only) (ADS-2500We only)		Scan your document directly to a shared folder on your local network, or on the internet.	<i>Scan Documents to a Shared Folder / Network Location (Windows®) (ADS-2500We only)</i> on page 134
	Scan to email Server (ADS-2500We only)	—	Scan your document and send it directly to an email address from the machine. In addition, because this feature can assign an email address to the machine, you can use the machine to send documents over your local network or the internet to computers or other Internet Fax machines.	<i>Send Scanned Documents Directly to an Email Address (ADS-2500We only)</i> on page 140
	Scan to Web (ADS-2500We only)		Scan your document and upload it directly to Web Services, such as Evernote, Dropbox, Box and OneDrive, without using a computer.	Web Connect Guide

Features		Applications	What Can I Do?	Where Should I Go for More Information?
From Mobile Devices	Scan Documents (Brother iPrint&Scan)	Brother iPrint&Scan	Scan your document directly from your Android™ devices, iOS devices, and Windows® Phone without using a computer.  You can download and install Brother iPrint&Scan from the Google Play, App Store, or Windows® Phone Store.	Mobile Print/Scan Guide for Brother iPrint&Scan
	View or Edit Scanned Data (iOS/OS X) (ADS-2500We only)	Brother ScanViewer	Use your iOS device or Macintosh computer to view and edit images and documents that were scanned by a Brother machine and saved to iCloud.  You can download and install Brother ScanViewer from the App Store.	Brother ScanViewer Guide for iOS/OS X
	View or Edit Scanned Data (Android™) (ADS-2500We only)	Brother Image Viewer	Use your Android™ mobile device to view and edit documents that were scanned by a Brother machine.  You can download and install Brother Image Viewer from the Google Play.	Brother Image Viewer Guide for Android™

# Table of Contents

<b>1</b>	<b>General Information</b>	<b>1</b>
	Using the Documentation .....	1
	Symbols and Conventions Used in the Documentation .....	1
	About This Machine .....	2
	Control Panel Overview (ADS-2000e) .....	3
	Control Panel Overview (ADS-2500We).....	4
	Touchscreen LCD.....	5
	Basic LCD Operations .....	8
	General Setup (ADS-2000e).....	9
	Set Sleep Mode .....	9
	Select Your Language .....	11
	Reduced Noise Mode .....	13
	General Setup (ADS-2500We) .....	14
	Set the Backlight Brightness.....	14
	Set the Dim Timer for the Backlight.....	14
	Set the Home Screen .....	14
	Select Your Language .....	15
	Memory Storage .....	15
	Beep Volume .....	15
	Automatic Daylight Saving Time.....	16
	Sleep Mode .....	16
	Power Down Mode .....	17
	Multifeed Detection.....	17
	Reduced Noise Mode .....	18
	Setting Lock.....	18
	Set the Password .....	19
	Change the Password .....	19
	Turn Setting Lock On/Off.....	20
	User Restriction Functions .....	21
<b>2</b>	<b>Document Specifications</b>	<b>24</b>
	Acceptable Documents.....	24
	Unacceptable Documents.....	26
	Carrier Sheet Recommendations .....	27
	Notes for Using Carrier Sheets.....	28
<b>3</b>	<b>Scan Preparation</b>	<b>29</b>
	Set Up Your Scanner.....	29
	Load Documents.....	30
	Standard-size Documents .....	30
	Business Cards and Plastic Cards .....	32
	Documents Longer than Standard-size .....	33
	Documents not printed on standard-size paper.....	34
	Documents with Facing Pages .....	35
	Receipts, Clippings, Photos, and Other Documents .....	35

**4 Prepare Your Network 37**

Before Scanning .....37  
Before Network Scanning (ADS-2500We only) .....38  
    Network License (Windows®).....38  
    Configure Network Scanning for Windows® .....38  
    Configure Network Scanning for Macintosh .....42  
    Launch the BRAdmin Utility (Windows®) .....45

**5 Scan Using Your Computer 46**

Change the ControlCenter4 User Interface (Windows®).....46  
Scan Using ControlCenter4 in Home Mode (Windows®) .....50  
    Basic Scan.....50  
    Scan Documents Using the Carrier Sheet.....51  
    Scan Plastic Cards .....53  
    Scan to an Office File .....55  
    Scan Business Cards .....56  
Scan Using ControlCenter4 in Advanced Mode (Windows®).....58  
    Basic Scan.....58  
    Change a Scan Button's Default Settings .....59  
    Scan Using the Carrier Sheet.....59  
    Scan Plastic Cards .....60  
    Scan to an Office File .....62  
    Scan Business Cards .....63  
Create a Custom Tab (ControlCenter4 Advanced Mode) (Windows®) .....65  
    Create a Custom Tab .....65  
    Create a Custom Button in a Custom Tab.....66  
Change Scan Settings (ControlCenter4) (Windows®).....67  
Scan Using ControlCenter2 (Macintosh) .....73  
    Scan to Image .....74  
    Scan to OCR .....75  
    Scan to E-mail .....76  
    Scan to File.....77  
    Change a Scan Button's Default Settings .....78  
    Scan Specific and Irregular Sized Documents Using the Carrier Sheet.....78  
    Scan Plastic Cards .....80  
    Scan to an Office File .....82  
    Scan Business Cards .....83  
Register Your Favorite Scan Settings Using ControlCenter2 (Macintosh) .....85  
    User-defined Button.....86  
Change Scan Settings (ControlCenter2) (Macintosh) .....89  
Scan Using Nuance™ PaperPort™ 12SE or Other Windows® Applications .....96  
    Scan Using Nuance™ PaperPort™ 12SE.....96  
    Scan Using Windows® Photo Gallery or Windows® Fax and Scan .....106  
Use Nuance PDF Converter Professional 8 (Windows®).....107  
    Installing Nuance PDF Converter Professional 8 .....107  
Use NewSoft Presto! BizCard 6 (Windows®) .....108  
    Installing NewSoft Presto! BizCard 6.....108  
Scan Using Presto! PageManager or TWAIN Applications (Macintosh) .....109  
    Installing Presto! PageManager .....109  
    Scan Using Presto! PageManager .....109  
    TWAIN Driver Settings .....111

Scan Using Apple Image Capture (ICA Driver) .....	114
Scan Using Apple Image Capture .....	114
ICA Driver Settings .....	116
Select your machine from Print & Fax or Print & Scan .....	117
Use NewSoft Presto! BizCard 6 (Macintosh).....	118
Installing NewSoft Presto! BizCard 6.....	118
Scan Using Captiva® QuickScan™ Pro or ISIS® Applications (Windows®).....	119
Installing ISIS® Scanner and Captiva® QuickScan™ Pro .....	119

---

## **6 Scan Using the Control Panel 120**

Save Scanned Documents on Your Computer.....	120
Save Scanned Documents on a USB Flash Drive.....	123
Save Scanned Documents on Mobile Devices.....	126
Scan Documents to an FTP Server (ADS-2500We only).....	128
Start Web Based Management .....	128
Configure the FTP Default Settings.....	130
Scan Using FTP Server Profiles.....	133
Scan Documents to a Shared Folder / Network Location (Windows®) (ADS-2500We only) .....	134
Configure the Scan to Network Default Settings .....	135
Scan Using Scan to Network Profiles.....	137
Scan Using Web Services (Windows Vista® SP2 or Later, Windows® 7, Windows® 8 and Windows® 8.1) (ADS-2500We).....	138
Configuring Settings for Scanning.....	138
Send Scanned Documents Directly to an Email Address (ADS-2500We only).....	140
Select an email Address from the Address Book .....	140
Enter an email Address Manually.....	141
Set Up the Address Book (ADS-2500We only) .....	142
Register an email Address .....	142
Change an email Address .....	142
Delete an email Address .....	143
Set Up a Group.....	144
Change a Group .....	144
Delete a Group .....	145
Upload Scanned Documents to the Web (ADS-2500We only).....	146
Change Scan to PC Settings (Windows®) .....	147
Change Scan to PC Settings (Macintosh) .....	154
Scanner Shortcuts (ADS-2500We only).....	160
Add a Shortcut.....	160
Edit, Rename or Delete a Shortcut.....	161

---

## **7 Managing the Machine from Your Computer 162**

Monitor the Machine's Status from Your Computer (Windows®) .....	162
Error Notifications.....	163
Status Monitor Indicators.....	163
Monitor the Machine's Status from Your Computer (Macintosh).....	164
Turn the AutoLoad Feature On/Off (ControlCenter2).....	166
Set Up the Brother Machine from Your Computer.....	167

<b>8</b>	<b>Routine Maintenance</b>	<b>171</b>
	Clean the Outside of the Machine .....	171
	Clean the Scanner .....	173
	Replace Supplies .....	179
	Part Names, Numbers, and Life Cycles .....	179
	Check Supplies Replacement Cycle (ADS-2000e) .....	181
	Check Supplies Replacement Cycle (ADS-2500We) .....	182
	Replace the Separation Pad .....	183
	Replace the Pick-up Roller .....	185
	Reset the Usage Counters (ADS-2000e) .....	188
	Reset the Usage Counters (ADS-2500We) .....	189
	Packing and Shipping the Machine .....	190
<b>9</b>	<b>Troubleshooting</b>	<b>192</b>
	Identify Your Problem .....	192
	Error and Maintenance Messages .....	192
	Document Jam .....	195
	Long Paper Jam .....	197
	Troubleshooting .....	198
	If you are having difficulty with your machine .....	198
	Machine Information .....	204
	Check the Serial Number (ADS-2000e) .....	204
	Check the Serial Number (ADS-2500We) .....	205
	WLAN Enable/Disable (ADS-2500We only) .....	206
	Reset Functions .....	206
	Reset the Machine (ADS-2500We only) .....	206
<b>A</b>	<b>Specifications</b>	<b>207</b>
	General .....	207
	Scanner .....	209
	Direct Scan Feature (Scan to USB) .....	209
	Interfaces .....	210
	Network (ADS-2500We only) .....	210
	Computer Requirements .....	211
<b>B</b>	<b>Appendix</b>	<b>212</b>
	Entering Text (ADS-2500We only) .....	212
	Inserting spaces .....	212
	Making corrections .....	212
	LED Indications (ADS-2000e only) .....	213
	Service Call Indications .....	221
<b>C</b>	<b>Index</b>	<b>223</b>

## Using the Documentation

Thank you for buying a Brother machine! Reading the documentation will help you make the most of your machine.

### Symbols and Conventions Used in the Documentation

---

The following symbols and conventions are used throughout the documentation.

 <b>CAUTION</b>	<u>CAUTION</u> indicates a potentially hazardous situation which, if not avoided, may result in minor or moderate injuries.
<b>IMPORTANT</b>	<u>IMPORTANT</u> indicates a potentially hazardous situation which, if not avoided, may result in damage to property or loss of product functionality.
<b>NOTE</b>	<u>Notes</u> tell you how you should respond to a situation that may arise or give tips about how the operation works with other features.
<b>Bold</b>	Bold typeface identifies keys on the machine control panel or computer screen.
<i>Italics</i>	Italicized typeface emphasizes an important point or refers you to a related topic.
Courier New (ADS-2500We only)	Text in Courier New font identifies messages on the LCD of the machine.

### NOTE

---

- Unless otherwise specified, screens and illustrations in this guide show the ADS-2500We.
  - Unless otherwise specified, the screens in this manual are from Windows® 7 and OS X v10.7.5. Screens on your computer may vary depending on your operating system.
-

## About This Machine

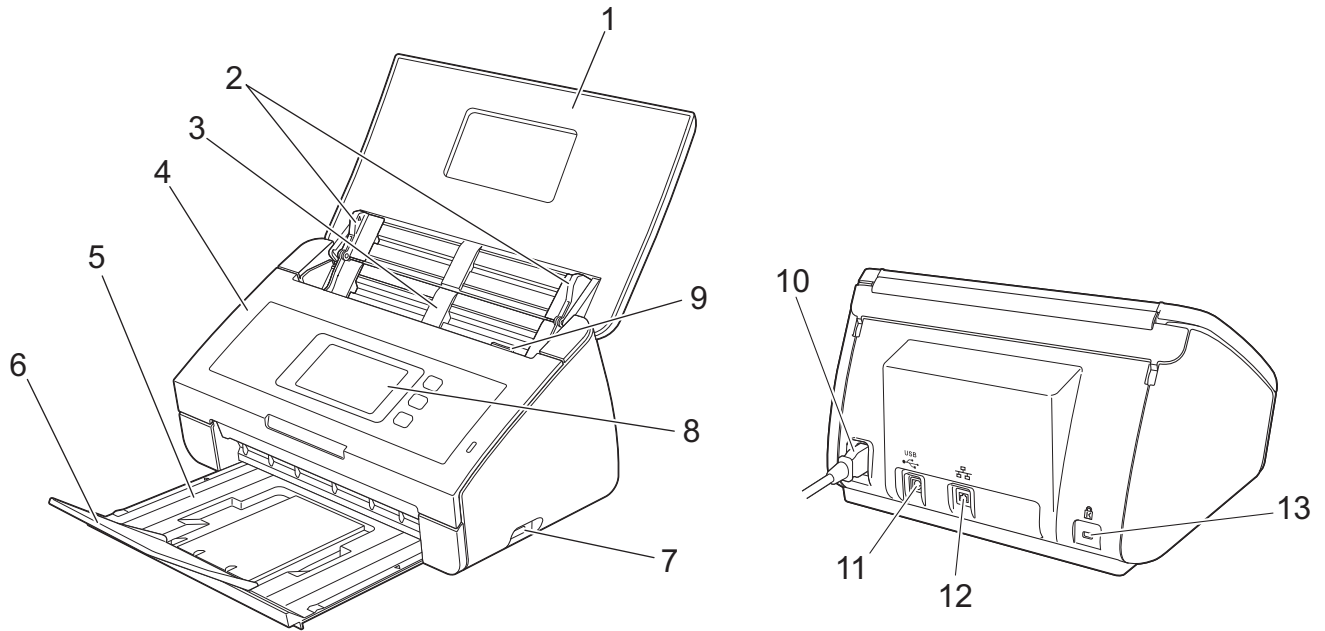

**1 Top Cover**

Turn on your machine by opening the Top Cover.

**2 Document Guides**

**3 Automatic Document Feeder (ADF)**

**4 Front Cover**

**5 Output Tray**

**6 Document Stopper**

**7 USB port**

**8 Control Panel (ADS-2500We only)**

**9 Cover Release Lever**

**10 AC Power Connector**

**11 USB Connector**

**12 LAN Connector (ADS-2500We only)**

**13 Kensington Security Slot**

## Control Panel Overview (ADS-2000e)

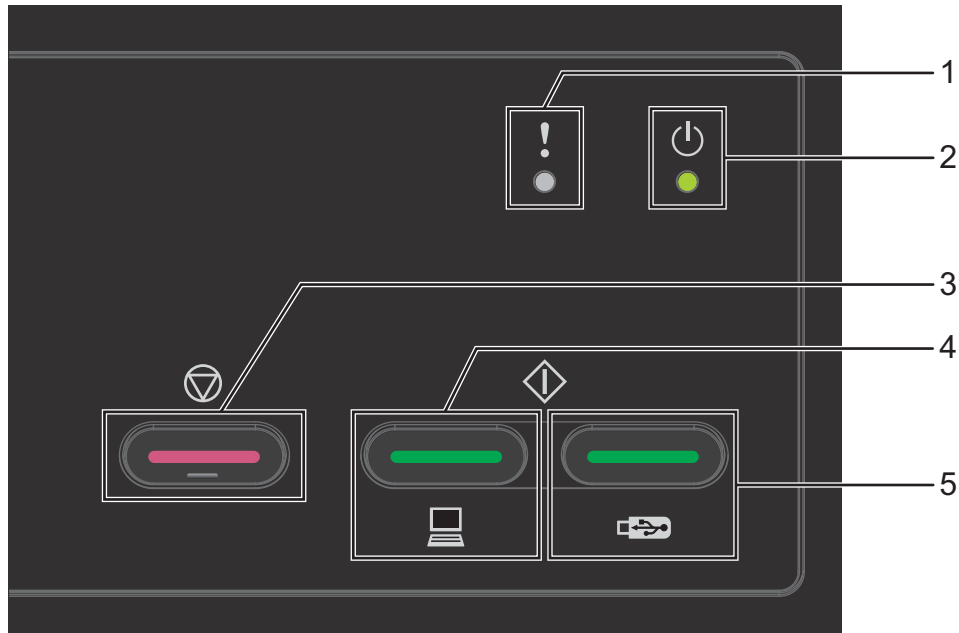

### 1 Error Indicator (with LED)

The Error Indicator indicates that the machine is in an error state, see *LED Indications (ADS-2000e only)* on page 213.

### 2 Power Indicator (with LED)

The Power Indicator blinks depending on the status of the machine.

### 3 Stop button

Press the Stop button to:

- Job Cancel
- Wake-up
- Error Recovery
- Disconnect Remote Setup

### 4 Scan to PC button (with LED)

Press the Scan to PC button to:

- Scan to PC
- Wake-up

### 5 Scan to USB button (with LED)

Press the Scan USB button to:

- Scan to USB
- Wake-up

## Control Panel Overview (ADS-2500We)

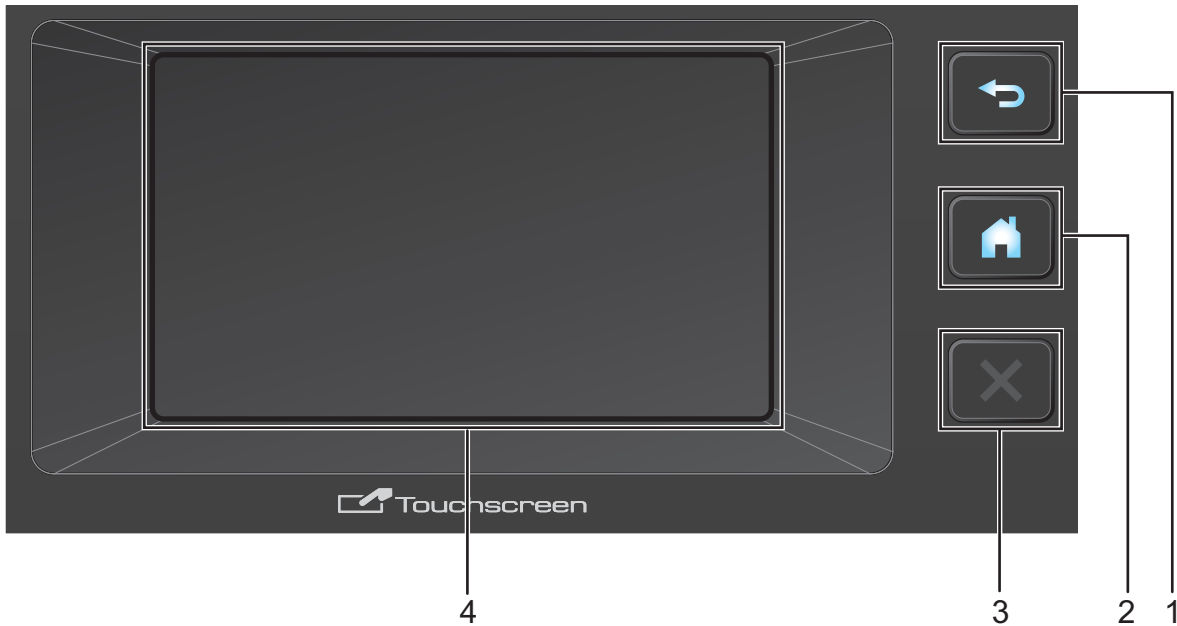

### 1 Back Button

Press to go back to the previous screen or menu. The Back button does not light up when it is unavailable.

### 2 Home Button

Press to return to the Home Screen and Ready Mode. The Home button does not light up when it is unavailable.

### 3 Stop Button

Press to stop or cancel your current action and return to Ready Mode. The Stop button does not light up when it is unavailable.

### 4 Touchscreen LCD

Access the menus and options by pressing the Touchscreen.

## Touchscreen LCD

Change the Home Screen by swiping left or right, or pressing ◀ or ▶ on the LCD. You can set a default Home screen if needed. See *Set the Home Screen* on page 14.

### Clock Mode

The LCD displays Clock Mode when the machine is idle. Clock Mode displays the date, time and current machine status.

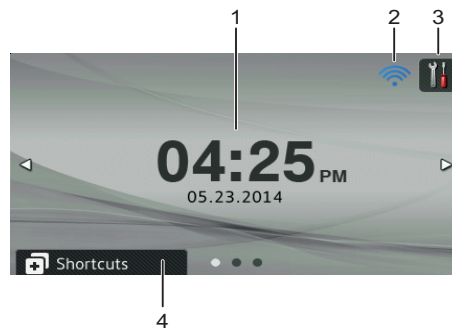

#### 1 Date and Time

Current date and current time.

#### 2

When WLAN is enabled, a four-level indicator shows the current wireless signal strength if you are using a wireless connection.



#### 3

Press to access all settings.

The information icon  appears on the Touchscreen when there is an error or maintenance message. For more information, see *Error and Maintenance Messages* on page 192.

#### 4 Shortcuts

Press to set up shortcuts. Once you have set up shortcuts, press to view all of your shortcut options.



#### 5 Scan

Press to access the Scan Mode.

## Scan Mode

The LCD displays the current machine status when the machine is idle.

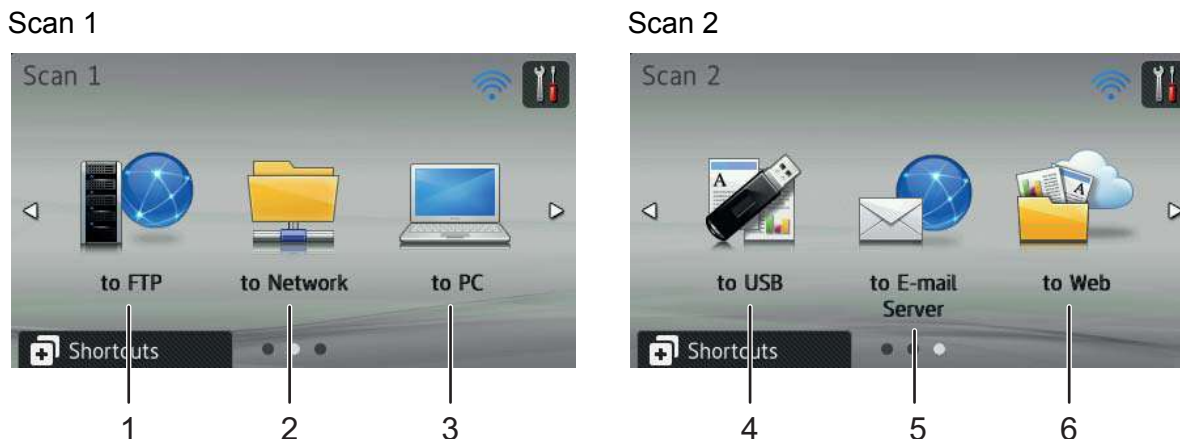

- 1 to FTP**  
Press to access the Scan to FTP function.
- 2 to Network**  
Press to access the Scan to Network function.
- 3 to PC**  
Press to access the Scan to PC function.
- 4 to USB**  
Press to access the Scan to USB function.
- 5 to E-mail Server**  
Press to access the Scan to E-mail Server function.
- 6 to Web**  
Press to access the Scan to Web function.

The information icon  appears on the Touchscreen when there is an error or maintenance message. For details, see *Error and Maintenance Messages* on page 192.

### NOTE

- This product adopts the font of ARPHIC TECHNOLOGY CO., LTD.
- MascotCapsule UI Framework and MascotCapsule Tangible developed by HI CORPORATION are used. MascotCapsule is a registered trademark of HI CORPORATION in Japan.



## Basic LCD Operations

---

To operate the LCD, use your finger to press the icon or option you want. To display and access all menus or options, swipe left or right, or press ▲ or ▼ to scroll through them.

### IMPORTANT

---

DO NOT press the LCD with a sharp object, such as a pen or stylus. It may damage the machine.

---

The following example shows how to change a machine setting. In this example, the Document Size setting in Scan to USB is changed to Auto.

- 1 Swipe left or right, or press ◀ or ▶ to display Scan 2.
- 2 Press to USB.
- 3 Press Options.
- 4 Press ▲ or ▼ to display Document Size.
- 5 Press Document Size.
- 6 Press ▲ or ▼ to display Auto.
- 7 Press Auto.

### NOTE

---

Press  to go back to the previous screen or menu.

---

# General Setup (ADS-2000e)

## Set Sleep Mode

- 1 Start the ControlCenter application.
  - Windows®
    - 1 Click the  (ControlCenter4) icon in the task tray and then select **Open** from the menu. The **ControlCenter4** window appears.
    - 2 Click the **Device Settings** tab (the example below uses **Home Mode**).

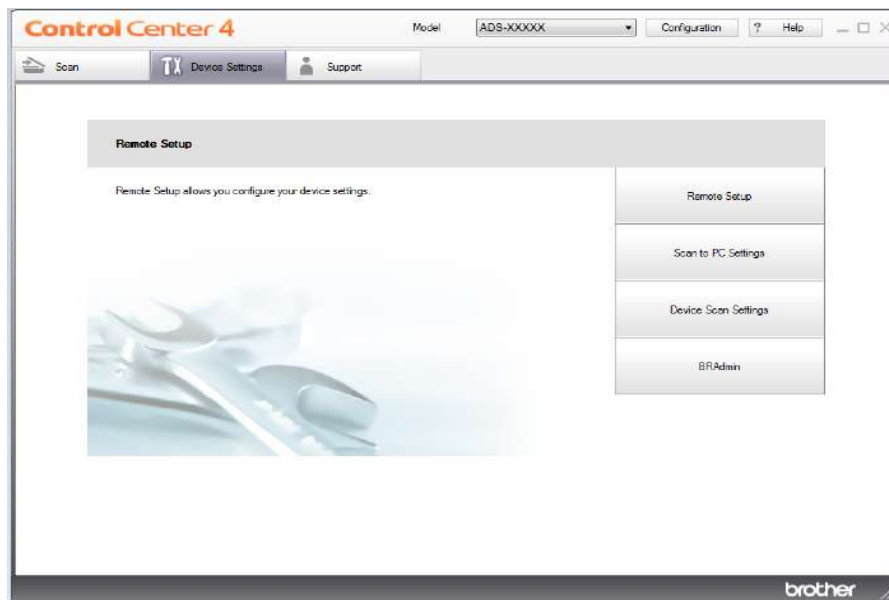

- Macintosh

- 1 Click the  (ControlCenter2) icon in the Dock. The **ControlCenter2** window appears.

- 2 Click the **DEVICE SETTINGS** tab.



- 2 Click the **Remote Setup** button. The Remote Setup window appears.

**NOTE**

For more information about **Remote Setup**, see *Set Up the Brother Machine from Your Computer* on page 167.

- 3 Select **General Setup** in the folder tree (the example below uses Windows®).

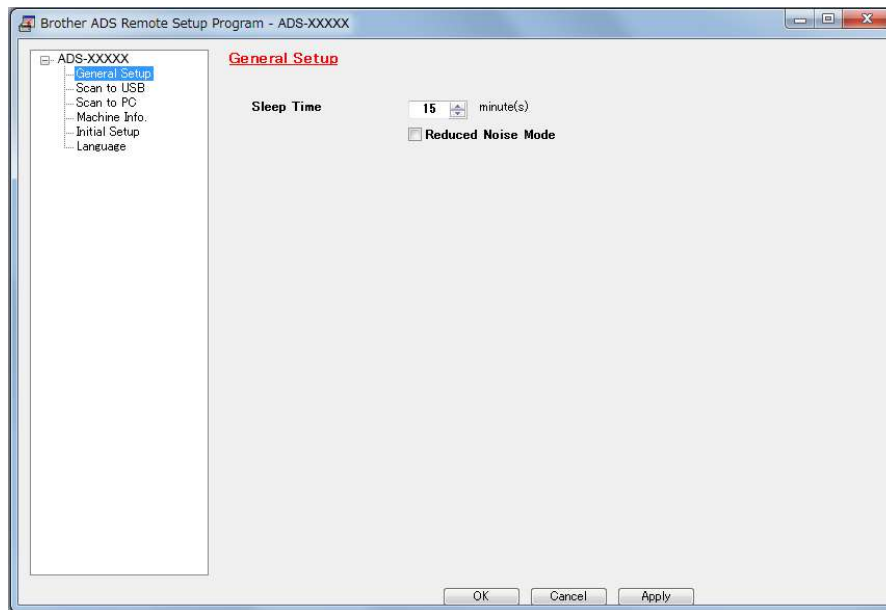

- 4 Select how long the machine must be idle before it goes into Sleep Mode.  
To exit Sleep Mode, do one of the following:
  - Press any key.
  - Open the Top Cover.
  - Load your document.

- 5 Click **OK**.

## Select Your Language

- 1 Start the ControlCenter application.
  - Windows®
- 1 Click the  (ControlCenter4) icon in the task tray and then select **Open** from the menu. The **ControlCenter4** window appears.
- 2 Click the **Device Settings** tab (the example below uses **Home Mode**).

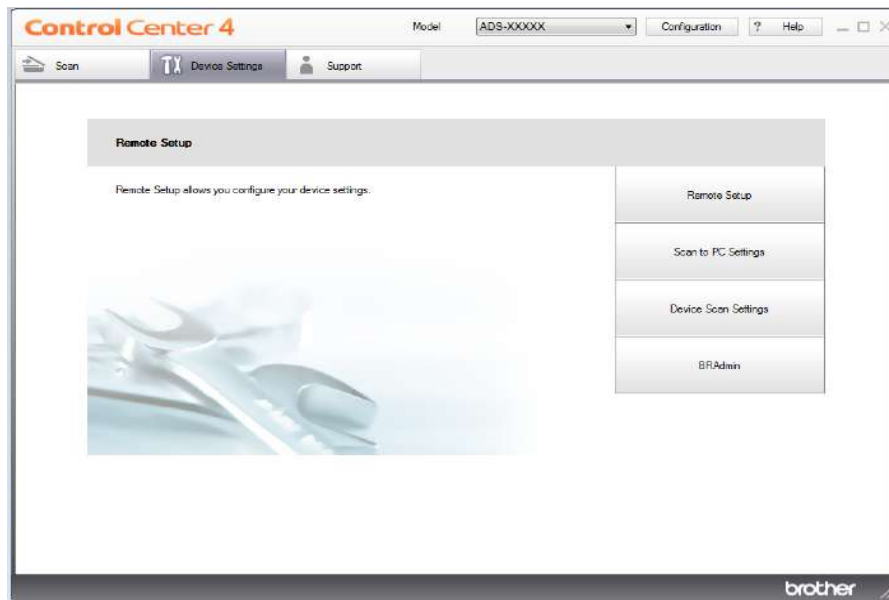

- Macintosh

- 1 Click the  (ControlCenter2) icon in the Dock. The **ControlCenter2** window appears.
- 2 Click the **DEVICE SETTINGS** tab.



- 2 Click the **Remote Setup** button. The Remote Setup window appears.

- 3 Select **Language** in the folder tree (the example below uses Windows®).

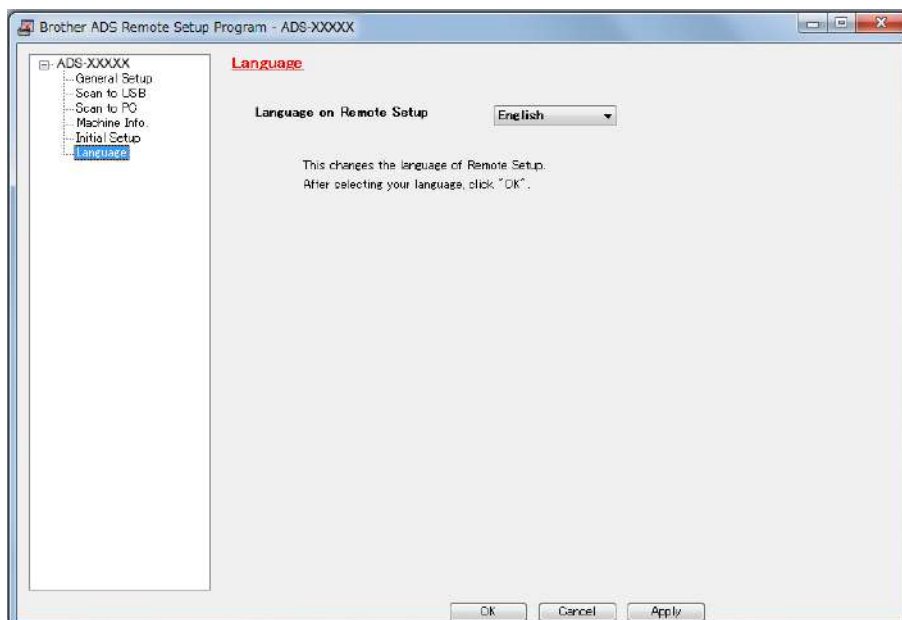

- 4 Select a language from the **Language on Remote Setup** drop-down list.
- 5 Click **OK**.

**NOTE**

You must close the Remote Setup window to save the language change.

## Reduced Noise Mode

Select the **Reduced Noise Mode** check box in Remote Setup to reduce acoustic noise while scanning. Reducing noise may slow scan speed.

To start Remote Setup, see *Set Up the Brother Machine from Your Computer* on page 167 (the example below uses Windows®).

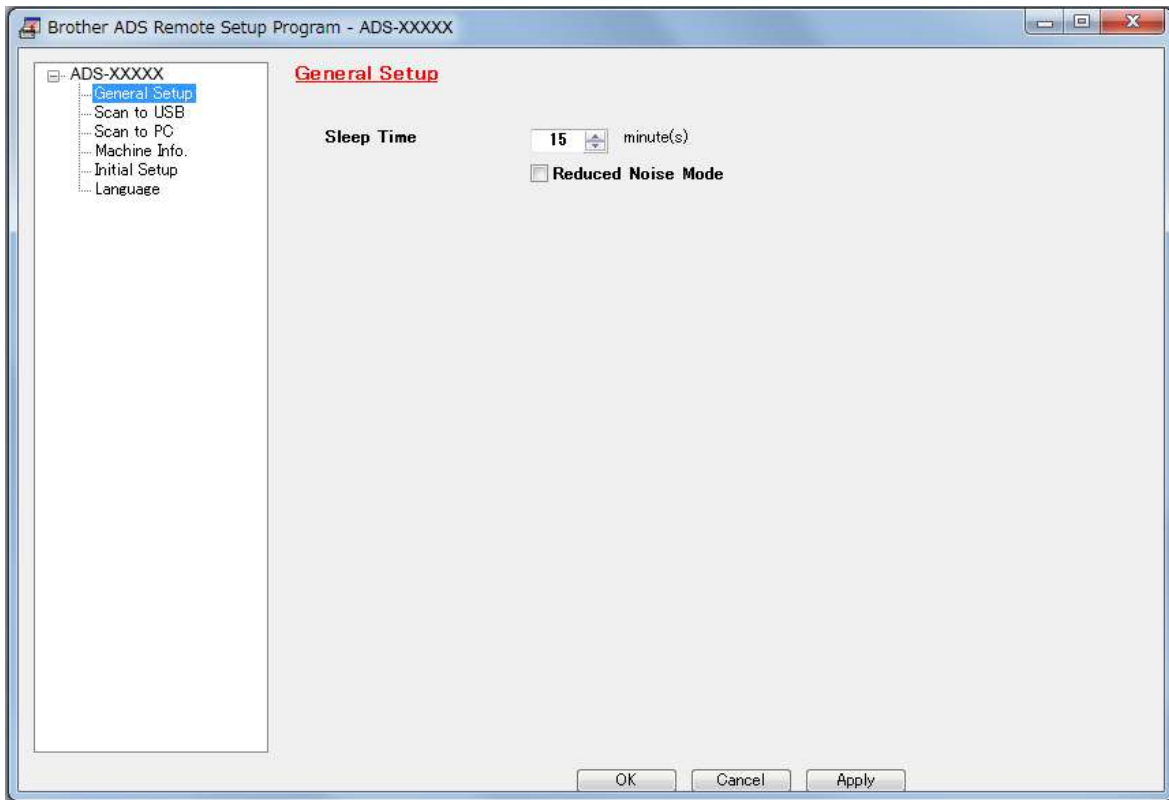



## General Setup (ADS-2500We)

### Set the Backlight Brightness

---



You can adjust the brightness of the LCD backlight. If you are having difficulty reading the LCD, try changing the brightness setting.

- 1 Press .
- 2 Press `General Setup`.
- 3 Press `LCD Settings`.
- 4 Press `Backlight`.
- 5 Press `Light`, `Med` or `Dark`.
- 6 Press .

### Set the Dim Timer for the Backlight

---

You can set how long the LCD backlight stays on after the Ready Screen is shown.

- 1 Press .
- 2 Press `General Setup`.
- 3 Press `LCD Settings`.
- 4 Press `Dim Timer`.
- 5 Press `Off`, `10Secs`, `20Secs` or `30Secs`.
- 6 Press .



### Set the Home Screen

---

You can set the Home Screen as `Clock`, `Scan 1-2` or `Shortcut 1-8`.



For examples of these screens, see *Touchscreen LCD* on page 5.

When the machine is idle or you press , the machine will go back to the Home Screen that you have set.

- 1 Press .
- 2 Press `General Setup`.
- 3 Press `Button Settings`.
- 4 Press `Home Button Settings`.
- 5 Press `Clock`, `Scan 1-2` or `Shortcut 1-8`.
- 6 Press .

## Select Your Language

---

- 1 Press .
- 2 Press ▲ or ▼ to display Initial Setup.  
Press Initial Setup.
- 3 Press Local Language.
- 4 Press ▲ or ▼ to display your language.  
Press your language.
- 5 Press .

## Memory Storage

---



Your menu settings are stored permanently and, in the event of a power failure, will not be lost. Temporary settings will be lost. If you have chosen `Set New Default` for your Scan to USB and Scan to E-mail Server preferred settings, those settings will not be lost. Also, during a power failure, the machine will retain the date and time for approximately 24 hours.

## Beep Volume

---

When the Beep setting is `On`, the machine will beep when you press a key or make a mistake.

You can choose a range of beep volume levels from `Low` to `High`, or choose `Off`.

- 1 Press .
- 2 Press General Setup.
- 3 Press Volume.
- 4 Press Beep.
- 5 Press Low, Med, High or Off.
- 6 Press .

## Automatic Daylight Saving Time

---

You can set the machine to change the time automatically for daylight saving time. The time will be adjusted forward one hour in the spring and adjusted backward one hour in the autumn. Make sure you have set the correct date and time in the `Date & Time` settings.



The factory setting is Off, therefore, you will have to change the Automatic Daylight Saving Time setting to On as follows.

- 1 Press .
- 2 Press `▲` or `▼` to display `Initial Setup`.
- 3 Press `Initial Setup`.
- 4 Press `Date & Time`.
- 5 Press `Auto Daylight`.
- 6 Press `On` (or `Off`).
- 7 Press .

## Sleep Mode

---

You can enter how long the machine must remain idle (the maximum setting is 90 Mins and the default setting is 15 Mins) before it enters Sleep Mode. The timer will restart if any operation is carried out on the machine. If a wireless network is enabled, the machine will not enter Sleep Mode. To disable the wireless network, see *WLAN Enable/Disable (ADS-2500We only)* on page 206.

- 1 Press .
- 2 Press `General Setup`.
- 3 Press `Ecology`.
- 4 Press `Sleep Time`.
- 5 Enter the length of time the machine is idle before entering Sleep Mode.
- 6 Press `OK`.
- 7 Press .

## Power Down Mode

---

Power Down Mode is the lowest power consumption mode. If the machine is in Sleep Mode for four hours, it will go into Power Down Mode automatically. To wake the machine, do one of the following:

- Open the Top Cover.
- Press .
- Load your document.

## Multifeed Detection

---

Multifeed is that multiple pages were fed at the same time. When this feature is set to On, the machine will detect a multifeed error. When this function detects a multifeed, confirm that the data scanned before the multifeed has been saved, and then start scanning again at the next page or the beginning of the document.



### NOTE

---

(Scan to USB only)

If you selected JPEG as the file type, your Brother machine will save all data scanned *before* the multifeed error occurred.

---

- 1 Press .
- 2 Press `General Setup`.
- 3 Press `▲` or `▼` to display `Multifeed Detection`.
- 4 Press `Multifeed Detection`.
- 5 Press `On` (or `Off`).
- 6 Press .

## Reduced Noise Mode

Select the **Reduced Noise Mode** check box in Remote Setup to reduce acoustic noise while scanning. Reducing noise may slow scan speed.

To start Remote Setup, see *Set Up the Brother Machine from Your Computer* on page 167 (the example below uses Windows®).

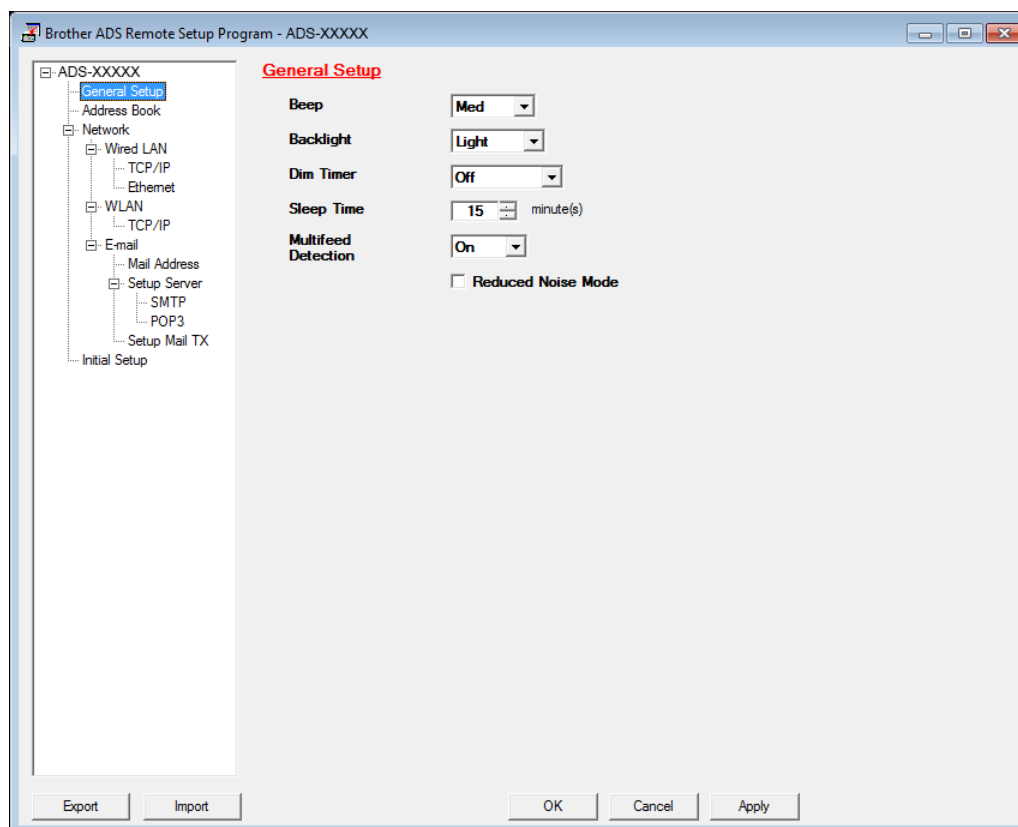

## Setting Lock

Setting Lock lets you set a password to stop other people from accidentally changing your machine settings. Make a careful note of your password. If you forget your password, you will have to reset all of the passwords stored in the machine.

While Setting Lock is On, you cannot change the following settings without a password:

- General Setup
- Shortcut Settings
- Network
- Machine Info.
- Initial Setup
- Save as Shortcut in all Scan-to actions

- Set New Default **and** Factory Reset **in** to USB
- Address Book, Set New Default **and** Factory Reset **in** to E-mail Server



## Set the Password

---

- 1 Press .
- 2 Press General Setup.
- 3 Press ▲ or ▼ to display Security.
- 4 Press Security.
- 5 Press Setting Lock.
- 6 Enter a four-digit number for the password using numbers 0-9.  
Press OK.
- 7 Re-enter your password when the LCD displays Verify:.  
Press OK.
- 8 Press .

## Change the Password

---

- 1 Press .
- 2 Press General Setup.
- 3 Press ▲ or ▼ to display Security.
- 4 Press Security.
- 5 Press Setting Lock.
- 6 Press Set Password.
- 7 Enter your existing four-digit password.  
Press OK.
- 8 Enter a new four-digit number as the password.  
Press OK.
- 9 Re-enter your new password when the LCD displays Verify:.  
Press OK.
- 10 Press .



## Turn Setting Lock On/Off

If you enter the wrong password when performing the following procedure, the LCD will display `Wrong Password`. Re-enter the correct password.

### Turn Setting Lock On

- 1 Press .
- 2 Press `General Setup`.
- 3 Press `▲` or `▼` to display `Security`.
- 4 Press `Security`.
- 5 Press `Setting Lock`.
- 6 Press `Lock Off→On`.
- 7 The LCD prompts you to enter your four-digit password. Enter the password. Press `OK`.

### Turn Setting Lock Off

- 1 Press .
- 2 The LCD prompts you to enter your four-digit password. Enter the password. Press `OK`.
- 3 Press .

## User Restriction Functions

You can set the following two functions:

### ■ Secure Function Lock

Secure Function Lock restricts scan functions and Web Connect functions based on user permissions.

### ■ Active Directory Authentication

Active Directory Authentication restricts the use of your Brother machine. If Active Directory Authentication is enabled, the machine's control panel will be locked. You cannot change the machine's settings until you enter a User ID, domain name and password.

## NOTE

You cannot use both **Secure Function Lock** and **Active Directory Authentication** at the same time.

The following settings can be available when **Secure Function Lock** or **Active Directory Authentication** is on.

Restrict	Function available				
	Active Directory Authentication		Secure Function Lock <sup>1</sup>		
	Login	Logout	Scan: Clear <sup>2</sup>	Scan to USB: Clear	Web Connect Upload: Clear
Setting on the LCD	-	-	-	-	-
Remote Setup	-	-	-	-	-
Web Based Management	Yes	Yes	Yes	Yes	Yes
Scan to PC (From the PC)	Yes	Yes	-	Yes	Yes
Scan to PC (from the LCD)	Yes	-	-	Yes	Yes
Scan to FTP	Yes	-	-	Yes	Yes
Scan to Network	Yes	-	-	Yes	Yes
Scan to EmailServer	Yes	-	-	Yes	Yes
Scan to USB	Yes	-	Yes	-	Yes
Scan to Web	Yes	-	Yes	Yes	-
iPrint&Scan	Yes	Yes	-	Yes	Yes

<sup>1</sup> The available functions can be managed depending on the Login ID you set.

<sup>2</sup> The function restricts the scan functions other than **Scan to USB** and **Scan to Web**.

## 1 Start Web Based Management.

- 1 Start your web browser.

- 2 Type “http://machine’s IP address/” into your browser (where “machine’s IP address” is the machine’s IP address).
  - For example:  
http://192.168.1.2/

**NOTE**

- If you are using a Domain Name System or enable a NetBIOS name, you can enter another name such as “SharedScanner” instead of the IP address.
  - For example:  
http://SharedScanner/
- If you enable a NetBIOS name, you can also use the node name.
  - For example:  
http://brwxxxxxxxxxxxxx/
- You can find the NetBIOS name on the LCD, under *Node Name*.
- For Macintosh users, access the Web Based Management System by clicking the machine icon on the **Status Monitor** screen. For more information, see the *Monitor the Machine’s Status from Your Computer (Macintosh)* on page 164.

- 2 When the Web Based management screen appears, click the **Administrator** tab. In the left navigation bar, click **User Restriction Function**.
- 3 Do one of the following:
  - Click **Secure Function Lock**, and then click **Submit**. Go to 4.
  - Click **Active Directory Authentication**, and then click **Submit**. Go to 5.
- 4 In the left navigation bar, click **Secure Function Lock** to configure the settings. For more information, see *Configure Secure Function Lock* in the *Network User’s Guide*.

Once you set Secure Function Lock, a Public Mode icon appears on your machine’s LCD. Press the Public Mode icon to change the user, based on the settings you changed in Web Based Management.

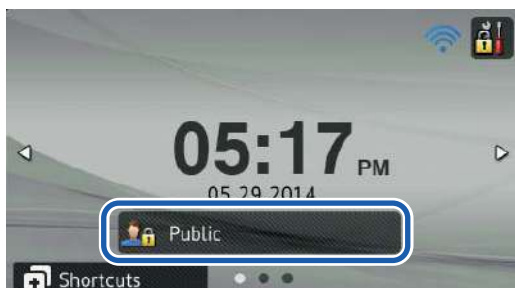

**NOTE**

If you don’t touch the LCD within one minute, the LCD reverts to Public Mode automatically.

- 5 In the left navigation bar, click **Active Directory Authentication** to configure the settings. For more information, see *Configure Active Directory Authentication* in the Network User's Guide.

Once you set Active Directory Authentication, the following screen appears on your machine's LCD.

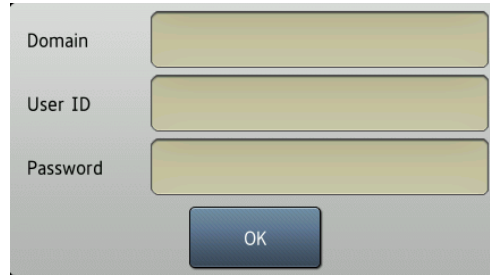

The screenshot shows a configuration dialog box with three text input fields. The first field is labeled 'Domain', the second 'User ID', and the third 'Password'. Below the fields is a blue button labeled 'OK'.

Enter your Brother machine's Domain, User ID and Password.

Once you connect Active Directory Server, the following screen appears on your machine's LCD.

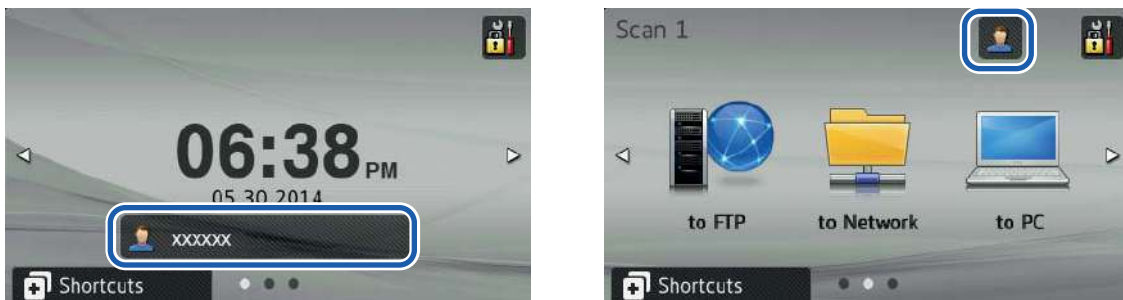

## NOTE

If you don't touch the LCD within one minute, the LCD reverts to logoff screen automatically.

## 2

# Document Specifications

## Acceptable Documents

### NOTE

Do not load documents that contain multiple page thicknesses, paper qualities, etc.

Standard Paper	Length	2.76 to 14 in. (70 to 355.6 mm)	
	Width	2.0 to 8.5 in. (51 to 215.9 mm)	
	Weight	14 to 29 lb (52 to 110 g/m <sup>2</sup> )	
	Thickness	3 to 5 mil (0.08 to 0.12 mm) To scan thinner documents, use the Carrier Sheet.	
	Maximum Number of Pages	Total thickness of no more than 0.2 in. (5 mm), no more than 50 sheets	
	Standard Paper Size	A4	8.3 × 11.7 in. (210 × 297 mm)
	A5	5.8 × 8.3 in. (148 × 210 mm)	
	A6	4.1 × 5.8 in. (105 × 148 mm)	
	A7	2.9 × 4.1 in. (74 × 105 mm)	
	A8	2.0 × 2.9 in. (52 × 74 mm)	
	B5	7.2 × 10.1 in. (182 × 257 mm)	
	B6	5.0 × 7.2 in. (128 × 182 mm)	
	B7	3.6 × 5.0 in. (91 × 128 mm)	
	B8	2.5 × 3.6 in. (64 × 91 mm)	
	Legal	8 1/2 × 14 in. (215.9 × 355.6 mm)	
	Letter	8.5 × 11 in. (215.9 × 279.4 mm)	

Thick Paper	Length	2.76 to 5.8 in. (70 to 147 mm)	
	Width	2.0 to 5.8 in. (51 to 147 mm)	
	Weight	29 to 53 lb (110 to 200 g/m <sup>2</sup> )	
	Thickness	5 to 10 mil (0.12 to 0.25 mm)	
	Maximum Number of Pages	Total thickness of no more than 0.2 in. (5 mm) and no more than 25 sheets	

Long Paper	Length	14 to 34.0 in. (355.6 to 863 mm)
	Width	2.0 to 8.5 in. (51 to 215.9 mm)
	Weight	14 to 29 lb (52 to 110 g/m <sup>2</sup> )
	Thickness	3 to 5 mil (0.08 to 0.12 mm) To scan thinner documents, use the Carrier Sheet.
	Maximum Number of Pages	1 page

**NOTE**

To scan a document between 14 to 34.0 in. (355.6 to 863 mm), select **Long Paper** as **Scan Size** or **Document Size** in the settings dialog box.

Plastic Card (Non-embossed Card Only)	Size (ISO)	3.37 × 2.13 × 0.03 in. (85.6 × 54.0 × 0.76 mm)
	Material	Plastic (PET)
	Type	Plastic card such as driver's license or store card
	Thickness	10 to 30 mil (0.25 to 0.76 mm)
	Maximum Number of Pages	1 page

**NOTE**

A plastic card can be scanned and saved to your computer as an image file. Select the **Plastic Card Mode** check box in the settings dialog box.

Carrier Sheet	Thickness	Total thickness of no more than 0.6 mm (one 0.3 mm document plus the Carrier Sheet)
	Maximum Number of Pages	1 page

**NOTE**

A Carrier Sheet can be used when saving the scanned image to your computer. The Carrier Sheet cannot be used when scanning to a USB flash drive. Select the **Carrier Sheet Mode** check box in the setting dialog box.

## Unacceptable Documents

- Documents with a carbon sheet attached
- Documents written in pencil
- Documents of uneven thickness, such as envelopes
- Documents with large wrinkles or curls
- Bent or damaged documents
- Documents that use tracing paper
- Documents that use coated paper
- Photographs (photographic paper)
- Documents printed on perforated paper
- Documents printed on unusually-shaped paper (not square or rectangle)
- Documents with photos, notes, or stickers affixed to them
- Documents that use carbonless paper
- Documents that use loose-leaf paper or any paper with holes in it
- Documents with paper clips or staples
- Documents with wet ink
- Fabrics, metallic sheets, or overhead projector sheets
- Glossy or mirrored media
- Documents that exceed recommended thicknesses

### **IMPORTANT**

---

If you use any of the Unacceptable Documents and damage your Brother machine, it may not be covered under warranty.

---

## Carrier Sheet Recommendations

- Documents with a carbon sheet attached
- Documents written in pencil
- Documents narrower than 2.0 in. (51 mm) wide
- Documents shorter than 2.76 in. (70 mm) long
- Pages thinner than 3 mil (0.08 mm)
- Documents of uneven thickness, such as envelopes
- Documents with large wrinkles or curls
- Bent or damaged documents
- Documents that use tracing paper
- Documents that use coated paper
- Photographs (photographic paper)
- Documents printed on perforated paper
- Documents printed on unusually-shaped paper (not square or rectangle)
- Documents with photos, notes, or stickers affixed to them
- Documents that use carbonless paper
- Documents that use loose-leaf paper or any paper with holes in it

### CAUTION

To avoid cutting yourself, do not slide or scrape your hand or fingers along the edge of the Carrier Sheet.

### IMPORTANT

- To avoid warping, do not place the Carrier Sheet in direct sunlight or in an area subject to high temperatures and high humidity. Do not store the Carrier Sheet horizontally with a large object placed on top of it.
- To avoid damaging the Carrier Sheet, do not bend or pull it. If the Carrier Sheet becomes damaged, it may not be able to be used correctly for scanning, and should not be used.

## Notes for Using Carrier Sheets

- To avoid document jams, do not load the Carrier Sheet upside down. Refer to the instructions printed on the Carrier Sheet itself for more information or see *Load Documents* on page 30.
- To avoid document jams, do not put several small documents into the Carrier Sheet at the same time. Insert only one document into the Carrier Sheet at a time.
- Do not write on the Carrier Sheet, as the writing may be seen in scanned documents. If the Carrier Sheet becomes dirty, wipe it with a dry cloth.
- Do not leave documents in the Carrier Sheet for extended periods of time, as the printing on the documents may bleed through onto the Carrier Sheet.

### IMPORTANT

---

If you use any of the Unacceptable Documents and damage your Brother machine, it may not be covered under warranty.

---

# 3

## Scan Preparation

### Set Up Your Scanner

- 1 Open the Top Cover ①.

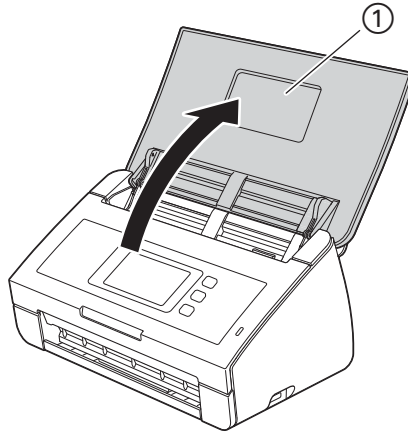

- 2 Pull the Output Tray ① out of the machine and then unfold the Document Stopper ②.

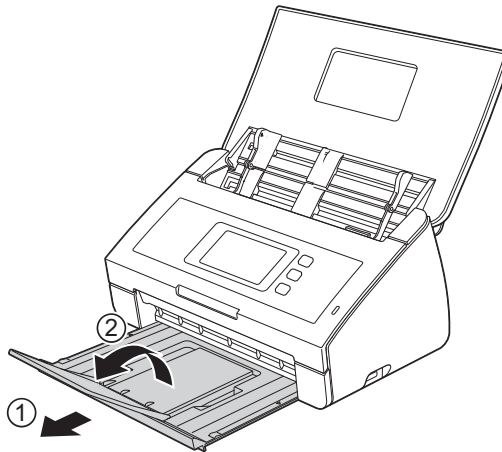

## Load Documents

The Automatic Document Feeder (ADF) can hold up to 50 pages and feeds each sheet individually. Use 20 lb (80 g/m<sup>2</sup>) paper and always fan the pages before placing them in the ADF.

### IMPORTANT

- Make sure documents with ink or correction fluid are completely dry.
- DO NOT pull on the document while it is feeding.
- DO NOT use paper that is curled, wrinkled, folded, ripped, stapled, paper clipped, pasted or taped.
- DO NOT use cardboard or fabric.

### Standard-size Documents

- 1 Adjust the Document Guides ① to fit the width of your document.

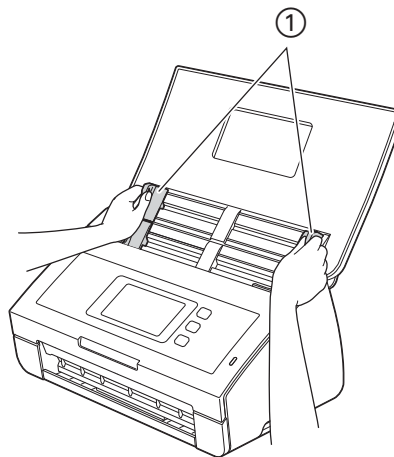

- 2 Fan the pages several times along both the long edge and the short edge.

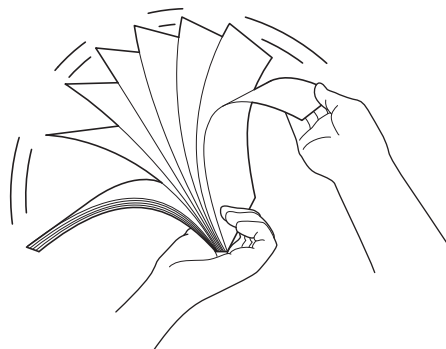

- 3 Align the edges of the pages.

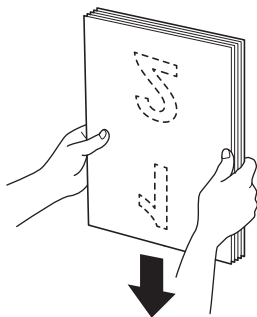

- 4 Position the pages so that the leading edges are aligned at a slight angle in the feed direction.

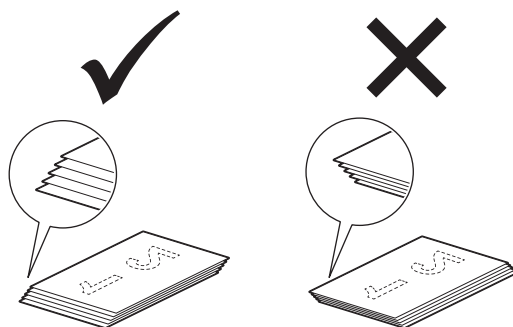

- 5 Place your document, **face down**, **top edge first** in the ADF between the Guides until you feel it touch the inside of the machine gently.

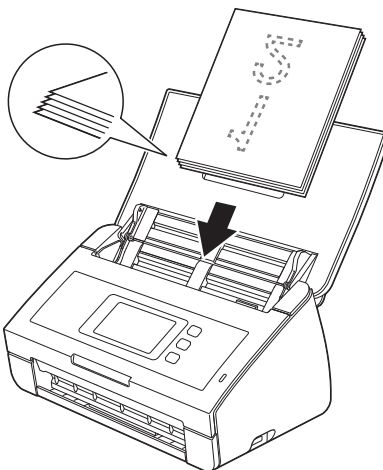

## Business Cards and Plastic Cards

---

- 1 Adjust the Document Guides ① to fit the width of your document.

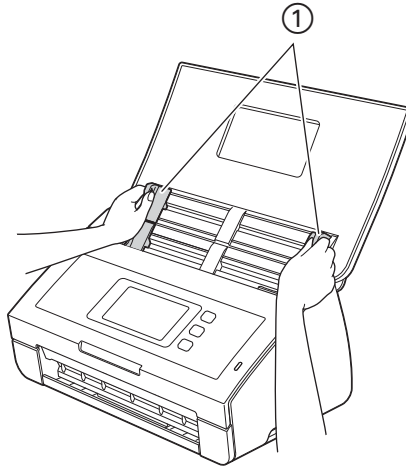

- 2 Place your card, **face down, top edge first, and lengthwise** in the ADF between the Guides until you feel it touch the inside of the machine.

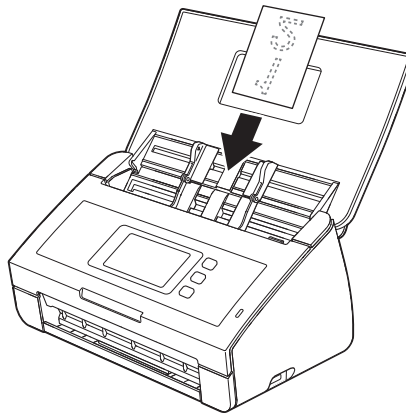

### NOTE

---

- Load only one plastic card at a time.
  - Certain types of plastic cards may be scratched when scanned. To prevent damage to the card, we recommend using the Plastic Card Carrier sheet.
-

## Documents Longer than Standard-size

---

Make sure documents with ink or correction fluid are completely dry.

- 1 Adjust the Document Guides ① to fit the width of your document.

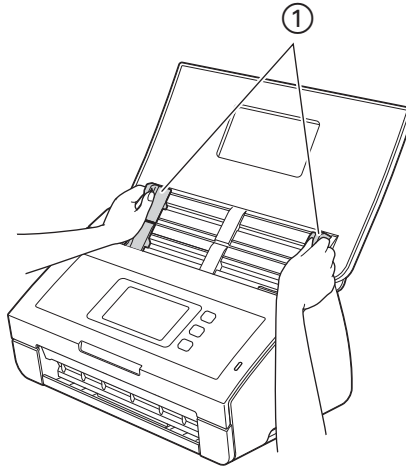

- 2 Place your document, **face down, top edge first** in the ADF between the Guides until you feel it touch the inside of the machine.

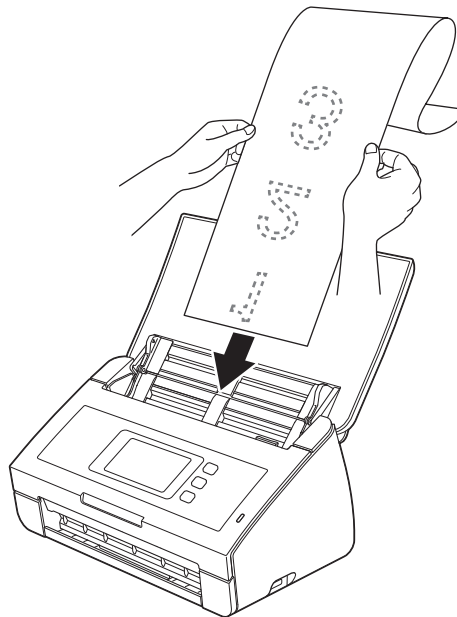

### NOTE

---

- Load only one document at a time.
  - Support the document with your hand if the document is longer than the Top Cover.
-

## Documents not printed on standard-size paper

---

Make sure documents with ink or correction fluid are completely dry.

- 1 Fold your document in half and insert it into the Carrier Sheet.

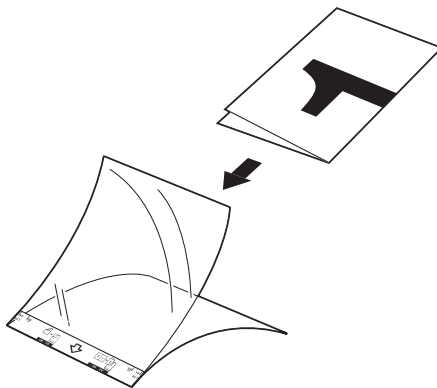

### NOTE

---

Set the document in the center of the Carrier Sheet and align the top of the document with the top of the Carrier Sheet.

---

- 2 Adjust the Document Guides ① to fit the width of the Carrier Sheet.

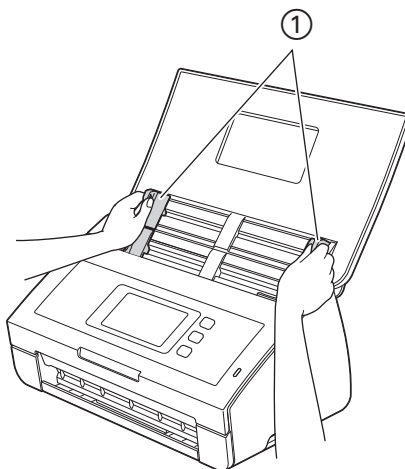

- 3 Place the Carrier Sheet in the ADF between the Guides until you feel it touch the inside of the machine.

## NOTE

To reduce the white space in the center of a scanned page, be sure to position the folded edge of the original document close to the edge of the Carrier Sheet.

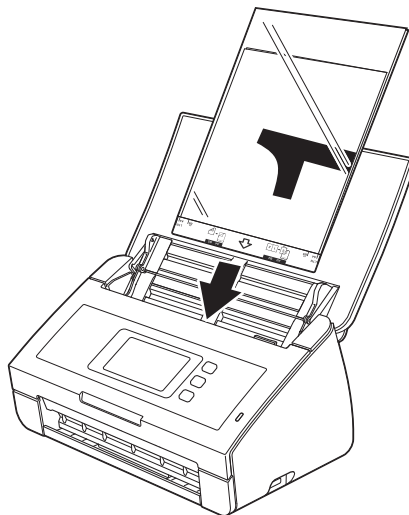

## Documents with Facing Pages

Follow the steps of *Documents not printed on standard-size paper* on page 34.

## Receipts, Clippings, Photos, and Other Documents

Make sure documents with ink or correction fluid are completely dry.

- 1 Insert the document into the Carrier Sheet.

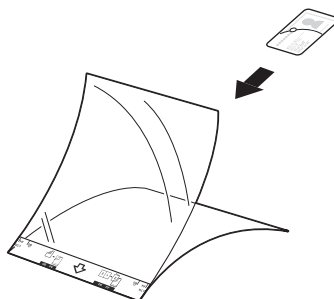

## NOTE

- Set the document in the center of the Carrier Sheet and align the top of the document with the top of the Carrier Sheet.
- You can fold the receipt in two places so that it overlaps and then insert it into the Receipt Carrier Sheet if the receipt is longer than the Receipt Carrier Sheet.

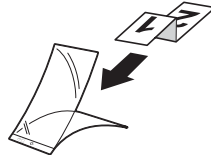

- 2 Adjust the Document Guides ① to fit the width of the Carrier Sheet.

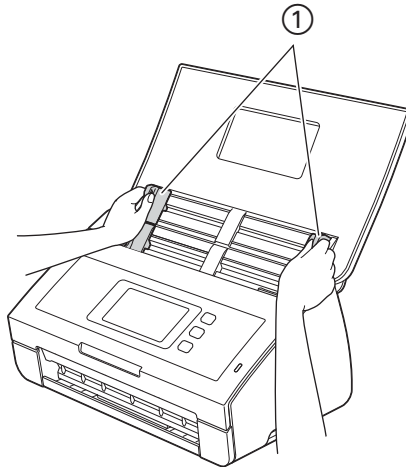

- 3 Place the Carrier Sheet in the ADF between the Guides until you feel it touch the inside of the machine.

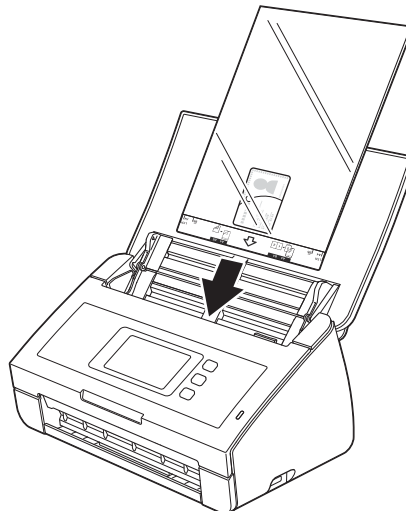

# 4

## Prepare Your Network

### Before Scanning

Before scanning, confirm the following:

- Make sure you have installed the Brother software (MFL-Pro Suite) by following the steps in the Quick Setup Guide.
- If your Brother machine is connected via cable, make sure that the interface cable is physically secure.

## Before Network Scanning (ADS-2500We only)

### Network License (Windows®)

---

This product includes a computer license for up to two users.

This license supports the installation of the MFL-Pro Suite software including Nuance™ PaperPort™ 12SE on up to two computers on the network.

### Configure Network Scanning for Windows®

---

If you are using a different machine than the one that was originally registered to your computer during the installation of MFL-Pro Suite software, follow the steps below.

- 1 Click  (**Brother Utilities**) on your desktop, and then click the drop-down list and select your model name (if not already selected). Click **SCAN** in the left navigation bar, and then click **Scanners and Cameras**.
- 2 Do one of the following:
  - Windows® XP  
Right-click the Scanner Device icon and choose **Properties**.  
The Network Scanner Properties dialog box appears.
  - Windows Vista®, Windows® 7, Windows® 8 and Windows® 8.1  
Click the **Properties** button.

## NOTE

(Windows Vista®, Windows® 7, Windows® 8 and Windows® 8.1)

If the **User Account Control** screen appears, do the following:

- For users who have administrator rights: Click **Continue** or **Yes**.

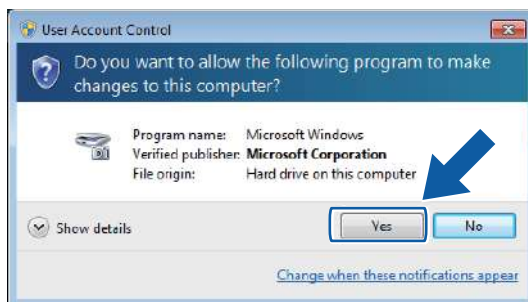

- For users who do not have administrator rights: Type the administrator password and click **OK** or **Yes**.

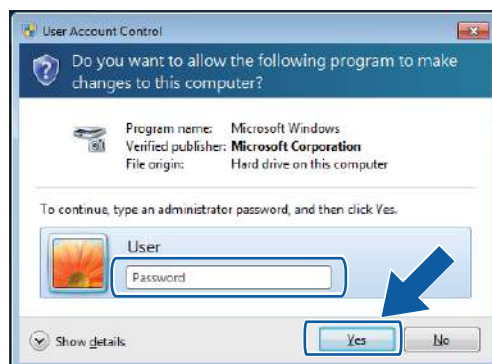

- 3 Click the **Network Setting** tab and choose the appropriate connection method.

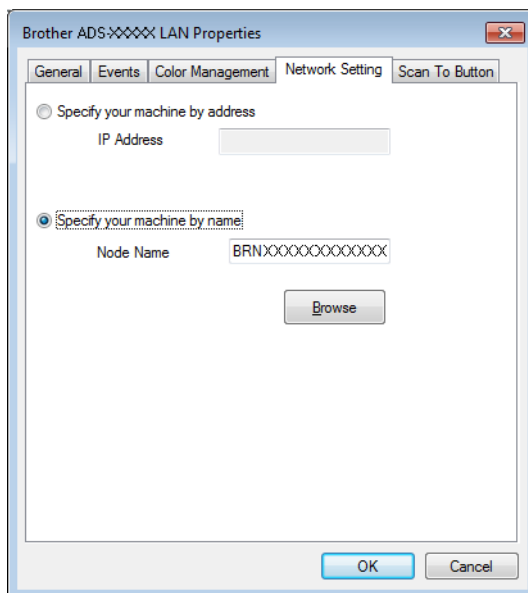

### Specify your machine by address

Type the IP address of the machine in **IP Address**, and then click **Apply** or **OK**.

### Specify your machine by name

- 1 Type the machine node name in **Node Name**, or click **Browse** and choose the machine you want to use.
- 2 Click **OK**.

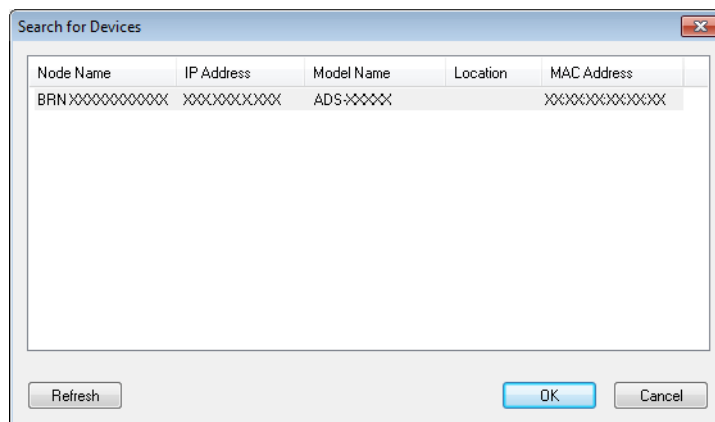

- 4 Click the **Scan To Button** tab and type your computer name in the **Display Name** field. The machine's LCD displays the name you enter. The default setting is your computer name. You can enter any name that you like.

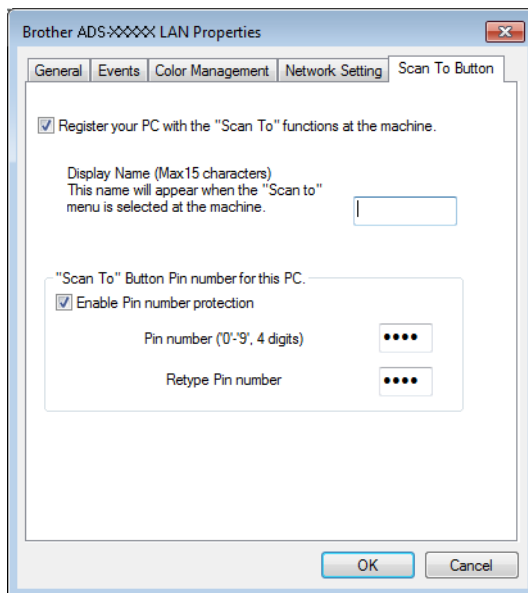

- 5 To avoid receiving unwanted documents, type a four-digit PIN in the **Pin number** and **Retype Pin number** fields.  
If you send scan data to a computer protected by a PIN, the machine's LCD prompts you to enter the PIN before the document can be scanned and sent to the computer.

## Configure Network Scanning for Macintosh

If you followed the network installation steps in the Quick Setup Guide, your Brother machine was added to your network automatically. Otherwise, add it to your network using ControlCenter2.

To use the machine as a network scanner, the machine must be configured with a TCP/IP address. You can set or change the address settings from the Control Panel.

- 1 Click the  (ControlCenter2) icon in the Dock. The **ControlCenter2** window appears.



- 2 Select **Other** from the **Model** pop-up menu.  
The **Device Selector** window appears.

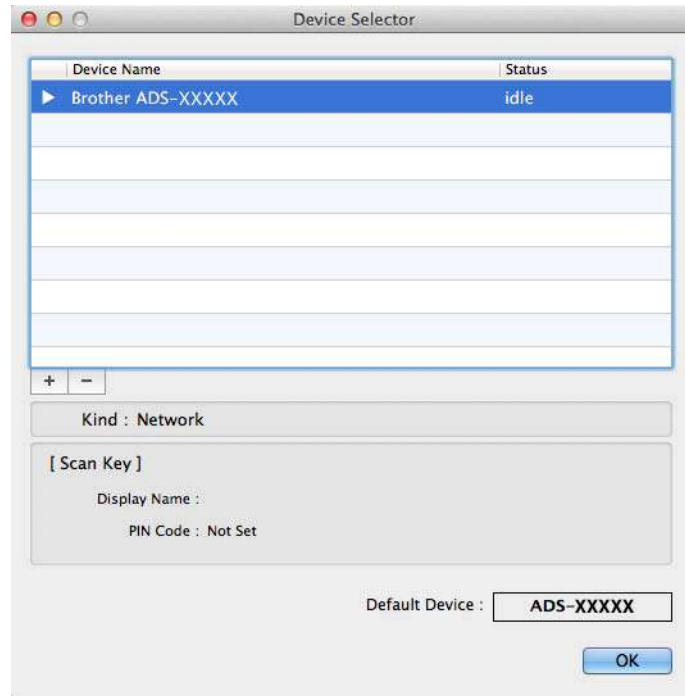

- 3 Click the **+** button. The setting window appears.
- 4 Select your machine from the list and then click **Add**.

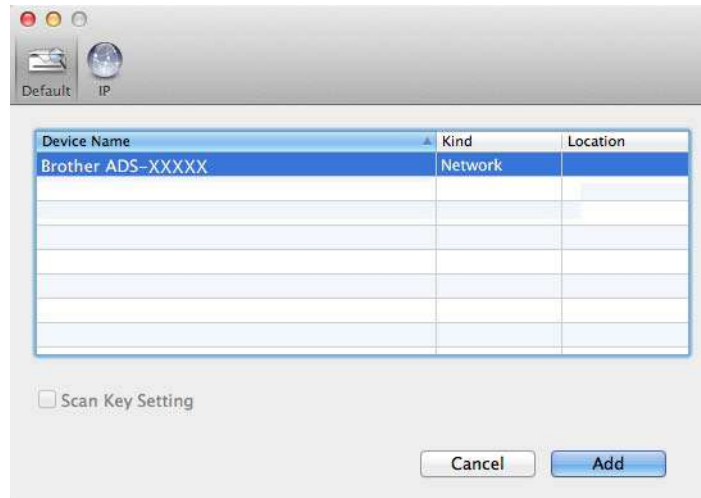

## NOTE

You can also select your machine by entering the IP address. Click **IP** and then specify your machine by IP address.

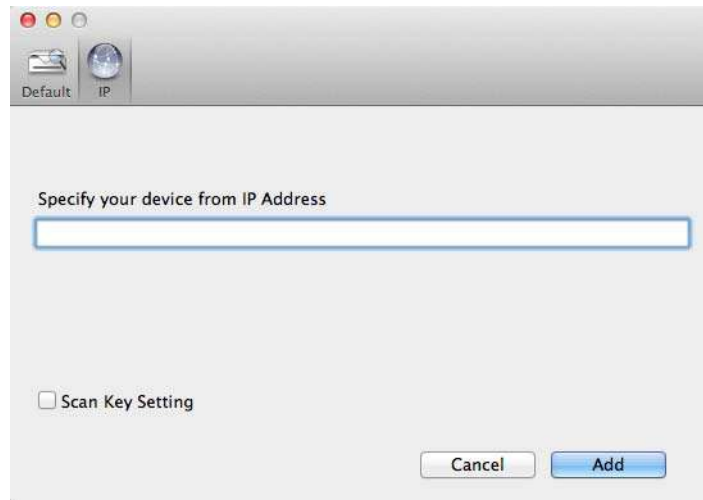

5 Click **Add**.

## NOTE

While specifying your machine's IP address, you can also configure **Scan Key Setting**. Select the **Scan Key Setting** check box to set the following options:

- To scan from the machine's Control Panel to your computer, type your computer's name in the **Display Name** field. The name you type will appear as a destination option on your machine's LCD.
- To avoid receiving unwanted scanned documents, select the **Enable PIN code protection** check box, type your PIN in the **PIN code** field, and retype it in the **Verify** field.

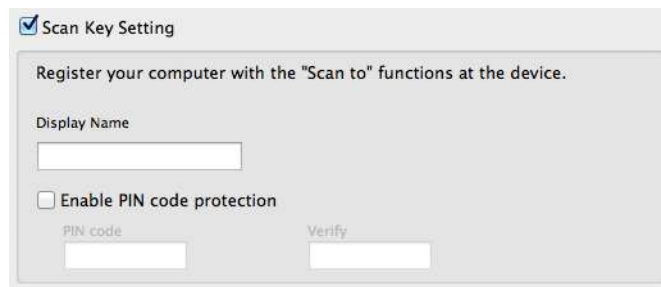

## Launch the BRAdmin Utility (Windows®)

---

If you have installed BRAdmin Light or BRAdmin Professional 3, the **BRAdmin** button lets you open the BRAdmin Light or BRAdmin Professional 3 utility.

The BRAdmin Light utility is designed for initial setup of Brother network-connected devices. It can also search for Brother products in a TCP/IP environment, view the status and configure basic network settings, such as the IP address. For information about installing BRAdmin Light from the supplied DVD-ROM, see the Network User's Guide.

If you require more advanced machine management, use the latest version of BRAdmin Professional 3 utility that is available as a download from <http://support.brother.com>

4

- 1 Click the  (ControlCenter4) icon in the task tray and then select **Open** from the menu. The **ControlCenter4** window appears.
- 2 Click the **Device Settings** tab.
- 3 Click **BRAdmin**. The BRAdmin Light or BRAdmin Professional 3 utility dialog box appears.

### NOTE

---

If you have installed both BRAdmin Light and BRAdmin Professional, ControlCenter4 will launch BRAdmin Professional 3.

---

## Change the ControlCenter4 User Interface (Windows®)

ControlCenter4 is a software utility that lets you quickly and easily access your frequently-used applications. Using ControlCenter4 eliminates the need to manually launch specific applications.

ControlCenter4 also controls the settings for the **to PC** button on your Brother machine. For information about how to configure the settings for the **to PC** button on the machine, see *Change Scan to PC Settings (Windows®)* on page 147.

ControlCenter4 has two operation modes: **Home Mode** and **Advanced Mode**. You can change the mode at any time.

### ■ Home Mode

Lets you access your machine's main functions.

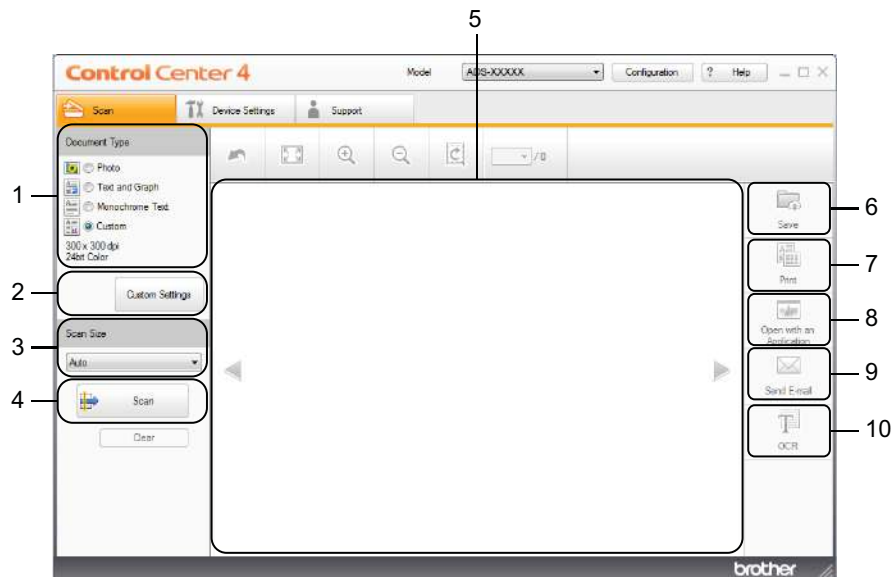

#### 1 Document Type option

Click to select a document type.

#### 2 Custom Settings button

Click to configure scan settings.

#### 3 Scan Size drop-down list

Click to select a scan size.

#### 4 Scan button

Click to start scanning.

#### 5 Image viewer

Click to display a scanned image.

**6 Save button**

Click to save a scanned image to a folder on your hard disk in one of the file types shown in the file type list.

**7 Print button**

Click to print the scanned document on your printer.

**8 Open with an Application button**

Click to scan an image directly into your graphics application for image editing.

**9 Send E-mail button**

Click to scan a document to your default email application.

**10 OCR button**

Click to scan a document and convert it to text.

■ **Advanced Mode**

Gives you more control over the details of your machine's functions. You can customize one-button scan actions to meet your scanning needs.

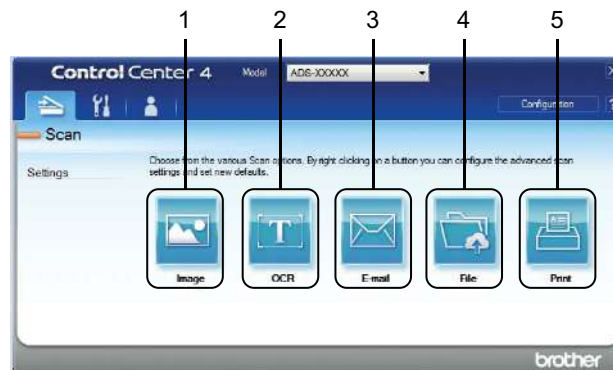

**1 Image button**

Click to scan a document directly into any graphic viewer/editor application.

**2 OCR button**

Click to scan a document and convert it to text.

**3 E-mail button**

Click to scan a document to your default email application.

**4 File button**

Click to save a scanned image to a folder on your hard disk in one of the file types shown in the file type list.

**5 Print button**

Click to print the scanned document on your printer.

To change ControlCenter4's operation mode:

- 1 Click the  (ControlCenter4) icon in the task tray and then select **Open** from the menu. The **ControlCenter4** window appears.

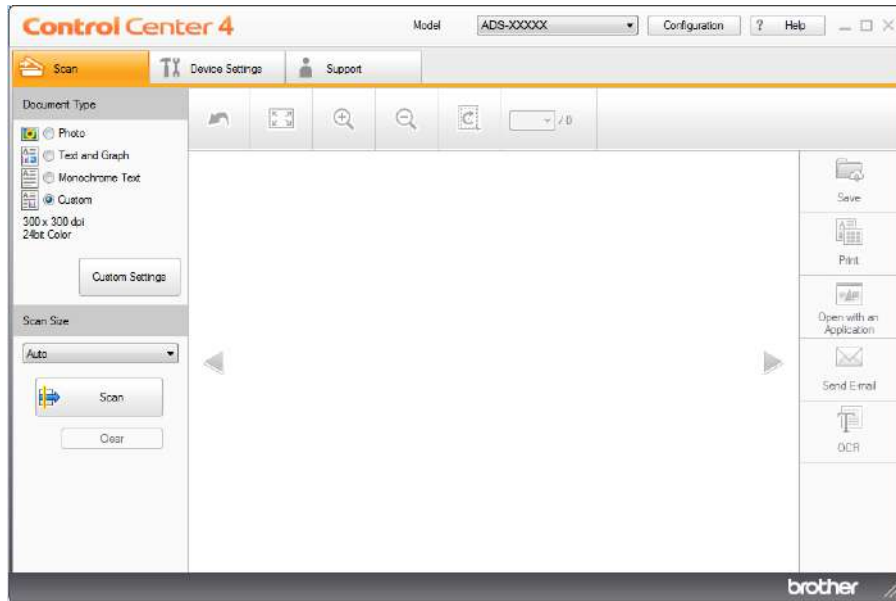

## NOTE

If the  icon is not displayed in the task tray,

click  (**Brother Utilities**) on your desktop, and then click the drop-down list and select your model name (if not already selected). Click **SCAN** in the left navigation bar, and then click **ControlCenter4**.

- 2 Click **Configuration** and then select **Mode Select**.

- 3 Select **Home Mode** or **Advanced Mode**, and then click **OK**.

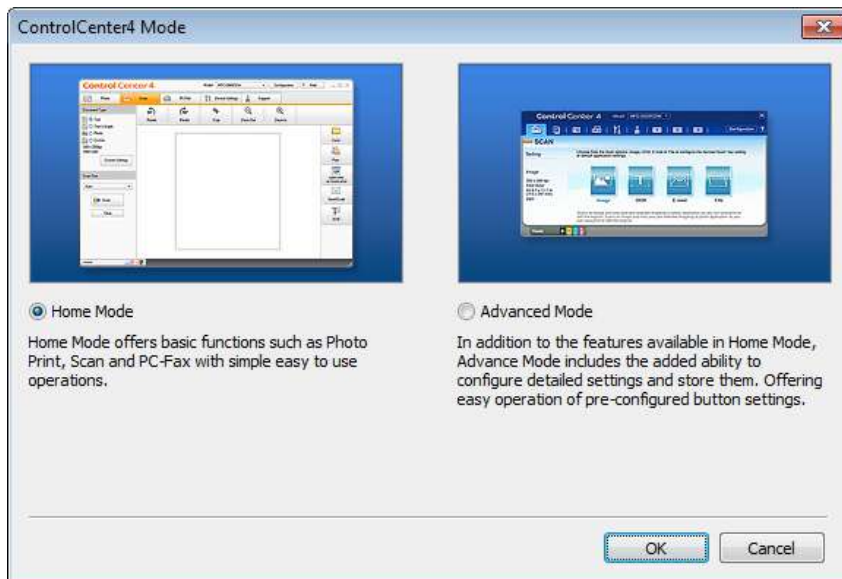





## Scan Using ControlCenter4 in Home Mode (Windows®)

There are five scan options: **Save**, **Print**, **Open with an Application**, **Send E-mail** and **OCR**.

This section briefly introduces the **Scan** tab function. For more details of each function, click  (**Help**).

### Basic Scan



---

- 1 Select the **Document Type** and **Scan Size** for your document.
- 2 Click  (**Scan**).
- 3 Confirm and edit (if needed) the scanned image in the image viewer.
- 4 Click one of the following:
  - For  (**Save**)  
Select your **Destination Folder** and other settings. Click **OK**.  
The image will be saved in your chosen folder.
  - For  (**Print**)  
Select your printer from the drop-down list, configure the printer settings, and then click **OK**.  
The scanned document will print.
  - For  (**Open with an Application**)  
Select the application from the drop-down list, and then click **OK**.  
The image appears in the application you have chosen.

### NOTE

---

If you have installed the Evernote application in your computer, you can select Evernote from the drop-down and then click **OK** to upload the scanned data to Evernote directly.

- For  (**Send E-mail**)  
Configure the attached file settings, and then click **OK**.  
Your default email application will open and the image will be attached to a new email.
- For  (**OCR**)  
Configure the OCR settings, and then click **OK**.  
The application you have chosen will open with the converted text data.

### NOTE

---

To use OCR, Nuance™ PaperPort™ 12SE must be installed on your computer.

---

## Scan Documents Using the Carrier Sheet

- 1 Load your document into the Carrier Sheet and load the Carrier Sheet into your machine (see *Receipts, Clippings, Photos, and Other Documents* on page 35).

### NOTE

Load only one Carrier Sheet at a time.

- 2 Click the  (ControlCenter4) icon in the task tray and then select **Open** from the menu. The **ControlCenter4** window appears.

### NOTE

If the  icon is not displayed in the task tray,

click  (**Brother Utilities**) on your desktop, and then click the drop-down list and select your model name (if not already selected). Click **SCAN** in the left navigation bar, and then click **ControlCenter4**.

- 3 Click the **Scan** tab.

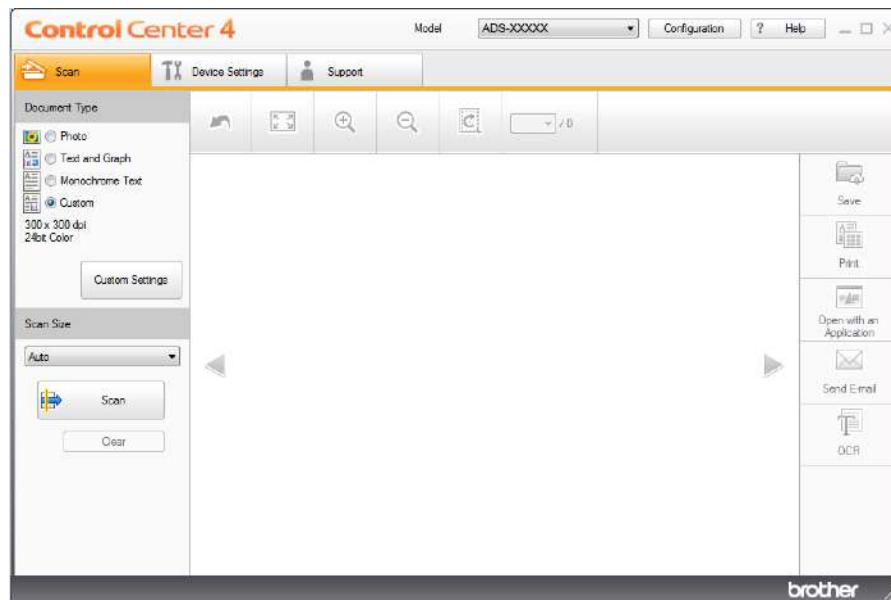



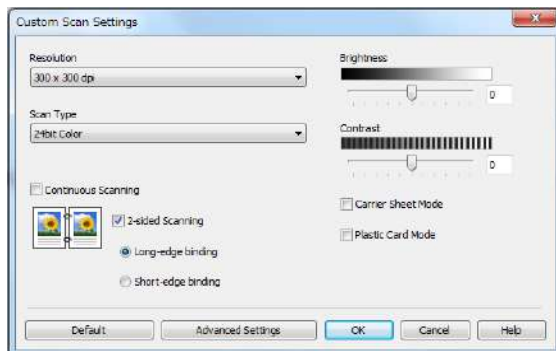

- 4 Select **Custom** in the **Document Type** drop-down list and then click the **Custom Settings** button. The **Custom Scan Settings** dialog box appears.



- 5 Select the **Carrier Sheet Mode** check box.
- 6 Configure other settings if needed (see *Change Scan Settings (ControlCenter4) (Windows®)* on page 67).
- 7 Select a scan size other than **Auto** from the **Scan Size** drop-down list.
- 8 Click the  (**Scan**) button. The machine starts scanning, and then the **Scanning Completed** dialog box appears and display the number of scanned pages. The scanned image appears in the image viewer.

## NOTE

If the **Scanning Completed** dialog box does not appear and you want to display the number of scanned pages, select the **Display Scanning Results** check box.

- 9 Do one of the following:
- Click the  (**Save**) button to save the scanned data. See *Basic Scan* on page 50.
  - Click the  (**Print**) button to print the scanned data. See *Basic Scan* on page 50.
  - Click the  (**Open with an Application**) button to open the scanned data in another application. See *Basic Scan* on page 50.
  - Click the  (**Send E-mail**) button to attach the scanned data to an email. See *Basic Scan* on page 50.
  - Click the  (**OCR**) button to scan to an editable text file. See *Basic Scan* on page 50.

## Scan Plastic Cards

- 1 Load a plastic card (see *Business Cards and Plastic Cards* on page 32).

### NOTE

Load only one plastic card at a time.

- 2 Click the  (ControlCenter4) icon in the task tray and then select **Open** from the menu. The **ControlCenter4** window appears.
- 3 Click the **Scan** tab.

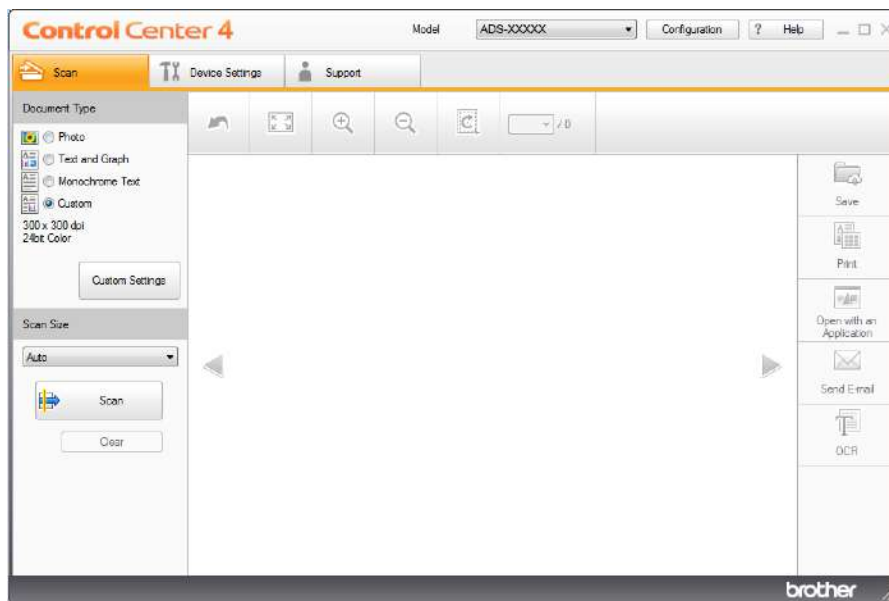

- 4 Select **Custom** in the **Document Type** drop-down list, and then click the **Custom Settings** button. The **Custom Scan Settings** dialog box appears.

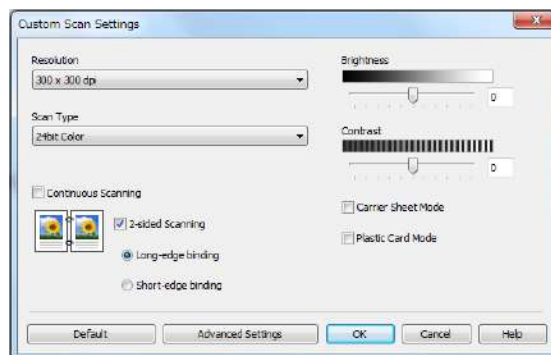





- 5 Select the **Plastic Card Mode** check box.
- 6 Configure other settings if needed (see *Change Scan Settings (ControlCenter4) (Windows®)* on page 67).

- 7 Click the  (**Scan**) button. The machine starts scanning, and then the **Scanning Completed** dialog box appears. The scanned image appears in the image viewer.

**NOTE**

If the **Scanning Completed** dialog box does not appear and you want to display the number of scanned pages, select the **Display Scanning Results** check box.

- 8 Do one of the following:
  - Click the  (**Save**) button to save the scanned data. See *Basic Scan* on page 50.
  - Click the  (**Print**) button to to print the scanned data. See *Basic Scan* on page 50.
  - Click the  (**Open with an Application**) button to open the scanned data in another application. See *Basic Scan* on page 50.
  - Click the  (**Send E-mail**) button to attach the scanned data to an email. See *Basic Scan* on page 50.
  - Click the  (**OCR**) button to scan to an editable text file. See *Basic Scan* on page 50.

**NOTE**

**Plastic Card Mode** automatically uses these settings:

**Resolution:** 600 x 600 dpi

**Scan Size:** 2 in 1 (Auto)

**2-sided Scanning:** On (**Short-edge binding**)

**Auto Deskew:** Off

**Multifeed Detection:** Off

**Auto Image Rotation:** Off

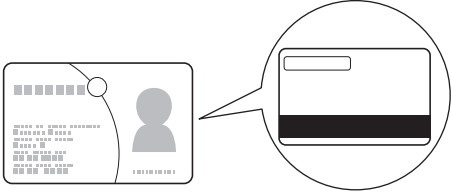
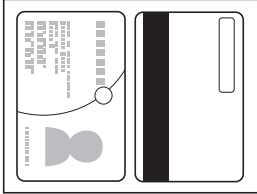
Original Layout	Scan Result
	

## Scan to an Office File

Your machine can convert scanned data to a Microsoft® Word file or a Microsoft® PowerPoint® file. The OCR language is same as the language selected when you installed the ControlCenter4. In order to use this feature, your Brother machine must be connected to a network that has access to the Internet through a wireless or Ethernet connection.

- 1 Load your document (see *Standard-size Documents* on page 30).
- 2 Click the  (ControlCenter4) icon in the task tray and then select **Open** from the menu. The **ControlCenter4** window appears.
- 3 Click the **Scan** tab.

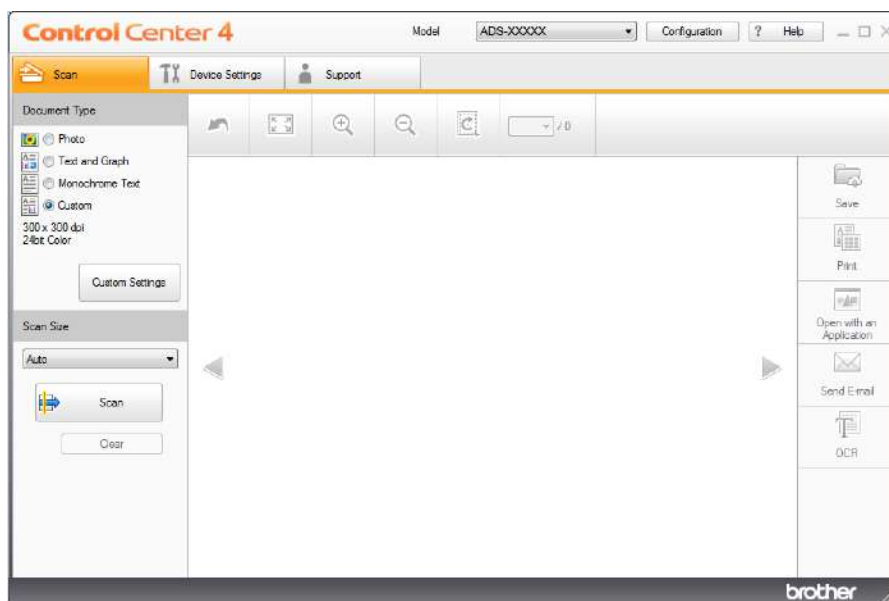

- 4 Select the document type.
- 5 Change the size of your document, if needed.
- 6 Configure other settings if needed (see *Change Scan Settings (ControlCenter4) (Windows®)* on page 67).
- 7 Click the  (**Scan**) button. The machine starts scanning, and then the **Scanning Completed** dialog box appears and display the number of scanned pages. The scanned image appears in the image viewer.

### NOTE

If the **Scanning Completed** dialog box does not appear and you want to display the number of scanned pages, select the **Display Scanning Results** check box.

- 8 Click  (**Save**) or  (**Send E-mail**). The setting dialog box appears.

- 9 Click the **File Type** drop-down list, and then select the **Microsoft Office Word (\*.docx)** or **Microsoft Office PowerPoint (\*.pptx)** option.
- 10 Click **OK**. If a message dialog box regarding the Internet connection appears, read the information and click **OK**.

## Scan Business Cards

---

- 1 Load your document (see *Business Cards and Plastic Cards* on page 32).
- 2 Click the  (ControlCenter4) icon in the task tray and then select **Open** from the menu. The **ControlCenter4** window appears.
- 3 Click the **Scan** tab.

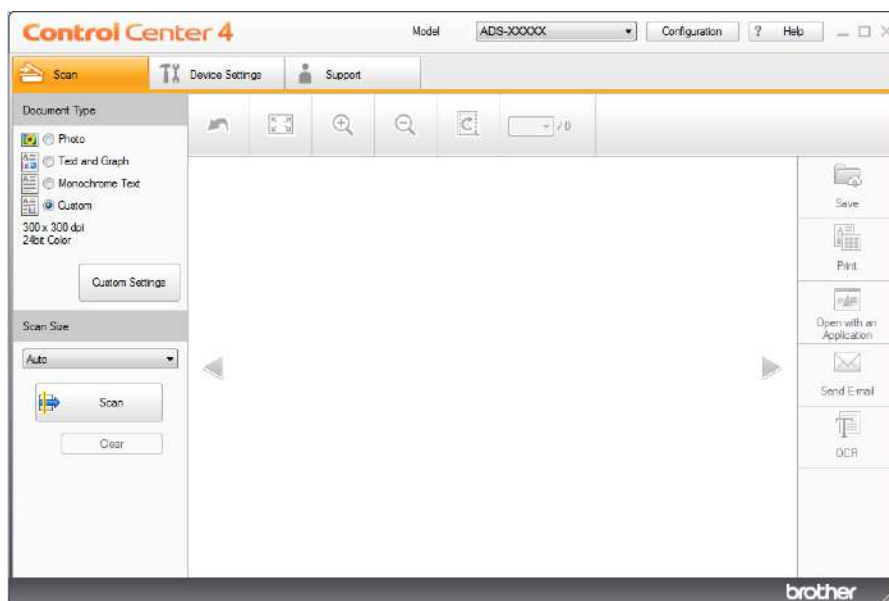

- 4 Select the document type.
- 5 Select **Business Card** from the **Scan Size** drop-down list.
- 6 Configure other settings if needed (see *Change Scan Settings (ControlCenter4) (Windows®)* on page 67).
- 7 Click the  (**Scan**) button. The machine starts scanning, and then the **Scanning Completed** dialog box appears and display the number of scanned pages. The scanned image appears in the image viewer.

### NOTE

---

If the **Scanning Completed** dialog box does not appear and you want to display the number of scanned pages, select the **Display Scanning Results** check box.

---

- 8 Click  (**Open with an Application**). The **Open with an Application** dialog box appears.
- 9 Select **BizCard MFC Application** from the **Target Application** drop-down list, and then click **OK**. The scanned data will be opened in the BizCard 6 application.
- 10 Edit and save the scanned data using BizCard 6.





## Scan Using ControlCenter4 in Advanced Mode (Windows®)

There are five scan options available in Advanced Mode: **Image**, **OCR**, **E-mail**, **File** and **Print**.

This section briefly introduces the **Scan** tab function. For details of each function, click  (**Help**).

### Basic Scan

---

- 1 Click the **Scan** tab.
- 2 Click one of the following:
  - For  (**Image**)  
Select the application from the drop-down list and click **Scan**.  
The image appears in the application you have chosen.
  - For  (**OCR**)  
Configure the OCR settings and click **Scan**.  
The application you have chosen will open with the converted text data.
  - For  (**E-mail**)  
Configure the attached file settings and click **Scan**.  
Your default email application will open and the image will be attached to a new email.
  - For  (**File**)  
Select your **Scan Location** and other settings. Click **Scan**.  
The image will be saved in your chosen folder.
  - For  (**Print**)  
Select your printer from the drop-down list, configure the printer settings, and then click **Scan**.  
The scanned document will print.

### NOTE

---

- (For **Image** and **OCR**)  
If you have installed the Evernote application in your computer, you can select Evernote from the drop-down list and then click **OK** to upload the scanned data to Evernote directly.
  - (For **OCR**)  
Nuance™ PaperPort™ 12SE must be installed on your computer.
-

## Change a Scan Button's Default Settings

- 1 Right-click the button that you want to configure and click **Button settings**. The settings dialog box appears.
- 2 Choose the settings for **File Type**, **Resolution**, **Scan Type**, **Document Size**, **Brightness**, **Contrast**, **Continuous Scanning** and **2-sided Scanning** as needed.
- 3 Click **OK**. The new settings will be used as the default settings.

## Scan Using the Carrier Sheet

- 1 Load your document into the Carrier Sheet and load the Carrier Sheet into your machine (see *Receipts, Clippings, Photos, and Other Documents* on page 35).

### NOTE

Load only one Carrier Sheet at a time.

- 2 Click the  (ControlCenter4) icon in the task tray and then select **Open** from the menu. The **ControlCenter4** window appears.
- 3 Select the **Scan** tab.



- Click the button you want to use (  (**Image**),  (**OCR**),  (**E-mail**),  (**File**) or  (**Print**)). The setting dialog box will appear (the example below uses **Image**).

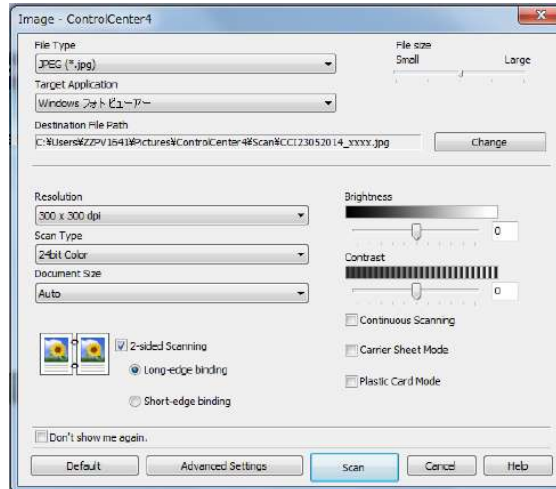

- Check the **Carrier Sheet Mode** check box.
- Select a document size other than **Auto** from the **Document Size** drop-down list.
- Change other settings if needed (see *Change Scan Settings (ControlCenter4) (Windows®)* on page 67).
- Click the **Scan** button.  
The machine starts scanning.

## NOTE

Check the **Don't show me again.** check box to not show the setting dialog box again.

## Scan Plastic Cards

- Load a plastic card (see *Business Cards and Plastic Cards* on page 32).

## NOTE

Load only one plastic card at a time.

- Click the  (ControlCenter4) icon in the task tray and then select **Open** from the menu.  
The **ControlCenter4** window appears.

- 3 Click the **Scan** tab.



- 4 Click the button you want to use (  (**Image**),  (**OCR**),  (**E-mail**),  (**File**), or  (**Print**)). The setting dialog box appears (the example below uses **Image**).

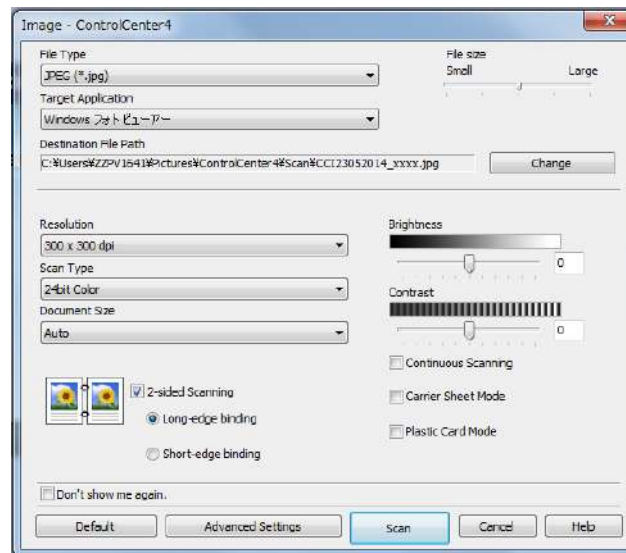

- 5 Select the **Plastic Card Mode** check box.
- 6 Change other settings if needed (see *Change Scan Settings (ControlCenter4) (Windows®)* on page 67).
- 7 Click the **Scan** button.  
The machine starts scanning.

**NOTE**

- Select the **Don't show me again.** check box not to show the setting dialog box again.

- **Plastic Card Mode** automatically uses these settings:

**Resolution: 600 x 600 dpi**

**Document Size: 2 in 1 (Auto)**

**2-sided Scanning: On (Short-edge binding)**

**Auto Deskew: Off**

**Auto Image Rotation: Off**

**Multifeed Detection: Off**

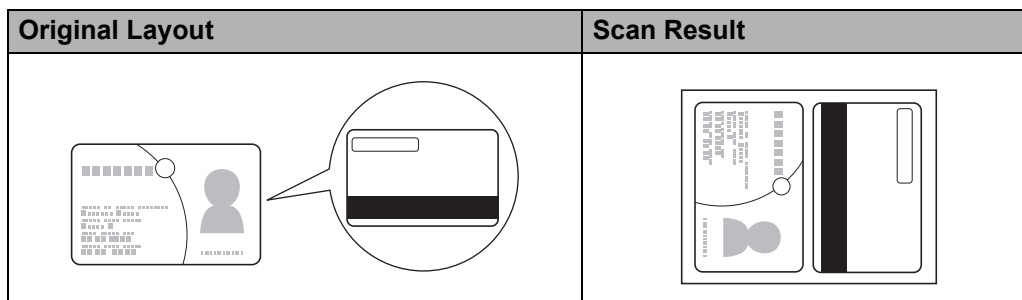
**Scan to an Office File**

Your machine can convert scanned data to a Microsoft® Word file or a Microsoft® PowerPoint® file on your selected Folder or SharePoint. The OCR language is same as the language selected when you installed the ControlCenter4. In order to use this feature, your Brother machine must be connected to a network that has access to the Internet through a wireless or Ethernet connection.

- 1 Load your document (see *Standard-size Documents* on page 30).
- 2 Click the  (ControlCenter4) icon in the task tray and then select **Open** from the menu. The **ControlCenter4** window appears.
- 3 Click the **Scan** tab.



- Click  (**E-mail**) or  (**File**). The setting dialog box appears (the example below uses **E-mail**).

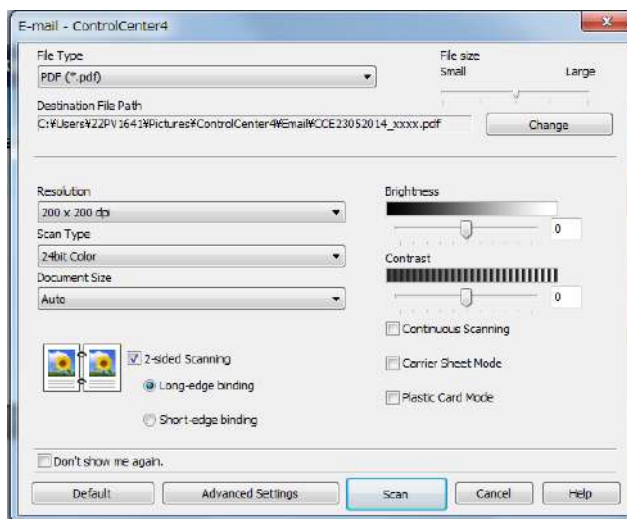

- Click the **File Type** drop-down list, and then select the **Microsoft Office Word (\*.docx)** or **Microsoft Office PowerPoint (\*.pptx)** option.
- Change other settings if needed (see *Change Scan Settings (ControlCenter4) (Windows®)* on page 67).
- Click **Scan**. If a message dialog box regarding the Internet connection appears, read the information and click **OK**.

## Scan Business Cards

- Load your document (see *Business Cards and Plastic Cards* on page 32).
- Click the  (ControlCenter4) icon in the task tray and then select **Open** from the menu. The **ControlCenter4** window appears.
- Click the **Scan** tab.



- 4 Click  (**Image**). The setting dialog box appears.

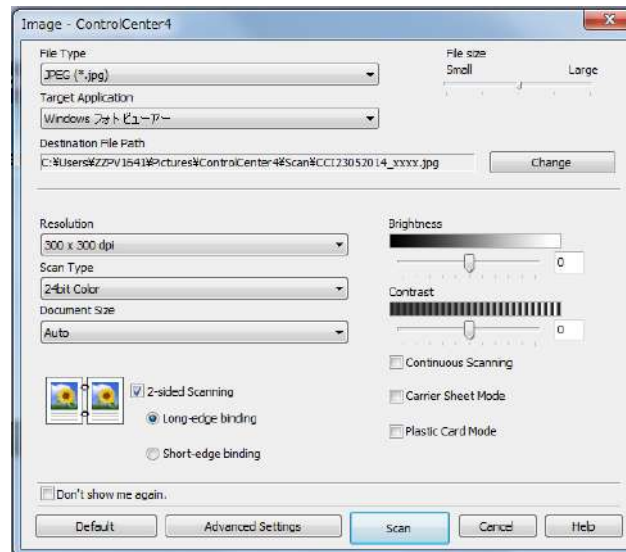

- 5 Select **BizCard MFC Application** from the **Target Application** drop-down list.
- 6 Change other settings if needed (see *Change Scan Settings (ControlCenter4) (Windows®)* on page 67).
- 7 Click **Scan**. The scanned data will be opened in the BizCard 6 application.
- 8 Edit and save the scanned date using BizCard 6.

## Create a Custom Tab (ControlCenter4 Advanced Mode) (Windows®)

You can create up to three customized tabs that include up to five customized buttons with your preferred settings.

### Create a Custom Tab

---

- 1 Click the  (ControlCenter4) icon in the task tray and then select **Open** from the menu. The **ControlCenter4** window appears.



- 2 Click **Configuration** and then select **Create custom tab**. You can also create a custom tab by right-clicking the tab area and selecting **Create custom tab**. A custom tab will be created.



- 3 If you want to change the name of custom tab, right-click the custom tab and select **Rename custom tab**.

### NOTE

You can also change the name of the custom tab by clicking **Configuration** and then **Rename custom tab**.

---

## Create a Custom Button in a Custom Tab

- 1 Create a Custom tab. See *Create a Custom Tab* on page 65.
- 2 Right-click on the new Custom tab, and select **Create custom button**. Select a button you want to create from the menu. The settings dialog box appears.

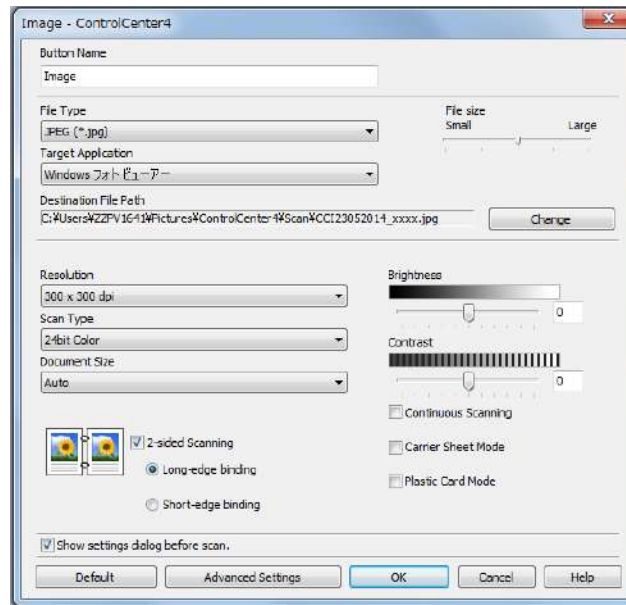

### NOTE

You can also copy a custom button by selecting **Copy custom button** from the menu that appears when you right-click on the Custom tab.

- 3 Type the button name and change the settings if needed. Click **OK**.  
(The setting options vary depending on the button you creat.)



### NOTE

You can change or remove the tab, button, or settings you created. Click **Configuration** and continue as prompted.

## Change Scan Settings (ControlCenter4) (Windows®)

The following settings can be changed.

Setting	Description	Applicable Feature				
		Image	OCR	E-mail	File	Print
<b>File Type</b>	<p>Select the file type you want to use for the scanned data.</p> <p><b>NOTE</b></p> <ul style="list-style-type: none"> <li>To save the document as a password-protected PDF, select <b>Secure PDF (*.pdf)</b> from the <b>File Type</b> drop-down list, click the  (<b>Set PDF Password</b>) button, and enter the password (Image, E-mail and File only).</li> <li>Searchable PDF is a file format that includes the text data layer over a scanned image. This layer allows you to search the text on the image data. The OCR language setting must be set to match the language you want to make the searchable PDF for.</li> <li>To save the document as a searchable PDF, select <b>Searchable PDF (*.pdf)</b> from the <b>File Type</b> drop-down list.</li> <li>To save the document as a searchable PDF, Nuance™ PaperPort™ 12SE must be installed on your computer.</li> <li>To save the document as a high compression PDF, select <b>300 x 300 dpi</b> from the <b>Resolution</b> drop-down list, <b>High Compression PDF (*.pdf)</b> from the <b>File Type</b> drop-down list and <b>True Gray</b> or <b>24bit Color</b> from the <b>Scan Type</b> drop-down list.</li> <li>To save <b>Microsoft Office Word (*.docx)</b> or <b>Microsoft Office PowerPoint (*.pptx)</b>, select <b>E-mail</b> or <b>File</b>.</li> </ul>	Yes	Yes	Yes	Yes	-
<b>Target Application</b>	Select the destination application including Nuance™ PaperPort™ 12SE, Presto! BizCard 6 and Evernote from the drop-down list.	Yes	Yes	-	-	-
<b>OCR Language</b>	Set to match the language of the scanned document's text.	-	Yes	-	-	-
<b>Printer Name</b>	Select the printer you want to use to print the scanned data.	-	-	-	-	Yes
<b>File Name</b>	Click the <b>Change</b> button for <b>Image</b> , <b>OCR</b> or <b>E-mail</b> . Enter a prefix for the file name if needed. Click <b>Insert Date in File Name</b> if needed.	Yes	Yes	Yes	Yes	-
<b>Print Options</b>	Click the <b>Print Options</b> button to configure the printer settings.	-	-	-	-	Yes
<b>Show Save As Window</b>	If you want to specify the destination of the scanned image every time you scan, select the <b>Show Save As Window</b> check box.	-	-	-	Yes	-

Setting	Description	Applicable Feature				
		Image	OCR	E-mail	File	Print
<b>Destination File Path</b>	Click the <b>Change</b> button and then the folder icon to change the folder you would like to save your scanned document to.	Yes	Yes	Yes	-	-
<b>Scan Location</b>	Select one of the Scan Locations: <ul style="list-style-type: none"> <li>• <b>Folder</b> Click the folder icon and browse to the folder you would like to save your scanned document to. Check <b>Show Folder</b> to automatically display the destination folder after scanning.</li> <li>• <b>SharePoint</b> Write the URL address you would like to save your scanned document to. Click <b>Connection Test</b> to confirm the destination.</li> </ul>	-	-	-	Yes	-
<b>File size</b>	Adjust the <b>File size</b> by moving the slider to the right or left.  <b>NOTE</b> <b>File size</b> can be adjusted depending on your selected <b>File Type</b> .	Yes	-	Yes	Yes	-
<b>Resolution</b>	Select a scanning resolution from the <b>Resolution</b> drop-down list. Higher resolutions take more memory and transfer time, but produce a finer scanned image.	Yes	Yes	Yes	Yes	Yes
<b>Scan Type</b>	Select from several color depth options for scanned images. <b>Black &amp; White</b> Use for text or line art images. <b>Gray (Error Diffusion)</b> Use for photographic images or graphics. (Error Diffusion is a method for creating simulated gray images without using true gray dots. Black dots are put in a specific pattern to give a gray appearance.) <b>True Gray</b> Use for photographic images or graphics. This mode is more exact due to using up to 256 shades of gray. <b>24bit Color</b> Uses up to 16.8 million colors to scan the image. Although using <b>24bit Color</b> creates an image with the most accurate color reproduction, it requires the most memory and has the longest transfer time. <b>Auto</b> Automatically selects suitable colors for your document. <sup>1</sup>	Yes	Yes	Yes	Yes	Yes

<sup>1</sup> Depending upon the condition of the original document, this function may not work properly.

Setting	Description	Applicable Feature				
		Image	OCR	E-mail	File	Print
<b>Document Size</b>	<p>Document size is set to <b>Auto</b> by default. You can scan documents of any size without making any adjustments to <b>Document Size</b>.<sup>1</sup> For faster scan speeds, you can select the exact size of your document from the <b>Document Size</b> drop-down list.</p> <p><b>NOTE</b></p> <ul style="list-style-type: none"> <li>• If you select a 1 to 2 document size, the scanned image will be divided into two documents that are half the size of the setting. If you select <b>1 to 2 (A4)</b>, the scanned image will be divided into two A5-size documents.</li> <li>• To do 1 to 2 scanning, unselect the <b>Auto Image Rotation</b> check box in the <b>Advanced Settings</b> dialog box.</li> <li>• If you select a 2 in 1 document size, two scanned images will be combined into one document.</li> <li>• You can select <b>Long Paper</b> when you configure the settings as following: <ul style="list-style-type: none"> <li>• <b>Auto Deskew:</b> Off</li> <li>• <b>2-sided Scanning:</b> Off</li> </ul> </li> <li>• Each <b>Long Paper</b> option can scan a large document up to following: <p><b>Long Paper (Normal Width) 8 1/2 in (215.9 mm):</b> 8 1/2 × 34.0 in. (215.9 × 863.0 mm)</p> <p><b>Long Paper (Narrow Width) 4 1/4 in (107.9 mm):</b> 4 1/4 × 34.0 in. (107.9 × 863.0 mm)</p> </li> </ul>	Yes	Yes	Yes	Yes	Yes
<b>Brightness</b>	<p>Adjust the setting (-50 to 50) to get the best image. The default value of 0 represents an average and is usually suitable for most images. You can set the <b>Brightness</b> level by dragging the slider to the right or left to lighten or darken the image. You can also enter a value in the box to set the level. If the scanned image is too light, set a lower Brightness level and scan the document again. If the image is too dark, set a higher Brightness level and scan the document again.</p>	Yes	Yes	Yes	Yes	Yes

<sup>1</sup> Depending upon the condition of the original document, this function may not work properly.

Setting	Description	Applicable Feature				
		Image	OCR	E-mail	File	Print
<b>Contrast</b>	<p>Adjust the setting (-50 to 50) to get the best image. The default value of 0 represents an average and is usually suitable for most images. You can increase or decrease the contrast level by moving the slider to the right or left. An increase emphasizes dark and light areas of the image, while a decrease reveals more details in gray areas. You can also enter a value in the box to set the <b>Contrast</b>.</p> <p><b>NOTE</b></p> <p>The <b>Contrast</b> setting is only available when setting <b>Scan Type</b> to <b>Auto, Gray (Error Diffusion), True Gray</b> or <b>24bit Color</b>.</p>	Yes	Yes	Yes	Yes	Yes
<b>Continuous Scanning</b>	Scan multiple pages. After the page is scanned, you can select to continue scanning or finish. Using this method, you can scan more pages than the maximum capacity of the ADF.	Yes	Yes	Yes	Yes	Yes
<b>2-sided Scanning</b>	<p>If you select this box, the machine scans both sides of the document. When using the automatic 2-sided (duplex) scan feature, you must select <b>Long-edge binding</b> or <b>Short-edge binding</b> depending on the layout of your original to make sure that the data file created appears correctly in the scanned document.</p> <p><b>NOTE</b></p> <p>The 2-sided (duplex) scanning feature is available with lengths up to Legal size.</p>	Yes	Yes	Yes	Yes	Yes

Setting	Description	Applicable Feature				
		Image	OCR	E-mail	File	Print
<b>Carrier Sheet Mode</b>	<p>Scan the following document types using the Carrier Sheet. For this mode, you can select any setting other than <b>Auto</b> from the <b>Document Size</b> drop-down list.</p> <ul style="list-style-type: none"> <li>■ Large-sized Documents (A3, B4 and Ledger) Fold the document in half and insert it in the Carrier Sheet for 2-sided (duplex) scanning, then both front and back pages will be combined into a single page. Select <b>2 in 1(A4)</b> for an A3 document, <b>2 in 1(B5)</b> for a B4 document or <b>2 in 1(Letter)</b> for a Ledger document from the <b>Document Size</b> drop-down list.</li> <li>■ Important documents (photos, contracts)</li> <li>■ Thin paper (receipts)</li> <li>■ Irregular-shaped paper (clippings)</li> </ul> <p><b>NOTE</b></p> <ul style="list-style-type: none"> <li>• Load only one Carrier Sheet at a time.</li> <li>• Set the document in the center of the Carrier Sheet and align the top of the document with the top of the Carrier Sheet.</li> </ul>	Yes	Yes	Yes	Yes	Yes
<b>Plastic Card Mode</b>	<p>Scan cards, such as driver's licenses or insurance cards, using these automatic settings:</p> <ul style="list-style-type: none"> <li>■ <b>Resolution:</b> 600 x 600 dpi</li> <li>■ <b>Document Size:</b> 2 in 1 (Auto)</li> <li>■ <b>2-sided Scanning:</b> On (<b>Short-edge binding</b>)</li> <li>■ <b>Auto Deskew:</b> Off</li> <li>■ <b>Auto Image Rotation:</b> Off</li> <li>■ <b>Multifeed Detection:</b> Off</li> </ul> <p><b>NOTE</b></p> <ul style="list-style-type: none"> <li>• If you want to scan a plastic card with different settings, set <b>Plastic Card Mode</b> to off and <b>Resolution</b> to 600 dpi.</li> <li>• Load only one plastic card at a time.</li> </ul>	Yes	Yes	Yes	Yes	Yes
<b>Default</b>	Restore all settings to their factory default values.	Yes	Yes	Yes	Yes	Yes

You can configure more settings in the **Advanced Settings** dialog box. Click the **Advanced Settings** button.

Setting	Description	Applicable Feature				
		Image	OCR	E-mail	File	Print
<b>Auto Deskew</b>	Corrects the skew (within 5 degrees) of the scanned data. <sup>1</sup>	Yes	Yes	Yes	Yes	Yes
<b>Auto Image Rotation</b>	Changes the direction of the document based on the text orientation. <sup>1</sup>	Yes	Yes	Yes	Yes	Yes
<b>Bleed Through Prevention/ Remove Background Color</b>	Prevents bleedthrough on a two-sided document, and also allows you to remove the base color of documents such as newspapers to make the scanned data more recognizable. <sup>1</sup>	Yes	Yes	Yes	Yes	Yes
<b>Skip Blank Page</b>	Removes blank pages of the document from the scanning results. <sup>1</sup>	Yes	Yes	Yes	Yes	Yes
<b>Multifeed Detection</b>	Uses a ultrasonic sensor to detect when a multifeed has occurred. When this function detects a multifeed, confirm that the data scanned before the multifeed has been saved, and then start scanning again at the next page or the beginning of the document.	Yes	Yes	Yes	Yes	Yes
<b>Display Scanning Results</b>	Shows the numbers of total pages saved and blank pages skipped on your computer screen.	Yes	Yes	Yes	Yes	Yes

<sup>1</sup> Depending upon the condition of the original document, this function may not work properly.

## Scan Using ControlCenter2 (Macintosh)

ControlCenter2 is a software utility that lets you quickly and easily access your frequently-used applications. Using ControlCenter2 eliminates the need to manually launch specific applications.

There are four scan options: **Scan to Image**, **Scan to OCR**, **Scan to E-mail** and **Scan to File**.

- **Image** (Default: *Apple Preview*)

Lets you scan a page directly into any graphic viewer/editor application. You can choose the destination application, such as Adobe® Photoshop® or any kind of image editing application on your computer.

- **OCR** (Default: *Apple TextEdit*)

Lets you scan a page or document, automatically run the OCR application and put text (not a graphic image) into a word processing application. You can choose the target word processing application, such as Microsoft® Word or any word processing application on your computer. You must install Presto! PageManager on your computer. For installation information, see *Scan Using Presto! PageManager or TWAIN Applications (Macintosh)* on page 109.

- **E-mail** (Default: *your default email software*)

Lets you scan a page or document directly into an email application as a standard attachment. You can choose the file type and resolution for the attachment.



- **File**

Lets you scan directly to a disk file. You can change the file type and destination folder, as needed.

ControlCenter2 gives you the ability to configure the hardware to PC button on your machine and the ControlCenter2 software button for each scan feature. To configure the hardware to PC button on your machine choose the **Device Button** tab in the configuration menu for each of the **SCAN** buttons. To configure the software button in ControlCenter2 choose the **Software Button** tab in the configuration menu for each of the **SCAN** buttons.

To start ControlCenter2, click the  (ControlCenter2) icon in the Dock.



If the  (ControlCenter2) icon is not displayed in the Dock, in the **Finder** menu bar, click **Go > Applications > Brother**, and then double-click the  (ControlCenter2) icon.

The  (ControlCenter2) icon appears in the Dock.

## Scan to Image

The **Scan to Image** feature lets you scan an image directly into your graphics application for image editing. This example uses the Apple Preview application.

1 Click the **SCAN** tab.

2 Click  (**Image**).

The **Scan to Image** dialog box appears.

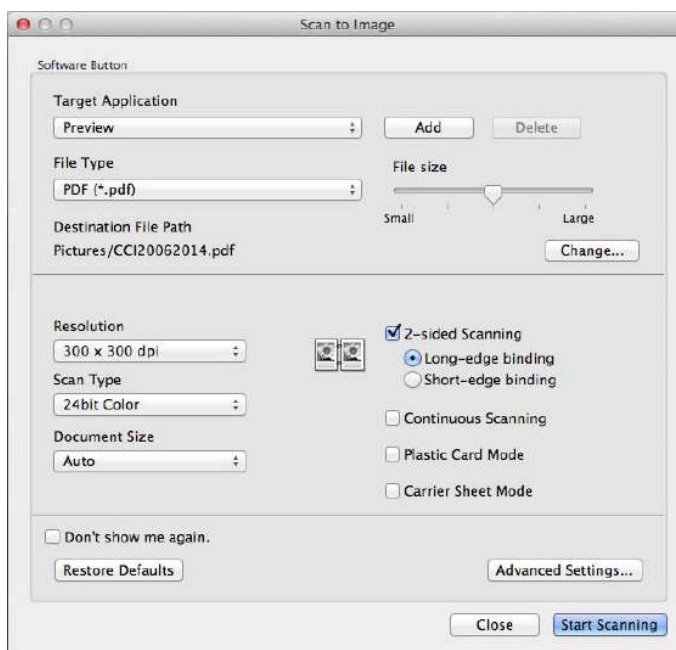

3 Configure the scan settings, if needed.

- To scan a 2-sided document, select the **2-sided Scanning** check box and choose **Long-edge binding** or **Short-edge binding**.
- To change the application that you want to use, choose the appropriate application from the **Target Application** pop-up menu. You can add an application to the list by clicking **Add**. If you want to delete an application, click **Delete**.

4 Click **Start Scanning**.  
Your default application will start and display the image.

### NOTE

If you choose **Secure PDF (\*.pdf)** from the **File Type** list, the **Set PDF Password** dialog box appears. Enter your password in the **Password** and **Re-type Password** boxes, and then click **OK**. You can also choose **Secure PDF (\*.pdf)** for **Scan to E-mail** and **Scan to File**.

## Scan to OCR

The **Scan to OCR** feature lets you convert the graphic page image data into text that can be edited by any word processing application. You can change the default word processing application.

### NOTE

Presto! PageManager must be installed on your computer.

1 Click the **SCAN** tab.

2 Click  (**OCR**).

The **Scan to OCR** dialog box appears.



3 Configure the scan settings, if needed.

- To scan a 2-sided document, select the **2-sided Scanning** check box and choose **Long-edge binding** or **Short-edge binding**.
- To change the word processing application that you want to use, choose the appropriate application from the **Target Application** pop-up menu. You can add an application to the list by clicking **Add**. If you want to delete an application, click **Delete**.

4 Click **Start Scanning**.

Your default word processing application will start and display the converted text data.

## Scan to E-mail

The **Scan to E-mail** feature lets you scan a document to your default email application so you can send the scanned document as an attachment.

1 Click the **SCAN** tab.

2 Click  (**E-mail**).

The **Scan to E-mail** dialog box appears.

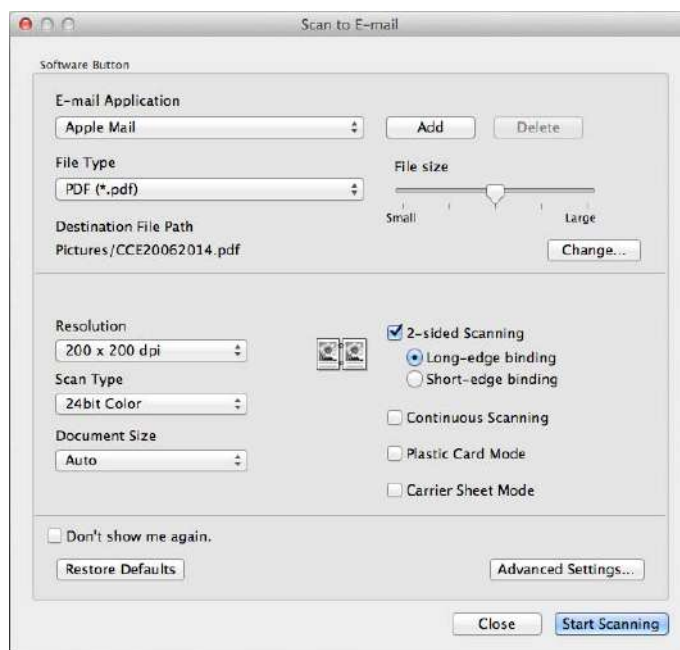

3 Configure the scan settings, if needed.

- To scan a 2-sided document, select the **2-sided Scanning** check box and choose **Long-edge binding** or **Short-edge binding**.
- To change the email application that you want to use, choose the appropriate application from the **E-mail Application** pop-up menu. You can add an application to the list by clicking **Add**<sup>1</sup>. If you want to delete an application, click **Delete**.

<sup>1</sup> When you first start ControlCenter2, a default list of compatible email applications appears in the pop-up menu. If you are having trouble using a custom application with ControlCenter2, you should choose an application from the list.

4 Click **Start Scanning**.

Your default email application will start and the image will be attached to a new email.

### NOTE

The Scan to E-mail feature does not support Webmail services. Use the Scan to Image or Scan to File feature to scan a document or picture, and then attach the file of the scanned data to message.

## Scan to File

The **Scan to File** feature lets you scan an image to a folder on your hard disk in a supported file format. This feature allows you to easily archive your paper documents.

1 Click the **SCAN** tab.

2 Click  (**File**).

The **Scan to File** dialog box appears.

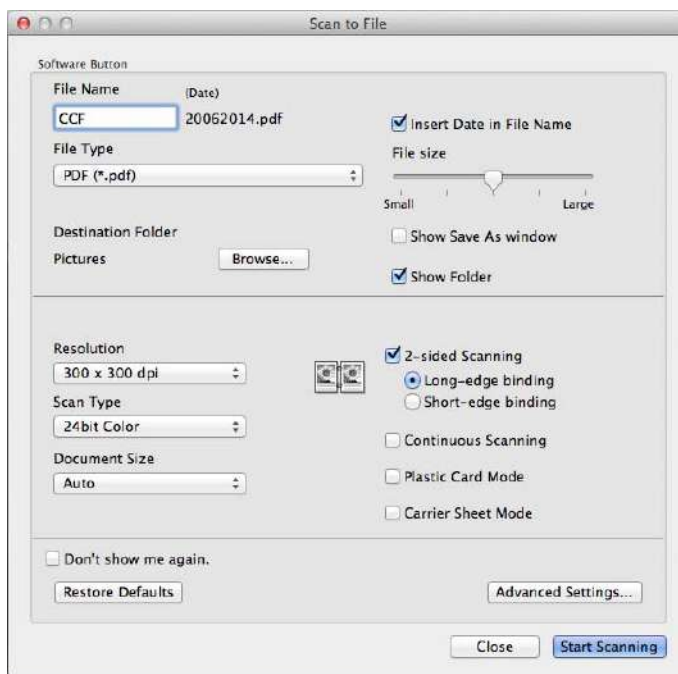

3 Configure the scan settings, if needed.

- To scan a 2-sided document, select the **2-sided Scanning** check box and choose **Long-edge binding** or **Short-edge binding**.
- To change the file name, enter the file name you want to use for the document (up to 100 characters) in the **File Name** box. The file name will be the file name you entered plus the current date and a sequential number.
- Choose the file type for the saved image from the **File Type** pop-up menu. You can save the file to the default folder, or choose your preferred folder by clicking **Browse**.
- To show where the scanned image is saved when scanning is finished, select the **Show Folder** check box. If you want to specify the destination of the scanned image every time, select the **Show Save As window** check box.

4 Click **Start Scanning**.  
The image will be saved in the folder you have chosen.

## Change a Scan Button's Default Settings

- 1 Hold down the **Control** key on your keyboard, and then click the ControlCenter2 scan button that you want to change. When the menu appears, click **Software Button** or **Device Button**. The settings dialog box appears.
- 2 Choose the settings for **File Type**, **Scan Type**, **Document Size**, **Brightness**, **Contrast**, **2-sided Scanning** and **Continuous Scanning** as needed.
- 3 Click **OK**. The new settings will be used as the default settings.

## Scan Specific and Irregular Sized Documents Using the Carrier Sheet

- 1 Load the Carrier Sheet (see *Receipts, Clippings, Photos, and Other Documents* on page 35).



### NOTE

Load only one Carrier Sheet at a time.

- 2 Click the  (ControlCenter2) icon in the Dock. The **ControlCenter2** window appears.



### NOTE

If the  (ControlCenter2) icon is not displayed in the Dock, in the **Finder** menu bar, click **Go > Applications > Brother**, and then double-click the  (ControlCenter2) icon. The  (ControlCenter2) icon appears in the Dock.

- 3 Click the **SCAN** tab, and then click the button for the Scan-to action you want to change (**Image**, **OCR**, **E-mail**, or **File**). The settings dialog box appears (the example below uses **Image**).

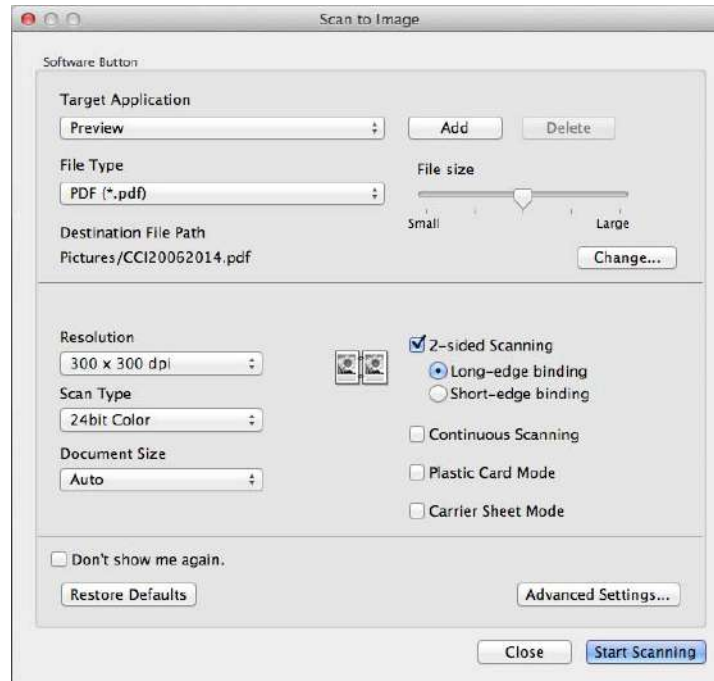

- 4 Select the **Carrier Sheet Mode** check box.
- 5 Select a document size other than **Auto** from the **Document Size** pop-up menu.
- 6 Change other settings if needed (see *Change Scan Settings (ControlCenter2) (Macintosh)* on page 89).
- 7 Click **Start Scanning**.  
Your default application will start and display the image.

## Scan Plastic Cards

- 1 Load a plastic card (see *Business Cards and Plastic Cards* on page 32).

### NOTE

Load only one plastic card at a time.

- 2 Click the  (ControlCenter2) icon in the Dock. The **ControlCenter2** window appears.



- 3 Click the **SCAN** tab, and then click the button for the Scan-to action you want to change (**Image**, **OCR**, **E-mail**, or **File**). The settings dialog box appears (the example below uses **Image**).

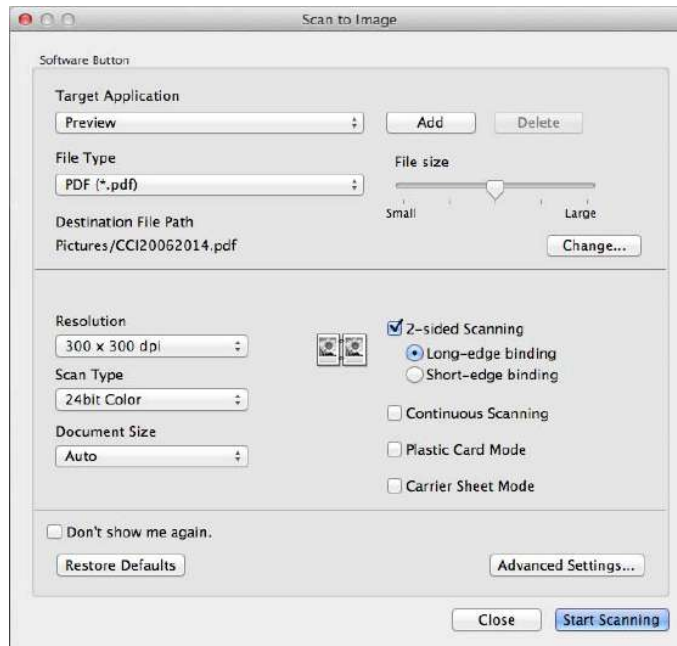

- 4 Click the **Plastic Card Mode** check box.

- 5 Change other settings if needed (see *Change Scan Settings (ControlCenter2) (Macintosh)* on page 89).
- 6 Click **Start Scanning**.  
Your default application will start and display the image.

**NOTE**

- Click the **Don't show me again**. check box not to show the setting dialog box again.
- **Plastic Card Mode** automatically uses these settings:  
**Resolution: 600 x 600 dpi**  
**Document Size: 2 in 1 (Auto)**  
**2-sided Scanning: On (Short-edge binding)**  
**Auto Deskew: On**  
**Auto Image Rotation: Off**  
**Multifeed Detection: Off**

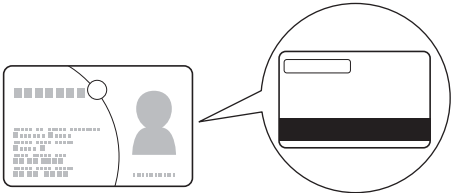
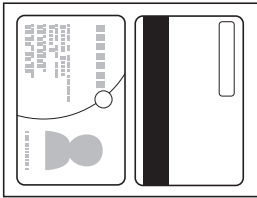
Original Layout	Scan Result
	

## Scan to an Office File

Your machine can convert scanned data to a Microsoft® Word file or a Microsoft® PowerPoint® file. In order to use this feature, your Brother machine must be connected to a network that has access to the Internet through a wireless or Ethernet connection.

- 1 Load your document (see *Standard-size Documents* on page 30).
- 2 Click the  (ControlCenter2) icon in the Dock. The **ControlCenter2** window appears.



- 3 Click the **SCAN** tab.
- 4 Click the **E-mail** or **File** button. The settings dialog box appears (the example below uses **E-mail**).

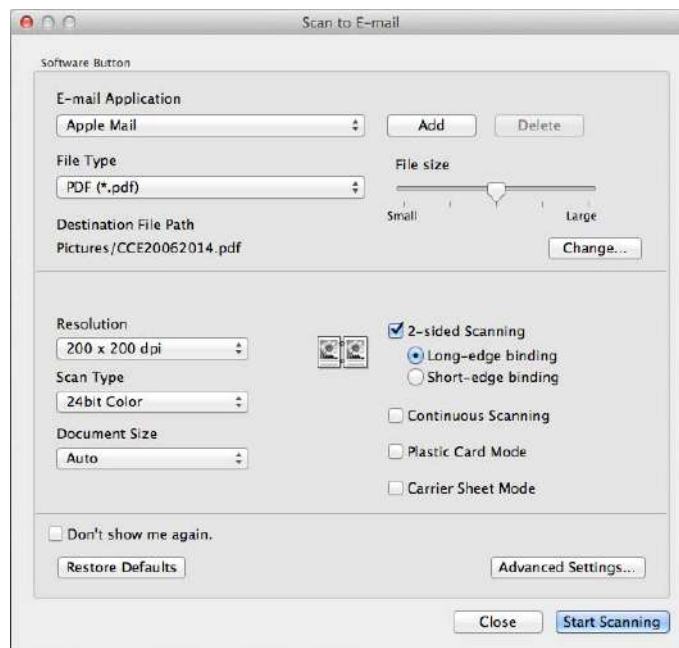

- 5 Click the **File Type** pop-up menu, and then select the **Microsoft Office Word (\*.docx)** or **Microsoft Office PowerPoint (\*.pptx)** option. If a message dialog box regarding the Internet connection appears, read the information and click **OK**.
- 6 Change other settings if needed (see *Change Scan Settings (ControlCenter2) (Macintosh)* on page 89).
- 7 Click **Start Scanning**.

## Scan Business Cards

- 1 Load your document (see *Business Cards and Plastic Cards* on page 32).
- 2 Click the  (ControlCenter2) icon in the Dock. The **ControlCenter2** window appears.



- 3 Click the **SCAN** tab.

- 4 Click the **Image** button. The settings dialog box appears.

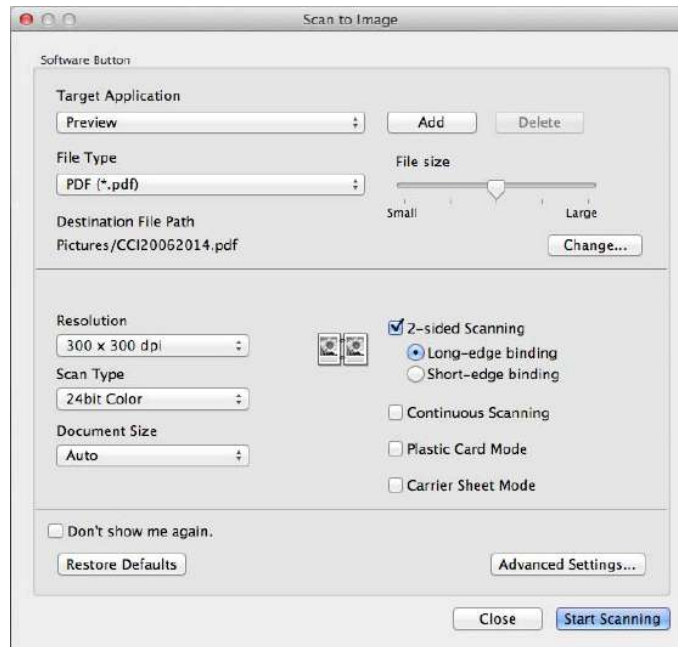

- 5 Select **BizCard 6** from the **Target Application** pop-up menu.
- 6 Change other settings if needed (see *Change Scan Settings (ControlCenter2) (Macintosh)* on page 89).
- 7 Click **Start Scanning**. The scanned data will be opened in the BizCard 6 application.
- 8 Edit and save the scanned date using BizCard 6.

## Register Your Favorite Scan Settings Using ControlCenter2 (Macintosh)

There are four buttons which you can configure to fit your scanning needs.

To customize a button, click the button while holding down the **Control** key, and the configuration window appears. There are four scan functions: **Scan to Image**, **Scan to OCR**, **Scan to E-mail** and **Scan to File**.

### ■ Scan to Image

Lets you scan a page directly into any image viewer/editor software. You can choose any image editor application on your computer as a destination.

### ■ Scan to OCR

Converts scanned documents into editable text files. You can choose the destination application for the editable text. You must install Presto! PageManager on your computer. For installation information see *Scan Using Presto! PageManager or TWAIN Applications (Macintosh)* on page 109.

### ■ Scan to E-mail

Attaches the scanned images to an email message. You can also choose the file attachment type and create a quick send list of email addresses chosen from your email address book.

### ■ Scan to File

Lets you save a scanned image to any folder on a local or network hard disk. You can also choose the file type to be used.



## User-defined Button

---

To customize a button, click the button while holding down the **Control** key, and the configuration window appears. Follow these guidelines for button configuration.

### Scan to Image/OCR/E-mail/File

#### ■ General tab

Enter a name in **Name for Custom** (up to 30 characters) to create the button name.

Choose the type of scan from the **Scan Action** selections.

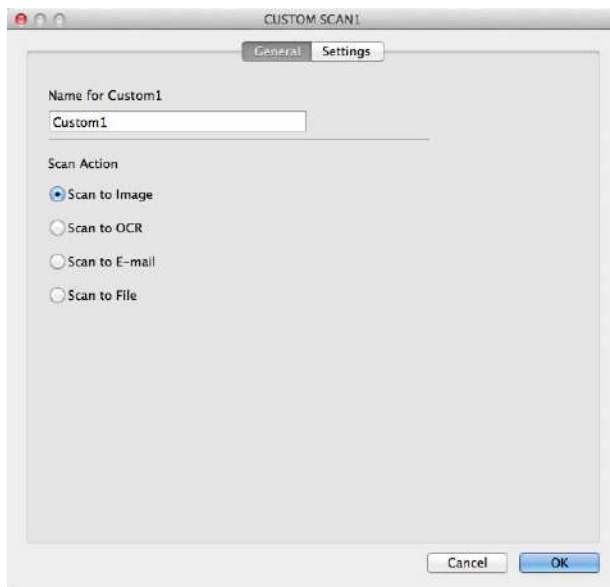

■ **Settings** tab (Scan to Image/OCR/ E-mail)

Choose the **Target Application**, **File Type**, **Resolution**, **Scan Type**, **Document Size** and **2-sided Scanning** settings.

**NOTE**

The Scan to E-mail feature does not support Webmail services. Use the Scan to Image or Scan to File feature to scan a document or picture, and then attach the file of the scanned data to an email message.

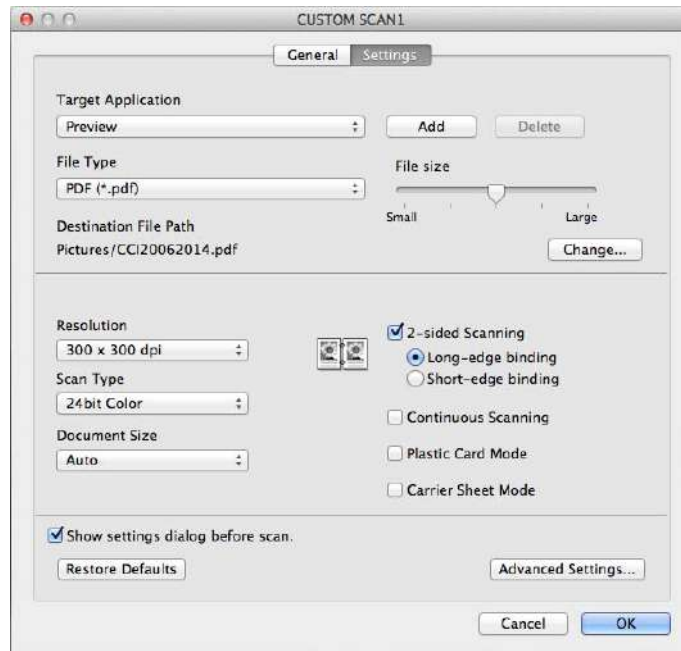

If you choose **Secure PDF (\*.pdf)** from the **File Type** list, the **Set PDF Password** dialog box appears. Enter your password in the **Password** and **Re-type Password** box and then click **OK**.

**NOTE**

**Secure PDF (\*.pdf)** is available for Scan to Image, Scan to E-mail and Scan to File.

■ **Settings** tab (Scan to File)

Choose the file format from the **File Type** pop-up menu. Save the file to the default folder or choose your preferred folder by clicking the **Browse** button.

Choose the **Resolution**, **Scan Type**, **Document Size** and **2-sided Scanning** settings.

If you want to specify the destination of the scanned image, select the **Show Save As window** check box.



## Change Scan Settings (ControlCenter2) (Macintosh)

The following settings can be changed.

Setting	Description	Applicable Feature			
		Image	OCR	E-mail	File
<b>Target Application</b> (for Image, OCR and File) or <b>E-mail Application</b> (for email)	<p>Select which application is used to open scanned data. Only applications installed on your computer (including Presto! PageManager, Presto! BizCard 6 and Evernote) can be selected.</p> <ul style="list-style-type: none"> <li>■ <b>Add</b> button            Add an application to the pop-up menu. Enter the <b>Application Name</b> (up to 30 characters) and select your preferred application by clicking the <b>Browse</b> button. Also select the <b>File Type</b> from the pop-up menu.</li> <li>■ <b>Delete</b> button            Delete an application that you have added. Select the <b>Application Name</b> and click the <b>Delete</b> button.</li> </ul>	Yes	Yes	Yes	-

Setting	Description	Applicable Feature			
		Image	OCR	E-mail	File
<b>File Type</b>	<p>Select the file type you want to use for the scanned data.</p> <p><b>NOTE</b></p> <ul style="list-style-type: none"> <li>To save the document as a password-protected PDF, select <b>Secure PDF (*.pdf)</b> for <b>File Type</b> and then enter the password in the <b>Set PDF Password</b> dialog box (Image, E-mail and File only).</li> <li>Searchable PDF is a file format that includes the text data layer over a scanned image. This layer allows you to search the text on the image data. The OCR language setting must be set to match the language you want to make the searchable PDF for.</li> <li>To save the document as a searchable PDF, select <b>Searchable PDF (*.pdf)</b> from the <b>File Type</b> drop-down list.</li> <li>To save the document as a searchable PDF, Presto! PageManager must be installed on your computer. See <i>Installing Presto! PageManager</i> on page 109.</li> <li>To save the document as a high compression PDF, select <b>300 x 300 dpi</b> from the <b>Resolution</b> pop-up menu, <b>High Compression PDF (*.pdf)</b> from the <b>File Type</b> pop-up menu and <b>True Gray</b> or <b>24bit Color</b> from the <b>Scan Type</b> pop-up menu.</li> <li>Several file types such as TIFF, TIFF Multi-Page, PDF, Secure PDF and JPEG support file size compression. Select <b>Uncompressed</b> or <b>Compressed</b> to adjust the file size for TIFF or TIFF Multi-Page. For PDF, Secure PDF and JPEG, use the slider to adjust the file size (not available for Scan to OCR).</li> </ul>	Yes	Yes	Yes	Yes
<b>File size</b>	<p>Adjust the <b>File size</b> by moving the slider to the right or left.</p> <p><b>NOTE</b></p> <p><b>File size</b> can be adjusted depending on your selected <b>File Type</b>.</p>	Yes	-	Yes	Yes
<b>OCR Software</b>	Shows the application that will convert the scanned image to editable text.	-	Yes	-	-
<b>OCR Language</b>	Set to match the language of the scanned document's text.	-	Yes	-	-
<b>File Name</b>	Enter a prefix for the file name if needed.	Yes	Yes	Yes	Yes
<b>Show Save As window</b>	If you want to specify the destination of the scanned image every time you scan, select the <b>Show Save As window</b> check box.	-	-	-	Yes

Setting	Description	Applicable Feature			
		Image	OCR	E-mail	File
<b>Destination File Path</b>	Click the <b>Change</b> button and then the <b>Browse</b> button to change the folder you would like to save your scanned document to.	Yes	Yes	Yes	-
<b>Destination Folder</b>	Click <b>Browse</b> and browse to the folder you would like to save your scanned document to. Check <b>Show Folder</b> to automatically display the destination folder after scanning.	-	-	-	Yes
<b>Resolution</b>	Select a scanning resolution from the <b>Resolution</b> pop-up menu. Higher resolutions take more memory and transfer time, but produce a finer scanned image.	Yes	Yes	Yes	Yes
<b>Scan Type</b>	<p>Select from a range of scan color depth.</p> <p><b>Black &amp; White</b> Use for text or line art images.</p> <p><b>Gray (Error Diffusion)</b> Use for photographic images or graphics. (Error Diffusion is a method for creating simulated gray images without using true gray dots. Black dots are put in a specific pattern to give a gray appearance.)</p> <p><b>True Gray</b> Use for photographic images or graphics. This mode is more exact due to using up to 256 shades of gray.</p> <p><b>24bit Color</b> Uses up to 16.8 million colors to scan the image. Although using <b>24bit Color</b> creates an image with the most accurate color reproduction, it requires the most memory and has the longest transfer time.</p> <p><b>Auto</b> Uses suitable colors for your document automatically. <sup>1</sup></p>	Yes	Yes	Yes	Yes

<sup>1</sup> Depending upon the condition of the original document, this function may not work properly.

Setting	Description	Applicable Feature			
		Image	OCR	E-mail	File
<b>Document Size</b>	<p>Document size is set to <b>Auto</b> by default. You can scan documents of any size without making any adjustments to <b>Document Size</b>.<sup>1</sup> For faster scan speeds, you can select the exact size of your document from the <b>Document Size</b> pop-up menu.</p> <p><b>NOTE</b></p> <ul style="list-style-type: none"> <li>If you select a 1 to 2 document size, the scanned image will be divided into two documents that are half the size of the setting. If you select <b>1 to 2 (A4)</b>, the scanned image will be divided into two A5-size documents.</li> <li>To do 1 to 2 scanning or 2 in 1 scanning, unselect the <b>Auto Image Rotation</b> check box in the <b>Advanced Settings</b> dialog box.</li> <li>If you select a 2 in 1 document size, two scanned images will be combined into one document.</li> <li>You can select <b>Long Paper</b> when you configure the settings as following: <ul style="list-style-type: none"> <li><b>Auto Deskew:</b> Off</li> <li><b>2-sided Scanning:</b> Off</li> </ul> </li> </ul>	Yes	Yes	Yes	Yes
<b>2-sided Scanning</b>	<p>If you check this box, the machine scans both sides of the document. When using the automatic 2-sided (duplex) scan feature, you must select <b>Long-edge binding</b> or <b>Short-edge binding</b>, depending on the layout of your original, to make sure that the data file created appears correctly in the scanned document.</p> <p><b>NOTE</b></p> <p>The 2-sided (duplex) scanning feature is available with lengths up to Legal size.</p>	Yes	Yes	Yes	Yes
<b>Restore Defaults</b>	Restore all settings to their factory default values.	Yes	Yes	Yes	Yes
<b>Continuous Scanning</b>	Scan multiple batches of documents and put them together into one data file. After the first batch of documents is scanned, click <b>Continue</b> for additional pages or <b>Finish</b> . This operation enables you to scan more sheets than the maximum capacity of the ADF.	Yes	Yes	Yes	Yes

<sup>1</sup> Depending upon the condition of the original document, this function may not work properly.

Setting	Description	Applicable Feature			
		Image	OCR	E-mail	File
<b>Carrier Sheet Mode</b>	<p>You can scan the following documents using the Carrier Sheet. For this mode, you can select any setting other than <b>Auto</b> from the <b>Document Size</b> pop-up menu.</p> <ul style="list-style-type: none"> <li>■ Large-sized Documents (A3, B4 and Ledger) Fold the document in half and insert it in the Carrier Sheet for 2-sided (duplex) scanning, then both front and back pages will be combined into a single page. Select <b>2 in 1 (A4)</b> for an A3 document, <b>2 in 1 (B5)</b> for a B4 document or <b>2 in 1 (Letter)</b> for a Ledger document from the Document Size pop-up menu.</li> <li>■ Important documents (photos, contracts)</li> <li>■ Thin paper (receipts)</li> <li>■ Irregular-shaped paper (clippings)</li> </ul> <p><b>NOTE</b></p> <ul style="list-style-type: none"> <li>• Load only one Carrier Sheet at a time.</li> <li>• Set the document in the center of the Carrier Sheet and align the top of the document with the top of the Carrier Sheet.</li> </ul>	Yes	Yes	Yes	Yes
<b>Plastic Card Mode</b>	<p>Scan cards, such as driver's licenses or insurance cards, using these automatic settings:</p> <ul style="list-style-type: none"> <li>■ <b>Resolution: 600 x 600 dpi</b></li> <li>■ <b>Document Size: 2 in 1 (Auto)</b></li> <li>■ <b>2-sided Scanning: On (Short-edge binding)</b></li> <li>■ <b>Auto Deskew: On</b></li> <li>■ <b>Auto Image Rotation: Off</b></li> <li>■ <b>Multifeed Detection: Off</b></li> </ul> <p><b>NOTE</b></p> <ul style="list-style-type: none"> <li>• If you want to scan a plastic card with different settings, set <b>Plastic Card Mode</b> to off and <b>Resolution</b> to 600 dpi.</li> <li>• Load only one plastic card at a time.</li> </ul>	Yes	Yes	Yes	Yes

You can configure more settings in the **Advanced Settings** dialog box. Click the **Advanced Settings** button.

Setting	Description	Applicable Feature			
		Image	OCR	E-mail	File
<b>Brightness</b>	Adjust the setting (0 to 100) to get the best image. The default value of 50 represents an average and is usually suitable for most images. You can set the <b>Brightness</b> level by dragging the slider to the right or left to lighten or darken the image. If the scanned image is too light, set a lower Brightness level and scan the document again. If the image is too dark, set a higher Brightness level and scan the document again.	Yes	Yes	Yes	Yes
<b>Contrast</b>	Adjust the setting (0 to 100) to get the best image. The default value of 50 represents an average and is usually suitable for most images. You can increase or decrease the contrast level by moving the slider to the right or left. An increase emphasizes dark and light areas of the image, while a decrease reveals more details in gray areas.  <b>NOTE</b> The <b>Contrast</b> setting is only available when setting <b>Scan Type to Auto, Gray (Error Diffusion), True Gray or 24bit Color.</b>	Yes	Yes	Yes	Yes
<b>Color Drop</b>	Deletes specific colors from your scan data. Select one of the following:  ■ <b>Chromatic colors</b> Use to drop all colors except Black.  ■ <b>Red</b> Use to drop the Red color.  ■ <b>Green</b> Use to drop the Green color.  ■ <b>Blue</b> Use to drop the Blue color.  ■ <b>Custom</b> Select the color that you want to remove.	Yes	Yes	Yes	Yes

Setting	Description	Applicable Feature			
		Image	OCR	E-mail	File
<b>Auto Deskew</b>	Corrects the skew (within 5 degrees) of the scanned data. <sup>1</sup>	Yes	Yes	Yes	Yes
<b>Auto Image Rotation</b>	Changes the direction of the document based on the text orientation. <sup>1</sup>	Yes	Yes	Yes	Yes
<b>Bleed Through Prevention/ Remove Background Color</b>	Prevents the Bleed Through phenomenon on a two-sided document, and also allows you to remove the base color of documents such as newspapers to make the scanned data more recognizable. <sup>1</sup>	Yes	Yes	Yes	Yes
<b>Skip Blank Page</b>	Removes blank pages of the document from the scanning results. <sup>1</sup>	Yes	Yes	Yes	Yes
<b>Multifeed Detection</b>	Uses a ultrasonic sensor to detect when a multifeed has occurred. When this function detects a multifeed, confirm that the data scanned before the multifeed has been saved, and then start scanning again at the next page or the beginning of the document.	Yes	Yes	Yes	Yes
<b>Display Scanning Results</b>	Shows the numbers of total pages saved and blank pages skipped on your computer screen.	Yes	Yes	Yes	Yes

<sup>1</sup> Depending upon the condition of the original document, this function may not work properly.

# Scan Using Nuance™ PaperPort™ 12SE or Other Windows® Applications

## Scan Using Nuance™ PaperPort™ 12SE

---

You can use the Nuance™ PaperPort™ 12SE application, which is included in the Brother MFL-Pro software suite, for scanning. Nuance™ PaperPort™ 12SE supports both TWAIN and WIA drivers; the TWAIN driver (recommended) is used in the example on this page. For an example using the WIA driver, see *Scan Using Windows® Photo Gallery or Windows® Fax and Scan* on page 106.

### NOTE

---

- Nuance™ PaperPort™ 12SE supports Windows® XP (SP3 or later), Windows Vista® (SP2 or later), Windows® 7, Windows® 8 and Windows® 8.1.
  - The WIA driver with Windows® XP (SP2 or later) does not support 2-sided (duplex) scanning.
  - For more information about the application refer to the Nuance™ PaperPort™ 12SE help file. You can access this from the Nuance™ PaperPort™ 12SE **Help** menu.
- 

These instructions are for Nuance™ PaperPort™ 12SE, but are similar for other Windows® applications.

- 1 Load your document.

2 Start Nuance™ PaperPort™ 12SE. Do one of the following:

- (Windows® XP, Windows Vista® and Windows® 7)

Click  (**Start**) > **All Programs** > **Nuance PaperPort12** > **PaperPort**.

- (Windows® 8 and Windows® 8.1)

Click  (**PaperPort**).

The Nuance™ PaperPort™ 12SE window appears.

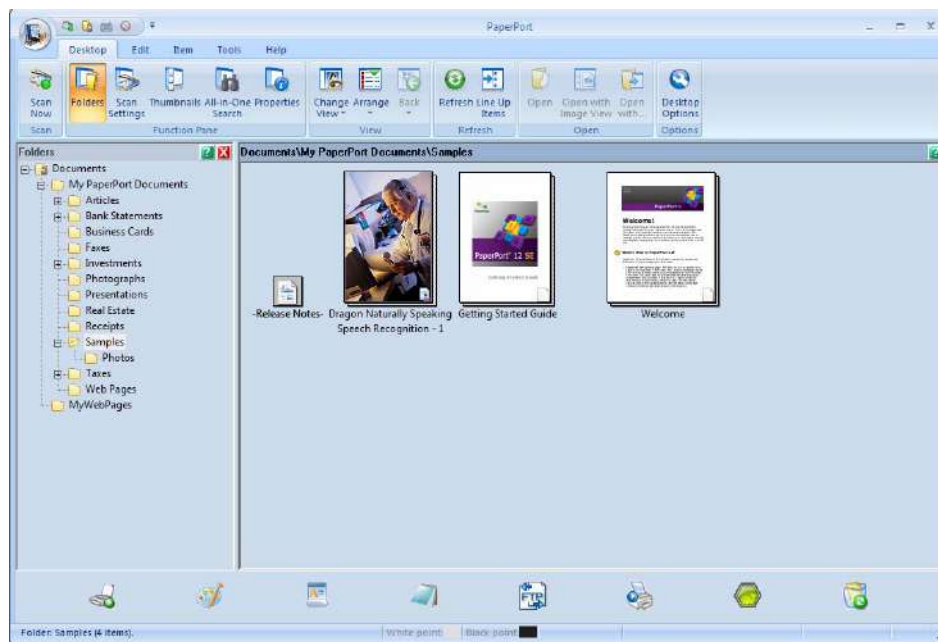

- Click **Scan Settings** from the **Desktop** tab on the ribbon. The **Scan or Get Photo** panel appears on the left side of the window.

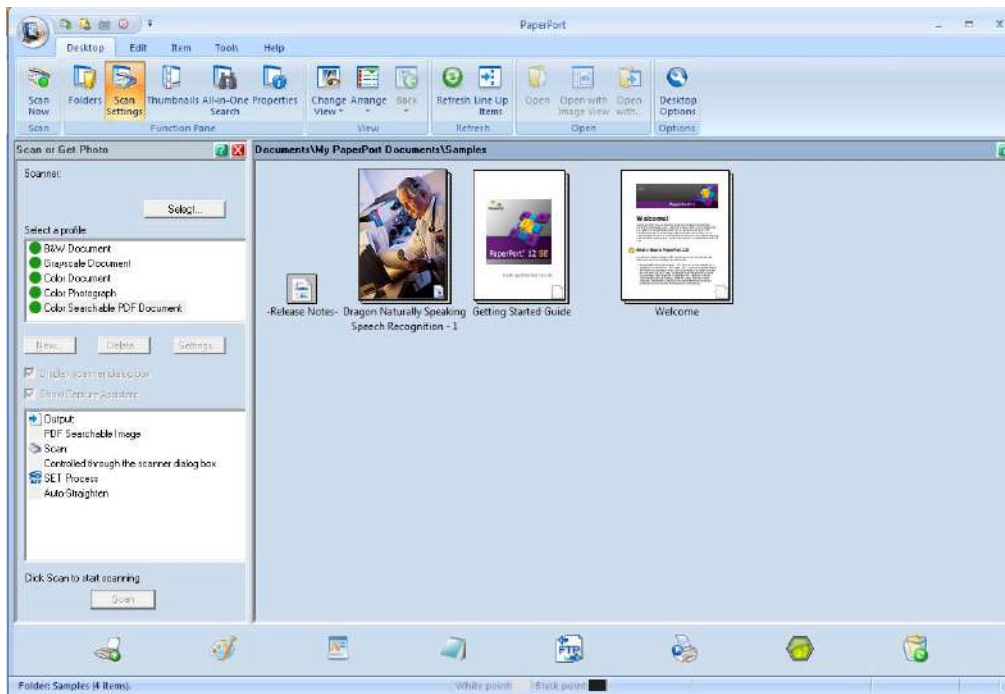

- Click the **Select** button.
- From the **Available Scanners** list, select **TWAIN: TW-Brother ADS-XXXXX** or **TWAIN: TW-Brother ADS-XXXXX LAN** (where ADS-XXXXX is the model name of your machine). If you want to use the WIA driver, select the Brother driver that has “WIA” as the prefix. Click **OK**.
- Select the **Display scanner dialog box** check box in the **Scan or Get Photo** panel.
- Click the **Scan** button. The **Scanner Setup** dialog box appears.

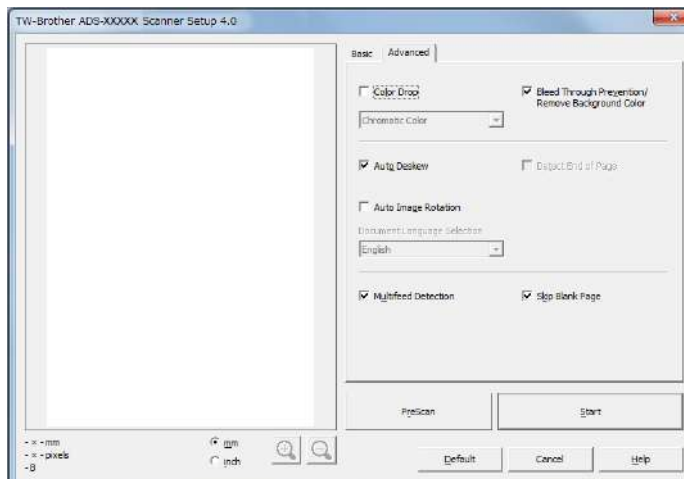

- 8 Adjust the settings in the **Scanner Setup** dialog box if needed (**Resolution**, **Scan Type**, **Brightness**, and **Contrast**).
  - For more information about *TWAIN Driver Settings*, see page 100.
  - For more information about *WIA Driver Settings*, see page 105.
- 9 From the **Document Size** drop-down list, select your document size.

---

**NOTE**

After you select a document size, you can adjust the scanning area further by clicking the left mouse button and dragging it. This is required when cropping an image for scanning.

---

- 10 Click the **Start** button.  
The machine starts scanning.

## TWAIN Driver Settings

Click either the **Basic** tab or the **Advanced** tab for TWAIN driver settings.

### ■ Basic tab

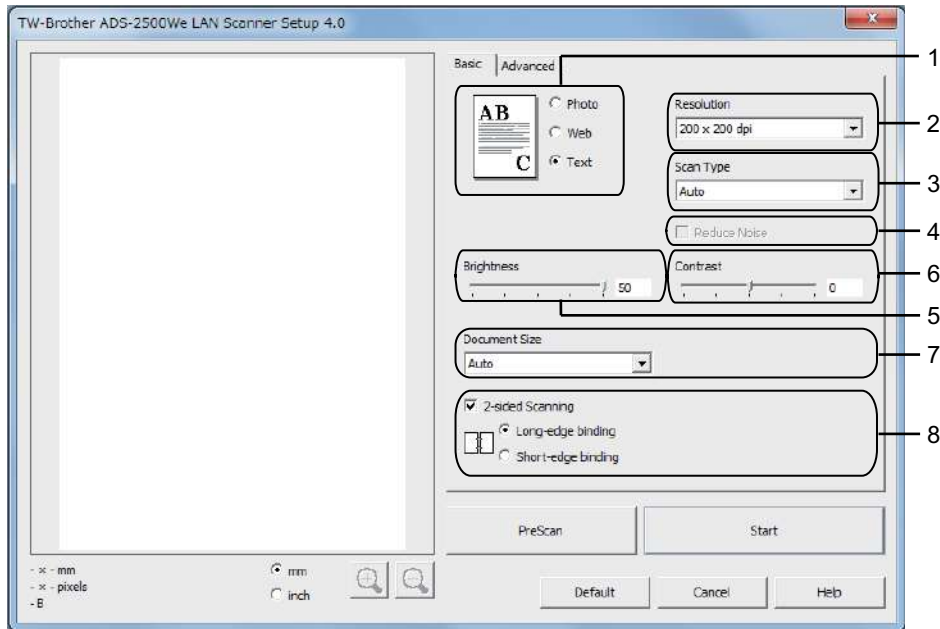

### 1 Scan (Image Type)

Select **Photo**, **Web**, or **Text**.

Scan (Image Type)		Resolution	Scan Type
<b>Photo</b>	Use for scanning photo images	300 x 300 dpi	24bit Color
<b>Web</b>	Use for attaching the scanned image to web pages	100 x 100 dpi	24bit Color
<b>Text</b>	Use for scanning text documents	200 x 200 dpi	Black & White

### 2 Resolution

Select a scanning resolution from the **Resolution** drop-down list. Higher resolutions take more memory and transfer time, but produce a finer scanned image.

Resolution
100 x 100 dpi
150 x 150 dpi
200 x 200 dpi
300 x 300 dpi
400 x 400 dpi
600 x 600 dpi
1,200 x 1,200 dpi

### 3 Scan Type

Select one of the following:

- **Auto**

- **Black & White**

Use for text or line art images.

- **Gray (Error Diffusion)**

Use for photographic images or graphics. (Error Diffusion is a method for creating simulated gray images without using true gray dots. Black dots are put in a specific pattern to give a gray appearance.)

- **True Gray**

Use for photographic images or graphics. This mode is more exact due to using up to 256 shades of gray.

- **24bit Color**

Uses up to 16.8 million colors to scan the image. Although using **24bit Color** creates an image with the most accurate color reproduction, it requires the most memory and has the longest transfer time.

### 4 Reduce Noise

You can improve and enhance the quality of your scanned images with this selection. The Reduce Noise setting is available when using **24bit Color** and scan resolutions of 300 x 300 dpi, 400 x 400 dpi or 600 x 600 dpi.

### 5 Brightness

Adjust the setting (-50 to 50) to get the best image. The default value of 0 represents an average and is usually suitable for most images. You can set the **Brightness** level by dragging the slider to the right or left to lighten or darken the image. You can also enter a value in the box to set the level. If the scanned image is too light, set a lower Brightness level and scan the document again. If the image is too dark, set a higher Brightness level and scan the document again.

### 6 Contrast

Adjust the setting (-50 to 50) to get the best image. The default value of 0 represents an average and is usually suitable for most images. You can increase or decrease the contrast level by moving the slider to the right or left. An increase emphasizes dark and light areas of the image, while a decrease reveals more details in gray areas. You can also enter a value in the box to set the **Contrast**.

## NOTE

The **Contrast** setting is only available when setting **Scan Type** to **Gray (Error Diffusion)**, **True Gray** or **24bit Color** or **Auto**.



### 7 Document Size

Document size is set to **Letter** by default. For faster scan speeds, you can select the exact size of your document from the **Document Size** drop-down list. If you select **Custom**, the **Custom Document Size** dialog box appears in which you can specify the document size.

You can select **Long Paper** when **Auto Deskew** and **2-sided Scanning** are off.

### 8 2-sided Scanning

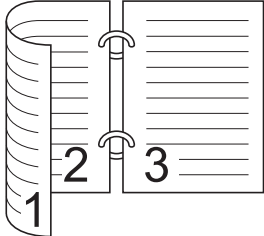
Select **Long-edge binding** or **Short-edge binding** depending on the layout of your original to make sure that the data file created appears correctly in the scanned document.

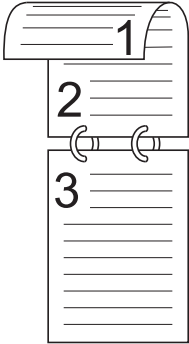
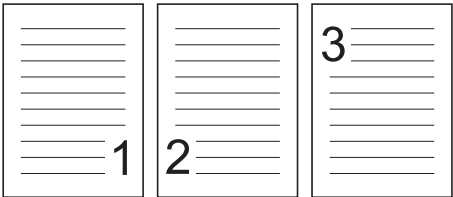
2-sided Scan Setting	Original Layout	Scan Result
<p><b>Long-edge binding</b></p>		
<p><b>Short-edge binding</b></p>		

## ■ Advanced tab

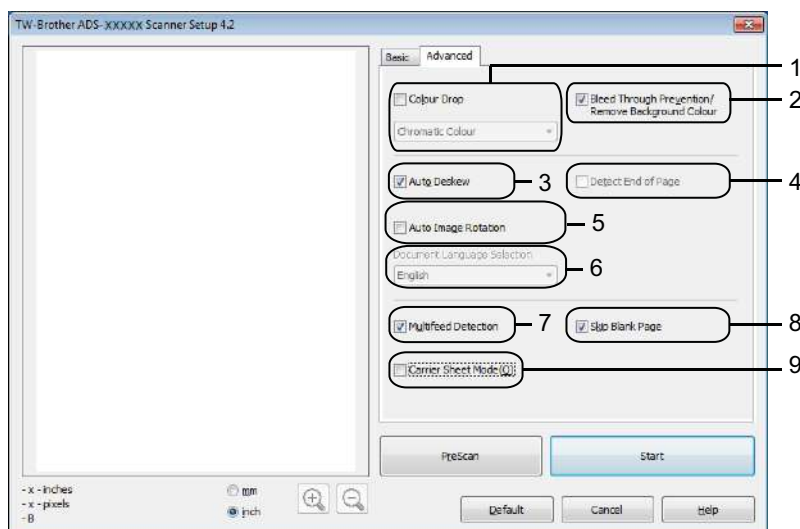

### 1 Color Drop

Deletes specific colors from your scan data.

Select one of the following:

#### ■ Chromatic colors

Use to drop all colors except Black.

#### ■ Red

Use to drop the Red color.

#### ■ Green

Use to drop the Green color.

#### ■ Blue

Use to drop the Blue color.

#### ■ Custom

Select the color that you want to remove.

### 2 Bleed Through Prevention/Remove Background Color

Prevents the Bleed Through phenomenon on a two-sided document, and remove the base color of documents such as newspapers to make the scanned data more recognizable.

### 3 Auto Deskew

Corrects the skew (within 5 degrees) of the scanned data.

### 4 Detect end of page

Detects end of page and automatically adjusts the size of a page when the length of the document is shorter than the **Document Size** selected.

This function is available when the document size is a size other than **Auto** or **Long Paper**.

### 5 Auto Image Rotation

Changes the direction of the document based on the text orientation.

### 6 Document Language Selection

If you selected **Auto Image Rotation** (see 5, above), specify the document's language.

## 7 Multifeed Detection

Uses a ultrasonic sensor to detect when a multifeed has occurred. When this function detects a multifeed, confirm that the data scanned before the multifeed has been saved, and then start scanning again at the next page or the beginning of the document.

## 8 Skip Blank Page

Removes blank pages of the document from the scanning results.

## 9 Carrier Sheet Mode

Scan the following document types using the Carrier Sheet.

For this mode, you can select any settings other than **Auto** from the **Document Size** drop-down list.

- Important documents (photos, contracts)
- Thin paper (receipts)
- Irregular-shaped paper (clippings)

## NOTE

---

- Load only one Carrier Sheet at a time.
  - Set the document in the center of the Carrier Sheet and align the top of the document with the top of the Carrier Sheet.
-

## WIA Driver Settings

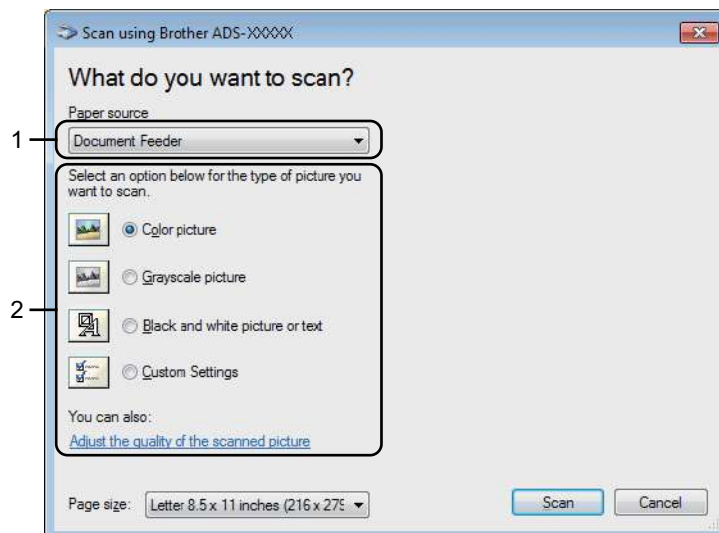

### 1 Paper source

You can select **Document Feeder** only.

### 2 Picture Type (Image Type)

Select **Color picture**, **Grayscale picture**, **Black and white picture or text**, or **Custom Settings**.

To change advanced settings, click **Adjust the quality of the scanned picture**.

#### ■ Resolution

Select a scanning resolution from the **Resolution** text box. Higher resolutions take more memory and transfer time, but produce a finer scanned image.

#### ■ Brightness

Adjust the setting (-50 to 50) to get the best image. The default value of 0 represents an average and is usually suitable for most images. You can set the **Brightness** level by dragging the slider to the right or left to lighten or darken the image. You can also enter a value in the box to set the level. If the scanned image is too light, set a lower Brightness level and scan the document again. If the image is too dark, set a higher Brightness level and scan the document again.

#### ■ Contrast

Adjust the setting (-50 to 50) to get the best image. The default value of 0 represents an average and is usually suitable for most images. You can increase or decrease the contrast level by moving the slider to the right or left. An increase emphasizes dark and light areas of the image, while a decrease reveals more details in gray areas. You can also enter a value in the box to set the **Contrast**.

## Scan Using Windows® Photo Gallery or Windows® Fax and Scan

You can use the Windows® Photo Gallery or Windows® Fax and Scan applications for scanning. These applications use the WIA scanner driver. The steps below will guide you through the scanning operations. You may need to download Windows® Photo Gallery or Windows® Fax and Scan.

- 1 Load your document.
- 2 Open your software application to scan the document. Do one of the following:
  - (Windows® Photo Gallery)
    - 1 Click **File**, then **Import from Camera or Scanner**.
    - 2 Select the scanner you want to use.
    - 3 Click the **Import** button.  
The settings dialog box appears.
  - (Windows® Fax and Scan)  
Click **File > New > Scan**.  
The settings dialog box appears.

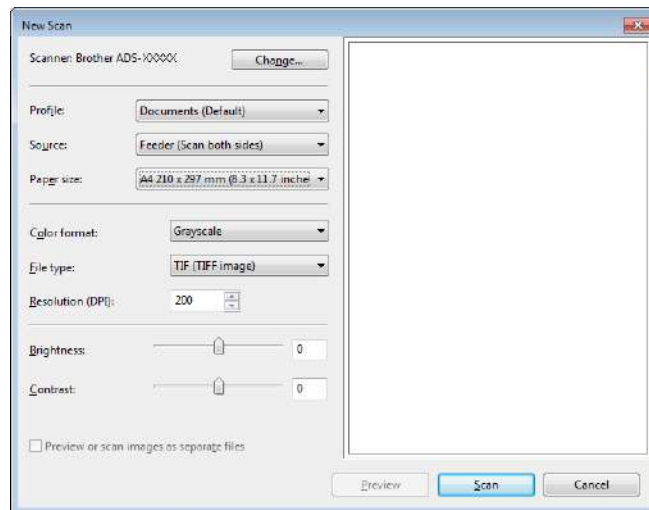

- 3 Adjust the settings in the settings dialog box if needed.
- 4 Click the **Scan** button.  
The machine starts scanning.

## Use Nuance PDF Converter Professional 8 (Windows®)

Nuance PDF Converter Professional 8 offers a variety of features for handling PDF files. It can unlock and open PDF files for viewing, editing, annotation and re-assembly.

### Installing Nuance PDF Converter Professional 8

---

- 1 Insert the supplied DVD-ROM into your DVD-ROM drive.
- 2 When the Brother Installation screen appears, select your model name and then the desired language.
- 3 Click **Additional Applications**.
- 4 Click the **Nuance PDF Converter Professional 8** button. Follow the on-screen instructions.

For information about how to scan using Nuance PDF Converter Professional 8, see the Nuance PDF Converter Professional 8 help by clicking on **Help** on the menu bar, then **Help**.

#### NOTE

---

- Enter the Nuance serial number that is shown on the “sleeve” of the MFL-Pro Suite DVD-ROM package when installing Nuance PDF Converter Professional 8.
  - You will need the password to unlock PDF files.
-

## Use NewSoft Presto! BizCard 6 (Windows®)

Presto! BizCard lets you manage the information, such as names, companies, mailing addresses, phone/fax numbers and email addresses, from scanned business cards to your computer. Scan or import your business cards and Presto! BizCard automatically saves the data and image for each card. Different viewing modes are available for searching, editing, creating, and sorting.

### Installing NewSoft Presto! BizCard 6

---

- 1 Insert the supplied DVD-ROM into your DVD-ROM drive.
- 2 When the Brother Installation screen appears, select your model name and then the desired language.
- 3 Click **Additional Applications**.
- 4 Click the **NewSoft Presto! BizCard 6** button. Follow the on-screen instructions.

For information about how to scan using Presto! BizCard 6, see the **Presto! BizCard User's Manual**. Do one of the following:

- (Windows® XP, Windows Vista® and Windows® 7)

Click  (**Start**) > **All Programs** > **NewSoft** > **Presto! BizCard 6** > **Presto! BizCard 6**.

- (Windows® 8 and Windows® 8.1)

Click  (**Presto! BizCard 6**).

## Scan Using Presto! PageManager or TWAIN Applications (Macintosh)

You can use the Presto! PageManager application for scanning. These instructions for scanning are for Presto! PageManager but are similar for other applications that support TWAIN specifications.

### Installing Presto! PageManager

---

- 1 Download the full driver and software package from the Brother Solutions Center (<http://support.brother.com>).
- 2 Double-click the **BROTHER** icon on your desktop.
- 3 Double-click **Brother Support**.
- 4 Click **Presto! PageManager** to download the Presto! PageManager installer.
- 5 Double-click the installer, and then follow the on-screen instructions.

#### NOTE

---

- Presto! PageManager supports OS X v10.7.5, 10.8.x and 10.9.x.
  - For more details about the application refer to the Presto! PageManager help file. You can access this from the Presto! PageManager Help menu.
- 

### Scan Using Presto! PageManager

---

- 1 Start Presto! PageManager by double-clicking the Presto! PageManager icon on your computer screen.

#### NOTE

---

The first time you use the Brother TWAIN driver, set it as the default driver:

- 1 Click **File > Select Source**.
  - 2 Select **Brother TWAIN**, then click **Select**.
-

- 2 Click **File > Acquire Image Data**.  
The scanner setup dialog box appears.

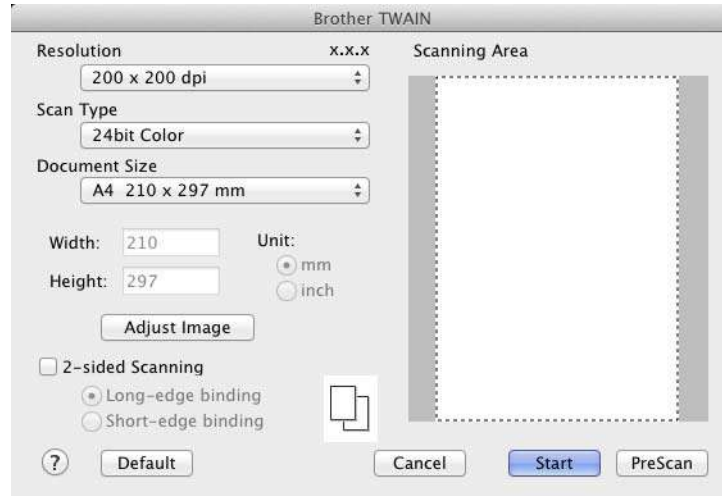

(The Brother TWAIN screen supports languages specified in Presto! PageManager.)

- 3 Adjust the settings in the scanner setup dialog box if needed.
- 4 From the **Document Size** pop-up menu, select your document size.

## NOTE

After you select a document size, you can adjust the scanning area further by clicking the left mouse button and dragging it. This is required when cropping an image for scanning.

- 5 Click the **Start** button.  
The machine starts scanning.

## TWAIN Driver Settings

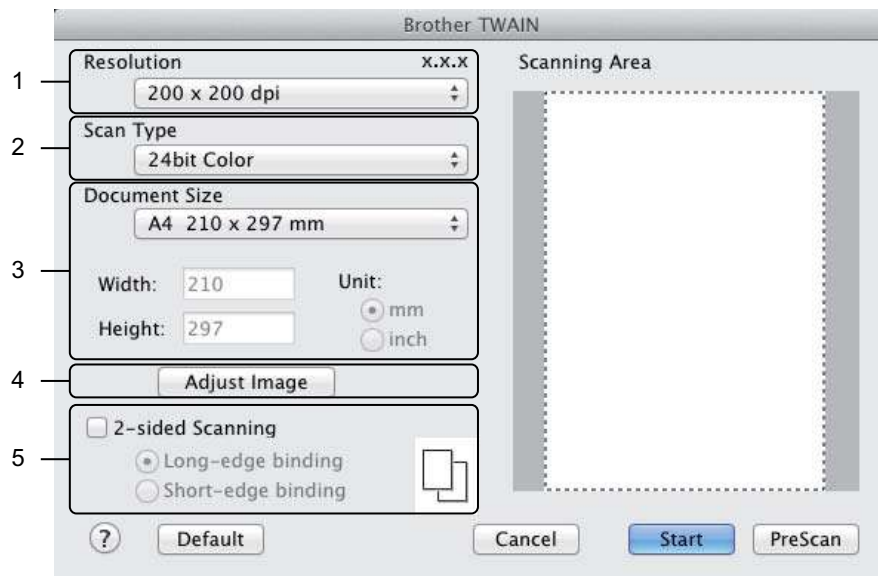

(The Brother TWAIN screen supports languages specified in Presto! PageManager.)

### 1 Resolution

Select a scanning resolution from the **Resolution** pop-up menu. Higher resolutions take more memory and transfer time, but produce a finer scanned image.

Resolution	Black & White/Gray (Error Diffusion)	256 Color	True Gray/24bit Color
100 x 100 dpi	Yes	Yes	Yes
150 x 150 dpi	Yes	Yes	Yes
200 x 200 dpi	Yes	Yes	Yes
300 x 300 dpi	Yes	Yes	Yes
400 x 400 dpi	Yes	Yes	Yes
600 x 600 dpi	Yes	Yes	Yes
1,200 x 1,200 dpi	Yes	No	Yes

### 2 Scan Type

Select one of the following:

#### ■ Black & White

Use for text or line art images.

#### ■ Gray (Error Diffusion)

Use for photographic images or graphics. (Error Diffusion is a method for creating simulated gray images without using true gray dots. Black dots are put in a specific pattern to give a gray appearance.)

### ■ True Gray

Use for photographic images or graphics. This mode is more exact due to using up to 256 shades of gray.

### ■ 256 Color

Use for simple color illustrations that do not use the full color spectrum. Uses up to 256 colors to create images.

### ■ 24bit Color

Uses up to 16.8 million colors to scan the image. Although using **24bit Color** creates an image with the most accurate color reproduction, it requires the most memory and has the longest transfer time.

## NOTE

**256 Color** is only available when your scanning application supports this setting. Presto! PageManager does not support **256 Color**.

## 3 Document Size

Document size is set to **Letter** by default. If you select **Custom**, you can specify the document size.

## 4 Adjust Image

Click the **Adjust Image** button for adjusting the image.

### ■ Brightness

Adjust the setting (-50 to 50) to get the best image. The default value of 0 represents an average and is usually suitable for most images. You can set the **Brightness** level by dragging the slider to the right or left to lighten or darken the image. You can also enter a value in the box to set the level. If the scanned image is too light, set a lower Brightness level and scan the document again. If the image is too dark, set a higher Brightness level and scan the document again.

## NOTE

The **Brightness** setting is only available when setting **Scan Type** to **Black & White**, **Gray (Error Diffusion)**, **True Gray** or **24bit Color**.

### ■ Contrast

Adjust the setting (-50 to 50) to get the best image. The default value of 0 represents an average and is usually suitable for most images. You can increase or decrease the contrast level by moving the slider to the right or left. An increase emphasizes dark and light areas of the image, while a decrease reveals more details in gray areas. You can also enter a value in the box to set the **Contrast**.

## NOTE



The **Contrast** setting is only available when setting **Scan Type** to **Gray (Error Diffusion)**, **True Gray** or **24bit Color**.

### ■ Reduce Noise

You can improve and enhance the quality of your scanned images with this selection. The Reduce Noise setting is available when using **24bit Color** and scan resolutions of 300 × 300 dpi, 400 × 400 dpi or 600 × 600 dpi.

### 5 2-sided Scanning

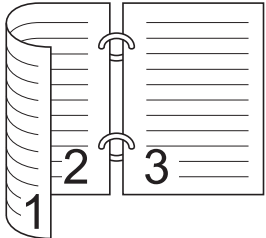
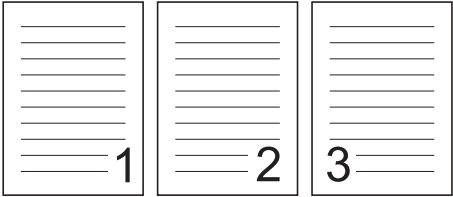
Select **Long-edge binding** or **Short-edge binding** depending on the layout of your original to make sure that the data file created appears correctly in the scanned document.

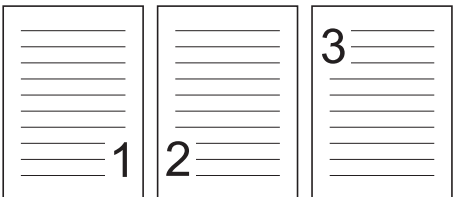
2-sided Scan Setting	Original Layout	Scan Result
<p><b>Long-edge binding</b></p>		
<p><b>Short-edge binding</b></p>		

## Scan Using Apple Image Capture (ICA Driver)

You can scan a document using the ICA driver. If you installed Full Driver & Software Package from the Brother Solutions Center (<http://support.brother.com>), the ICA driver has been already installed on your computer. If you don't see your machine in the **Print & Fax** or **Print & Scan** list, you can add your machine by clicking the + button (see *Select your machine from Print & Fax or Print & Scan* on page 117). You can also scan directly using the **Image Capture** application.

### Scan Using Apple Image Capture

- 1 Launch the **Image Capture** application.



- 2 Select the machine from the list on the left side of the window.  
You will see the machine in the **DEVICES** area. If connected via wireless or Ethernet LAN, you will see it in the **SHARED** area.

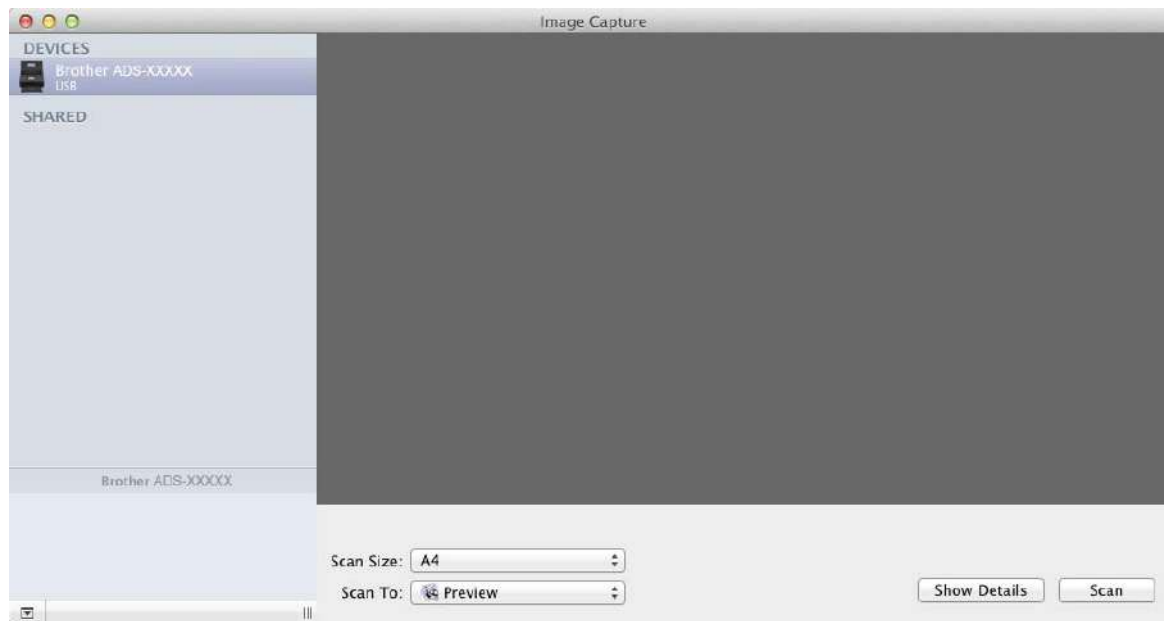

- 3 Load your document.
- 4 Select a size of your document for **Scan Size**.
- 5 Select the destination folder or destination application for **Scan To**.
- 6 Click the **Scan** button.  
The machine starts scanning.

## ICA Driver Settings

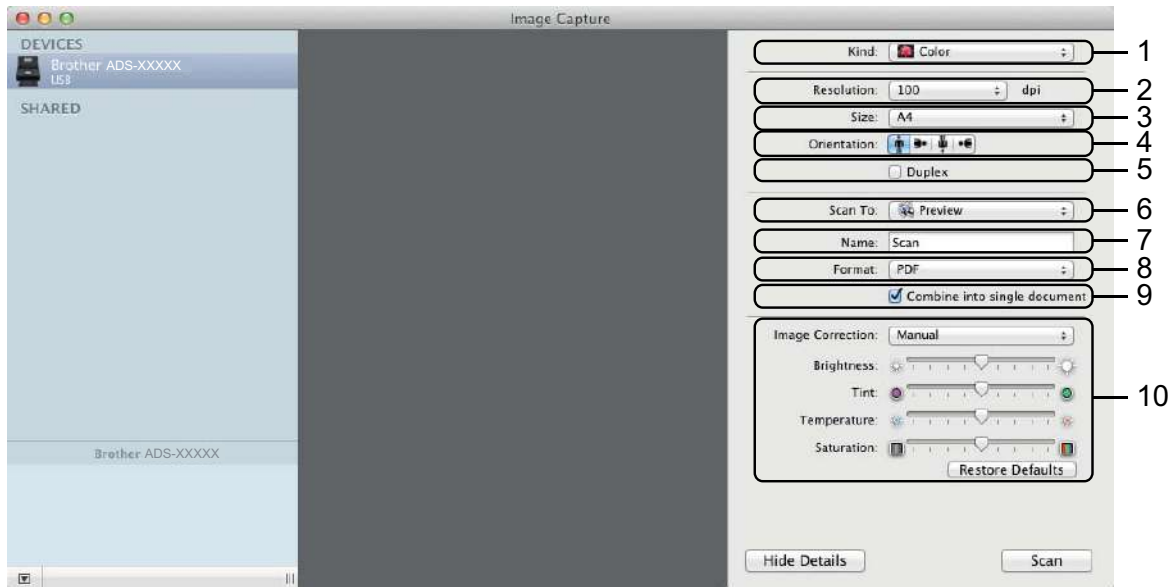

You can adjust the following settings, if needed, in the dialog box accessed by clicking on **Show Details**. Note that the item name and assignable value will vary depending on the machine.

### 1 Kind

Select from **Color**, **Black & White** or **Text**.

### 2 Resolution

Select the resolution you want to scan your document at.

### 3 Scan Size or Size

Select the paper size of the document.

### 4 Orientation

Select the orientation of the document.

### 5 Duplex

Select the **Duplex** check box to do 2-sided (duplex) scanning.

### 6 Scan To

Select the destination folder or destination application.

### 7 Name

Enter the prefix text used for the name of the scanned image.

### 8 Format

Select the file format of the scanned data.

## 9 Combine into single document

Check this box to scan a document as one item and save it as one file when selecting PDF or TIFF for the file format.

### NOTE

(OS X v10.7.5 only)

If you cannot select TIFF for the file format, select PDF first and then select TIFF.

## 10 Image Correction

You can configure settings depending on **Kind** that you have chosen.

Kind	Configurable Settings
Color	Brightness, Tint, Temperature, Saturation
Black & White	Brightness, Contrast
Text	Threshold

## Select your machine from Print & Fax or Print & Scan

- 1 Select **System Preferences** in the Dock.
- 2 Click the **Print & Fax** icon or the **Print & Scan** icon.
- 3 Select the machine from the list on the left side of the screen.

### NOTE

If you do not see the **Open Scanner** button on the window, remove your machine by clicking the - button from the **Print & Fax** or **Print & Scan** list and then add your machine by clicking the + button.

## Use NewSoft Presto! BizCard 6 (Macintosh)

Presto! BizCard lets you manage the information from scanned business cards, such as names, companies, mailing addresses, phone/fax numbers and email addresses, on your computer. Simply scan, or import your business cards and Presto! BizCard automatically saves the data and image for each card. Different viewing modes are available for easy searching, editing, creating, and sorting.

### Installing NewSoft Presto! BizCard 6

---

- 1 Download the full driver and software package from the Brother Solutions Center (<http://support.brother.com>).
- 2 Double-click the **BROTHER** icon on your desktop.
- 3 Double-click **Brother Support**.
- 4 Click **Presto! BizCard** to download the Presto! BizCard 6 installer.
- 5 Double-click the installer, and then follow the on-screen instructions.

For information about how to scan using Presto! BizCard 6, see the Presto! BizCard 6 user's guide by clicking on **Help** on the menu bar, then **Using Help**.

## Scan Using Captiva<sup>®</sup> QuickScan<sup>™</sup> Pro or ISIS<sup>®</sup> Applications (Windows<sup>®</sup>)

You can use the free trial version of Captiva<sup>®</sup> QuickScan<sup>™</sup> Pro or other applications, which support the ISIS<sup>®</sup> specifications, for scanning. Before scanning using the ISIS<sup>®</sup> applications, you must install the ISIS<sup>®</sup> scanner driver.

### NOTE

In order to use the ISIS<sup>®</sup> driver, the Brother scanner driver needs to be installed. If you have not installed the Brother scanner driver, you must do so before installing the ISIS<sup>®</sup> driver.

## Installing ISIS<sup>®</sup> Scanner and Captiva<sup>®</sup> QuickScan<sup>™</sup> Pro

5

- 1 Insert the supplied DVD-ROM into your DVD-ROM drive.
- 2 The DVD-ROM top menu appears automatically. Select your model name and then the desired language.
- 3 Click **Custom Installation**.
- 4 Click the **ISIS Scanner Driver & Application** button.
- 5 Click the **ISIS Scanner Driver** button. Follow the on-screen instructions.
- 6 Click the **Captiva QuickScan Pro Trial** button. Follow the on-screen instructions.

### NOTE

- The web site where you can download the free trial version of Captiva<sup>®</sup> QuickScan<sup>™</sup> Pro is operated by EMC Corporation. If you have any questions about Captiva<sup>®</sup> QuickScan<sup>™</sup> Pro, contact EMC Corporation (<http://www.emc.com>).
- For information about how to scan using your ISIS<sup>®</sup> application, see Captiva<sup>®</sup> QuickScan<sup>™</sup> Pro's Help menu.

# 6

## Scan Using the Control Panel

### Save Scanned Documents on Your Computer

(ADS-2000e)

- 1 Start the ControlCenter application.
  - Windows®
    - 1 Click the  (ControlCenter4) icon in the task tray and then select **Open** from the menu. The **ControlCenter4** window appears.
    - 2 Click the **Device Settings** tab (the example below uses **Home Mode**).

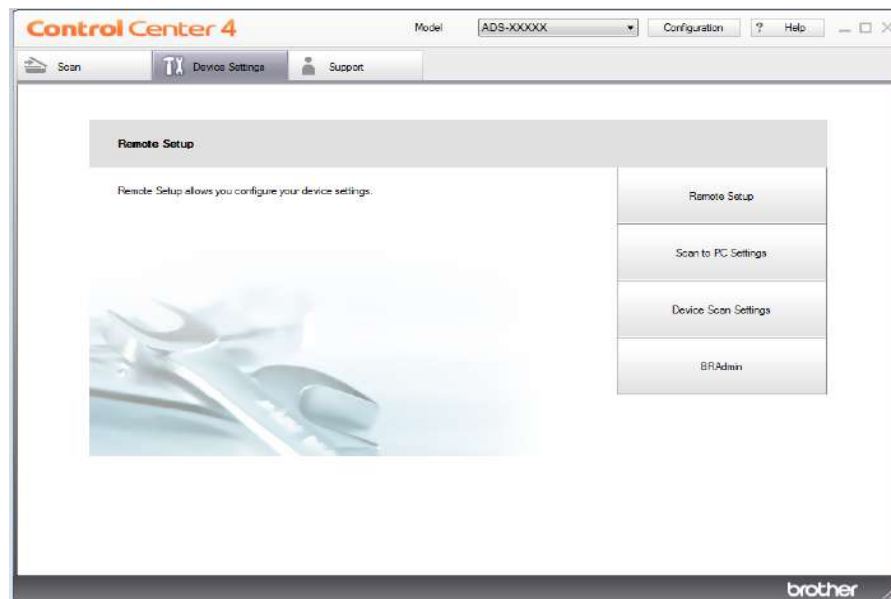

■ Macintosh

- 1 Click the  (ControlCenter2) icon in the Dock. The **ControlCenter2** window appears.
- 2 Click the **DEVICE SETTINGS** tab.



- 2 Click the **Scan to PC Settings** button. The Remote Setup window appears (the example below uses Windows®).

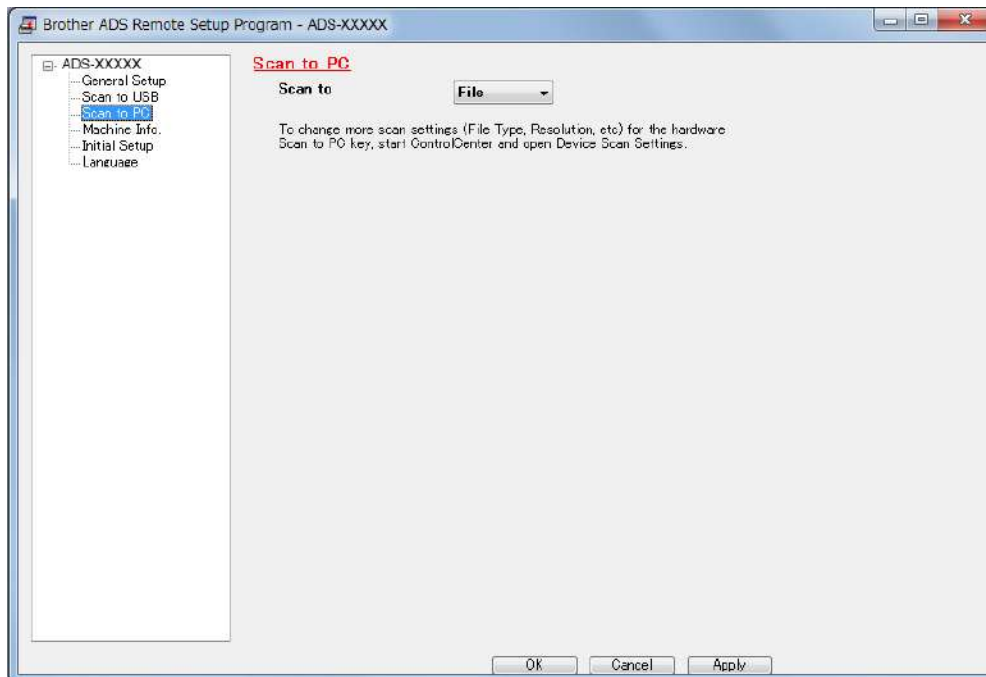

- 3 Select a Scan-to action you want to assign (**Image**, **OCR**, **E-mail**, or **File**) from the pop-up menu.
- 4 Click **OK** to close the Remote Setup window.
- 5 Change other settings if needed (see *Change Scan to PC Settings (Windows®)* on page 147 or *Change Scan to PC Settings (Macintosh)* on page 154).

- 6 Load your document.
- 7 Press **Scan to PC**. The machine scans the document.  
(ADS-2500We)
- 1 Load your document.
- 2 Swipe left or right, or press ◀ or ▶ to display `Scan 1`.
- 3 Press `to PC`.
- 4 Swipe left or right to display the Scan-to action you want to do (`to OCR`, `to File`, `to Image` or `to E-mail`).
- 5 Press the Scan-to action you want to do and then `OK`.
- 6 Press ▲ or ▼ to display the destination computer you want to save on.  
Press the destination computer.
- 7 Press `Start`.  
The machine starts the scanning process.

## NOTE

- You can configure the Scan-to settings from your computer. See *Change Scan to PC Settings (Windows®)* on page 147 or *Change Scan to PC Settings (Macintosh)* on page 154.
- If you want to save the settings as a shortcut, press `Save as Shortcut`. For more information, see *Scanner Shortcuts (ADS-2500We only)* on page 160.

## Save Scanned Documents on a USB Flash Drive

(ADS-2000e)

- 1 Start the ControlCenter application.
  - Windows®
- 1 Click the  (ControlCenter4) icon in the task tray and then select **Open** from the menu. The **ControlCenter4** window appears.
- 2 Click the **Device Settings** tab (the example below uses **Home Mode**).

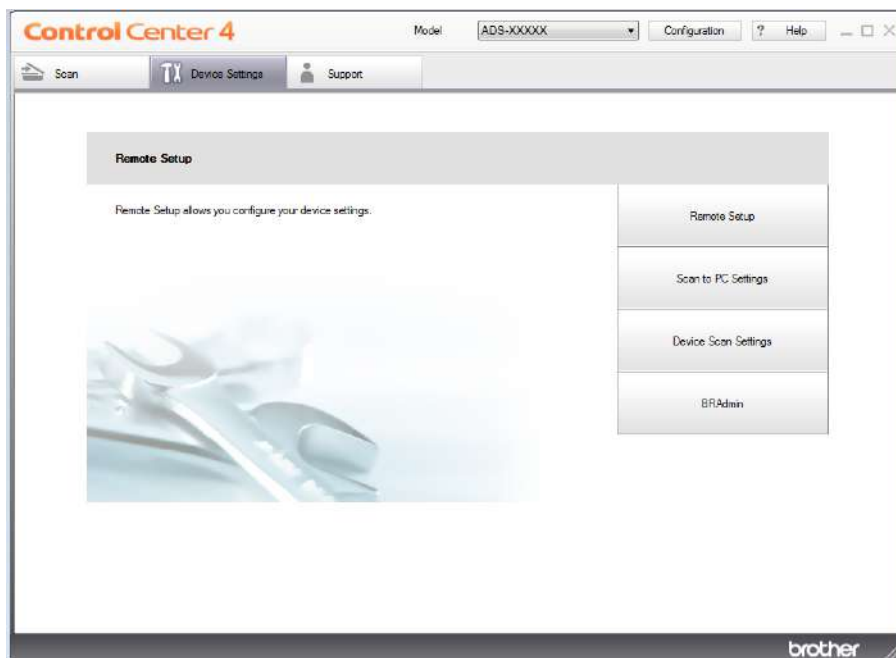

■ Macintosh

- 1 Click the  (ControlCenter2) icon in the Dock. The **ControlCenter2** window appears.
- 2 Click the **DEVICE SETTINGS** tab.



- 2 Click the **Remote Setup** button. The Remote Setup window appears.
- 3 Select **Scan to USB** in the folder tree and then configure scan settings as needed (the example below uses Windows®).

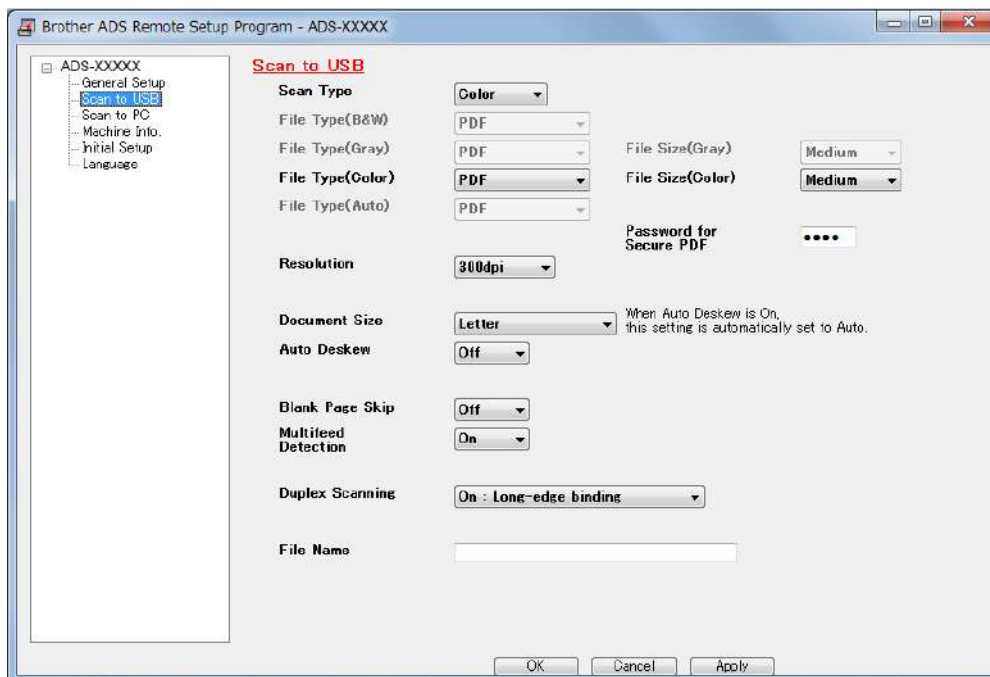

- 4 Click **Apply** and then **OK**.
- 5 Insert a USB flash drive into the machine.

- 6 Load your document.
- 7 Press **Scan to USB** on the control panel. The machine starts scanning.

---

**NOTE**

The file name will be the current date plus a two-digit sequential number.

---

(ADS-2500We)

- 1 Insert a USB flash drive into your machine.
- 2 Load your document.
- 3 Swipe left or right, or press ◀ or ▶ to display *Scan 2*.
- 4 Press *to USB*.
- 5 Press *Options*.
- 6 Configure the settings for 2-sided Scan, Scan Type, Resolution, File Type, Document Size, File Name, Auto Deskew and Skip Blank Page as needed. Press *OK*.

---

**NOTE**

- To select Long Paper (up to 34in) for Document Size, use these settings:
    - Auto Deskew: Off
    - 2-sided Scan: Off
  - If you want to save the settings as a new default, press *Set New Default*.
  - If you want to restore all settings to the factory settings, press *Factory Reset*.
- 

- 7 Press *Start*.  
The machine starts scanning, and then the scanned data is saved on the USB flash drive.

---

**NOTE**

If you want to save the settings as a shortcut, press *Save as Shortcut*. For more information, see *Scanner Shortcuts (ADS-2500We only)* on page 160.

---

---

**IMPORTANT**

DO NOT remove the USB flash drive while the machine is scanning to the USB flash drive to avoid damaging the drive or the data stored on it.

---

## Save Scanned Documents on Mobile Devices

---

The machine can save the scanned data on a mobile device.

### NOTE

---

- This feature can be used with mobile devices that use the USB mass storage standard.
  - The machine does not support charging any USB devices.
  - Brother Image Viewer for Android™, which is available for download from the Google Play (Android™ Market), enables users to view or edit the scanned data. For details, download the Brother Image Viewer for Android™.
- 

- 1 Connect the machine to a mobile device with a USB cable that came with your mobile device.

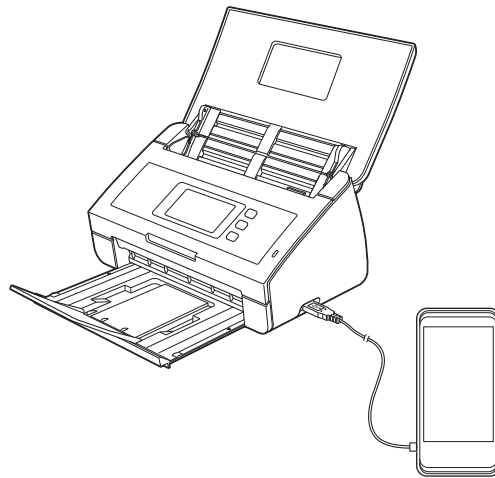

### NOTE

---

The mobile device must be turned on before connecting to the machine.

---

- 2 Load your document.
  - If your machine is ADS-2000e, go to 3.
  - If your machine is ADS-2500We, go to 4.
- 3 (ADS-2000e)  
Press the **Scan to USB** key. The machine starts scanning, and then the scanned data is saved on the mobile device.
- 4 (ADS-2500We)
  1. Swipe left or right, or press ◀ or ▶ to display **Scan 2**.
  2. Press **to USB**.
  3. Press **Options**.
  4. Select the settings for **2-sided Scan**, **Scan Type**, **Resolution**, **File Type**, **Document Size**, **File Name**, **File Size**, **Auto Deskew** and **Skip Blank Page** as needed.
  5. Press **OK**.

---

**NOTE**

- If you want to save the settings as a new default, press `Set New Default`.
  - If you want to restore all settings to the factory settings, press `Factory Reset`.
- 

6. Press `Start`.

The machine starts scanning, and then the scanned data is saved on the mobile device.

---

**NOTE**

If you want to save the settings as a shortcut, press `Save as Shortcut`. For more information, see *Scanner Shortcuts (ADS-2500We only)* on page 160.

---

## Scan Documents to an FTP Server (ADS-2500We only)

When you choose Scan to FTP, you can scan a black and white or color document directly to an FTP server on your local network, or on the Internet.

The details required to use Scan to FTP can be entered by using Web Based Management to pre-configure and store the details in an FTP Profile.

### NOTE

- Scan to FTP is available when FTP profiles are configured by using Web Based Management.
- We recommend Microsoft® Internet Explorer® 8.0/9.0 for Windows® and Safari 5.0 for Macintosh. Also make sure that JavaScript and Cookies are always enabled in whichever browser you use. If a different web browser is used, make sure it is compatible with HTTP 1.0 and HTTP 1.1.

## Start Web Based Management

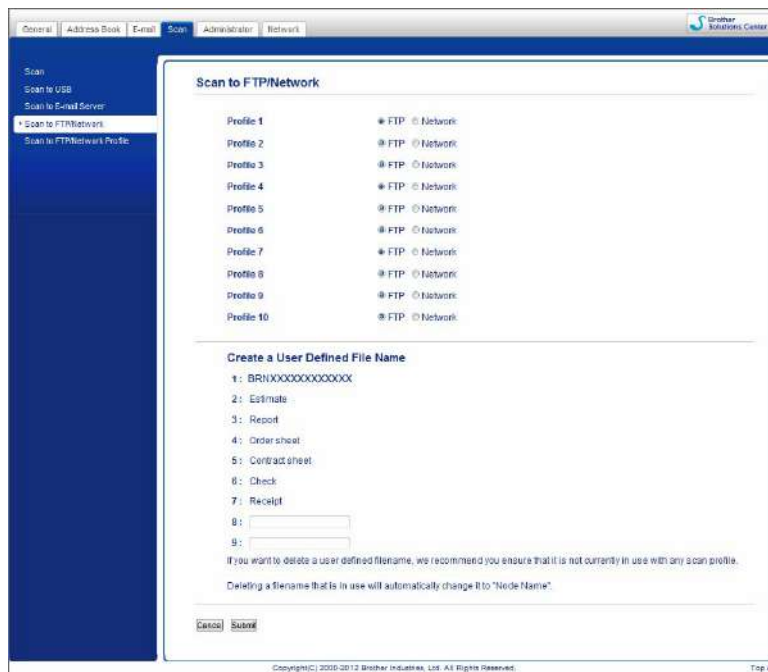

Type `http://xxx.xxx.xxx.xxx` (where `xxx.xxx.xxx.xxx` is the IP address of your machine) into your browser.

You can configure or change the settings in **Scan to FTP/Network** in the **Scan** tab. You can configure up to five FTP server profiles and choose what profile numbers (1 to 10) to use for Scan to FTP settings in **Scan to FTP/Network Profile**.

In addition to the seven preset file names you can store two user defined file names that can be used for creating an FTP Server Profile.

Choose **Scan to FTP/Network** in Web Based Management. In **Create a User Defined File Name**, enter a file name in one of the two user defined fields and click **Submit**. A maximum of 15 characters can be entered in each of the user defined name fields.

**NOTE**

---

Do not use unsuitable characters in the file name (for example ?, /, \, or \*). They may cause a sending error when using Scan to FTP.

---

## Configure the FTP Default Settings

You can set **Passive Mode** to **Off** or **On** depending on your FTP server and network firewall configuration. By default this setting is **On**. You can also change the port number used to access the FTP server. The default for this setting is port 21. In most cases these two settings can remain as the default.

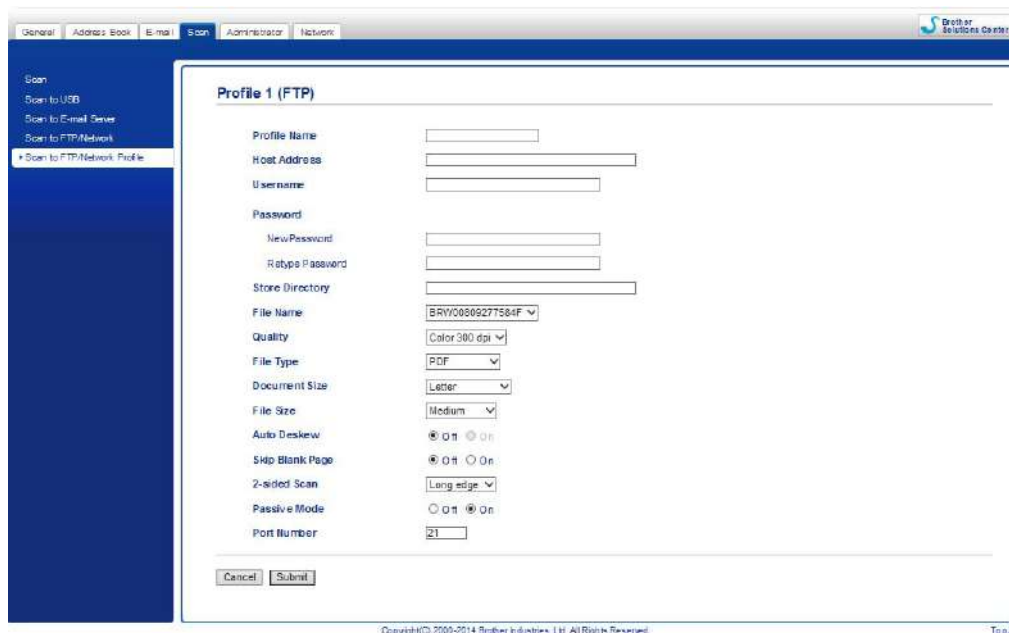

- 1 Enter the name that you want to use for the profile of the FTP server. This name will be displayed on the LCD of the machine, and can be up to 15 characters.
- 2 The Host Address is the domain name of the FTP server. Enter the Host Address (for example ftp.example.com) (up to 64 characters) or the IP address (for example 192.23.56.189).
- 3 Enter the Username that has been registered with the FTP server for the machine (up to 32 characters).
- 4 Enter the Password for access to the FTP server (up to 32 characters).
- 5 Enter the destination folder where your document will be stored on the FTP server (for example brother\abc) (up to 60 characters).
- 6 Choose the file name you want to use for the scanned document. You can choose from seven preset and two user defined file names. The file name that will be used for your document will be the file name you selected plus the last 6 digits of the scanner counter plus the file extension (for example, Estimate\_098765.pdf).

- 7 Choose the quality, file type, document size and 2-sided Scan you want to use for the scanned data. The following settings can be changed.

Setting	Options	Description
<b>Quality</b>	<b>Color 150 dpi</b> <b>Color 200 dpi</b> <b>Color 300 dpi</b> <b>Color 600 dpi</b> <b>Gray 150 dpi</b> <b>Gray 200 dpi</b> <b>Gray 300 dpi</b> <b>Gray 600 dpi</b> <b>B&amp;W 150 dpi</b> <b>B&amp;W 200 dpi</b> <b>B&amp;W 300 dpi</b> <b>B&amp;W 600 dpi</b> <b>Auto 150 dpi</b> <b>Auto 200 dpi</b> <b>Auto 300 dpi</b> <b>User Select</b>	<ul style="list-style-type: none"> <li>■ You can select a scanning quality from the <b>Quality</b> drop-down list. Higher qualities take more memory and transfer time, but produce a finer scanned image.</li> <li>■ If you select <b>User Select</b>, you must select the setting from the control panel of the machine.</li> </ul>
<b>File Type</b>	<b>PDF</b> <b>Secure PDF</b> <b>PDF/A</b> <b>Signed PDF</b> <b>TIFF</b> <b>JPEG</b> <b>XPS</b> <b>User Select</b>	<ul style="list-style-type: none"> <li>■ You can select the file type you want to use for the scanned data.</li> <li>■ If you select <b>Secure PDF</b>, the machine will ask you to enter a 4 digit password using numbers 0-9 before it starts scanning.</li> <li>■ If you select <b>Signed PDF</b>, you must install a certificate to your machine using Web Based Management. Select <b>Signed PDF</b> from <b>Administrator</b> in Web Based Management. See the Network User's Guide.</li> <li>■ PDF/A is a PDF file format intended for long-term archiving. This format contains all the necessary information to be able to reproduce the document after long-term storage.</li> <li>■ Signed PDF helps prevent data tampering and the impersonation of an author by including a digital certificate within the document.</li> <li>■ You can select <b>PDF</b>, <b>Secure PDF</b>, <b>PDF/A</b>, <b>Signed PDF</b>, <b>JPEG</b> or <b>XPS</b> when you select <b>Color</b> or <b>Gray</b> in <b>Quality</b>.</li> <li>■ You can select <b>PDF</b>, <b>Secure PDF</b>, <b>PDF/A</b>, <b>Signed PDF</b> or <b>TIFF</b> when you select <b>B&amp;W</b> in <b>Quality</b>.</li> <li>■ You can select <b>PDF</b>, <b>Secure PDF</b> or <b>Signed PDF</b> when you select <b>Auto</b> in <b>Quality</b>.</li> <li>■ If you select <b>User Select</b>, you must select the setting from the control panel of the machine.</li> </ul>

Setting	Options	Description
<b>Document Size</b>	<b>Auto</b> <b>A4</b> <b>Letter</b> <b>Legal</b> <b>B5</b> <b>A5</b> <b>B6</b> <b>A6</b> <b>Business Card</b> <b>Long Paper</b>	<ul style="list-style-type: none"> <li>■ If you select <b>Auto</b>, you can scan documents of any size without making any adjustments to <b>Document Size</b>. For faster scan speeds, you can select the exact size of your document from the <b>Document Size</b> drop-down list.</li> <li>■ If you select <b>600 dpi</b> for <b>Quality</b>, you cannot select <b>Auto</b>.</li> <li>■ <b>Long Paper</b> in the <b>Document Size</b> drop-down list appears when you select other than <b>Auto XXX dpi</b> (XXX is a value of the quality) for <b>Quality</b> and <b>Auto Deskew</b> is set to Off.</li> <li>■ You can select <b>A4, Letter, Legal, B5, A5, B6, A6, Business Card</b> or <b>Long Paper</b> (when you select other than <b>Auto XXX dpi</b> for <b>Quality</b>) when <b>Auto Deskew</b> is set to Off.</li> <li>■ You can select <b>Long Paper</b> when you configure the settings as following: <ul style="list-style-type: none"> <li>• <b>Quality</b>: other than <b>Auto</b></li> <li>• <b>Auto Deskew</b>: Off</li> <li>• <b>Skip Blank Page</b>: Off</li> <li>• <b>2-sided Scan</b>: Off</li> </ul> </li> </ul>
<b>File Size</b>	<b>Small</b> <b>Medium</b> <b>Large</b> <b>User Select</b>	<ul style="list-style-type: none"> <li>■ You can adjust the file size for the scanned data.</li> <li>■ If you select <b>Color</b> or <b>Gray</b> in <b>Quality</b>, select the file size for the scanned data from the drop-down list.</li> <li>■ If you select <b>User Select</b>, you must select the setting from the control panel of the machine.</li> </ul>
<b>2-sided Scan</b>	<b>Off</b> <b>Long edge</b> <b>Short edge</b>	To scan both sides of the document, select <b>Long edge</b> or <b>Short edge</b> depending on the layout of your original to make sure that the data file created appears correctly in the scanned document.

- 8 Set **Auto Deskew**<sup>1</sup> to **On** if you want to correct the skew (within 5 degrees) of the scanned data.
- 9 Set **Skip Blank Page**<sup>1</sup> to **On** if you want to remove blank pages of the document from the scanned data.
- 10 Click **Submit**.

<sup>1</sup> Depending upon the condition of the original document, this function may not work properly.

## Scan Using FTP Server Profiles

---

- 1 Load your document.
- 2 Press ◀ or ▶ to display to FTP.
- 3 Press to FTP.
- 4 Press ▲ or ▼ to choose one of the FTP server profiles listed.  
Do one of the following:
  - If the Scan to FTP profile is complete, go to 7
  - If the Scan to FTP profile is not complete, go to 5.
- 5 Press Options.
- 6 Choose the settings for 2-sided Scan, Scan Type, Resolution, File Type, Document Size, File Size, Auto Deskew, Skip Blank Page and User Name as needed. Press OK.

### NOTE

---

If you want to save the profile as a shortcut, press Save as Shortcut.

---

- 7 Press Start.  
The LCD displays Connecting. When the connection to the FTP server is successful the machine starts the scanning process.

## Scan Documents to a Shared Folder / Network Location (Windows®) (ADS-2500We only)

When you choose Scan to Network, you can scan documents directly to a shared folder located on your local network or the Internet.

The details required to use Scan to Network can be entered by using Web Based Management to preconfigure and store the details in a Scan to Network profile. The Scan to Network profile stores user information and configuration settings for use on a network, or the Internet.

### NOTE

---

- Scan to Network is available when Scan to Network profiles are configured by using Web Based Management.
  - YOU MUST CONFIGURE THE SNTP PROTOCOL (NETWORK TIME SERVER), OR YOU MUST SET THE DATE, TIME AND TIME ZONE CORRECTLY FOR AUTHENTICATION. FOR MORE INFORMATION, SEE THE Network User's Guide.
  - We recommend Microsoft® Internet Explorer® 8.0/9.0. Also make sure that JavaScript and Cookies are always enabled in whichever browser you use. If a different web browser is used, make sure it is compatible with HTTP 1.0 and HTTP 1.1.
- 

Type `http://xxx.xxx.xxx.xxx` (where `xxx.xxx.xxx.xxx` is the IP address of your machine) into your browser. You can configure or change the settings in **Scan to FTP/Network** in the **Scan** tab. You can configure up to five Scan to Network profiles and choose what profile numbers (1 to 10) to use for Scan to Network settings in **Scan to FTP/Network Profile**.

In addition to the seven preset file names you can store two user defined file names that can be used for creating a Scan to Network profile.

Choose **Scan to FTP/Network** in Web Based Management. In **Create a User Defined File Name**, enter a file name in one of the two user defined fields and click **Submit**. A maximum of 15 characters can be entered in each of the user defined name fields.

## NOTE

Do not use unsuitable characters in the file name (for example ?, /, \, or \*). They may cause a sending error when using Scan to Network.

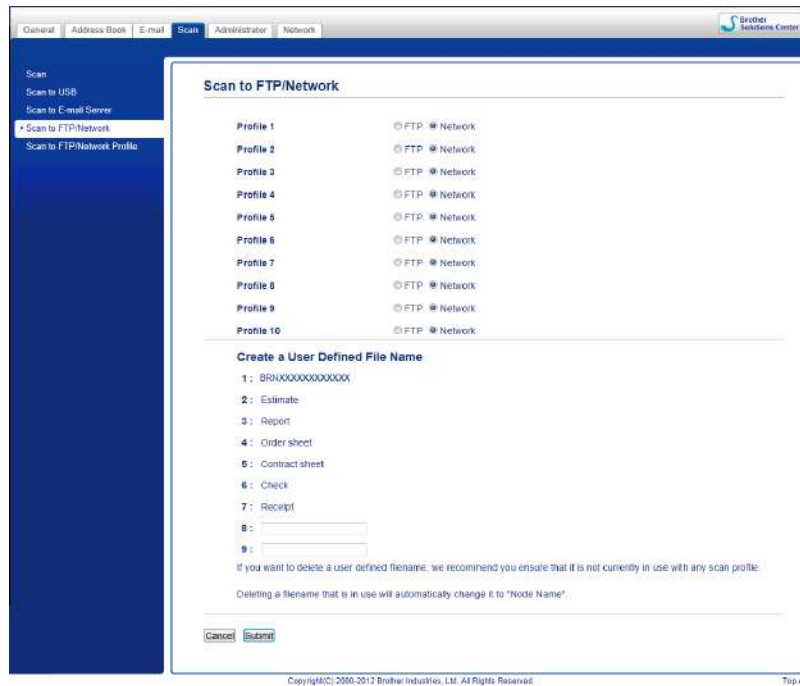

## Configure the Scan to Network Default Settings

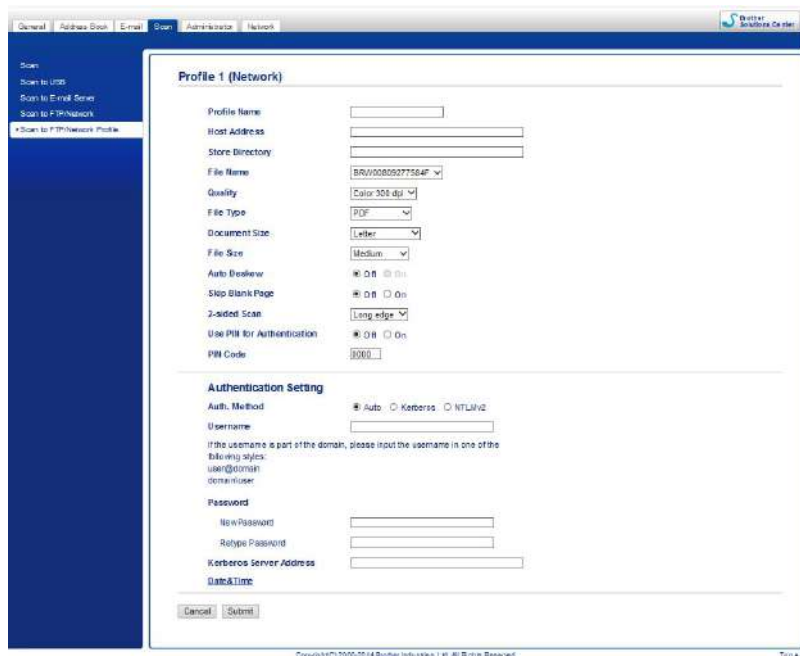

- 1 Choose **Network** in **Scan to FTP/Network** from the **Scan** tab. Click **Submit**.
- 2 Choose the Profile you want to configure in **Scan to FTP/Network Profile**.
- 3 Enter the name that you want to use for the Scan to Network profile. This name will be displayed on the LCD of the machine and can be up to 15 characters.
- 4 The Host Address is the domain name of the CIFS server. Enter the Host Address (for example mypc.example.com) (up to 64 characters) or the IP address (for example 192.23.56.189).
- 5 Enter the destination folder where your document will be stored on the CIFS server (for example brother\abc) (up to 60 characters).
- 6 Follow the steps from **8** to **9** of *Configure the FTP Default Settings* on page 130.
- 7 If you want to protect the profile, choose **On** from **Use PIN for Authentication** and enter a 4-digit PIN number in **PIN Code**.
- 8 Choose the authentication method. You can choose **Auto**, **Kerberos** or **NTLMv2**. If you choose **Auto**, the authentication method will be detected automatically.
- 9 Enter the **Username** that has been registered with the CIFS server for the machine (up to 96 characters).
- 10 Enter the **Password** for access to the CIFS server (up to 32 characters).
- 11 Click **Submit**.
- 12 Choose **Date&Time** from the **General** tab.
- 13 Enter the date and time used on the CIFS server.
- 14 Choose the time zone from the pull-down list.
- 15 Click **Submit**.

## Scan Using Scan to Network Profiles

---

- 1 Load your document.
- 2 Swipe left or right, or press ◀ or ▶ to display Scan 1.
- 3 Press to Network.
- 4 Press ▲ or ▼ to choose one of Network server profiles listed.  
If the LCD prompts you to enter a PIN number, enter the 4-digit PIN number for the profile on the LCD.  
Press OK.  
Do one of the following:
  - If the Scan to Network profile is complete, go to 7.
  - If the Scan to Network profile is not complete, go to 5.
- 5 Press Options.
- 6 Choose the settings for 2-sided Scan, Scan Type, Resolution, File Type, Document Size, File Size, Auto Deskew, Skip Blank Page and User Name as needed. Press OK.

### NOTE

---

- If you choose Secure PDF for File Type, the machine will ask you to enter a 4 digit password using numbers 0-9 before it starts scanning.
  - If you choose Signed PDF for File Type, you must install and then configure a certificate to your machine using Web Based Management.
  - If you want to save the settings as a shortcut, press Save as Shortcut.
- 
- 7 Press Start.  
The LCD displays Connecting. When the connection to the Network is successful the machine starts the scanning process.

## Scan Using Web Services (Windows Vista® SP2 or Later, Windows® 7, Windows® 8 and Windows® 8.1) (ADS-2500We)

The menu that allows you to use Web Services for scanning is displayed on the LCD of the machine, if you have installed the driver for scanning via Web Services. For information about installing Web Services, see *Install Drivers Used for Scanning via Web Services (Windows Vista®, Windows® 7, Windows® 8, Windows® 8.1)* in the *Network User's Guide*.



### NOTE

- If the LCD or LED indications show Out of Memory, decrease the **Paper size** setting or the **Resolution** setting. For more information, see *Configuring Settings for Scanning* on page 138.
- Certain characters in the messages displayed on the LCD may be replaced with spaces when the language settings of your OS and your Brother machine are different.

- 1 Load your document.
- 2 Swipe left or right, or press ◀ or ▶ to display Scan 1.
- 3 Press to PC.
- 4 Press ◀ or ▶ to display WS Scan.
- 5 Press WS Scan and then OK.
- 6 Press the type of scan you want to do.
- 7 Press ▲ or ▼ to display the destination computer you want to send to.  
Press the destination computer.
- 8 Press Start.  
The machine starts scanning process.

### Configuring Settings for Scanning

If the LCD or LED indications show Out of Memory, decrease the **Paper size** setting or the **Resolution** setting.

- 1 (Windows Vista®)
  -  (Start) > **Control Panel** > **Hardware and Sound** > **Scanners and Cameras**.
 (Windows® 7)
  -  (Start) > **Control Panel** > **Hardware and Sound** > **Devices and Printers**.
 (Windows® 8 and Windows® 8.1)
 

Move your mouse to the lower right corner of your desktop. When the menu bar appears, click **Settings**, and then click **Control Panel**. In the **Hardware and Sound** group, click **View devices and printers**.
- 2 Click your machine, and then click the **Scan profiles** button.  
The **Scan profiles** dialog box appears.

- 3 Choose the scan profile you want to use. Make sure the scanner selected in **Scanner** is a Brother machine that supports Web Services for scanning.  
Click **Set as Default**.
- 4 Click **Edit**. The **Edit Default Profile** dialog box appears.
- 5 Choose the **Source**, **Paper size**, **Color format**, **File type**, **Resolution**, **Brightness** and **Contrast** settings.
- 6 Click **Save Profile**. The settings will be applied when scanning using the Web Services protocol.

---

**NOTE**

If you are requested to choose a software application to scan, choose Windows<sup>®</sup> Fax and Scan or Windows<sup>®</sup> Photo Gallery from the list.

---

## Send Scanned Documents Directly to an Email Address (ADS-2500We only)

- 1 Load your document.
- 2 Swipe left or right, or press ◀ or ▶ to display `Scan 2`.
- 3 Press `to E-mail Server`.
- 4 Select the email address you want to send to by doing one of the following:
  - If you want to select an email address from the Address Book, see *Select an email Address from the Address Book* on page 140.
  - If you want to enter an email address manually, see *Enter an email Address Manually* on page 141.

### NOTE

You can select up to 300 email addresses from the Address Book and enter up to 50 email addresses manually. The scanned data will be sent to all of the addresses at the same time.

- 5 Press `OK` and then do one of the following:
  - If you want to use the default settings, go to 8.
  - If you want to change the default settings, go to 6.
- 6 Press `Options`.
- 7 Select the settings for `2-sided Scan`, `Scan Type`, `Resolution`, `File Type`, `Document Size`, `Auto Deskew` and `Skip Blank Page` as needed. Press `OK`.

### NOTE

- If you want to save the settings as a new default, press `Set New Default`.
- If you want to restore all settings to the factory settings, press `Factory Reset`.

- 8 Press `Start`.  
The machine starts scanning and then sends the scanned document to the email address directly.

### NOTE

If you want to save the settings as a shortcut, press `Save as Shortcut`. For more information, see *Scanner Shortcuts (ADS-2500We only)* on page 160.

## Select an email Address from the Address Book

- 1 Swipe left or right, or press ◀ or ▶ to display `Scan 2`.
- 2 Press `to E-mail Server`.
- 3 Press `Address Book`.

- 4 Press . The software keyboard appears on the LCD.

#### NOTE

---

- The LDAP protocol supports you to search for email addresses on your server. For information on how to configure LDAP protocol, see *Changing LDAP Configuration* in the Network User's Guide.
  - The LDAP search result will be shown on the LCD with  before the local address book search result.
- 

- 5 Enter the initial characters for your search and then press **OK**. The machine starts searching the Address Book, and then the search result will be shown.
- 6 Swipe left or right, or press **▲** or **▼** until you find the name you are looking for.
- 7 Press the name from the result.
- 8 Press **Apply**.

#### NOTE

---

- If you want to register an email address in the Address Book, see *Set Up the Address Book (ADS-2500We only)* on page 142.
  - You can select up to 300 email addresses from the Address Book and enter up to 50 email addresses manually. The scanned data will be sent to all of the addresses at the same time.
- 

## Enter an email Address Manually

---

- 1 Swipe left or right, or press **◀** or **▶** to display **Scan 2**.
- 2 Press **to E-mail Server**.
- 3 Press **Manual**. The software keyboard appears on the LCD.
- 4 Enter an email address and then press **OK**.
- 5 Press **OK**.

#### NOTE

---

You can enter up to 50 email addresses manually. The scanned data will be sent to all of the addresses at the same time.

---

## Set Up the Address Book (ADS-2500We only)

The Address Book feature lets you select an email address to send the scanned data directly. You can configure the Address Book from the control panel of the machine.

### NOTE

You can also configure the Address Book with Remote Setup.

## Register an email Address

You can register up to 300 email addresses and enter a name for each address.

- 1 Swipe left or right, or press ◀ or ▶ to display Scan 2.
- 2 Press to E-mail Server.
- 3 Press Address Book.
- 4 Press Edit.
- 5 Press Add New Address.
- 6 Press Name.
- 7 Enter a name and then press OK.
- 8 Press Address.
- 9 Enter an email address and then press OK.
- 10 Press OK.

## Change an email Address

- 1 Swipe left or right, or press ◀ or ▶ to display Scan 2.
- 2 Press to E-mail Server.
- 3 Press Address Book.
- 4 Press Edit.
- 5 Press Change.
- 6 Press ▲ or ▼ until you find the email address you want to change.
- 7 Press the email Address. If the email address is used in one or more shortcuts, the LCD displays that the address in the shortcut(s) will also change.
- 8 Press OK.

- 9 Do one of the following:
  - If you want to change the name, go to step 10.
  - If you want to change the email address, go to step 12.
- 10 Press **Name**. The software keyboard appears on the LCD.
- 11 Enter a new name and then press **OK**. Go to step 14.
- 12 Press **Address**. The software keyboard appears on the LCD.
- 13 Enter a new email address and then press **OK**.
- 14 Press **OK**.

## NOTE

The LCD displays a list of shortcuts using the email address you changed. The shortcut settings will automatically change.

## Delete an email Address

- 1 Swipe left or right, or press ◀ or ▶ to display **Scan 2**.
- 2 Press **to E-mail Server**.
- 3 Press **Address Book**.
- 4 Press **Edit**.
- 5 Press **Delete**.
- 6 Press ▲ or ▼ until you find the email address you want to delete.
- 7 Press the email address.  
Press **OK**.
- 8 Press **Yes**.

## NOTE

You cannot delete an email address used in a shortcut. Delete the shortcut first (see *Edit, Rename or Delete a Shortcut* on page 161).

## Set Up a Group

---

You can register up to 20 groups. Each group can have up to 15 email addresses.

### NOTE

---

Before setting up a group, you need to register more than one email address.

---

- 1 Swipe left or right, or press ◀ or ▶ to display `Scan 2`.
- 2 Press `E-mail Server`.
- 3 Press `Address Book`.
- 4 Press `Edit`.
- 5 Press `Setup Groups`.
- 6 Press `Name`.
- 7 Enter a group name and then press `OK`.
- 8 Press `Add/Delete`.
- 9 Press ▲ or ▼ until you find the email address you want to add to the group.
- 10 Press the email address and then `OK`.
- 11 Press `OK`.

## Change a Group

---

You can rename a group, add an email address to the group and delete an email address from the group.

- 1 Swipe left or right, or press ◀ or ▶ to display `Scan 2`.
- 2 Press `E-mail Server`.
- 3 Press `Address Book`.
- 4 Press `Edit`.
- 5 Press `Change`.
- 6 Press ▲ or ▼ until you find the group you want to change.
- 7 Press the group name.
- 8 Do one of the following:
  - If you want to rename the group, go to step 9.
  - If you want to add an email address to the group, go to step 11.
  - If you want to delete an email address from the group, go to step 11.

- 9 Press **Name**. The software keyboard appears on the LCD.
- 10 Enter a new group name. Go to step 14.
- 11 Press **Add/Delete**.
- 12 Press **▲** or **▼** until you find the email address you want to add or delete.
- 13 Press the email address.
- 14 Press **OK**.

## Delete a Group

---

- 1 Swipe left or right, or press **◀** or **▶** to display **Scan 2**.
- 2 Press **to E-mail Server**.
- 3 Press **Address Book**.
- 4 Press **Edit**.
- 5 Press **Delete**.
- 6 Press **▲** or **▼** until you find the group name you want to delete.
- 7 Press the group name, and then **OK**.
- 8 Press **Yes**.

## **Upload Scanned Documents to the Web (ADS-2500We only)**

Scan to Web lets you scan a document and upload it directly to Web Services. See the Web Connect Guide.

## Change Scan to PC Settings (Windows®)

- 1 Click the  (ControlCenter4) icon in the task tray and then select **Open** from the menu. The **ControlCenter4** window appears.

### NOTE

- The screens in this guide are from Windows® 7. Screens on your computer may vary depending on your operating system.
- If the  icon is not displayed in the task tray,

click  (**Brother Utilities**) on your desktop, and then click the drop-down list and select your model name (if not already selected). Click **SCAN** in the left navigation bar, and then click **ControlCenter4**.

- 2 Click the **Device Settings** tab (the example below uses **Home Mode**).

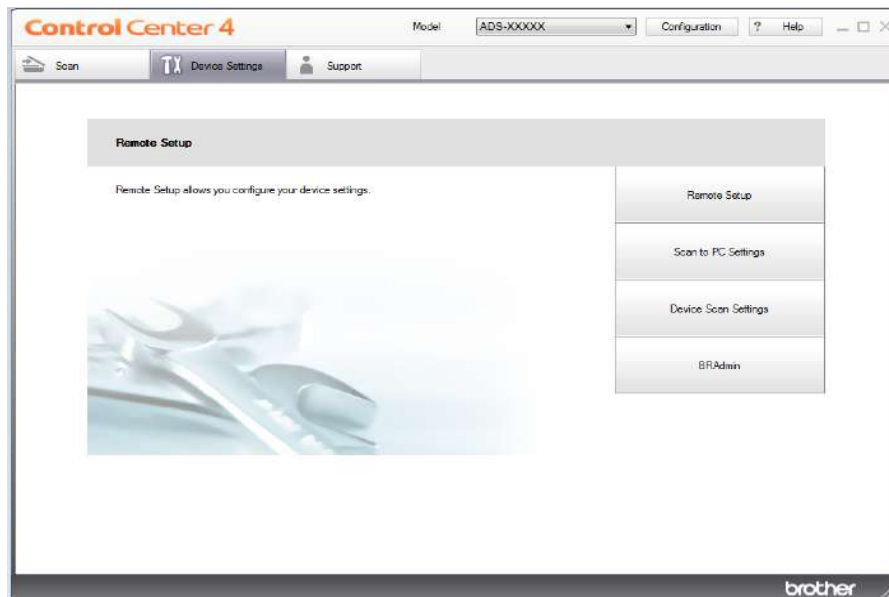

- 3 Click the **Device Scan Settings** button. The **Device Scan Settings** dialog box appears.

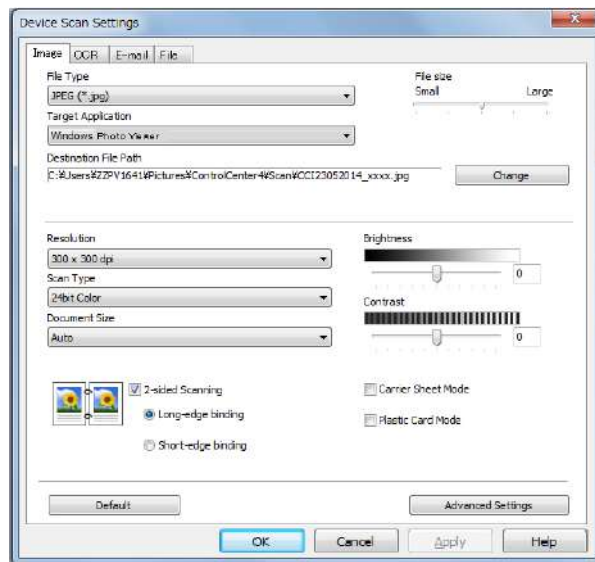

- 4 Click the tab for the Scan-to action you want to change (**Image**, **OCR**, **E-mail**, or **File**).
- 5 Change the settings.  
The following settings can be changed.

Setting	Description	Applicable Feature			
		Image	OCR	E-mail	File
<b>File Type</b>	<p>Select the file type you want to use for the scanned data.</p> <p><b>NOTE</b></p> <ul style="list-style-type: none"> <li>To save the document as a password-protected PDF, select <b>Secure PDF (*.pdf)</b> from the <b>File Type</b> drop-down list, click the  (<b>Set PDF Password</b>) button, and enter the password.</li> <li>Searchable PDF is a file format that includes the text data layer over a scanned image. This layer allows you to search the text on the image data. The OCR language setting must be set to match the language you want to make the searchable PDF for.</li> <li>To save the document as a searchable PDF, select <b>Searchable PDF (*.pdf)</b> from the <b>File Type</b> drop-down list.</li> <li>To save the document as a searchable PDF, Nuance™ PaperPort™ 12SE must be installed on your computer.</li> <li>Several file types such as TIFF, TIFF Multi-Page, PDF, Secure PDF and JPEG support file size compression. Select <b>Uncompressed</b> or <b>Compressed</b> to adjust the file size for TIFF or TIFF Multi-Page. For PDF, Secure PDF and JPEG, use the slider to adjust the file size (not available for Scan to OCR).</li> </ul>	Yes	Yes	Yes	Yes
<b>Target Application</b>	Select the destination application from the drop-down list.	Yes	Yes	-	-
<b>OCR Language</b>	Set to match the language of the scanned document's text.	-	Yes	-	-
<b>File Name</b>	<p>Click the <b>Change</b> button for <b>Image</b>, <b>OCR</b> or <b>E-mail</b>. Enter a prefix for the file name if needed.</p> <p>Click <b>Insert Date in File Name</b> if needed.</p>	Yes	Yes	Yes	Yes
<b>Destination File Path</b>	Click the <b>Change</b> button and then the folder icon to change the folder you would like to save your scanned document to.	Yes	Yes	Yes	-
<b>Destination Folder</b>	Click the folder icon and browse to the folder you would like to save your scanned document to. Check <b>Show Folder</b> to automatically display the destination folder after scanning.	-	-	-	Yes
<b>File size</b>	<p>Adjust the <b>File size</b> by moving the slider to the right or left.</p> <p><b>NOTE</b></p> <p><b>File size</b> can be adjusted depending on your selected <b>File Type</b>.</p>	Yes	-	Yes	Yes

Setting	Description	Applicable Feature			
		Image	OCR	E-mail	File
<b>Resolution</b>	Select a scanning resolution from the <b>Resolution</b> drop-down list. Higher resolutions take more memory and transfer time, but produce a finer scanned image.	Yes	Yes	Yes	Yes
<b>Scan Type</b>	<p>Select from a range of scan color depth.</p> <p><b>Black &amp; White</b> Use for text or line art images.</p> <p><b>Gray (Error Diffusion)</b> Use for photographic images or graphics. (Error Diffusion is a method for creating simulated grey images without using true grey dots. Black dots are put in a specific pattern to give a grey appearance.)</p> <p><b>True Gray</b> Use for photographic images or graphics. This mode is more exact due to using up to 256 shades of grey.</p> <p><b>24bit Color</b> Uses up to 16.8 million colors to scan the image. Although using <b>24bit Color</b> creates an image with the most accurate color reproduction, it requires the most memory and has the longest transfer time.</p> <p><b>Auto</b> Uses suitable colors for your document automatically.</p>	Yes	Yes	Yes	Yes
<b>Document Size</b>	<p>Document size is set to <b>Auto</b> by default. You can scan documents of any size without making any adjustments to <b>Document Size</b>. For faster scan speeds, you can select the exact size of your document from the <b>Document Size</b> drop-down list.</p> <p><b>NOTE</b></p> <ul style="list-style-type: none"> <li>• If you select a 1 to 2 document size, the scanned image will be divided into two documents that are half the size of the setting. If you select <b>1 to 2 (A4)</b>, the scanned image will be divided into two A5-size documents.</li> <li>• To do 1 to 2 scanning, unselect the <b>Auto Image Rotation</b> check box in the <b>Advanced Settings</b> dialog box.</li> <li>• If you select a 2 in 1 document size, two scanned images will be combined into one document.</li> <li>• You can select <b>Long Paper</b> when you configure the settings as following: <ul style="list-style-type: none"> <li>• <b>Auto Deskew:</b> Off</li> <li>• <b>2-sided Scanning:</b> Off</li> </ul> </li> </ul>	Yes	Yes	Yes	Yes

Setting	Description	Applicable Feature			
		Image	OCR	E-mail	File
<b>Brightness</b>	Adjust the setting (-50 to 50) to get the best image. The default value of 0 represents an average and is usually suitable for most images. You can set the <b>Brightness</b> level by dragging the slider to the right or left to lighten or darken the image. You can also enter a value in the box to set the level. If the scanned image is too light, set a lower Brightness level and scan the document again. If the image is too dark, set a higher Brightness level and scan the document again.	Yes	Yes	Yes	Yes
<b>Contrast</b>	Adjust the setting (-50 to 50) to get the best image. The default value of 0 represents an average and is usually suitable for most images. You can increase or decrease the contrast level by moving the slider to the right or left. An increase emphasizes dark and light areas of the image, while a decrease reveals more details in grey areas. You can also enter a value in the box to set the <b>Contrast</b> .  <b>NOTE</b> The <b>Contrast</b> setting is only available when setting <b>Scan Type</b> to <b>Auto</b> , <b>Gray (Error Diffusion)</b> , <b>True Gray</b> or <b>24bit Color</b> .	Yes	Yes	Yes	Yes
<b>Default</b>	Restore all settings to their factory default values.	Yes	Yes	Yes	Yes
<b>Carrier Sheet Mode</b>	Scan the following documents using the Carrier Sheet. For this mode, you can select any setting other than <b>Auto</b> from the <b>Document Size</b> drop-down list.  <ul style="list-style-type: none"> <li>■ Large-sized Documents (A3, B4 and Ledger) Fold the document in half and insert it in the Carrier Sheet for 2-sided (duplex) scanning, then both front and back pages will be combined into a single page. Select <b>2 in 1(A4)</b> for an A3 document, <b>2 in 1(B5)</b> for a B4 document or <b>2 in 1(Letter)</b> for a Ledger document from the <b>Document Size</b> drop-down list.</li> <li>■ Important documents (photos, contracts)</li> <li>■ Thin paper (receipts)</li> <li>■ Irregular-shaped paper (clippings)</li> </ul> <b>NOTE</b> <ul style="list-style-type: none"> <li>• Load only one Carrier Sheet at a time.</li> <li>• Set the document in the center of the Carrier Sheet and align the top of the document with the top of the Carrier Sheet.</li> </ul>	Yes	Yes	Yes	Yes

Setting	Description	Applicable Feature			
		Image	OCR	E-mail	File
<b>Plastic Card Mode</b>	<p>Scan non-embossed cards, such as driver’s licenses or insurance cards, using these automatic settings:</p> <ul style="list-style-type: none"> <li>■ <b>Resolution: 600 x 600 dpi</b></li> <li>■ <b>Document Size: 2 in 1 (Auto)</b></li> <li>■ <b>2-sided Scanning: On (Short-edge binding)</b></li> <li>■ <b>Auto Deskew: Off</b></li> <li>■ <b>Multifeed Detection: Off</b></li> <li>■ <b>Auto Image Rotation: Off</b></li> </ul> <p><b>NOTE</b></p> <ul style="list-style-type: none"> <li>• If you want to scan a plastic card with different settings, set <b>Plastic Card Mode</b> off, <b>Resolution</b> to 600 dpi, and <b>Multifeed Detection</b> to Off.</li> <li>• Load only one plastic card at a time.</li> </ul>	Yes	Yes	Yes	Yes

6 Click the **Advanced Settings** button. The **Advanced Settings** dialog box appears.

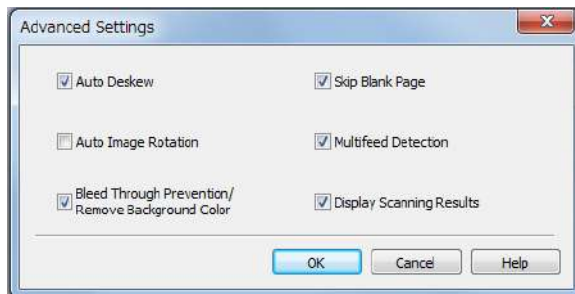

7 Change the settings. The following settings can be changed.

Setting	Description	Applicable Feature			
		Image	OCR	E-mail	File
<b>Auto Deskew</b>	Corrects the skew (within 5 degrees) of the scanned data.	Yes	Yes	Yes	Yes
<b>Auto Image Rotation</b>	Changes the direction of the document based on the text orientation.	Yes	Yes	Yes	Yes
<b>Bleed Through Prevention/Remove Background Color</b>	Prevents the Bleed Through phenomenon on a two-sided document, and also allows you to remove the base color of documents such as newspapers to make the scanned data more recognizable.	Yes	Yes	Yes	Yes
<b>Skip Blank Page</b>	Removes blank pages of the document from the scanning results.	Yes	Yes	Yes	Yes

Setting	Description	Applicable Feature			
		Image	OCR	E-mail	File
<b>Multifeed Detection</b>	Uses a ultrasonic sensor to detect when a multifeed has occurred. When this function detects a multifeed, confirm that the data scanned before the multifeed has been saved, and then start scanning again at the next page or the beginning of the document.	Yes	Yes	Yes	Yes
<b>Display Scanning Results</b>	Shows the numbers of total pages saved and blank pages skipped on your computer screen.	Yes	Yes	Yes	Yes

- 8 Click **OK** to close the **Advanced Settings** dialog box.
- 9 Click **OK** to close the **Device Scan Settings** dialog box.

## Change Scan to PC Settings (Macintosh)

- 1 Click the  (ControlCenter2) icon in the Dock. The **ControlCenter2** window appears.



- 2 While holding down the **Control** key, click a button for the Scan-to action you want to change (**Image**, **OCR**, **E-mail**, or **File**). The Scan-to action setting dialog box appears (the example below uses **Image**).
- 3 Click the **Device Button** tab.

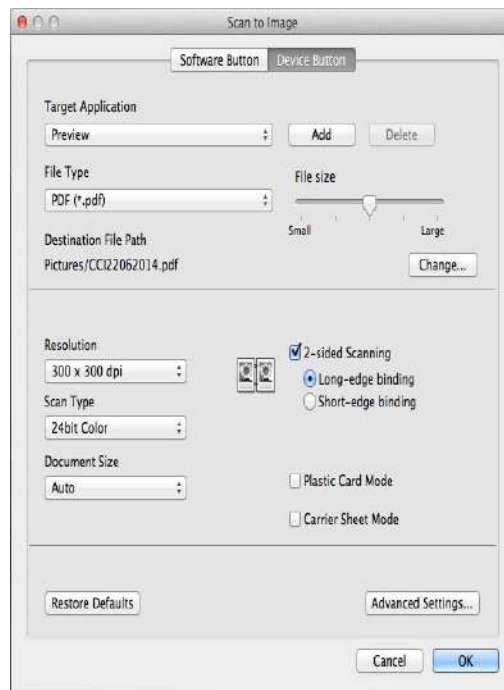

- 4 Change the settings.  
The following settings can be changed.

Setting	Description	Applicable Feature			
		Image	OCR	E-mail	File
<b>Target Application</b>	<p>Select which application is used to open scanned data. Only applications installed on your computer can be selected.</p> <ul style="list-style-type: none"> <li>■ <b>Add</b> button Add an application to the pop-up menu. Enter the <b>Application Name</b> (up to 30 characters) and select your preferred application by clicking the <b>Browse</b> button. Also select the <b>File Type</b> from the pop-up menu.</li> <li>■ <b>Delete</b> button Delete an application that you have added. Select the <b>Application Name</b> and click the <b>Delete</b> button.</li> </ul>	Yes	Yes	Yes	-
<b>File Type</b>	<p>Select the file type you want to use for the scanned data.</p> <p><b>NOTE</b></p> <ul style="list-style-type: none"> <li>• To save the document as a password-protected PDF, select <b>Secure PDF (*.pdf)</b> for <b>File Type</b> and then enter the password in the <b>Set PDF Password</b> dialog box.</li> <li>• Searchable PDF is a file format that includes the text data layer over a scanned image. This layer allows you to search the text on the image data. The OCR language setting must be set to match the language you want to make the searchable PDF for.</li> <li>• To save the document as a searchable PDF, select <b>Searchable PDF (*.pdf)</b> from the <b>File Type</b> drop-down list.</li> <li>• To save the document as a searchable PDF, Presto! PageManager must be installed on your computer. See <i>Installing Presto! PageManager</i> on page 109.</li> <li>• Several file types such as TIFF, TIFF Multi-Page, PDF, Secure PDF and JPEG support file size compression. Select <b>Uncompressed</b> or <b>Compressed</b> to adjust the file size for TIFF or TIFF Multi-Page. For PDF, Secure PDF and JPEG, use the slider to adjust the file size (not available for Scan to OCR).</li> </ul>	Yes	Yes	Yes	Yes
<b>File size</b>	<p>Adjust the <b>File size</b> by moving the slider to the right or left.</p> <p><b>NOTE</b></p> <p><b>File size</b> can be adjusted depending on your selected <b>File Type</b>.</p>	Yes	-	Yes	Yes

Setting	Description	Applicable Feature			
		Image	OCR	E-mail	File
<b>OCR Software</b>	Shows the application to extract the editable text data from the document.	-	Yes	-	-
<b>OCR Language</b>	Set to match the language of the scanned document's text.	-	Yes	-	-
<b>File Name</b>	Click the <b>Change</b> button for <b>Image</b> , <b>OCR</b> or <b>E-mail</b> . Enter a prefix for the file name if needed.	Yes	Yes	Yes	Yes
<b>Destination File Path</b>	Click the <b>Change</b> button and then the <b>Browse</b> button to change the folder you would like to save your scanned document to.	Yes	Yes	Yes	-
<b>Destination Folder</b>	Click <b>Browse</b> and browse to the folder you would like to save your scanned document to. Check <b>Show Folder</b> to automatically display the destination folder after scanning.	-	-	-	Yes
<b>Resolution</b>	Select a scanning resolution from the <b>Resolution</b> pop-up menu. Higher resolutions take more memory and transfer time, but produce a finer scanned image.	Yes	Yes	Yes	Yes
<b>Scan Type</b>	<p>Select from a range of scan color depth.</p> <p><b>Black &amp; White</b> Use for text or line art images.</p> <p><b>Gray (Error Diffusion)</b> Use for photographic images or graphics. (Error Diffusion is a method for creating simulated grey images without using true grey dots. Black dots are put in a specific pattern to give a grey appearance.)</p> <p><b>True Gray</b> Use for photographic images or graphics. This mode is more exact due to using up to 256 shades of grey.</p> <p><b>24bit Color</b> Uses up to 16.8 million colors to scan the image. Although using <b>24bit Color</b> creates an image with the most accurate color reproduction, it requires the most memory and has the longest transfer time.</p> <p><b>Auto</b> Uses suitable colors for your document automatically.</p>	Yes	Yes	Yes	Yes

Setting	Description	Applicable Feature			
		Image	OCR	E-mail	File
<b>Document Size</b>	<p>Document size is set to <b>Auto</b> by default. You can scan documents of any size without making any adjustments to <b>Document Size</b>. For faster scan speeds, you can select the exact size of your document from the <b>Document Size</b> pop-up menu.</p> <p><b>NOTE</b></p> <ul style="list-style-type: none"> <li>If you select a 1 to 2 document size, the scanned image will be divided into two documents that are half the size of the setting. For example, if you select <b>1 to 2 (A4)</b>, the scanned image will be divided into two A5-size documents.</li> <li>To do 1 to 2 scanning, unselect the <b>Auto Image Rotation</b> check box in the <b>Advanced Settings</b> dialog box.</li> <li>If you select a 2 in 1 document size, two scanned images will be combined into one document.</li> <li>You can select <b>Long Paper</b> when you configure the settings as following: <ul style="list-style-type: none"> <li><b>Auto Deskew:</b> Off</li> <li><b>2-sided Scanning:</b> Off</li> </ul> </li> </ul>	Yes	Yes	Yes	Yes
<b>Restore Defaults</b>	Restore all settings to their factory default values.	Yes	Yes	Yes	Yes
<b>Carrier Sheet Mode</b>	<p>Scan the following documents using the Carrier Sheet. For this mode, you can select any setting other than <b>Auto</b> from the <b>Document Size</b> pop-up menu.</p> <ul style="list-style-type: none"> <li>Large-sized Documents (A3, B4 and Ledger) Fold the document in half and insert it in the Carrier Sheet for 2-sided (duplex) scanning, then both front and back pages will be combined into a single page. Select <b>2 in 1 (A4)</b> for an A3 document, <b>2 in 1 (B5)</b> for a B4 document or <b>2 in 1 (Letter)</b> for a Ledger document from the <b>Document Size</b> pop-up menu.</li> <li>Important documents (photos, contracts)</li> <li>Thin paper (receipts)</li> <li>Irregular-shaped paper (clippings)</li> </ul> <p><b>NOTE</b></p> <ul style="list-style-type: none"> <li>Load only one Carrier Sheet at a time.</li> <li>Set the document in the center of the Carrier Sheet and align the top of the document with the top of the Carrier Sheet.</li> </ul>	Yes	Yes	Yes	Yes

Setting	Description	Applicable Feature			
		Image	OCR	E-mail	File
<b>Plastic Card Mode</b>	<p>Scan non-embossed cards, such as driver's licenses or insurance cards, using these automatic settings:</p> <ul style="list-style-type: none"> <li>■ <b>Resolution: 600 x 600 dpi</b></li> <li>■ <b>Document Size: 2 in 1 (Auto)</b></li> <li>■ <b>Auto Deskew: On</b></li> <li>■ <b>2-sided Scanning: On (Short-edge binding)</b></li> <li>■ <b>Multifeed Detection: Off</b></li> <li>■ <b>Auto Image Rotation: Off</b></li> </ul> <p><b>NOTE</b></p> <ul style="list-style-type: none"> <li>• If you want to scan a plastic card with different settings, set <b>Plastic Card Mode</b> off, <b>Resolution</b> to 600 dpi, and <b>Multifeed Detection</b> to Off.</li> <li>• Load only one plastic card at a time.</li> </ul>	Yes	Yes	Yes	Yes

5 Click the **Advanced Settings** button. The **Advanced Settings** dialog box appears.

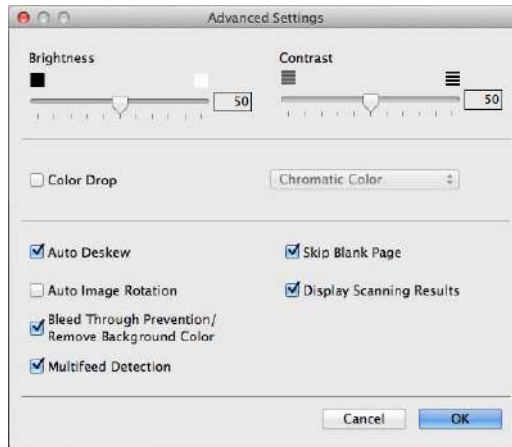

6 Change the settings. The following settings can be changed.

Setting	Description	Applicable Feature			
		Image	OCR	E-mail	File
<b>Brightness</b>	Adjust the setting (0 to 100) to get the best image. The default value of 50 represents an average and is usually suitable for most images. You can set the <b>Brightness</b> level by dragging the slider to the right or left to lighten or darken the image. If the scanned image is too light, set a lower Brightness level and scan the document again. If the image is too dark, set a higher Brightness level and scan the document again.	Yes	Yes	Yes	Yes

Setting	Description	Applicable Feature			
		Image	OCR	E-mail	File
<b>Contrast</b>	Adjust the setting (0 to 100) to get the best image. The default value of 50 represents an average and is usually suitable for most images. You can increase or decrease the contrast level by moving the slider to the right or left. An increase emphasizes dark and light areas of the image, while a decrease reveals more details in grey areas.  <b>NOTE</b> The <b>Contrast</b> setting is only available when setting <b>Scan Type</b> to <b>Auto, Gray (Error Diffusion), True Gray</b> or <b>24bit Color</b> .	Yes	Yes	Yes	Yes
<b>Color Drop</b>	Deletes specific colors from your scan data. Select one of the following:  ■ <b>Chromatic colors</b> Use to drop all colors except Black.  ■ <b>Red</b> Use to drop the Red color.  ■ <b>Green</b> Use to drop the Green color.  ■ <b>Blue</b> Use to drop the Blue color.  ■ <b>Custom</b> Select the color that you want to remove.	Yes	Yes	Yes	Yes
<b>Auto Deskew</b>	Corrects the skew (within 5 degrees) of the scanned data.	Yes	Yes	Yes	Yes
<b>Auto Image Rotation</b>	Changes the direction of the document based on the text orientation.	Yes	Yes	Yes	Yes
<b>Bleed Through Prevention/ Remove Background Color</b>	Prevents bleedthrough on a two-sided document, and also allows you to remove the base color of documents such as newspapers to make the scanned data more recognizable.	Yes	Yes	Yes	Yes
<b>Skip Blank Page</b>	Removes blank pages of the document from the scanning results.	Yes	Yes	Yes	Yes
<b>Multifeed Detection</b>	Uses a ultrasonic sensor to detect when a multifeed has occurred. When this function detects a multifeed, confirm that the data scanned before the multifeed has been saved, and then start scanning again at the next page or the beginning of the document.	Yes	Yes	Yes	Yes
<b>Display Scanning Results</b>	Shows the numbers of total pages saved and blank pages skipped on your computer screen.	Yes	Yes	Yes	Yes

7 Click **OK**.

8 Click **OK** to close the setting dialog box.

## Scanner Shortcuts (ADS-2500We only)

### Add a Shortcut

---

Eight shortcut tabs are available, each holding up to six shortcuts.

- 1 Press **Shortcuts**.
- 2 Press a tab from 1 to 8.
- 3 Press .
- 4 Do one of the following:
  - Press **Scan**.
    1. Press **▲** or **▼** until you find the shortcut type you want to create.
    2. Press the shortcut type, and then press **OK**.
    3. Go to step 5.
  - Press **Scan to Web**.

You must set up Brother Web Connect first. See the Network User's Guide.

### NOTE

---

Occasionally, updates or announcements about Brother Web Connect features will be displayed on the LCD.

Read the information, and then press **OK**.

---

- 5 Do one of the following:
  - to USB
    1. Press **Options**.
    2. **Configure the following settings:** 2-sided Scan, Scan Type, Resolution, Document Size, File Name, File Size, Auto Deskew, Skip Blank Page.
    3. Press **OK**.
  - to PC (File), to PC (OCR), to PC (Image) and to PC (E-mail)
    1. Select the type of scan and the destination computer.
    2. Go to step 7.
  - to E-mail Server
    1. Press **Manual** or **Address Book** to enter email address. Then press **OK**.
    2. Press **Options**.
    3. **Configure the following settings:** 2-sided Scan, Scan Type, Resolution, File Type, Document Size, File Size, Auto Deskew, Skip Blank Page.
    4. Press **OK**.

■ to Network and to FTP

1. Select a profile name.
2. Go to step 7

- 6 Press Save as Shortcut.
- 7 Confirm your settings, and then press OK. The software keyboard appears on the LCD.
- 8 Enter a shortcut name, and then press OK.
- 9 Press the check box to save this as a One Touch Shortcut and then press OK.



## NOTE

- A One Touch Shortcut will immediately start the configured operation and not prompt you to change any settings.
- A One Touch Shortcut is made in green color.

- 10 Press OK.



## Edit, Rename or Delete a Shortcut

- 1 Press Shortcuts.
- 2 Press the shortcut that you want to edit for one second.
- 3 Do one of the following:
  - Edit\*  
Follow the step 5 on page 160.  
Follow the step 9 on page 161 to save this as a One Touch Shortcut.  
\* Not available for Scan to Web.
  - Delete  
The LCD displays the shortcut you are deleting. Press Yes.
  - Rename  
The software keyboard appears on the LCD.  
Enter a new shortcut name, and then press OK.

## Monitor the Machine's Status from Your Computer (Windows®)

The Status Monitor utility is a configurable software tool for monitoring the status of one or more devices, allowing you to get immediate notification of error messages.

Do one of the following:

- Double-click the  (**Status Monitor**) icon in the task tray.
- Click  (**Brother Utilities**) on your desktop, and then click the drop-down list and select your model name (if not already selected). Click **Tools** in the left navigation bar, and then click **Status Monitor**. The Brother Status Monitor screen appears

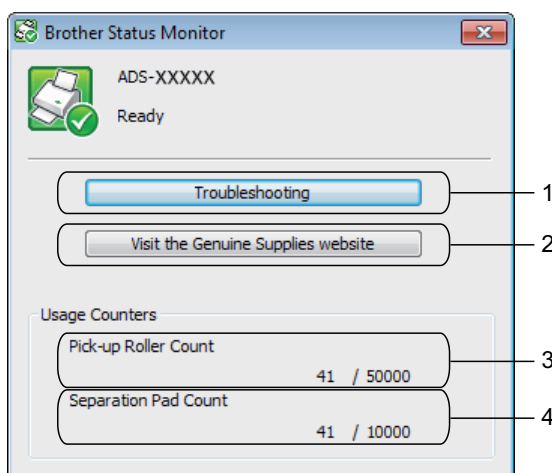

### 1 Troubleshooting

Click to access the Status Monitor troubleshooting web site.

### 2 Visit the Genuine Supplies website

Click to access the Brother genuine supplies web site.

### 3 Pick-up Roller Count

Displays Pick-up Roller use.

### 4 Separation Pad Count

Displays Separation Pad use.

## NOTE

For more information about using the Status Monitor software, right-click the  (**Status Monitor**) icon and select **Help**.

## Error Notifications





---

Right-click the  (Status Monitor) icon and select **Enable error notifications**.

## Status Monitor Indicators

---

The **Brother Status Monitor** icon changes color based on your machine's status.

	A green icon indicates that your scanner is in a normal stand-by state.
	A yellow icon indicates a warning.
	A red icon indicates an error has occurred.
	A gray icon indicates that your scanner is offline.

## Monitor the Machine's Status from Your Computer (Macintosh)

The Status Monitor utility is a configurable software tool for monitoring the status of a device, allowing you to get immediate notification of error messages such as document jam.

- 1 Click the  (ControlCenter2) icon in the Dock. The **ControlCenter2** window appears.
- 2 Click the **DEVICE SETTINGS** tab.



- 3 Click the **Status Monitor** button.  
The Status Monitor window appears and display the status of your Brother machine.

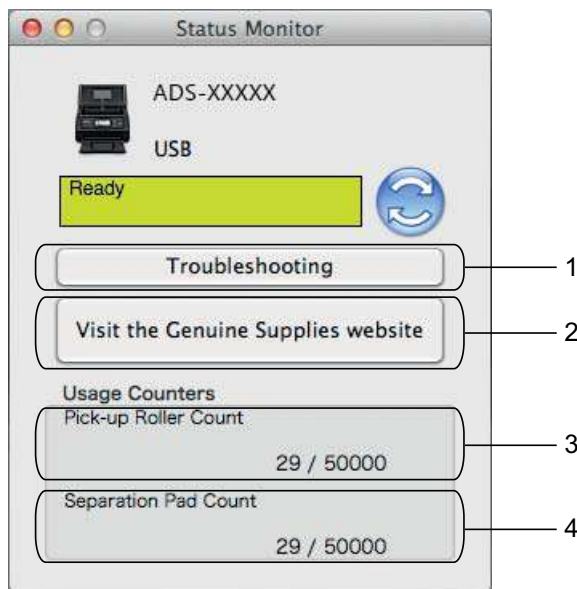

#### 1 Troubleshooting

Click to access the troubleshooting web site by clicking the **Troubleshooting** button.

#### 2 Visit the Genuine Supplies website

Click to access the Brother genuine supplies web site by clicking the **Visit the Genuine Supplies website** button.

#### 3 Pick-up Roller Count

Displays the Pick-up Roller replacement cycle.

#### 4 Separation Pad Count

Displays the Separation Pad replacement cycle.

## Turn the AutoLoad Feature On/Off (ControlCenter2)

- 1 Click the  (ControlCenter2) icon in the Dock. The **ControlCenter2** window appears.



- 2 Click **Configuration**, and then select **Preferences**. The **ControlCenter2 Preferences** window appears.



- 3 Select (or clear) the **Start ControlCenter on computer startup** check box.
- 4 Click **OK**.

## Set Up the Brother Machine from Your Computer

The Remote Setup application lets you configure many machine settings from your computer. When you start the Remote Setup application, the settings on your Brother machine will be downloaded automatically to your computer and displayed on the screen. If you change the settings on your computer, you can upload them directly to the machine.

### NOTE

- If an error dialog box appears, Remote Setup will not start. Correct the error and then try to start Remote Setup again.
- Windows®
  - If your computer is protected by a firewall, and is unable to use Remote Setup, you may need to configure the firewall settings to allow communication through port number 137 and 161.
  - If you are using Windows® Firewall and you installed MFL-Pro Suite from the DVD-ROM, the necessary Firewall settings have already been made.

#### 1 Start the ControlCenter application.

- Windows®

- 1 Click the  (ControlCenter4) icon in the task tray and then select **Open** from the menu. The **ControlCenter4** window appears.
- 2 Click the **Device Settings** tab (the example below uses **Home Mode**).

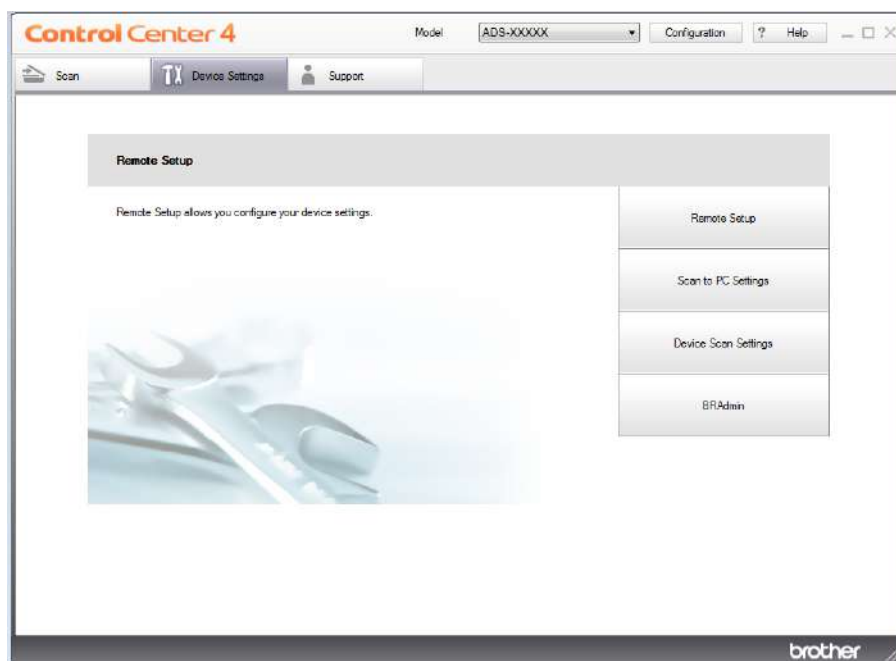

■ Macintosh

- 1 Click the  (ControlCenter2) icon in the Dock. The **ControlCenter2** window appears.
- 2 Click the **DEVICE SETTINGS** tab.



- 2 Click the **Remote Setup** button. The Remote Setup window appears.

**NOTE**

You can also start Remote Setup by following the instructions below:

- Windows®

Click  (**Brother Utilities**) on your desktop, and then click the drop-down list and select your model name (if not already selected). Click **Tools** in the left navigation bar, and then click **Remote Setup**.

- Macintosh

In the **Finder** menu bar, click **Go > Applications > Brother**, and then double-click the **Remote Setup** icon.

3 Select a menu in the folder tree and configure the settings as needed (the example below uses **General Setup** in Windows®).

■ **OK**

Click to start uploading data to the machine and exit the Remote Setup application. If an error message is displayed, re-enter the correct data, and then click **OK**.

■ **Cancel**

Click to exit the Remote Setup application without uploading data to the machine.

■ **Apply**

Click to upload data to the machine without exiting the Remote Setup application.

(ADS-2000e)

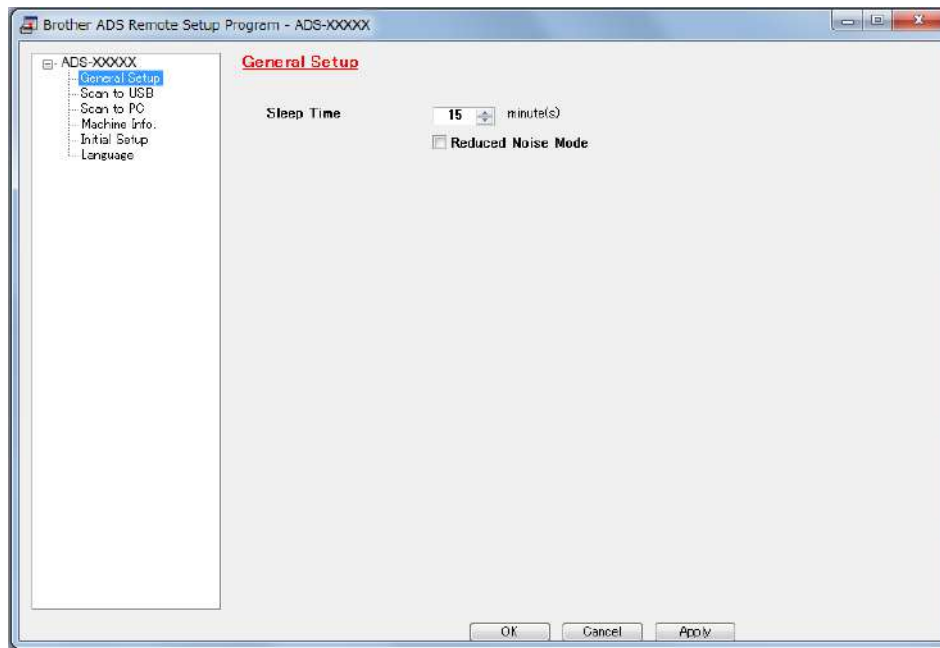

(ADS-2500We)

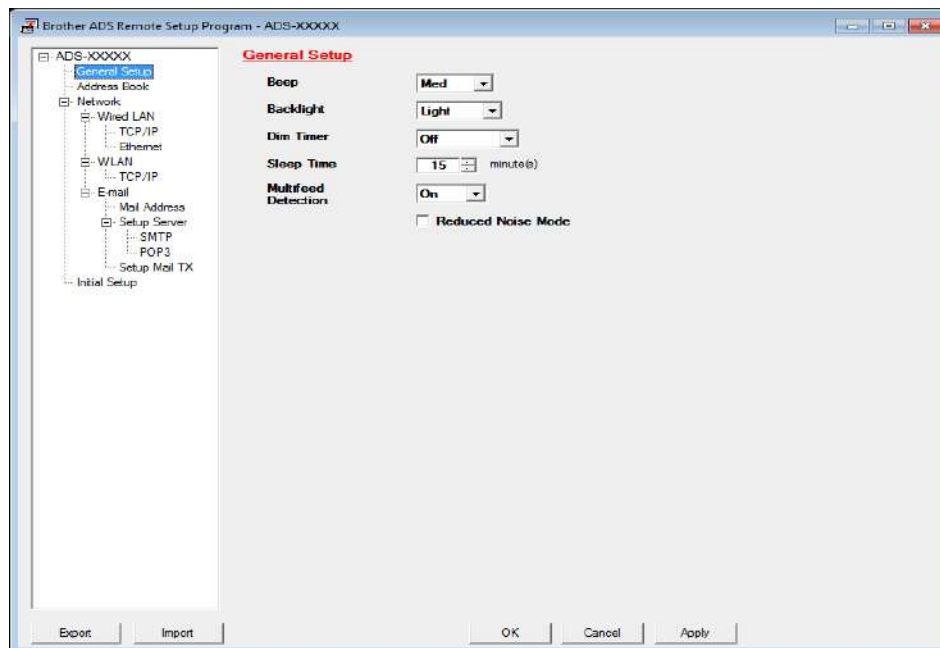

## NOTE

- Click the **Export** button to save all settings for your machine.
- (Windows®)

If your computer is protected by a firewall, and is unable to use **Remote Setup**, you may need to configure the firewall settings to allow communication through port number 137.

- If you are using Windows® Firewall and you installed MFL-Pro Suite from the DVD-ROM, the necessary Firewall settings have already been made.
- (Macintosh)

If you need to change the machine that was registered to your computer during the installation of Full Driver & Software Package (see the Quick Setup Guide), or if the network environment has changed, you must specify the new machine. Open the **Device Selector** and choose the new machine. (For network users only.) (See *Configure Network Scanning for Macintosh* on page 42.)

# 8

## Routine Maintenance

### Clean the Outside of the Machine

- 1 Wipe the outside of the machine with a dry, soft, lint-free cloth to remove dust.

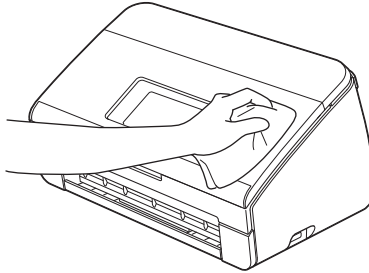

- 2 Open the Top Cover. Wipe the Control Panel with a dry, soft, lint-free cloth to remove dust.

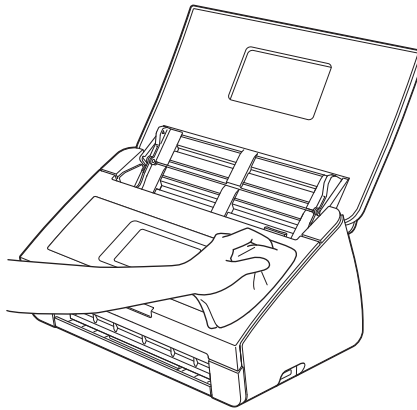

- 3 Close the Top Cover.

- 4 Pull the Output Tray ① out and unfold the Document Stopper ②.

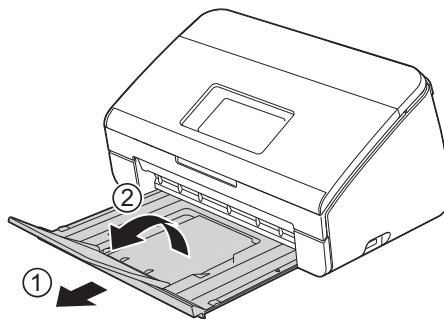

- 5 Wipe the inside of the Output Tray with a dry, soft, lint-free cloth to remove dust.

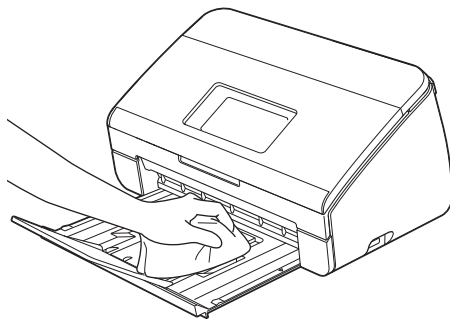

- 6 Fold the Document Stopper ① and firmly insert the Output Tray ② into the machine.

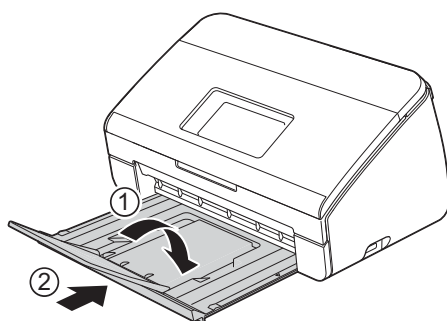

## Clean the Scanner

A spot of dirt or correction fluid on the glass strip may cause poor quality scans. Clean the inside of the scanner if a vertical line appears in the scanned data or if areas are missing in the scanned data.

- 1 Unplug the machine from the AC power outlet.
- 2 Open the Top Cover ① and the Front Cover ②.

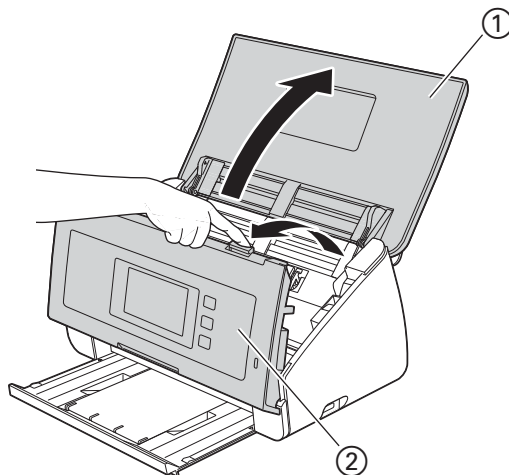

- 3 In the ADF unit, clean the glass strips ① ② with a soft lint-free cloth moistened with water.

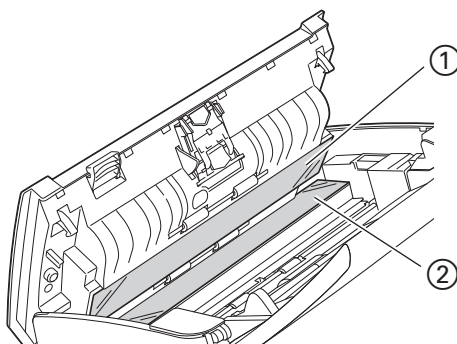

- 4 Press and hold the buttons ① on the inside of the Front Cover and then pull the Separation Pad Cover ② down.

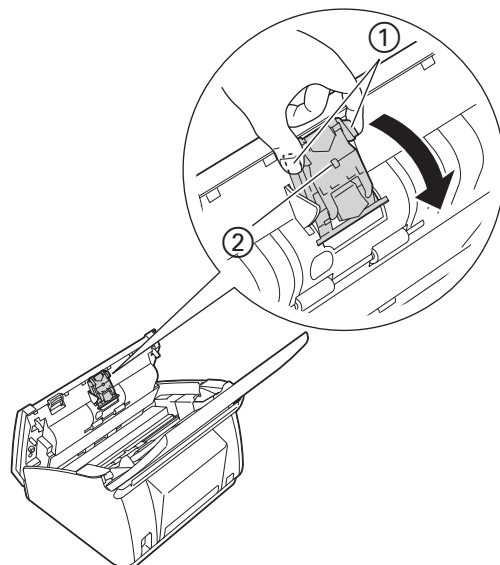

## IMPORTANT

Be careful when touching the Separation Pad and its surrounding area in the machine. Otherwise, you could cause injury to you and serious damage to the machine.

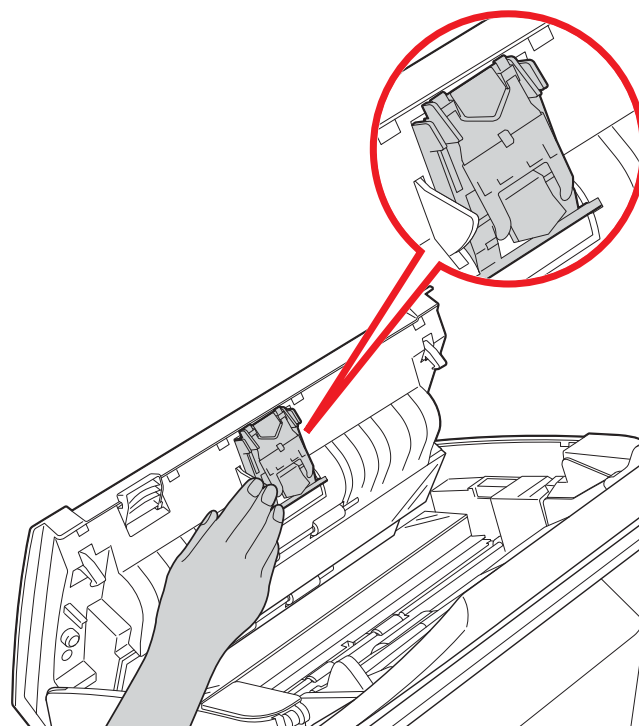

- 5 Press and hold the green buttons ① of the Separation Pad and then pull the Separation Pad ② upward.

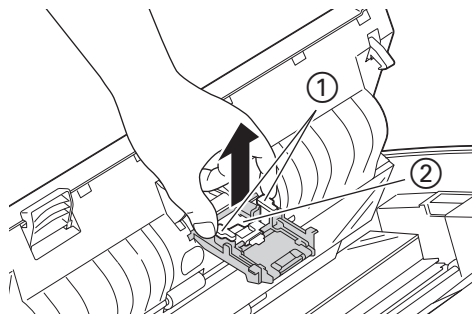

- 6 Clean the Separation Pad with a soft lint-free cloth slightly moistened with water.
- 7 Attach the Separation Pad to the Separation Pad Cover.

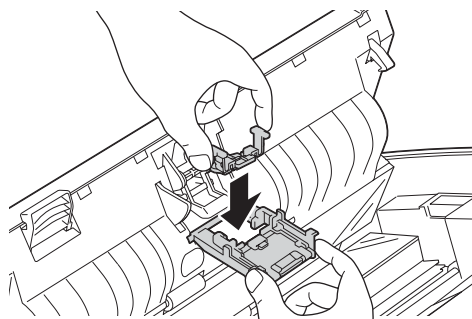

- 8 Securely close the Separation Pad Cover until the hooks fit into the Front Cover.
- 9 Hold both sides of the Pick-up Roller Cover ① and pull the cover down.

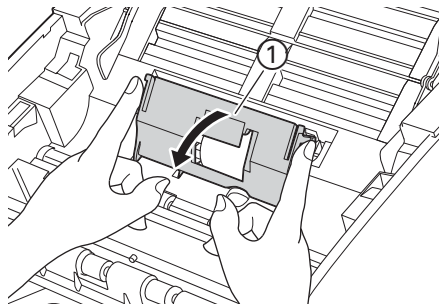

- 10 Slide the Pick-up Roller ① all the way to the right.

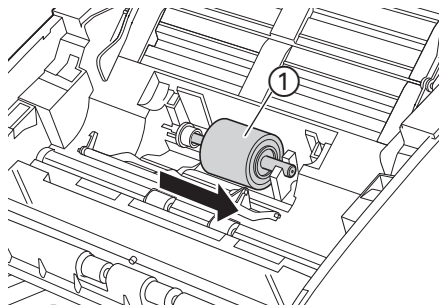

- 11 The holder of the Pick-up Roller has a narrow opening, and the shape of the shaft of the Pick-up Roller matches this opening. Rotate the Pick-up Roller until you can fit the shaft into the opening of the holder.

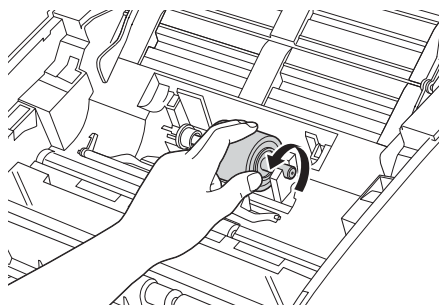

- 12 Pinch and pull the Pick-up Roller out of the machine.

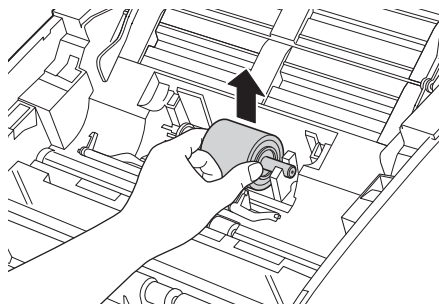

- 13 Clean the Pick-up Roller with a soft lint-free cloth slightly moistened with water.

- 14 Place the Pick-up Roller into the machine.

**NOTE**

Confirm the left and right sides of the Pick-up Roller before attaching it.

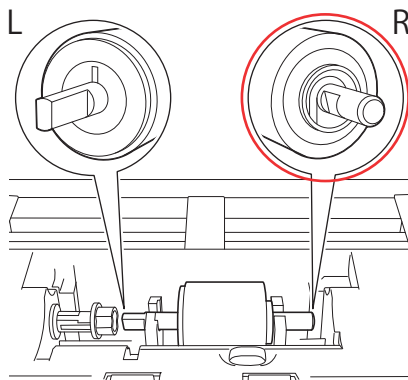

- 15 Slide the Pick-up Roller ① to the left edge while turning the Pick-up Roller.

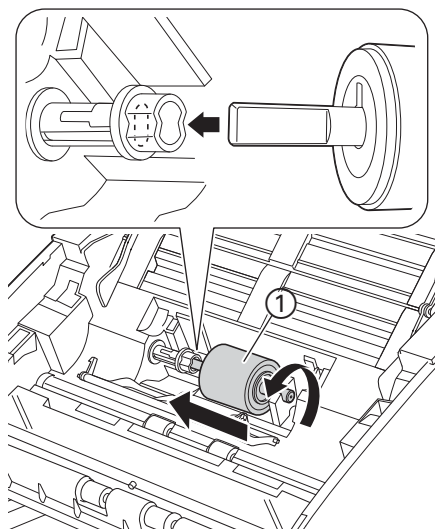

- 16 Close the Pick-up Roller Cover.
- 17 Close the Front Cover and the Top Cover.

## NOTE

You can clean the glass strips with a non-flammable glass cleaner. When finished, run your fingertip over the glass to see if you can feel anything on it. If you feel dirt or debris, clean the glass again, concentrating on that area. You may need to repeat the cleaning process three or four times. To test, scan a document after each cleaning attempt.



When there is a spot of dirt or correction fluid on the glass strip the scanned sample shows a vertical line.





After the glass strip is cleaned the vertical line is gone.

## Replace Supplies

The Status Monitor will alert you when the machine detects that supplies are near the end of their life.

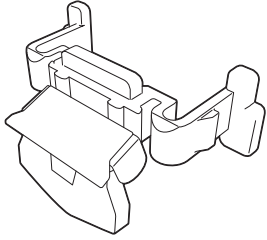
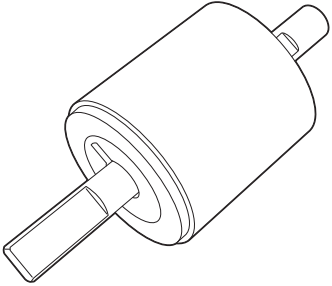
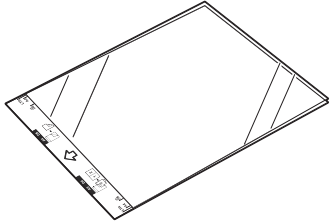
### Part Names, Numbers, and Life Cycles

No.	Part Name	Part No.	Standard Replacement Cycle
1	Separation Pad 	SP-A0001	50,000 sheets
2	Pick-up Roller 	PUR-A0001	50,000 sheets
3	Carrier Sheet 	CS-A3001	500 times
4	Plastic Card Carrier Sheet 	CS-CA001	500 times

---

**NOTE**

The Standard Replacement Cycle may vary depending on the usage environment, type of documents, and how often documents are scanned.

---

These parts are available at most Brother retailers. If you cannot find the part you need and you have a Visa, MasterCard, Discover, or American Express credit card, you can order parts directly from Brother. Visit us online for a complete selection of the Brother parts and supplies that are available for purchase.

---

**NOTE**

In Canada, only Visa and MasterCard are accepted.

---

**In USA:** 1-877-552-MALL (1-877-552-6255)  
1-800-947-1445 (fax)

<http://www.brothermall.com>

**In Canada:**

<http://www.brother.ca>

## Check Supplies Replacement Cycle (ADS-2000e)

Start the Status Monitor application.

■ Windows®

Double-click the  (**Status Monitor**) icon in the task tray.

The **Status Monitor** window appears.

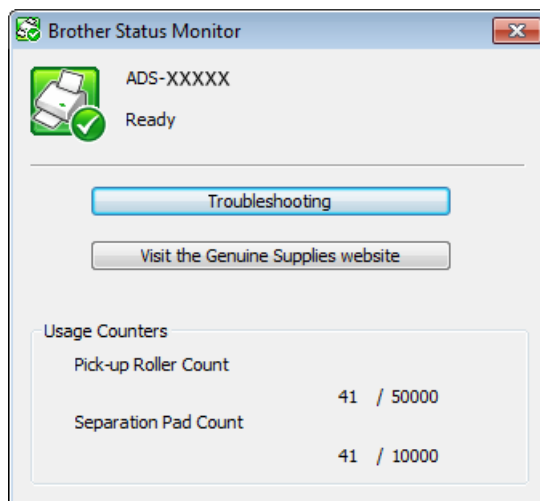

■ Macintosh

1 Click the  (ControlCenter2) icon in the Dock. The **ControlCenter2** window appears.

2 Click the **DEVICE SETTINGS** tab.



- 3 Click the **Status Monitor** button.  
The Status Monitor window appears.

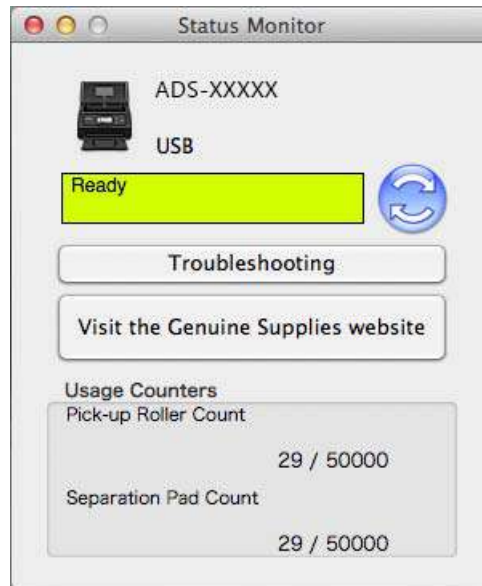

## NOTE

If the LED indications warn you to replace the Separation Pad and/or the Pick-up Roller, order the necessary parts and then replace the used parts with new ones.

## Check Supplies Replacement Cycle (ADS-2500We)

- 1 On the scanner's LCD, press .
- 2 Press ▲ or ▼ to display Machine Info.
- 3 Press Machine Info.
- 4 Press Usage Counters. The LCD displays Separation Pad Count and Pick-up Roller Count.

## NOTE

If the LCD indications warn you to replace the Separation Pad and/or the Pick-up Roller, order the necessary parts and then replace the used parts with new ones.

## Replace the Separation Pad

Your machine is equipped with a scan counter that automatically counts how many times the machine has scanned. When the machine scans 50,000 times, the Status Monitor displays a message to remind you to replace the Separation Pad.

- 1 Open the Top Cover ① and the Front Cover ②.

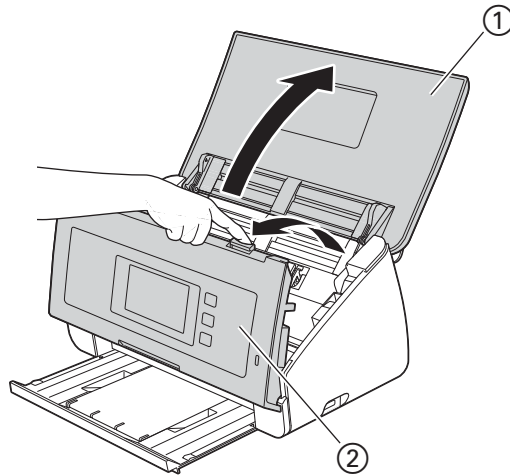

- 2 Press and hold the buttons ① on the inside of the Front Cover and then pull the Separation Pad Cover ② down.

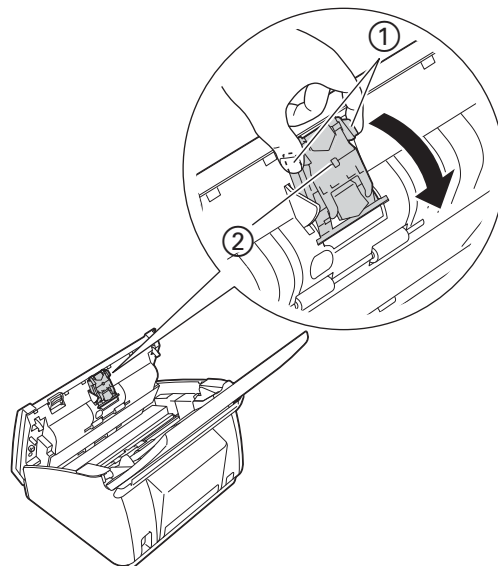

## IMPORTANT

Be careful when touching the Separation Pad and its surrounding area in the machine. Otherwise, you could cause injury to you and serious damage to the machine.

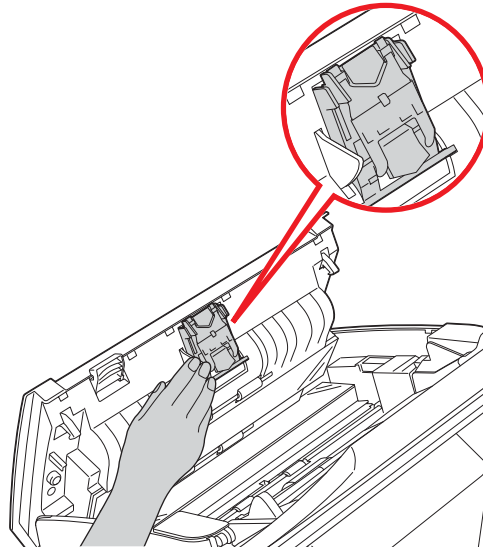

- 3 Press and hold the green buttons ① of the Separation Pad and then pull the Separation Pad ② upward.

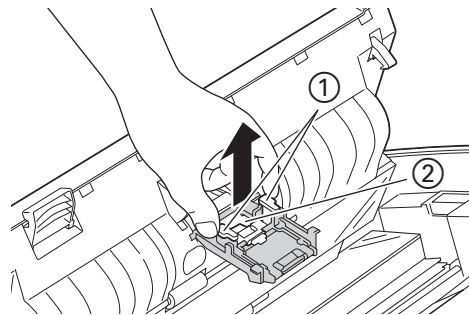

- 4 Attach a new Separation Pad to the Separation Pad Cover.

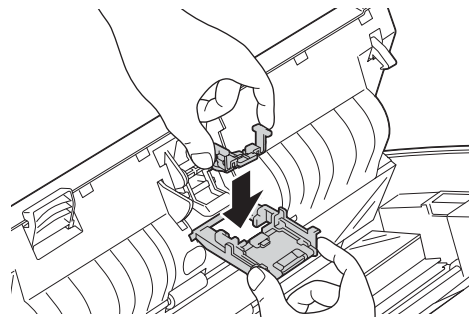

- 5 Securely close the Separation Pad Cover until the hooks fit into the Front Cover.

- 6 Close the Front Cover and the Top Cover.
- 7 Reset the counter (see *Reset the Usage Counters (ADS-2000e)* on page 188).

## NOTE

Confirm the following:

- The value of Separation Pad Count is 0 (see *Check Supplies Replacement Cycle (ADS-2000e)* on page 181).
- The error message on the Status Monitor has been cleared.
- The LCD or LED indications does not indicate Replace Pad and Replace Parts.

## Replace the Pick-up Roller

Your machine is equipped with a scan counter that automatically counts how many times the machine has scanned. When the machine scans 50,000 times, the Status Monitor displays a message to remind you to replace the Pick-up Roller.

- 1 Open the Top Cover ① and the Front Cover ②.

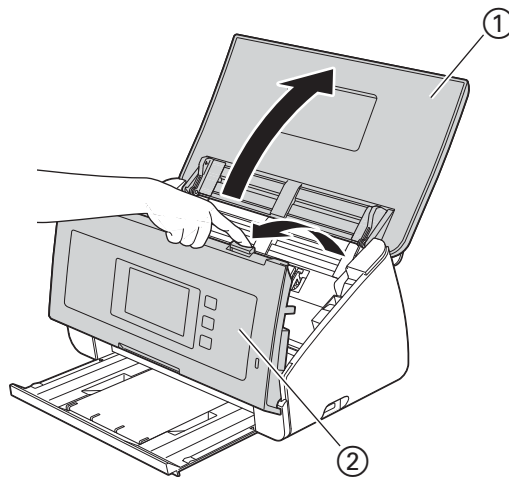

- 2 Hold the both sides of the Pick-up Roller Cover ① and then pull the cover down.

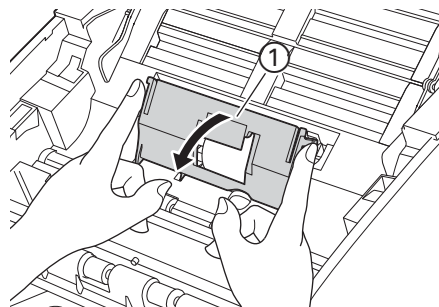

- 3 Slide the Pick-up Roller ① all the way to the right.

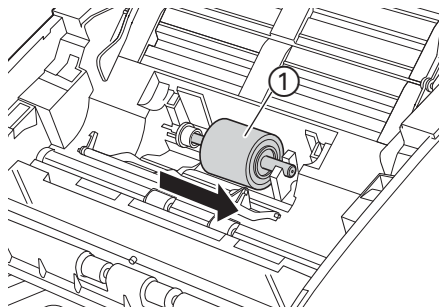

- 4 The holder of the Pick-up Roller has a narrow opening, and the shape of the shaft of the Pick-up Roller matches this opening. Rotate the Pick-up Roller until you can fit the shaft into the opening of the holder.

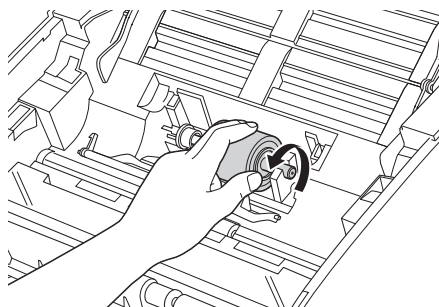

- 5 Pinch and pull the Pick-up Roller out of the machine.

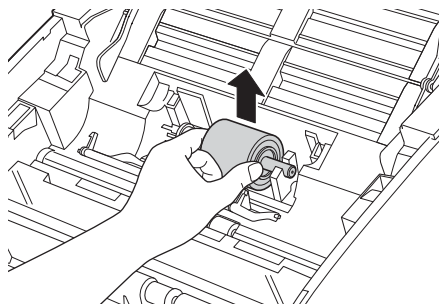

- 6 Place a new Pick-up Roller into the machine.

**NOTE**

Identify the left and right sides of the Pick-up Roller before attaching it.

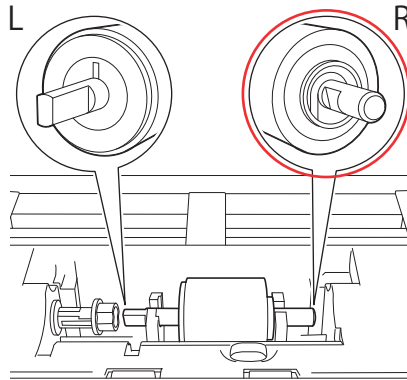

- 7 Slide the Pick-up Roller ① to the left edge while turning the Pick-up Roller.

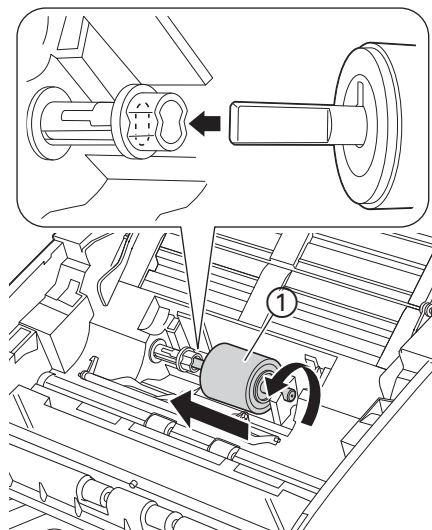

- 8 Close the Pick-up Roller Cover.
- 9 Close the Front Cover and the Top Cover.
- 10 Reset the counter (see *Reset the Usage Counters (ADS-2000e)* on page 188).

**NOTE**

Confirm the following:

- The value of Pick-up Roller Count is 0 (see *Check Supplies Replacement Cycle (ADS-2000e)* on page 181).
- The error message on the Status Monitor has been cleared.
- The LCD or LED indications does not indicate Replace Roller and Replace Parts.

## Reset the Usage Counters (ADS-2000e)

- 1 Start ControlCenter.
  - Windows®
- 1 Click the  (ControlCenter4) icon in the task tray and then select **Open** from the menu. The **ControlCenter4** window appears.
- 2 Click the **Device Settings** tab (the example below uses **Home Mode**).

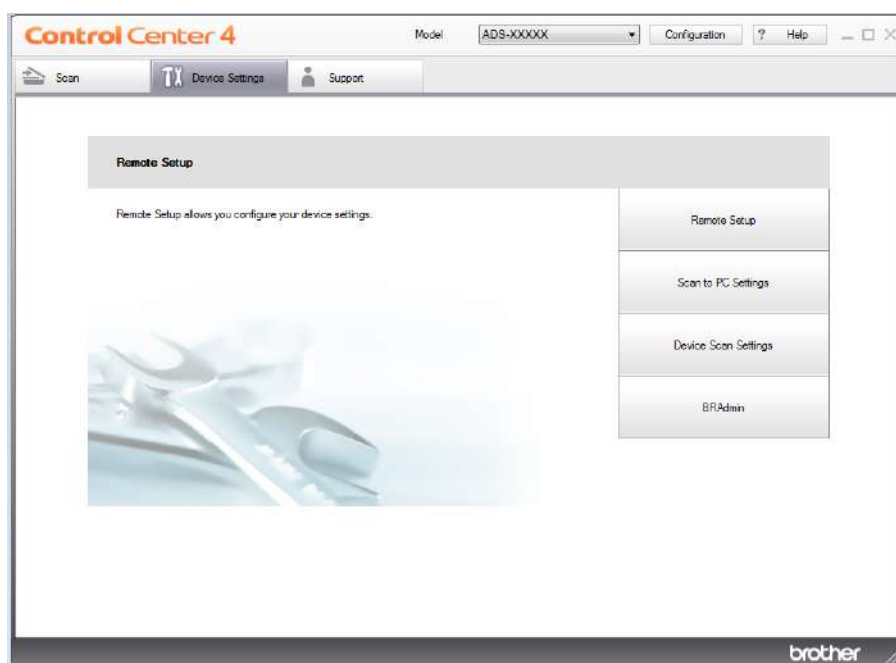

- Macintosh
- 1 Click the  (ControlCenter2) icon in the Dock. The **ControlCenter2** window appears.
  - 2 Click the **DEVICE SETTINGS** tab.



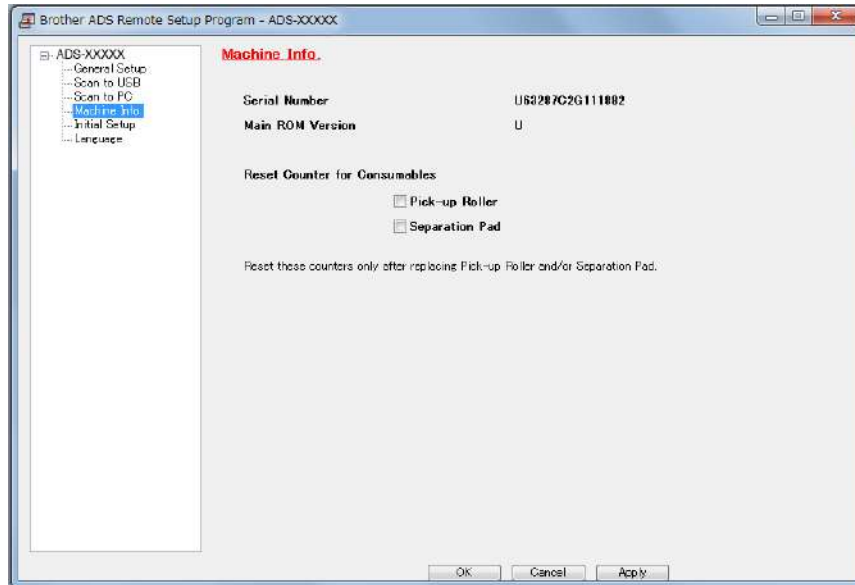

- 2 Click the **Remote Setup** button. The Remote Setup window appears.
- 3 Select **Machine Info.** in the folder tree and then configure scan settings as needed (the example below uses Windows®).



- 4 Do one of the following:
  - To reset the Separation Pad counter, select the **Separation Pad** check box.
  - To reset the Pick-up Roller counter, select the **Pick-up Roller** check box.
- 5 Click **Apply**.
- 6 Click **OK**.

## Reset the Usage Counters (ADS-2500We)

- 1 On your scanner's LCD, press .
- 2 Press ▲ or ▼ to display Machine Info.
- 3 Press Machine Info.
- 4 Press Usage Counters.
- 5 Do one of the following:
  - To reset the Separation Pad counter, press Separation Pad Count.
  - To reset the Pick-up Roller counter, press Pick-up Roller Count.
- 6 When the LCD displays a confirmation message, press Yes.
- 7 Press .

## Packing and Shipping the Machine

When you transport the machine, use the packing materials that came with your machine. If you do not pack the machine correctly, any damage that may occur in transit may not be covered by your warranty. The machine should be adequately insured with the carrier.

- 1 Close the Panel Cover gently.

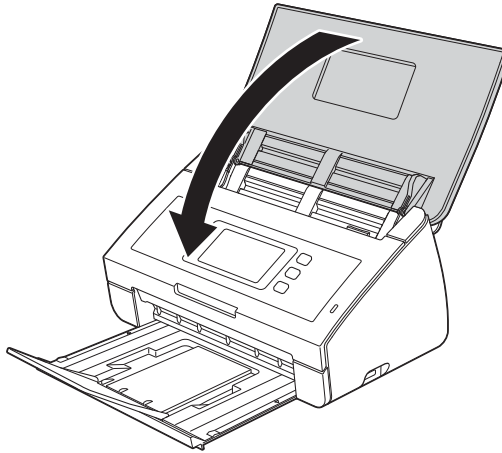

- 2 Fold the Document Stopper into the Output Tray and firmly push the Output Tray into the machine.

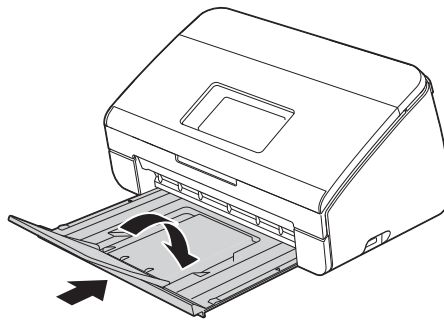

- 3 Wrap the machine in the original bag.

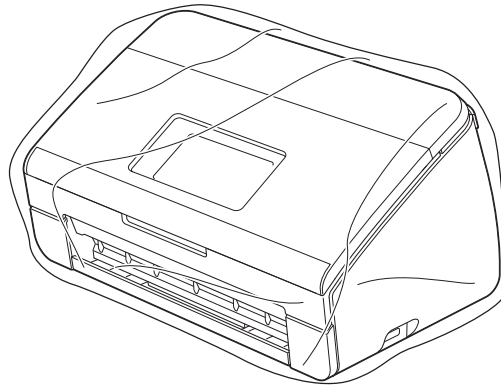

- 4 Pack the machine and the printed materials in the original carton with the original packing material as shown below.

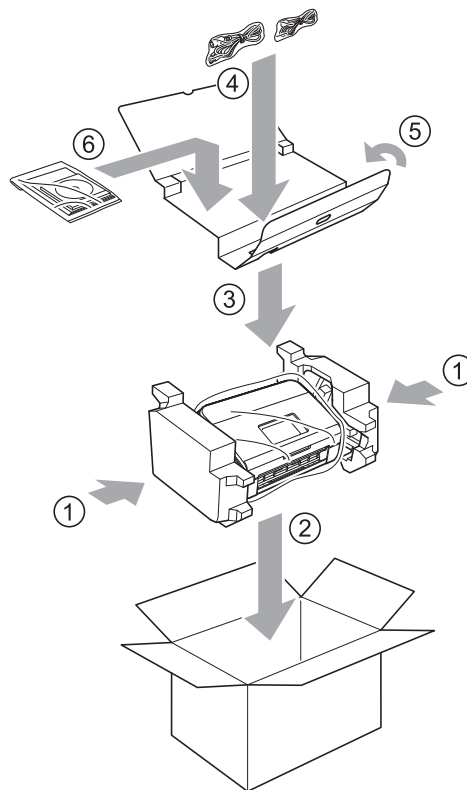

**NOTE**

If you are returning your machine to Brother as part of the Exchange Service, pack only the machine. Keep all separate parts (power cord, Carrier Sheet and USB cable) and printed materials to use with your “Exchange” machine.

- 5 Close the carton and tape it shut.

## Identify Your Problem

### First, check the following:

- The AC power cord is connected properly and the machine is turned on.
- All of the protective parts have been removed.
- The Front Cover, Separation Pad Cover and Pick-up Roller Cover are completely closed.
- The interface cable is securely connected to the machine and the computer.
- The correct driver for the machine has been installed.
- The computer is connected to the correct port on the machine.

## Error and Maintenance Messages

As with any sophisticated office product, errors may occur and consumable items may need to be replaced. If this happens, your machine identifies the problem and shows an error message. The most common error and maintenance messages are shown below (the messages will be displayed on Status Monitor or the LCD of the machine (ADS-2500We only)).

You can correct most errors and clear routine maintenance messages by yourself. If you need more help, the Brother Solutions Center offers the latest FAQs and troubleshooting tips.



Visit <http://support.brother.com>



### NOTE

(For ADS-2000e users only)

See also *LED Indications (ADS-2000e only)* on page 213.

Error message	Cause	Action
Out of Memory	The machine's memory is full.	<p>To clear the error, do one of the following:</p> <ul style="list-style-type: none"> <li>■ Press any button (ADS-2000e) or  (ADS-2500We).</li> <li>■ Turn the machine off and then on by unplugging the machine from the AC power outlet and then plugging the machine in again.</li> </ul> <p>To prevent the error, do one of the following:</p> <ul style="list-style-type: none"> <li>■ Reduce the numbers of your documents.</li> <li>■ Set resolution setting or file size smaller.</li> </ul>
Replace Pad	The Separation Pad has been used over 50,000 times.	Replace the Separation Pad with a new one. Scanning errors may occur if you do not replace the part. See <i>Replace the Separation Pad</i> on page 183.

Error message	Cause	Action
Replace Roller	The Pick-up Roller has been used over 50,000 times.	Replace the Pick-up Roller with a new one. Scanning errors may occur if you do not replace the part. See <i>Replace the Pick-up Roller</i> on page 185.
Replace Parts	Both the Separation Pad and the Pick-up Roller have been used over 50,000 times.	Replace the Separation Pad and the Pick-up Roller with new ones. Scanning errors may occur if you do not replace the parts. See <i>Replace the Separation Pad</i> on page 183 and <i>Replace the Pick-up Roller</i> on page 185.
Unable to Scan XX (XX is an error code.)	A machine error is occurring.	Turn the machine off and then on, and then try to scan again. If the error is not cleared after turning the machine off and then on, make a note of the error message and report it to your Brother dealer or Brother Customer Service (see <i>For Customer Service</i> on page ii).
Document Jam/too Long	<ul style="list-style-type: none"> <li>■ The Document Guides are not set to the correct document size.</li> <li>■ The settings are not suitable for your document.</li> <li>■ Paper dust has accumulated on the surface of the Pick-up Roller or Separation Pad.</li> </ul>	<p>Clear the document jam (see <i>Document Jam</i> on page 195) and then do the following:</p> <ul style="list-style-type: none"> <li>■ Adjust the Document Guides to fit the width of the document. When Scan Size is set to Auto and you are scanning a document that contains multiple page sizes, insert narrow pages straight and as close to the center of the machine as possible. If the document will not be fed straight, use Continuous Scanning.</li> <li>■ Confirm the settings. See <i>Important in Document Jam</i> on page 195.</li> <li>■ Clean the Pick-up Roller and Separation Pad. See <i>Clean the Scanner</i> on page 173.</li> </ul>
Multifeed	Multiple pages were fed at the same time.	Clear the Multifeed. See <i>Document Jam</i> on page 195.
Unusable Device	An unusable device is inserted in the USB port.	Disconnect the device. Turn the machine off and then on by unplugging the machine from the AC power outlet and then plugging the machine in again.
Unusable USB Device	An unsupported USB device is inserted in the USB port.	Remove the unsupported USB device, such as a mouse or mobile device that does not support USB flash drive mode, from the USB port.
USB Hub Not Supported	A hub or USB flash drive with a hub is inserted in the USB port.	Remove the unsupported device, such as a USB hub or USB flash drive with a hub, from the USB port.
Insufficient USB Storage	The inserted USB flash drive is full.	Press any button (ADS-2000e) or  (ADS-2500We) and then do one of the following: <ul style="list-style-type: none"> <li>■ Delete unused files or folders from the USB flash drive and then try again.</li> <li>■ Use a USB flash drive that has available space.</li> </ul>
USB Access Error	The USB flash drive was removed while it was being accessed.	Press any button (ADS-2000e) or  (ADS-2500We).

Error message	Cause	Action
USB Write-protected	The inserted USB flash drive is write-protected.	Remove the write-protected USB flash drive, press any button (ADS-2000e) or  (ADS-2500We) and then do one of the following: <ul style="list-style-type: none"> <li>■ Turn off the USB flash drive's write-protection and then try again.</li> <li>■ Use a USB flash drive that is not write-protected.</li> </ul>
Too Many Files on USB	Your machine cannot save to a USB flash drive if it contains too many files.	Remove the USB flash drive, press any button (ADS-2000e) or  (ADS-2500We). Delete unused files or folders from the root folder of the USB flash drive and then try again.
File Name Cannot Be Used	The maximum sequential number for the file name has been reached.	Press any button (see <i>File Name Cannot Be Used</i> on page 220) (ADS-2000e) or  (ADS-2500We) and then do one of the following: <ul style="list-style-type: none"> <li>■ Delete unused files from the USB flash drive and then try again.</li> <li>■ Change the file name. See <i>Save Scanned Documents on a USB Flash Drive</i> on page 123.</li> </ul>
No Profile set (ADS-2500We only)	No Scan to FTP profile or Scan to Network profile is registered.	Configure the Scan to FTP profile or the Scan to Network profile before using Scan to FTP or Scan to Network. See <i>Scan Documents to an FTP Server (ADS-2500We only)</i> on page 128 or <i>Scan Documents to a Shared Folder / Network Location (Windows®) (ADS-2500We only)</i> on page 134.
No Certificate (ADS-2500We only)	The certificate does not exist, or is corrupted.	Configure the settings under <b>Signed PDF</b> in the <b>Administrator</b> tab in Web Based Management. See <i>Scan Documents to an FTP Server (ADS-2500We only)</i> on page 128 or <i>Scan Documents to a Shared Folder / Network Location (Windows®) (ADS-2500We only)</i> on page 134.
Address Book Full / Address Full	The Address Book is full.	Delete unnecessary email addresses and then try again.
Registration Failed	(email Address) The email address is too long.	You can enter an email address that contains up to 64 characters.
	(Shortcut) The maximum number of email addresses in a shortcut has been reached.	Delete unnecessary email addresses and then try again.
Shortcuts Full	The maximum number of shortcuts has been reached.	Delete unnecessary shortcuts and then try again.
Cannot Delete	The email address is registered in a shortcut.	You cannot delete an email address used in a shortcut. Delete the shortcut first, and then try again.
Access Denied	Secure Function Lock is On.	Call your administrator to check your Secure Function Lock settings. See <i>User Restriction Functions</i> on page 21.

## Document Jam

Documents can jam in the ADF unit if they are not inserted or fed correctly or, if they are too long, or if multiple pages were fed at the same time (multifeed). Follow the steps below to clear a document jam.

- 1 Take out any paper from the ADF that is not jammed.
- 2 Open the Front Cover by pinching the Cover Release Lever ①.

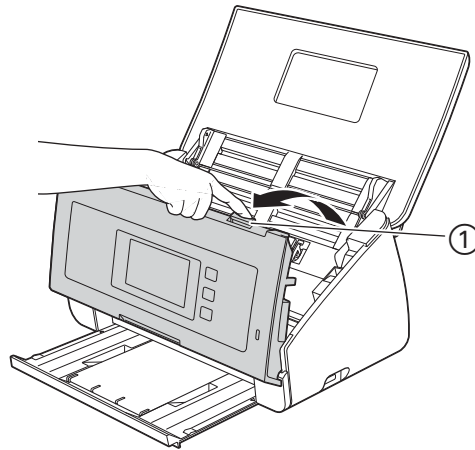

- 3 Pull the jammed document out of the machine.

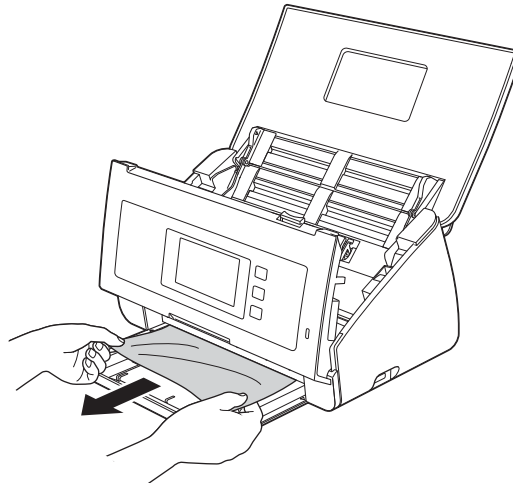

### NOTE

Check for ripped paper inside the machine. Remove any ripped paper you find inside the machine.

- 4 Close the Front Cover.
- 5 Press any button (ADS-2000e) or  (ADS-2500We).

### NOTE

When clearing the multifeed, confirm that the data scanned before the multifeed was detected has been saved, and then start scanning again at the next page or the beginning of the document.

## IMPORTANT

- Be careful when touching the Separation Pad and its surrounding area in the machine. Otherwise, you could cause serious damage to the machine.

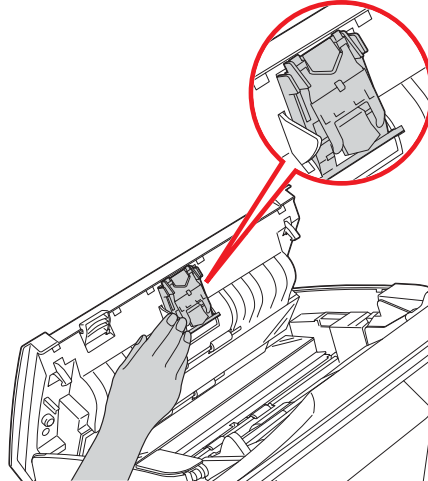

- To avoid damage to the jammed document, DO NOT pull the document out before opening the Front Cover.
- Take out any paper from the ADF before closing the Front Cover.
- To avoid future document jams, do the following:
  - Close the Front Cover properly by pushing it gently in the center.
  - Configure the settings for your document correctly.
  - Clean the Separation Pad and Pick-up Roller. To clean the Separation pad, see *Replace the Separation Pad* on page 183 for instructions on how to pull the Separation Pad out from the machine. Clean the rubber side of the Separation Pad with a soft lint-free cloth moistened with water, and then put the Separation Pad back into the machine. To clean the Pick-up Roller, see *Clean the Scanner* on page 173.
  - Stagger the pages and then load your document. See *Load Documents* on page 30.
  - Make sure your document is acceptable for the machine. See *Acceptable Documents* on page 24.
  - Load your document properly. See *Load Documents* on page 30.
  - Load no more than 50 pages at a time.
  - Load the card vertically when scanning cards.

## Long Paper Jam

---

Long paper refers to any paper over 11.69 inches (297 mm) but less than 34 inches (863 mm). To avoid a long paper jam, you must select **Long Paper** for **Scan Size** or **Document Size**.

- When you scan from your PC
  - *Change Scan Settings (ControlCenter4) (Windows®)* on page 67
  - *Change Scan Settings (ControlCenter2) (Macintosh)* on page 89
- When you scan from the machine (ADS-2500We)

Confirm the following settings on the LCD:

(Scan to USB/FTP/Network/email Server)

- 2-sided Scan: Off
- Scan Type: Color **or** Black and White
- Auto Deskew: Off
- Skip Blank Page: Off

(Scan to PC)

- 2-sided Scan: Off
- Auto Deskew: Off

# Troubleshooting

## IMPORTANT

For technical help, you must contact Brother customer support.

If you think there is a problem with your machine, check the chart below and follow the troubleshooting tips. Most problems can be easily resolved by yourself. If you need additional help, the Brother Solutions Center offers the latest FAQs and troubleshooting tips.

Visit us at <http://support.brother.com>

Using non-Brother supplies may affect the scan quality, hardware performance, and machine reliability.

## If you are having difficulty with your machine

### Scanning Difficulties

Difficulty	Cause	Suggestions
TWAIN or WIA errors appear when starting to scan. (Windows®)	TWAIN or WIA driver has not been chosen as the primary source in your scanning application.	Make sure the Brother TWAIN or WIA driver is chosen as the primary source in your scanning application. For example, in Nuance™ PaperPort™ 12SE, click <b>Scan Settings</b> and then <b>Select</b> to select the Brother TWAIN/WIA driver.
TWAIN errors appear when starting to scan. (Macintosh)	TWAIN driver has not been chosen as the primary source in your scanning application.	Make sure the Brother TWAIN driver is chosen as the primary source. In Presto! PageManager, click <b>File, Select Source</b> and select the Brother TWAIN driver. You can also scan documents using the ICA Scanner Driver.
OCR does not work.	<ul style="list-style-type: none"> <li>■ The scanner resolution is too low.</li> <li>■ (Macintosh users) Presto! PageManager has not been installed on your computer.</li> </ul>	<ul style="list-style-type: none"> <li>■ Increase the scanner resolution.</li> <li>■ (Macintosh users) Make sure you have installed Presto! PageManager on your computer. See <i>Installing Presto! PageManager</i> on page 109.</li> </ul>
Vertical lines are seen in the scanned image.	Paper dust has accumulated on the surface of the glass strips.	Clean the glass strips inside the machine. See <i>Clean the Scanner</i> on page 173.







Difficulty	Cause	Suggestions
The scanned image is missing.	<ul style="list-style-type: none"> <li>■ The Document Guides are not adjusted to fit the width of the document.</li> <li>■ The Auto Deskew feature was set to On when the document was scanned.</li> <li>■ The settings are not suitable for your document. For example, a Legal-size document was fed when Letter was selected as document size.</li> <li>■ The card was loaded horizontally.</li> </ul>	<ul style="list-style-type: none"> <li>■ Adjust the Document Guides to fit the width of the document. When Scan Size is set to Auto and you are scanning a document that contains multiple page sizes, insert narrow pages straight and as close to the center of the machine as possible. If the document does not stay straight while feeding, use Continuous Scanning.</li> <li>■ Set Auto Deskew to Off.</li> <li>■ Make sure the document size settings are suitable for your document.</li> <li>■ Load the card vertically.</li> </ul>
The scanned image is skewed.	<ul style="list-style-type: none"> <li>■ The Document Guides are not adjusted to fit the width of the document.</li> <li>■ The Auto Deskew feature was set to Off when the document was scanned.</li> </ul>	<ul style="list-style-type: none"> <li>■ Adjust the Document Guides to fit the width of the document. When Scan Size is set to Auto and you are scanning a document that contains multiple page sizes, insert narrow pages straight and as close to the center of the machine as possible. If the document does not stay straight while feeding, use Continuous Scanning.</li> <li>■ Set Auto Deskew to On.</li> </ul>
The scan speed is too slow.	The resolution is not suitable for your document.	Decrease the scanner resolution. Set scan size to a setting other than Auto.
The document was not fed.	<ul style="list-style-type: none"> <li>■ Paper dust has accumulated on the surface of the Pick-up Roller or Separation Pad.</li> <li>■ Too many documents are loaded in the ADF at a time.</li> <li>■ There are foreign objects in the ADF.</li> <li>■ Your document is too thin or too thick.</li> <li>■ Remote Setup is in process.</li> <li>■ Paper ejection has paused.</li> <li>■ The Separation Pad Cover is not properly closed.</li> </ul>	<ul style="list-style-type: none"> <li>■ Clean the Separation Pad and Pick-up Roller. To clean the Separation pad, see <i>Replace the Separation Pad</i> on page 183 to refer how to pull the Separation Pad out from the machine, clean the rubber side of the Separation Pad with a soft lint-free cloth moistened with water, and then attach the Separation Pad in the machine. To clean the Pick-up Roller, see <i>Clean the Scanner</i> on page 173.</li> <li>■ Make sure the maximum number of pages is suitable for your document. See <i>Acceptable Documents</i> on page 24.</li> <li>■ Remove any foreign objects or ripped paper from the ADF.</li> <li>■ Make sure your document is acceptable for the machine. See <i>Acceptable Documents</i> on page 24.</li> <li>■ Cancel Remote Setup.</li> <li>■ Finish ejecting the paper.</li> <li>■ Securely close the Separation Pad Cover until the hooks fit into the Front Cover.</li> </ul>

Difficulty	Cause	Suggestions
<p>The document is jammed.</p>	<ul style="list-style-type: none"> <li>■ Paper dust has accumulated on the surface of the Pick-up Roller or Separation Pad.</li> <li>■ There are foreign objects in the ADF.</li> <li>■ Your document is not acceptable for the machine.</li> </ul>	<ul style="list-style-type: none"> <li>■ Clean the Separation Pad and Pick-up Roller. To clean the Separation pad, see <i>Replace the Separation Pad</i> on page 183 to refer how to pull the Separation Pad out from the machine, clean the rubber side of the Separation Pad with a soft lint-free cloth moistened with water, and then attach the Separation Pad in the machine. To clean the Pick-up Roller, see <i>Clean the Scanner</i> on page 173.</li> <li>■ Remove any foreign objects or ripped paper from the ADF.</li> <li>■ Make sure your document is acceptable for the machine. See <i>Acceptable Documents</i> on page 24.</li> </ul>
<p>The scan quality is poor.</p>	<ul style="list-style-type: none"> <li>■ Paper dust has accumulated on the surface of the Pick-up Roller or Separation Pad.</li> <li>■ Paper dust has accumulated on the surface of the glass strips inside the machine.</li> <li>■ The resolution is too low.</li> </ul>	<ul style="list-style-type: none"> <li>■ Clean the Separation Pad and Pick-up Roller. To clean the Separation pad, see <i>Replace the Separation Pad</i> on page 183 to refer how to pull the Separation Pad out from the machine, clean the rubber side of the Separation Pad with a soft lint-free cloth moistened with water, and then attach the Separation Pad in the machine. To clean the Pick-up Roller, see <i>Clean the Scanner</i> on page 173.</li> <li>■ Clean the glass strips inside the machine. See <i>Clean the Scanner</i> on page 173.</li> <li>■ Increase the scanner resolution.</li> </ul>
<p>The machine pauses for about 3 seconds between each page when scanning.</p>	<p>The machine has entered motor save mode. If you scan continuously, the internal temperature of the machine may increase, causing the machine to enter motor save mode.</p> <p><b>NOTE</b></p> <p>The length of the pause may vary depending on the scanning conditions.</p>	<p>This is normal and you may continue to scan. If you scan continuously, the internal temperature of the machine may increase, causing the machine to enter motor save mode.</p>
<p>Bleed through is seen in the scan data.</p>	<p>The settings are not appropriate for the type of document being scanned.</p>	<p>Select the Bleed Through Prevention/Remove Background Color check box.</p>

Difficulty	Cause	Suggestions
Colors in the scanned data are dark.	The settings are not appropriate for the type of document being scanned.	Do one of the following: <ul style="list-style-type: none"> <li>■ Select the Bleed Through Prevention/Remove Background Color check box and then scan from your computer.</li> <li>■ Change Brightness higher and then scan from your computer.</li> <li>■ Change Contrast higher and then scan from your computer.</li> <li>■ Change Scan Type to Gray or Color and then scan from your computer.</li> </ul>
A page that is not a blank page is skipped.	<ul style="list-style-type: none"> <li>■ The document is too light.</li> <li>■ Skip Blank Page is set to On.</li> </ul>	Set Skip Blank Page to Off.
Cannot scan a long document.	Long Paper is not selected for the document size.	Select Long Paper for the document size. If you cannot select Long Paper, set both Auto Deskew and 2-sided Scanning to off. In addition, when scanning from the machine's Control Panel, set Skip Blank Page to off and set Scan Type to an option other than Auto. Then, you can select Long Paper for the document size. <ul style="list-style-type: none"> <li>■ <i>Long Paper Jam</i> on page 197</li> </ul>
Cannot set Auto Deskew to On when trying to scan using Scan to USB.	The document size is set to an option other than Auto.	Set the document size to Auto.
A multifeed occurs.	The document is not loaded properly.	Load your document properly (see <i>Standard-size Documents</i> on page 30), and then try again.
Cannot scan.	Secure Function Lock is on.	Call your administrator to check your secure function lock settings.  See <i>User Restriction Functions</i> on page 21

### Software Difficulties

Difficulty	Cause	Suggestions
Cannot install software.	—	(Windows® users only)  Run the <b>Repair MFL-Pro Suite</b> program on the DVD-ROM. This program will repair and reinstall the software.
Cannot find the Nuance serial number to install Nuance PDF Converter Professional 8.	—	(Windows® users only)  Enter the Nuance serial number that is shown on the “sleeve” of the MFL-Pro Suite DVD-ROM package when installing Nuance PDF Converter Professional 8.

Difficulty	Cause	Suggestions
Cannot find how to start ControlCenter4 (Windows®).	—	If the  icon is not displayed in the task tray, click  ( <b>Brother Utilities</b> ) on your desktop, and then click the drop-down list and select your model name (if not already selected). Click <b>SCAN</b> in the left navigation bar, and then click <b>ControlCenter4</b> .
Cannot start ControlCenter2 (Macintosh).	You have not logged in the computer as the administrator.	Restart the computer and log in as the administrator.
Cannot find how to start ControlCenter2 (Macintosh).	—	To start ControlCenter2, click the  (ControlCenter2) icon in the Dock. If the  (ControlCenter2) icon is not displayed in the Dock, in the <b>Finder</b> menu bar, click <b>Go &gt; Applications &gt; Brother</b> , and then double-click the  (ControlCenter2) icon. The  (ControlCenter2) icon appears in the Dock.
Cannot find how to configure the settings to scan from the Control Panel of the machine. (ADS-2000e only)	—	Use Remote Setup. See <i>Set Up the Brother Machine from Your Computer</i> on page 167.
Cannot change the settings by using Web Based Management. (ADS-2500We only)	Setting Lock is set to ON.	Set Setting Lock to Off. See <i>Turn Setting Lock On/Off</i> on page 20.
Cannot save the settings in Remote Setup or Web Based Management.	<ul style="list-style-type: none"> <li>■ The machine is processing.</li> <li>■ The machine is being configured from the machine's Control Panel.</li> </ul>	<ul style="list-style-type: none"> <li>■ Wait until the machine finishes processing and then try again.</li> <li>■ Stop configuring the machine from the Control Panel.</li> </ul>
Cannot start Remote Setup.	<ul style="list-style-type: none"> <li>■ The machine is turned off.</li> <li>■ The machine is not connected to your computer.</li> <li>■ The machine is in Sleep Mode.</li> <li>■ An error is occurring.</li> <li>■ The machine is scanning.</li> <li>■ The machine is being configured from the machine's Control Panel.</li> </ul>	<ul style="list-style-type: none"> <li>■ Turn on the machine and then try again.</li> <li>■ Connect the machine to your computer and then try again.</li> <li>■ Press any button (ADS-2000e) or  (ADS-2500We) or open the Top Cover, and then try again.</li> <li>■ Clear all errors and then try again.</li> <li>■ Wait until scanning has finished and try again.</li> <li>■ Stop configuring the machine from the Control Panel.</li> </ul>

## Network Difficulties (ADS-2500We only)

Difficulty	Suggestions
Cannot scan over the network.	Make sure that your machine is powered on and is online and in Ready Mode. Check the current network settings. See <i>Troubleshooting</i> in the Network User's Guide.
The network scanning feature does not work.	(Windows® users) It is necessary to configure the third-party Security/Firewall Software to allow Network scanning. To add port 54925 for Network scanning, enter the information below: In Name: Enter any description, for example Brother NetScan. In Port number: Enter 54925. In Protocol: UDP is selected. Refer to the instruction manual that came with your third-party Security/Firewall Software or contact the software manufacturer. (Macintosh users) Re-select your machine in the <b>Device Selector</b> application from the model list in ControlCenter2.
The Brother software cannot be installed.	(Windows® users) If the Security Software warning appears on the computer screen during the installation, change the Security Software settings to permit the Brother product setup program or other program to run. (Macintosh users) If you are using a firewall function of anti-spyware or antivirus security software, temporarily disable it and then install the Brother software.
Cannot connect to wireless network.	Check the wireless network settings.
Reset the network settings.	See <i>Reset the Machine (ADS-2500We only)</i> on page 206.

## Other Difficulties

Difficulty	Cause	Suggestions
The machine is in Sleep Mode (power save mode). (ADS-2500We only)	The machine is idle and the amount of time specified by the Sleep Time setting has elapsed.	Do one of the following: <ul style="list-style-type: none"> <li>■ Press .</li> <li>■ Open the Top Cover.</li> <li>■ Load your document.</li> </ul>
The machine is not turned on.	The machine was plugged in within 60 seconds after pulling out the plug.	Turn off the machine, wait 60 seconds, and then turn on the scanner.
The machine is in Offline Mode.	The machine is not connected to the computer.	Connect the machine to the computer and turn on the machine.

# Machine Information

## Check the Serial Number (ADS-2000e)

- 1 Start the ControlCenter application.
  - Windows®
    - 1 Click the  (ControlCenter4) icon in the task tray and then select **Open** from the menu. The **ControlCenter4** window appears.
    - 2 Click the **Device Settings** tab (the example below uses **Home Mode**).

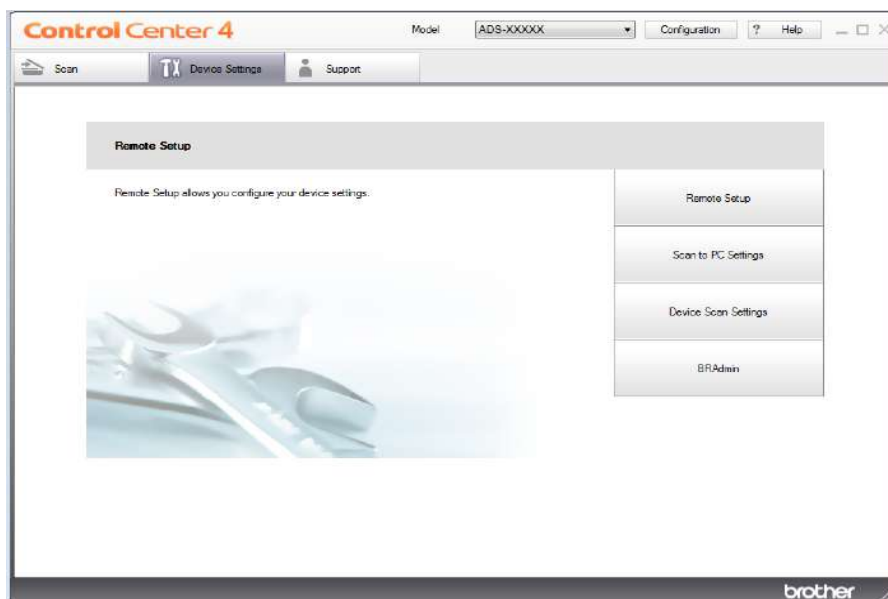

- Macintosh
  - 1 Click the  (ControlCenter2) icon in the Dock. The **ControlCenter2** window appears.

- 2 Click the **DEVICE SETTINGS** tab.



- 2 Click the **Remote Setup** button. The Remote Setup window appears.
- 3 Select **Machine Info.** in the folder tree. The window will display the **Serial Number** (the example below uses Windows®).

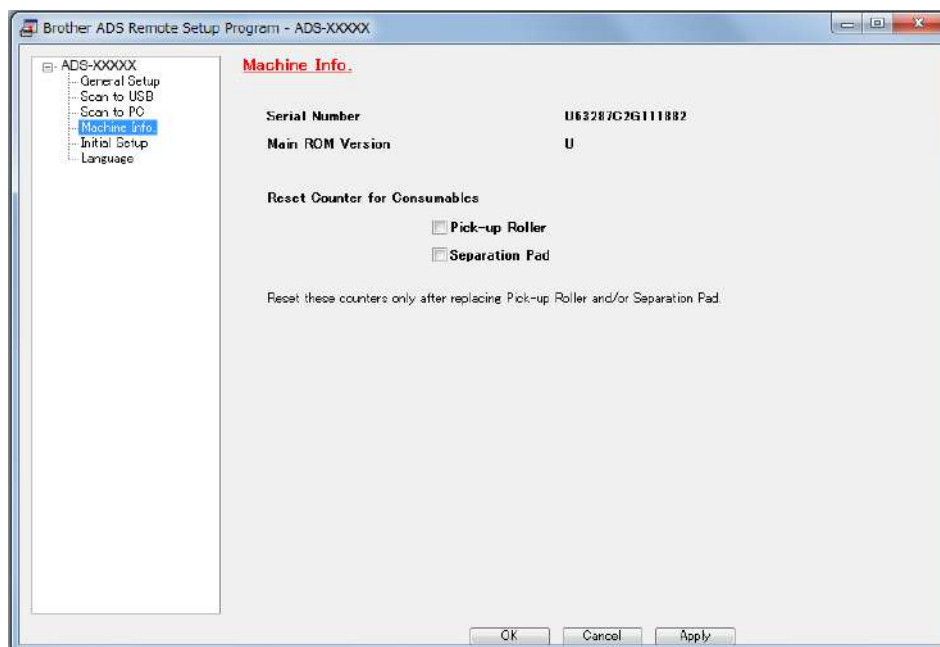

## Check the Serial Number (ADS-2500We)

- 1 On your scanner's LCD, press .
- 2 Press Machine Info.
- 3 Press Serial No. The LCD will display the machine's serial number.

## WLAN Enable/Disable (ADS-2500We only)

---

- 1 Press .
- 2 Press `Network`.
- 3 Press `WLAN`.
- 4 Press `▲` or `▼` to display `WLAN Enable`.
- 5 Press `WLAN Enable`.
- 6 Press `On` (or `Off`).

## Reset Functions

---

The following reset functions are available:

- Network (ADS-2500We only)

You can restore the network settings, such as the password and IP address information, to the factory settings.

- Address Book (ADS-2500We only)

You can reset the Address Book setting.

- All Settings

You can restore all settings to the factory settings.

Brother strongly recommends performing this procedure before transferring or disposing of the machine.

### NOTE

Unplug the interface cable before you choose `Network` or `All Settings`.

---

## Reset the Machine (ADS-2500We only)

---

- 1 Press .
- 2 Press `▲` or `▼` to display `Initial Setup`.
- 3 Press `Initial Setup` and then `Reset`.
- 4 Press the type of reset you want.
- 5 Press `Yes` to confirm.
- 6 Press `Yes` for two seconds to restart the machine.

## General

### NOTE

This chapter provides a summary of the machine's specifications. For additional specifications, visit <http://www.brother.com> for details.

(ADS-2000e)

<b>Memory Capacity</b>	<b>Standard</b>	256 MB
<b>Power Source</b>	<b>USA</b>	100 - 120 V AC 50/60 Hz
	<b>Latin American Countries</b>	220 - 240 V AC 50/60 Hz
<b>Power Consumption</b> <sup>2</sup>	<b>Scanning</b> <sup>3</sup>	Approx. 18 W
	<b>Ready</b> <sup>4</sup>	Approx. 1.5 W
	<b>Sleep</b>	Approx. 1.5 W
	<b>Power Down</b>	Approx. 0.3 W

(ADS-2500We)

<b>Memory Capacity</b>	<b>Standard</b>	256 MB
<b>Power Source</b>	<b>USA</b>	100 - 120 V AC 50/60 Hz
	<b>Latin American Countries</b>	220 - 240 V AC 50/60 Hz
<b>Touchscreen LCD (Liquid Crystal Display)</b>		Touchscreen 3.7 in. (93.4 mm) TFT Color LCD <sup>1</sup>
<b>Power Consumption</b> <sup>2</sup>	<b>Scanning</b> <sup>3</sup>	Approx. 20 W
	<b>Ready</b> <sup>4</sup>	Approx. 5.0 W
	<b>Sleep</b>	Approx. 2.0 W
	<b>Power Down</b>	Approx. 0.4 W

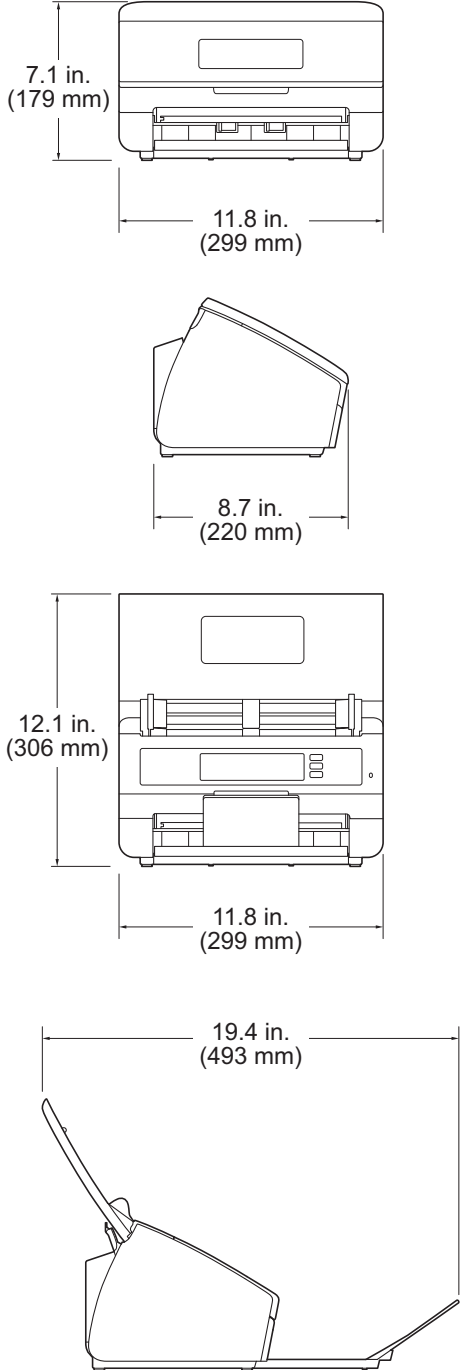
<p><b>Dimensions</b></p>		 <p>7.1 in. (179 mm)</p> <p>11.8 in. (299 mm)</p> <p>8.7 in. (220 mm)</p> <p>12.1 in. (306 mm)</p> <p>11.8 in. (299 mm)</p> <p>19.4 in. (493 mm)</p>
<p><b>Weights</b></p>		<p>Approx. 7.3 lb (3.3 kg) (ADS-2000e)                  Approx. 7.9 lb (3.6 kg) (ADS-2500We)</p>
<p><b>Temperature</b></p>	<p><b>Operating</b></p>	<p>41 to 95 °F (5 to 35 °C)</p>
<p><b>Humidity</b></p>	<p><b>Operating</b></p>	<p>20 to 80%</p>
<p><b>ADF (automatic document feeder)</b></p>		<p>Up to 50 pages (Paper: 20 lb (80 g/m<sup>2</sup>) Legal size, or less than 0.2 in. (5 mm))</p>

<b>Document Size</b>	<b>Multiple Paper</b>	<b>Width</b>	2.0 to 8.5 in. (51 to 215.9 mm)
		<b>Length</b>	2.76 to 14 in. (70 to 355.6 mm)
	<b>Single Paper</b>	<b>Width</b>	2.0 to 8.5 in. (51 to 215.9 mm)
		<b>Length</b>	2.76 to 34.0 in. (70 to 863 mm)

<sup>1</sup> Measured diagonally.

<sup>2</sup> Measured when the machine is connected to your computer.

<sup>3</sup> When 2-sided (duplex) scanning.

<sup>4</sup> When all network ports activated and connected.

## Scanner

<b>Color/Black</b>		Yes/Yes
<b>TWAIN Compliant</b>	<b>Windows®</b>	Windows® XP <sup>1</sup> /Windows Vista®/Windows® 7/Windows® 8/Windows® 8.1
	<b>Macintosh</b>	OS X v10.7.5, 10.8.x, 10.9.x <sup>2</sup>
<b>WIA Compliant</b>	<b>Windows®</b>	Windows® XP <sup>1</sup> /Windows Vista®/Windows® 7/Windows® 8/Windows® 8.1
<b>ICA Compliant</b>	<b>Macintosh</b>	OS X v10.7.5, 10.8.x, 10.9.x <sup>2</sup>
<b>ISIS™ Compliant</b>	<b>Windows®</b>	Windows® XP <sup>1</sup> /Windows Vista®/Windows® 7/Windows® 8/Windows® 8.1
<b>Color Depth</b>	<b>Input</b>	30 bit color Processing
	<b>Output</b>	24 bit color Processing
<b>Resolution</b>	<b>Interpolated</b>	Up to 1,200 × 1,200 dpi
	<b>Optical</b>	Up to 600 × 600 dpi
<b>Scanning Width</b>		Up to 8.34 in. (212 mm)
<b>Greyscale</b>		256 levels
<b>Max. Speed</b>		For detailed specifications, visit <a href="http://www.brother.com">http://www.brother.com</a>

<sup>1</sup> Windows® XP in this User's Guide includes Windows® XP Home Edition and Windows® XP Professional.

<sup>2</sup> For the latest driver updates for the OS X you are using, visit us at <http://support.brother.com>

## Direct Scan Feature (Scan to USB)

<b>Compatible Media</b>	USB flash drive <sup>1</sup>
<b>Interface</b>	Interface USB 2.0 Full Speed

<sup>1</sup> USB Mass Storage standard up to 32 GB  
Support format: FAT12/FAT16/FAT32/exFAT.

## Interfaces

<b>USB</b>	Hi-Speed USB 2.0 <sup>1, 2</sup> Use a USB 2.0 cable (Type A/B) that is no more than 6 feet (2.0 meters) long.
<b>LAN</b> <sup>3</sup> (ADS-2500We only)	Use an Ethernet UTP cable category 5 or later.
<b>Wireless LAN</b> (ADS-2500We only)	IEEE 802.11b/g/n (Infrastructure/Ad-hoc Mode)

<sup>1</sup> Your machine has a Hi-Speed USB 2.0 interface. The machine can also be connected to a computer that has a USB 1.1 interface.

<sup>2</sup> Third party USB ports are not supported.

<sup>3</sup> See *Network (ADS-2500We only)* on page 210.  
See *Supported Protocols and Security Features* in the Network User's Guide.

## Network (ADS-2500We only)

### NOTE

For more information about the Network specifications, see the Network User's Guide.

<b>LAN</b>	You can connect your machine to a network for Network Scanning and Remote Setup. Also included is Brother BRAdmin Light <sup>1</sup> Network Management software.	
<b>Wireless Network Security</b>	SSID (32 chr), WEP 64/128 bit, WPA-PSK (TKIP/AES), WPA2-PSK (AES), 802.1x (LEAP, EAP-FAST, PEAP, EAP-TLS, EAP-TTLS)	
<b>Setup Support Utility</b>	<b>AOSS</b> ™	Yes
	<b>WPS</b>	Yes

<sup>1</sup> (Windows® only) If you require more advanced scanner management, use the latest Brother BRAdmin Professional utility version that is available as a download from <http://support.brother.com>

# Computer Requirements

SUPPORTED OPERATING SYSTEMS AND SOFTWARE FUNCTIONS								
Computer Platform & Operating System Version		Supported PC Software Functions	PC Interface	Processor Minimum Speed	Minimum RAM	Recommended RAM	Hard Disk Space to install	
							For Drivers	For Applications
Windows® Operating System	Windows® XP Home (SP2 or later) <sup>2</sup>	Scanning	USB 10/100Base-TX (Ethernet) Wireless <sup>3</sup> 802.11b/g/n	Intel® Pentium® II or equivalent	128 MB	256 MB	150 MB	1.0 GB
	Windows® XP Professional (SP2 or later) <sup>2</sup>			Intel® Pentium® 4 or equivalent 64-bit (Intel® 64 or AMD64) supported CPU	512 MB	1 GB	500 MB	1.0 GB
	Windows® Vista® <sup>2</sup>				1 GB (32 bit) 2 GB (64 bit)	1 GB (32 bit) 2 GB (64 bit)	650 MB	1.0 GB
	Windows® 7 <sup>2</sup> Windows® 8 <sup>2</sup> Windows® 8.1 <sup>2</sup>							
Macintosh Operating System	OS X v10.7.5 OS X v10.8.x OS X v10.9.x	Scanning	USB <sup>1</sup> 10/100Base-TX (Ethernet) Wireless <sup>3</sup> 802.11b/g/n	Intel® Processor	2 GB	2 GB	80 MB	1.0 GB
<p>Conditions:</p> <p><sup>1</sup> Third party USB ports are not supported.</p> <p><sup>2</sup> Nuance™ PaperPort™ 12SE supports Windows® XP Home (SP3 or later), Windows® XP Professional (SP3 or later), Windows Vista® (SP2 or later), Windows® 7, Windows® 8 and Windows® 8.1.</p> <p><sup>3</sup> ADS-2500We only.</p> <p>For the latest driver updates, visit us at (in USA) <a href="http://www.brother.com">www.brother.com</a> (in Canada) <a href="http://www.brother.ca">www.brother.ca</a></p> <p>All trademarks, brand and product names are the property of their respective companies.</p>								



# B



## Appendix

### Entering Text (ADS-2500We only)

When you need to enter text into the machine the keyboard appears on the Touchscreen.



#### NOTE

- To change between lowercase or uppercase, press .
- To toggle between the keyboards (letters, numbers, or symbols), press .



#### Inserting spaces



To enter a space, press *Space*. Or, you can press  to move the cursor.

#### NOTE

The characters that are available may differ depending on your country.



#### Making corrections

If you entered an incorrect character and want to change it, press  to move the cursor to highlight the incorrect character, and then press . Enter the correct character. You can also back up and insert letters.

Press  for each character you want to erase, or press and hold  to erase all the characters.

## LED Indications (ADS-2000e only)

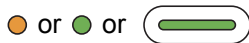
The LED indications shown in the table below are used in the illustrations in this chapter.

	The LED is off.
	The LED is on.
	The LED is blinking.

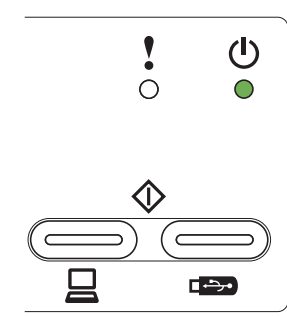
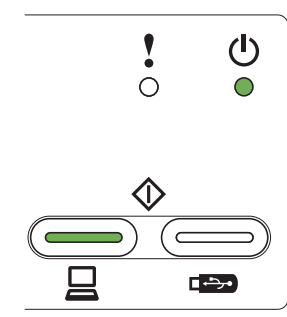
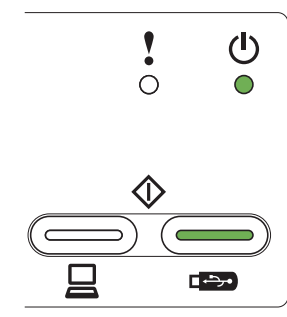
LEDs	Machine Status
	<p><b>Ready</b></p> <p>The machine is ready to scan.</p>
	<p><b>Ready (PC connected)</b></p> <p>The machine is ready to scan and connected to your computer.</p>
	<p><b>Ready (USB connected)</b></p> <p>The machine is ready to scan and connected to a USB device.</p>

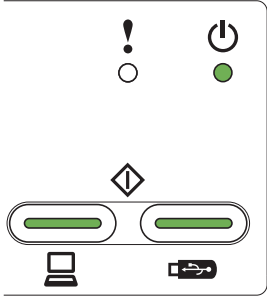
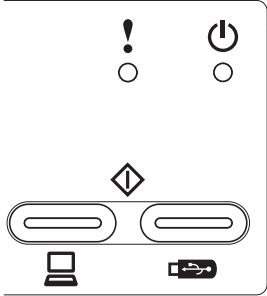
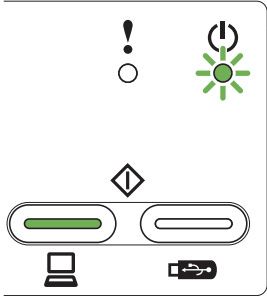
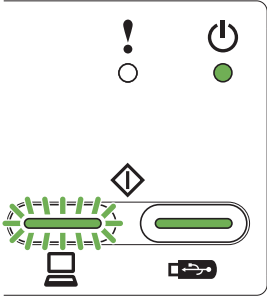
LEDs	Machine Status
	<p><b>Ready (PC and USB connected)</b></p> <p>The machine is ready to scan and connected to your computer and a USB device.</p>
	<p><b>Sleep</b></p> <p>The machine is in Sleep Mode. The machine acts as though it is turned off. Do one of the following to wake up the machine:</p> <ul style="list-style-type: none"> <li>■ Press any key.</li> <li>■ Open the Top Cover.</li> <li>■ Load your document.</li> </ul> <p>The machine will enter Ready Mode.</p>
	<p><b>Remote Setup</b></p> <p>Remote Setup is in process. To cancel Remote Setup, click the Cancel button in the Remote Setup window on your computer.</p>
	<p><b>Scanning to PC</b></p> <p>Scan to your computer is in process.</p> <p><b>NOTE</b></p> <p>The <b>Scan to USB</b> LED lights up when the USB flash drive is connected to the machine.</p>

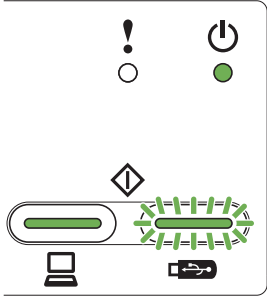
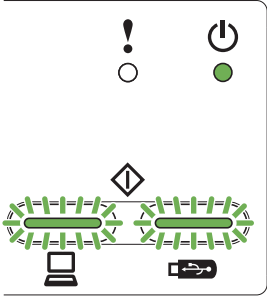
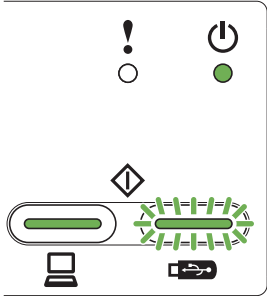
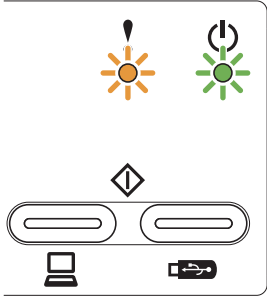
LEDs	Machine Status
	<p><b>Scanning to USB</b> Scan to your USB device is in process.</p> <p><b>NOTE</b> The <b>Scan to PC</b> LED lights up when your computer is connected to the machine.</p>
	<p><b>Ejecting Paper</b> The machine is ejecting paper. If there is no document loaded in the ADF or the paper ejection was temporarily stopped, press the Stop button to finish ejecting the paper.</p>
	<p><b>Checking Device</b> The machine is checking the connected USB device.</p> <p><b>NOTE</b> The <b>Scan to PC</b> LED lights up when your computer is connected to the machine.</p>
	<p><b>Downloading Firmware</b> The machine is downloading the latest firmware.</p>

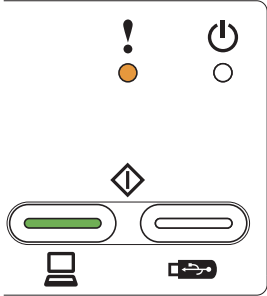
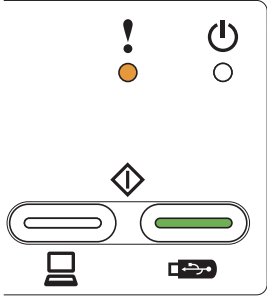
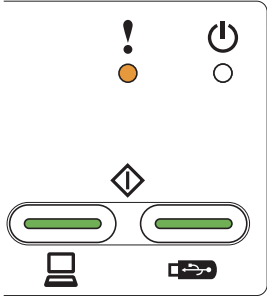
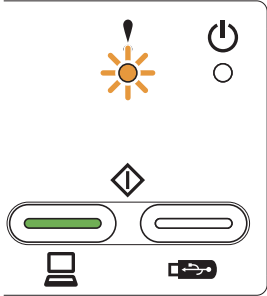
LEDs	Machine Status
	<p><b>Replace Separation Pad</b></p> <p>Replace the Separation Pad with a new one. See <i>Replace the Separation Pad</i> on page 183.</p>
	<p><b>Replace Pick-up Roller</b></p> <p>Replace the Pick-up Roller with a new one. See <i>Replace the Pick-up Roller</i> on page 185.</p>
	<p><b>Replace Separation Pad and Pick-up Roller</b></p> <p>Replace the Separation Pad and the Pick-up Roller with new ones. See <i>Replace the Separation Pad</i> on page 183 and <i>Replace the Pick-up Roller</i> on page 185.</p>
	<p><b>Front Cover is Open</b></p> <p>Close the Front Cover of the machine.</p>

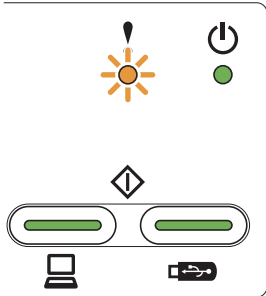
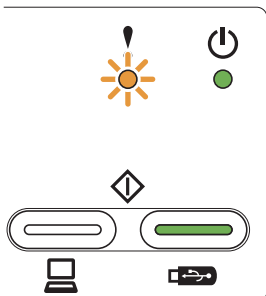
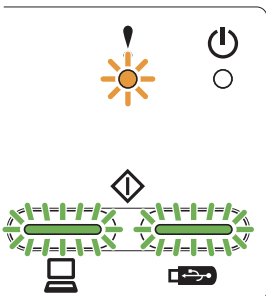
LEDs	Machine Status
	<p><b>Document Jam</b></p> <p>Clear the document jam (see <i>Document Jam</i> on page 195) and then do the following:</p> <ul style="list-style-type: none"> <li>■ Load the card vertically when scanning cards.</li> <li>■ Select <b>Long Paper (Normal Width)</b> or <b>Long Paper (Narrow Width)</b> from the <b>Scan Size</b> or <b>Document Size</b> drop-down list when scanning a long document.</li> </ul> <p>You can select <b>Long Paper</b> when you configure the settings as following:</p> <ul style="list-style-type: none"> <li>• <b>Auto Deskew:</b> Off</li> <li>• <b>2-sided Scanning:</b> Off</li> </ul> <p>To change the settings, do one of the following:</p> <ul style="list-style-type: none"> <li>■ See <i>Change Scan Settings (ControlCenter4) (Windows®)</i> on page 67.</li> <li>■ See <i>Change Scan Settings (ControlCenter2) (Macintosh)</i> on page 89.</li> <li>■ See <i>Change Scan to PC Settings (Windows®)</i> on page 147.</li> <li>■ See <i>Change Scan to PC Settings (Macintosh)</i> on page 154.</li> </ul>
	<p><b>Out of Memory</b></p> <p>The machine memory is full and the machine cannot scan the entire document. To clear the error, do one of the following:</p> <ul style="list-style-type: none"> <li>■ Press any button.</li> <li>■ Turn the machine off and then on by unplugging the machine from the AC power outlet and then plugging the machine in again.</li> </ul> <p>To prevent the error, do one of the following:</p> <ul style="list-style-type: none"> <li>■ Reduce the numbers of your documents.</li> <li>■ Set resolution setting or file size smaller.</li> </ul>
	<p><b>Unusable Device</b></p> <p>Disconnect the unusable device from the USB port. Turn the machine off and then on by unplugging the power cord from the AC power outlet and then plugging it back in again.</p>

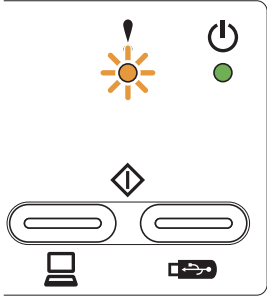
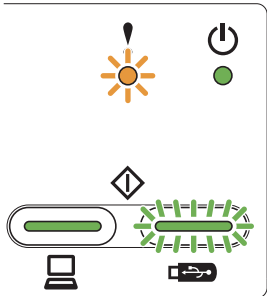
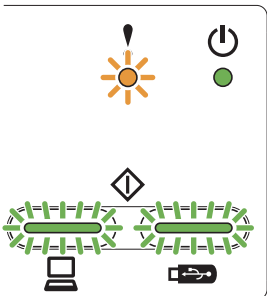
LEDs	Machine Status
	<p><b>Multifeed Detection</b></p> <p>Multiple pages were fed at the same time. Clear the Multifeed. See <i>Document Jam</i> on page 195):</p> <ul style="list-style-type: none"> <li>■ Clear the <b>Multifeed Detection</b> check box when scanning business cards.</li> <li>■ Select the <b>Plastic Card Mode</b> check box when scanning a plastic card.</li> <li>■ Select the <b>Carrier Sheet Mode</b> check box when scanning using the Carrier Sheet.</li> </ul> <p>To change the settings, do one of the following:</p> <ul style="list-style-type: none"> <li>■ See <i>Change Scan Settings (ControlCenter4) (Windows®)</i> on page 67.</li> <li>■ See <i>Change Scan Settings (ControlCenter2) (Macintosh)</i> on page 89.</li> <li>■ See <i>Change Scan to PC Settings (Windows®)</i> on page 147.</li> <li>■ See <i>Change Scan to PC Settings (Macintosh)</i> on page 154.</li> </ul> <p>Confirm that the data scanned before the multifeed occurred has been saved, and start scanning again from the next page or from the beginning.</p> <p><b>NOTE</b></p> <p>The data scanned before the multifeed occurred is not saved when scanning using the <b>Scan to USB</b> key on the control panel unless the file type is JPEG.</p>
	<p><b>Unusable USB Device</b></p> <p>Remove the unsupported USB device such as a mobile device, which does not support USB flash drive mode, from the USB port.</p>
	<p><b>USB Hub is Not Supported</b></p> <p>A Hub or USB Flash drive with a Hub is inserted in the USB port. Remove any unsupported devices, such as a USB hub or a USB flash drive that contains a hub.</p>

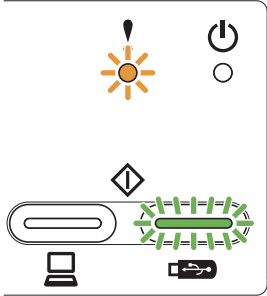
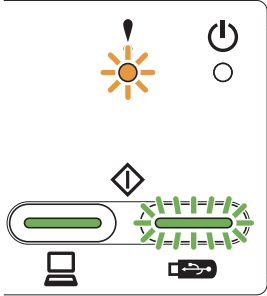
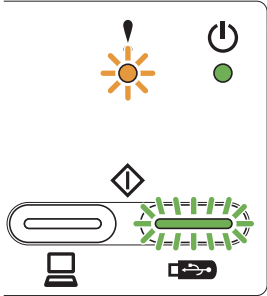
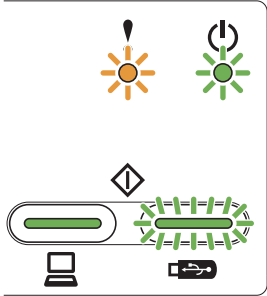
LEDs	Machine Status
	<p><b>Storage Full</b></p> <p>The inserted USB flash drive is full. Press any button and then do one of the following:</p> <ul style="list-style-type: none"> <li>■ Delete unused files or folders from the USB flash drive and then try again.</li> <li>■ Use a USB flash drive that has available space.</li> </ul>
	<p><b>Access Error</b></p> <p>The USB flash drive was removed when being accessed. Press any button.</p>
	<p><b>Protected Device</b></p> <p>The inserted USB flash drive is write-protected. Remove the protected USB flash drive, press any button and then do one of the following:</p> <ul style="list-style-type: none"> <li>■ Turn off the USB flash drive's write-protection and then try again.</li> <li>■ Use a USB flash drive that has write-protection turned off.</li> </ul>
	<p><b>Too Many Files</b></p> <p>Your machine cannot save to a USB flash drive if it contains too many files. Remove the USB flash drive, press any key and then do one of the following:</p> <ul style="list-style-type: none"> <li>■ Delete unused files or folders from the root folder of the USB flash drive and then try again.</li> <li>■ Use a USB flash drive that contains fewer than 999 files.</li> </ul>

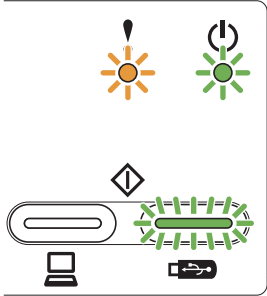
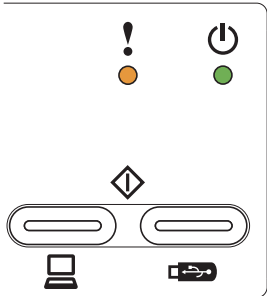
LEDs	Machine Status
	<p><b>File Name Cannot Be Used</b></p> <p>The maximum sequential number for the file name has been reached. Press any button and then do one of the following:</p> <ul style="list-style-type: none"> <li>■ Delete unused files from the USB flash drive and then try again.</li> <li>■ Change the file name by doing one of the following: <ul style="list-style-type: none"> <li>• See <i>Change Scan Settings (ControlCenter4) (Windows®)</i> on page 67.</li> <li>• See <i>Change Scan Settings (ControlCenter2) (Macintosh)</i> on page 89.</li> <li>• See <i>Change Scan to PC Settings (Windows®)</i> on page 147.</li> <li>• See <i>Change Scan to PC Settings (Macintosh)</i> on page 154.</li> <li>• See <i>Save Scanned Documents on a USB Flash Drive</i> on page 123.</li> </ul> </li> </ul>
	<p><b>All Blank Page Skipped</b></p> <p>All scanned pages were skipped as blank pages. Press any button and then do one of the following:</p> <ul style="list-style-type: none"> <li>■ Place your document, <b>face down, top edge first</b> in the ADF.</li> <li>■ Set Blank Page Skip to off by doing one of the following: <ul style="list-style-type: none"> <li>• See <i>Change Scan Settings (ControlCenter4) (Windows®)</i> on page 67.</li> <li>• See <i>Change Scan Settings (ControlCenter2) (Macintosh)</i> on page 89.</li> <li>• See <i>Change Scan to PC Settings (Windows®)</i> on page 147.</li> <li>• See <i>Change Scan to PC Settings (Macintosh)</i> on page 154.</li> </ul> </li> </ul>

## Service Call Indications

If there is an error that cannot be cleared by the user, the machine will indicate that a service call is needed by lighting up all the LEDs as shown below.

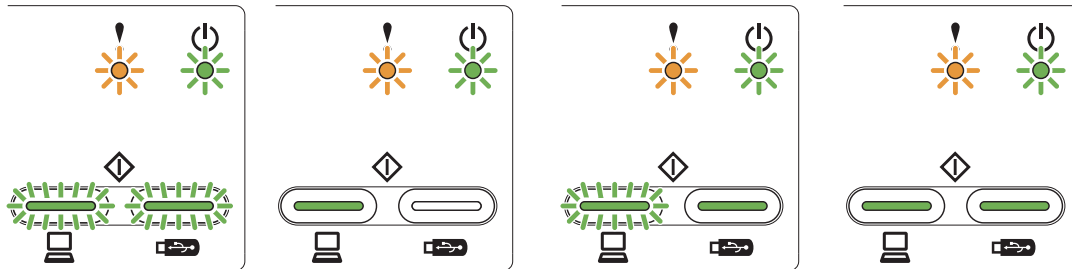

If you see the service call indication shown above, turn the machine off and then on, and then try to scan again.

If the error has not cleared after turning the machine off and then on, press **Scan to PC** and then **Scan to USB**. The LEDs will light up as shown in the table below to identify the error.

### LED Error Indication

Error Code		Error Indicator	Power Indicator	Scan to PC LED	Scan to USB LED
0xA7	Scan to PC <sup>1</sup>	○	○		
	Scan to USB <sup>2</sup>	○	●		
0xA9	Scan to PC <sup>1</sup>	○	○		
	Scan to USB <sup>2</sup>	○	●		
0xE6	Scan to PC <sup>1</sup>	○	●		
	Scan to USB <sup>2</sup>	○	○		

<sup>1</sup> When pressing the **Scan to PC** key, the LEDs will light up as shown in the table above.

<sup>2</sup> When pressing the **Scan to USB** key, the LEDs will light up as shown in the table above.

For example, the LED indication below indicates the error code 0xA7.

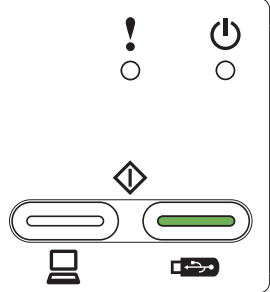
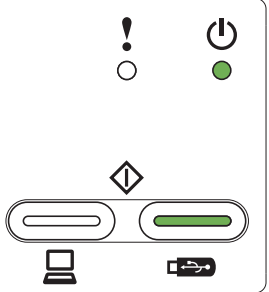
When pressing the <b>Scan to PC</b> key	When pressing the <b>Scan to USB</b> key
 The diagram shows a control panel with two buttons: 'Scan to PC' (with a laptop icon) and 'Scan to USB' (with a USB icon). Above the buttons is a diamond-shaped indicator. At the top are two LEDs: an error LED (with an exclamation mark icon) and a power LED (with a power icon). In this state, the error LED is lit green and the power LED is unlit.	 The diagram shows the same control panel. In this state, the error LED is unlit and the power LED is lit green.

Make a note of the error code, referring to the table above, and report the code to your dealer or to Brother Customer Service.

# C

# Index

## B

Brother	
Brother Numbers .....	i
Customer Service .....	ii
FAQs (Frequently Asked Questions) .....	i
Product Support .....	ii
Solutions Center .....	i

## C

ControlCenter2	
Macintosh .....	154, 164
ControlCenter4	
Windows® .....	46, 147

## D

Device Selector .....	43, 170
Drivers	
Macintosh	
ICA .....	114
TWAIN .....	109
Windows®	
TWAIN .....	96
WIA .....	96

## L

LCD (Liquid Crystal Display)	
Brightness .....	14
Dim Timer .....	14

## M

Memory Storage .....	15
----------------------	----

## N

Nuance™ PaperPort™ 12SE (Windows®) .....	96
--	----

## P

Power Failure .....	15
Presto! PageManager (Macintosh) .....	109

## R

Remote Setup .....	167
--------------------	-----

## S

Scan	
Macintosh	
ICA Compliant .....	114
Presto! PageManager .....	109
TWAIN Compliant .....	109
Windows®	
Nuance™ PaperPort™ 12SE .....	96
TWAIN Compliant .....	96
WIA Compliant .....	96
Sleep Mode .....	16
Status Monitor	
Macintosh .....	164
Windows® .....	162

## T

Text, entering .....	212
Troubleshooting .....	198

## V

Volume, Setting	
Beeper .....	15

## W

Web Connect .....	iii
-------------------	-----

# brother

**Visit us on the World Wide Web**  
**<http://www.brother.com>**

These machines are approved for use in the country of purchase only. Local Brother companies or their dealers will only support machines purchased in their own countries.



[www.brotherearth.com](http://www.brotherearth.com)