

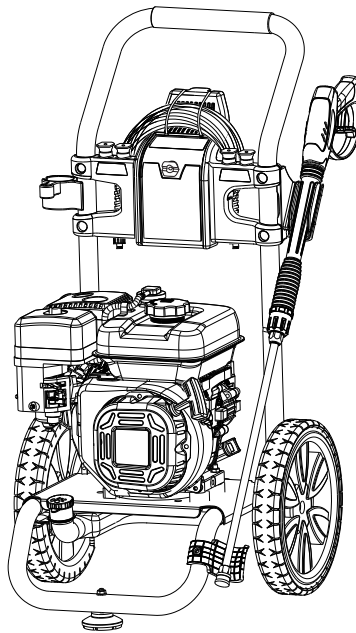

3100 PSI PRESSURE WASHER



Model # PW31
bit.ly/WENvideo

IMPORTANT:

Your new tool has been engineered and manufactured to WEN's highest standards for dependability, ease of operation, and operator safety. When properly cared for, this product will supply you years of rugged, trouble-free performance. Pay close attention to the rules for safe operation, warnings, and cautions. If you use your tool properly and for intended purpose, you will enjoy years of safe, reliable service.

NEED HELP? CONTACT US!

Have product questions? Need technical support?
Please feel free to contact us at:



800-232-1195 (M-F 8AM-5PM CST)



techsupport@wenproducts.com



WENPRODUCTS.COM



TABLE OF CONTENTS

Pressure Washer Identification	3
Service Record	3
Introduction	4
Safety Information	4
General Safety Procedures	5
Important Safety Instructions	6
Pressure washer Components	7
Pressure washer Preperation	8
Operation	12
Maintenance & Care	15
Storage & Transport	19
Specifications	20
Troubleshooting	21
Exploded View and Parts List	22
Warranty Statement	26

For video instructions on setting up
your pressure washer, visit:
<http://bit.ly/wenPW31>

PRESSURE WASHER IDENTIFICATION

If assistance for information or service is required, please contact the Customer Service Help Line by calling 800-232-1195; customer will be asked to provide pressure washer information when calling.

Refer to the illustration below for the location of the serial number. Record pressure washer information in the spaces provided below.

DATE OF PURCHASE: _____

PURCHASED FROM: _____

PRESSURE WASHER SERIAL NUMBER: _____

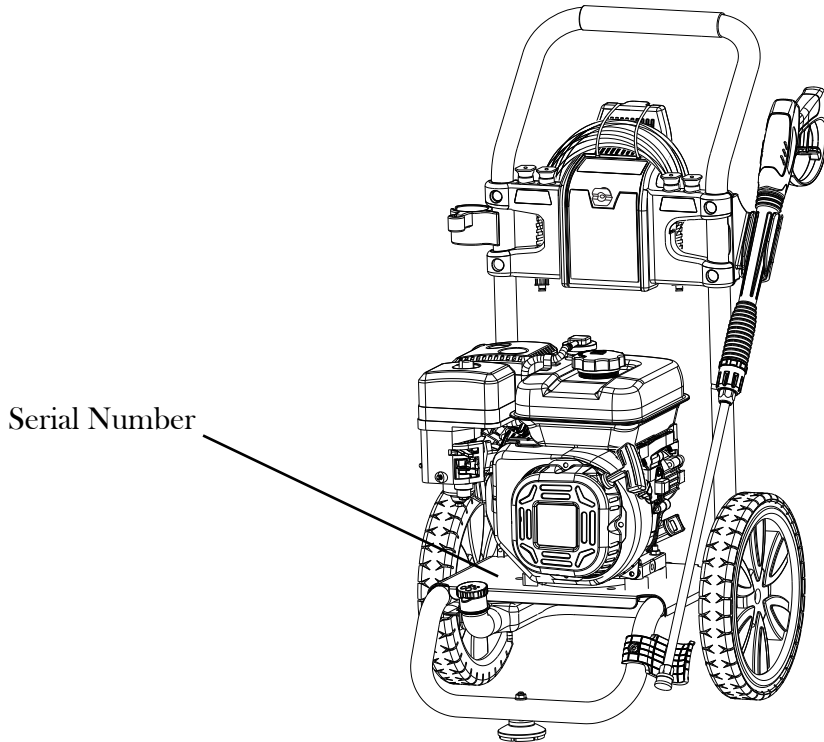

SERVICE RECORD

Record Service Dates:

	Date	Date	Date	Date	Date	Date
Change Oil						
Change Spark Plug						
Clean Fuel Tank						
Clean Air Cleaner						

INTRODUCTION

Thank You for Purchasing a WEN® Pressure Washer. This manual provides information regarding the safe operation and maintenance of this product. Every effort has been made to ensure the accuracy of the information in this manual. WEN® reserves the right to change this product and specifications at any time without prior notice.

Please keep this manual available to all users during the entire life of the pressure washer.



This manual contains special messages to bring attention to potential safety concerns, pressure washer damage as well as helpful operating and servicing information. Please read all the information carefully to avoid injury and machine damage.

QUESTIONS? PROBLEMS?

In order to answer questions and solve problems in the most efficient and speedy manner, contact Customer Service at (800) 232-1195, M-F 8-5 CST

NOTICE REGARDING EMISSIONS

Engines that are certified to comply with U.S. EPA emission regulations for SORE (Small Off Road Equipment), are certified to operate on regular unleaded gasoline, and may include the following emission control systems: (EM) Engine Modifications and (TWC) Three-Way Catalyst (if so equipped).

SAFETY INFORMATION

Before operating this pressure washer read and observe all warnings, cautions, and instructions on the pressure washer and in this Owner's Manual.

NOTE: The following safety information is not meant to cover all possible conditions and situations that may occur. Read the entire Owner's Manual for safety and operating instructions. Failure to follow instructions and safety information could result in serious injury or death.

This safety alert symbol is used to identify safety information about hazards that can result in personal injury.



A signal word (**DANGER**, **WARNING**, or **CAUTION**) is used with the alert symbol to indicate the likelihood and the potential severity of injury. In addition, a hazard symbol may be used to represent the type of hazard.

DANGER indicates a hazard, which, if not avoided, will result in death or serious injury.

WARNING indicates a hazard, which, if not avoided, could result in death or serious injury.

CAUTION indicates a hazard, which, if not avoided, might result in minor or moderate injury.

CAUTION when used without the alert symbol, indicates a situation that could result in damage to the engine or pressure washer.

GENERAL SAFETY PROCEDURES

For any questions regarding the hazard and safety notices listed in this manual or on the product, please call (800)-232-1195 M-F 8-5 CST before using the pressure washer.

DANGER: CARBON MONOXIDE

Using a pressure washer indoors **CAN KILL YOU IN MINUTES**. Pressure washer exhaust contains carbon monoxide (CO). This is a poison gas you cannot see or smell. If you can smell the pressure washer exhaust, you are breathing CO. But even if you cannot smell the exhaust, you could be breathing CO.

NEVER use a pressure washer inside homes, garages, crawlspaces, or other partly enclosed areas. Deadly levels of carbon monoxide can build up in these areas. Using a fan or opening windows and doors does **NOT** supply enough fresh air. **ONLY** use a pressure washer outside and far away from windows, doors, and vents. These openings can pull in pressure washer exhaust.

Even if you use a pressure washer correctly, CO may leak into the home. **ALWAYS** use a battery-powered or battery-backup CO alarm in the home. If you start to feel sick, dizzy, or weak after the pressure washer has been running, move to fresh air **RIGHT AWAY**. See a doctor. You may have carbon monoxide poisoning.



WARNING: The exhaust from this product contains chemicals known to the State of California to cause cancer, birth defects, or other reproductive harm.



WARNING: This pressure washer may emit highly flammable and explosive gasoline vapors, which can cause severe burns or even death if ignited. A nearby open flame can lead to explosion even if it isn't directly in contact with gasoline.

- Do not operate near open flame.
- Do not smoke near pressure washer.
- Always operate on a firm, level surface.
- Always turn pressure washer off before refueling. Allow pressure washer to cool for at least 2 minutes before removing fuel cap. Loosen cap slowly to relieve pressure in tank.
- Do not overfill fuel tank. Gasoline may expand during operation. Do not fill to the top of the tank. Allow for expansion.
- Always check for spilled fuel before operating.
- Empty fuel tank before storing or transporting the pressure washer.
- **ALWAYS** ground the pressure washer before using it (see the "Ground the Pressure washer" portion of the "Pressure washer Preparation" section).
- Do not allow children or non-qualified persons to operate.

GENERAL SAFETY PROCEDURES



WARNING: This pressure washer produces heat when running. Temperatures near exhaust can exceed 150° F (65° C).

Do not touch hot surfaces. Pay attention to warning labels on the pressure washer identifying hot parts of the machine.

Allow pressure washer to cool down after use before touching the engine or areas of the pressure washer that become hot during operation.

CAUTION: Misuse of this pressure washer can damage it and shorten its life.

Only use the pressure washer for its intended purposes.

Turn the engine switch to “OFF” position when the engine is not running.

The high pressure stream of water can cut through skin and cause serious injury. Do not aim the stream of water at yourself or at any one else, including animals.

Hoses and tubes can become damaged from coming in contact with a hot engine or muffler. Always double check the hose for perforations before starting up the machine and keep it clear of the engine and the muffler.

Kickback from operation can cause the user to fall down. Always operate the pressure washer on a level and non-elevated surface to prevent the risk of falling.

Always wear safety goggles to protect from possible mishaps with the stream or detergents. Always be aware of the dangers associated with the detergents and chemicals that you are working with.

Attach all hoses before starting the engine.

SAVE THESE INSTRUCTIONS - This manual contains important instructions for the WEN® Pressure Washer that should be followed during installation and maintenance of the pressure washer.

Pressure washers vibrate in normal use. During and after the use of the pressure washer, inspect both the pressure washer as well as extension and power supply cords for damage resulting from vibration. Have damaged items repaired or replaced as necessary. Do not use plugs or cords that show signs of damage such as broken or cracked insulation or damaged blades.

PRESSURE WASHER COMPONENTS

Use the illustrations below to become familiar with the locations and functions of the various components and controls of this pressure washer.

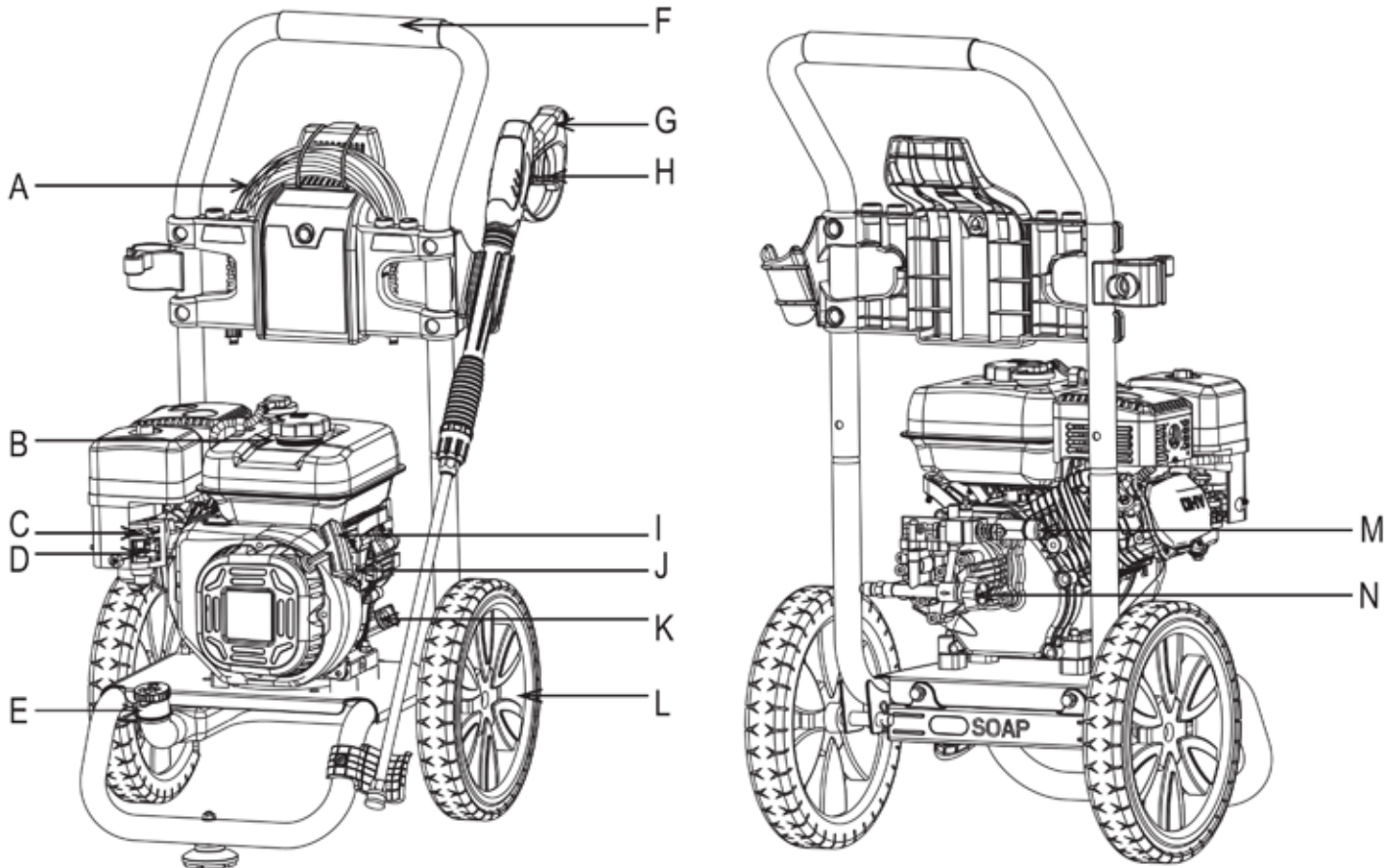

- A 30' High Pressure Hose
- B Fuel Tank and Cap
- C Choke Lever
- D Fuel Valve Lever
- E Soap Tank
- F Handle
- G Spray Gun

- H Locking Trigger
- I Recoil Starter
- J Engine ON/OFF Switch
- K Oil Fill and Dipstick
- L Tire
- M High Pressure Hose Outlet
- N Water Inlet

PRESSURE WASHER PREPARATION

PACKING LIST

- Pressure washer
- Quick start guide
- Operator's manual and product registration card
- Engine manual
- Spray gun
- Extension wand with quick-connect fitting
- High pressure hose
- Spray nozzles (5) - 0°, 15°, 25°, 40° and soap nozzle
- Spray gun hook (upper)
- Spray gun hook (lower)
- Accessory hook
- Foot (1)
- Nozzle cleaner



WARNING: Do not attempt to assemble or operate this pressure washer until you have read and understood this entire manual. If you have any problems assembling or operating this unit, please call (800) 232-1195 M-F 8-5 CST for customer service.

WARNING: Do not operate this pressure washer if any of the parts are damaged or missing until the part is replaced. Using this product with damaged or missing parts can cause damage to the machine or result in serious injury or death.

UNPACKING

1. Remove the high pressure hose from box.
2. After the high pressure hose has been removed, carefully open product by cutting down the sides of the box.
3. Remove the product, parts, and all accessories. Make sure all items listed on the packing list are included and not damaged.

PRESSURE WASHER PREPARATION

ATTACHING FOOT ASSEMBLY (Fig. 1)

PARTS NEEDED: 1 foot, 1 M8 lock nuts.

1. Raise or tilt pressure washer so you can line up foot with the hole located at the centre of the frame.
2. Align the rubber foot with the hole in the frame where the foot is to be located. Attach foot by inserting the bolt from the bottom up and install the acorn nut. Wrench tighten until there is a slight crush on the frame tube. (Do not over tighten)

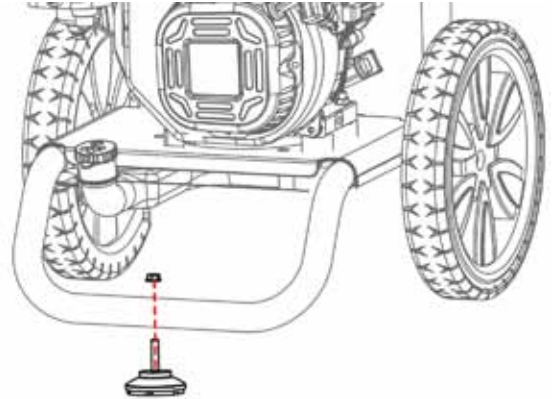

Fig. 1

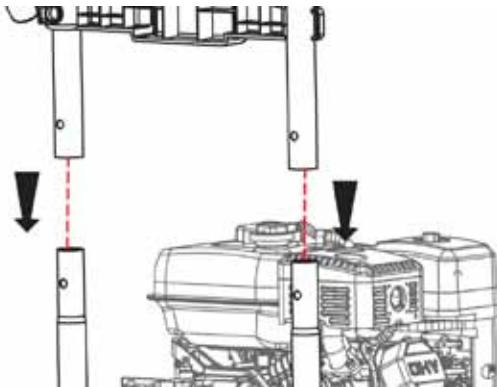

Fig. 2

INSTALL HANDLE (Fig. 2)

Install upper frame (handle) onto the lower frame by sliding the handle over the two upright tubes on the lower frame and pressing down firmly until the handle is seated and the two detent pins snap in place.

ATTACHING UPPER AND LOWER GUN HOOKS (Fig. 3)

1. Attach the upper gun hook. Align the upper gun hook with the holes. Attach using the included nuts and bolts.
2. Attach the lower gun hook. Make sure that the gun hook is straight and correctly aligned before tightening. Wrench tighten until the nut is snug. Do not over tighten.

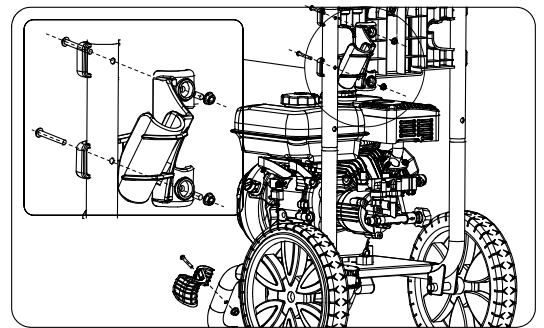

Fig. 3

PRESSURE WASHER PREPARATION

ATTACHING THE SPRAY GUN (Fig. 5 & 6)

1. Screw the spray wand and the trigger handle together until they are secure.
2. Insert the inlet coupler of the spray hose into the threaded fitting on the high pressure spray gun and thread the black nut on by turning clockwise until it is hand tight.



Fig. 5



Fig. 6

ADD ENGINE OIL

The pressure washer is shipped without oil. User must add the proper amount of oil before operating the pressure washer for the first time. The oil capacity of the engine crankcase is 15.3 fl. oz. (450 ml). For general use (above 40° F), we recommend 30W, 4-stroke engine oil.

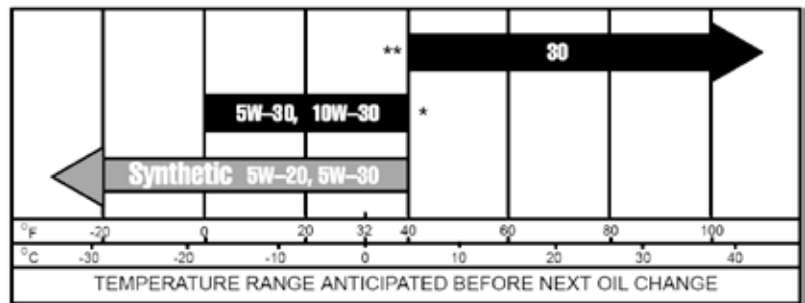

Fig. 7A

ENGINE OIL RECOMMENDATIONS

Select good quality detergent oil bearing the American Petroleum Institute (API) service classifications SJ, SL, or SM. (Synthetic oils may be used.) Use the ASE viscosity grade of oil from the following chart that matches the starting temperature anticipated before the next oil changes.

To add oil, follow these steps: (Fig. 7B)

1. Make sure the pressure washer is on a level surface. Tilting the pressure washer to assist in filling will cause oil to flow into engine areas and will cause damage. Keep pressure washer level!
2. Remove the dipstick from the engine. (Fig. 7B)
3. Add oil (not included) slowly to bring level to full.
4. To check the oil level: wipe the dipstick with a clean rag. Insert the dipstick into the oil fill opening without screwing it in. Remove the dipstick to check the oil mark.
5. Slowly add more oil and repeat step 4 until the oil mark reaches to the top of the dipstick. Do not over fill the crankcase.
6. Check for oil leaks. Tighten dipstick firmly.

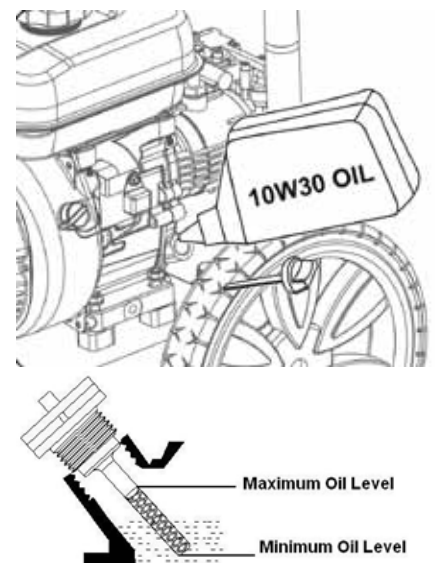

Fig. 7B

PRESSURE WASHER PREPARATION

ADD GASOLINE



WARNING: This pressure washer may emit highly flammable and explosive gasoline vapors, which can cause severe burns or even death if ignited. A nearby open flame can lead to explosion even if not directly in contact with gasoline.

Use fresh (within 30 days from purchase), lead-free gasoline with a minimum of 87 octane rating. Do not mix oil with gasoline.

To add gasoline, follow these steps: (Fig. 8)

1. Make sure the pressure washer is on a level surface.
2. Unscrew fuel cap and set aside. **NOTE:** The fuel cap may be tight and hard to unscrew.
3. Slowly add unleaded gasoline to the fuel tank. Be careful not to overfill. The capacity of the fuel tank is 1.25 gallons. **NOTE:** Do not fill the fuel tank to the very top. Gasoline will expand and spill over during use even with the fuel cap in place.
4. Reinstall fuel cap and wipe clean any spilled gasoline with a dry cloth.

IMPORTANT:

- Never use an oil/gasoline mixture.
- Only use unleaded gasoline,
- Never use old gasoline.
- Avoid getting dirt or water into the fuel tank.
- Gasoline can age in the tank and make starting difficult. Never store pressure washer for extended periods of time with fuel in the tank.



Fig. 8

NOTE: After completing the above preparation, the pressure washer is ready to be started.

PRESSURE WASHER PREPARATION

CONNECTING GARDEN HOSE TO PRESSURE WASHER (Fig. 9)

1. Run water through the hose for a few seconds to flush any debris from the hose.
2. Inspect the inlet screen and remove any debris.
3. Connect hose to water inlet and tighten by hand. There must be a minimum of 10 feet of unrestricted hose between pressure washer and faucet or shut off valve.
4. Turn on water.
5. Purge the system's pump of air by releasing the safety and squeezing the trigger of the spray gun.

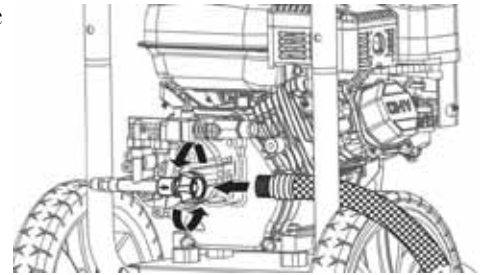

Fig. 9

CONNECT HIGH PRESSURE HOSE TO PUMP (Fig. 10)

1. Attach the end of high pressure hose to the high pressure outlet on pump.
2. Follow the same procedure with opposite end to attach high pressure hose to spray wand.

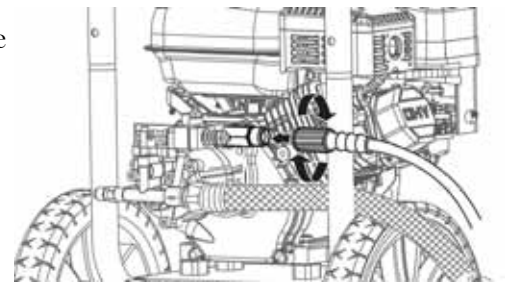

Fig. 10

OPERATION

Before starting the pressure washer, make sure you have read and performed the steps in the “Pressure washer Preparation” section of this manual. If you are unsure about how to perform any of the steps in this manual please call (800) 232-1195 M-F 8-5 CST for customer service.



DANGER: CARBON MONOXIDE.

Using a pressure washer indoors **CAN KILL YOU IN MINUTES.**

Pressure washer exhaust contains carbon monoxide (CO). This is a poison gas you cannot see or smell. If you can smell the pressure washer exhaust, you are breathing CO. Even if you cannot smell the exhaust, you may be breathing CO.

NEVER use a pressure washer inside homes, garages, crawlspaces, or other partly enclosed areas. Deadly levels of carbon monoxide can build up in these areas. Using a fan or opening windows and doors does **NOT** supply enough fresh air.

ONLY use a pressure washer outside and far away from windows, doors, and vents. These openings can pull in pressure washer exhaust. Even if you use a pressure washer correctly, CO may leak into the home. **ALWAYS** use a battery-powered or battery-backup CO alarm in the home.

If you start to feel sick, dizzy, or weak after the pressure washer has been running, move to fresh air **RIGHT AWAY**. See a doctor. You may have carbon monoxide poisoning.

OPERATION

STARTING PRESSURE WASHER (Fig. 11 & 12)

1. Place pressure washer on a level surface. Turn on water.
2. Purge the system's pump of air by releasing the safety and squeezing the trigger of the spray gun. Attach wand/lance to spray gun.
3. Turn fuel valve to the ON position.
4. Slide the choke lever to the "Choke" position.
5. Turn the engine OFF/ON switch to the "ON" position.
6. Holding the machine with your hand, pull the recoil handle (starter cord) slowly until resistance is felt, then pull rapidly. Squeeze the Gun trigger and release the pressure after every failed attempt to start the pressure washer in order to reduce back pressure.
7. Let the engine run for several seconds. Then gradually slide the choke lever to the RUN position as the engine warms up until the choke is fully slid to the RUN position.

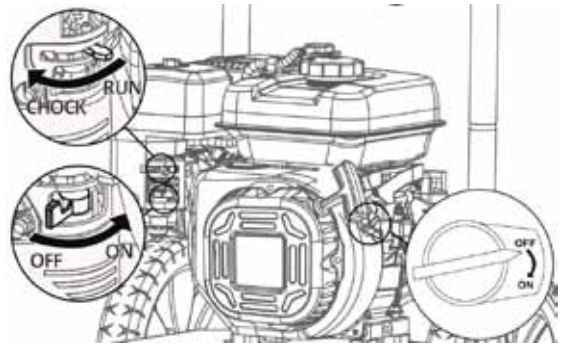

Fig. 11

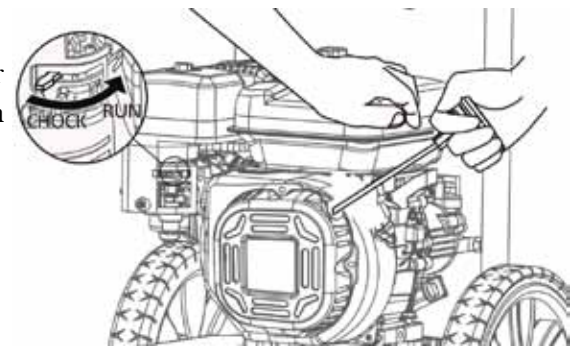



Fig. 12

 **WARNING:** Pulling the pull cord of the recoil starter rapidly can pull your arm towards the engine faster than you can let go which could result in injury.

Always relieve pressure from spray gun before pulling starter cord, including every failed attempt to start engine.

To avoid recoil, pull starter cord slowly until resistance is felt, then pull rapidly.

STOPPING PRESSURE WASHER (Fig. 13)

1. Turn the ON/OFF switch to the OFF position.
2. Turn the fuel valve to the OFF position.
3. Turn off water and squeeze the trigger handle to release all water pressure.

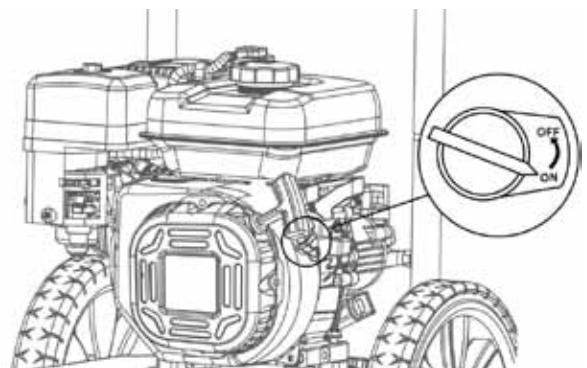

Fig. 13

PRESSURE WASHER RELEASE VALVE

If pressure within the tank exceeds the recommended PSI, excess water will begin to spray out of the pressure release valve located next to the water inlet. This is perfectly normal and acts as a corrective measure to ensure that the right amount of pressure is being used.

However, if water seems to always be leaking, its time for your pressure release valve to be replaced. Please call our customer service phone line to order parts and learn about the replacement process.

OPERATION

USING THE SPRAY GUN (Fig. 14 & 15)

Flip the lock tab behind the trigger up or down until it clicks to apply or remove the safety. Pull back on the trigger to begin operating pressure washer. To stop water flow, release trigger.

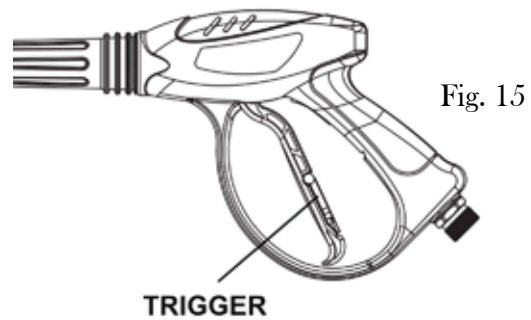
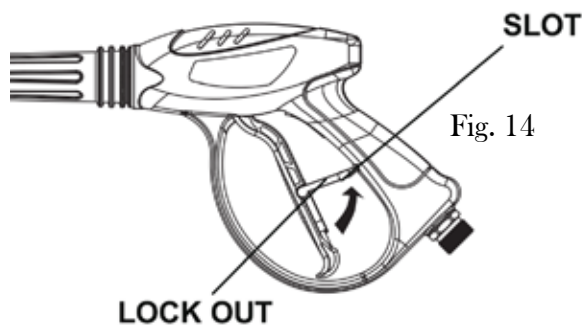

USING SPRAY NOZZLE (Fig. 16)

1. To connect or disconnect spray tip, pull back on the quick-connect collar. Insert or remove spray tip then release the collar.

2. When spray tip is connected, pull on the spray tip to make sure it is secured.

3. For general cleaning use the 40° spray tip. This option is for cement walkways.

4. For stripping, spot cleaning, blasting, and hard to reach areas use the 15° spray tip. This option is for removing paint, rust, mildew, marine growth on boats, or grease stains. This option can be used for reaching second story surfaces, or for the removal of paint, rust, oil stains, tar, gum, and other stubborn substances. Use extreme caution when using this nozzle.

5. For applying pressure washer safe detergent, use the black soap nozzle.

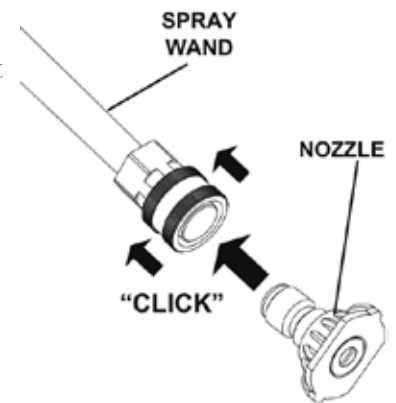

Fig. 16

APPLYING DETERGENT

1. Only use the black soap nozzle for detergent.

2. Rinse surfaces with cool water before applying cleaner.

3. Prepare detergent as required. For best results follow detergent directions as supplied from manufacturer. Remove cap from the detergent container and fill.

4. Spray detergent on surface. For best results use long, even, and overlapping strokes. Allow detergent to set for about 3 minutes before rinsing, but do not allow the detergent to dry on the surface or it may cause streaking or damage. Use good judgment.

5. To clean equipment after use, flush water through the spray nozzle for 1-2 minutes then shut off engine. Soak nozzle in a bucket of clean water to remove detergent. To empty out the soap from the pressure washer, disconnect the hose found underneath the pressure washer and let the remaining soap drain out.



WARNING: Only use detergents or soaps that are safe to be used with pressure washers. Chemicals which are caustic, such as acids or bleach, can result in serious injury, property damage, or death. NEVER aim the flow of water at a person or an animal, especially when using detergent or cleaner.

MAINTENANCE/CARE

Proper routine maintenance of the pressure washer will help prolong the life of the machine. Please perform maintenance checks and operations according to the schedule in Fig. 17.

If there are any questions about the maintenance procedures listed in this manual, please call: (800)-232-1195 M-F 8-5CT.

CAUTION: Never perform maintenance operations while the pressure washer is running.

Recommended Maintenance Schedule		Each 8 hours or daily	First 8 hours	Every 25 hours	Every 3 months or 50 hours	Every 6 months or 100 hours	Every year	As necessary
Engine oil	Check level	x						
	Replace		x	x*	x*			x
Air cleaner cartridge	Check			x		x		
	Clean					x		
Spark plug	Check/clean					x		
	Change						x	x
Fuel tank	Check level	x						
	Clean						x	

Fig. 17 - Recommended maintenance schedule

* Clean/change more often under dusty conditions or when operating under heavy load.

PRE-OPERATION STEPS

Before starting the engine, perform the following pre-operation steps:

1. Check the level of the engine oil and the fuel tank.
2. Make sure the air filter is clean.
3. Remove any debris that has collected on the pressure washer.
4. Check high pressure hose for damage.
5. Briefly run garden hose to flush out any debris or insects.
6. Inspect the work area for hazards.
7. Clean any debris that has collected around or behind the muffler, air cleaner and controls.
8. Use a damp cloth to wipe exterior surfaces. If dirt is caked on, use a soft bristle brush.

MAINTENANCE & CARE

AFTER EACH USE

Follow these procedures after each use:

1. Shut off engine and turn off water supply. Release water pressure by pointing spray gun in a safe direction and squeezing the trigger.
2. Disconnect high pressure hose, spray gun, and nozzle. Drain water from items and use a rag to wipe down the outside of the hose and spray gun.
3. Empty the water from the pump by pulling the recoil starter 6 times.
4. Store unit in a clean and dry area after it has had a chance to cool down.
5. Use of a pressure washer pump conditioner is recommended, particularly for winter storage. Follow the instructions provided by the manufacturer of the pump conditioner.

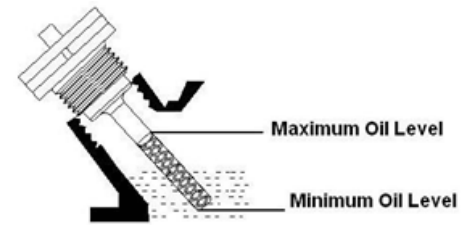

Fig. 18 - Oil Fill Opening, Dipstick and Oil Level

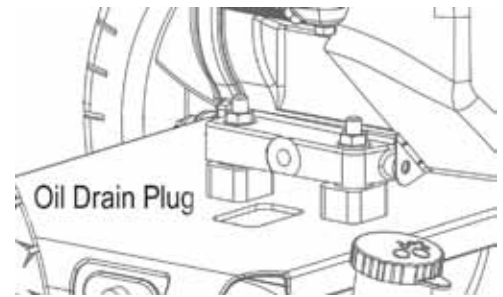

Fig. 19

CHECKING THE OIL

Check the oil level of the pressure washer according to the Recommended Maintenance Schedule in Figure 17. The pressure washer should be checked before each use for proper oil level. This is a critical step for proper engine starting. To check the oil level:

1. Make sure the pressure washer is on a level surface.
2. Clean around oil fill. Remove dipstick and wipe the dipstick with a clean rag. Insert the dipstick into the oil fill opening without screwing in. Remove the dipstick to check the oil mark. Add oil if the oil mark covers less than one half of the dipstick.
3. Slowly add more oil and repeat step 2 until the oil mark reaches to the top of dipstick (Fig. 18). Do not over fill the crankcase.
4. Reinstall oil dipstick and access panel.

CHANGING/ADDING OIL (Fig. 19)

Change the oil according to the Recommended Maintenance Schedule in Fig. 17. Change the oil when the engine is warm to allow for complete drainage. Change oil more often if operating under heavy load or high ambient temperatures. It is also necessary to drain the oil from the crankcase if it has become contaminated with water or dirt. The oil capacity of the pressure washer engine is 15.3 fl oz (450 ml). Add oil when the oil level is low. For proper type of oil refer to the “add oil” portion of the “Pressure washer Preparation” section. To change oil:

1. Shut off engine. Clean the area around the oil fill cap/dipstick to keep out debris then remove oil fill cap/dipstick.
2. Place an oil pan on the ground to catch oil. Remove oil plug then tilt pressure washer back and to the side to empty out the oil from the crankcase.
3. Once oil is completely drained, return the pressure washer to a level position and install the oil drain plug. Refill the engine with new oil as instructed earlier in this manual under Adding/Checking Oil.

MAINTENANCE & CARE

AIR CLEANER MAINTENANCE

Routine maintenance of the air cleaner helps maintain proper airflow to the carburetor. Occasionally check that the air cleaner is free of excessive dirt. Refer to Recommended Maintenance Schedule in Fig. 17.

1. Unscrew the cover bolt, then remove the air cleaner cover.
2. Remove the air cleaner element from the casing.
3. Check and clean the air cleaner element. Replace with a new one if the element is damaged. Good element can be washed in soapy water, dried and reused. There is no need to add oil to the element.
4. Wipe off excessive oil from the air cleaner case. Small amount of oil in the element is normal and necessary for the engine to work properly.
5. Reinstall the air cleaner element and cover.

CAUTION: running the engine with dirty, damaged or missing air cleaner element will cause the engine to wear out prematurely.

DRAINING THE FUEL TANK

Clean fuel tank each year or before storing the pressure washer for extended periods of time. To drain the fuel tank and carburetor:

1. Turn the fuel valve to the “OFF” position. Remove the fuel line between the fuel valve and carburetor.
CAUTION: a small amount of fuel may leak from the hose during removal.
2. Attach a fuel line (not included with the pressure washer) to the exposed end of the fuel valve. Position fuel line into an appropriate container and open the fuel valve allowing fuel to flow into the container.
3. Once fuel is drained, shut off the fuel valve. Start and run the engine until fuel runs out.

CAUTION: Store the emptied gasoline in a safe place. Do not store fuel for more than 3 months.

DRAINING THE SOAP

To drain the soap, unplug the hose highlighted in Figure 20. Use a container to hold the draining soap. Once the soap is done draining, reconnect the hose.

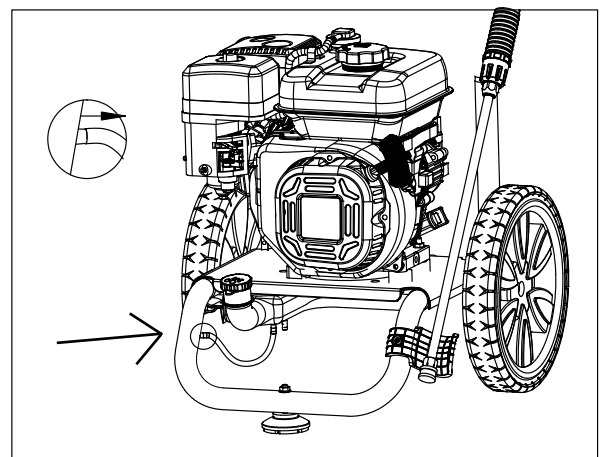

Fig. 20

MAINTENANCE & CARE

SPARK PLUG MAINTENANCE

The spark plug is important for proper engine operation. A good spark plug should be intact, free of deposits, and properly gapped. Refer to Recommended Maintenance Schedule in Fig. 17. To inspect the spark plug:

1. Remove spark plug boot. Be careful not to tear insulation or wiring.
2. Unscrew the spark plug from the engine using the spark plug wrench provided. There is limited space for the wrench to turn. Use both rows of holes in the spark plug wrench to gain leverage to loosen the plug.
3. Visually inspect the spark plug for cracks or excessive electrode wear. Replace as necessary.
4. Measure the plug gap with a wire gauge. The gap should be 0.7-0.8 mm (0.028-0.031 in).
5. If re-using the spark plug, use a wire brush to clean any dirt from around the spark plug base then re-gap the spark plug.
6. Screw the spark plug back into the spark plug hole using the spark plug wrench. Do not over-tighten spark plug. Recommended tightening of spark plug is $\frac{1}{2}$ to $\frac{3}{4}$ of a turn after the spark plug gasket contacts the spark plug hole. Reinstall the spark plug boot.

CHECKING DETERGENT SIPHONING TUBE

1. Check the detergent siphoning tube for clogs, leaks, or tears.
2. Make sure the tube fits tightly to the pump fitting.
3. Replace siphoning tubes if damaged.



Nozzle Cleaner

HIGH PRESSURE HOSE

1. Inspect hose for cuts, bulges, or leaks which can develop from kinking or wear. If damage is found, immediately replace hose.
2. Inspect couplings for damage. Immediately replace hose if damage is found.

WARNING: Never repair a high pressure hose or use unit if the hose is damaged. If the hose is damaged replace with identical part.

SPRAY GUN

1. Make sure the spray gun is connected securely.
2. Inspect the spray gun safety and make sure the spray gun trigger springs back upon release.

MAINTENANCE & CARE

SPRAY NOZZLE

If a pulsing sensation is felt while squeezing the trigger, the spray nozzle may be dirty or clogged and should be cleaned immediately. To clean the nozzle:

1. Shut off the engine and turn off the water.
2. Remove the nozzle from the spray wand, making sure that the nozzle is pointing away from you and in a safe direction.
3. Use the nozzle cleaner or a small paper clip to dislodge any foreign materials which are clogging or restricting the spray tip. Flush debris out of the nozzle by back flushing with a garden hose for 30-60 seconds.
4. Reconnect the nozzle to the spray wand.
5. Turn the water supply back on and start engine.

STORAGE & TRANSPORT PROCEDURES

CAUTION: Never place any type of storage cover on the pressure washer while it is still hot.

If the pressure washer is being stored for short periods of time (30 to 60 days), add stabilized fuel to the fuel tank until full. **NOTE:** Filling the tank reduces the amount of air in the tank and helps reduce deterioration of fuel. Run the engine for 2 - 3 minutes allowing stabilized fuel mixture to circulate through the carburetor.

STORING THE PRESSURE WASHER FOR EXTENDED PERIODS:

1. Drain the fuel tank (see “Draining the Fuel Tank” in the “Maintenance” section).
2. Change oil.
3. Do not obstruct any ventilation openings.
4. Keep the pressure washer in a cool dry area.

TRANSPORTING THE PRESSURE WASHER:

1. Tighten fuel cap. Drain the fuel tank if possible (see “Draining the Fuel Tank” in the “Maintenance” section).
2. Always keep the pressure washer upright. Do not lay it down sideways.

SPECIFICATIONS

Pressure Washer

Max. Pressure	3100 PSI
Max. Flow	2.5 GPM - 3100 PSI
Nozzles	0°, 15°, 25°, 40°, Soap Nozzle
Gun to Lance Connection	M22 Threaded
Gun to Hose Connection	M22 Threaded
Lance Length	20" Stainless
Lance to Nozzle Connection	Quick Change
Pump	Axial Cam
Detergent Tank Capacity	0.25 Gallon
Hose Diameter	5/16"
Hose Length	30'
Wheel	12"
Weight	67 lbs

Engine

Engine type	4 stroke, OHV, single cylinder with forced air cooling system
Spark plug gap	0.7 - 0.8 mm (0.028 - 0.031 in)
Spark plug torque	1/2 - 3/4 turn after gasket contacts base or 15 ft.lb
Displacement	208 cc
Fuel tank capacity	0.9 gallon 87 octane minimum
Oil capacity	15.3 fl. oz (450 ml)
Lubrication system	Splash lubrication
Noise rating	63 dB at 22 feet
Spark plug	NGK BP7ES

TROUBLESHOOTING

IMPORTANT: If trouble persists, please call our customer help line at (800) 232-1195 M-F 8-5 Central Time.

Problem	Cause	Solution
Engine will not start	Engine switch is set to "OFF".	Set engine switch to "ON".
	Fuel valve is turned to "OFF".	Turn fuel valve to "ON" position.
	Choke is open.	Close the choke
	Engine is out of fuel.	Add gasoline.
	Engine is filled with contaminated or old gasoline.	Change the gasoline in the gas tank.
	Spark plug is dirty.	Clean spark plug.
	Spark plug is broken.	Replace spark plug.
	Generator is not on level surface.	Move generator to a level surface to prevent low oil shutdown from triggering.
	Oil is low.	Add or replace oil.
Water pressure is weak	Water supply is restricted.	Inspect garden hose for leaks. Make sure you are using a large enough garden hose (min. ¾ inch diameter).
	Water not turned on to full power	Open water source all the way.
	Not using high pressure nozzle	Change nozzle.
Detergent and spray do not mix	Detergent hose is not submerged or has disconnected	Make sure hose is connected and submerged in the detergent.
	Black soap nozzle needed	Use soap nozzle.
Pump fails to produce pressure or pressure is inconsistent	Water supply is restricted	Inspect garden hose for leaks. Make sure you are using a large enough garden hose (min. ¾ inch diameter).
	Water not turned on full power	Open water source all the way.
	Nozzle is clogged	Clean nozzle.
	Spray gun leaks	Check spray gun connection or replace spray gun
	Air in line	Squeeze trigger handle to remove air
	Inlet hose screen is clogged	Clean inlet.
	Water supply is over 100°F	Use cool water supply.
Pump is faulty	Contact service department.	

EXPLODED VIEW AND PARTS LIST

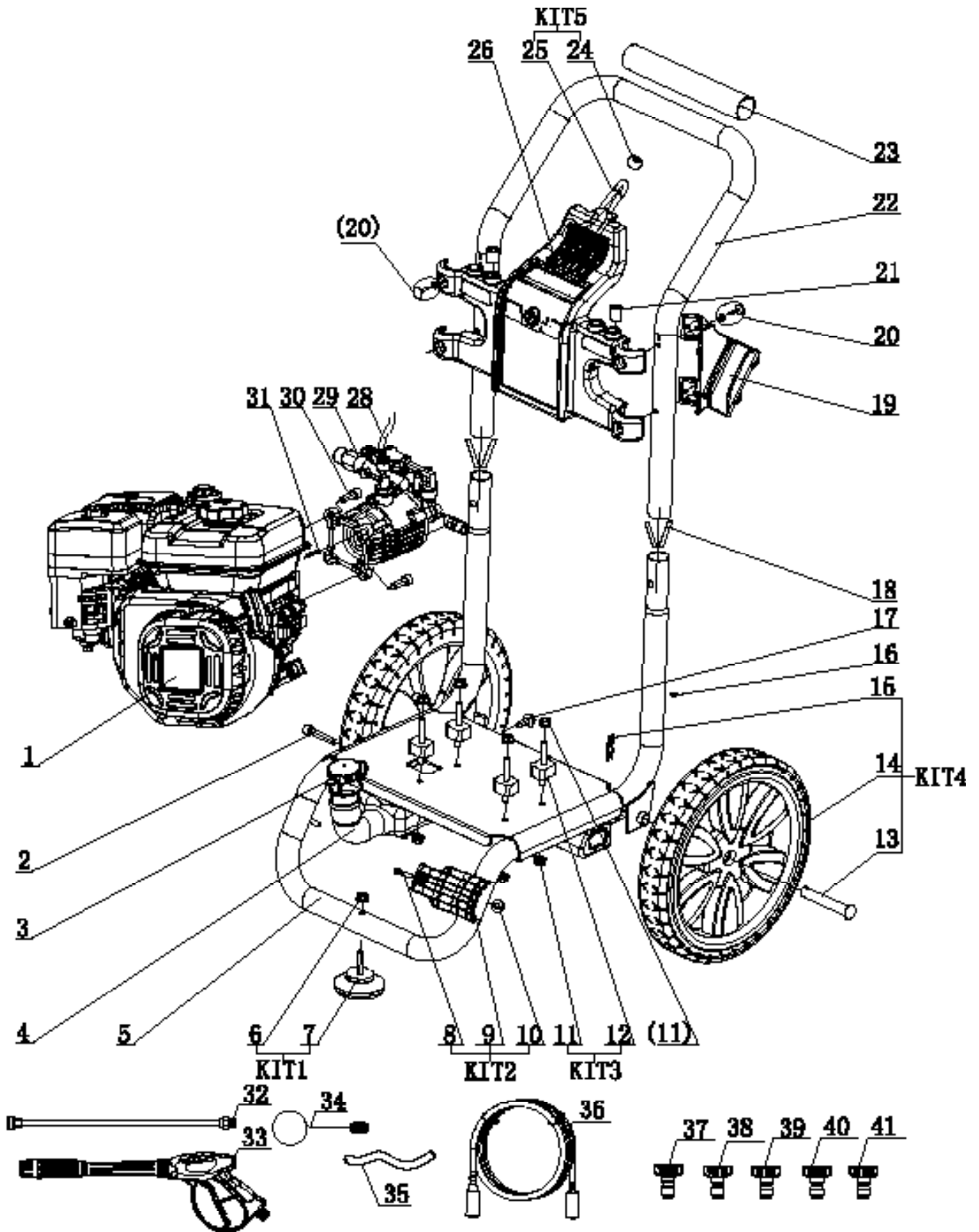

EXPLODED VIEW AND PARTS LIST

No.	Part Number	Description
1	PW31-001	Engine
2	PW31-002	M6 x 40 Bolt
3	PW31-003	Detergent Tank Cap
4	PW31B-004	Detergent Tank
5	PW31B-005	Lower "A" Frame Assembly
6	PW31-006	M8 Lock Nut
7	PW31-007	Foot
8	PW31-008	M6 Screw
9	PW31-009	Lower Gun Hook
10	PW31-010	M6 Lock Nut
11	PW31-011	M8 Bolt
12	PW31-012	Engine Mount
13	PW31-013	Wheel Axle
14	PW31-014	12" Wheel
15	PW31-015	Cotton Pin
16	PW31-016	Tubing Clip
17	PW31-017	M6 x 16 Bolt
18	PW31-018	Spring
19	PW31-019	Upper Gun Hook
20	PW31B-020	Bolt and Nut
21	PW31-021	Nozzle Holder
22	PW31-022	Handle
23	PW31-023	Foam Grip
24	PW31-024	Bungee Cord Knob
25	PW31-025	Bungee Cord
26	PW31-026	Panel
28	PW31-028	Siphon Tube
29	PW31-029	Water Pump
30	PW31-030	Bolt M8x20
31	PW31-031	Output Shaft Key
32	PW31-032	Lance
33	PW31-033	Spray Gun
34	PW31-034	Nozzle Cleaner
36	PW31-036	High Pressure Hose
37	PW31-037	Red Nozzle 0°
38	PW31-038	Yellow Nozzle 15°
39	PW31-039	Green Nozzle 25°
40	PW31-040	White Nozzle 40°
41	PW31-041	Black Soap Nozzle

EXPLODED VIEW AND PARTS LIST

NO.	Part Number	Product Description	Qty.
1	PW31-101	Crankcase	1
2	PW31-102	Ball Bearing	2
3	PW31-103	Oil Seal	2
4	PW31-104	Governor Arm	1
5	PW31-105	Governor Shaft	1
6	PW31-106	Governor Shaft Washer	1
7	PW31-107	Locking Pin	1
8	PW31-108	Oil Drain Plug	2
9	PW31-109	Drain Plug Washer	2
10	PW31-110	Dowel Pin	2
11	PW31-111	Piston	1
12	PW31-112	Piston Ring Assembly	1
13	PW31-113	Conecting Rod Assembly	1
14	PW31-114	Piston Pin	1
15	PW31-115	Piston Clip	2
16	PW31-116	Crankcase Cover	1
17	PW31-117	Oil Plug	1
18	PW31-118	Dipstick	1
19	PW31-119	Cylinder Head	1
20	PW31-120	Intake Valve	1
21	PW31-121	Exhaust Valve	1
22	PW31-122	Intake Valve Return	1
23	PW31-123	Valve Spring	2
24	PW31-124	Intake Valve Seat	1
25	PW31-125	Exhaust Valve Seat	1
26	PW31-126	Push Rod Guide Plate	1
27	PW31-127	Rocker Arm Assembly	2
28	PW31-128	Rotator	1
29	PW31-129	Stud Bolt	2
30	PW31-130	Stud Bolt	2
31	PW31-131	Carburetor Assembly	1
31.1		Float	1
31.2		Fuel Injection Needle	1
31.3		Main Metering Jet	1
32	PW31-132	Fuel Line	1
33	PW31-133	Fuel Line Clip	2
34	PW31-134	Governor Arm	1
35	PW31-135	Bolt	1
36	PW31-136	Nut	3
37	PW31-137	Crankshaft Assembly	1
38	PW31-138	Valve Lifter	2
39	PW31-139	Cascover Gasket	1
40	PW31-140	Camshaft Assembly	1
41	PW31-141	Dowel Pin	2
42	PW31-142	Bolt	6
43	PW31-143	Cylinder Head Gasket	1
44	PW31-144	Bolt	4
45	PW31-145	Spark Plug	1
46	PW31-146	Push Rod	2

NO.	Part Number	Product Description	Qty.
47	PW31-147	Shroud	1
48	PW31-148	Bolt	12
49	PW31-149	Headcover Gasket	1
50	PW31-150	Cylinder Head Cover	1
51	PW31-151	Recoil Bracket	1
52	PW31-152	Bolt	1
53	PW31-153	Flywheel Assembly	1
54	PW31-154	Recoli Fan	1
55	PW31-155	Recoil Flange	1
56	PW31-156	Nut	1
57	PW31-157	Ignition Coil Assembly	1
58	PW31-158	Bolt	2
59	PW31-159	Intake Gasket	1
60	PW31-160	Carbuertor Insulator	1
61	PW31-161	Carubertor Gasket	1
62	PW31-162	Carbuertor Spacer	1
63	PW31-163	Governor Rod	1
64	PW31-164	Throttle Return Spring	1
65	PW31-165	Recoil Starter Assembly	1
65.1		Recoil	1
65.2		Recoil Handle	1
65.3		Recoil Rope	1
65.4		Recoil Case	1
66	PW31-166	Switch	1
67	PW31-167	Upper Shroud Assembly	1
68	PW31-168	Air Cleaner Assembly	1
68.1		Air Cleaner Bottom Cover	1
68.2		Air Cleaner Element	1
68.3		Air Cleaner Cover	1
69	PW31-169	Governor Spring	1
70	PW31-170	Clip	1
71	PW31-171	Exhaust Packing	1
72	PW31-172	Muffler	1
73	PW31-173	Nut	2
74	PW31-174	Spring Washer	2
75	PW31-175	Fuel Tank Assembly	1
75.1		Fuel Filter	1
76	PW31-176	Fuel Tank Cap	1
77	PW31-177	Connecting Pipe	1
78	PW31-178	Manual Choke	1
79	PW31-179	One Way Valve	1
80	PW31-180	Fuel Line Clip	1
81	PW31-181	Fuel Line Clip	1
82	PW31-182	Bolt	1
83	PW31-183	Nut	2
84	PW31-184	Wire Harness	1
85	PW31-185	Rocker Arm	2
86	PW31-186	Breather Tube Inlet	1
87	PW31-187	Breather Tube	1

WARRANTY STATEMENT

Remember to save the receipt. Proof of purchase is required for all warranty work.

WEN® pressure washers are under warranty to be free from defects in materials and workmanship for a period of two (2) years from date of original purchase. Pressure washers used for commercial or rental use have a warranty period of 90 days from date of original purchase. Keep purchase receipt and mail in the product registration card for proof of purchase.

WEN® will repair or replace, at its discretion, any part that is proven to be defective in materials or workmanship under normal use during the two (2) years warranty period. Warranty repairs or replacements will be made without charge for parts or labor. Parts replaced during warranty repairs will be considered as part of the original product and will have the same warranty period as the original product.

To exercise the warranty, **DO NOT RETURN TO RETAILER**. Instead, call the toll free Customer Service number at (800) 232-1195 and you will be instructed on where to take the pressure washer for warranty service. Take the pressure washer, the manual, and the proof of purchase (the receipt) to the nearest repair facility recommended by the Customer Service Representative.

To make a claim under this Limited Warranty, you must make sure to keep a copy of your proof of purchase that clearly defines the Date of Purchase (month and year) and the Place of Purchase. Place of purchase must be a direct vendor of Great Lakes Technologies, LLC. Third party vendors such as garage sales, pawn shops, resale shops, or any other secondhand merchant void the warranty included with this product. Contact techsupport@wenproducts.com or 1-800-232-1195 to make arrangements for repairs and transportation.

When returning a product for warranty service, the shipping charges must be prepaid by the purchaser. The product must be shipped in its original container (or an equivalent), properly packed to withstand the hazards of shipment. The product must be fully insured with a copy of the warranty card and/or the proof of purchase enclosed. There must also be a description of the problem in order to help our repairs department diagnose and fix the issue. Repairs will be made and the product will be returned and shipped back to the purchaser at no charge.

THIS LIMITED WARRANTY DOES NOT APPLY TO ACCESSORY ITEMS THAT WEAR OUT FROM REGULAR USAGE OVER TIME INCLUDING BELTS, BRUSHES, BLADES, ETC.

The warranty does not extend to pressure washers damaged or affected by fuel contamination, accidents, neglect, misuse, unauthorized alterations, use in an application for which the product was not designed and any other modifications or abuse. Parts that need regular maintenance such as recoil starters, spark plugs, air filters, etc. are also not covered under the warranty.

WEN® is not liable for any indirect, incidental or consequential damages from the sale or use of this product. Any implied warranties are limited to two (2) years as stated in this written limited warranty. Some states do not allow the exclusion or limitation of incidental or consequential damages. Some states do not allow limitation on the length of an implied warranty. This warranty gives you specific legal rights, and you may have other rights that vary from state to state.