

AQUA POWER®

C-4 Self-Contained Deep Cleaning Extractor Maintenance & Use Manual



From
VortexTec™

TABLE OF CONTENTS

	PAGE
<u>INTRODUCTION</u>	
When the Machine is Delivered	1
Before Operating the Machine	1
<u>IMPORTANT SAFETY INSTRUCTIONS</u>	
General Instructions	1
Warnings	2
Grounding Instructions	2
<u>CARPET CLEANING INSTRUCTIONS</u>	3-4
<u>UPHOLSTERY CLEANING INSTRUCTIONS</u>	
After Each Use of Machine	4
<u>MACHINE OPERATION TROUBLESHOOTING</u>	
Loss of Electrical Power	5
Loss of Vacuum	5
Little or No Suction	5
Streaking/Lack of Water Pressure	5
No Brush Movement	5
<u>RETURNING C-4 TO RENTABLE CONDITION</u>	6
<u>6 MONTH INSPECTION AND SERVICE</u>	6
<u>SERVICE WARNINGS</u>	6
<u>WARRANTY</u>	5
<u>REPAIR TROUBLESHOOTING GUIDE</u>	
Electrical System	7
Vacuum System	8-9
Pump System	10-11
Brush System	11-12
Removing the Vacuum and Brush Assemblies	13
Replacing the Vacuum Motor	13
Replacing the Brush Motor	13
Replacing the Pump Motor	14
Removing the Brush Assembly	14
Servicing and Rebuilding the Brush	14
Replacing the Front Nozzle Clip	14
Replacing the Rear Nozzle Clip	15
Replacing the Trigger Switch	15
Replacing the Rocker Switch	15
Replacing Terminals	15
Wiring Lever Nuts	15
Coupler Repair	16
Replacing Drain Tube	16
Testing Lid	16
<u>REPAIR MANUAL</u>	
	17-40

CONTACT INFORMATION:

customerservice@kentinv.com

Order Desk: 800.573.8066 Phone: 870.994.3535 Fax: 870.994.3545

Kent Investment Corp.

Mailing Address: PO Box 279 Ash Flat, AR 72513

Shipping Address: 250 Hwy 62-West Ash Flat, AR 72513

INTRODUCTION

BEFORE YOU USE YOUR OWNER'S MANUAL, PLEASE READ THIS INTRODUCTION ALL THE WAY THROUGH.

WHEN THE MACHINE IS DELIVERED:

Check the carton carefully for signs of damage and rough handling. Remove the machine from the carton. If the machine is damaged, notify the carrier immediately and request an inspection. Be sure to keep the carton, packing list and carrier's receipt until the inspector has verified your claim.

Kent Investment's liability ceases when the shipment is picked up by the carrier, but our customer service staff will be glad to furnish any information needed in connection with the claim and will expedite repair of the machine.

BEFORE OPERATING THE MACHINE

Read the manual carefully before operating Model C-4. The manual has important information for the use and safe operation of the machine. Keep this manual handy at all times. Model C-4 will assure years of satisfactory service if operated and maintained according to recommendations in this manual. If additional technical information is needed, please contact Kent Investment Corporation at 870.994.3535.

All information and specifications printed in this manual and parts list are current at the time of printing; however, because of Kent Investment's policy of continual product improvement, we reserve the right to make changes at any time without notice.

WARRANTY: See page 5 of this manual for limited warranty.

THIS MACHINE IS FOR COMMERCIAL USE.

IMPORTANT SAFETY INSTRUCTIONS

When using an electrical appliance, basic precautions should always be followed, including the following:

READ ALL INSTRUCTIONS BEFORE USING MODEL C-4.

GENERAL INSTRUCTIONS

This floor finishing machine shall be grounded while in use to protect the operator from electric shock. The machine is provided with a three-conductor cord and a three-contact grounding type attachment plug to fit the proper grounding type receptacle. The green (or green and yellow) conductor in the cord is the grounding wire. NEVER connect this wire to other than the grounding pin of the attachment plug.

WARNING - TO REDUCE THE RISK OF FIRE, ELECTRICAL SHOCK, PERSONAL INJURY OR DAMAGE TO MODEL C-4:

1. DO NOT leave appliance when plugged in. Unplug from outlet when not in use and before servicing.
2. To reduce the risk of electrical shock - DO NOT expose to rain. Store indoors.
3. This machine is intended for carpet and upholstery cleaning only!
4. Fill tank with machine bucket only! Machine must be emptied after 3 1/2 gallons of water and solution have been used.
5. DO NOT allow to be used as a toy. Close attention is necessary when used by or near children.
6. Use only as described in this manual. Use only Kent Investment Corp. recommended attachments and chemicals.
7. DO NOT use with damaged cord or plug. If appliance is not working as it should, has been dropped, damaged, left outdoors, or immersed in water, contact Kent Investment Corporation service department for service instructions.
8. DO NOT pull or carry by cord, use cord as a handle, close door on a cord, or pull cord around sharp edges or corners. DO NOT run equipment over cord. Keep cord away from heated surfaces.
9. DO NOT unplug by pulling on cord. To unplug, grasp the plug, not the cord.
10. DO NOT handle plug or equipment with wet hands.
11. DO NOT put any object into openings. DO NOT use with any openings blocked; keep free of dust, lint, hair, and anything that may reduce airflow.
12. Keep hair, loose clothing, fingers and all parts of body away from openings and moving parts.
13. DO NOT vacuum anything that is burning or smoking, such as cigarettes, matches, or hot ashes.
14. DO NOT use without filter screens in place.
15. Turn off all controls before unplugging.
16. Use extra care when cleaning stairs.
17. NEVER vacuum solvents, gasoline or other hazardous liquid or solid material or use in areas where they may be present.
18. Connect to a properly grounded outlet only. See grounding instructions.

GROUNDING INSTRUCTIONS

This machine is for use on a nominal 120-volt circuit and has a grounding plug that resembles the plug illustrated in sketch (A) (RIGHT). Make sure that the machine is connected to an outlet having the same configuration as the plug. No adapter should be used with this machine.

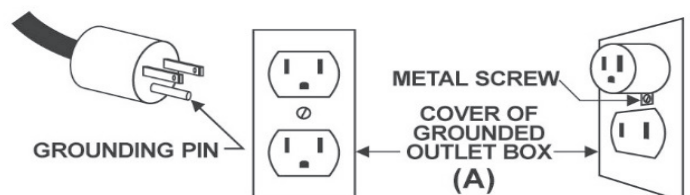

FOR CUSTOMERS IN CANADA:

CAUTION! To prevent electrical shock, do not use this polarized AC plug with an extension cord, receptacle or other outlet unless the blades can be fully inserted to prevent blade exposure.

CLEANING DIRECTIONS

Preparing Carpet & Upholstery

- 1) Vacuum carpet or upholstery with your home vacuum cleaner. This machine is not a vacuum cleaner.
NOTE: We recommend vacuuming carpet thoroughly, making four passes with a CRI approved vacuum cleaner.
- 2) Pre-treat general spots with **7 IN 1 Carpet Care**. Pre-treat pet & acid based spots with **7 IN 1 Spot & Odor Pet Formula**. Pre-treat heavily soiled areas of carpet, hallways, doorways and around furniture with **7 IN 1 Hi-Traffic Pre-Treatment**.
Note: Read and follow all **7 IN 1** label directions prior to use.

Preparing Machine

- 1) Pull "T" Handle on machine Handle.
- 2) Raise machine Handle to desired height.

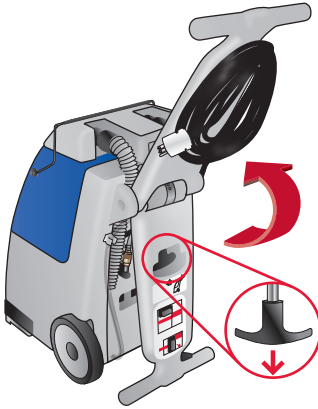

- 1) Pull down Bucket Handle.
- 2) Lift the Lid.
- 3) Remove the Bucket.



- 1) Read and follow all **7 IN 1 Carpet Care** directions. Mix **7 IN 1** with water in Bucket according to **Quick Dry** directions.
Note: Do not fill Bucket above top fill line.
Warning: Do not use bleach or dye in this machine. User will be liable for all damages.



- 1) **Important:** Pour contents of Bucket into machine Solution Tank.

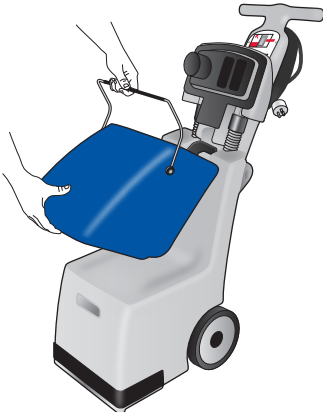

- 1) Return Bucket to Solution Tank.
- 2) Close Lid.
- 3) Snap Bucket Handle into place.



- 1) Turn all switches OFF.

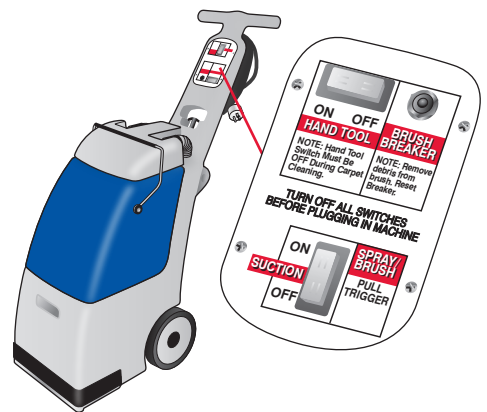

Cleaning Carpet

- 1) Plug in machine to a grounded outlet. See Grounding Instructions.

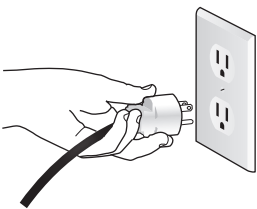

- 1) Tilt the machine back and move into the starting position.

- 2) Turn ON the Suction Switch.
Note: Hand Tool Switch must be OFF.
- 3) Pull the Spray/Brush Trigger and pull the machine backwards at a slow steady pace, about 1 foot per 2 seconds. Clean in approximately 5 foot strokes. Overlap strokes by 2 inches, releasing the Trigger 6 inches before ending each stroke. Keep the Suction Nozzle in firm contact with the carpet.
Note: For best results, clean heavily soiled areas twice at right angles.



- 1) Dirty water passes through the right Sight Tube while cleaning. When dirty water stops passing through the Sight Tube while cleaning, the machine is empty. Empty dirty water from and rinse Bucket. Refill the machine.
- 2) If foam or liquid appears in the left Sight Tube, empty the dirty water from the Bucket without refilling the machine.
- 3) When finished cleaning, empty and rinse Bucket. Use the clear Drain Tube at the back of the unit to empty unused solution from the Solution Tank.

- Note:** Use the Hand Tool for cleaning stairs. See Cleaning Upholstery for Hand Tool use.

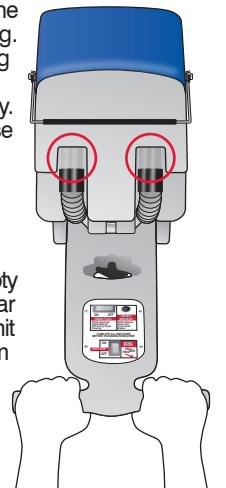

CLEANING DIRECTIONS

Cleaning Upholstery

- 1) Turn all Switches OFF.
- 2) Disconnect the machine Solution Hose. Pull down on the middle of the brass Coupler. The hose will release. While holding down the Coupler, insert the Hand Tool Kit Solution Hose. Release Coupler. Pull on the Solution hose to insure it is secured.
- 3) Disconnect the grey and black Vacuum Cuffs at the back of the machine. Connect the grey Hand Tool Kit Cuff to the grey machine Cuff.

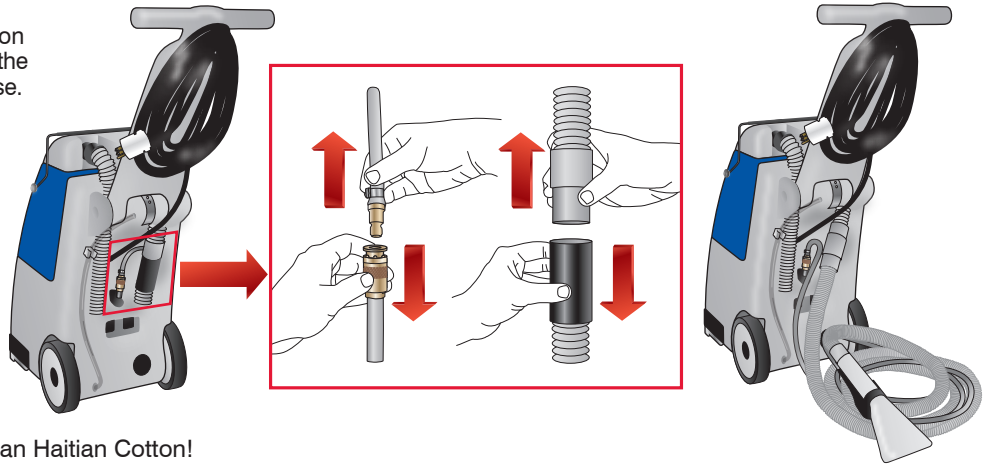

WARNING: Do Not Use To Clean Haitian Cotton!

- 1) Read **7 IN 1 Carpet Care** directions. See: Test Colorfastness and Upholstery Cleaning Directions. Mix **7 IN 1** with water in Bucket according to directions.
- Note:** For upholstery cleaning, mix 1.5 gallons of cleaner at a time.

- 1) **Important:** Pour contents of Bucket into machine Solution Tank.

- 1) See Preparing Carpet & Upholstery.
- 2) Turn ON the Suction and Hand Tool Switches.
- 3) Squeeze the Hand Tool Trigger as you pull up or back with overlapping even strokes.

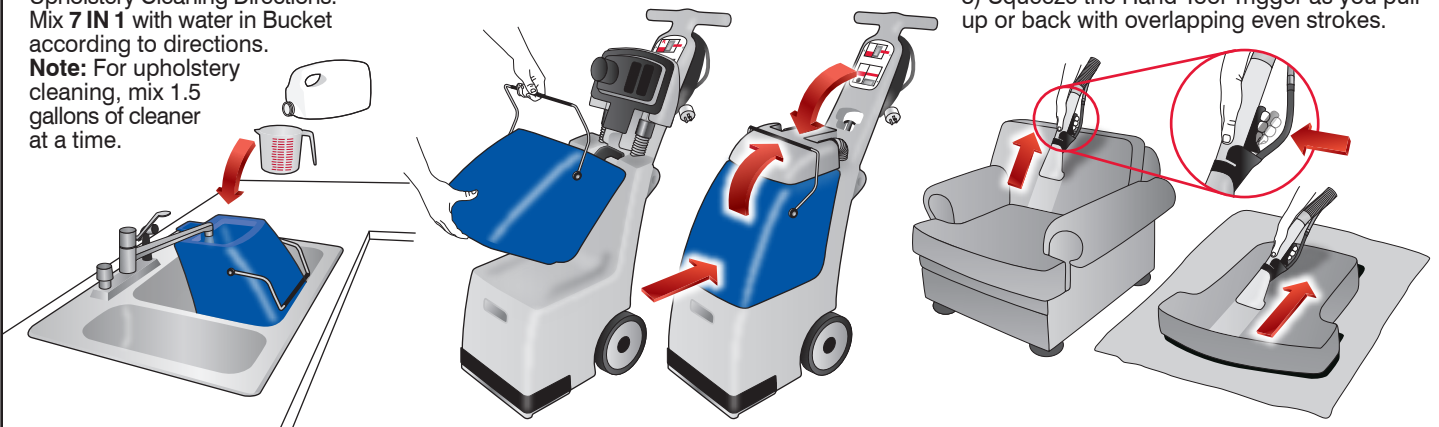

Cleaning Stairs

1. Use the Hand Tool to clean stairs. (See Cleaning Upholstery to hook up hand tool.)
2. Clean the upstairs rooms first, then the stairs.
- IMPORTANT:** When cleaning the upper stairs, turn machine sideways so wheels are NOT facing forward, toward stairs. Be careful bringing the machine down wet stairs. Make sure to empty the Bucket and Solution Tank using the Drain Hose.
3. Turn on Suction and Hand Tool Switches.
4. Place Hand Tool Suction Nozzle on carpet and squeeze Trigger while pulling backwards.

Cleaning Machine

- 1) Wipe hair and debris from the Lid.
- 2) Drain unused solution from Solution Tank.
- 3) Dispose of solution and rinse Bucket thoroughly.
- 4) Clean out the Vac Nozzle with a hanger.
- 5) Remove fibers and hair from the Brush.
- 6) Wipe Brush Chamber clean with towel.
- 7) Wipe off the exterior of the machine with a damp towel.

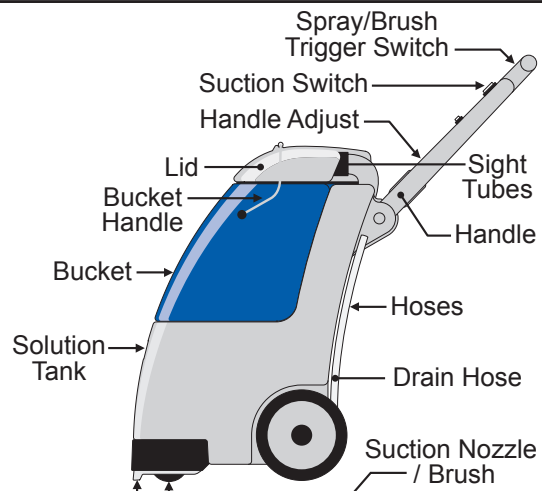

MACHINE OPERATION TROUBLESHOOTING

LOSS OF ELECTRICAL POWER

- 1) Check if the Switches are in the ON position.
- 2) Check to see if Electric Cord is plugged in.
- 3) Check if the Brush Circuit Breaker has tripped. Clear brush of debris until brush turns freely. Then reset the breaker.
- 4) Check circuit breakers or fuse box in your building.
- 5) Check if the outlet is wired to a light switch, or try using a different outlet.
- 6) If Machine keeps blowing breakers or fuses every time you turn it on, have a qualified repair center check the equipment.

LOSS OF VACUUM / LITTLE OR NO SUCTION

- 1) Check if hose cuffs on back of the machine are connected. (See illustration on page 4.)
- 2) Be sure the suction switch is on. If you don't hear any sound from the vacuum, have a qualified repair center check the equipment.
- 3) Be sure the lid is firmly seated in the bucket and the bucket handle is snapped in place.
- 4) As you make a backwards cleaning stroke, be sure the suction lips are down firmly on the carpet.
- 5) Brush off any accumulated lint or debris on the vacuum filter screen located on the bottom of the lid.
- 6) The vacuum nozzle may be stopped up with lint. Turn the machine OFF. Unplug and empty the machine of liquid. Tilt the machine back and remove lint with a bent hanger.

LACK OF WATER PRESSURE

- 1) Make sure the cleaning solution was poured from the removable bucket into the solution tank.
- 2) Make sure to pull the spray/brush trigger switch while carpet cleaning; or the hand tool switch is ON when using the hand tool.
- 3) Check to see if the solution hose is connected at the back of the machine.
- 4) Make sure you are not out of cleaning solution.

NO BRUSH MOVEMENT

- 1) Pull the spray/brush trigger switch. If there is no movement, release trigger and check to see if the brush spins freely. Remove any lint and string caught on the brush. Reset the circuit breaker located on the Handle. **DO NOT** attempt to reset circuit breaker if it trips a second time. Have a qualified repair center check/repair the equipment.
- 2) If the motor runs and the brush will not spin (but it can be turned freely by hand), the belt needs to be replaced. See C-4 repair instructions for further details.

KENT INVESTMENT CORPORATION LIMITED WARRANTY

Kent Investment Corporation (the "Company") warrants each new machine against defects in material and workmanship under normal use and service for a period of six months from date of purchase. Our obligation under this warranty is limited to the making good at our factory or authorized distributor service station any part or parts thereof, except motors and pumps (see exception below), which within the warranty period are returned to our factory or authorized distributor service station, transportation prepaid, and which are determined by us to have been defective in workmanship or material. All parts being returned must be accompanied by date of purchase, name of party purchased from, invoice number and serial number of machine. Purchaser's exclusive remedy against defects in workmanship or material under this warranty shall be the repair or replacement of the returned part or parts as set forth above.

EXCEPTION: This warranty does not apply to motors or pumps used on Kent Investment machines. The motors and pumps carry a warranty of their own and are covered by the manufacturer of said motors and pumps.

This limited warranty does not cover any product or part(s), damage or defects resulting from misuse, neglect, accident, normal expected wear, improper installation or operation contrary to factory recommendations or unapproved, unauthorized repairs or alterations. Kent Investment Corporation reserves the right to inspect and make the final decisions on any warranty claims that may be questionable.

Purchaser shall have no claim against the company in connection with this warranty, the company's machines, or otherwise, for consequential or incidental damages, including without limitation damages for loss of use, lost profits, or delayed delivery or expenses related to the receipt, transportation, or care of a new machine. In no event shall the company's liability with respect to each machine covered under this warranty exceed the price paid by purchaser for such machine.

This limited warranty is the exclusive warranty of Kent Investment Corporation and is in lieu of any other warranty express or implied, including, but not limited to, warranties of merchantability and fitness for a particular purpose.

RETURNING THE C-4 TO RENTABLE CONDITION AFTER EACH USE.

- 1) Examine the power cord, plug and switches for damage or wear. Wipe down power cord. (Note: Damaged or worn electrical components must be replaced.)
- 2) Turn on the vacuum motor, let it run to blow out any trapped water. (Note: Unusual motor noise indicates motor needs replacing.)
- 3) Pull spray/brush switch to activate pump and brush. Make sure both are working properly. (Note: Pump should not be run dry more than a few seconds, it becomes loud when dry.)
- 4) Drain all unused solution from the solution tank by lowering the drain hose.
- 5) Remove bucket and spray it inside and out with cleaning disinfectant. Let sit.
- 6) Wipe debris from lid filter screen. (Located on the underside of lid.)
- 7) Clean solution tank filter bag. Pull the tab at the bottom of the bag to turn it inside-out and wipe away debris.
- 8) Spray the outside of the machine with cleaning disinfectant. (Note: Do not spray air vents on the back door, control panel on the handle or any electrical components.)
- 9) Tilt machine forward. Remove hair and debris from brush. Clean vacuum nozzle with lint hook. Ensure wheels are clean.
- 10) Turn the brush by hand to ensure it turns freely. (Note: If brush does not turn freely, remove brush and clean between brush and bearings. Also inspect bearings.) See Servicing and Rebuilding Brush Assembly.
- 11) Wipe machine and rinse bucket. (Note: Do not spray the air vents on the back door, control panel on the handle or any electrical components.)
- 12) Using shop towels and disinfectant, wipe down the entire machine and hoses.
- 13) Keep the bucket ventilated between rents by laying the bucket handle underneath the lid to prevent the lid from closing.
- 14) Check that all decals, instructions and safety warnings are in place and in good condition.
- 15) Inspect and clean the hand tool kit. Pull the hand tool trigger to drain the valve and solution hose.

6 MONTH INSPECTION AND SERVICE

- 1) Service the brush assembly. See Servicing and Rebuilding Brush Assembly, Page 14.
- 2) Check lid for leaks. See testing Lid (7LIDL) Page 16.
- 3) Check coupler (10037) for leaks. Add water to tank. Make sure coupler and brass plug (10038) are connected. Turn on hand tool switch and inspect connection for leaks. Disconnect coupler and plug. Turn on hand tool switch and check coupler for leaks. If leaking see Coupler Repair (4059) Page 16.
- 4) Check spray pattern. Add water to tank. Lean machine back and pull the trigger switch. With your hand, check the spray pattern making sure pattern is uniform. If it is not, the spray jets need to be cleaned.
- 5) Inspect power cord for cuts, scrapes and exposed wires. Also, check the plug for loose prongs.
- 6) Inspect drain tube assembly for leaks. Add water to the tank. If leaks are observed see Replacing Drain Tube (#10159) Page 16.

SERVICE WARNINGS

Warning: Only genuine Kent Investment Corp. electrical replacement parts should be used. Failure to do so will void the UL and CSA electrical safety compliance and could result in fire, electrical shock, personal injury or damage to the model C-4.

Warning: 1. Do not tilt machine all the way back to floor with water in bucket. Water will go through lid, down to vacuum motor and may damage the vacuum motor.
2. If this happens return unit upright and place towel under exhaust port. Turn on the Suction Switch, run until no water discharges out of exhaust port, about 2 to 3 minutes.

Warning: Pump should not run dry for more than a few seconds. Running the pump dry may cause the pump to overheat.

TROUBLE SHOOTING GUIDE

ELECTRICAL SYSTEM

NOTE: When replacing electric terminals a good crimp is essential. Double check new crimp. It should not have exposed wires.

SYMPTOM	POSSIBLE CAUSE	SOLUTION
No power to the machine.	1. Building circuit breaker tripped.	1. Unplug any other equipment on the same circuit. Wait five minutes, reset circuit. Note: If breaker continues to trip, try outlets on another circuit. If new circuit continues to trip, DO NOT use the unit. All motors and wires must be examined for defect.
	2. Defective wall outlet.	2. Plug machine into different outlet. Also: Check if outlet is wired to a light switch.
	3. Defective <i>Plug</i> .	3. Replace <i>Plug (10109)</i> .
	4. Loose Power Connection.	4. Check <i>Lever Nuts (10267 / 10277)</i> to black and white wires.
	5. Defective <i>Power Cord</i> .	5. Replace <i>Power Cord (18205)</i> .
Power is intermittent to all or some of the motors.	1. Loose <i>Terminal</i> or <i>Lever Nut</i> .	1. Replace loose <i>Terminals</i> or reconnect <i>Lever Nut</i> .
	2. Burned or corroded <i>Terminals</i> .	2. Replace <i>Terminals</i> .
	3. Defective <i>Switch</i> .	3. Replace <i>Switch (10308/18032)</i> .
	4. Defective <i>Wire</i> or <i>Power Cord</i> .	4. Replace <i>Wire</i> or <i>Power Cord (18205)</i> .
Electrical short.	1. Damaged or loose wire connection that touches any metal on the machine.	1. Check for damaged or loose wires and make sure all ground wires are properly connected.
	2. Defective motor touching improperly grounded metal on the machine.	2. Replace defective motor and make sure all ground wires are properly connected.
	3. <i>Wire, Power Cord</i> or <i>Terminal</i> with worn insulation.	3. Replace <i>Wire, Power Cord</i> or <i>Terminal</i> .

VACUUM SYSTEM

SYMPTOM	POSSIBLE CAUSE	SOLUTION
Vacuum motor is running with little or no vacuum to floor nozzle or hand tool nozzle.	1. <i>Lid</i> is not secure.	1. Secure <i>Lid</i> (7LIDL) with <i>Bucket Handle</i> (10086).
	2. Defective or missing <i>Lid Gasket</i> .	2. Replace <i>Gasket</i> .(10232)
	3. Accessory hoses at back of the machine are not connected.	3. Connect <i>Black</i> (10077) and <i>Gray</i> (10075) <i>Hose Cuffs</i> .
	4. Debris blockage on <i>Lid Filter Screen</i> or <i>Sight Tubes</i> .	4. Clean <i>Lid Plate Screen</i> (10609), and <i>Sight Tubes</i> (10377).
	5. Blockage in <i>Vacuum Hose</i> or <i>Vacuum Nozzle</i> . NOTE: If <i>Vacuum Nozzle</i> plugs repeatedly, the <i>Vacuum Hose</i> (10256) may be over threaded into the <i>Vacuum Nozzle</i> . Remove <i>Vacuum Hose</i> and rethread into <i>Vacuum Nozzle</i> without over threading.	5. First check vacuum at the accessory hook up at back of unit. If there is good suction at <i>Gray Cuff</i> (10075) then the block is between the <i>Black Cuff</i> (10077) and floor <i>Vacuum Nozzle</i> or <i>Hand Tool Nozzle</i> . Clean <i>Nozzle</i> using lint hook. Clean <i>Vacuum Hose</i> using water, compressed air or a hand held pipe snake. NOTE: <i>Vacuum Nozzle</i> should be cleaned with a lint hook regularly. If suction is poor at <i>Gray Cuff</i> , the block is between the <i>Cuff</i> and <i>Lid</i> or <i>Lid</i> and <i>Duct</i> (10073).
	6. Loose <i>Vacuum Cuffs</i> .	6. Tighten <i>Vacuum Cuffs</i> . Check if threads are sealed with silicone. NOTE: DO NOT over tighten. This may cause <i>Vacuum Hose</i> to partially block <i>Vacuum Cuff</i> , catching debris and blocking vacuum. ALSO: Wipe off any excess silicone squeezed into hose.
	7. Hole in <i>Vacuum Hose</i> .	7. If small, patch. If large, replace <i>Vacuum Hose</i> .
	8. Damaged or missing <i>Front</i> (10031) / <i>Rear</i> (10002) <i>Nozzle Clips</i> .	8. Replace <i>Nozzle Clips</i> . (See Repair Manual: <i>Replacing Front / Rear Nozzle Clips</i>).

VACUUM SYSTEM CONTINUED

SYMPTOM	POSSIBLE CAUSE	SOLUTION
Excessive <i>Vacuum Motor</i> noise.	1. Worn <i>Vacuum Motor</i> bearings and / or fan blades.	1. Replace <i>Vacuum Motor</i> . (18007) (See <i>Repair Manual: Removing Vacuum and Brush Assembly, and Replacing Vacuum Motor.</i>)
Burned motor smell from clean air exhaust.	1. Worn <i>Vacuum Motor</i> brushes. NOTE: Excessive sparking may also occur.	1. Replace <i>Vacuum Motor</i> (18007). (See <i>Repair Manual: Removing Vacuum and Brush Assembly, and Replacing Vacuum Motor.</i>)
All switches are ON, only <i>Vacuum Motor</i> does not run.	1. Defective <i>Vacuum Motor</i> .	1. TEST: Test <i>Vacuum Motor</i> (18007) using <i>Vacuum / Brush Motor Test Cable</i> (7202). If motor runs, there is a problem with the electrical system. NOTE: If motor does not work, replace <i>Vacuum Motor</i> (18007). (See <i>Repair Manual: Removing Vacuum and Brush Assembly, and Replacing Vacuum Motor.</i>)
	2. Defective <i>Switch</i> .	2. Replace <i>Switch</i> (10308).
	3. <i>Terminals</i> not connected or defective.	3. Re-connect or replace <i>Terminals</i> .
Dirty liquid is being discharged through the <i>Vacuum Motor Exhaust Tube</i> (10608). NOTE: The solution is being sucked into the <i>Vacuum Motor</i> and then blowing out the <i>Exhaust Tube</i> . CLEAN UP Step 1: Sit the <i>Bucket</i> aside. Move the machine to concrete surface, such as the garage. Leave the <i>Lid</i> up. Run the <i>Vacuum Motor</i> only for 1 minute to blow out any remaining liquid. Step 2: Clean the discharged dirty liquid from carpet <i>immediately!</i> <i>Spot Remover</i> or <i>7 in 1</i> may be needed. ALSO: Using the <i>Hand Tool</i> may lift spot better.	1. The cleaning solution was not poured from the <i>Bucket</i> into the <i>Solution Tank</i> .	1. Pour the cleaning solution from the <i>Bucket</i> into the <i>Solution Tank</i> .
	2. Foam is building up in the <i>Bucket</i> .	2. Empty <i>Bucket</i> without refilling the <i>Solution Tank</i> .
	3. Too much liquid was added to the <i>Solution Tank</i> .	3. Empty <i>Bucket</i> without refilling the <i>Solution Tank</i> . Do not exceed top Fill Line of <i>Bucket</i> . Add less water to the <i>Solution Tank</i> during next cleaning cycle.

PUMP SYSTEM		
SYMPTOM	POSSIBLE CAUSE	SOLUTION
<p><i>Pump (18006)</i> running (quietly or weak), with no or very little pressure to floor or hand tool spray tips.</p>	<p>1. Defective <i>Diode</i>. NOTE: The <i>Diode</i> controls which direction the piston pumps. If the <i>Diode</i> is defective, even a new <i>Pump</i> will not work.</p>	<p>1. TEST: Test the <i>Pump</i> using the <i>Pump Motor Test Cable (7201)</i>. If the <i>Pump</i> runs normally, replace the <i>Diode Assembly (10409)</i>. The <i>Diode Assembly</i> is the Black Wire connected to the <i>Pump</i> and brown wire next to the yellow wire on the <i>8 Wire Cable Assembly (18206)</i>. NOTE: Use only the <i>Pump Test Cable (7201)</i> to test the <i>Pump</i>. There is a <i>Diode</i> inline on this cable. ALSO: Over time the test <i>Diode</i> may need replacing.</p>
<p><i>Pump</i> running at full strength, very little or no pressure to floor or hand tool spray tips.</p>	<p>1. Empty <i>Solution Tank</i>. Check if cleaning solution is still in removable <i>Bucket</i>. This is a most common mistake. The solution must be poured from the <i>Bucket</i> into the <i>Solution Tank</i>.</p>	<p>1. Pour solution from the <i>Bucket</i> into the <i>Solution Tank</i>.</p>
<p><i>Pump</i> running at full strength, very little or no pressure to floor or hand tool spray tips.</p>	<p>2. <i>Plug</i> is not connected to the <i>Brass Coupler</i>. NOTE: <i>Plug</i> may only appear to be connected to the <i>Coupler</i>.</p>	<p>2. Pull down on the middle of the <i>Coupler (10037)</i> sleeve. Without letting up on sleeve, insert the <i>Plug (10038)</i>. Release the coupler sleeve. The sleeve must snap back into position. Give the hose a tug to ensure connection.</p>
<p><i>Pump</i> running at full strength, very little or no pressure to floor or hand tool spray tips.</p>	<p>3. Clogged <i>Pump Filter</i>.</p>	<p>3. Clean the <i>Pump Filter (10044)</i>. <i>Filter</i> is threaded to the <i>45D Brass Elbow (18211)</i> connecting the <i>Pump</i> to the <i>Solution Tank</i>. NOTE: Reinstall the <i>45D Elbow</i> and <i>Filter</i> carefully to avoid cross threading the <i>Solution Tank</i>. Apply new Teflon Tape to <i>Elbow Threads</i> prior to reinstalling to avoid leaking.</p>
<p><i>Pump</i> running at full strength, very little or no pressure to floor or hand tool spray tips.</p>	<p>4. Clogged <i>Spray Tips</i>.</p>	<p>4. Remove and clean <i>Spray Tips (10242)</i>.</p>

PUMP SYSTEM CONTINUED

SYMPTOM	POSSIBLE CAUSE	SOLUTION
<i>Trigger Switch or Hand Tool Switch are activated and Pump DOES NOT run.</i>	1. Loose <i>Wire or Terminal</i> connection. Or Defective <i>Switch or Terminal</i> .	1. Test: Test <i>Pump</i> using <i>Pump Motor Test Cable (7201)</i> . If <i>Pump</i> runs, there is a problem with electrical system. Look for a loose <i>Wire or Terminal</i> connection. Or replace <i>Trigger Switch (18032)</i> , <i>Hand Tool Switch (10308)</i> , <i>Diode Assembly (10409)</i> , <i>Lever Nut (10267 / 10277)</i> or <i>Spade Terminals (10119)</i> . If the <i>Pump</i> does not run, replace. (See <i>Repair Manual: Replacing the Pump Motor.</i>)
<i>Pump runs continuously.</i>	1. <i>Hand Tool Switch</i> is on during carpet cleaning.	1. Turn off <i>Hand Tool Switch</i> . NOTE: <i>Hand tool Switch</i> must be off during carpet cleaning.
	2. Defective <i>Trigger Switch</i> . NOTE: A defective <i>Trigger Switch</i> will run <i>Pump</i> continuously but may operate <i>Brush Motor</i> normally.	2. Replace <i>Trigger Switch (18032)</i> .
	3. Stuck <i>Trigger Switch</i> .	3. Plastic around <i>Trigger Switch</i> may need to be trimmed.

BRUSH SYSTEM

SYMPTOM	POSSIBLE CAUSE	SOLUTION
<i>Brush will not turn when Trigger Switch is activated, but will turn freely by hand.</i>	1. Defective <i>Trigger Switch</i> . NOTE: A defective <i>Trigger Switch</i> will NOT run the <i>Brush Motor</i> but may operate the <i>Pump</i> normally.	1. Test: Inspect <i>Terminals</i> . Test <i>Brush Motor (18005)</i> using <i>Vacuum/Brush Motor Test Cable (7202)</i> . If the motor runs there is a problem with the electrical system. Look for a loose <i>Wire or Terminal</i> connection. Or replace the <i>Trigger Switch (18032)</i> or <i>Spade Terminals</i> . If <i>Brush Motor</i> does not run, replace. (See <i>Repair Manual: Removing Vacuum and Brush Assembly, and Replacing Brush Motor</i>).

BRUSH SYSTEM CONTINUED

SYMPTOM	POSSIBLE CAUSE	SOLUTION
<i>Brush will not turn when Trigger Switch is activated, but will turn freely by hand.</i>	2. <i>Brush Motor Circuit Breaker</i> has tripped.	2. Insure that <i>Brush (10013)</i> turns freely by hand. Reset <i>Circuit Breaker (10113)</i> . NOTE: If <i>Brush</i> does not turn freely by hand inspect <i>Brush Assembly (18210)</i> . (See <i>Repair Manual: Removing Brush Assembly, and Rebuilding Brush Assembly</i>).
	3. Loose <i>Wire, Lever Nut</i> or <i>Terminal</i> connection.	3. Reconnect loose <i>Lever Nut (10267 / 10277)</i> or replace <i>Spade Terminal</i> .
	4. Broken <i>Gear Belt</i> .	5. Replace <i>Gear Belt (10011)</i> .
	5. Slipping <i>Pulley (10010)</i> .	6. Reattach <i>Pulley (10010)</i> to <i>Brush Shaft (10012)</i> ensuring set screws and dimples in <i>Brush Shaft (10012)</i> align.
<i>Brush will NOT turn when Trigger Switch is activated and will not turn by hand.</i>	1. Debris clogging <i>Bearing Assy / seized Bearings</i> .	1. Remove <i>Brush Assembly (18210)</i> Clean/replace: <i>Bearings (10017)</i> , <i>Bearing Block (10195)</i> , <i>Brush Washer (10183)</i> .
	2. Seized <i>Brush Motor</i> .	2. Replace <i>Brush Motor (18005)</i> . Also inspect <i>Brush Assembly (18210)</i> .
<i>Brush Motor</i> runs continuously.	1. Defective <i>Trigger Switch</i> . NOTE: A defective <i>Trigger Switch</i> will run <i>Brush Motor</i> continuously but may operate the <i>Pump</i> normally.	1. Replace the <i>Trigger Switch (18032)</i> .

REPAIR MANUAL

Warning: Only genuine Kent Investment Corp. electrical replacement parts should be used. Failure to do so will void the UL and CSA electrical safety compliance and could result in fire, electrical shock, personal injury or damage to the model C-4.

REMOVE THE VACUUM AND BRUSH ASSEMBLIES

1. Turn all Switches OFF and UNPLUG the unit.
2. Remove Door (10606). Using a #2 Phillips Screwdriver remove (4) 10-24 Bolts (10150) attaching Door to Solution Tank.
3. Disconnect the (2) Blue Wires marked "V", (2) Red Wires marked "B" and (3) Green (Ground) Wires.
4. Using a 5/16 Nut Driver unscrew the Duct Clamp (10071) then disconnect the Duct Cuff (10077).
5. Remove the Exhaust Tube (10608).
6. Disconnect the Brass Plug (10038) and Coupler (10037) and Vacuum Cuffs (10075 / 10077).
7. Remove the Brush and Vacuum Assemblies. Using a #2 Phillips Screwdriver remove (3) 10-24 Bolts (10150) and using 3/8 Nut Driver remove the (1) 10-24 Nut (10273) attaching the Brush Assembly to the Solution Tank. Next using a #3 Screwdriver remove the (4) 1/4-20 Bolts (10178), remove the Duct Strap (10076). Next lift the Brush Assembly up to clear the Stud (10187) then lay the Brush Assembly forward. Lift the Vacuum Motor Assembly out of the unit. Now the Brush Assembly can also be removed.

NOTE: Re-silicone the inner surface to the Exhaust Tube (10608) that touches the Vacuum Motor (18007) Exhaust Port before reassembling the unit.

REPLACE THE VACUUM MOTOR (18007)

1. Turn all Switches OFF and UNPLUG the unit.
2. See (Removing Vacuum and Brush Assembly).
3. Remove the Vacuum Motor (18007) from the Duct (10073). Using 2 Wrenches with 7/16 Sockets unscrew the (3) 1/4-20 Nuts (10137) and 1/4-20 Bolts (10063).

NOTE: When reassembling the Vac Motor Assembly make sure the washers are replaced in the correct location. (See Parts Diagram)

NOTE: Do not over tighten the Nuts (10137). This may result in cracking the Vacuum Motor.

NOTE: Inspect all Wires, Terminals and Hoses for damage before reassembling unit.

NOTE: Before reassembling the unit, all components should be cleaned.

NOTE: While the unit is apart the Brush Assembly should be inspected.

NOTE: Ensure Ground (Green) Wires are reconnected.

REPLACING THE BRUSH MOTOR (18005)

1. Turn all Switches OFF and UNPLUG the unit.
2. See (Removing Vacuum and Brush Assembly).
3. Disconnect the Brush Motor (18005) Ground (Green) Wire. Using a 5/16 Nut Driver remove (1) 10-32 Bolt (10152), from the Housing Brush (10001).
4. Using 5/16 Nut Driver remove the top (2) 10-24 Bolts (10182) holding down the (2) Brush Motor Straps (10008).

NOTE: Do not remove the bottom (2) Bolts holding down the Brush Motor Straps.

5. Bend both Straps up. Tilt the pulley side of the Brush Motor down to slip Pulley out from under the Belt (10011).

NOTE: While the Brush Motor is out, inspect the Belt (10011) and Bearing Assemblies (18016). Remove any hair or dirt. (See Rebuilding Brush Assembly).

NOTE: Show extra care when threading bolts into the Brush Housing, to avoid cross threading.

NOTE: Inspect all Wires, Terminals and Hoses for damage before reassembling unit.

NOTE: Before reassembling the unit all components should be cleaned.

NOTE: Ensure Green (Ground) Wires are reconnected.

REPLACING THE PUMP MOTOR (18006)

1. Turn all Switches OFF and UNPLUG the unit.
2. Remove the Door (10606). Using a #2 Phillips Screwdriver remove (4) 10-24 Bolts (10150) attaching the Door to the Solution Tank.
3. Disconnect the Yellow Wire marked "P", Brown Wire and Green (Ground) Wire.
4. Loosen the 5/8" Clamp (10329) that connects the Solution Hose (10238) to the Brass Elbow (18211) using a 1/4" Nut Driver.
5. Install new Pump Assembly (4PUMA).

NOTE: Ensure Ground (Green) Wire is reconnected.

NOTE: Inspect all Wires, Terminals and Hoses for damage before reassembling unit.

REMOVING THE BRUSH ASSEMBLY (18210)

1. Remove Belt Cover (10100). Using a #2 Phillips Screwdriver remove (2) 6-32 Bolts (10026/10230).
2. Disconnect Belt (10011) from Pulley (10009). With thumb and index finger pull Belt toward yourself and down, rotating Belt off the Pulley.
3. Remove the Brush Bracket (10016). Using a #2 Phillips Screwdriver remove (1) 10-24 Bolt (10150). Using a 3/8 Nut Driver remove (1) 10-24 Hex Nut (10273)
4. Lift up on the pulley side of the Brush Assembly (18210) to rotate out of the Brush Housing (10001).

SERVICING AND REBUILDING THE BRUSH ASSEMBLY (18210)

1. Remove the Brush Pulley (10010) by removing (2) Set Screws (10276) using a 5/64 Allen Wrench. NOTE: First use a Heat Gun or Torch to expand the Pulley, making it much easier to remove the Set Screws and slide the Pulley off the Shaft (10012). NOTE: When reassembling the Pulley add a drop of light duty thread locker to Set Screws. Align Pulley Set Screws and the Shaft dimples. Without rotating the Pulley, slide it onto the Shaft until only the chamfered edge of the Shaft is sticking through the Pulley. Tighten only (1) Set screw. Turn the Pulley back and forth. The Set Screw should rock in the dimple but it should not rotate. If It rotates, it is not in the dimple and should be reset. Once in dimple, tighten second Set Screw.
2. Remove Bearing Assemblies (18016).
3. Clean and inspect Bearing Assemblies, removing any hair and dirt. **NOTE:** If Bearing (10017), Bearing Block (10195), or Brush Core Washer (10183) are worn or damaged, replace them.
4. Inspect the ends of the Brush Shaft (10012) for dirt or corrosion buildup. Clean with low abrasive emery cloth and oil.
5. Inspect Brush (10013) for wear, replace if necessary.

REPLACING THE FRONT NOZZLE CLIP (10031)

1. Turn all Switches OFF and UNPLUG the unit.
2. Using a #2 Phillips Screwdriver remove (3) 8-32 Bolts (10274) attaching Front Nozzle Clip (10031) to Brush Housing (10001).
3. Remove Front Nozzle Clip from Brush Housing.
4. Scrape away any remaining silicone from the inside of the Brush Housing Vacuum Nozzle.
5. Apply a thin bead of silicone to the new Vacuum Nozzle Clip outer surface that touches the inside of the Brush Housing Vacuum Nozzle.
7. Add a drop of heavy-duty thread locker to the (3) threaded inserts in the Front Nozzle Clip.
8. Thread (3) Bolts into Front Nozzle Clip threaded inserts.
9. Wipe away excess thread locker and silicone from the outside and inside of Vacuum Nozzle.

REPLACING THE REAR NOZZLE CLIP (10002)

1. Turn all switches OFF and UNPLUG the unit.
2. Using a #2 Phillips Screwdriver remove (2) 6-32 Bolts (10004) attaching Rear Nozzle Clip to the Brush Housing (10001).
3. Remove Rear Nozzle Clip (10002) from the Brush Housing.
4. Scrape away any remaining silicone from Brush Housing.
5. Apply a bead of silicone to the inside of new Rear Nozzle Clip.
6. Attach to Brush Housing.
7. Add a drop of light-duty thread locker to 2 threaded holes in Brush Housing.
8. Thread (2) Bolts into Brush Housing. **NOTE:** Be careful not to cross thread Brush Housing.
9. Wipe away any excess thread locker and silicone from the outside and inside of Vacuum Nozzle.

REPLACING THE TRIGGER SWITCH (18032)

1. Turn all switches OFF and UNPLUG the unit.
2. Remove Control Panel (10118). Using a #2 Phillips Screwdriver remove (4) 6-32 Bolts (10026) attaching the Control Panel (10118) to the Handle (10600).
3. Using a 1/4" Nut Driver remove (2) 8-32 Bolts (2037) attaching Trigger Switch (18032) to the Handle.
4. Reaching inside the Handle, pull out the Trigger Switch (18032) while from the outside push the Trigger Switch into the slotted Handle opening.
5. Remove the Wire Ties (10158) and Lever Nuts (10267 / 10277) attached to the Blue and Black Wires. Disconnect the Blue Wire Flag Terminal Connector (10148) from the Circuit Breaker (10113).

NOTE: Ensure wires are firmly seated in the Lever Nuts (10267 / 10277). Bare wires should never be exposed and the Lever Nut should not grip on the wire insulation.

NOTE: Remember to replace the cut Wire Ties.

NOTE: When attaching the Trigger Switch to Handle start threading (2) 8-32 Bolts (2037) into Switch Mount Bracket by hand to avoid cross threading.

REPLACING THE ROCKER SWITCH ASSEMBLY (10308):

1. Turn all switches OFF and UNPLUG the unit.
2. Remove Control Panel (10118). Using a #2 Phillips Screwdriver remove (4) 6-32 Bolts (10026) attaching the Control Panel to the Handle (10600).
3. Depress molded retention springs on either side of the Rocker Switch (10308), while pushing it through the Control Panel opening.
4. Before disconnecting Wire Terminals, take note as to which Rocker Switch Terminal each comes from. Disconnect the Wire Terminals from the old Rocker Switch, and re-connect them to the corresponding new rocker Switch Terminals.
6. Install the new Rocker Switch by pushing it through the switch opening in the Control Panel.

NOTE: Inspect all Wires, and Terminals. Replace any defective components.

NOTE: Remember to replace the cut Wire Ties.

NOTE: Rocker Switches should always have a Rocker Switch Cap. Always replace when missing.

REPLACING TERMINALS

1. Change terminals when burned, melted or discolored. Cut damaged terminal off with wire cutters, cut as little wire as possible. Using wire strippers, strip back insulation 5/16 of an inch. Now put new terminal on wire and crimp down on terminal with wire terminal crimping tool. Inspect crimp making sure no wire is exposed and the terminal is secured to the wire. All terminals should be inspected and changed if necessary when changing out vacuum motors, pumps, brush motors and rocker switches.

WIRING LEVER NUTS

1. If necessary strip 5/16 of an inch of wire insulation from wire with wire strippers. Lift orange lever on Lever Connector. Put wire in Lever Connector hole. Snap down orange lever all the way. Pull on wire to make sure wire is secured in Lever Connector. Make sure no wires are exposed.

COUPLER REPAIR (4059)

1. Using 8 inch Vice Grips clamp the top ribbed or knurled portion of the Coupler; then using a 17 mm Open End Wrench on the lower part of the Coupler twist counter clockwise to loosen.
2. Remove top of Coupler, Rubber Seal, Cone Spring, and keep Valve for reinstallation. Remove Spring from collared portion of the Coupler using a pointed tool. The two pieces will then come apart. Remove any debris that may be in the Coupler.
3. Using a Coupler Repair Kit (4059) replace Ball Bearings and then the Spring (making sure the Spring is inserted all the way.) Then return Valve, and replace Cone Spring and Rubber Seal, and then thread top portion of the Coupler back to the lower portion and tighten. Without inserting the the Brass Plug (10038) into the Coupler run the Pump with water to ensure Coupler does not leak. If Coupler leaks, disassemble and reseal the Valve and Rubber Washer, then test again. **NOTE:** The Valve and Rubber Washer placement is critical to ensure Coupler does not leak.

REPLACING DRAIN TUBE (#10159)

Note: If there is a leak at the Drain it needs to be determined if the leak is between the Drain Tube (10159) and the Drain Cartridge (18015), or the Drain Cartridge and the Solution Tank (18009). If the leak is between the Drain Tube and the Drain Cartridge the Drain Cartridge should not be removed from the Solution Tank.

1. Remove Door (10606). Using #2 Philips Screwdriver remove (4) 10-24 Bolts (#10150) attaching Door to Solution Tank.
2. Remove the O-Ring (10430) from between the Drain Cartridge (18015) chrome flange and brass base. Push in on chrome flange ring on the Drain Cartridge (18015). While pushing in the flange pull Drain Tube (10159) at the same time. The Drain Tube (10159) will release from the Drain Cartridge (18015).
3. If there is a leak between the Drain Cartridge (18015) and the Solution Tank (18020) remove the Drain Cartridge from the Solution Tank by inserting a 5/16" Allen Wrench all the way into the opening of the Drain Cartridge. Turn the Allen Wrench (Clockwise to Counterclockwise) to unthread the Drain Cartridge from the Solution Tank. Clean the Drain Cartridge and Solution Tank threads and apply a good amount of Teflon Tape to the Drain Cartridge threads. Reinstall the Drain Cartridge being extra careful not to cross thread the Solution Tank threads, start the threading by hand before using the wrench.
4. Remove the Drain Insert (18204) and Drain Spring (10429) from the Drain Tube (10159). Cut about 1" off the end of the Drain Tube that was installed in the Drain Cartridge or replace the Drain Tube. Slide the Drain Insert (18204) onto a Small Screwdriver, flange towards handle. Then slide the Drain Spring (10429) onto the screwdriver. Insert the Drain Spring and Drain Insert into Drain Tube (10159) using the screwdriver. Put a new O-ring (10430) on Drain Tube, insert Drain Hose Assembly into Drain Cartridge (18015). Push in hard until brass insert is all the way in the Drain Cartridge.
5. Slide the O-ring (10430) in between chrome flange and brass base of Drain Cartridge, using a little hook tool and 1/8 flat screwdriver.

TESTING LID (7LIDL M)

1. Make sure all Switches (10308 / 18032) are turned OFF. Plug in the machine. Make sure Bucket (10604) is in place and the Lid (7LIDL M) is secured by the Bucket Bail (10086). Disconnect the Grey and Black Vacuum Cuffs (10075 / 10077).
- 2) Turn on the suction and slowly vacuum water from an 8 oz. glass through the Grey Cuff. Water should appear in the right Sight Tube. The left Sight Tube should be dry. If water appears in the left Sight Tube, the Lid may need to be replaced or returned to Kent Investment Inc. for remanufacturing.

Model C4-A Parts List and Diagrams

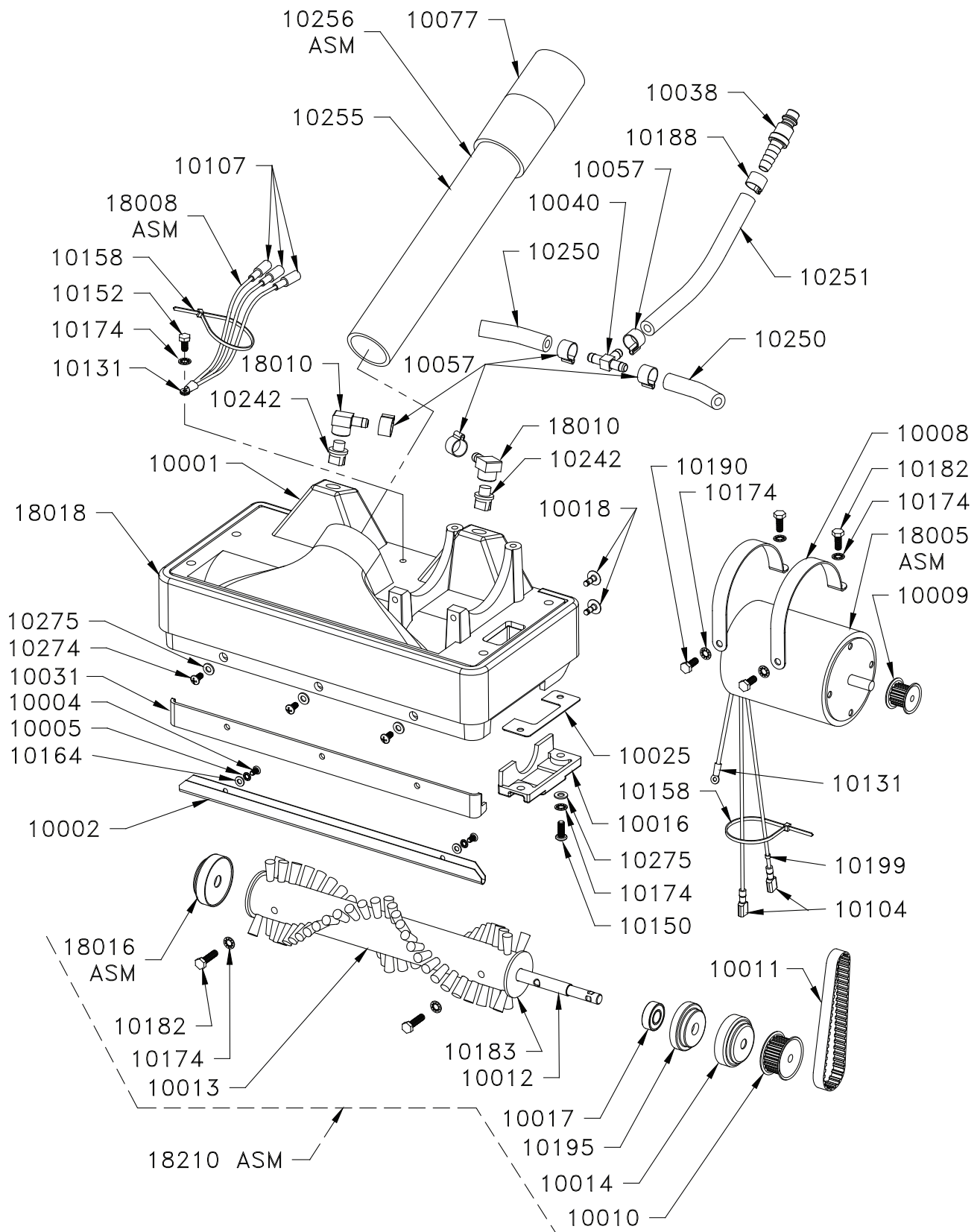

Brush Assembly C4-A

Part #	Description	Qty	Notes
10001	Housing, Brush/Alum. Casting	1 ea	
10002	Clip, Nozzle-Rear	1 ea	
10004	Bolt, 6-32 x 1/4 Phil SS	2 ea	
10005	Washer, Lock #6 SS	2 ea	
10008	Strap, Motor Brush	2 ea	
10009	Pulley, Threaded-Motor	1 ea	
10011	Belt, Gear	1 ea	
10016	Bracket, Brush	1 ea	
10018	Rivet, Alum 5/32 x 1/4	4 ea	
10025	Gasket, 2 Part-Brush/Sw. Panel	1 ea	
10031	Clip, Nozzle-Front	1 ea	
10038	Brass, Plug 1/4 Barb	1 ea	
10040	Brass, T-1/4 x 1/4 x 1/4 Barb	1 ea	
10057	Clamp, 1/4 Sol. Hose-Zinc	5 ea	
10150	Bolt, 10-24 x 1/2 Phil SS	1 ea	
10152	Bolt, 10-32 x 3/8 Hex Ground, Grn	1 ea	
10158	Wire, Tie-6"	2 ea	
10164	Washer, Flat #8 SS	2 ea	
10174	Washer, Lock #10 SS	6 ea	
10182	Bolt, 10-24 x 3/4 Hex SS	2 ea	
10188	Clamp, 1/4 Sol. Hose SS	1 ea	
10190	Bolt, 10-24 x 1/2 Hex SS	2 ea	
10242	Spray Tip, Quick Dry	2 ea	
10250	Hose, Solution-90D Elbow to T - 1/4 I.D. x 2 3/8	2 ea	
10251	Hose, Solution-Plug to T - 1/4 I.D. x 21	1 ea	
10256	Hose, Vac Nozzle to Disconnect with Cuff	1 ea	
10077	Cuff, Hose-Female, Black	1 ea	
10255	Hose, Vac Nozzle to Disconnect 1 1/4 I.D. x 21	1 ea	
10274	Bolt, 8-32 x 5/16 Phil SS	3 ea	
10275	Washer, Flat #10 SS	4 ea	
18005	Motor-Brush Wired C4 115 Volt Assembly	1 ea	
NFS	Motor, Brush C-4 115 Volt, Unwired	1 ea	
10104	Terminal, Spade-Male	2 ea	
10131	Terminal, Ring #10	1 ea	
10199	Tag, Wire B/Brush Motor (C4)	1 ea	
18008	Wire, Ground Housing Brush Assembly	3 ea	
10107	Terminal, Bullet Female-Ground	1 ea	
10131	Terminal, Ring #10	1 ea	
18010	Brass, Elbow 90 D	2 ea	
18018	Bumper, Assembly	1 ea	
18210	Brush Core Sub-Assembly	1 ea	
10010	Pulley, Set Screw-Shaft	1 ea	
10012	Shaft, Brush	1 ea	
10013	Brush, Reel With Flange	1 ea	
10183	Washer, Brush Core	2 ea	
10174	Washer, Lock #10 SS	2 ea	
10182	Bolt, 10-24 x 3/4 Hex SS	2 ea	
18016	Bearing Block Assembly	2 ea	
10014	Bearing, Cap (metal)	1 ea	
10017	Bearing, Ball SS	1 ea	
10195	Bearing, Block (clear rubber)	1 ea	

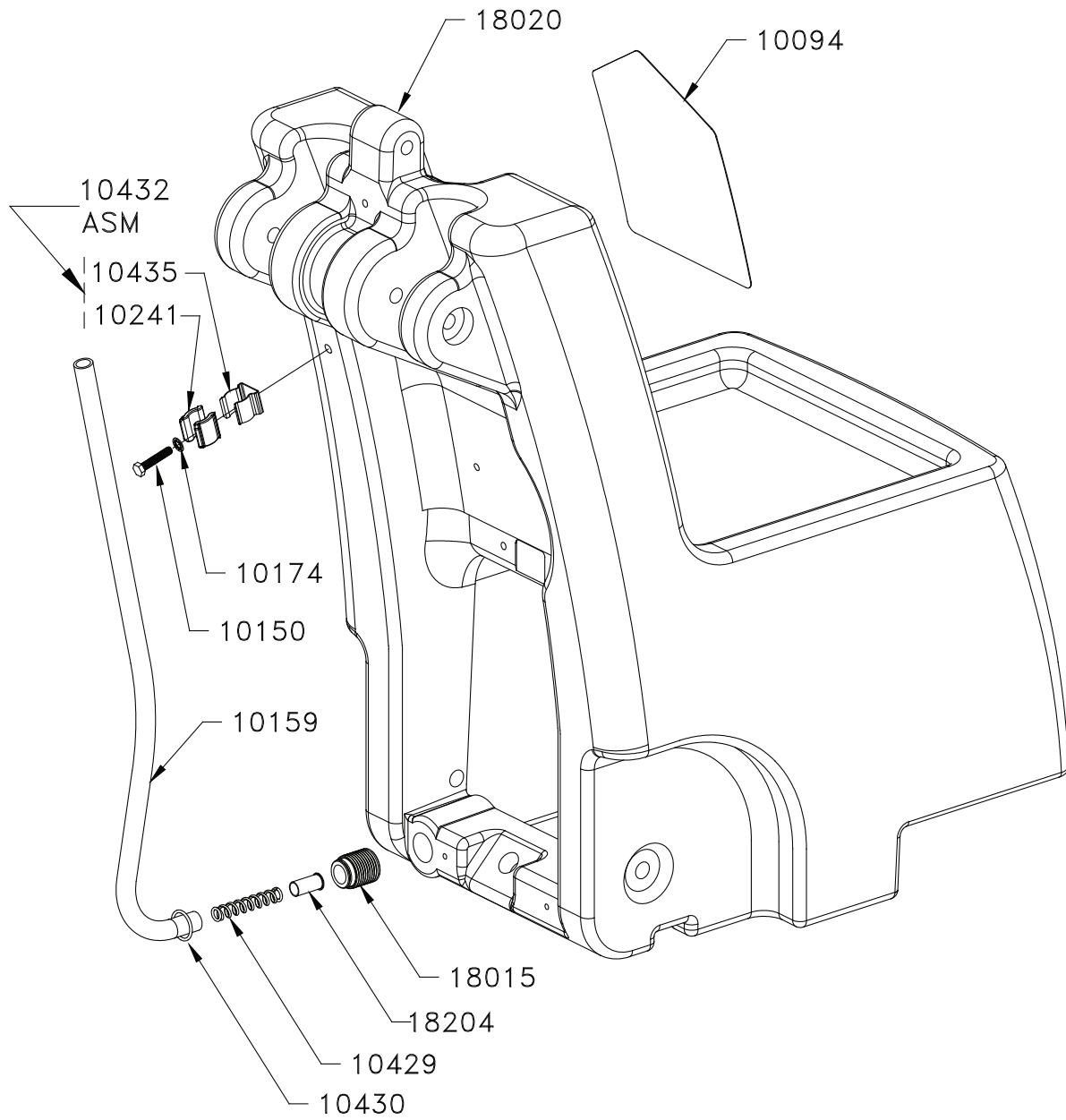

Solution Tank C4-A

Part #	Description	Qty	Notes
18009	Solution Tank, Assembly C4-A	1 ea	
10094	Decal, "Note Pour Here"	1 ea	
16006	Kit, Drain C4-A	1 ea	
10150	Bolt, 10-24 x 1/2 Phil SS	1 ea	
10159	Drain Tube, 3/8 I.D., 1/2 O.D. x 22.5	1 ea	
10174	Washer, Lock #10 SS	1 ea	
10429	Drain, Spring SS C4-A	1 ea	
10430	Drain, O-Ring	1 ea	
10432	Drain, Clip Assembly	1 ea	
10241	Cover, Drain Hose Clip	2 ea	
10435	Drain, Clip	1 ea	
18015	Drain, Threaded Sleeve w/Cart	1 ea	
18204	Drain, Insert, Hose, Brass	1 ea	
18020	Solution Tank, Gray C4-A	1 ea	

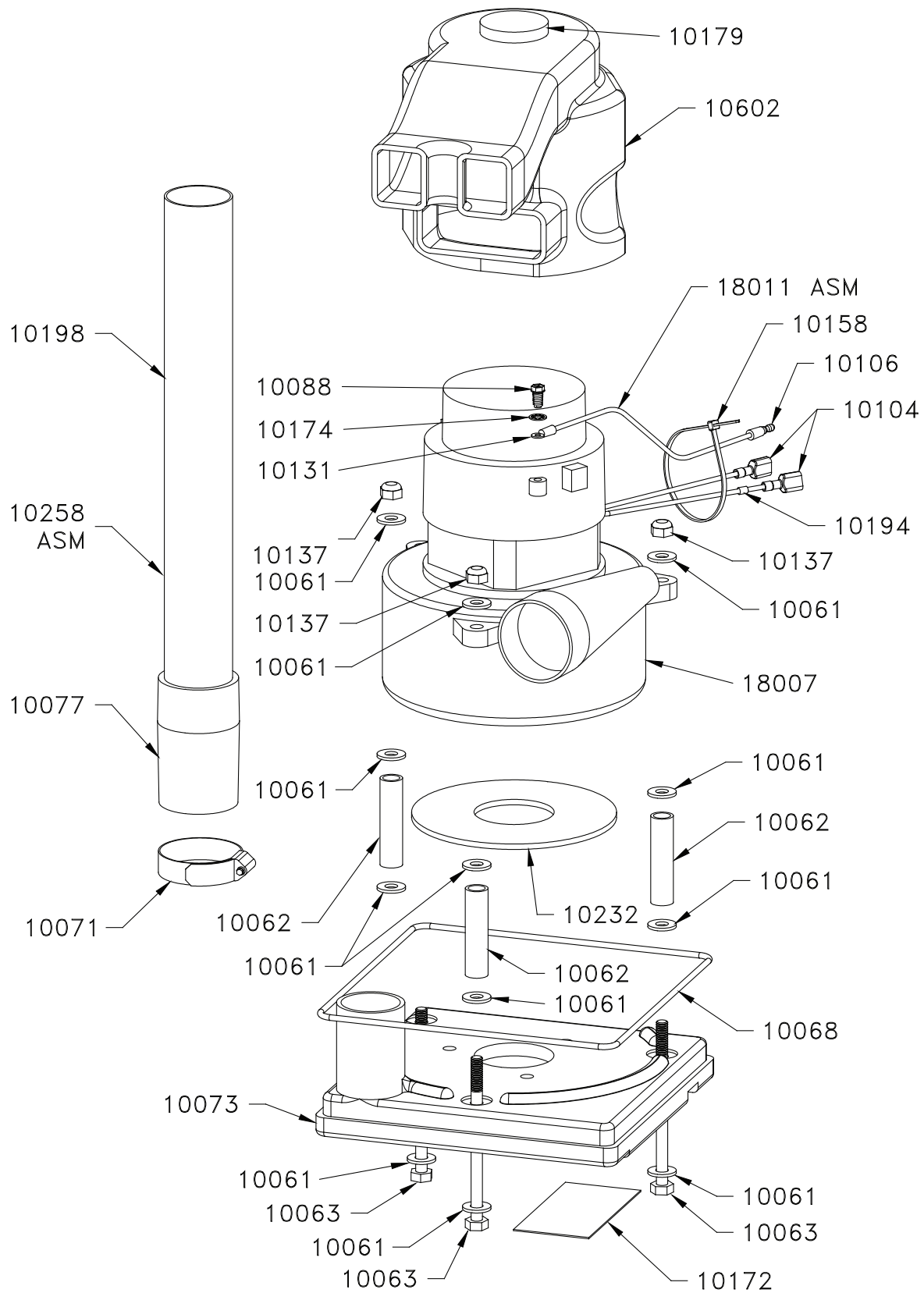

Vacuum Assembly C4-A

Part #	Description	Qty	Notes
10061	Washer, Flat 1/4 SS	12 ea	
10062	Stand-Off, Vac Motor-Alum.	3 ea	
10063	Bolt, 1/4-20 x 3 3/4 Hex SS	3 ea	
10068	O-Ring, Duct	1 ea	
10071	Clamp Gear, Duct-1 3/4 SS	1 ea	
10073	Duct, Vacuum	1 ea	
10137	Nut, 1/4-20 Nylock SS	3 ea	
10172	Decal, Caution-Duct	1 ea	
10179	Gasket, Vacuum Motor Cover 3 X 1/4	1 ea	
10232	Gasket, Lid / Duct-1/4 C4-A	1 ea	
10258	Hose, Vacuum Duct to Lid w/Cuff Assembly	1 ea	
10077	Cuff, Hose-Vac Duct Black	1 ea	
10198	Hose, Vac-Duct to Lid 26	1 ea	
10602	Motor Cover, Vac C4-A	1 ea	
18007	Motor-Vacuum Wired C4 115 Volt Assembly	1 ea	
NFS	Motor, Vacuum-Unwired	1 ea	
10088	Screw, #10 Self Tap Ground Green	1 ea	
10104	Terminal, Spade-Male	2 ea	
10158	Wire, Tie-6"	2 ea	
10174	Washer, Lock #10 SS	1 ea	
10194	Tag, Wire (V) Vacuum Motor	1 ea	
18011	Ground Wire-Motor, Vacuum Assembly	1 ea	
10106	Terminal, Bullet Male-Ground	1 ea	
10131	Terminal, Ring #10	1 ea	

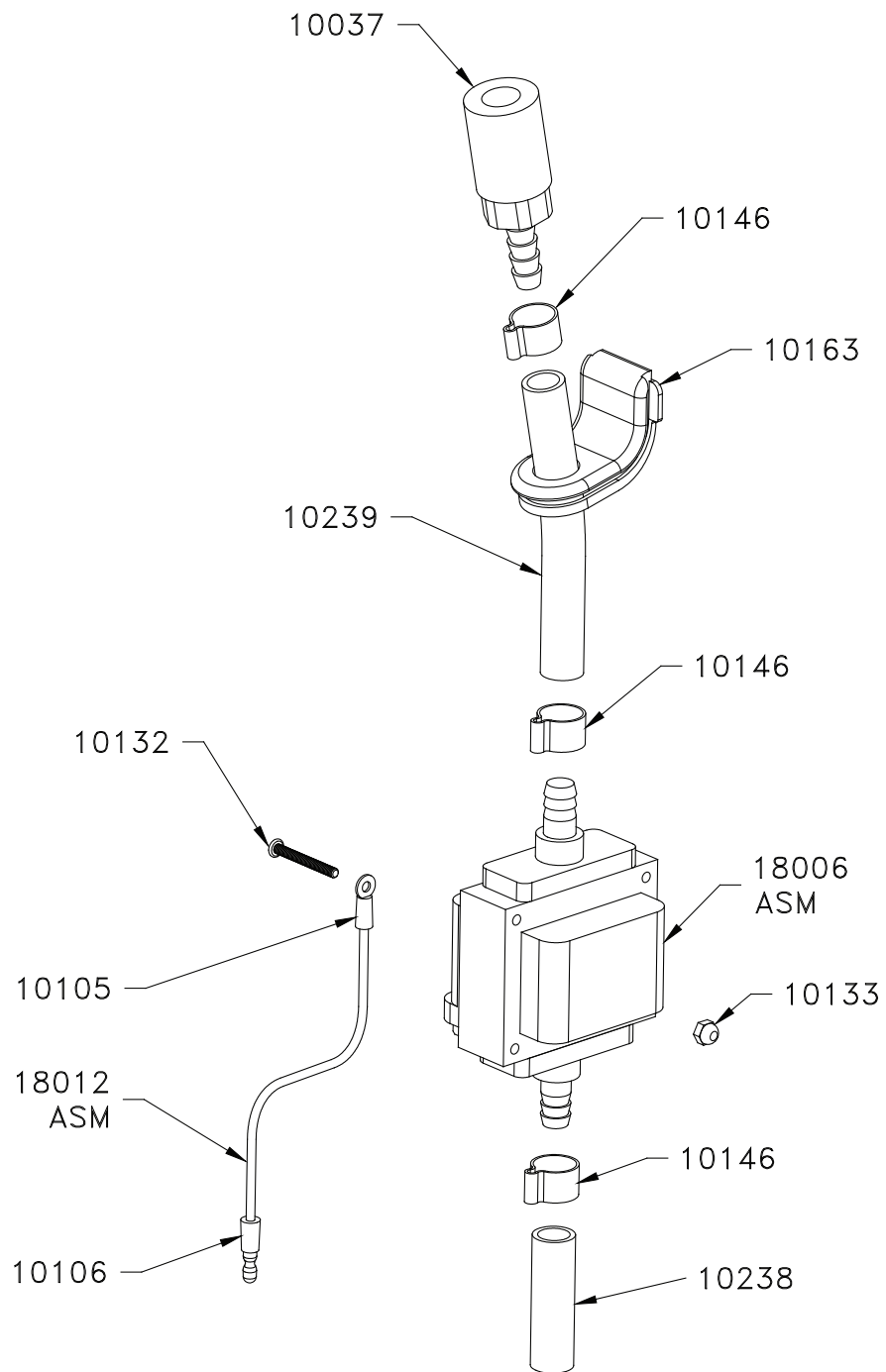

Pump Assembly C4-A

Part #	Description	Qty	Notes	
4PUMA	Pump, Motor Assembly		1 ea	
	10037	Coupler, Brass, 5/16 Barb-Auto	1 ea	
	10146	Clamp, 5/16 Sol. Hose SS	3 ea	
	10163	Grommet, Pump, Door, C4-A	1 ea	
	10238	Hose, Sol. Pump Inlet-1 5/8 C4-A	1 ea	
	10239	Hose, Sol. Pump Outlet-3 3/4 C4-A	1 ea	
	18006	Pump, Motor-Wired		1 ea
		NFS	Pump, Motor	1 ea
	10132	Bolt, 4-40 x 1 Phil SS	1 ea	
	10133	Nut, 4-40 Nylock SS	1 ea	
	18012	Ground, Wire-Pump		1 ea
		10105	Terminal, Ring #4	1 ea
		10106	Terminal, Bullet Male-Ground	1 ea

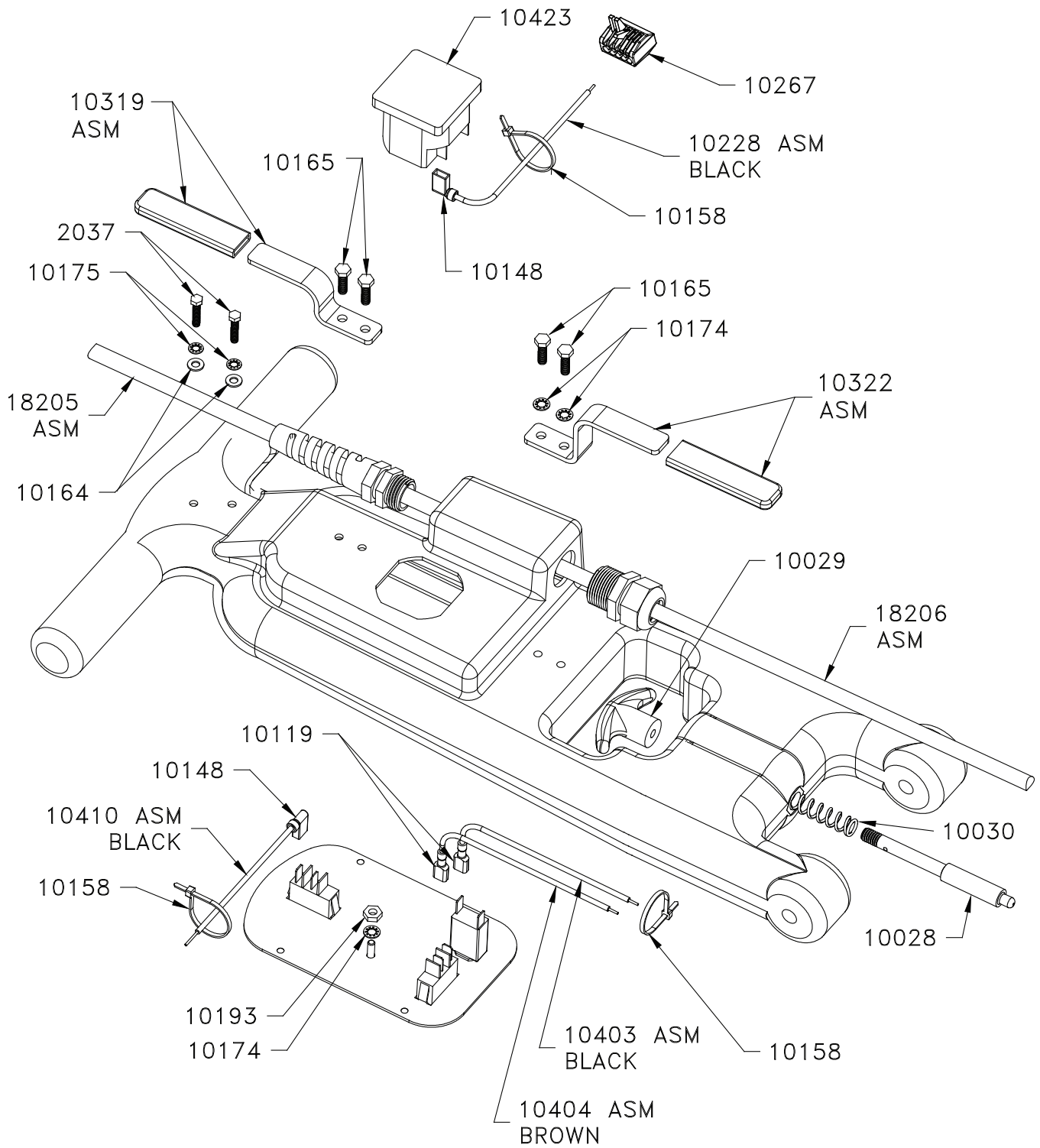

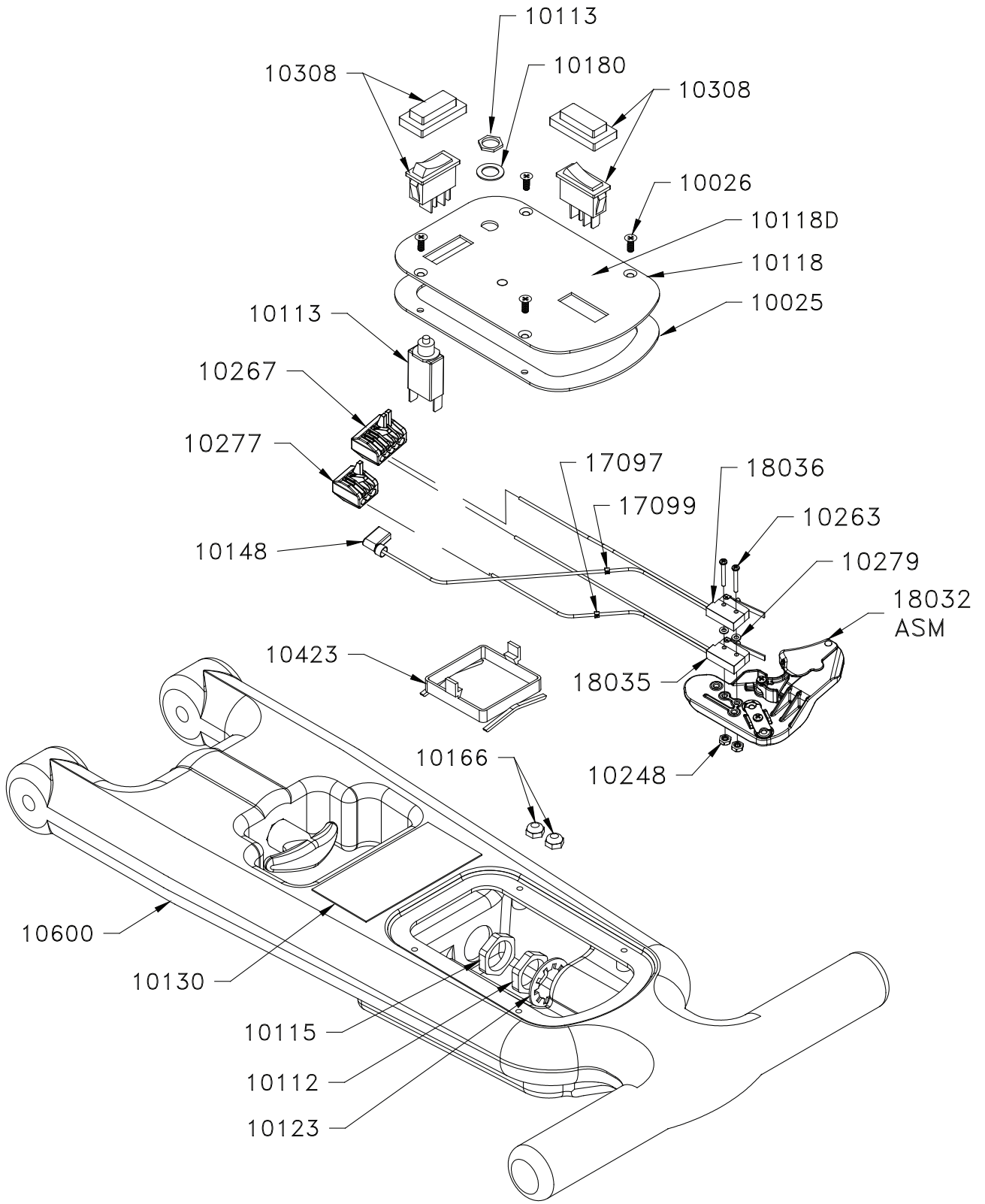

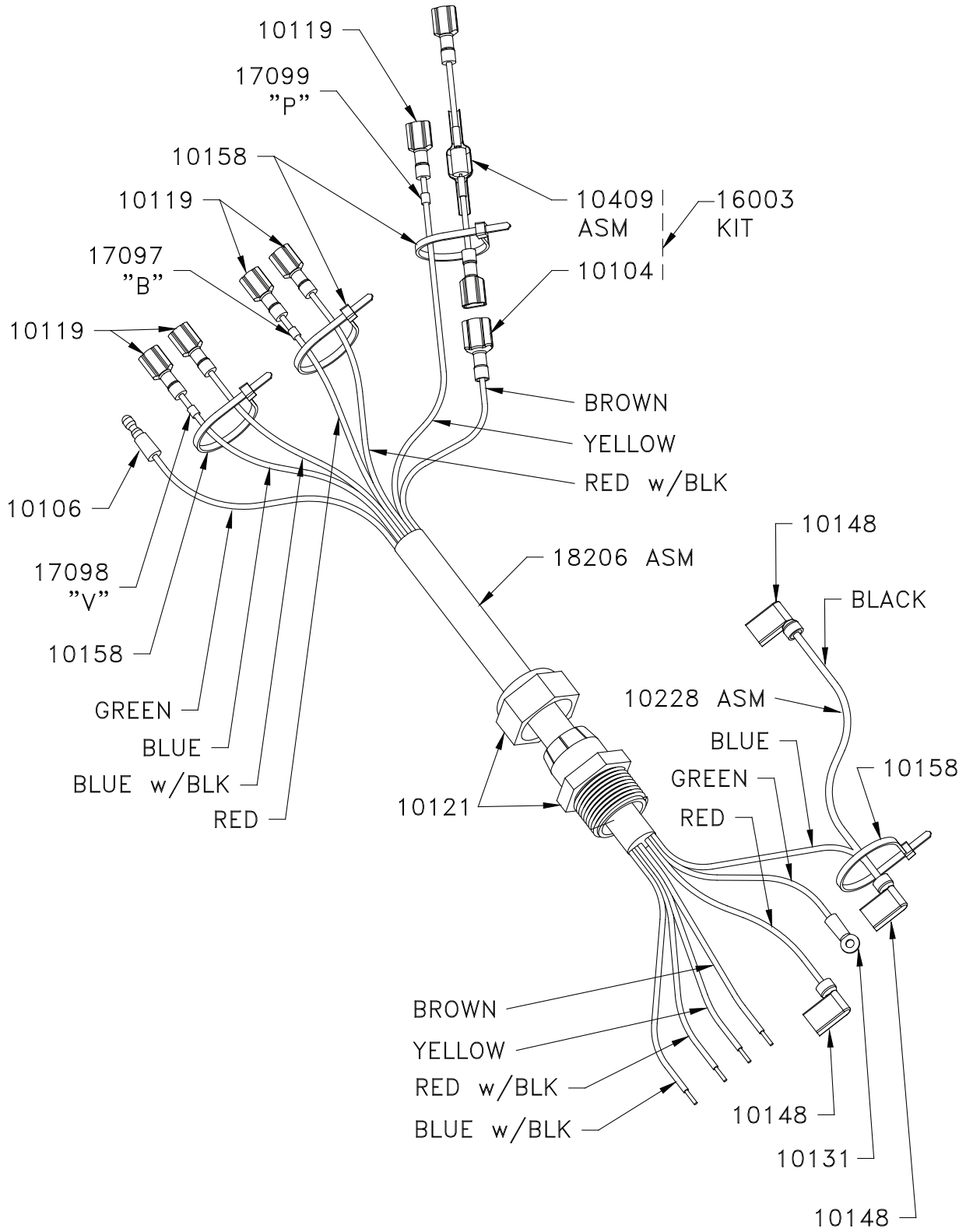

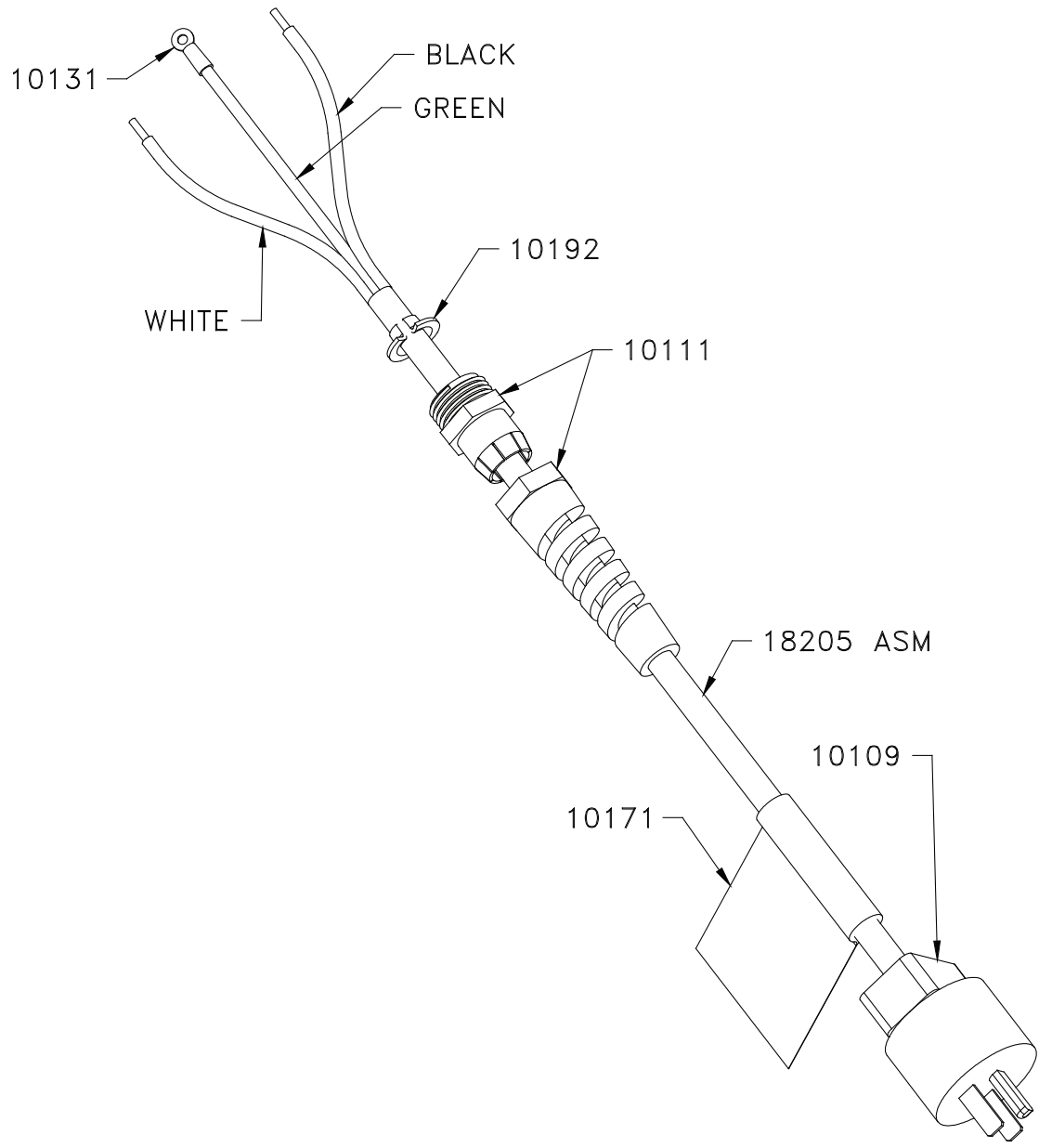

Handle Assembly C4-A

Part #	Description	Qty	Notes
5HAN	Handle Assembly	1 ea	
2037	Bolt, 8-32 x 3/4 Hex SS	2 ea	
10600	Handle, Machine-Gray	1 ea	
10025	Gasket 2 Part-Brush/Sw. Panel	1 ea	
10026	Bolt, 6-32 x 3/8 Phil Flat SS	4 ea	
10028	Shaft, Plunger-Detent	1 ea	
10029	Handle, "T" Detent	1 ea	
10030	Spring, Detent-SS	1 ea	
10111	Strain Relief-Power Cord	1 ea	
10112	Nut, Strain-Relief Power Cord	1 ea	
10113	Circuit Breaker, 120V	1 ea	
10115	Nut, Strain-Relief Cable 8	1 ea	
10118	Control Panel-120V	1 ea	
10118D	Decal, Control Panel	1 ea	
10123	Washer, Lock-3/4	1 ea	
10130	Decal, Handle Adjustment	1 ea	
10148	Terminal, Connector-Flag	1 ea	
10158	Wire Ties-6	4 ea	
10164	Washer, Flat #8 SS	2 ea	
10165	Bolt, 10-24 x 5/8 Hex SS	4 ea	
10166	Nut, 10-24 Nylock SS	2 ea	
10174	Washer, Lock #10 SS	3 ea	
10175	Washer Lock #8	2 ea	
10180	Washer .390 x .625 x .031 SS	1 ea	
10192	Crimp, Strain Relief, Power Cord	1 ea	
10193	Nut, 10-32 Ground-Green	1 ea	
10228	Wire, Black 5" Flag Cntr.-Hour Meter	2 ea	
	10148 Terminal, Connector-Flag	1 ea	
10267	Lever Nut, Five Port	2 ea	
10277	Lever Nut, Three Port	1 ea	
10308	Switch, Rocker w/Cap	2 ea	
10319	Bracket, Cord Wrap-Upper w/ Protector	1 ea	
10322	Bracket, Cord Wrap-Lower w/ Protector	1 ea	
10403	Wire, Black 8" FML Cntr.-H.T.Switch to Lever Nut	1 ea	
	10119 Terminal, Spade Female-18 Gauge	1 ea	
10404	Wire, Brown 8" FML Cntr.-H.T. Switch to Lever Nut	1 ea	
	10119 Terminal, Spade Female-18 Gauge	1 ea	
10410	Wire, Black 8" Flag Cntr.-S. Switch to Lever Nut	1 ea	
	10148 Terminal, Connector-Flag	1 ea	
10423	Hour Meter, Unwired	1 ea	
18205	Cord, Power Assembly Handle	1 ea	
	10109 Plug, Power Cord	1 ea	
	10131 Terminal, Ring #10	1 ea	
	10171 Decal, Warning-Power Cord	1 ea	

Handle Assembly C4-A

Part #	Description	Qty	Notes	
18032	Switch, Trigger Asm	1 ea		
	10148	Terminal, Connector-Flag	1 ea	
	10248	Nut, 2-56 Nylock SS	2 ea	
	10263	Bolt, 2-56 Shoulder SS	2 ea	
	10279	O-Ring, Switch Trigger	2 ea	
	17097	Tag, Wire B	1 ea	
	17099	Tag, Wire P	1 ea	
	18035	Switch, Pump ASM	1 ea	
	18036	Switch, Brush ASM	1 ea	
18206	Cable (8 Wire) Assembly Handle to Motors	1 ea		
	10104	Terminal, Spade Male	1 ea	
	10106	Terminal, Bullet Male, Ground	1 ea	
	10119	Terminal, Spade Female-18 Gauge	5 ea	
	10121	Strain Relief, Cable-Wire 8	1 ea	
	10131	Terminal, Ring #10	1 ea	
	10148	Terminal, Connector-Flag	1 ea	
	10158	Wire, Tie-6"	3 ea	
	17097	Tag, Wire B/8-Wire	1 ea	
	17098	Tag, Wire V/8-Wire	1 ea	
	17099	Tag, Wire P/8-Wire	1 ea	
	10409	Diode Assembly	1 ea	
		10119	Terminal, Spade Female-18 AWG	2 ea
		NFS	Diode	1 ea
		NFS	Parallel, Splice-Uninsulated	2 ea
		NFS	Wire, Black, 1 1/2-Diode	2 ea
		NFS	Heat Shrink, 2	1 ea
16003	Kit, Diode	1 ea		
	10409	Diode Assembly	1 ea	
	10104	Terminal, Spade Male	1 ea	

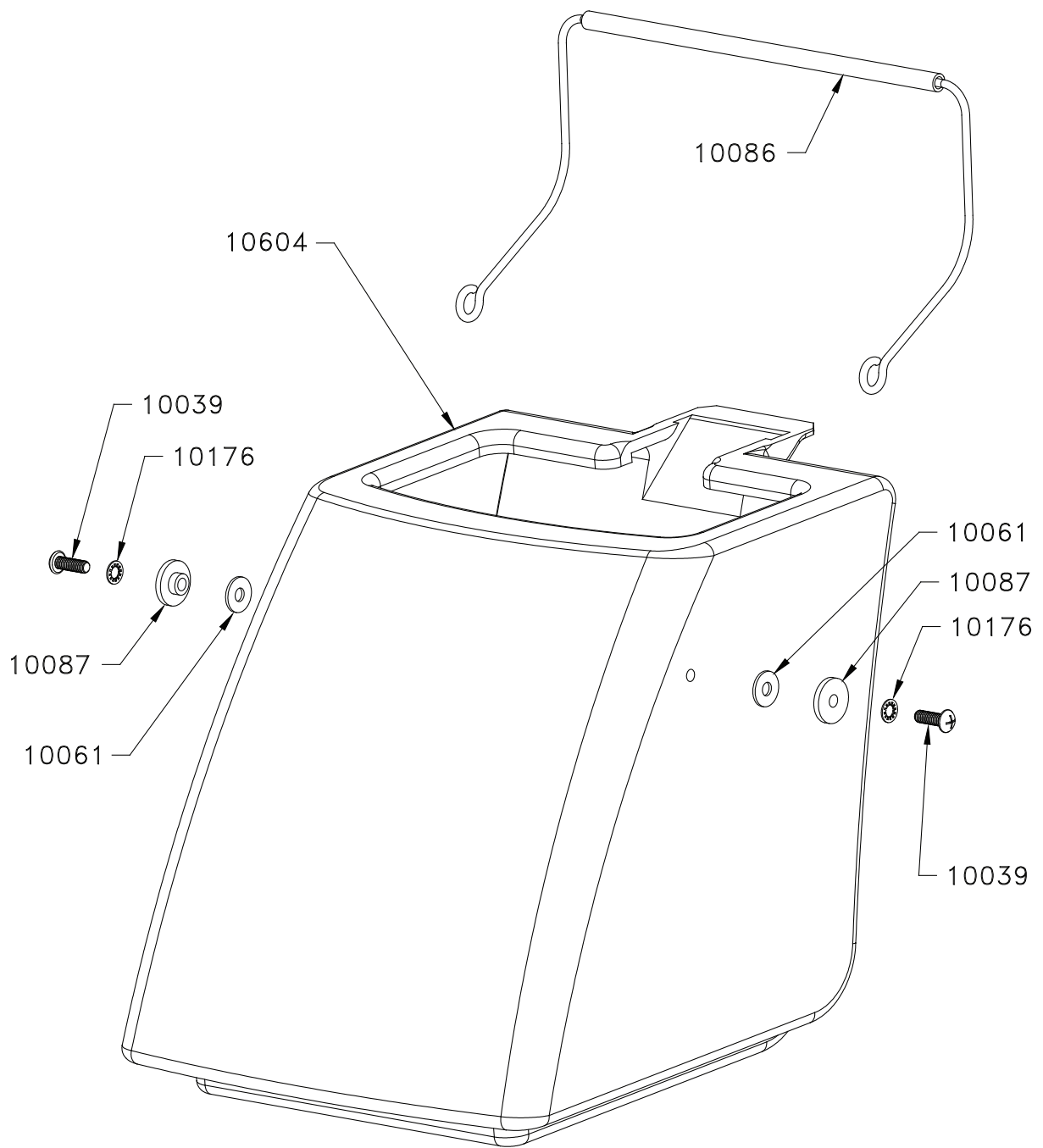

Bucket Assembly C4-A

Part #	Description	Qty	Notes
10039	Bolt, 1/4-20 x 3/4 Phil SS	2 ea	
10061	Washer, Flat 1/4 SS	2 ea	
10086	Handle, Bucket Bail	1 ea	
10087	Bushing, Flanged-Bucket	2 ea	
10176	Washer, Lock 1/4	2 ea	
10448	Decal, CRI	1 ea	
10604	Bucket C4-A, Blue	1 ea	

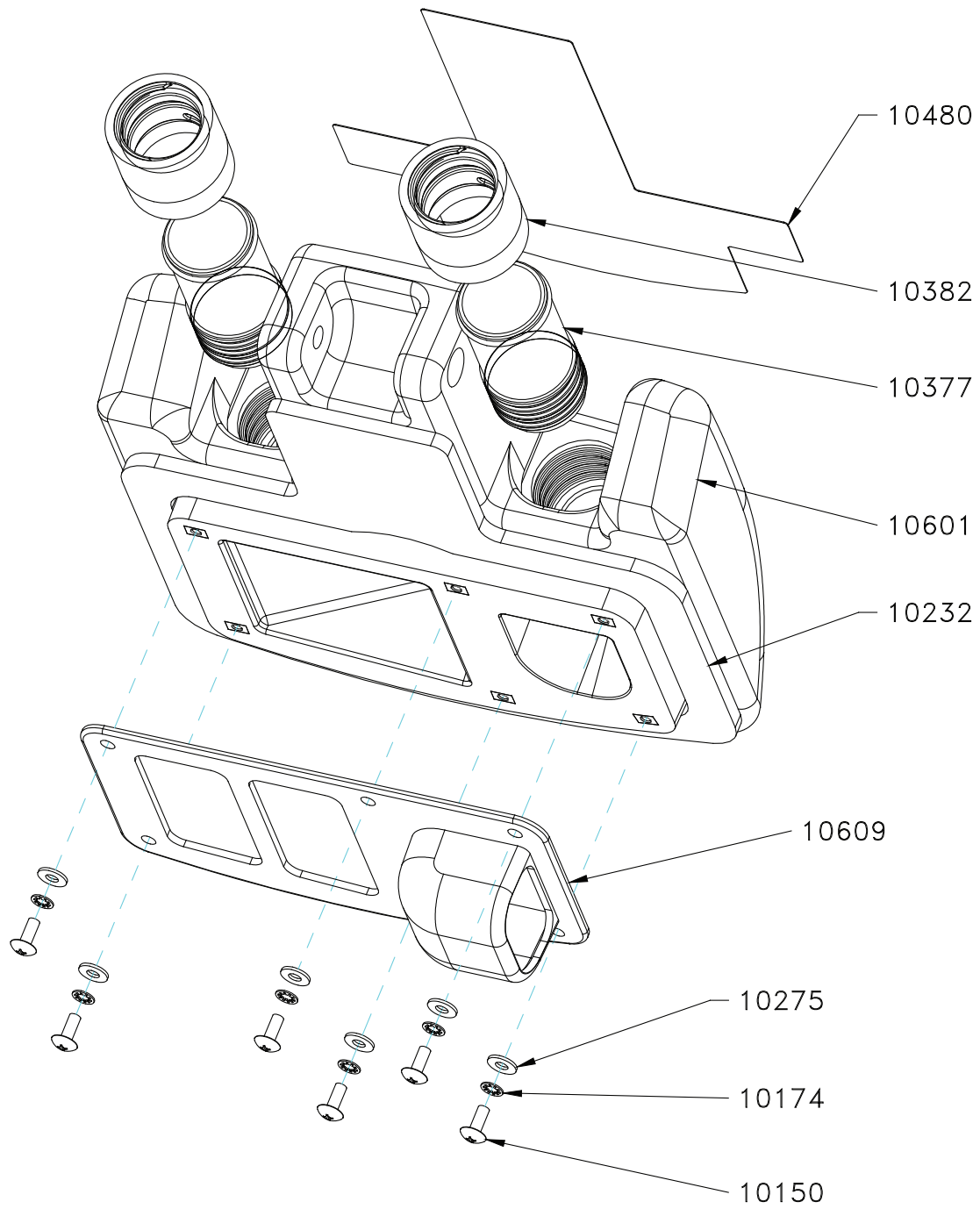

Lid Assembly C4-A

Part #	Description	Qty	Notes
7LIDL	Lid Assembly	1 ea	
	10150 Bolt, 10-24 x 1/2 Phil SS	6 ea	
	10174 Washer, Lock #10 SS	6 ea	
	10275 Washer, Flat #10 SS	6 ea	
	10377 Tube, Sight	2 ea	
	10480 Decal, Instruction- Lid QD	1 ea	
	10601 Lid, Gray (NFS)	1 ea	
	10609 Lid, Plate w/Filter Screen	1 ea	
10232	Gasket Lid/Duct 1/4 C4-A	1 ea	
10382	Cuff, Hose-Lid	2 ea	

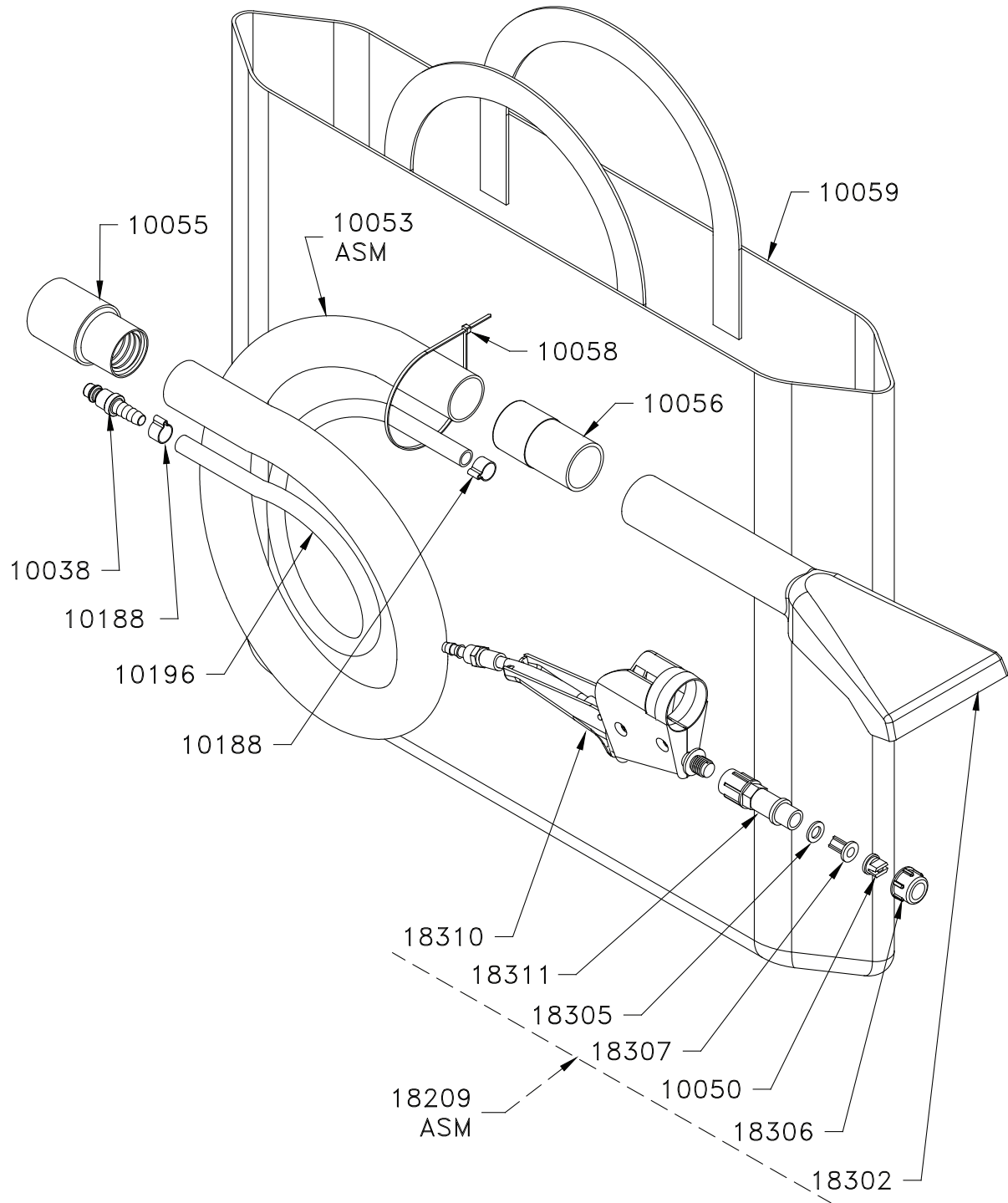

Hand Tool Kit C4-A

Part #	Description	Qty	Notes	
8HTK	Hand Tool Kit	1 ea		
	10038	Brass, Plug 1/4 Barb	1 ea	
	10053	Hose, Vac-H.T. 1" x 10' With Cuffs	1 ea	
	10055	Cuff, Hose-Enlarger 1 to 1 1/4	1 ea	
	10056	Cuff, Hose-Straight 1	1 ea	
	10058	Wire, Tie-11	4 ea	
	10059	Bag, H.T. - Gray With Print	1 ea	
	10188	Clamp, 1/4 Sol. Hose SS	2 ea	
	10196	Hose, Sol. Hand Tool 1/4 I.D. x 126	1 ea	
	18209	Hand Tool Assembled	1 ea	
	10050	Spray Tip, 11002-Hand Tool	1 ea	
	18302	H.T. Plastic Body	1 ea	
	18305	H.T. Washer, Spray Tip	1 ea	
	18306	H.T. Ring, Spray Tip	1 ea	
	18307	H.T.Filter, Spray Tip	1 ea	
18311	H.T. Tube Ext.	1 ea		
18310	H.T. Valve Assembly	1 ea		

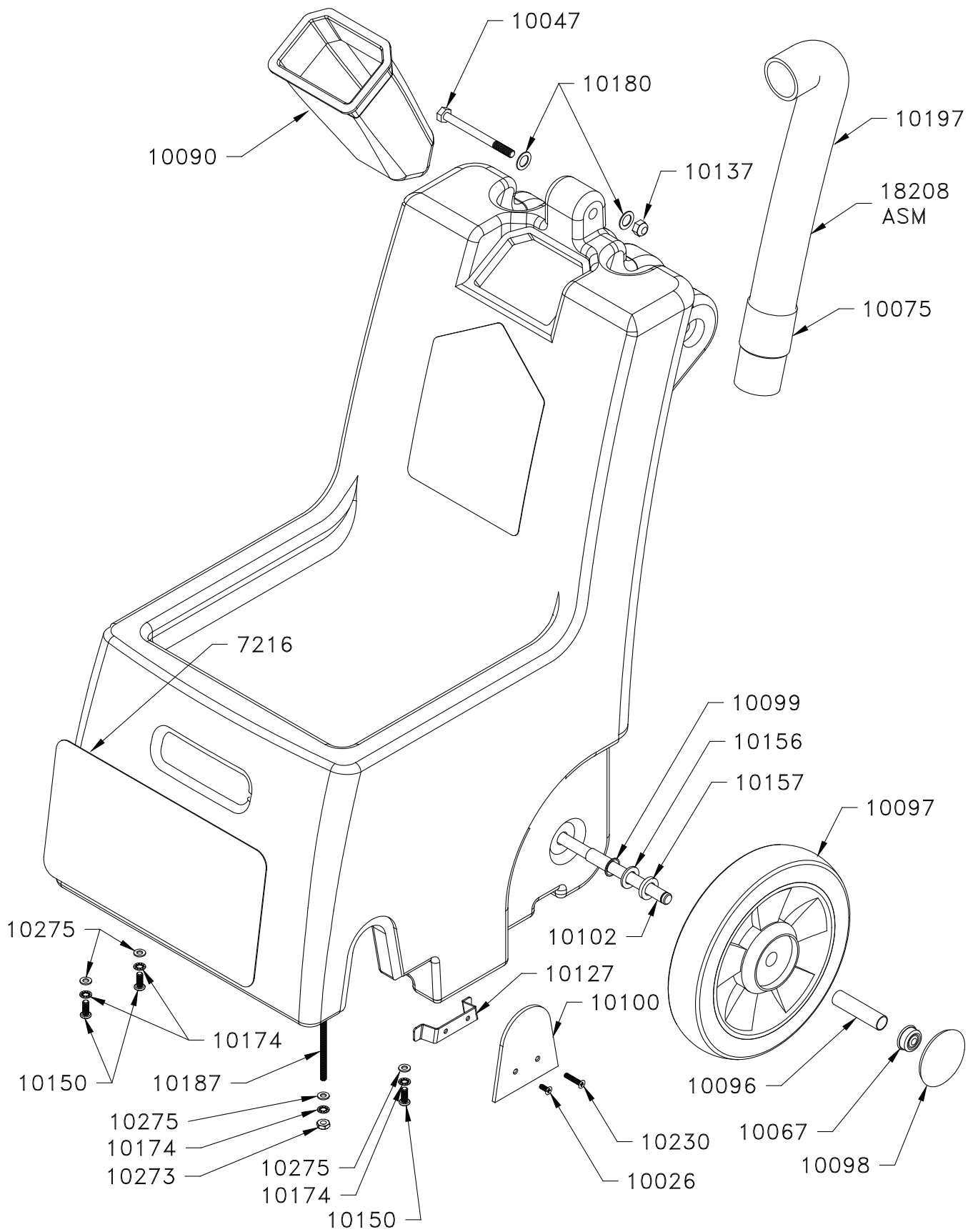

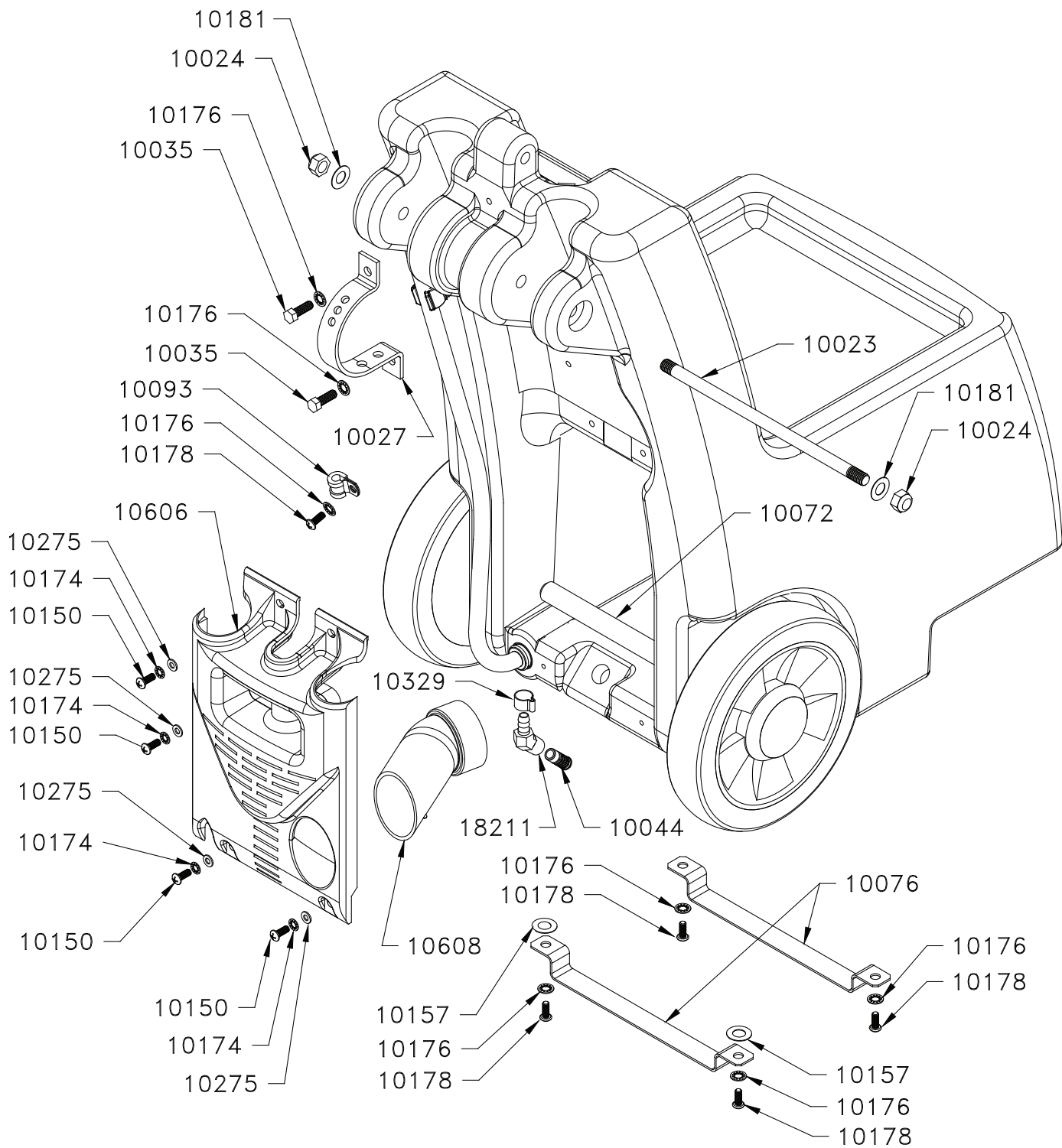

Final Assembly C4-A

Part #	Description	Qty	Notes
7216	Decal, Purent	1 ea	
10023	Stud, Handle Mount-3/8 Alum	1 ea	
10024	Nut, 3/8 16-Nylock	2 ea	
10026	Bolt, 6-32 x 3/8 Phil Flat SS	1 ea	
10027	Bracket, Detent-Handle Adjust	1 ea	
10035	Bolt, 1/4-20 x 3/4 Hex SS	2 ea	
10044	Filter, S Tank to Pump	1 ea	
10047	Bolt, 1/4-20 x 3 Hex SS	1 ea	
10067	Cap, Shaft-Axle	2 ea	
10072	Tube, Shaft, Wheel-1/2 I.D. x 6	1 ea	
10076	Strap, Duct	2 ea	
10090	Filter Bag, Sol. Tank	1 ea	
10093	Clamp, Loop Cushioned-3/8	1 ea	
10096	Spacer, Wheel	2 ea	
10097	Wheel, 7"	2 ea	
10098	Hub Cap, Wheel-Black	2 ea	
10099	Brass Eyelet	2 ea	
10100	Cover, Belt-Gray	1 ea	
10102	Shaft, Wheel SS	1 ea	
10127	Bracket, Cover Belt	1 ea	
10137	Nut 1/4-20 Nylock SS	1 ea	
10150	Bolt, 10-24 x 1/2 Phil SS	7 ea	
10156	Spacer, Nylon-Wheel (Thin)	1 ea	
10157	Spacer, Nylon-Wheel (Thick)	3 ea	
10174	Washer, Lock #10 SS	8 ea	
10176	Washer, Lock 1/4 SS	7 ea	
10178	Bolt, 1/4-20 x 5/8 Phil SS	5 ea	
10180	Washer, .39 x .625 x .031 SS	2 ea	
10181	Washer, .39 x .75 x .02 SS	2 ea	
10187	Stud, Threaded 10-24 x 2 7/8 SS	1 ea	
10230	Bolt, 6-32 x 3/4 Phil Flat SS	1 ea	
10273	Nut, 10-24 Hex SS	1 ea	
10275	Washer, Flat #10 SS	8 ea	
10329	Clamp, Gear Pump 5/8"	1 ea	
10606	Door, Gray C4-A	1 ea	
10608	Tube, Exhaust, Black C4-A	1 ea	
18208	Hose Vac-Lid to Disconnect with Cuff	1 ea	
	#10075 Cuff, Hose-Male Gray	1 ea	
	#10197 Hose, Vac-Lid to Disconnect Length 13 1/2	1 ea	
18211	Brass, Elbow-45D	1 ea	