

SINCE 1839

**BRINLY**

SINCE 1839

**BRINLY**

# OWNER'S MANUAL

## **LAWN SWEEPER**

MODEL:

**STS-427LXH**

- Assembly
- Installation
- Operation
- Repair Parts

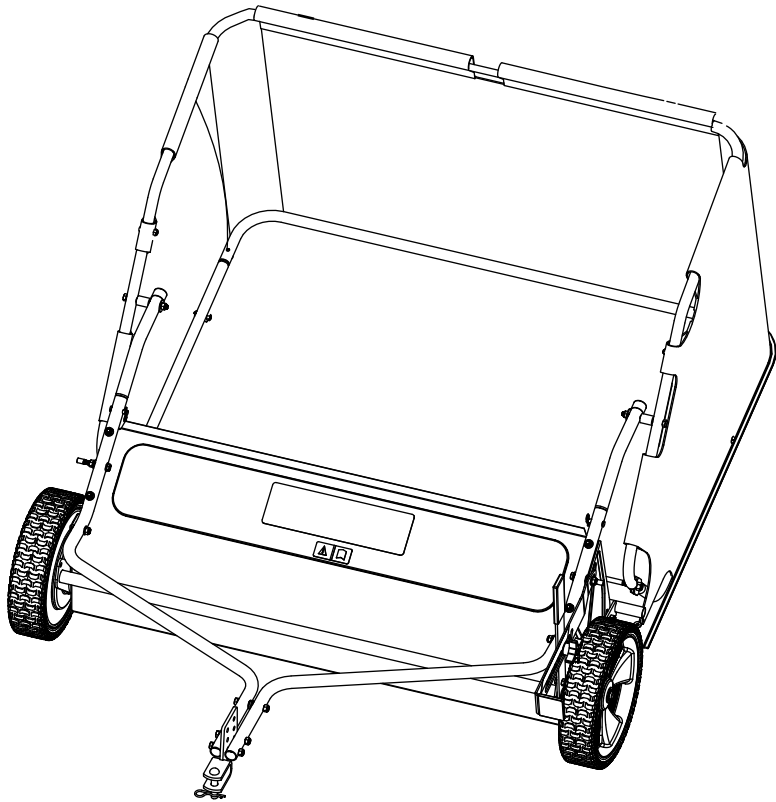

Visit us on the web!  
[www.brinly.com](http://www.brinly.com)

Important: This manual contains information for the safety of persons and property. Read it carefully before assembly and operation of the equipment!

1009725-B

# INTRODUCTION AND SAFETY

CONGRATULATIONS on the purchase of your new Brinly-Hardy Sweeper! Your Sweeper has been designed, engineered and manufactured to give you the best possible dependability and performance.

Should you experience any problem you cannot easily remedy, please do not hesitate to contact our knowledgeable customer service department toll-free at 1-877-728-8224. We have competent, well trained technicians to help you with the assembly and use of your Sweeper.

## CUSTOMER RESPONSIBILITIES

Please read and retain this manual. The instructions will enable to assemble and maintain your Sweeper properly.

Please carefully read and observe the SAFETY section of this manual.

Follow a regular schedule in maintaining and caring for your Brinly-Hardy Sweeper.

## TABLE OF CONTENTS

SAFETY.....	2
COMPONENT VIEW AND REFERENCE LIST.....	4-6
ASSEMBLY.....	7-15
SPECIFICATIONS.....	15
OPERATION.....	16-19
MAINTENANCE.....	20-22
LIMITED WARRANTY.....	23

## SAFETY

### SAFETY LABELS AND NOTATION

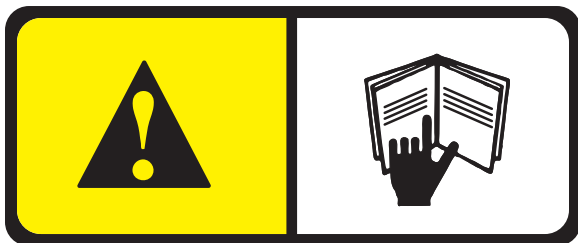
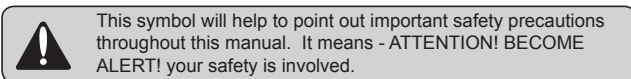

B-7063 (To Scale)

The safety labels shown in this section are placed in important areas on your product to draw attention to potential safety hazards.

On your product safety labels, the words DANGER, WARNING and CAUTION are used with the safety-alert symbol. DANGER identifies the most serious hazards.

The operator's manual also explains any potential safety hazards whenever necessary in special safety messages that are identified with the word, CAUTION, and the safety-alert symbol.

### GENERAL NOTES (OPERATION)

Caution should be taken when towing and/or using any attachment. This attachment combined with the weight distribution, turning radius, and speed of towing vehicle can result in severe injury or death to operator, damage to towing vehicle, and/or attachment if not used properly. Follow all towing safety precautions noted in the towing vehicle owner's manual, including the following precautions:

- Ensure the combined weight of the towing vehicle (tow vehicle weight + operator weight) is greater than the maximum towed weight of attachment (empty attachment weight + weight of load).
- Do not exceed maximum towing capacity of towing vehicle.
- Do not exceed the maximum drawbar pull rating of the towing vehicle. Drawbar pull is the horizontal force required to pull the attachment (including weight of load).
- Only tow this product in the vehicle's tow mode/speed setting or less than 5 mph. Do not exceed 5 mph.
- Towing speed should always be slow enough to maintain control. Travel slowly and use caution when traveling over rough terrain. Avoid holes, rocks and roots.
- Slow down before you turn and do not turn sharply.
- Use wide turning angles to ensure the attachment follows the path of the towing vehicle.
- Do not use attachment on steep slopes. A heavy load could cause loss of control or overturn attachment and towing vehicle. Additional weights may need to be added to your vehicle; check with towing vehicle manufacturer for recommendations.
- Reduce towed weight when operating on slopes.
- Keep all movement on slopes slow and gradual. Do not make sudden changes in speed, directions, or turning.
- If you start and stop suddenly on hills, you may lose steering control or the towing vehicle may tip. Do not start or stop suddenly when going uphill or downhill. Avoid uphill starts.
- Slow down and use extra care on hillsides. Turf conditions can affect vehicle stability. Use extreme caution while operating near drop-offs.
- Do not drive close to creeks, ditches and public highways.
- Watch out for traffic when crossing near roadways.
- Use care when loading or unloading the vehicle into a trailer or truck.
- The attachment can obstruct the view to the rear. Use extra care when operating in reverse.
- When reversing, carefully back-up straight to avoid jackknifing. Do not allow towing vehicle wheels to contact attachment draw bar. Damage could result.
- Stop on level ground, disengage drives, set the parking brake, and shut off engine before leaving the operator's position for any reason including emptying the attachment.
- Use this attachment for intended purpose only.
- This attachment is intended for use in lawn care and home applications. Do not tow behind a vehicle or on a highway or in any high speed applications. Do not tow at speeds higher than maximum recommended towing speed.

- Do not tow this product behind a motor vehicle such as a car or truck.
- Always wear substantial footwear. Do not wear loose fitting clothing that can get caught in moving parts.
- Keep your eyes and mind on your towing vehicle, attachment and area being covered. Do not let other interests distract you.
- Stay alert for holes and other hidden hazards in the terrain
- Keep the towing vehicle and attachment in good operating condition and keep safety devices in place.
- The towing vehicle and attachment should be stopped and inspected for damage after striking a foreign object. Any damage should be repaired before restarting and operating the equipment.
- Keep all parts in good condition and properly installed. Fix damaged parts immediately. Replace worn or broken parts. Replace all worn or damaged safety and instruction decals. Keep all nuts, bolts and screws tight.
- Do not modify the attachment or safety devices. Unauthorized modifications to the towing vehicle or attachment may impair its function, safety and void the warranty.

#### TOWING VEHICLE AND TOWING SAFELY

- Know your towing vehicle controls and how to stop safely. READ YOUR TOWING VEHICLE OWNER'S MANUAL before operating.
- Check the towing vehicle brake action before you operate. Adjust or service brakes as necessary.
- Stopping distance increases with speed and weight of towed load. Travel slowly and allow extra time and distance to stop.
- Use only approved hitches. Tow this attachment only with a towing vehicle that has a hitch designed for towing. Do not connect this attachment except at the approved hitch point.
- Follow the tow vehicle manufacturer's recommendations for weight limits for towed equipment and towing on slopes. Use counterweights or wheel weights as described in the towing vehicle operator's manual.
- Do not shift to neutral and coast downhill.
- Do not allow children to operate the towing vehicle. Do not allow adults to operate the towing vehicle without proper instruction or without having read the owner's manual.

#### PROTECT THOSE AROUND YOU

- Before you operate any feature of this attachment or towing vehicle, observe your surroundings and look for bystanders.
- Keep children, bystanders and pets at a safe distance away while operating this or any attachment.
- Use care when reversing. Before you back up, look carefully behind for bystanders.

#### KEEP RIDERS OFF TOWED ATTACHMENT AND TOWING VEHICLE

- Do not carry passengers.
- Do not let anyone, especially children, ride in/on this attachment, the towing vehicle or hitch bracket. Riders are subject to injury such as being struck by foreign object and/or being thrown off during sudden starts, stops and turns. Riders may also obstruct the operator's view resulting in this attachment being operated in an unsafe manner.

# COMPONENT VIEW AND REFERENCE LIST

REF	PART NO.	DESCRIPTION	QTY	REF	PART NO.	DESCRIPTION	QTY
1	1008953-10	Lock Arm	1	46	1008987	Wheel	2
2	1008958-10	Height Adjustment Handle	1	47	1008992-10	Hamper Stop	1
3	1008960-10	Tow Tube, Right	1	48	11M0808P	1/4" x 1/2" Carriage Bolt	6
4	1008961-10	Tow Tube, Left	1	49	50M0624P	3/16" x 1-1/2" Cotter Pin	4
5	1008962-10	Hamper Mount	2	50	B-4768	5/8" Machine Bushing	4
6	1008965	5/16" x 1" Spacer	2	51	B-5924	Brinly Decal	1
7	1009047	Vinyl Bolt Cap	2	52	B-7063	Caution Label	1
8	1009058	Vinyl Grip	1	53	F-577	5/8" E Ring	6
9	11M1020P	5/16" x 1-1/4" Carriage Bolt	1	54	L-1744	Label, Serial No	1
10	11M1024P	5/16" x 1-1/2" Carriage Bolt	6	55	R-2205	Brush Section	6
				56	R-2259-01	Brush Axle	1
				57	R-2261	1/4" x 3/4" Dowel Pin	2
13	2M1012P	5/16" x 3/4" Hex Bolt	5	58	R-2262	5/8" Large Flat Washer	2
14	2M1044P	5/16" x 2-3/4" Hex Bolt	3	59	R-2263	5/8" Flat Washer	2
15	2M1056P	5/16" x 3-1/2" Hex Bolt	2	60	R-2281	Brush Holder	4
16	30M1000P	5/16" Hex Nut	2	61	R-2289SER	Bearing Retainer	2
17	30M1200P	3/8" Hex Nut	2	62	R-2320	5/8" External Retaining Ring	2
18	40M1000P	5/16" Lock Washer	2	63	R-2321	Screw, Tapping, #12 X 3/8	4
19	45M1111P	5/16" Washer	14	64	R-2485LH	LH Drive Pinion	1
20	B-1673P	1/4" Lock Nut	6	65	R-2485RH	RH Drive Pinion (Not Shown)	1
21	B-1674P	5/16" Lock Nut	1	66	R-2194-10	Rear Hamper Tube	2
22	B-1675P	3/8" Lock Nut	2	67	R-2195	Hamper Stop Rod	1
23	B-3861	1/2" X 2-1/2" Hitch Pin	1	68	R-2251-10	Hitch Clevis	1
24	B-4107	1" Vinyl Cap	2	69	R-2443-10	Lower Side Tube	2
25	B-4786	5/16" Nylon Lock Nut	16	70	R-2307	Spring Rod	2
26	1009205	Grip	1				
27	B-4868	5/16" x 2-1/2" Hex Bolt	2				
28	B-5650	5/16" Star Lock Washer	1				
29	B-983	0.08" Hairpin Cotter	2				
30	D-146P	1/8" Hairpin Cotter	1				
31	F-782	5/16" Knob	1				
32	R-1141-01	Frame Spacer	1				
33	R-2303	5/16" X 1-3/8" Clevis Pin	2				
34	R-618	Large Washer	3				
35	1008997SER	Pull Handle	1				
36	1009049	Adhesive Hook and Loop	1				
37	1009639	Rope, Pull, Hamper	1				
38	R-2300-10	Upper Side Tube	2				
40	R-2426	Hamper	1				
41	1009046	Adjustment Label	1				
42	1008955	Dust Cover	2				
43	1008957-10	Lower Pivot	1				
44	1008959-01	Wheel Axle	2				
45	1008986-10SER	Brush Housing	1				

**Tools Required for Assembly:**

- 1/2" Wrench (2)
- 9/16" Wrench (2)
- 7/16" Wrench (1)
- Flat Tip Screw Driver (1)
- Pliers
- Gloves

# COMPONENT VIEW AND REFERENCE LIST

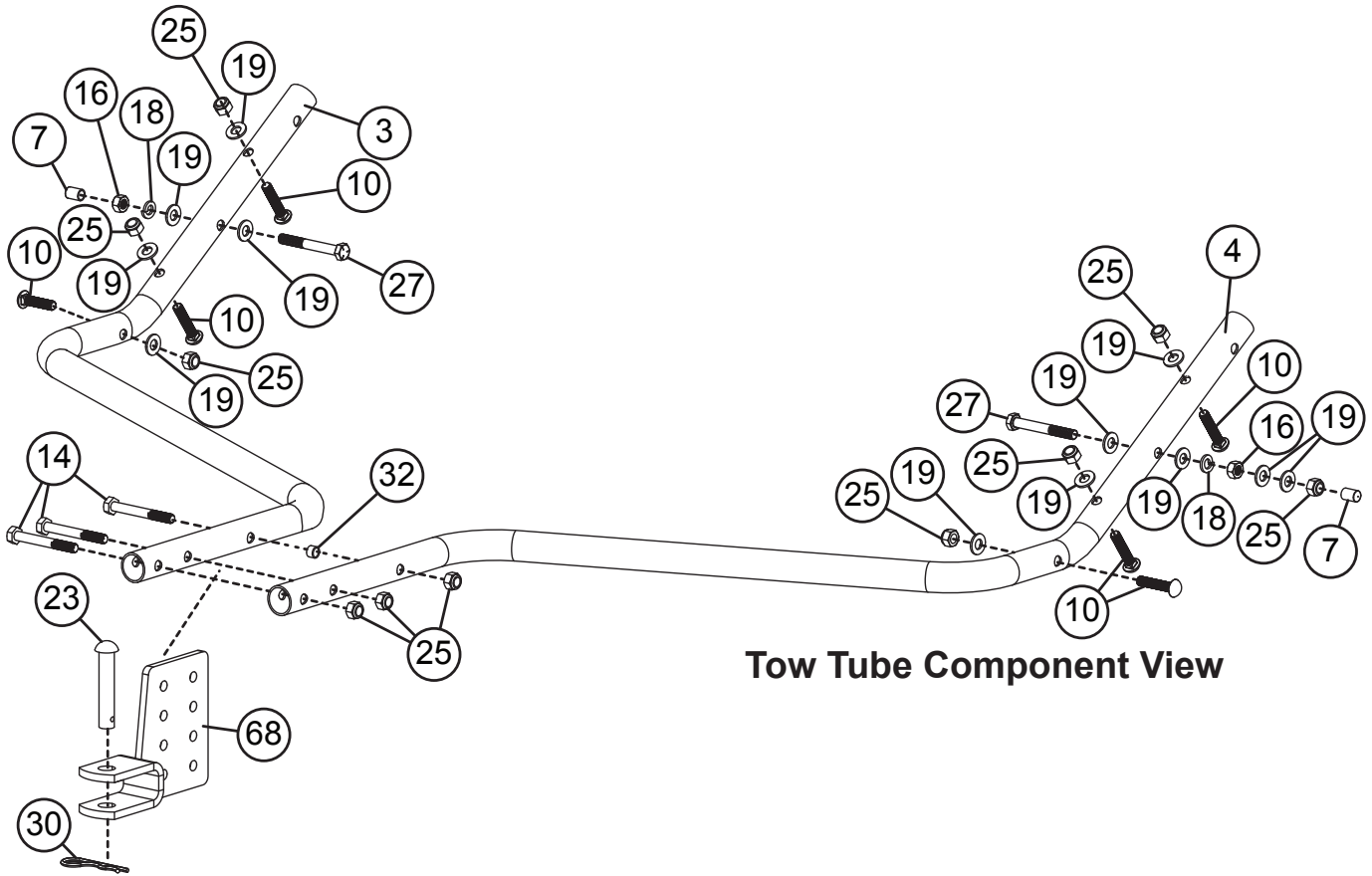

**Tow Tube Component View**

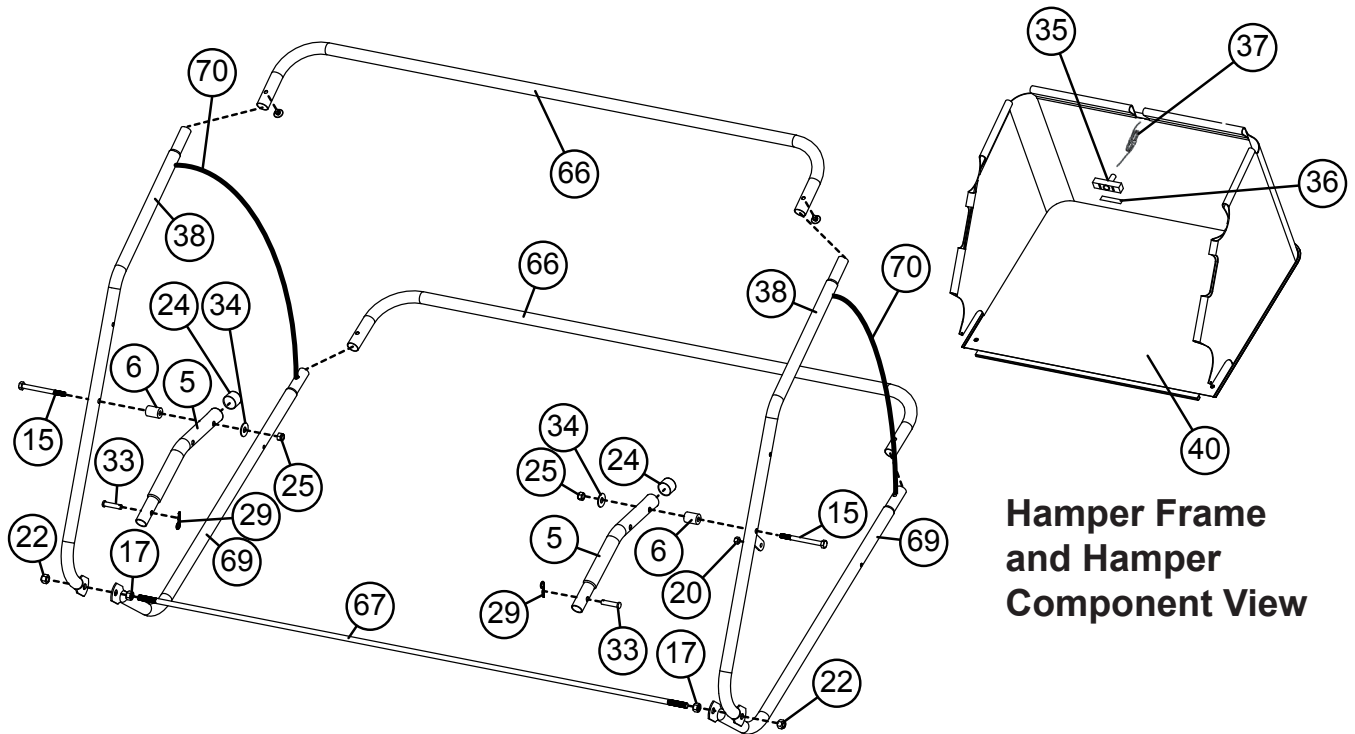

**Hamper Frame  
and Hamper  
Component View**

# COMPONENT VIEW AND REFERENCE LIST

## Brush Housing Component View

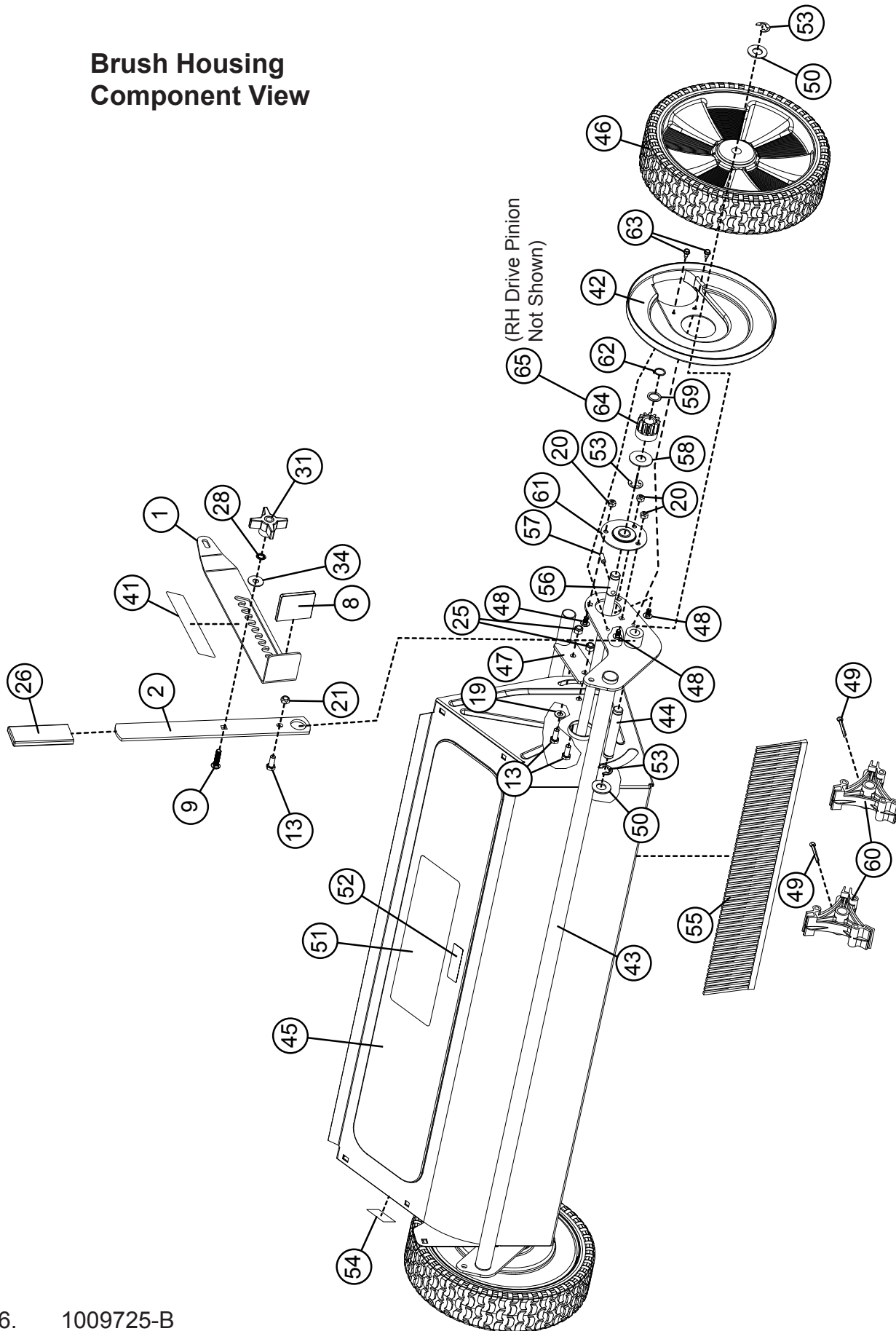

# ASSEMBLY

10" This manual will be referencing panels of the hardware skin pack included with your sweeper. The hardware in Panel 01 is to be used with Figure 01; Panel 02 with Figure 02; etc.

Figure 01

Assemble the Right Tow Bar (3) and Left Tow Tube (4) to the Brush Housing (45) using the hardware in Panel 01 as shown in Figure 01.

Do not tighten fasteners at this time.

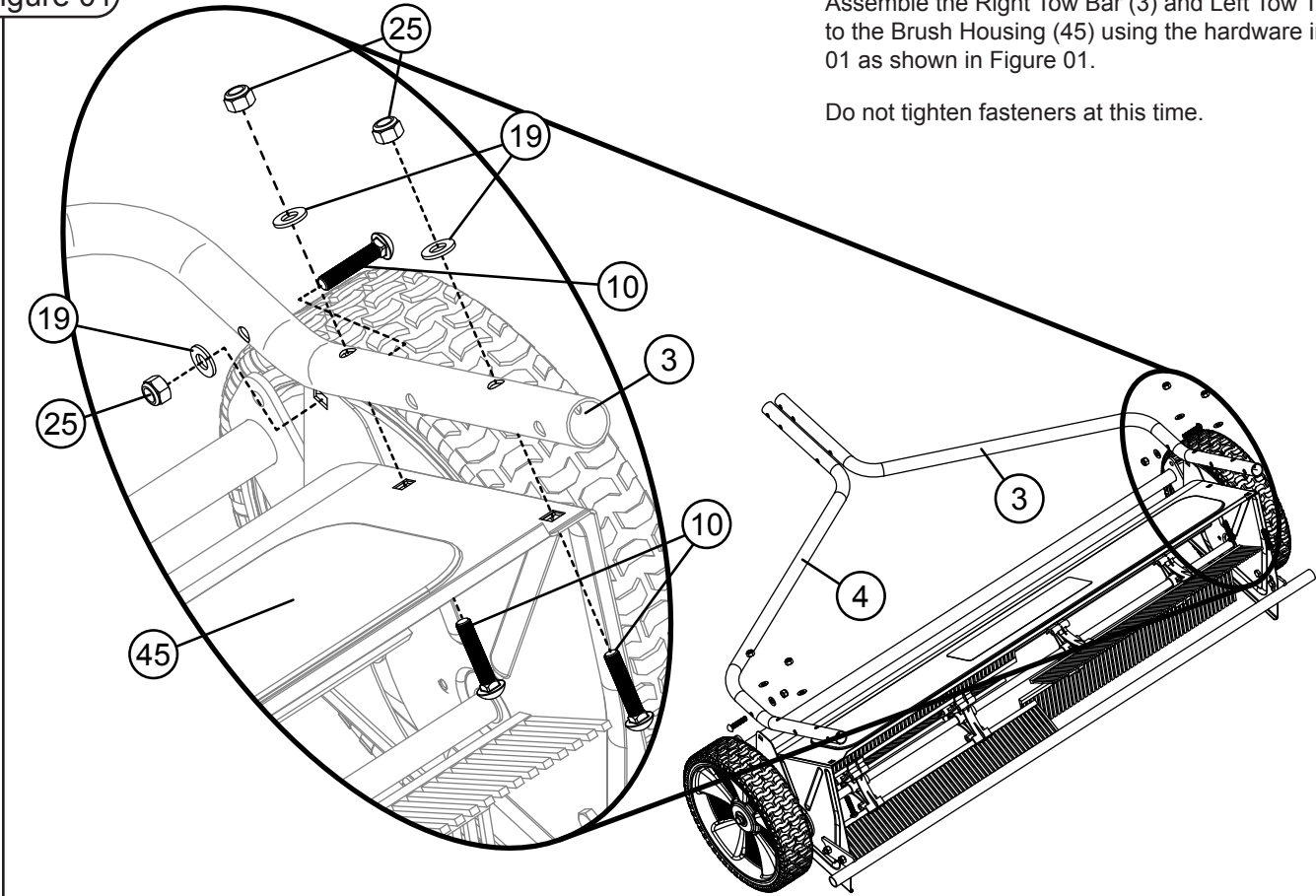

## Hitch Plate Height Measurement

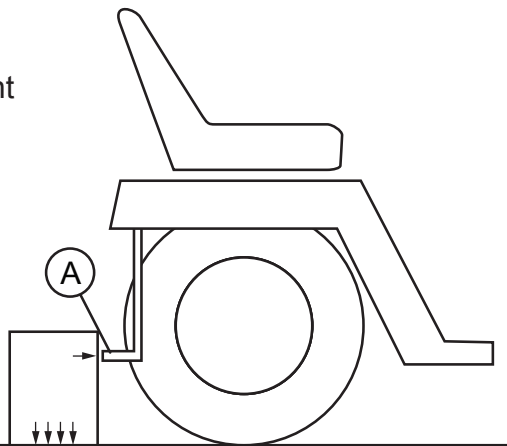

Park towing vehicle on a level, hard surface and set parking brake.  
 Measure from the ground to the bottom of the rear hitch plate (A).  
 Note: The scale at the side of this sheet can be used as a guide for hitch plate heights up to 11 inches.

Record this measurement here: \_\_\_\_\_  
 Round this measurement to the closest whole number: \_\_\_\_\_

For example:  
 If the hitch plate measurement is 7-1/4" round to 7".  
 If the hitch plate measurement is 8-3/4" round to 9".  
 If the hitch plate measurement is a half measurement, round up (example: 7-1/2" rounds to 8").

Place this edge on ground.



# ASSEMBLY

Figure 02

Height  
7"-10"

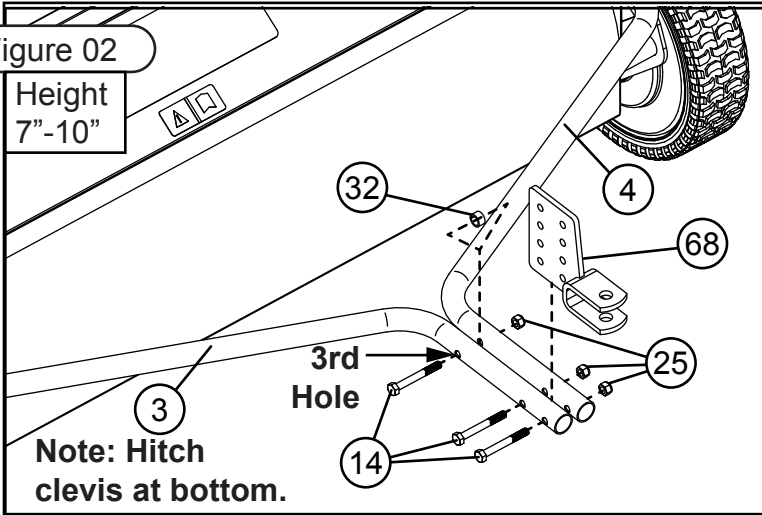

Hitch Height      Clevis Mount Holes

7"

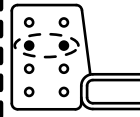

Using the rounded measurement from the previous section, determine the correct Clevis Assembly (68) mounting holes from the diagrams directly to the left

8"  
9"

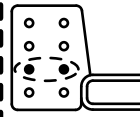

Note that hitch plate heights between 7" and 10" have the Clevis at the bottom of the bracket and hitch plate heights between 11" and 14" have the Clevis at the top of the bracket.

10"

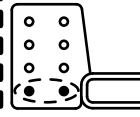
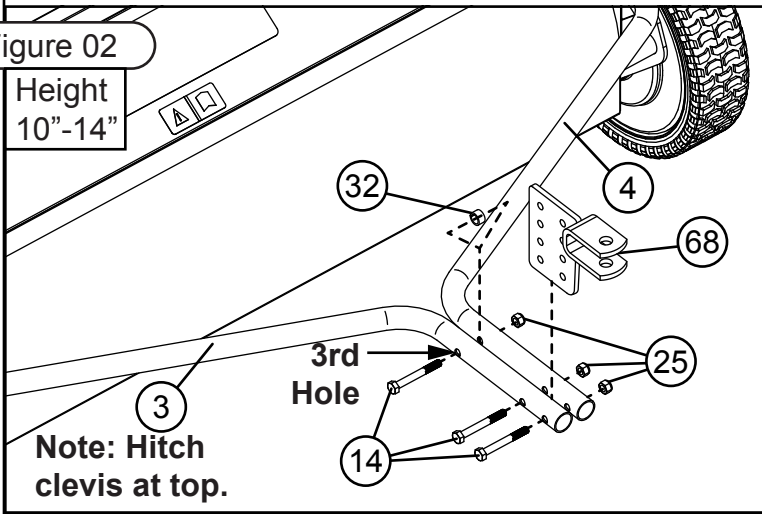
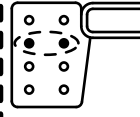

Figure 02

Height  
10"-14"



11"



Once the correct Clevis Assembly (68) mounting holes have been determined, attach the Clevis Assembly (68) between the Right and Left Tow Tubes (3 & 4) using the hardware in Panel 02 as shown in Figure 02.

12"  
13"

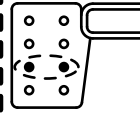

Do not tighten at this time.

14"

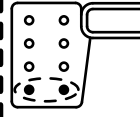

Use the remaining hardware from Panel 02 and attach the Right and Left Tow Tubes (3 & 4) at 3rd hole as shown in Figure 02.

Figure 03

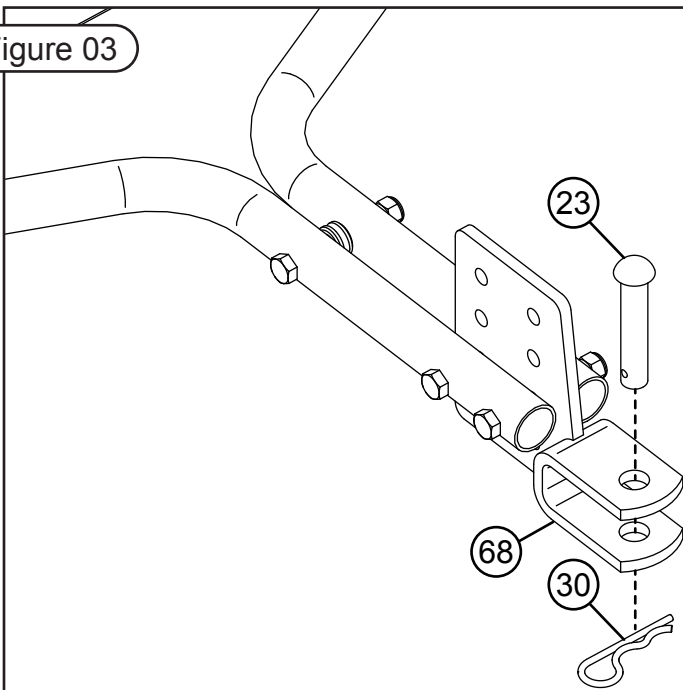

Tighten all hardware used in Figure 01 (6 Carriage Bolts and Nuts) and Figure 02 (3 Hex Bolts and Nuts).

Using the hardware in Panel 03, attach Hitch Pin (23) and Hairpin Cotter (30) to the Clevis Assembly.

# ASSEMBLY

Figure 04

Note: Wheel assembly not shown for clarity.

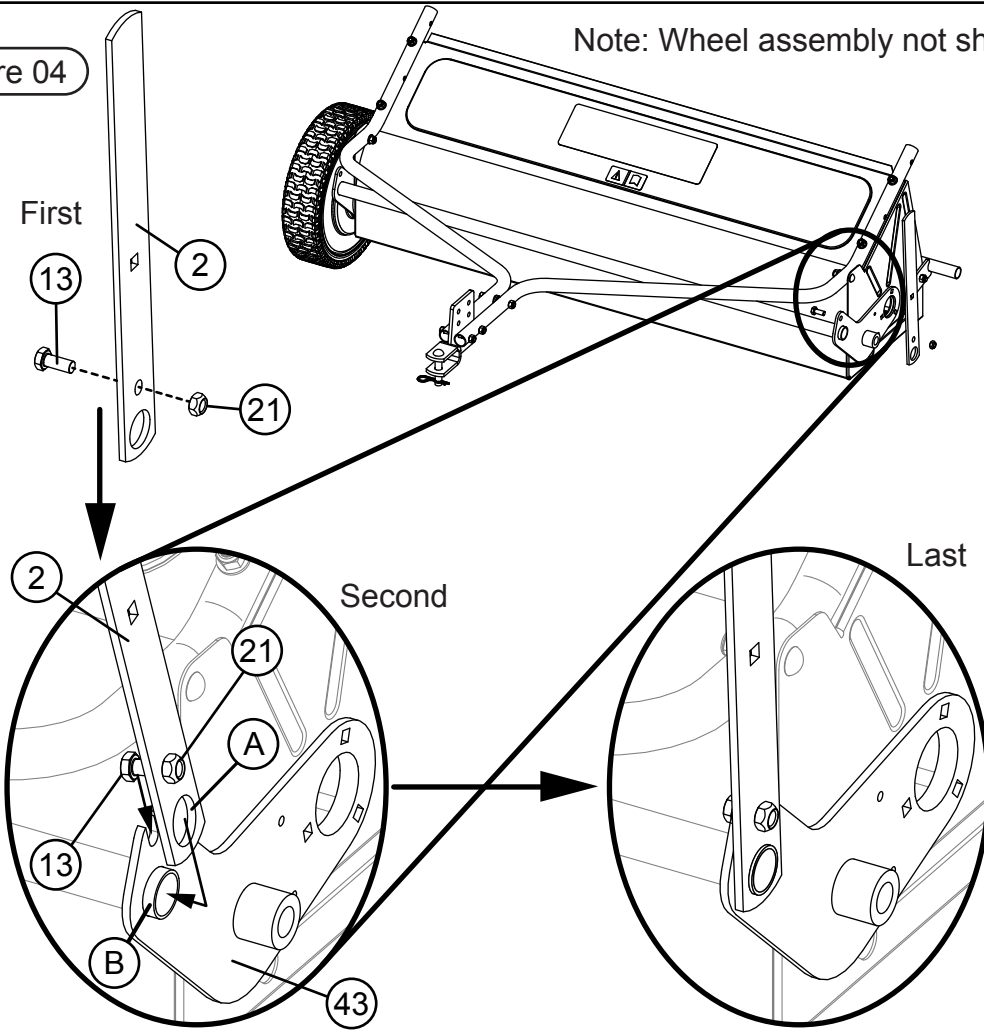

Attach Height Adjustment Handle (2) to Lower Pivot (43) side plate using Bolt (13) and Lock Nut (21) in Panel 04. Tighten hardware securely.

Note: Large hole (A) in bottom of the Height Adjustment Handle (2) must fit over the Tube (B) extending past the Lower Pivot (43) side plate.

Figure 05

Using the hardware in Panel 05:

First, assemble the Bolt (27) through the Left Tow Bar (4) as shown and tighten securely:

- Bolt (27)
- 2 Washers (19)
- Lock Washer (18)
- Nut (16)

Second, assemble the Lock Arm (1) to the bolt as shown:

- 2 Washers (19)
- Lock Arm (1)
- Nylon Lock Nut (1)

Note: Do not over tighten the Nylon Lock Nut (25). The Lock Arm (1) should be able to pivot freely after assembly.

Last, assemble over the end of the Bolt (27):

- Vinyl Bolt Cap (7)

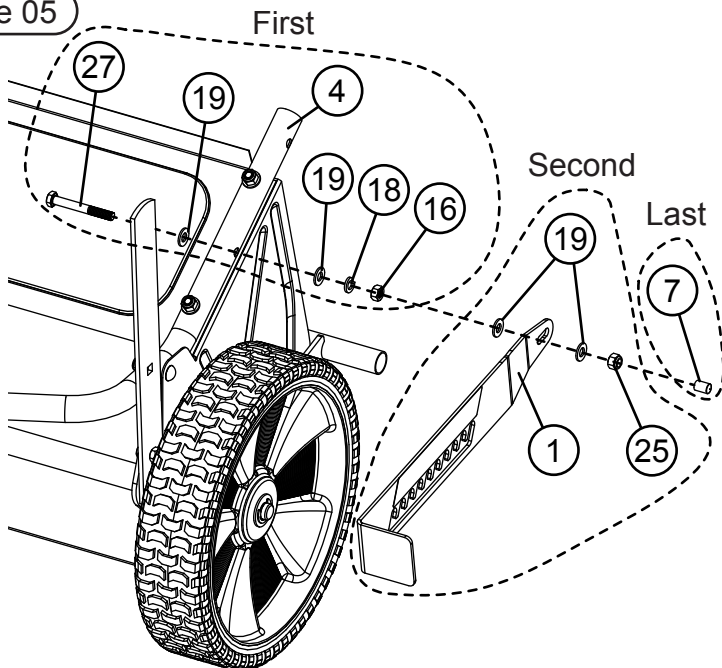

# ASSEMBLY

Figure 06

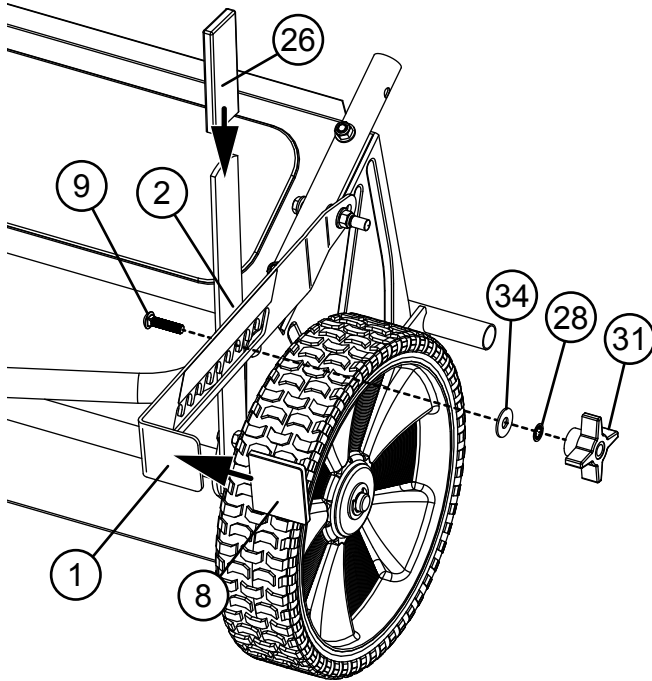

Attach Lock Arm (1) to Height Adjustment Handle (2) using the hardware in Panel 06 as shown in Figure 06.

Note: For proper function of the sweeper height adjustment mechanism, it is important to assemble the hardware as shown in Figure 06.

Attach Vinyl Grips (8) and (26) as shown in Figure 06.

Figure 07

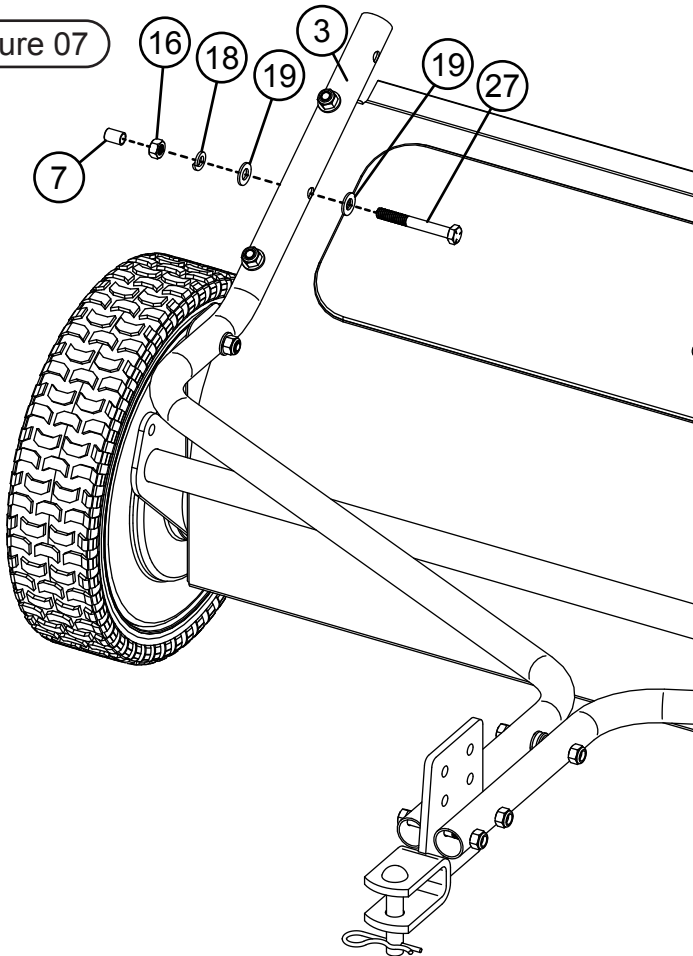

Assemble the hardware in Panel 07 to the Right Tow Bar (3) as shown in Figure 07. Tighten securely.

# ASSEMBLY

Figure 08

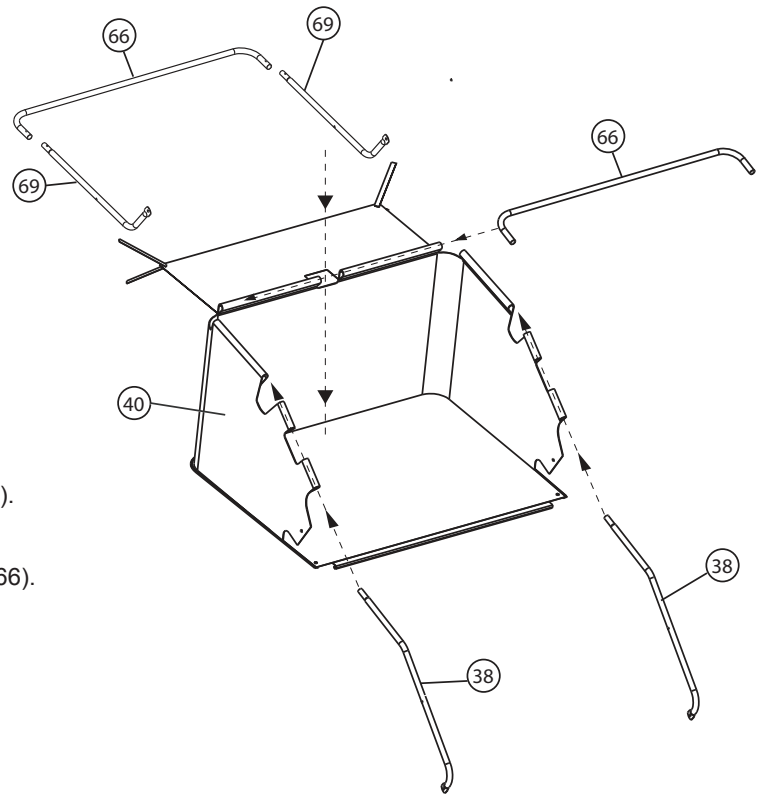

Assemble the rear tube (66) to the lower tubes (69) and install into the bottom of the hamper (40).

Assemble the rear tube (66) as shown.

Assemble the side tubes (38) into the rear tube (66).

# ASSEMBLY

Figure 09

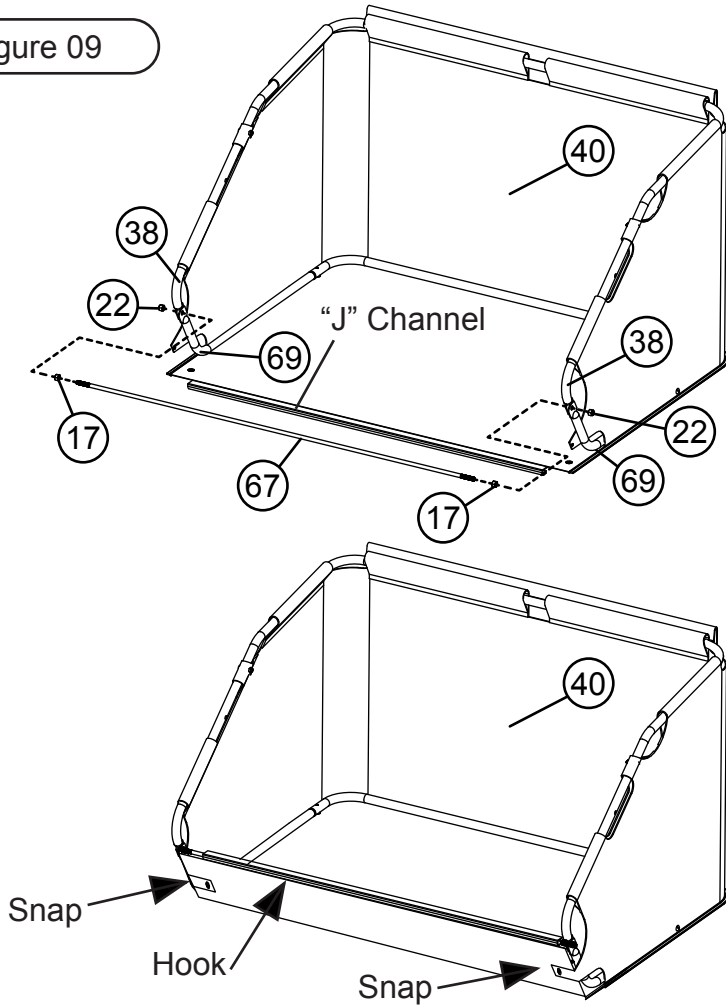

Using the hardware in Panel 10, assemble one 3/8" Nut (17) on each end of the Hamper Stop Rod (67) until it is approximately in the center of the threads.

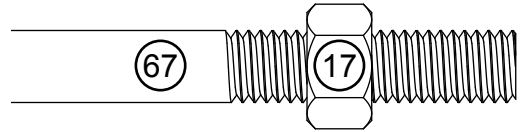

Assemble each end of the Hamper Stop Rod (67) through the holes on the front of the Upper Side Tubes (38) and Lower Side Tubes (69).

Using the remaining hardware in Panel 10, assemble one 3/8" Lock Nut (22) on each end of Hamper Stop Rod (67). Tighten the Lock Nut (22) until Hamper Stop Rod (67) is flush with the top of the Lock Nut (22).

Note: Hold the Hamper Stop Rod (67) with Pliers while tightening the Lock Nuts (22).

Upper and Lower Side Tubes should be trapped between the Nut (17) and Lock Nut (22) on the Hamper Stop Rod (67) but still loose enough to pivot freely. If the tubes do not pivot freely, loosen Nut (17).

Pull up on bottom of Hamper (40) from "J" Channel and hook "J" Channel onto Hamper Stop Rod (67).

Snap side flaps to Hamper (40) bottom as shown. Note: Flap should be on the outside of Lower Side Tubes (69) after assembly.

Figure 10

Locate and align the holes in the upper rear tube (66) with the side tubes (38). Locate and align the holes in the lower rear tube (66) with the bottom tube (69).

Stand in the bottom of the hamper. Insert the end of the spring rod (70) into the lower holes aligned in the previous step. Pull up on the upper rear tube (66) and insert the other end of the spring rod (70) into the upper holes.

Please note that this step must be done with eye protection (safety glasses) and gloves as the spring rod requires some force to install. After installation the spring rod will be slightly bent.

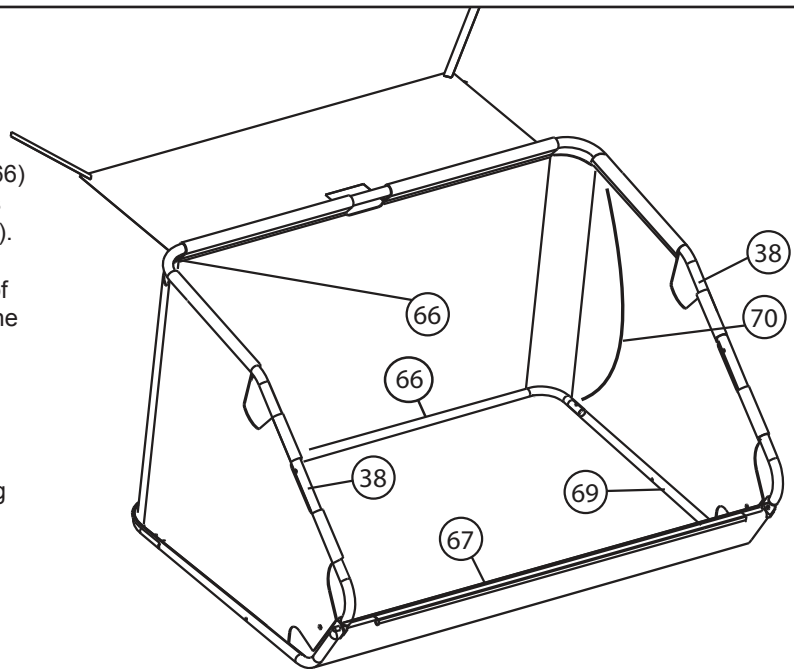

# BLANK PAGE

---

---

# ASSEMBLY

Figure 11

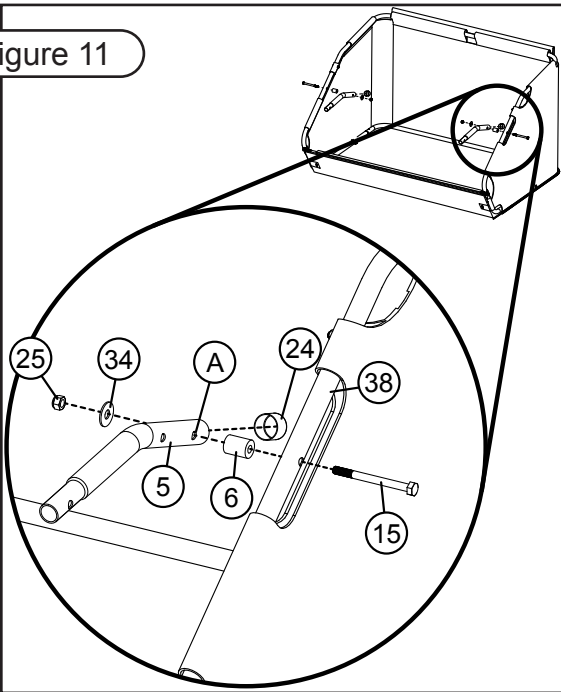

Using the hardware in Panel 11, assemble Hamper Mounts (5) to Upper Side Tubes (38) as shown in Figure 11. Ensure that the hole closer to the end of the upper side tube (A) is used as shown.

Note: Tighten Nylon Lock Nut (25) completely and then loosen enough so that the Hamper Mount (5) pivots freely.

Assemble Vinyl Caps (24) to Hamper Mounts (5) as shown.

# ASSEMBLY

Figure 12

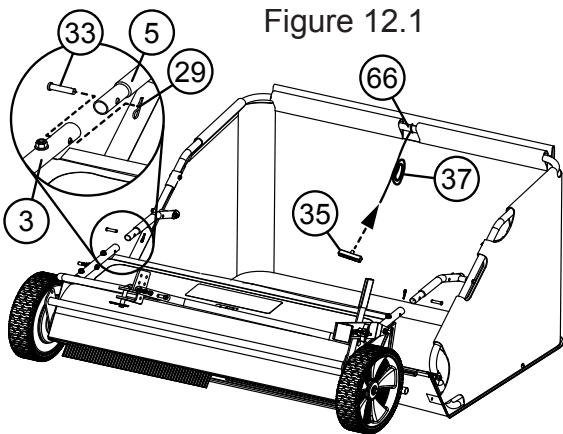

Figure 12.1

With the sweeper attached to the towing vehicle (see 'Attaching the Sweeper' section of this manual), connect the Hamper Assembly to the sweeper using the hardware in Panel 12 (see Figure 12.1).

Tie one end of Hamper Pull Rope (37) to the middle section of the upper Rear Hamper Tube (66) as shown (see Figure 12.1).

Thread Pull Handle (35) onto opposite end of the Pull Rope (37) as shown (Figure 12.2).

Figure 12.2

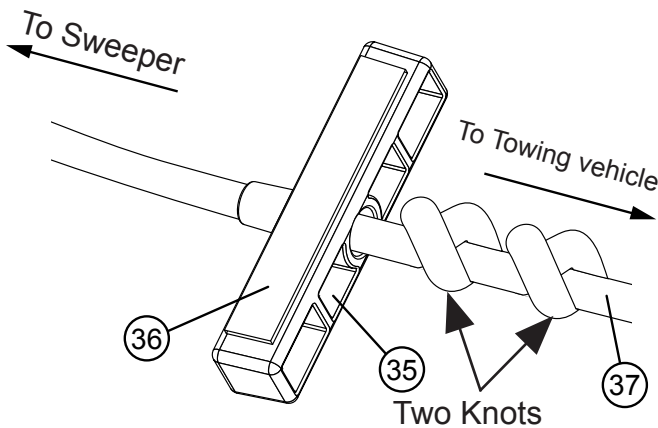

Extend Pull Rope (37) to the back of the towing vehicle to an area that will be easily accessible from the towing vehicle seat. This is the area that the Pull Handle (35) will be attached.

Allow the Pull Rope (37) to slacken several inches (droop between the towing vehicle and tied point on the Hamper – Figure 12.3).

In the area of the Pull Rope (37) determined above, tie 2 knots and pull the knots into the Pull Handle (35) (Figure 12.2).

Clean the area of the towing vehicle that the Pull Handle (35) will attach to.

Affix the adhesive Hook and Loop (36) tape to the back of the towing vehicle in the cleaned area.

Cut excess rope if needed.

Figure 12.3

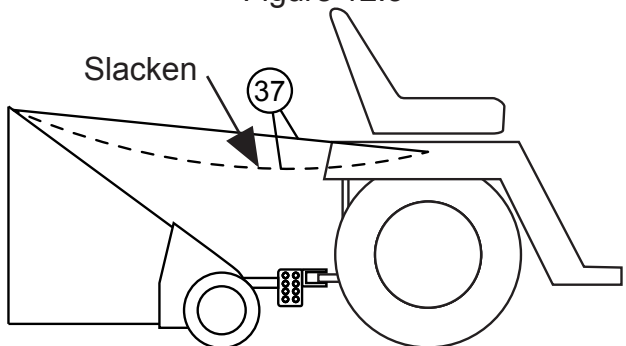

**Important: Pull Rope and Handle can get tangled in the sweeper brushes if they fall on the ground in front of the sweeper during operation. After dumping the hamper, always make sure to fully secure the Pull Handle to the back of the towing vehicle using the Hook and Loop tape.**

## SPECIFICATIONS

Maximum Towing Speed: 5 mph  
 Hamper Capacity: 20 cu. Ft.  
 Maximum Hamper Weight: 120 lbs  
 Empty Weight: 75 lbs  
 Maximum Towed Weight: 195 lbs

# OPERATION

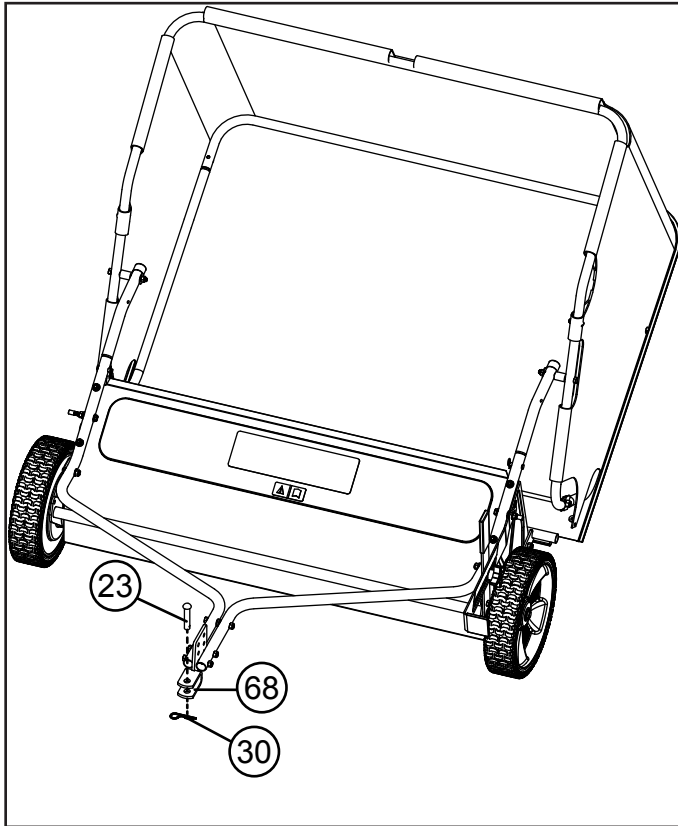

## Attaching the Sweeper



**CAUTION: Avoid Injury! Before attaching the Sweeper, make sure Hamper is empty of all material.**

1. Park towing vehicle on a hard, level surface and set parking brake.
2. Align Clevis (68) with towing vehicle hitch plate.
3. Install Hitch Pin (23) through Clevis Assembly (68) and towing vehicle hitch plate and secure with Hairpin Cotter (30).

## Removing the Sweeper



**CAUTION: Avoid Injury! Before removing the Sweeper, make sure Hamper is empty of all material.**

1. Confirm Hamper is empty
2. Park towing vehicle on a hard, level surface and set parking brake.



**CAUTION: Avoid Injury! Sweeper and sweeper Tow Bar will shift after removal of Hitch Pin. Use caution when removing Hitch Pin and moving sweeper.**

3. Remove Hairpin Cotter (30) and Hitch Pin (23).
4. Push sweeper away from towing vehicle.
5. Install Hitch Pin (23) through Clevis Assembly (68) and secure with Hairpin Cotter (30) for storage.

## Adjusting to Transport Position

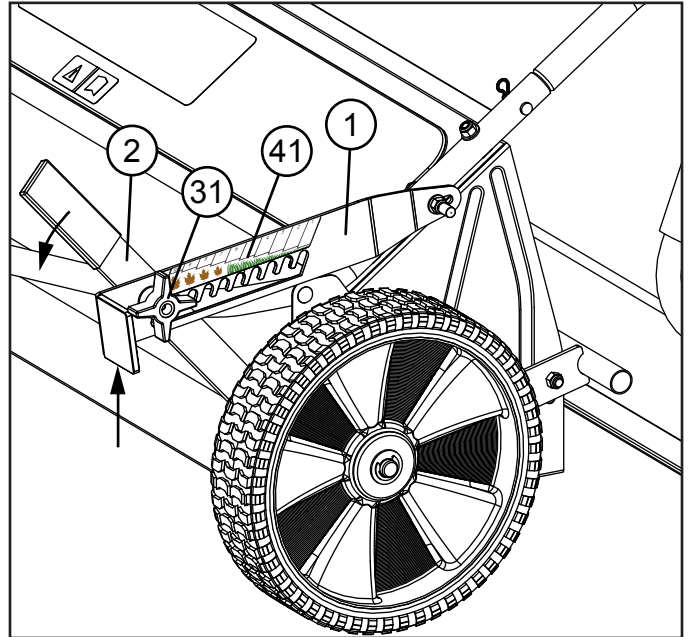

To adjust the Sweeper for Transport:

1. Park towing vehicle on a hard, level surface and set parking brake.
2. Loosen (but do not remove) Knob (31) and adjust Lock Arm (1) to the 10th position (as indicated on the Adjustment Label (41)). For adjustment instructions, see the "Adjusting the Brush Height" section.

## Determining Maximum Towed Weight



**CAUTION: Avoid injury! Excessive towed load can cause loss of traction and loss of control on slopes. Stopping distance increases with speed and weight of towed load. Total towed weight must not exceed combined weight of towing vehicle, ballast and operator.**

The following maximum loaded weight is the average weight of the sweeper plus the weight loaded in the hamper.

Model	Weight Capacity
STH-420BH	75 lbs empty
STS-427LXH	195 lbs with wet grass



**Caution: Avoid Injury! If additional weight is required when towing, add weight at or forward of the rear wheels. Adding weight behind the rear wheels can affect vehicle steering. Refer to your towing vehicle manual for information regarding addition of weight.**

Towing capacity will vary with the weight of the towing vehicle and operator. Add the weight of your machine to operator weight to find the maximum capacity for towing.

# OPERATION

Example:

If towing vehicle weighs: 400 lbs  
 Add operator weight: 200 lbs  
 Combined weight equals: 600 lbs

To maintain stability in this example, you cannot safely tow more than 600 lbs without first adding ballast (additional weight) to the towing vehicle.

## Adjusting the Brush Height

**Important: Setting the brush height too low for sweeping conditions causes excessive wheel skipping and slipping. For best performance, adjust brush height as high as possible for the material and conditions.**

Normal lawn sweeping is accomplished when the brushes sweep at the same height as the mower cutting height.

To adjust brush height:

1. Park towing vehicle on a level, hard surface and set parking brake.
2. Turn towing vehicle off.
3. Measure the height of the of the mower blade.
4. Attach sweeper to the towing vehicle hitch plate as previously described.
5. Adjust Lock Arm (1) into a slot that allows the brushes to sweep at the same height as the mower blade:
  - a) Loosen (do not remove) Knob (31).
  - b) Apply light downward pressure to Height Adjustment Handle (2) while lifting up on Lock Arm (1).
  - c) Move Height Adjustment Handle (2) to the desired position and lower Lock Arm (1).
  - d) Tighten Knob (31) firmly.

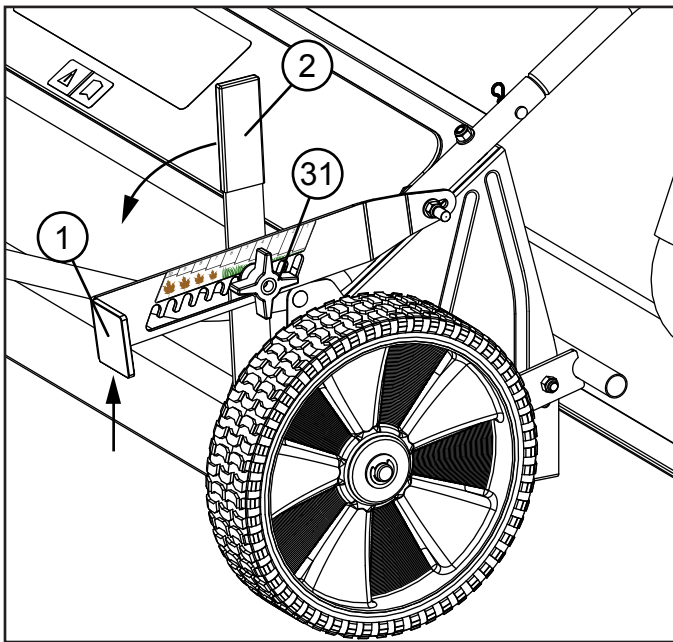

6. Check to be sure that the Hamper is not dragging on the ground and adjust as necessary (see 'Leveling the Hamper' section).

Higher numbers on the Lock Arm (1) decal indicate higher brush heights.

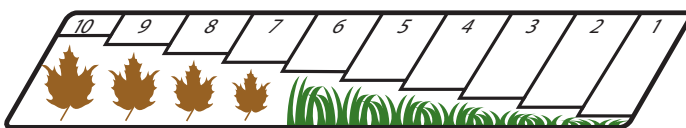

(41) 1009046 (Not to scale)

For best performance, brush height should be set to the highest possible number while still adequately sweeping the lawn.

It is recommended to set the brush height at a higher number than is anticipated to be needed and perform a short sweeping test on the lawn. Reduce brush height one setting at a time until the desired sweeping performance is achieved.

For reference:

Lock Arm Number	Approximate Brush Height	Sweeping Conditions
1 to 3	1/4" to 1" (6.5mm to 25mm)	Extremely low-cut grass and light material.
3 to 6	1" to 2" (25mm to 50mm)	Mowed lawns under normal conditions or light leaves
6 to 10	2" to 3-1/4" (50mm to 82mm)	High grass, heavy leaves or heavy grass clippings

**Note: Settings 1 to 3 should be used only on very short grass heights and light material.**

## Leveling the Hamper

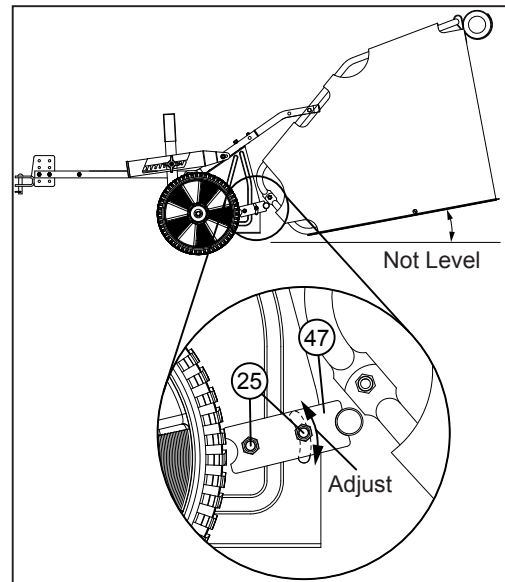

After correct brush height is determined, it may be necessary to adjust the Hamper Stop (47) so that the Hamper assembly remains clear of the ground.

To adjust the Hamper Stop (47):

1. Loosen (but do not remove) the two Nuts (25) securing each side of the Hamper Stop (47).  
The rear mounting holes are slotted, allowing the Hamper Stop (47) to be pivoted up or down for adjustment.
2. Move the Hamper Stop (47) up or down to adjust the resting position of the Hamper assembly so that it is approximately level.
3. Tighten Nuts (25) on each side to secure the Hamper Stop (47) in position.

If correct Hamper assembly adjustment is not possible, the Clevis Assembly (68) may need to be readjusted so that the Hamper assembly has adequate clearance to the ground.

The sweeper Tow Tubes should be parallel with the ground (or angled slightly forward) when the sweeper is connected to the towing vehicle. If the Tow Tubes are angled rearward, adjust the Tow Tube mounting holes on the Clevis Assembly (68) lower. This will angle the Tow Tubes forward and raise the Hamper assembly.

# OPERATION

## Operating Speed

The operating ground speed of the sweeper has a direct effect on how material is thrown into the hamper. Material will be thrown farther toward the back of the hamper as ground speed increases.

Operation speed will depend on the condition of the lawn and material being swept. Operate the sweeper at a ground speed that will throw material to the back of the hamper. Under normal conditions 3 mph (approximately the speed of a brisk walk or 40 feet in 9 seconds) works best.

Maximum operating speed is 5 mph.

## Emptying the Hamper



**Caution: Avoid Injury! Make sure area is clear of bystanders, especially children, before backing up.**

Before dumping material from the Hamper: Park towing vehicle and set parking brake (see owners manual).

**Important: Avoid overfilling the Hamper, especially when sweeping freshly mowed grass or other moist material. Heavy loads will be more difficult to dump.**

To empty Hamper:

1. Tow the sweeper to a location the material should be dumped.
2. Stop towing vehicle and set parking brake.
3. Pull Handle (35) and Rope (37) to tilt hamper forward/upward, allowing material to exit the opening at the front of the Hamper.
4. Replace Pull Handle (35) to Hook and Loop (36) fixed to the towing vehicle.

**Important: After dump operation is complete, confirm Pull Handle (35) is fully secured to the back of the towing vehicle. Pull Rope and Handle can get tangled in the sweeper brushes if they fall on the ground in front of the sweeper during operation.**

## Using the Wind Screen

The Hamper Wind Screen can be configured in two positions based on conditions and preference.

### Position 1 – Wind Screen Fully Open

Allow the Wind Screen to hang off the back of the Hamper. This condition Can be used when there is little to no wind; Operating speed should be slower to ensure material is not thrown over the Hamper.

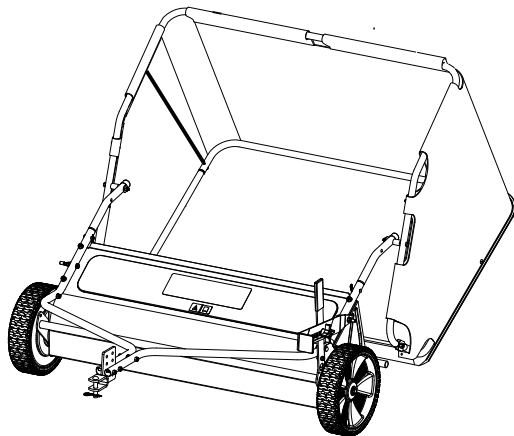

### Position 2 – Wind Screen Half Closed

Attach the Wind Screen to the Hamper Upper Side Tubes using the elastic straps on the ends of the Wind Screen.

Can be used in a medium wind to prevent material from blowing out of Hamper; Operating speed should be slower to ensure material is not thrown over the Hamper or Wind Screen.

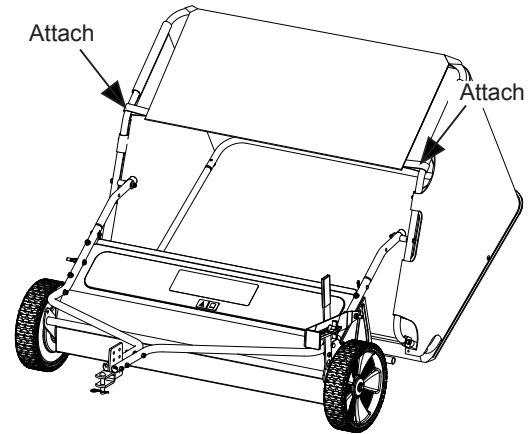

# OPERATION

## Storage

The sweeper can be tipped upright and stored against a wall using a minimum of space:

1. Remove any loose material from hamper, brushes, brush housing and drive assembly. The sweeper should be clean and dry before configuring for storage.
2. Remove small hairpin cotters and clevis pins that are securing the hamper assembly to the brush housing. Remove the hamper assembly. Replace the clevis pins and hairpin cotters in the hamper mount tubes for storage.
3. Collapse the hamper by unlocking the spreader bar assembly (push forward). Orientate the collapsed hamper so that the rear hamper tubes are up. Put rope and pull handle into the pocket created between the rear hamper tubes.
4. On sweeper, adjust brush height to position 10 on the Lock Arm
5. Roll sweeper to desired storage area. Lift clevis assembly vertically so that the sweeper is standing upright on the hamper mount tubes and hamper stop bar. Move close to the wall so that the top of the brushing housing faces the wall (brushes face out).
6. Position collapsed hamper between sweeper and wall and hang on the clevis assembly, from the middle of the rear hamper tube.

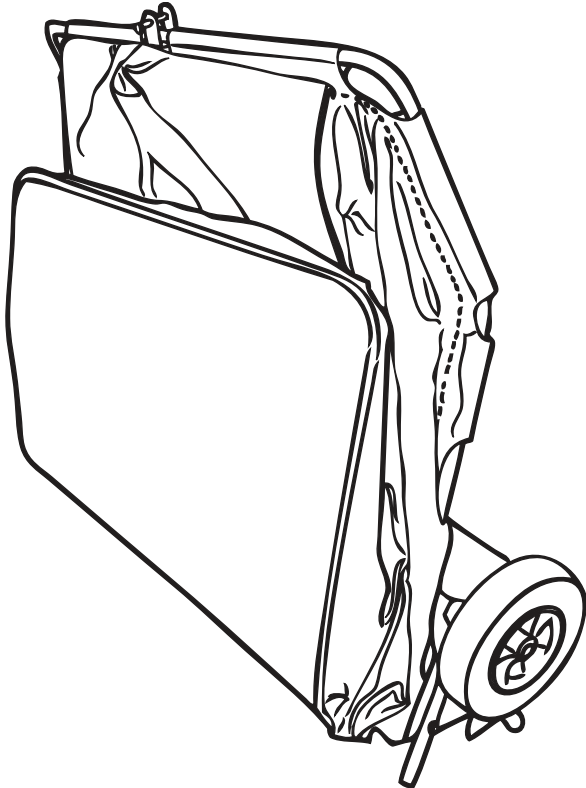

## Frequently Asked Questions

Sweeper does not pick up:

1. The brush height adjustment is set too low. The sweeper is not a dethatcher and cannot pull thatch, embedded needles or embedded leaves from deep in the grass. The brush height should be adjusted to the height of the mower deck blades.
2. The brush height adjustment is set too high. Lower the brush height one notch at a time on the lock arm until the desired performance is achieved.
3. There is a problem with the brush drive system. See the 'Sweeper Wheels' section below.

Grass or material goes over the top of the hamper:

1. Forward speed is too fast. Slow towing vehicle down. Best speed is 3 mph or less (3 mph = 40 feet in 9 seconds).
2. The wind screen can be used to remedy this concern. See the 'Using the Wind Screen' information in the 'OPERATION' section of this manual.

Sweeper Wheels (not moving, skipping or locking up):

1. The wheels are geared to turn the sweeper brushes. If the sweeper wheels are not moving, skipping or locking up; it is possible that the brush height is set too low. Measure the cut height of the mower. Adjust the brush height to sweep at the same level as the cut height.
2. The drive dowel(s) located inside the small metal drive pinion gear(s) are sticking. Remove, clean and lubricate the dowel(s), drive pinion gear(s) and brush axle as shown in the 'Preventative Maintenance' section of this manual.
3. The drive pinion gear(s) are worn and because of this it locks the drive dowel(s). Remove, inspect and replace the drive pinion gear(s) and drives dowel(s) as needed. See 'Preventative Maintenance' section of this manual.
4. The drive pinion gears, when re-installed, were installed backwards. For example: the right side gear was installed on the left side of the sweeper. See the 'Preventative Maintenance' section of this manual for proper drive pinion gear assembly.

Hamper drags on the ground:

1. The tow bars are not level with the ground when attached to the towing vehicle. Remove the clevis assembly and reinstall in a different set of mounting holes. The clevis can be turned over to get additional adjustment. See assembly 'Figure 02' and 'Leveling the Hamper' sections of this manual.

Hamper orientation is too high:

1. Hamper mount tubes are assembled upside down. See Figure 11 and confirm orientation of hamper mount tubes.

# MAINTENANCE

## Preventative Maintenance:

### General

1. Do not allow material to remain in the Hamper for extended periods of time. Clean the Hamper using a water hose and allow it to dry completely before storage.
2. Check all moving parts for wear and freedom of movement.
3. Check all fasteners for tightness and retighten as required.
4. Inspect for rust on painted surfaces. Sand lightly and touch up damaged areas with enamel paint.
5. Routine lubrication of the Dowel Pin and Drive Pinion is required. At a minimum it is recommended to do this twice per year: in the fall before storage, and again in the spring before the first use. Follow the procedure outlined below in the 'Wheel and Drive Gear' maintenance section.
6. Check the Drive Pinions and Dowel Pins for wear and replace as needed. These are considered normal wear parts. Contact the Customer Service Department to purchase replacement parts.
7. Lubricate the Wheel Axles annually following the procedure outlined in the Maintenance section.

### Brush Section Replacement

Note: This procedure will show an example for right side Brush Section (55) replacement. Reverse pull directions for left side Brush Section replacement.

Tools Needed:  
Safety Glasses, Work Gloves  
Rubber Mallet

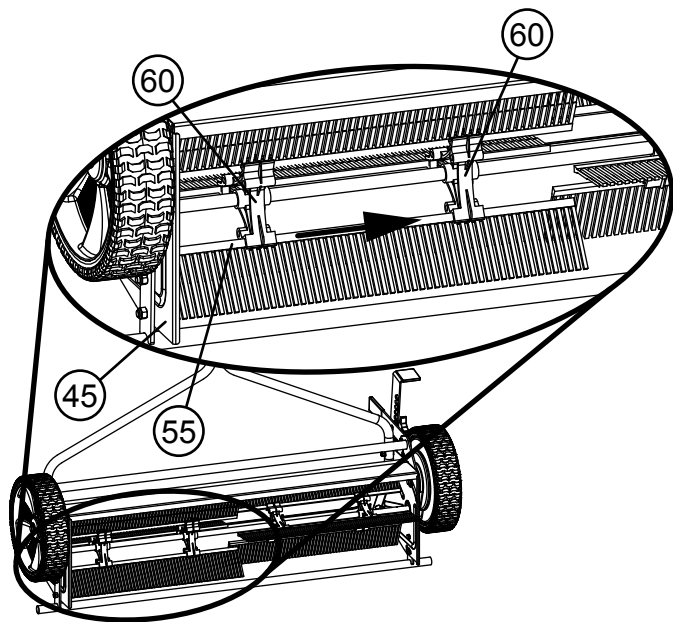

1. Stand the sweeper in storage position on a clean flat surface such as garage floor or sidewalk (do not hang hamper from clevis assembly).
2. Inspect the Brush Section and notice which side has the short bristles (these will be located near the metal rail of the Brush Section). It is important that the new Brush Section is assembled in the same orientation.
3. Using the rubber mallet, tap the metal rail of the Brush Section (55) to the left. This will loosen the Brush Section from the Brush Holders (60).
4. Wearing work gloves, firmly grasp the Brush Section (55) between the Brush Holders (60) and pull to the right. Continue to pull the Brush Section (55) to the right until it is free from both Brush Holders (60).

Note: It may be necessary to have a second person hold the sweeper in place while pulling the Brush Section (55) free.

5. Align the metal rail of the new Brush Section (55) with groove on inside Brush Holder (60). Note: Orientation of Brush Section (55) short bristles must be as observed in Step 2.
6. Tap Brush Section (55) into Brush Holder (60) using the rubber mallet.
7. Continue to tap Brush Section (55) into the first Brush Holder (60). Be sure to align the metal rail of the Brush Section (55) with the groove on the second Brush Holder (60).
8. Continue to tap Brush Section (55) into Brush Holders (60) until the metal rail aligns with the remaining two Brush Sections (55) or about 1/2 to 3/4 inch from Brush Housing (45) side panel.
9. Turn brush assembly and confirm there is no contact between the metal rail of the Brush Section (55) and the Brush Housing (45) side panel. If there is contact, pull the Brush Section (55) to the right until brush assembly spins freely.
10. Repeat as need for the remaining Brush Sections (55).

### Wheel and Drive Gear

**Important: Safety glasses should be worn while performing maintenance operations on the sweeper. Solvent proof gloves (rubber or latex), should be worn when using any cleaning or lubrication products.**

**Important: Drive Pinions (64 & 65) are Right and Left hand specific as indicated on the bottom surface of the part. Left hand Drive Pinion (64) is indicated with 'L' and right hand Drive Pinion is indicated with 'R'. Refer to the illustration below showing the right and left side of sweeper.**

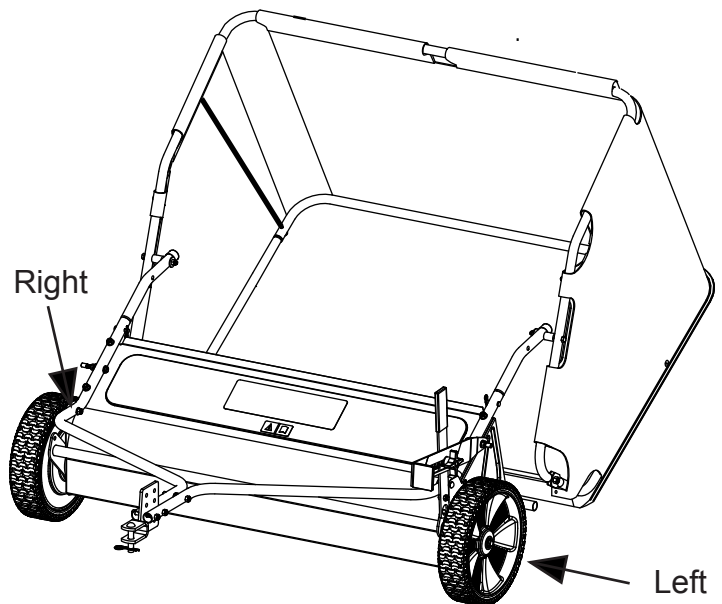

Tools Needed:

- Safety Glasses, Rubber or Latex Gloves
- Medium Flat Tip Screwdriver
- Retaining Ring Pliers (External)
- 7/16 inch Wrench
- 1/4 inch Wrench

# MAINTENANCE

## Wheel and Drive Gear

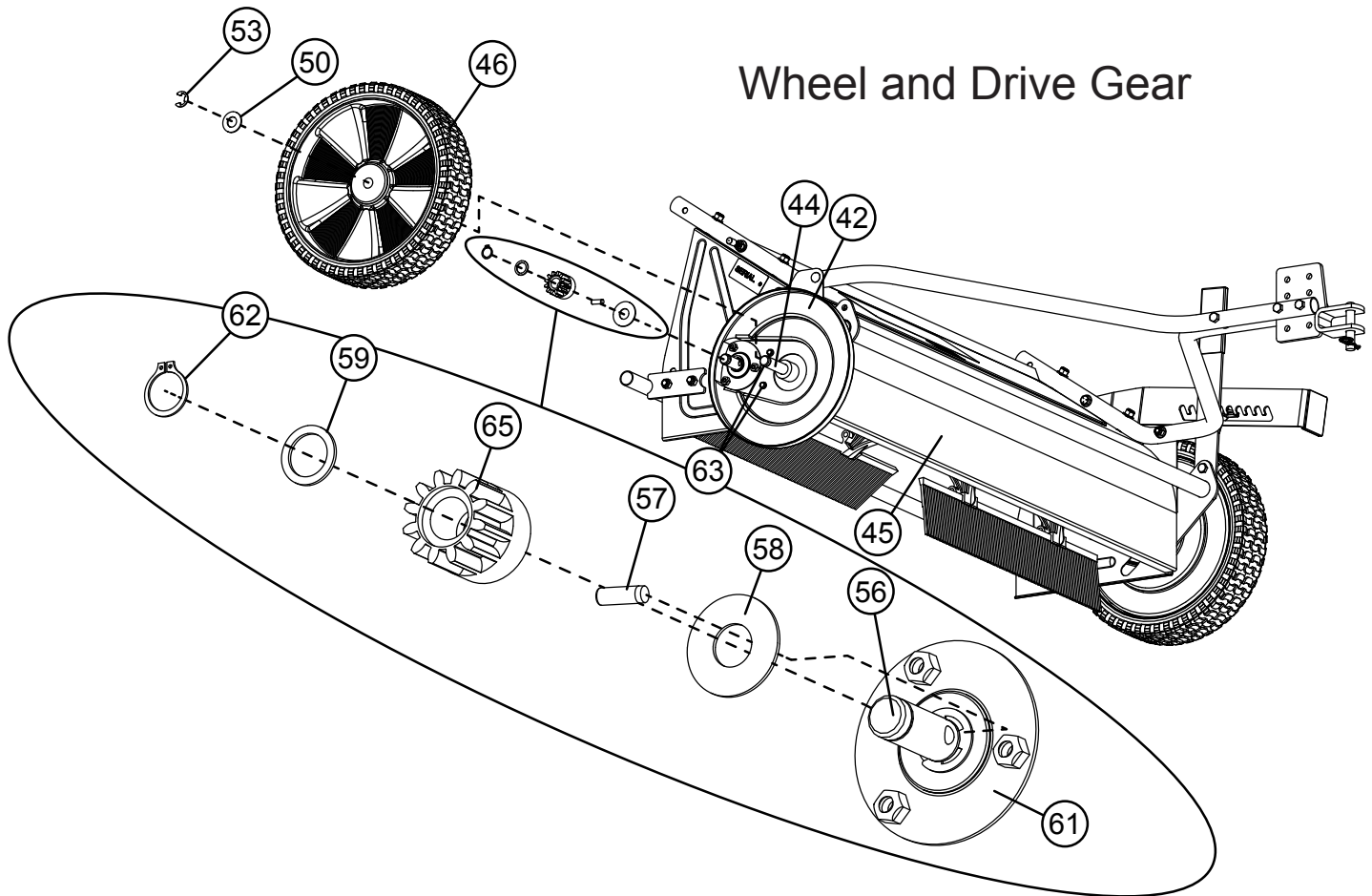

### Disassembly and Inspection

1. Stand the sweeper in storage position on a clean flat surface such as garage floor or sidewalk (do not hang hamper from clevis assembly)
2. Using a medium flat tip screwdriver, remove E-Ring (53)
3. Remove Machine Bushing (50) and Wheel (46)
4. Inspect Wheel gear and Wheel Axle hole for damage and wear
5. Inspect Wheel Axle (44) for damage and wear. Note: Wheel Axle (44) can be removed from the inside of the brush housing.
6. Clean any dirt or debris from the inside of the Wheel (46) and Dust Cover (42)
7. Confirm the Tapping Screws (63) holding the dust cover in place are not loose. Warning: Do not over tighten!
8. Remove Retaining Ring (62) from recess in drive pinion gear. This example shows the RH Drive Pinion or (65).
9. Remove Flat Washer (59) and Drive Pinion (65). Note: Cup one hand under the Drive Pinion during removal as the Dowel Pin (57) may fall free.
10. Inspect and clean the inside of the Drive Pinion. Note that the bottom of this gear has 'R' emboss into it, indicating the RH Drive Pinion.
11. Remove the Dowel Pin (57) from the Brush Axle (56) (if it has not already fallen free).
12. Inspect and clean the Dowel Pin
13. Inspect and clean the Dowel Pin hole on the brush axle. A small rag or paper towel can be used to clean the inside of the hole.
14. Remove the Large Flat Washer (58). Inspect and clean the washer and the area around the Brush Axle (56).

If Bearing Retainer (61) replacement is needed, continue with Step 15.

If Bearing Retainer (61) does not need replacement, continue at 'Assembly and Lubrication' section.

15. If Bearing Retainer (61) replacement is needed, remove Tapping Screws (63) and Dust Cover (42).
16. Remove E-Ring (53) using a medium flat tip screwdriver.
17. Remove the Lock Nuts (20) securing the Bearing Retainer. Note: Do not let the Carriage Bolts (48) fall out of the Lower Pivot (43) side plate.
18. Remove Bearing Retainer (61)

# MAINTENANCE

## Dust Cover and Bearing Retainer

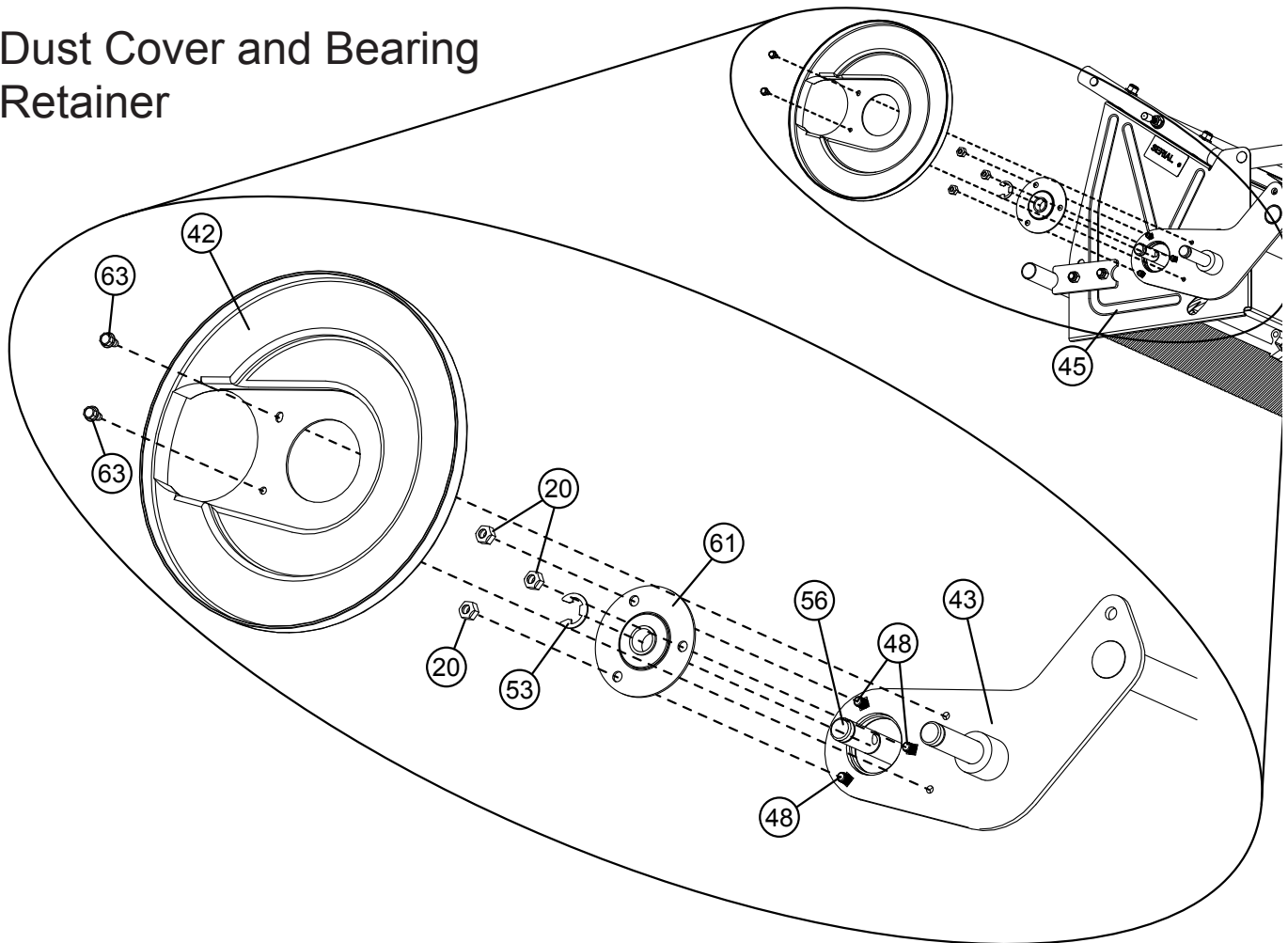

### Assembly and Lubrication

If Bearing Retainer (61) was removed, continue with Step 1. If Bearing Retainer (61) was not removed, begin at Step 5.

1. Insert new Bearing Retainer (61) onto Brush Axle (56). The Bearing Retainer (61) should fit flush on the Lower Pivot (43) side plate with the Bearing Retainer (61) flange fitting inside the hole in the Lower Pivot (43) side plate and hole in the Brush Housing (45).  
Note: Take care when assembling the new Bearing Retainer (61) so that Carriage Bolts (48) remain in Lower Pivot (43) side plate.
2. Assemble the 3 Lock Nuts (20) securing the Bearing Retainer (61). Tighten all three Lock Nuts (20).
3. Snap E-Ring (53) into place on the Brush Axle (56). Note: Be sure E-Ring is fully engaged with groove on Brush Axle (56).
4. Assemble the Dust Cover (42) to the Lower Pivot (43) side plate using the Tapping Screws (63). Warning: Do not over tighten!
5. Apply WD40, 3 in 1 oil or other similar light lubricant directly to the inside of the Dowel Pin hole.
6. Replace the Large Flat Washer (58) onto the Brush Axle (56) until it touches the Bearing Retainer (61).
7. Turn the Brush Axle (56) so that the Dowel Pin hole is horizontal with the ground.
8. Apply WD40, 3 in 1 oil or other similar light lubricant to the Dowel Pin (57) and insert into the Dowel Pin hole on the Brush Axle (56). Note: center the Dowel Pin (57) so that an even amount is showing on both sides of the Brush Axle (56).
9. Insert the Drive Pinion (65) onto Brush Axle until it touches the Large Flat Washer (58). Note: Dowel Pin (57) will now be inside the Drive Pinion (65).
10. Insert Flat Washer (59) over the Brush Axle (56) and into the recess on the Drive Pinion (65).
11. Assemble the Retaining Ring (62) onto the Brush Axle (56). Be sure that the Retaining Ring (62) is fully engaged with the groove on the Brush Axle (56).
12. If removed, replace the Wheel Axle (44) from the inside of the Brush Housing (45).
13. Apply a light coating of general purpose axle oil/grease to the Wheel Axle (44).
14. While holding the Wheel Axle (44) on the inside of the Brush Housing (45), insert the Wheel (46) onto the Wheel Axle (44). Note: wheel may have to be turned slightly to engage Wheel gear with Drive Pinion gear.
15. Replace the Machine Bushing (50) and snap E-Ring (53) into place on Wheel Axle (44). Note: Be sure E-Ring is fully engaged with groove on Wheel Axle (44).

Repeat for left side Wheel and Drive Gear service.

# BLANK PAGE

---

---

**MANUFACTURER'S LIMITED WARRANTY  
FOR**



The limited warranty set forth below is given by Brinly-Hardy Company with respect to new merchandise purchased and used in the United States, its possessions and territories.

Brinly-Hardy Company warrants the products listed below against defects in material and workmanship, and will at its option, repair or replace, free of charge, any part found to be defective in materials or workmanship. This limited warranty shall only apply if this product has been assembled, operated, and maintained in accordance with the Operator's manual furnished with the product, and has not been subject to misuse, abuse, commercial use, neglect, accident, improper maintenance, alteration, vandalism, theft, fire, water, or damage because of other peril or natural disaster.

Normal Wear Parts or components thereof are subject to separate terms as follows: All normal wear parts or component failures will be covered on the product for a period of 90 days.

Parts found to be defective within the warranty period will be replaced at our expense. Our obligation under this warranty is expressly limited to the replacement or repair, at our option, of parts found to be defective in material and workmanship.

**HOW TO OBTAIN SERVICE:** Warranty parts replacements are available, ONLY WITH PROOF OF PURCHASE, through our Customer Service Department. Call 877-728-8224.

This limited warranty does not provide coverage in the following cases:

- a) Routine maintenance items such as lubricants and filters.
- b) Normal deterioration of the exterior finish due to use or exposure.
- c) Transportation and/or labor charges.
- d) The warranty does not include commercial and/or rental use.

**No implied warranty, including any implied warranty of merchantability of fitness for a particular purpose, applies after the applicable period of express written warranty above as to the part as identified below. No other express warranty whether written or oral, except as mentioned above, given by any person or entity, including a dealer or retailer, with respect to any product, shall bind Brinly-Hardy Co. During the period of the warranty, the exclusive remedy is repair or replacement of the product as set forth above.**

**The provisions as set forth in this warranty provide the sole and exclusive remedy arising from the sale. Brinly-Hardy Co. shall not be liable for incidental or consequential loss**

**or damage including, without limitation, expenses incurred for substitute or replacement lawn care services or for rental expenses to temporarily replace a warranted product.**

Some states do not allow the exclusion or limitation of incidental or consequential damages, or limitations on how long an implied warranty lasts, so the above exclusions or limitations may not apply to you.

During the warranty period, the exclusive remedy is replacement of the part. In no event shall recovery of any kind be greater than the amount of the purchase price of the product sold. Alteration of safety features of the product shall void this warranty. You assume the risk and liability for loss, damage, or injury to you and your property and/or to others and their property arising out of the misuse or inability to use this product.

This limited warranty shall not extend to anyone other than the original purchaser or to the person for whom it was purchased as a gift.

**HOW STATE LAW RELATES TO THIS WARRANTY:** This limited warranty gives you specific legal rights, and you may also have other rights which vary from state to state.

**IMPORTANT:** The Warranty period stated below begins with the PROOF OF PURCHASE. Without the proof of purchase, the Warranty period begins from the date of manufacture determined by the serial number manufacturing date.

**WARRANTY PERIOD:**

The warranty period for the product shown in this manual is as follows: Steel Frame Parts: 2 Years. Tires, Wheels and Drive are normal wear parts - 90 days.