

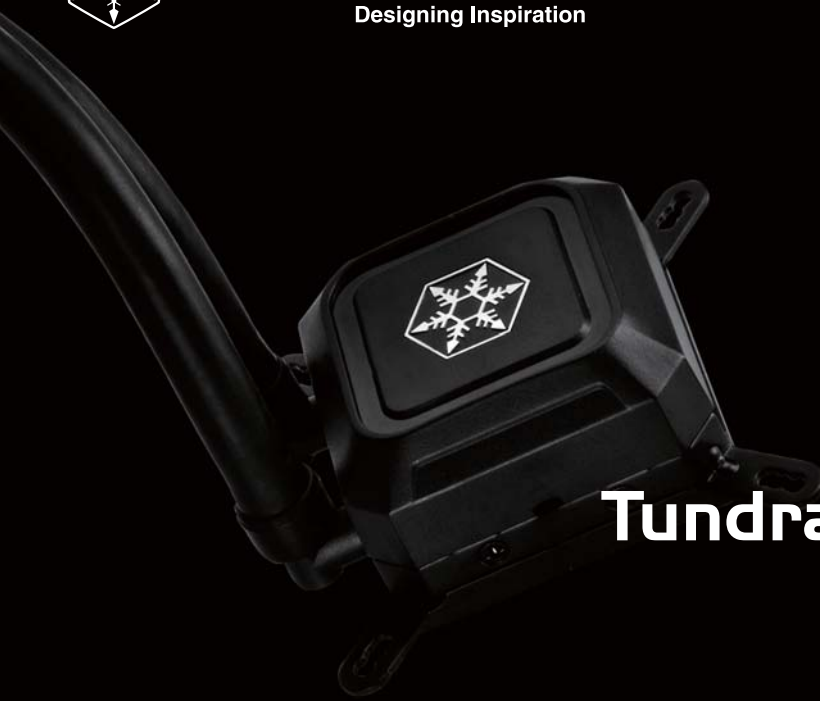

SILVERSTONE[®]
Designing Inspiration



Tundra series MANUAL

Installation and system optimization guide:

The following manual and guides were carefully prepared by the SilverStone engineering team to help you maximize the potential of your SilverStone product. Please keep this manual for future reference when upgrading or performing maintenance on your system. A copy of this manual can also be downloaded from our website at:

<http://www.silverstonetek.com>

Specification & Disassemble chart ————— P.2















INTEL ————— P.3

AMD ————— P.9

Tundra series

Durable high performance all-in-one Liquid Cooler

Specification & Disassemble chart

Model No.	SST-TD02-SLIM / SST-TD03-SLIM		Radiator	Material	Aluminum		
Water block	Dimension	65mm (L) x 65mm (W) x 39.5mm (H)	Tube	Length	310mm		
	Material	Copper base with plastic body		Material	Rubber		
Pump	Motor speed	2500±10%RPM	Application	Intel Socket LGA775/115X/1366/2011-V3			
	Rated Voltage	12V		AMD Socket AM2/AM3/FM1/FM2			
	Rated Current	0.35A					
Fan	Dimension	120mm (L) x 120mm (W) x 15mm (D)					
	Speed	800 ~ 2200 RPM					
	Noise level	16.5 ~ 27.4 dBA					
	Rated Voltage	12V					
	Rated Current	0.02 ~ 0.15 A					
	Max airflow	13.1 ~ 35.86 CFM					
	Pressure	0.31 ~ 1.84 mmH2O					
	Connector	4 Pin PWM					
Radiator	Dimension	TD02-SLIM, 273mm(L)x120mm(W)x22mm(H)					
		TD03-SLIM, 153mm(L)x120mm(W)x22mm(H)					

ENGLISH

Secure the fan together with the radiator onto the chassis.

DEUTSCH

Lüfter gemeinsam mit dem Kühlkörper am Gehäuse anbringen.

FRANÇAIS

Fixez le ventilateur au radiateur sur le châssis.

ESPAÑOL

Fije el ventilador junto con el radiador en el chasis.

ITALIANO

Fissare la ventola al radiatore sul telaio.

РУССКИЙ

Закрепите вентилятор с радиатором на шасси.

繁體中文

將風扇與水冷排鎖在機殼上

簡體中文

将风扇与水冷排锁在机壳上

日本語

ファンをラジエーターと共にケースに固定します。

한국어

팬과 라디에이터를 케이스에 고정합니다.

Fan screw A

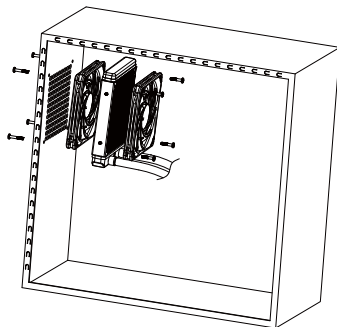

TD03-SLIM

Fan screw B

Fan screw A

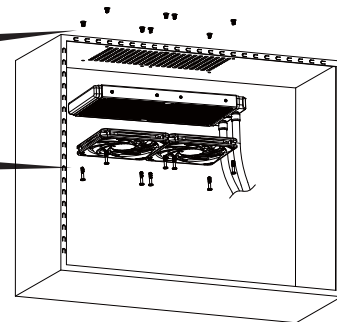

TD02-SLIM

ENGLISH

Make sure you are using the correct side of the back plate for your motherboard and insert the screw into the correct holes based on the CPU socket you use.

*Insert the square spacer into the center hole on the back plate for LGA775.

DEUTSCH

Sicherstellen, dass Sie die richtige Seite der Rückplatte für Ihr Motherboard verwenden; Schrauben entsprechend dem von Ihnen verwendeten CPU-Sockel in die richtigen Löcher stecken.

*Setzen Sie bitte nur bei dem Sockel 775 die Schraubbegrenzungen zentrisch auf die Lochführung der Backplate.

FRANÇAIS

Assurez-vous d'utiliser le bon côté de la plaque arrière de votre carte mère et insérez les vis dans les bons trous situés sur la fiche CPU que vous utilisez.

*Seulement dans le cas d'une installation pour Socket LGA 775, veiller à disposer le carré de mousse au centre de la plaque arrière.

ESPAÑOL

Asegúrese de que está usando el lado correcto de la placa trasera para su placa base e inserte los tornillos en los agujeros correctos basándose en el zócalo de CPU que usa.

*Utilice el espaciador cuadrado en el centro del andaje, únicamente cuando se trate de socket LGA775.

ITALIANO

Assicurarsi di usare il lato corretto della piastra posteriore della scheda madre e di inserire la vite nei fori corretti in base al socket CPU che si usa.

*Inserire il distanziatore quadrato nel foro centrale della piastra solo con l'installazione LGA775.

РУССКИЙ

Проверьте правильность использования опорной прокладки для системной платы и установите винты в надлежащие отверстия на соquete процессора.

*Установите квадратный вкладыш по середине монтажной пластины (для INTEL только).

繁體中文

確定背板正確的使用面，將螺柱依CPU平臺類型插入背板對應的孔位。

*安裝LGA775主機板時，須先將方形墊板壓入背板中心孔。LGA115X/1366主機板則不需要。

簡體中文

確定背板正確的使用面，將螺柱依CPU平臺類型插入背板對應的孔位。

*安裝LGA775主機板時，須先將方形墊板壓入背板中心孔。LGA115X/1366主機板則不需要。

日本語

お持ちのマザーボードに対して正しい側のバックプレートを使用していることを確認し、ご使用のCPUソケットに基づいて正しい穴にネジを装着してください。

※LGA775のインストールにのみ、角型スペーサーをバックプレートの中心の穴に装着してください。

한국어

메인보드에서 백 플레이트의 올바른 면을 사용했는지 확인하고 사용 중인 CPU 소켓에 맞춰 나사를 올바른 구멍에 삽입합니다.

*사각 스페이서를 LGA775만 설치된 백보드의 중심 구멍에 끼우십시오.

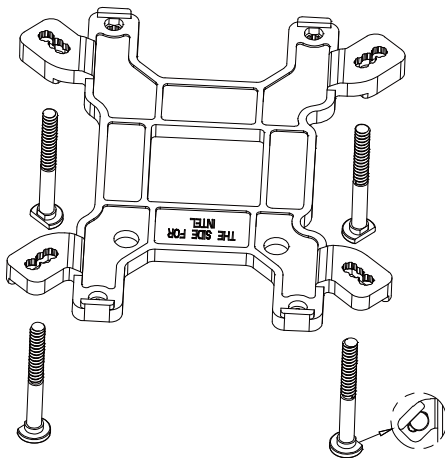
LGA775

ENGLISH

Install the back plate assembly onto the motherboard and slip on the screw standoffs.

DEUTSCH

Installieren Sie die Backplate auf der Mainboard Unterseite und ziehen Sie die Abstandshalter von oben über die Schrauben.

FRANÇAIS

Installer la plaque arrière sous la carte mère et y apposer les entretoises.

ESPAÑOL

Coloque la sujeción por detrás de la placa base y deslicela sobre los tornillos.

ITALIANO

Installare la piastra sulla scheda madre ed installare il distanziatore.

РУССКИЙ

Закрепите монтажную пластину к материнской плате.

繁體中文

將背板組件裝入主板孔位，套入4pcs圓柱固定。

簡體中文

將背板組件裝入主板孔位，套入4pcs圓柱固定。

日本語

マザーボードにバックプレートセットをインストールして、スペーサーの上に設置します。

한국어

백보드 세트를 메인보드에 설치하고 스탠드오프 위에서 미십시오.

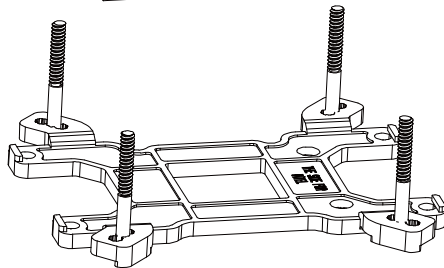
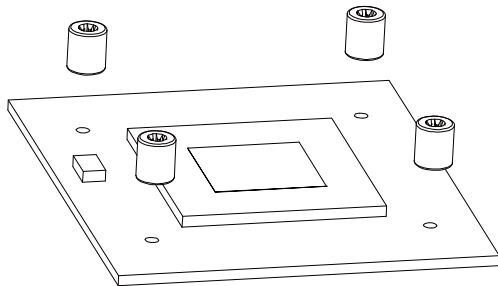

※LGA775/115X/1366

ENGLISH

Mount LGA2011 and INTEL clips and tighten the nuts.

DEUTSCH

Setzen Sie die LGA2011 und Intel Clips auf die Schrauben und verschrauben Sie diese mit den Schraubmuttern.

FRANÇAIS

Monter les plaques de fixation pour processeur LGA2011 et INTEL, et serrer les écrous.

ESPAÑOL

Monte los clips de LGA2011, INTEL y ajuste las tuercas.

ITALIANO

Installare i dispositivi di fissaggio LGA2011 ed INTEL e stringere i dadi.

РУССКИЙ

Установите интеловские зажимы и закрепите винты.

繁體中文

裝入 INTEL 扣具，將 4 顆螺絲順時針拧紧固定。

裝入 LGA2011 螺絲及 INTEL 扣具，將 4 顆螺絲順時針拧紧固定。

簡體中文

裝入 INTEL 扣具，將 4 顆螺絲順時針拧紧固定。

裝入 LGA2011 螺絲及 INTEL 扣具，將 4 顆螺絲順時針拧紧固定。

日本語

LGA2011 と INTEL クリップを取り付けて、ナットを締めます。

한국어

LGA2011 과 INTEL 클립을 장착하고 너트를 조이십시오.

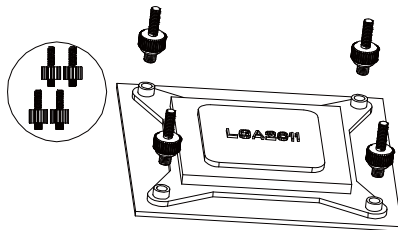

※LGA2011

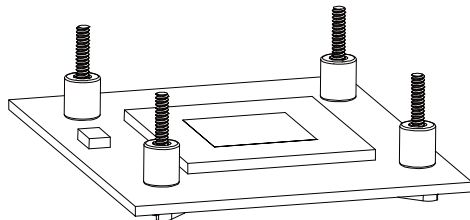

※LGA775/115X/1366

ENGLISH

Please clean the surface of CPU before applying thermal grease evenly on the CPU.

DEUTSCH

Reinigen Sie bitte die Oberfläche der CPU bevor Sie die Wärmeleitpaste gleichmäßig auftragen.

FRANÇAIS

Nettoyer la surface du CPU avant d'appliquer la pâte thermique, puis appliquer la pâte uniformément sur le CPU.

ESPAÑOL

Por favor, limpie la superficie del microprocesador antes de aplicar la pasta termica, Una vez limpio, aplíquela de manera uniforme sobre la CPU.

ITALIANO

Pulire la superficie della CPU prima di applicare la pasta termica e quindi applicare pasta termica in modo uniforme sulla CPU.

РУССКИЙ

На очищенную поверхность процессора равномерно нанесите термопасту.

繁體中文

將導熱膏均勻塗在CPU表面

簡體中文

將導熱膏均勻塗在CPU表面

日本語

サーマルグリスを塗る前に、CPUの表面を清潔にして、CPU上にサーマルグリスを均一に塗ります。

한국어

써멀 그리스를 바르기 전에 CPU 표면을 청소한 후 써멀 그리스를 CPU에 고르게 바르십시오.

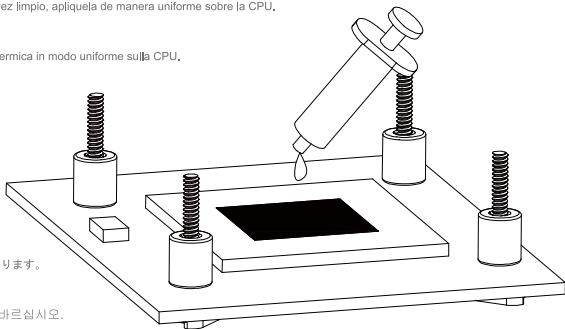

ENGLISH

Remove the film from the waterblock's base and place it on the CPU.

DEUTSCH

Folie von der Wasserblock-Basis entfernen, diese an der CPU anbringen.

FRANÇAIS

Retirez le film de la base du réservoir d'eau et placez-le sur le CPU.

ESPAÑOL

Retire la película de la base del bloque de agua y colóquelo en la CPU.

ITALIANO

Rimuovere la pellicola dalla base del waterblock e collocarlo sulla CPU.

РУССКИЙ

Снимите пленку с основания водерблока (водяного радиатора) и установите его на процессор.

繁體中文

撕掉水冷頭底部保護貼紙，再將水冷裝置放置CPU中間。

簡體中文

撕掉水冷頭底部保護貼紙，再將水冷裝置放置CPU中間。

日本語

液冷ブロックのベースからフィルムを剥がしてからCPUの上に設置します。

한국어

워터 블록 받침대에서 필름을 제거하고 받침대를 CPU에 올려 놓습니다.

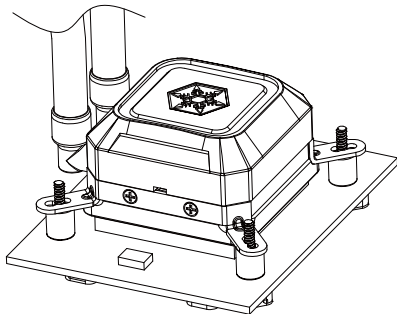
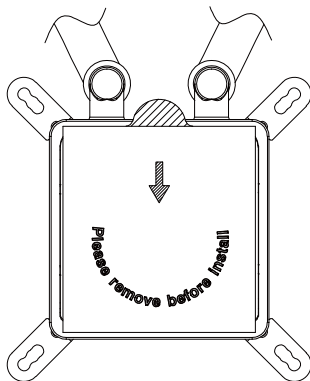

ENGLISH

Secure the spring screws onto the screws with a screwdriver.

DEUTSCH

Federschrauben mit einem Schraubendreher an den Schrauben befestigen.

FRANÇAIS

Fixez les vis à ressort sur les vis à l'aide du tournevis.

ESPAÑOL

Fije los resortes a los tornillos con un destornillador.

ITALIANO

Fissare le viti a molla in corrispondenza delle viti con un cacciavite.

РУССКИЙ

С помощью отвертки затяните пружинные винты.

繁體中文

將彈簧螺絲對準螺柱，用螺絲起子鎖緊。

簡體中文

将弹簧螺丝对准螺柱，用螺丝起子锁紧。

日本語

ドライバーでスプリングスクリューをネジの上に取り付けます。

한국어

스크루드라이버를 사용하여 스프링 나사를 나사에 고정합니다.

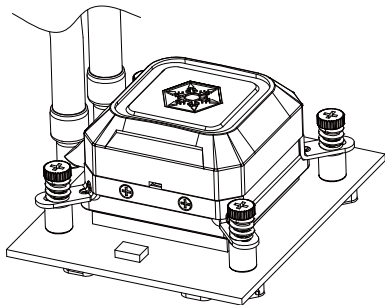
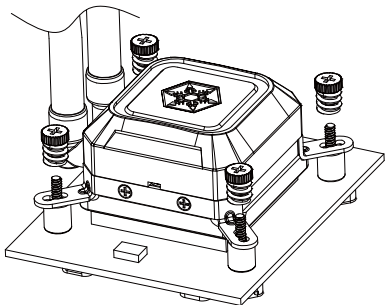

ENGLISH

Connect the waterblock and fan connectors onto the relevant motherboard connectors, installation complete.

DEUTSCH

Wasserblock- und Lüfteranschlüssen mit den entsprechenden Motherboard-Anschlüssen verbinden; damit ist die Installation abgeschlossen.

FRANÇAIS

Connectez le réservoir d'eau et les connecteurs du ventilateur sur les connecteurs de la carte mère correspondants, pour terminer l'installation.

ESPAÑOL

Conecte el bloque de agua y los conectores del ventilador en los conectores relevantes de la placa base, instalación completa.

ITALIANO

Collegare i connettori del waterblock e della ventola ai relativi connettori della scheda madre, l'installazione è completa.

РУССКИЙ

Подключите разъемы водоблока и вентилятора в соответствующие гнезда системной платы. Установка закончена.

繁體中文

將水冷頭與風扇端子插入主機板相應接口位置，完成安裝。

簡體中文

將水冷頭與風扇端子插入主機板相應接口位置，完成安裝。

日本語

液冷ブロックおよびファンコネクタを対応したマザーボードコネクタに接続すると、設置は完了です。

한국어

워터 블록과 팬 커넥터를 해당 메인보드 커넥터에 연결하면 설치가 완료됩니다.

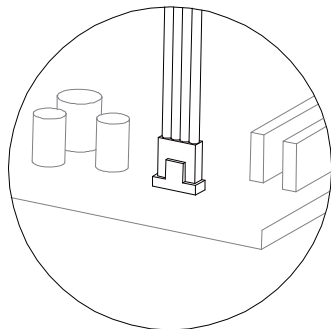

ENGLISH

Secure the spring screws onto the screws with a screwdriver.

DEUTSCH

Federschrauben mit einem Schraubendreher an den Schrauben befestigen.

FRANÇAIS

Fixez les vis à ressort sur les vis à l'aide du tournevis.

ESPAÑOL

Fije los resortes a los tornillos con un destornillador.

ITALIANO

Fissare le viti a molia in corrispondenza delle viti con un cacciavite.

РУССКИЙ

С помощью отвертки затяните пружинные винты.

繁體中文

將彈簧螺絲對準螺柱，用螺絲起子鎖緊。

簡體中文

将弹簧螺丝对准螺柱，用螺丝起子锁紧。

日本語

ドライバーでスプリングスクリューをネジの上に取り付けます。

한국어

스크루드라이버를 사용하여 스프링 나사를 나사에 고정합니다.

Fan screw A

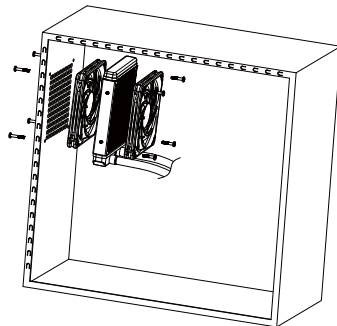

TD03-SLIM

Fan screw B

Fan screw A

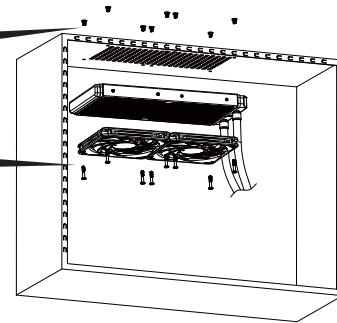

TD02-SLIM

ENGLISH

Place the insulation pads on the appropriate position. Check the holes of motherboard before installation and insert the screws into the corresponding holes of back plate.

DEUTSCH

Isolierungsauflagen an der entsprechenden Stelle anbringen. Löcher des Motherboards vor Installation prüfen, Schrauben in die entsprechenden Löcher an der Rückplatte einstecken.

FRANÇAIS

Placez les coussinets d'isolation dans la position appropriée. Vérifiez les trous de la carte mère avant installation et insérez les vis dans les trous correspondants de la plaque arrière.

ESPAÑOL

Sitúe las almohadillas de aislamiento en la posición apropiada. Compruebe los agujeros de la placa base antes de la instalación e inserte los tornillos en los agujeros correspondientes de la placa trasera.

ITALIANO

Collocare le piastre di isolamento sulla posizione appropriata. Controllare i fori della scheda madre prima dell'installazione ed inserire le viti nei fori corrispondenti della piastra.

РУССКИЙ

Поместите в соответствующие места изоляционные прокладки. Перед установкой проверьте отверстия на системной плате и вставьте винты в соответствующие отверстия опорной платы.

繁體中文

確定背板正確的使用面，壓入方型墊片，將4片絕緣貼片貼於相應位置，再將螺桿插入其對應的孔位。

简体中文

确定背板正确的使用面，压入方型垫片。将4片绝缘贴片贴于相应位置，再将螺杆插入其对应的孔位。

日本語

絶縁パッドを適切な場所に置きます。設置前にマザーボードの穴を確認してから、バックプレートの対応する穴にネジを装着します。

한국어

절연 패드를 적절한 위치에 배치합니다. 설치하기 전에 메인보드의 구멍을 확인하고 백 플레이트의 해당 구멍에 나사를 삽입합니다.

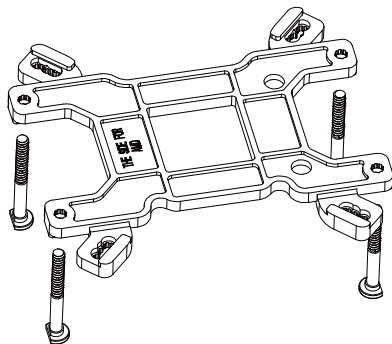

ENGLISH

Install the back plate assembly onto the motherboard and slip on the standoff.

DEUTSCH

Installieren Sie die Backplate auf der Mainboard Unterseite und ziehen Sie die Abstandhalter von oben über die Schrauben.

FRANÇAIS

Installer la plaque arrière sous la carte mère et y apposer les entretoises.

ESPAÑOL

Coloque la sujeción por detrás de la placa base y deslicela sobre los tornillos.

ITALIANO

Installare la piastra sulla scheda madre ed installare il distanziatore.

РУССКИЙ

Закрепите монтажную пластину к материнской плате.

繁體中文

再將背板組件裝入主機板孔位 (若主機板載有原扣具則需取掉)，套入圓柱固定。

簡體中文

再将背板组件装入主机板孔位 (若主机板载有原扣具则需取掉)，套入圆柱固定。

日本語

マザーボードにバックプレートセットをインストールして、スペーサーの上に設置します。

한국어

백보드 세트를 메인보드에 설치하고 스탠드오프 위에서 미십시오.

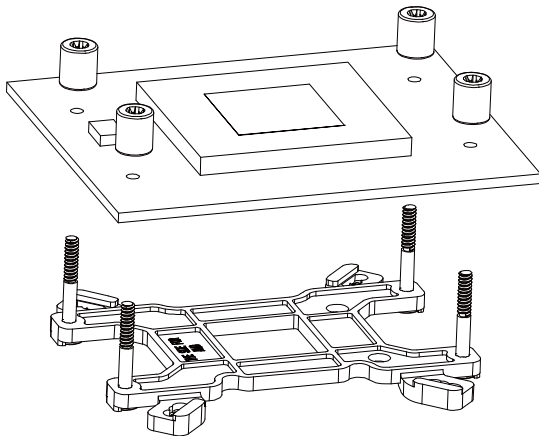

ENGLISH

Please clean the surface of CPU then apply thermal grease evenly on CPU.

DEUTSCH

Reinigen Sie bitte die Oberfläche der CPU bevor Sie die Wärmeleitpaste gleichmäßig auftragen.

FRANÇAIS

Nettoyer la surface du CPU avant d'appliquer la pâte thermique, puis appliquer la pate uniformément sur le CPU.

ESPAÑOL

Pulire la superficie della CPU prima di applicare la pasta termica e quindi applicare

ITALIANO

Collocare le piastre di isolamento sulla posizione appropriata. Controllare i fori della scheda madre prima dell'installazione ed inserire le viti nei fori corrispondenti della piastra.

РУССКИЙ

На очищенную поверхность процессора равномерно нанесите термопасту.

繁體中文

將導熱膏均勻塗在CPU表面

簡體中文

將導熱膏均勻塗在CPU表面

日本語

サーマルグリスを塗る前に、CPUの表面を清潔にして、CPU上にサーマルグリスを均一に塗ります。

한국어

씨얼 그리스를 바르기 전에 CPU 표면을 청소한 후 씨얼 그리스를 CPU에 고르게 바르십시오.

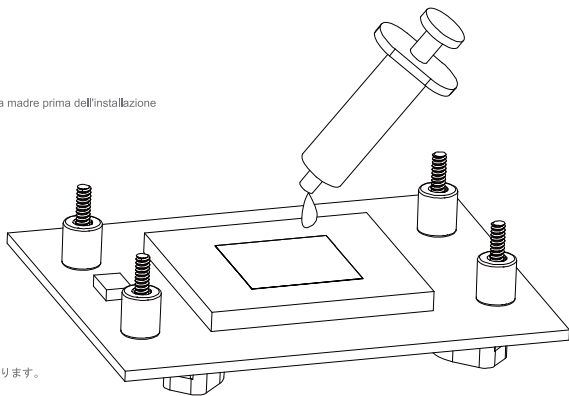

ENGLISH

Remove the INTEL clips and install the AMD clips.

DEUTSCH

INTEL-Klemmen entfernen und AMD-Klemmen installieren.

FRANÇAIS

Enlevez les clips INTEL et installez les clips AMD.

ESPAÑOL

Retire los enganches INTEL e instale los enganches AMD.

ITALIANO

Rimuovere le clip INTEL ed installare le clip AMD.

РУССКИЙ

Снимите фиксаторы INTEL и установите фиксаторы AMD.

繁體中文

將INTEL扣具拆下，再把AMD扣具裝上。

簡體中文

將INTEL扣具拆下，再把AMD扣具裝上。

日本語

INTELクリップを外してからAMDクリップを取り付けます。

한국어

INTEL 클립을 제거하고 AMD 클립을 설치합니다.

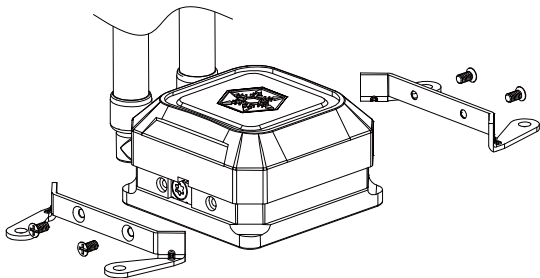
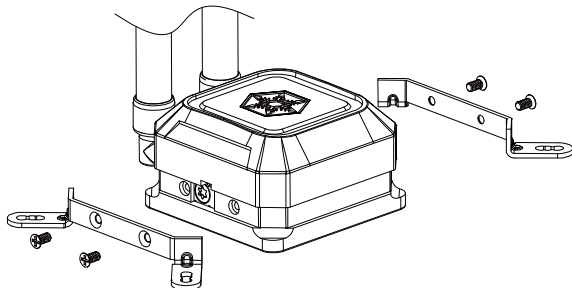

ENGLISH

Remove the film from the waterblock's base and place it on the CPU.

DEUTSCH

Folie von der Wasserblock-Basis entfernen, diese an der CPU anbringen.

FRANÇAIS

Retirez le film de la base du réservoir d'eau et placez-le sur le CPU.

ESPAÑOL

Retire la película de la base del bloque de agua y colóquelo en la CPU.

ITALIANO

Rimuovere la pellicola dalla base del waterblock e collocarlo sulla CPU.

РУССКИЙ

Снимите пленку с основания ватерблока (водяного радиатора) и установите его на процессор.

繁體中文

撕掉水冷頭底部保護貼紙，再將水冷裝置放置CPU中間。

簡體中文

撕掉水冷頭底部保護貼紙，再將水冷裝置放置CPU中間。

日本語

液冷ブロックのベースからフィルムを剥がしてからCPUの上に設置します。

한국어

워터 블록 받침대에서 필름을 제거하고 받침대를 CPU에 올려 놓습니다.

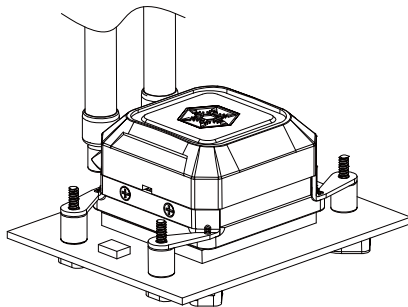
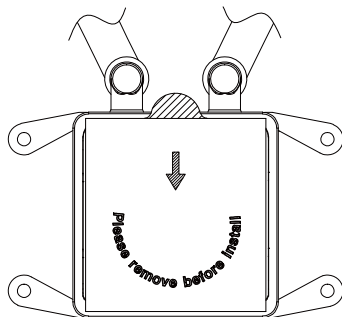

ENGLISH

Secure the spring screws onto the screws with a screwdriver.

DEUTSCH

Federschrauben mit einem Schraubendreher an den Schrauben befestigen.

FRANÇAIS

Fixez les vis à ressort sur les vis à l'aide du tournevis.

ESPAÑOL

Fije los resortes a los tornillos con un destornillador.

ITALIANO

Fissare le viti a molla in corrispondenza delle viti con un cacciavite.

РУССКИЙ

С помощью отвертки затяните пружинные винты.

繁體中文

將彈簧螺絲對準螺柱，用螺絲起子鎖緊

簡體中文

将弹簧螺丝对准螺柱，用螺丝起子锁紧

日本語

ドライバーでスプリングスクリューをネジの上に取り付けます。

한국어

스크루드라이버를 사용하여 스프링 나사를 나사에 고정합니다.

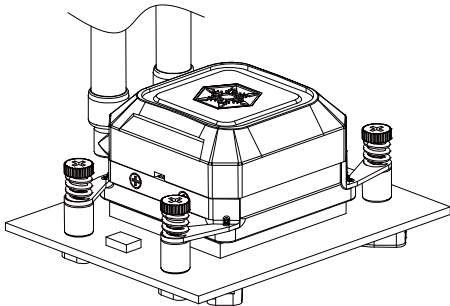
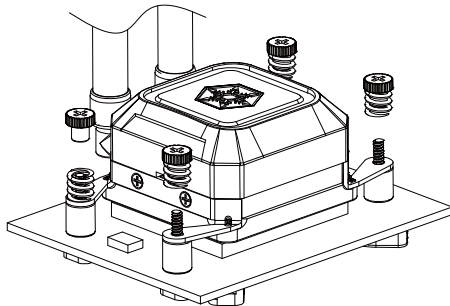

ENGLISH

Connect the waterblock and fan connectors onto the relevant motherboard connectors, installation complete.

DEUTSCH

Wasserblock- und Lüfteranschlüssen mit den entsprechenden Motherboard-Anschlüssen verbinden; damit ist die Installation abgeschlossen.

FRANÇAIS

Connectez le réservoir d'eau et les connecteurs du ventilateur sur les connecteurs de la carte mère correspondants, pour terminer l'installation.

ESPAÑOL

Conecte el bloque de agua y los conectores del ventilador en los conectores relevantes de la placa base, instalación completa.

ITALIANO

Collegare i connettori del waterblock e della ventola ai relativi connettori della scheda madre, l'installazione è completa.

РУССКИЙ

Подключите разъемы ватерблока и вентилятора в соответствующие гнезда системной платы. Установка закончена.

繁體中文

將水冷頭與風扇端子插入主機板相應接口位置，完成安裝。

簡體中文

将水冷头与风扇端子插入主机板相应接口位置，完成安装。

日本語

液冷ブロックおよびファンコネクタを対応したマザーボードコネクタに接続すると、設置は完了です。

한국어

워터 블록과 팬 커넥터를 해당 메인보드 커넥터에 연결하면 설치가 완료됩니다.

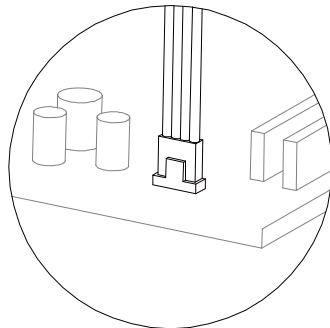

Warranty Information

This product has a limited 2 year warranty in North America, Europe, and Australia.

For information on warranty periods in other regions, please contact your reseller or SilverStone authorized distributor.

Warranty terms & conditions

1. Product component defects or damages resulted from defective production is covered under warranty.

Defects or damages with the following conditions will be fixed or replaced under SilverStone Technology's jurisdiction.

- a) Usage in accordance with instructions provided in this manual, with no misuse, overuse, or other inappropriate actions.
- b) Damage not caused by natural disaster (thunder, fire, earthquake, flood, salt, wind, insect, animals, etc...)
- c) Product is not disassembled, modified, or fixed. Components not disassembled or replaced.
- d) Warranty mark/stickers are not removed or broken.

Loss or damages resulted from conditions other than ones listed above are not covered under warranty.

2. Under warranty, SilverStone Technology's maximum liability is limited to the current market value for the product (depreciated value, excluding shipping, handling, and other fees). SilverStone Technology is not responsible for other damages or loss associated with the use of product.

3. Under warranty, SilverStone Technology is obligated to repair or replace its defective products. Under no circumstances will SilverStone Technology be liable for damages in connection with the sale, purchase, or use including but not limited to loss of data, loss of business, loss of profits, loss of use of the product or incidental or consequential damage whether or not foreseeable and whether or not based on breach of warranty, contract or negligence, even if SilverStone Technology has been advised of the possibility of such damages.

4. Warranty covers only the original purchaser through authorized SilverStone distributors and resellers and is not transferable to a second hand purchaser.

5. You must provide sales receipt or invoice with clear indication of purchase date to determine warranty eligibility.

6. If a problem develops during the warranty period, please contact your retailer/reseller/SilverStone authorized distributors or SilverStone <http://www.silverstonetek.com>.

Please note that: (i) You must provide proof of original purchase of the product by a dated itemized receipt; (ii) You shall bear the cost of shipping (or otherwise transporting) the product to SilverStone authorized distributors. SilverStone authorized distributors will bear the cost of shipping (or otherwise transporting) the product back to you after completing the warranty service; (iii) Before you send the product, you must be issued a Return Merchandise Authorization ("RMA") number from SilverStone. Updated warranty information will be posted on SilverStone's official website. Please visit <http://www.silverstonetek.com> for the latest updates.

Additional info & contacts

For North America (usasupport@silverstonetek.com)

SilverStone Technology in North America may repair or replace defective product with refurbished product that is not new but has been functionally tested. Replacement product will be warranted for remainder of the warranty period or thirty days, whichever is longer. All power supplies should be sent back to the place of purchase if it is within 30 days of purchase, after 30 days, customers need to initiate RMA procedure with SilverStone Technology in USA by first downloading the "USA RMA form for end-users" form from the below link and follow its instructions.

<http://silverstonetek.com/contactus.php>

For Australia only (support@silverstonetek.com)

Our goods come with guarantees that cannot be excluded under the Australian Consumer Law.

You are entitled to a replacement or refund for a major failure and for compensation for any other reasonably foreseeable loss or damage.

You are also entitled to have the goods repaired or replaced if the goods fail to be of acceptable quality and the failure does not amount to a major failure.

Please refer to above "Warranty terms & conditions" for further warranty details.

SilverStone Technology Co., Ltd. 12F No. 168 Jiankang Rd., Zhonghe Dist., New Taipei City 235 Taiwan R.O.C. + 886-2-8228-1238
(standard international call charges apply)

For Europe (support.eu@silverstonetek.de)

For all other regions (support@silverstonetek.com)

A large, faint, embossed-style watermark of the SilverStone logo is visible in the bottom right corner of the page. The logo consists of the words "SILVERSTONE" in a stylized, outlined font.

SilverStone Technology Co., Ltd.

www.silverstonetek.com

support@silverstonetek.com