



# PICO Pro INTERACTIVE INSTRUCTION MANUAL

You can navigate through chapters by clicking on the tabs here. 

Clicking on the PicoBrew logo will take you back to the Table of Contents. 

UNBOXING

SETUP

FIRST  
RINSE

LET'S  
BREW

AFTER  
BREWING

FERMENT  
YOUR BEER

DRY  
HOPPING

RACK &  
CARBONATE

SERVING

USAGE &  
CARE

SOUS VIDE

GLOSSARY



# **PICO** Pro **INSTRUCTION MANUAL**

**CRAFT  
BEER  
YOUR  
WAY.**

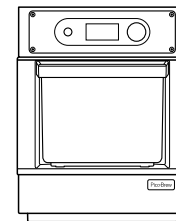

Produced by:  
PicoBrew Inc.  
2121 N 35th St.  
Seattle, WA 98103

[www.picobrew.com](http://www.picobrew.com)

© 2017 PicoBrew

All rights reserved. No part of this publication may be reproduced, stored in retrieval systems or transmitted in any form or by any means electronic or mechanical, including photocopying, record or any information storage and retrieval systems, without the written permission in writing from the copyright owners.

Printed and bound in Seattle, WA, USA

# IMPORTANT SAFETY INFORMATION

- Exercise common sense while operating the Pico.
- Always use the keg cozy to shield the hot metal of the keg.
- Close supervision is needed when used around children.
- Allow machine to fully cool before removing or replacing parts.
- Do not operate with a frayed cord or broken plug.
- Do not remove Step Filter from the Pico unless in pause mode or brew cycle is completed.
- The Step Filter and contents may be hot when removing from the machine.
- Do not immerse or soak the machine.
- Make sure all hoses are connected properly before starting a brewing, rinse, or cleaning cycle.
- To avoid risk of electrical shock hazard do not disassemble the Pico. There are no user serviceable parts inside.
- Various surfaces can get extremely hot during the brewing cycle, use caution when handling the keg, hoses and components.
- Do not remove the hose clamps, hot liquid spray may result.
- Do not remove the keg attachments while brewing.
- The product is intended for household use only.
- The appliance is not to be used, or played with, by children.
- The appliance is not to be used by persons with reduced physical, sensory or mental capabilities, or lack of experience and knowledge, unless they have been given supervision or instruction.
- If the power supply cord is damaged, it must be replaced by the manufacturer, its service agent or similarly qualified person in order to avoid a hazard.



- Per FCC 15.19(a)(3) and (a)(4) This device complies with Part 15 of the FCC Rules. Operation is subject to the following two conditions: (1) this device may not cause harmful interference, and (2) this device must accept any interference received, including interference that may cause undesired operation.
- Per FCC 15.21 Change or Modifications that are not expressly approved by the manufacturer could void the user's authority to operate the equipment.
- Per RSS-Gen, Section 8.4 This device complies with Industry Canada license-exempt RSS standard(s). Operation is subject to the following two conditions: (1) this device may not cause interference, and (2) this device must accept any interference, including interference that may cause undesired operation of the device.
- Par RSS-Gen, Section 8.4 Cet appareil est conforme à Industrie Canada exempts de licence standard(s) RSS. Le fonctionnement est soumis aux deux conditions suivantes: (1) ce dispositif ne peut pas provoquer d'interférences et (2) cet appareil doit accepter toute interférence, y compris les interférences qui peuvent causer un mauvais fonctionnement de l'appareil.

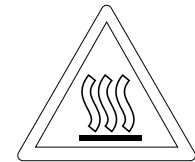



# **TABLE OF CONTENTS**

<b>INTRODUCTION</b>	<b>8</b>
<b>UNBOXING</b>	<b>10</b>
<b>SETUP</b>	<b>19</b>
<b>FIRST RINSE</b>	<b>27</b>
<b>LET'S BREW</b>	<b>37</b>
<b>AFTER BREWING</b>	<b>49</b>
<b>FERMENTATION</b>	<b>59</b>
<b>DRY HOPPING</b>	<b>75</b>
<b>RACK &amp; CARBONATE</b>	<b>81</b>
<b>SERVING</b>	<b>119</b>
<b>USAGE &amp; CARE</b>	<b>129</b>
<b>SOUS VIDE ADAPTER INSTRUCTIONS</b>	<b>171</b>
<b>GLOSSARY</b>	<b>187</b>

# WELCOME TO THE EASIEST COUNTERTOP BREWING APPLIANCE, EVER.

**SERIOUSLY.  
IT'S REALLY  
EASY TO USE.**



**THIS IS YOUR NEW  
BEST FRIEND.  
(IT MAKES BEER)**

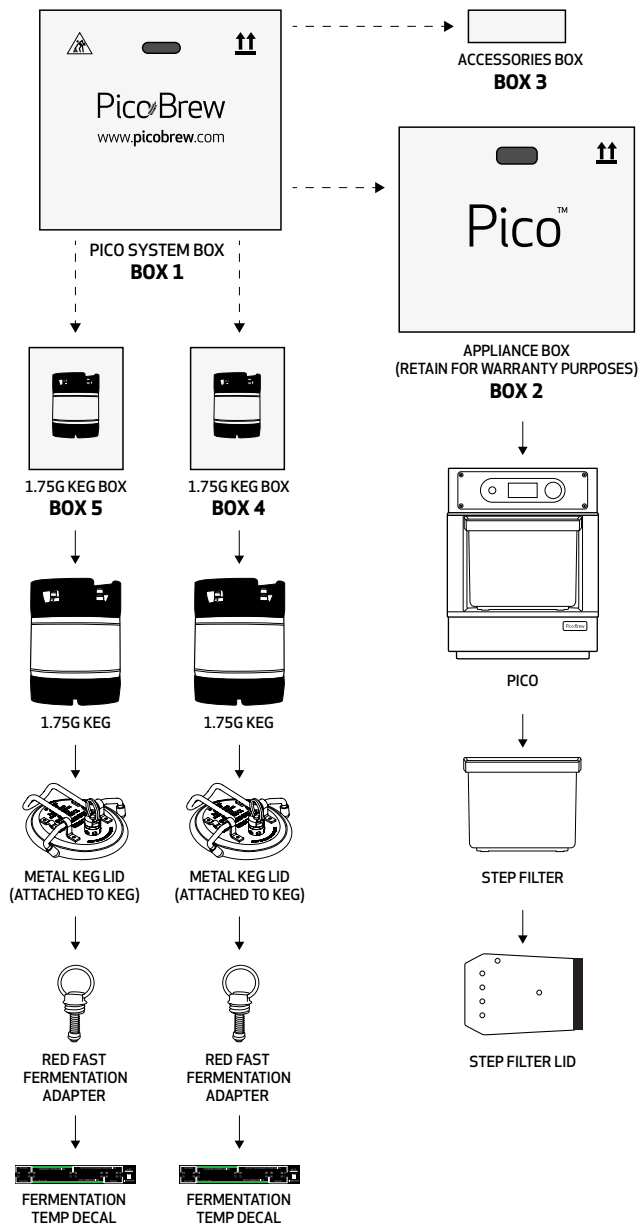

# PICO Pro UNBOXING GUIDE

## CONGRATULATIONS!

You are about to experience the joy of homebrewing using Pico, the most advanced homebrewing appliance in the world! We know you're eager to get started so let's make sure you have everything to brew and that each item arrived in perfect condition.

Inside your Pico Pro system box you will find 4 smaller boxes:

- Pico Appliance
- Accessories
- 2x 1.75G Keg (for brewing and serving)

**Note:** Some international units may have the Plug Adapter located inside the main shipper box instead of attached to the Pico unit itself. Keep Pico Appliance Box and inserts for warranty.

# BOX 3



## (A) TRANSFER TUBE

For transferring your beer from one 1.75G Keg to another.



## (B) KEG COZY

To keep your keg warm during brewing.

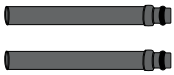

## (C) BLACK KEG WANDS (2)

Attaches to the Transfer Tube and Ball Lock Connector hoses for the Rinse cycle and cleaning.

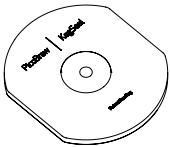

## (D) KEG SEAL

Used on Brewing Keg while brewing and during Standard Fermentation.



## (E) KEG SEAL STOPPER

Fits in Keg Seal vent hole, used only after brewing cycle is completed

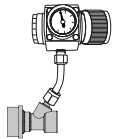

## (F) CO<sub>2</sub> REGULATOR

Ball Lock CO<sub>2</sub> regulator used for racking with CO<sub>2</sub>, forced carbonation, and dispensing.



## (G) 3/8 INCH THREADED ADAPTER

CO<sub>2</sub> regulator comes with 5/8" threaded adapter installed to use 74 gram CO<sub>2</sub> cartridges. Use optional 3/8" adapter for smaller 16 gram CO<sub>2</sub> cartridges.



## (H) DIP TUBE BRUSH

To clean your Brewing Keg Dip Tubes and Keg Posts.

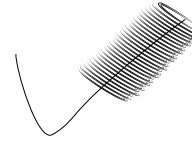

## (I) KEG BRUSH

To clean your Brewing Kegs.



## (J) HOPS PAK CRADLE

The cradle for your Hops Pak, used during the brewing cycle.



## (K) CLEANING TAB

Used when Deep Cleaning to thoroughly clean your Pico after every 3 brew sessions.

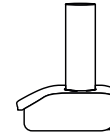

## (L) SOUS VIDE ADAPTER

Placed in Step Filter for sous vide.



## (M) PARTY TAP

For dispensing beer from the 1.75G Keg.

# BOX 4 AND BOX 5

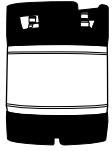

## (N) 1.75G BREWING KEG

For brewing, fermenting, and dispensing your beer.



## (O) METAL KEG LID

Attach to Brewing Keg. Gray Pressure Relief Valve will be attached to Metal Keg Lid upon arrival.



## (P) RED FAST FERMENTATION ADAPTER

For your Brewing Keg during Fast Fermentation.



## (Q) FERMENTATION TEMP DECAL

(1) Ale decal. Attach to Brewing Keg to monitor fermentation temperature. Can be re-used for 3 batches.



# DOUBLE CHECK YOUR SUPPLIES AND INVENTORY.

If any boxes look damaged or parts appear to be missing, please contact us immediately anytime via email at [support@picobrew.com](mailto:support@picobrew.com). We're here for you and want you to have a great Pico brewing experience!



## YOU WILL NEED:

- PicoPak (sold separately on BrewMarketplace)
- Wi-Fi connection (used in: **Setup, Let's Brew**)
- Access to an internet browser
- 3 gallons of distilled or reversed osmosis filtered water (used in: **First Rinse, Let's Brew**)
- Access to clean tap water
- Sterile water or vodka (used in: **Ferment**)
- 1.5 cups of 3% Hydrogen Peroxide or other food-grade sanitizer per manufacturer instruction (used in: **Rack & Carbonate**)
- Large bowl, bucket, or other waste container (used in: **After Brewing, Rack & Carbonate**)
- Fragrance-free powdered dishwashing detergent (used in: **Usage & Care**)
- 74g food-grade CO<sub>2</sub> cartridge required for forced carbonation (used in: **Rack & Carbonate**). Pressurized CO<sub>2</sub> cannot ship to some locations, register your Pico and check online to see if your location is supported.

# PICO SETUP

**ESTIMATED TIME:  
5 MINUTES**



**1** Remove the gray and white protective film and the red packing tape from Pico body and faceplate.

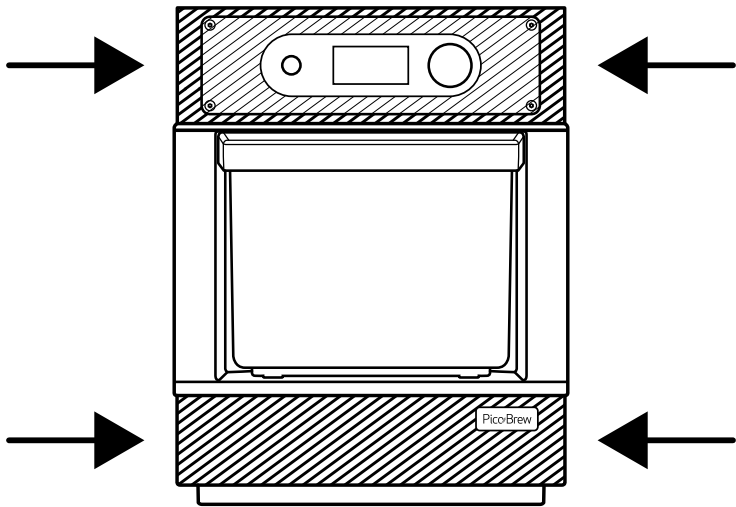

**2** Plug the power cord into a standard grounded household outlet. Press the power button to turn on your Pico.

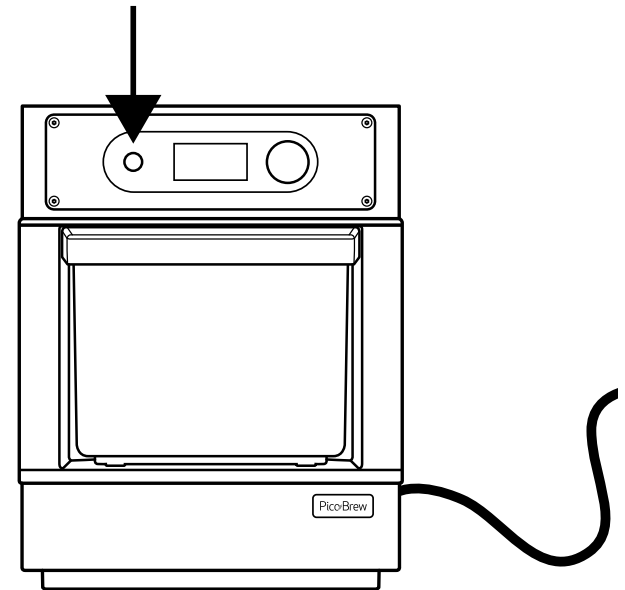

- 3** Connect to your home WiFi network by selecting it with the Control Knob, then enter your WiFi password. Once you enter your password, select the OK icon.

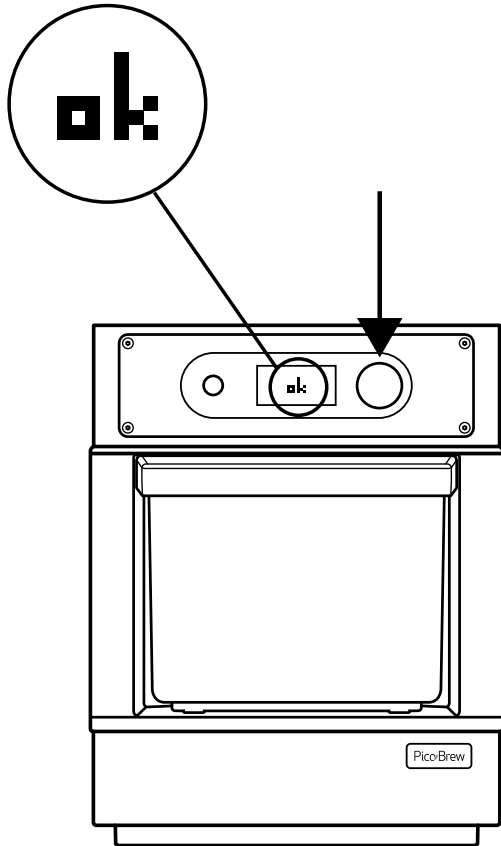

- 4** Once connected, note the registration code displayed on screen.

Go to: [www.picobrew.com/newpico](http://www.picobrew.com/newpico) Sign in to your account or create an account if you do not already have one, and enter the registration code displayed on your Pico.

**Add or update your address under account settings before registering your Pico.**

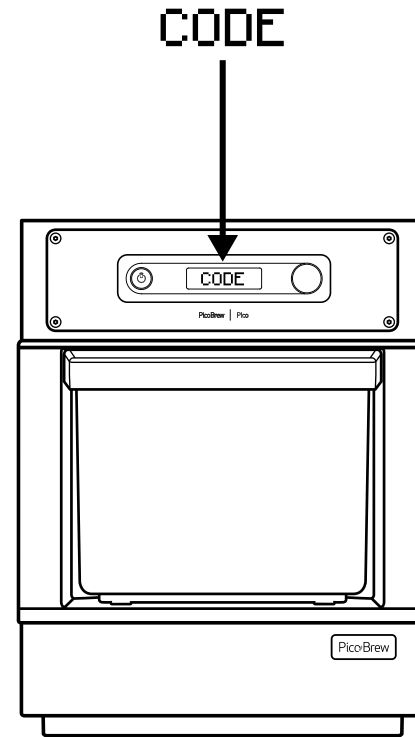



**NOW IT'S  
TIME TO  
GIVE YOUR  
PICO THE  
FIRST  
RINSE.**

**AFTER THAT  
YOU ARE  
READY TO  
BREW!**

**PROCEED TO NEXT SECTION: FIRST RINSE**



# FIRST RINSE

**ESTIMATED TIME:  
10 MINUTES**

## YOU WILL NEED:

- 0.5 gallon distilled water (or reverse osmosis)
- Keg Seal
- Brewing Keg
- Keg Wand

## IAN'S PRO TIP:

**Clean equipment is critical  
to crafting great beer.**

This first rinse ensures you  
start brewing with a sparkling  
clean Pico and accessories.

**1** After connecting up your Pico to the internet, wash the Brewing Keg, Keg Seal, Step Filter, and lid with hot, soapy water then rinse well. The Step Filter is located in the front of your Pico. To remove it lift it up and slide it out. After rinsing the Step Filter and lid slide them back into the Pico until the Step Filter clicks into place.

Set the Keg Seal Stopper aside, this will not be needed until after the brew session is finished.

**Note:** Make sure that when you remove the metal lid from your keg that the white O-ring is not left behind on the inside lip of the keg opening.

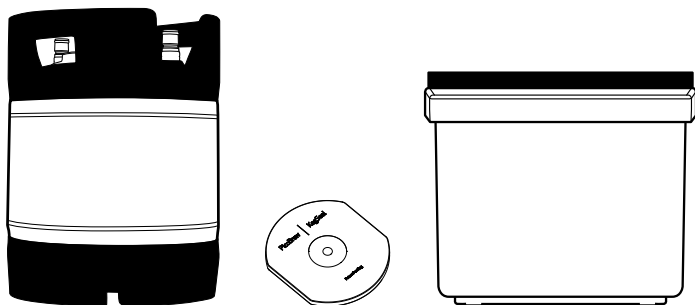

**2** Check that the Water Reservoir stopper is in place. This is located in the Water Reservoir in the center back area. Add 0.5 gallon (or 8 cups) of distilled water to the Water Reservoir. Add about 0.5 gallon of clean tap water to the Brewing Keg. Place black Keg Seal over the opening of Brewing Keg and press into the center of it until it pops into place.

**Note:** Do **NOT** use tap water inside the Pico Water Reservoir, only use distilled water.

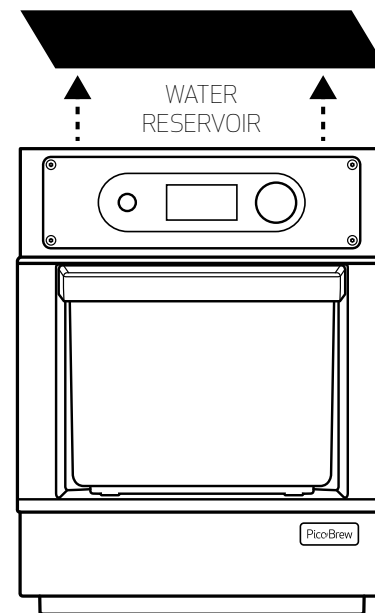

**3** Locate the post on the Brewing Keg marked "OUT" – locate the BLACK Ball Lock Connector on the end of the hose. Pull up on the outer plastic ring of the BLACK Ball Lock Connector, place the Connector on the OUT keg post, release outer plastic ring and press down firmly on Ball Lock Connector. Press down on the Connector until it audibly clicks into place. Repeat this procedure with the GRAY Ball Lock Connector on the keg post marked "IN".

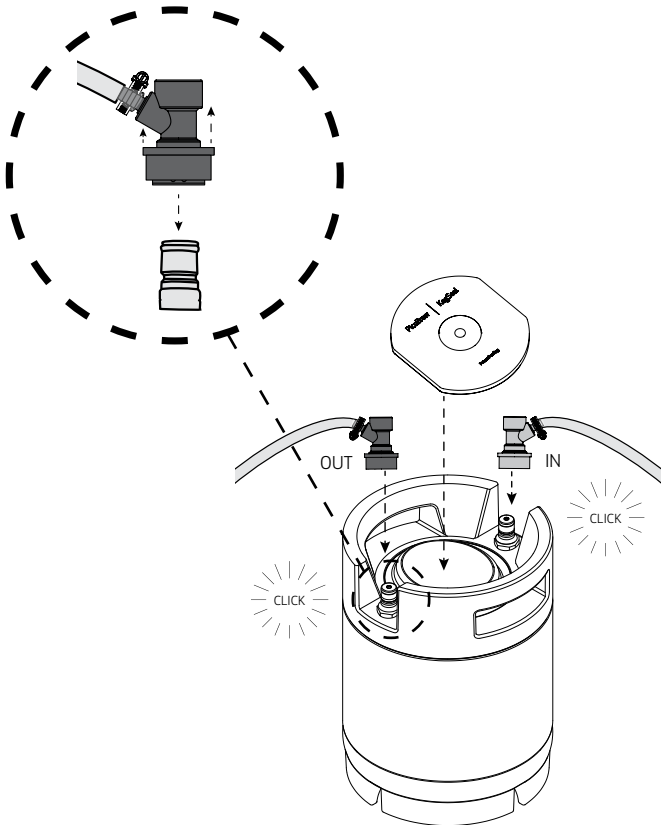

**4** Use the Control Knob to select Utilities. Press Control Knob to select **First Rinse**. After approximately 7 minutes the Pico First Rinse Cycle will complete.

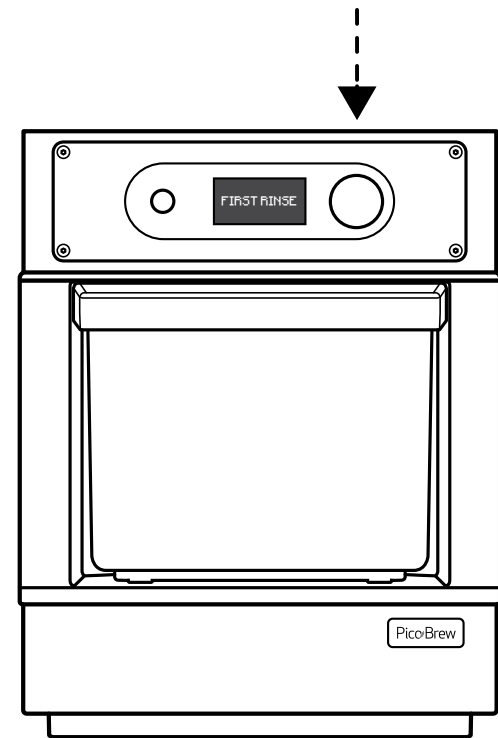

**5** The step filter will be mostly empty and there will be a little over 0.5 gallons in the Brewing Keg. The Water Reservoir will still contain almost all of the water you put in originally. Disconnect the Ball Lock Connectors from Brewing Keg by pulling up on the outer plastic rings and lifting up off of Brewing Keg posts.

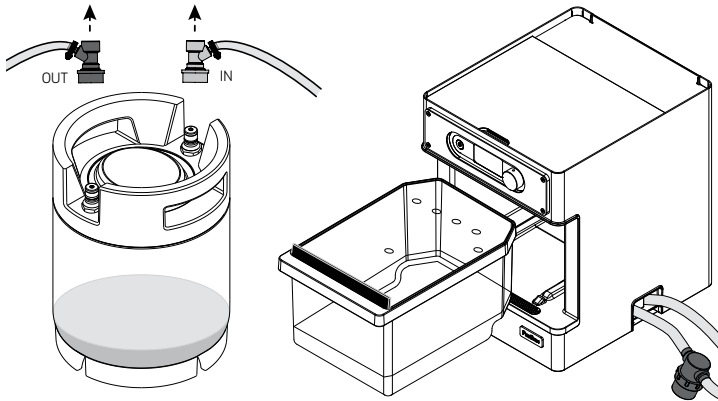

**6** Connect a clean Keg Wand to the BLACK Ball Lock Connector by pulling up on the outer ring of the Connector and inserting Keg Wand, release outer ring and make sure it is securely connected to Connector. Press Control Knob to begin pumping water out of Water Reservoir and into the Step Filter. Follow on-screen instructions and press Control Knob between steps. Press Control Knob when the Water Reservoir is empty.

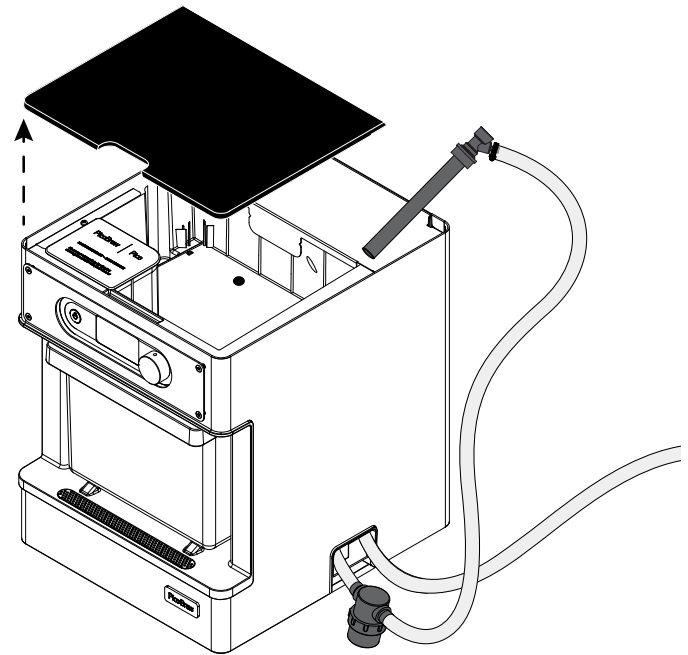

**7** The Inline Filter is a black plastic cylinder in the middle of the Black Ball Lock Connector hose . Unscrew and remove the Inline Filter cap. Remove the blue Inline Filter wire mesh insert and rinse it thoroughly using tap water. Place the Inline Filter mesh insert back into the Inline Filter and screw the filter cap back on, finger tight. This step should be performed after every Rinse Cycle to ensure cleanliness and longevity of your Pico.

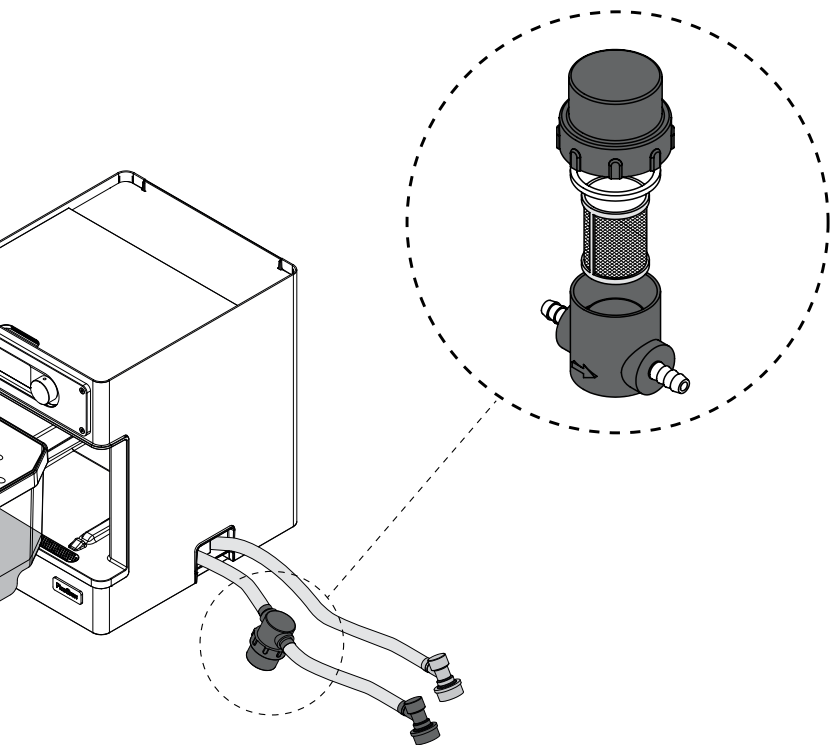

**8** Empty your Brewing Keg and Step Filter. Rinse Brewing Keg, Step Filter, Keg Seal, and Keg Wand.

**You are now ready to begin your first Pico brew session!**

**If you experience any problems during your First Rinse, brewing session, or any other step of the process please visit [www.picobrew.com/Help](http://www.picobrew.com/Help) or contact us immediately at [info@picobrew.com](mailto:info@picobrew.com).**





# LET'S BREW

**ESTIMATED TIME:  
HANDS ON 10 MINUTES  
(TOTAL TIME: 2.5 HOURS)**

## **YOU WILL NEED:**

- PicoPak
- 2.5 gallons distilled water (or reverse osmosis)
- Hops Cradle
- Brewing Keg
- Black Keg Seal
- Keg Cozy

- 1** Remove the vacuum-sealed wrapping and insert the Pico Hops Pak all the way into the metal Hops Pak Cradle. The fingers of the Cradle fit in the grooves of the Hops Pak.

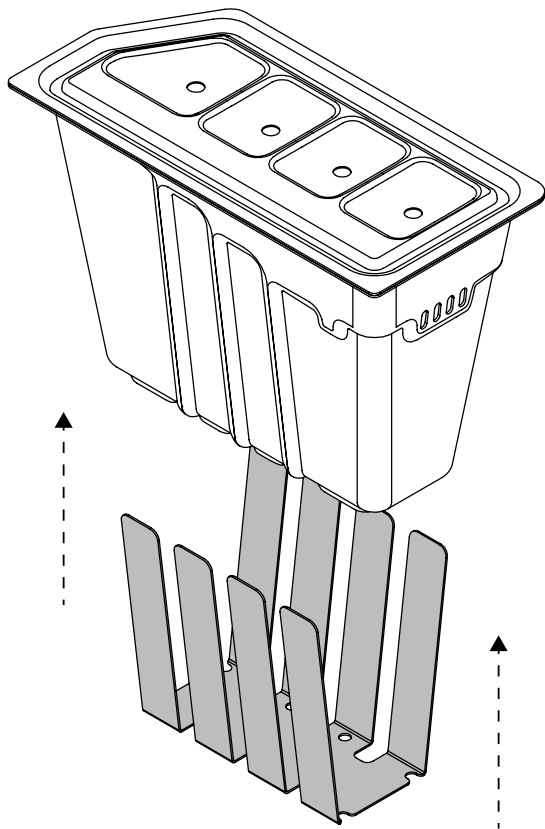

- 2** Unwrap and set the Grain Pak in the front of the Pico Step Filter, with the beer design facing the front. Place Hops Pak and Cradle in the rear of the Step Filter, pushed all the way to the left.

**Note:** It's normal for some powder from the Grain Pak to have shaken loose during shipping, please discard this with the packaging.

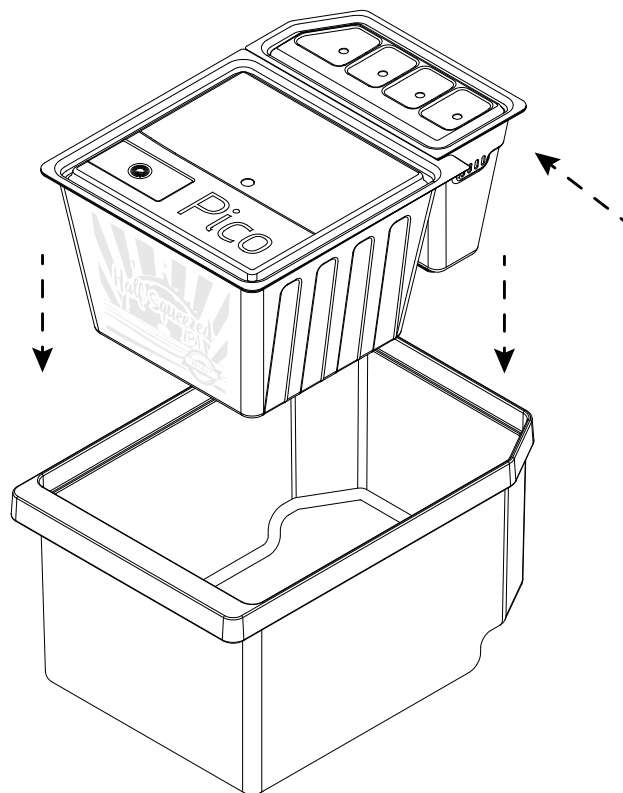

**3** Cover the Step Filter with the lid, with the black Steam Deflector in the front and facing up. When putting the Step Filter lid on make sure all lid holes match up to all Hops Pak holes.

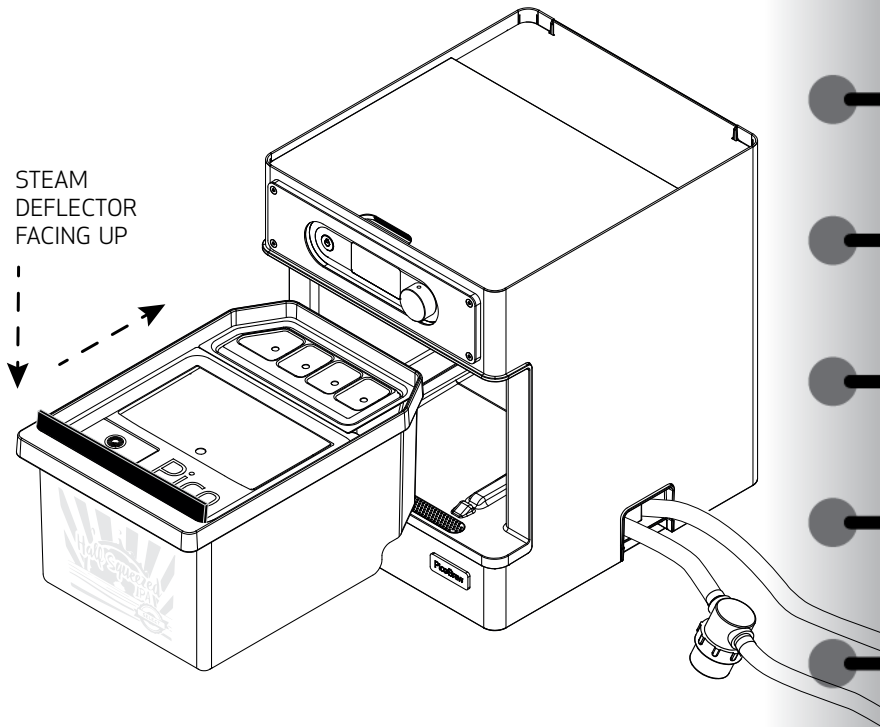

**4** Open the top of the clean Brewing Keg and add 1 gallon plus 6 cups, or 11.4 lbs of distilled or reverse osmosis water. Set the rubber Keg Seal on the keg opening and press seal into the center of the keg until it pops into place, sealing the keg.

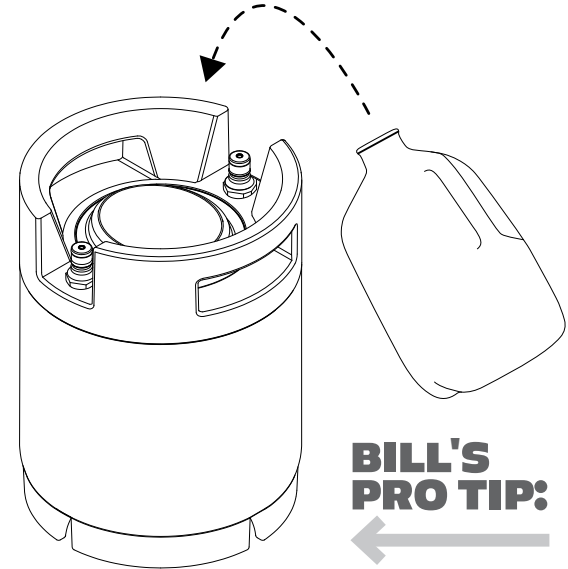

**BILL'S PRO TIP:**

**Save the water jug!**  
It's opening is the perfect size for Ball Lock Connectors and makes a great waste container for After Brewing.

**5** Slide the Keg Cozy over the Brewing Keg. Attach the Pico hose with the BLACK Ball Lock Connector to the post on the Brewing Keg marked "OUT". Then attach the GRAY Ball Lock Connector to the "IN" keg post.

**Note:** Do not use the Metal Keg Lid while brewing, only use the rubber Keg Seal. Make sure the red stopper is not inserted in the Keg Seal center hole while brewing.

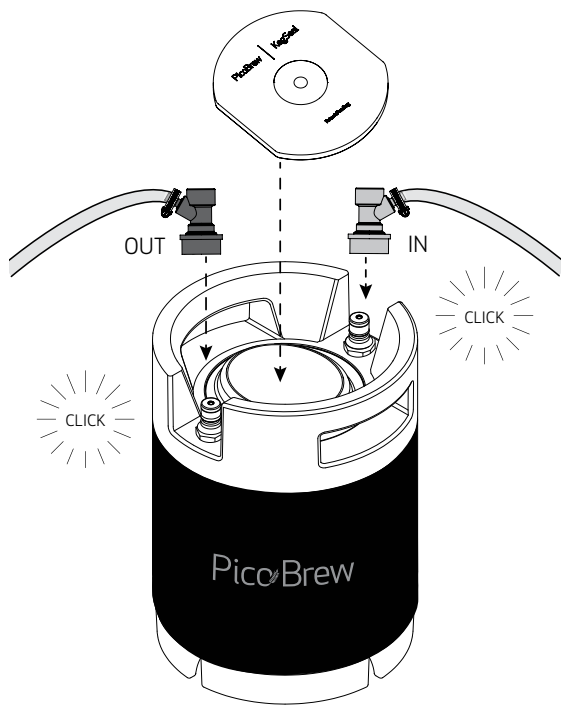

**6** Remove the Water Reservoir lid from the top of the Pico. Look inside and check to make sure the black rubber Drain Plug is secured inside the reservoir drain located in the center of the back of the reservoir. Fill the reservoir with approximately one gallon of distilled water. Replace the Water Reservoir lid.

**Note:** If using tap water inside the Pico Water Reservoir, remember to descale every 20 brews. (**Usage & Care:** Pico Descal). Tap, distilled, or reverse osmosis water is fine inside the Brew Keg. Using heavily chlorinated water can cause off flavors in finished product.

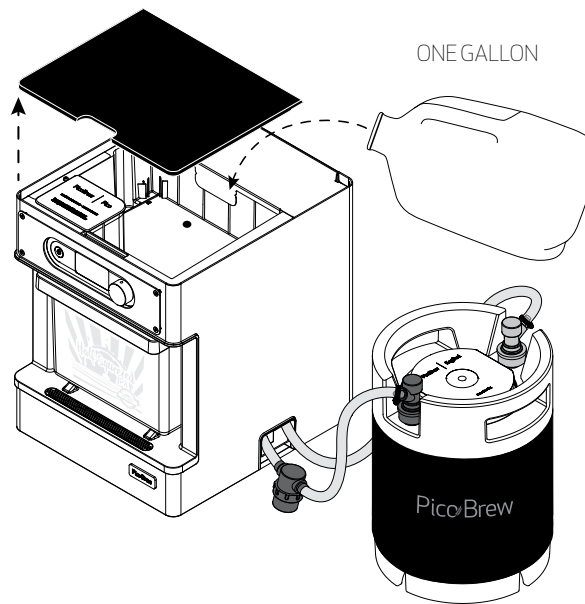

# 7

Press the Power Button on the front of the Pico. The display will illuminate. Select Brew PicoPak and press the Control Knob. The Pico will automatically detect and display the PicoPak.

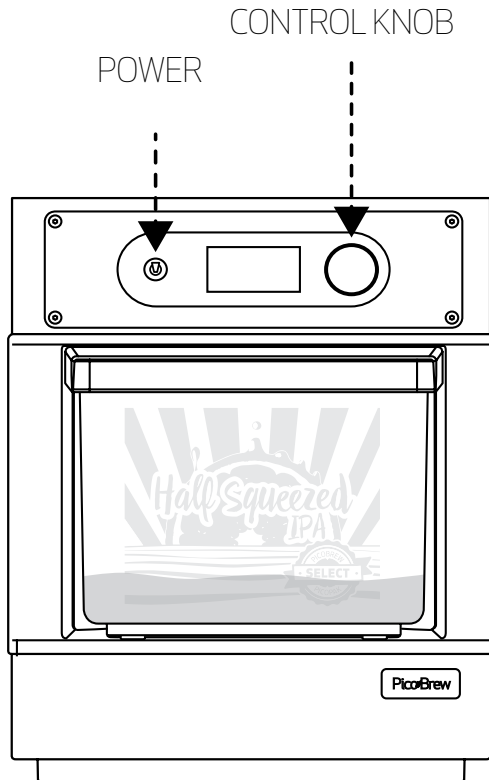

# 8

You can optionally change a beer's alcohol percentage and bitterness from the PicoPak defaults. To do so, turn Control Knob to the right when screen says "Start Brewing". This will give you the ability to adjust the alcohol and bitterness. Once finished, you can select Start Brewing by pressing the Control Knob and your brew session will begin.

**Note:** This option is only available for select PicoPaks at this time.



**9** Pico will begin brewing and complete in approximately 2-3 hours, depending on the beer recipe and any adjustments you might have made. You do not need to monitor the Pico during the brew session.

**Notes:**

- You can track the progress by signing in at [www.PicoBrew.com](http://www.PicoBrew.com) and clicking on **BrewHouse**.
- During brew session some foam on the Keg Seal is normal, particularly during a drain cycle. You can wipe it off with a clean damp paper towel.
- It is normal for only a small amount of liquid to show in the bottom of the Step Filter during brewing.
- Pico heats the water using steam, and occasional hissing or growling noises are normal. Don't worry, Pico is not upset, only heating!

**PROCEED TO NEXT SECTION:  
AFTER BREWING**

If you run into any issues while brewing, contact [support@picobrew.com](mailto:support@picobrew.com).



**CONGRATS!  
YOU CAN  
NOW  
SIT BACK,  
RELAX  
AND  
ENJOY  
YOUR  
FIRST  
BREW  
CYCLE.**

**GOOD JOB.**



# AFTER BREWING

**ESTIMATED TIME:  
HANDS ON 9 MINUTES  
(TOTAL TIME: 24 HRS)**

## **YOU WILL NEED:**

- Keg Seal Stopper
- Keg Wands
- Waste container  
(needs to hold approximately one gallon of liquid)

**1** After brewing finishes, disconnect both of the Ball Lock Connectors from the Brewing Keg by pulling up on the outer plastic ring of each Ball Lock Connector and then pulling the Connector off of the post.

Wipe away any foam off the Keg Seal using a damp paper towel. Insert the Keg Seal Stopper into the center hole of the Black Keg Seal so that the keg is airtight.

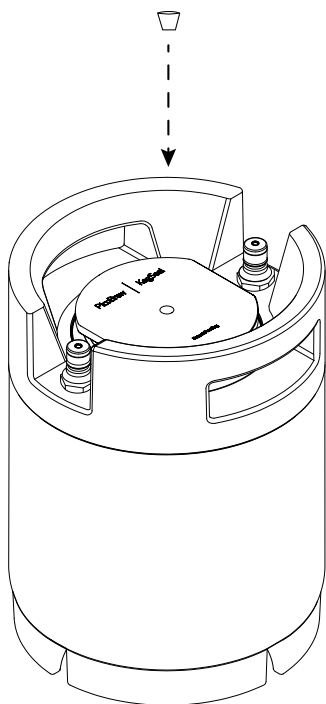

**2** Set the Brewing Keg aside to cool overnight in room temperature and remove the Keg Cozy from the Brewing Keg. It is normal for the Keg Seal to suction slightly into the Brewing Keg as it cools, don't worry it will not be pulled all the way inside. You will need to pitch the yeast within 24 hours after brew session is completed.

Now remove the Step Filter from the Pico and dump the biodegradable PicoPak into a compost bin. **Remember to keep the Metal Hops Cradle and set it aside for future brewing sessions.**

**Note:** The Brewing Keg will be very HOT so please be careful and only touch the keg's black rubber handles.

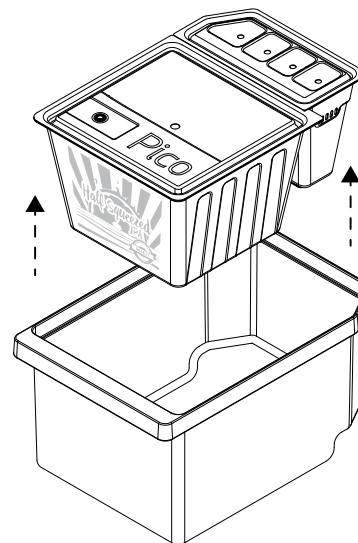

## ANNIE'S PRO TIP:

### Be careful!

The Hops Cradle is hot directly after brewing. Give it chance to cool before you touch it.

PicoPaks fit perfectly into an 8"x8" square baking dish. Flip the Step Filter upside down so the PicoPak goes into dish upside down, use tongs to take the metal Hops Pak Cradle out to reuse for future brewing sessions. Use the dish to carry the PicoPak to your compost bin!

**3** Rinse the Step Filter and lid with clean tap water. Fill the clean Step Filter with approximately 1 inch of tap water. Insert the Step Filter and lid back into the Pico until it clicks.

For each Ball Lock Connector, pull up on the outer ring of the Connector and insert a Keg Wand. Release the ring and make sure it is properly connected to the Keg Wand.

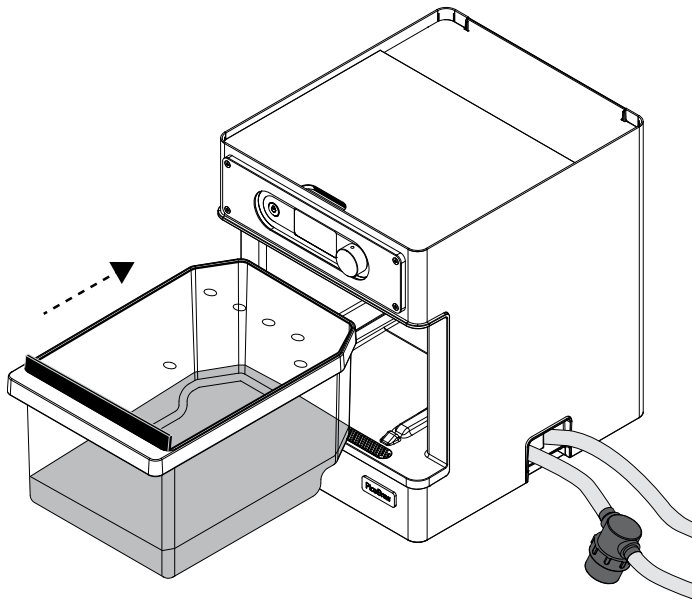

**TAP WATER**

**4** Direct the end of the GRAY Ball Lock Connector ("IN") Keg Wand into a waste container or directly into a sink nearby. Press the Control Knob to start Rinse Cycle. Pico will clear the drain line into the waste container, then prompt you to empty the reservoir.

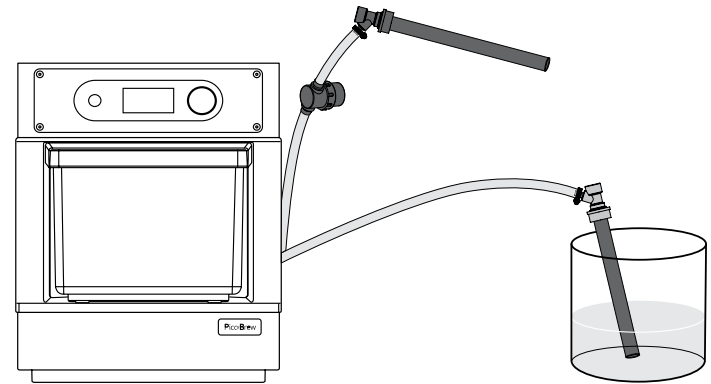

**BILL'S PRO TIP:**

Make sure you use a big enough waste water container! The gallon water jug you used to fill the machine is perfect for this use.

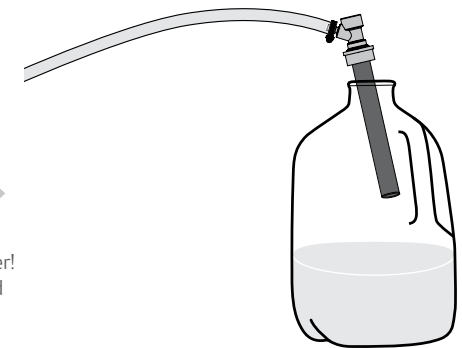

**5** Insert the end of the BLACK Ball Lock Connector ("OUT") into the Water Reservoir. Press the Control Knob to run the pump until the Reservoir has drained. The water will be deposited into the Step Filter. To stop the pump press the Control Knob when the Reservoir is empty. Now press the power button on the Pico to turn it off.

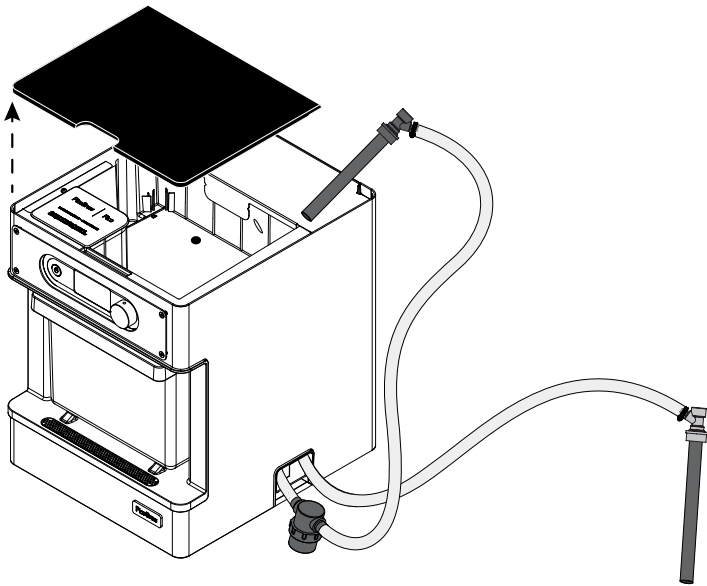

**6** Unscrew and remove the Inline Filter cap. Remove the blue filter insert and rinse it thoroughly using tap water. Place it back in the Inline Filter and screw the filter cap back on, finger tight.

**JACK'S PRO TIP:**

Cleaning the Inline Filter after every brew session is very important and will lengthen the life of your Pico!

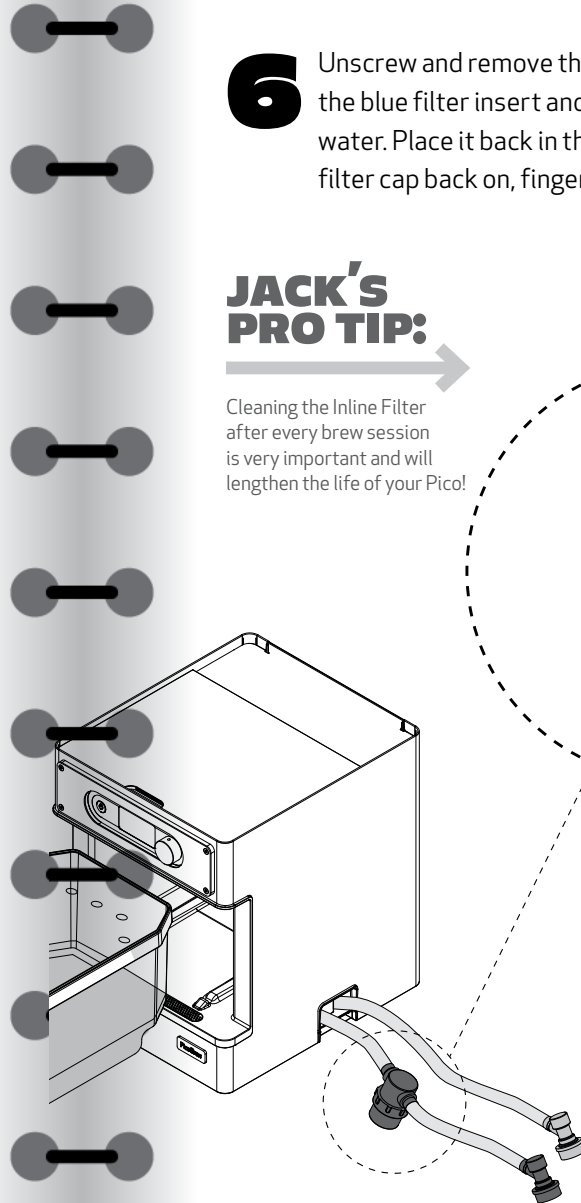
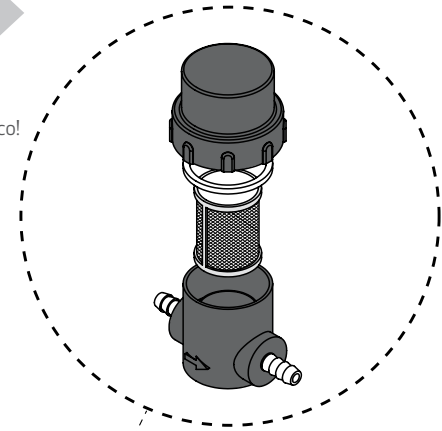

**7** Remove the Keg Wands from the Ball Lock Connectors by pulling up on the outer plastic rings. Remove the Step Filter and lid from the Pico and rinse thoroughly with tap water, they are both dishwasher safe.

**Note:** Do NOT use the Heat Dry or Sanitize option on your dishwasher. Condensation or Air Dry options are fine to use.

**PROCEED TO NEXT SECTION:  
FERMENTATION**



**AWESOME!  
IT WOULD  
APPEAR  
THAT  
YOUR PICO  
IS CLEAN  
AS A  
WHISTLE.**

**A CLEAN MACHINE  
MEANS BETTER  
BREWING.**



# FERMENT YOUR BEER

**ESTIMATED TIME:  
6 MINUTES**

**YOU WILL NEED:**

- Your keg of brewed wort, cooled to room temperature
- Fermentation Temperature Decal
- Yeast Packet
- Sanitized, clean whisk

**FOR FAST FERMENTATION:**

- Metal Keg Lid
- Red Fast Fermentation Adapter

**FOR STANDARD FERMENTATION  
(OPTIONAL):**

- Black Keg Seal
- Air Lock (not included with accessories)
- Sterile water or vodka

**1** After brewing, allow the Brewing Keg to cool to room temperature, this may take up to 24 hours depending on ambient temperature.

Stick the Fermentation Temperature Decal on the outside of the cooled Brewing Keg.

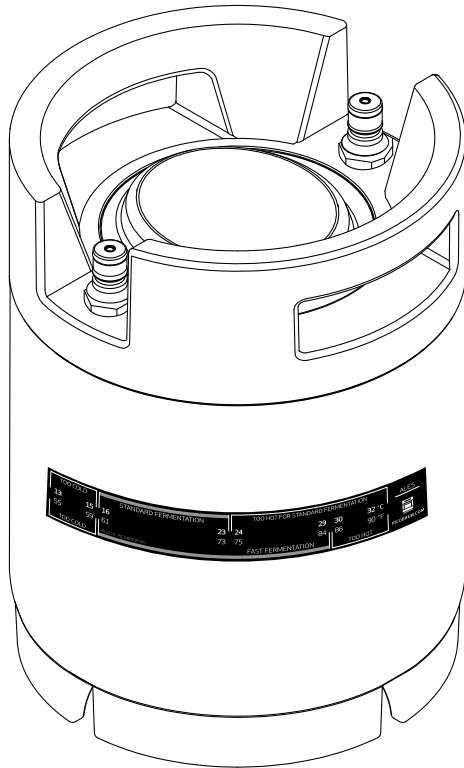

**2** Remove the black Keg Seal and Stopper from the Brewing Keg. Use a clean, sanitized whisk to stir the wort (unfermented beer) vigorously for about 3 minutes.

Open the provided Yeast Packet and slowly sprinkle all of the contents into the Brewing Keg. You do not need to stir the yeast into the wort.

**Note:** Yeast should be pitched within 24 hours of brewing session.

### JACK'S PRO TIP:



Off-flavors can result from a harsh, low-oxygen environment for your yeast during primary fermentation. Your wort needs proper levels of dissolved oxygen for a healthy fermentation, so make sure to stir your wort before pitching yeast! Alternately, you can aerate your wort using a sanitized electric hand-held whisk on high for 1 minute.

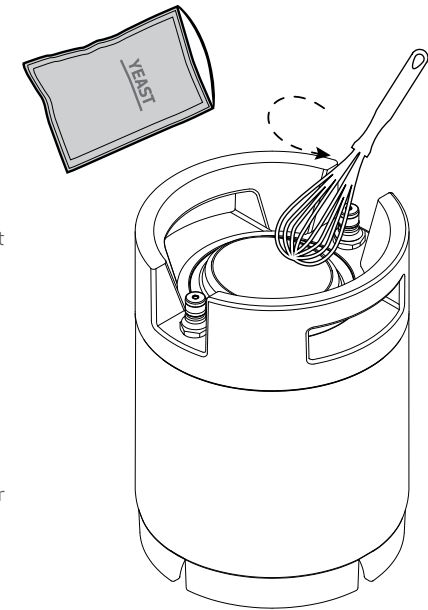

### 3 REFER TO THE FERMENTATION TEMPERATURE DECAL:

#### FOR FAST FERMENTATION

(See steps 4-7) Confirm that the Red Fast Fermentation Adapter is installed in the Metal Keg Lid. The wort can properly ferment at any temperature in the Fast Fermentation range indicated on the decal, however you only speed up fermentation by keeping the keg temperature at the higher end of the range, above standard fermentation temperatures.

#### FOR STANDARD FERMENTATION:

(See steps 8-11) Confirm that a Keg Seal and Air Lock are installed on the Brewing Keg. The wort can properly ferment at any temperature in the Standard Fermentation range indicated on the Fermentation Temperature Decal.

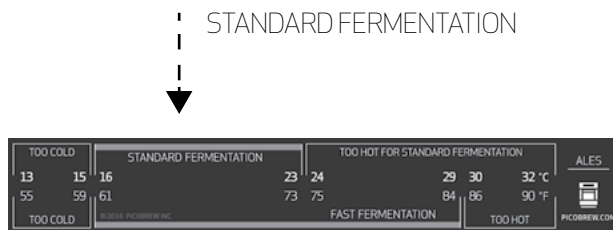

# IF YOU PREFER FASTER FERMENTATION FOLLOW THESE SIMPLE STEPS

## YOU NEED YOUR BEER QUICKLY? WHO DOESN'T?

**4** Locate the Metal Keg Lid and remove the **GRAY** Pressure Release Valve from the lid by unscrewing it counter clockwise.

Locate the **RED** Fast Fermentation adapter (it looks like the gray one you just removed) and screw it clockwise all the way into the pressure release hole of the Metal Keg Lid.

LOCKING CLAMP

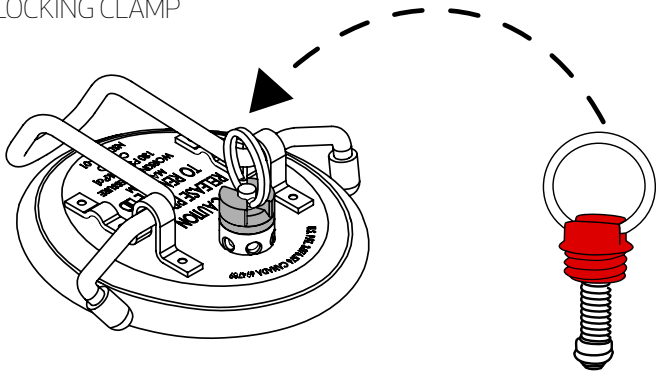

ONLY USE RED FAST  
FERMENTATION  
ADAPTER

**5** Insert the Metal Keg Lid into the Brewing Keg, confirm it is seated correctly and push down on the locking clamp.

Let the Brewing Keg stand for 3-5 minutes and then shake it vigorously. Make sure no wort leaks from the Keg Lid. If you see a leak, unlock the Metal Keg Lid and ensure it is seated correctly before locking again.

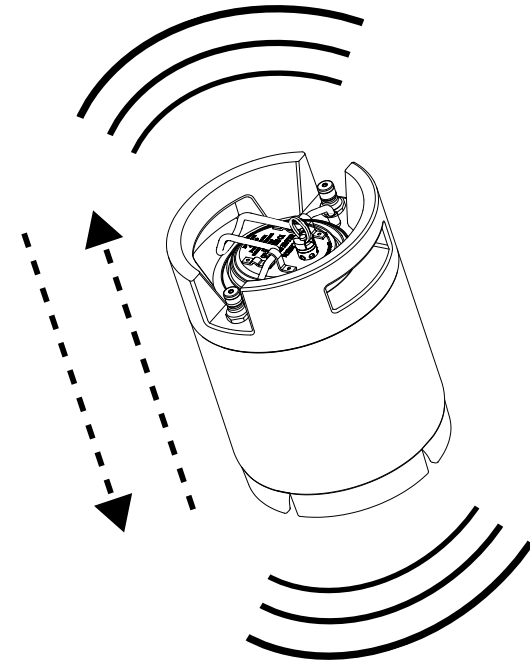

**6** Carefully place your Brewing Keg in a temperature-controlled area where it will remain at the “Fast Fermentation” range indicated on the Temperature Decal on the Brewing Keg. It is normal for the Fast Fermentation Adapter in the lid to occasionally release CO<sub>2</sub> as it builds up in the keg due to fermentation. This occasional release may result in some bubbling of krausen, which is the slightly sticky fermentation foam, onto the Metal Keg Lid. If any krausen bubbles out just wipe it off with a damp paper towel.

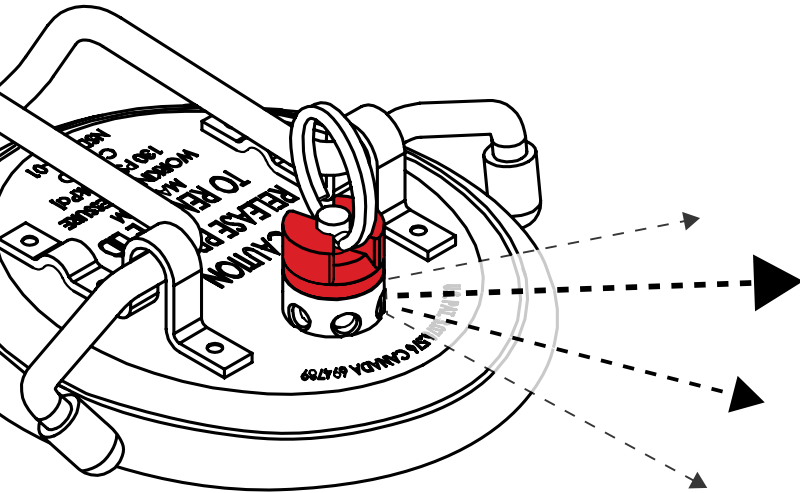

**7** Read the temperature indicated by your Fermentation Temperature Decal on the side of the Brewing Keg and consult the tables below to see how long Fast Fermentation should take to complete for your beer.

### 6.5% ABV AND BELOW

KEG TEMPERATURE (F)	DAYS TO FAST FERMENT
75° - 84°	4 - 5
70° - 74°	5 - 6
65° - 69°	6 - 7

### 6.5% - 8.5% ABV

KEG TEMPERATURE (F)	DAYS TO FAST FERMENT
75° - 84°	6 - 8
70° - 74°	7 - 9
65° - 69°	9 - 12

### 8.5% ABV AND ABOVE

KEG TEMPERATURE (F)	DAYS TO FAST FERMENT
75° - 84°	9 - 10
70° - 74°	10 - 12
65° - 69°	12 - 14

**8** After your beer is done fermenting, move your Brewing Keg into the refrigerator. This will cold crash the yeast and also help with racking the beer. Allow the beer to sit for 1-3 days at colder temperatures before racking your beer.



**IF  
STANDARD  
FERMENTATION  
IS MORE  
YOUR THING  
USE THE  
FOLLOWING  
STEPS.**

**THE CHILL OUT ROUTE.**

**9** Insert the Keg Seal into the top of the Brewing Keg. Insert the Airlock into the Keg Seal center hole.

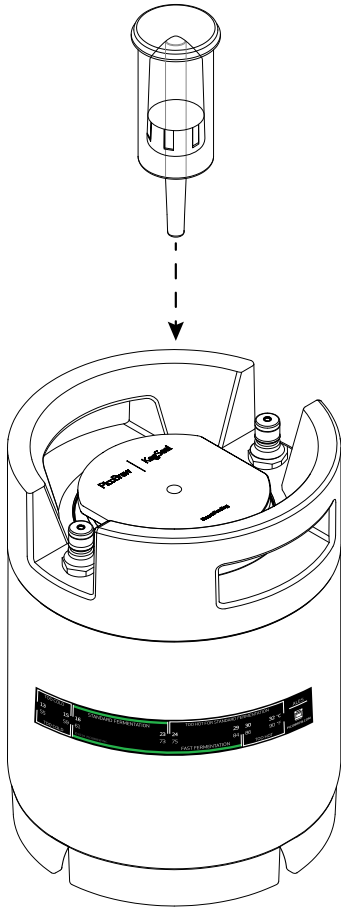

**WILL'S  
PRO TIP:**



Don't force the Airlock too far into the Keg Seal. Insert the Airlock up to 1/2 an inch or until it fits tightly.

**10** Fill your Airlock with sterile water (or vodka) to fill line. The Airlock keeps the Brewing Keg properly sealed against any wild yeast or bacteria, while still allowing CO<sub>2</sub> to release as the beer ferments.

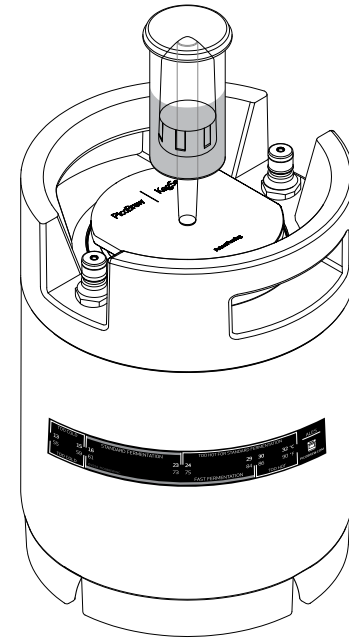

# 11

Place your Brewing Keg in a temperature-controlled area where it will remain at the "Standard Fermentation Range Temperature" indicated on the Temperature Decal on the Brewing Keg. Fermentation can take anywhere from a week to several weeks depending on the beer recipe.

# 12

As your beer ferments, CO<sub>2</sub> is released through the Airlock. The bubbling will be vigorous the first couple of days of fermentation then slow down. When the bubbling slows significantly or completely stops that is when fermentation has neared completion, (on average 10 days.)

## KEVIN'S PRO TIP:



The day before you transfer your beer, replace your Keg Seal and Airlock with the sanitized Metal Keg Lid and move your keg into the refrigerator. This will cold crash the yeast and will also help in racking the beer.





# DRY HOPPING

**ESTIMATED TIME:  
1 MINUTE**

**THIS STEP IS OPTIONAL.  
CERTAIN BEERS WILL COME  
WITH A DRY HOP SACHET.  
YOU WILL NEED:**

- Your keg of fermenting beer
- Dry Hop Sachet

# 13

If your PicoPak contains a Dry Hop Sachet (packaged inside the same box with the Yeast Packet) there is an extra step in order to dry hop your beer to add maximum hop flavor and aroma.

Store the Dry Hop Sachet packet in your refrigerator along with the yeast when you receive your PicoPak.

# 14

After 3 days, remove the Metal Keg Lid or Black Keg Seal from the Brewing Keg. Remove the Dry Hop Sachet from your refrigerator and open the clear vacuum-sealed bag, do NOT open the paper sachet bags. Place the paper Dry Hop Sachet bags into the Brewing Keg with your beer. The paper sachets are designed to work inside your Brewing Keg while preventing clogging during the racking process.

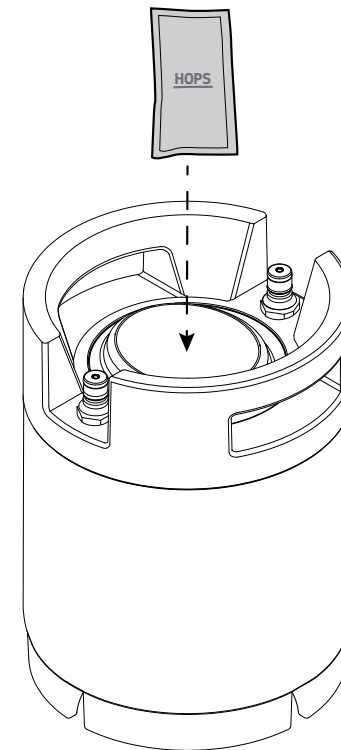

# 15

Replace and clamp the Metal Keg Lid or Black Keg Seal on to the Brewing Keg and confirm it is seated correctly on Brewing Keg.

Allow your beer to continue to ferment with the Dry Hops for a minimum of 4 more days, longer if fermentation is not yet complete.

**PROCEED TO NEXT SECTION:  
RACK & CARBONATE YOUR BEER**





# RACK & CARBONATE YOUR BEER

**ESTIMATED TIME:  
15 MINUTES**

**YOU WILL NEED:**

- Your keg of completed fermented beer at room temperature or chilled
- 1.5 cups of 3% Hydrogen Peroxide (or food grade sanitizer prepared according to manufacturer's instructions) and 1.5 cups of clean water
- Large Bowl
- Waste container
- Empty Brewing Keg
- Transfer Tube
- Keg Wands
- Gray Pressure Relief Valve

---

**FOR RACKING WITH CO<sub>2</sub> AND FORCED CARBONATION:**

- CO<sub>2</sub> Regulator and Cartridge

**FOR KEG CONDITIONING:**

- Carbonation Sugar Packet

**1** Sanitize the empty Brewing Keg by pouring 1.5 cups of clean tapwater and 1.5 cups of 3% hydrogen peroxide. Insert the Metal Keg Lid with the Gray Pressure Relief Valve into the Brewing Keg, confirm it is seated correctly and push down on the locking clamp. Shake the keg and let it sit for 10 minutes. Empty the keg contents into a large bowl and rinse the keg with clean water.

**Note:** StarSan (available on [www.picobrew.com/BrewGear](http://www.picobrew.com/BrewGear)) is an effective alternative to hydrogen peroxide. Follow all manufacturer's instructions. Use caution while using StarSan and do not soak plastic components in solution for more than 5 minutes. Do not rinse after using StarSan. Don't fear the foam!

**2** Attach the keg wands to both ball fittings of the Transfer Tube. Soak the Transfer Tube for 5 minutes in the large bowl of sanitizing solution you set aside earlier. Remove the Keg Wands from the Transfer Tube and rinse with clean water.

**PROCEED TO NEXT SECTION:  
RACK THE BEER**





# RACK & CARBONATE YOUR BEER

## STEP 1: RACK THE BEER (WITH CO<sub>2</sub> REGULATOR)

**\*SKIP TO PAGE 91, STEPS 5-8 IF RACKING WITH PICO**

# 1

Turn the CO<sub>2</sub> Regulator knob counter clockwise all the way to close it. Quickly screw a new CO<sub>2</sub> cartridge clockwise into the Regulator. The Cartridge will pierce through metal and you might hear a brief air sound. Continue to screw the Cartridge into the Regulator until you can no longer turn it. Insert the Metal Keg Lid with the Red Fast Fermentation adapter onto the Brewing Keg with your beer if not already on. Make sure the Metal Keg Lid with the Gray Pressure Relief Valve is inserted onto the Brewing Keg that you will racking to. Connect your CO<sub>2</sub> Regulator to the IN post of the Brewing Keg you will be racking from.

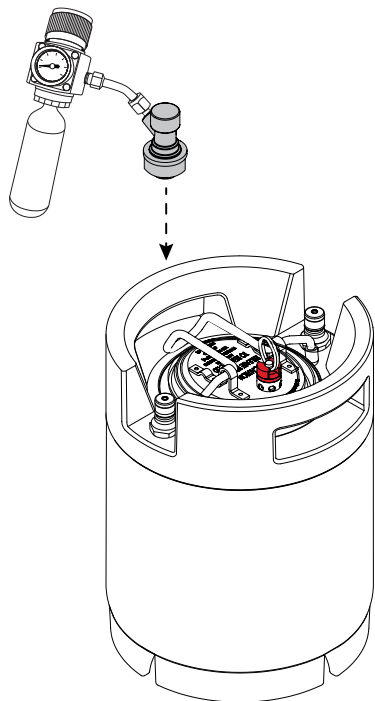

PicoBrew

# 2

Attach the Transfer Tube to the two Brewing Kegs by connecting the ball locks to the OUT posts of each keg.

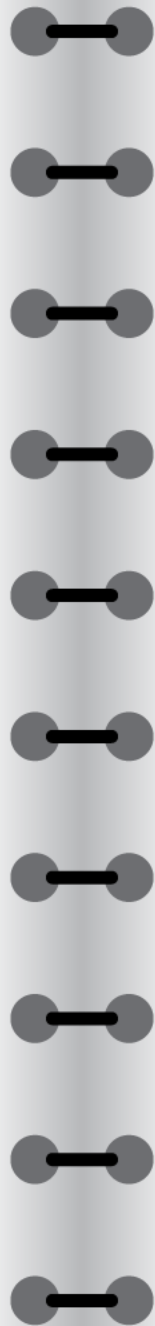
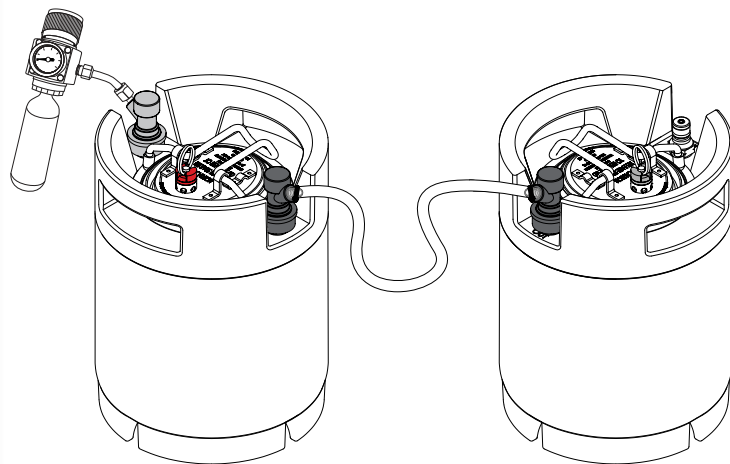

**3** Pull up the Gray Pressure Relief Valve on the Brewing Keg that you will be racking to and turn the ring in any direction 90 degrees to relieve built up pressure and restore a steady flow of beer. Slowly dial the Regulator clockwise to open the Regulator until it reaches 5 PSI to transfer your beer.

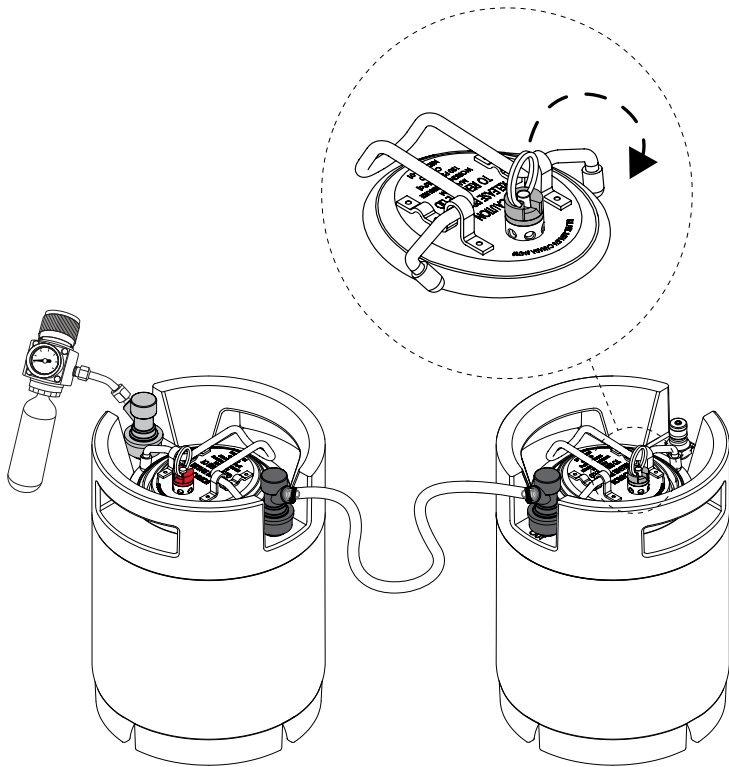

**4** When air begins to enter the Transfer Tube, close the CO<sub>2</sub> regulator and remove the Transfer Tube from both kegs. Turn the Gray Pressure Relief Valve back 90 degrees to close.

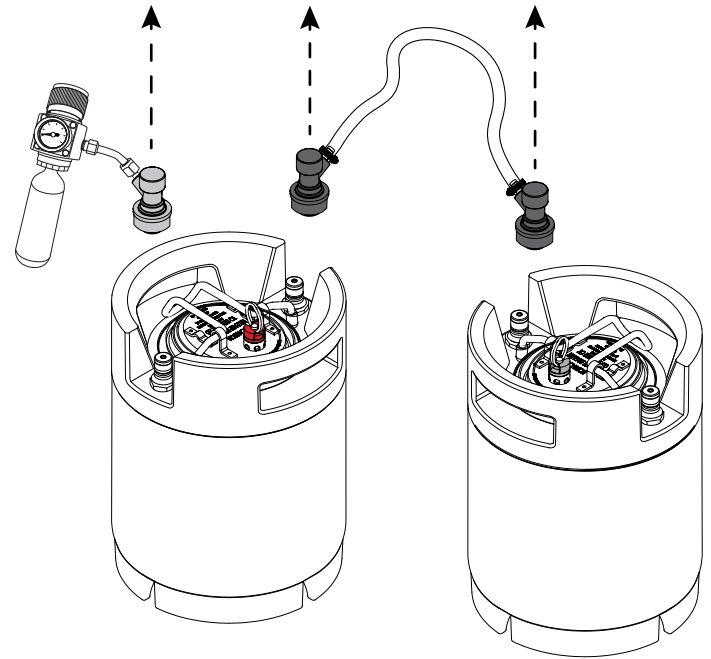

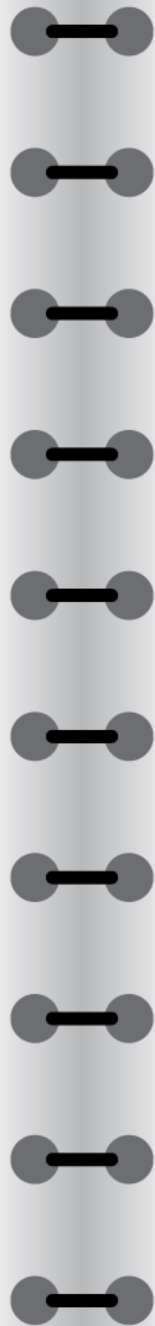

# RACK & CARBONATE YOUR BEER

## STEP 2: RACK YOUR BEER WITH PICO

**5** Remove Brewing Keg from your refrigerator. From the Pico main menu select **Utilities** then select **Rack Beer** on the Pico display. This will provide step-by-step instructions on screen.

Press the Control Knob between each step.

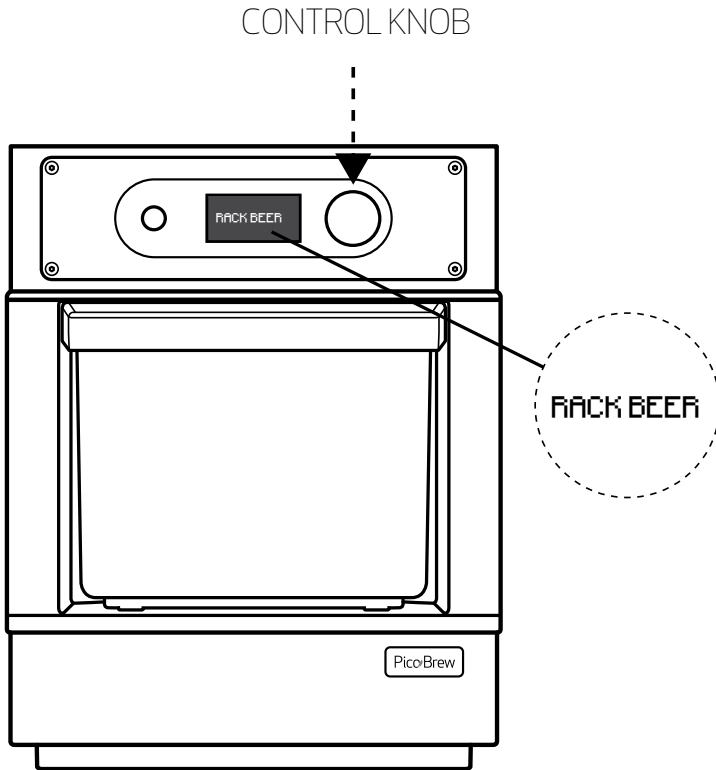

**6** Connect sanitized Keg Wand to the **GRAY** Ball Lock Connector.

Direct the **GRAY** Keg Wand to a waste container. Press the Control Knob to clear the drain hose.

When liquid stops flowing into the waste container press the Control Knob to stop the pump, this should take no more than 1 minute.

Remove the Keg Wand from the Ball Lock Connector.

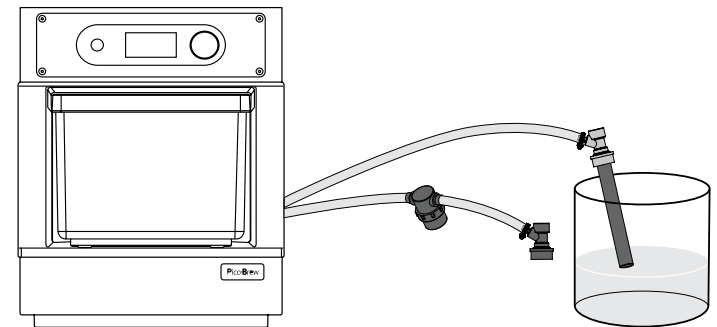

**7** Insert Metal Keg Lid onto Brewing Keg, if not already on. Do NOT use black Keg Seal for the racking process.

Connect the GRAY Ball Lock Connector to the Brewing Keg IN post, this will allow the Pico to pressurize the Brewing Keg with air.

Connect the Transfer Tube to the OUT post of each Brewing Keg. Pull up the Gray Pressure Relief Valve and turn the ring in any direction 90 degrees to relieve built up pressure and restore a steady flow of beer.

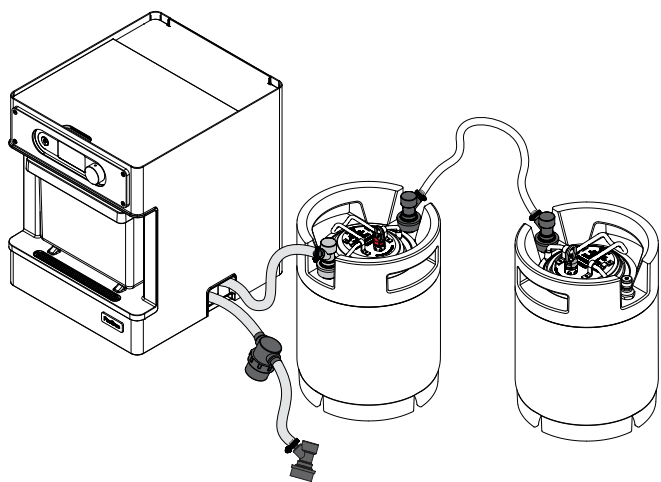

**8** Press the Control Knob to begin transferring beer from the Brewing Keg to the other Brewing Keg you will use for serving. When racking is complete, the Transfer Tube will blow empty. Press the Control Knob to turn off the pump and stop the process. Disconnect the GRAY ball lock connector from the Brewing Keg IN post and the BLACK ball lock connectors from the OUT posts of each keg. Turn the Gray Pressure Relief Valve back 90 degrees to close.

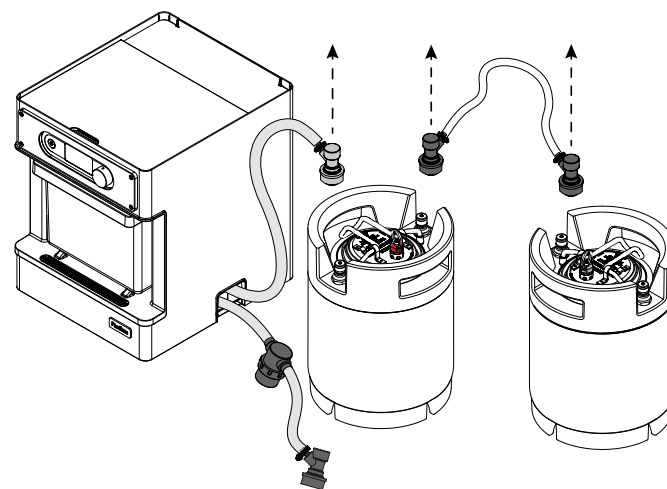



# RACK & CARBONATE YOUR BEER

## STEP 2: FORCE CARBONATE THE BEER

**\*SKIP TO PAGE 103, STEPS 13-15 IF KEG  
CONDITIONING**

**9** Close the CO<sub>2</sub> regulator by turning it counter-clockwise, all the way to the OFF position. If you do not currently have a CO<sub>2</sub> cartridge attached to the regulator, screw a new CO<sub>2</sub> cartridge clockwise into the regulator. The Cartridge will pierce through metal and you will hear a brief air sound. Continue to screw the Cartridge into the Regulator until you can no longer turn it. Insert the ball lock regulator connector into the Brewing Keg IN post.

Slowly dial the Regulator **clockwise** to open the Regulator until it reaches 24 PSI. This is the correct setting for most beers.

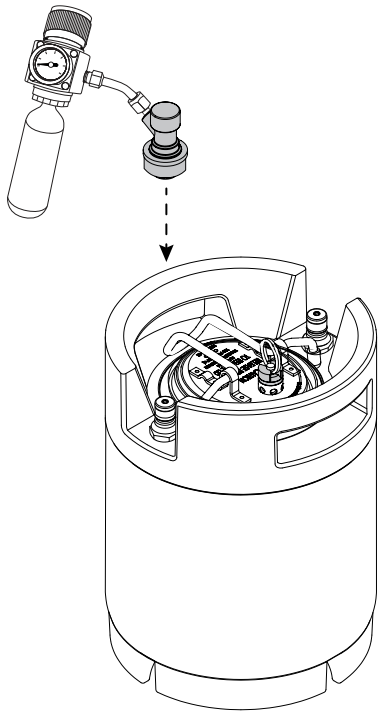

**10** Place the Brewing Keg with attached CO<sub>2</sub> Regulator into your refrigerator to chill and carbonate for approximately 36 hours.

After 24 hours, dial the Regulator counterclockwise until it reaches 12 PSI.

Clean the Brewing Keg used for fermentation and Transfer Tube, see Usage & Care section on page 115.

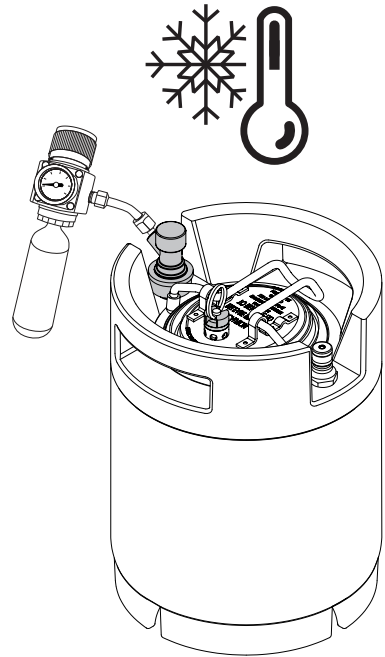

**JIM'S PRO TIP:**



**Cold is faster!**  
In case you didn't know cold liquid diffuses CO<sub>2</sub> quicker, so chill out.

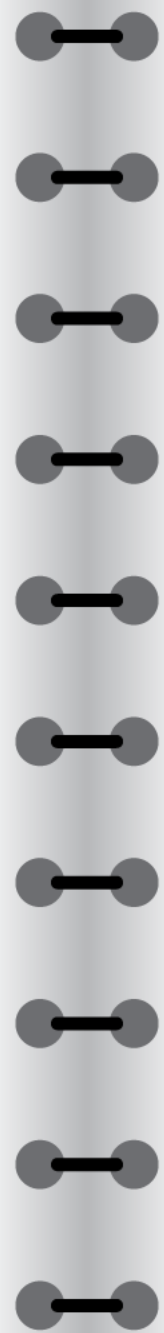

# 11

After approximately 36 hours, slowly dial the regulator counter-clockwise to close it. Keep the CO<sub>2</sub> Regulator connected to the Keg IN post for serving your beer with the Party Tap.

# 12

You can also keep the regulator and cartridge attached to the Brewing Keg for longer term storage. To do so, after the initial 36-hour carbonation period adjust the dial on the regulator from 24 psi to 10-12 psi and maintain at that pressure. This storage method may require more than one CO<sub>2</sub> cartridge.

**Note:** After a few hours in the refrigerator, it is normal that the pressure displayed on the gauge will drop a few psi. Do not adjust the dial during the initial 36-hour carbonation period.

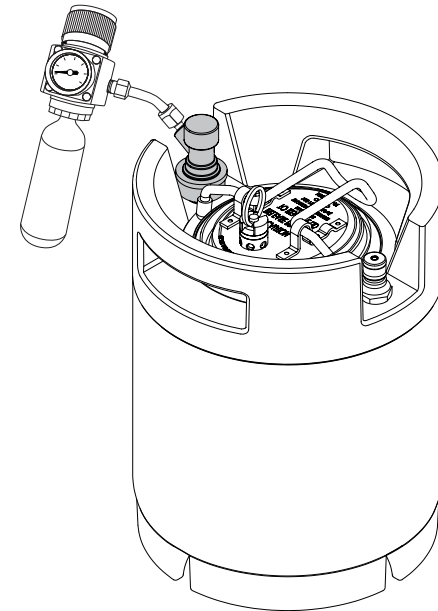



# RACK & CARBONATE YOUR BEER

## STEP 3: KEG CONDITION THE BEER (NATURAL CARBONATION)

**\*SKIP TO PAGE 97, STEPS 9-12  
IF FORCE CARBONATING**

# 13

After Racking is complete, remove the Metal Keg Lid from the Brewing Keg with your beer and pour all contents from the Carbonation Sugar packet into to the keg.

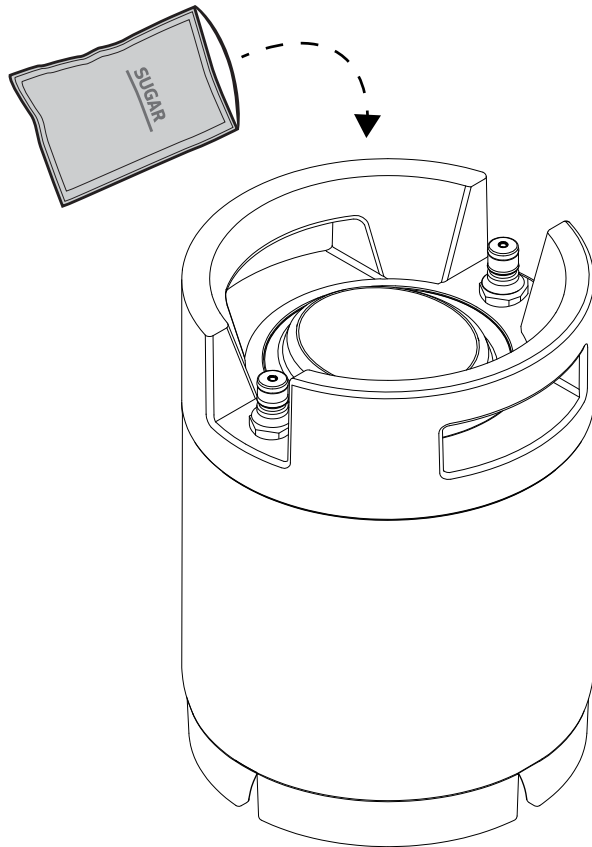

# 14

Insert the Metal Keg Lid with a Gray Pressure Relief Valve to the Brewing Keg, seat it, and clamp it down. Swirl the keg so the Carbonation Sugar and beer are well mixed.

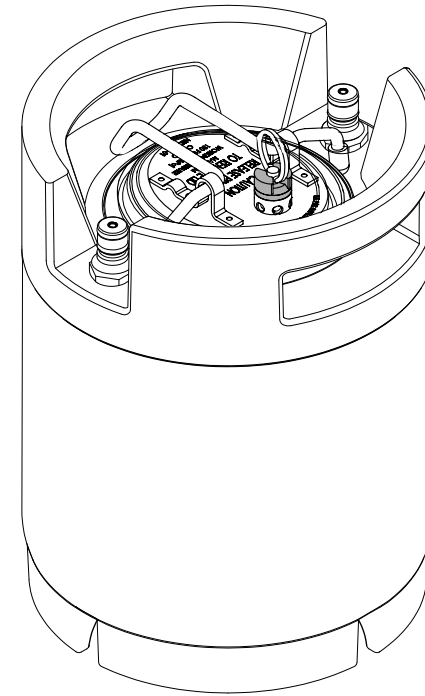

# 15

Set the Brewing Keg aside to carbonate in the same area that you fermented the beer.

**Note:** The amount of time it takes to carbonate should be about twice the amount of time it took for original fermentation. This is based on the carbonation being done at the same temperature as the original fermentation.

Once carbonated, chill for at least 12 hours before serving. Your beer is best kept refrigerated for long term storage.

**PROCEED TO NEXT SECTION:  
SERVE YOUR BEER**





# BOTTLE YOUR BEER

## YOU WILL NEED:

- Your keg of fermented beer
- Bucket
- 1 Liter bottles (x5)
- Carbonation Drops
- Bottling Tube
- Food grade sanitizer prepared according to manufacturer's instructions (Star San is recommended)

\*Bottling accessories sold separately on  
[www.picobrew.com/BrewGear](http://www.picobrew.com/BrewGear)

# 1

Pour  $\frac{1}{4}$  cup of sanitizer solution in each bottle and close the cap. Shake the bottle and let it sit for five minutes. Empty the contents in the bottle in the bucket. Check the bottle for any debris that could contaminate your beer.

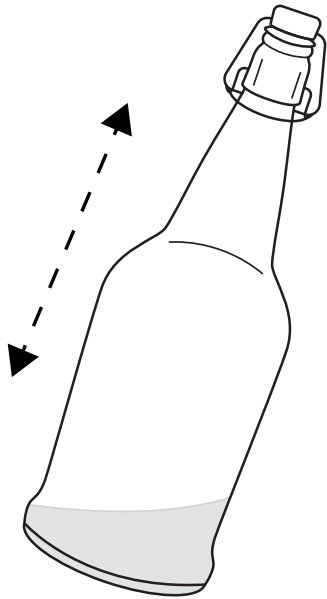

# 2

Attach the Keg Wand to the ball lock fitting on the Bottling Tube. Pour sanitizer solution into the Bottling Tube and press down on the clean bucket to allow sanitizer to flow through.



**3** Place carbonation drops into each bottle. Refer to instructions on packaging to determine how many drops are needed per bottle.

**Note:** If using Coopers carbonation drops, 3 drops per 1 liter bottle is recommended for most beers.

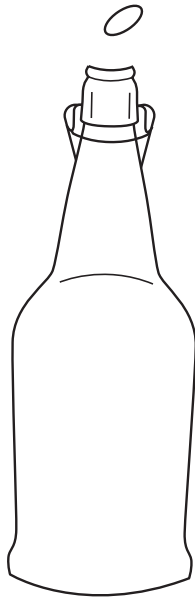

**4** Remove the Brew Keg from your refrigerator. From the Pico main menu select Utilities then select **Rack Beer**. This will provide step-by-step instructions on screen. Press the Control Knob between each step.

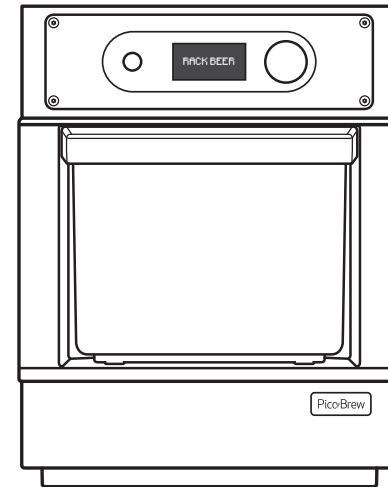

**5** Follow RACK THE BEER instructions in the manual, attaching your Bottling Tube instead of the Racking Tube to the OUT post on the Brew Keg

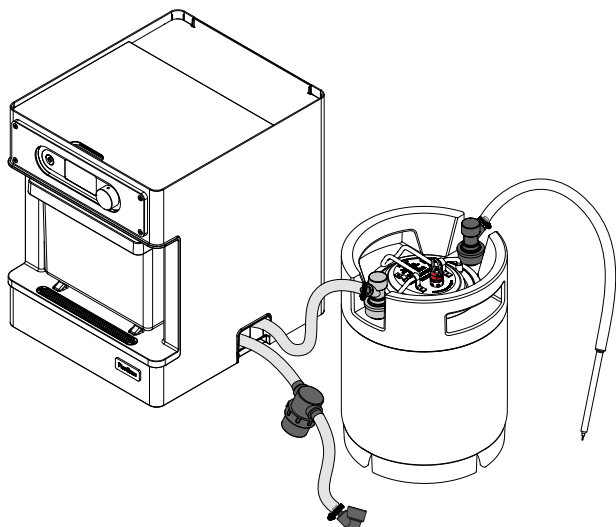

**6** Direct the Bottling Tube to the bottom of the sanitized bucket and press down. Press the Control Knob. The initial beer coming from the Bottling Tube may contain trub (sediment). When no more trub flows in to the waste container press the Control Knob to stop the drain, this should take no more than 30 seconds.

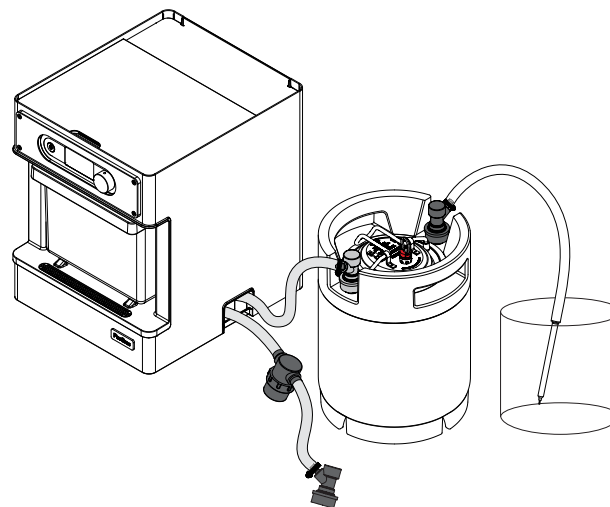

**7** Insert the Bottling Tube into the bottle, place it all the way to the bottom and press to transfer the beer. Fill all the way to the top of the bottle, when the Bottling Tube is removed you will have the correct amount of headspace. Repeat this process until the Brew Keg is empty and air begins to enter the Bottling Tube. Then press the Control Knob to turn off the pump and stop the process, and remove the Bottling Tube from the keg.

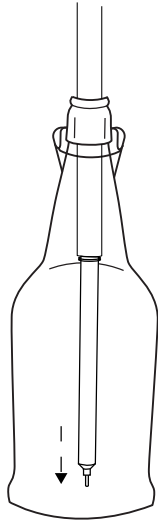

**8** Seal the bottles and rinse off any beer that may have overflowed. Store the bottles in room temperature for 10-14 days. Once carbonated, chill for a minimum of 12 hours before serving.

**Note:** If your beer seems under-carbonated after 10-14 days, move the remaining bottles to a warmer area and continue to carbonate for a few more days.



# SERVE YOUR BEER

**ESTIMATED TIME:  
5 MINUTES**

## **YOU WILL NEED:**

- Your keg of cold, carbonated, delicious beer
- Party Tap
- CO<sub>2</sub> Regulator
- CO<sub>2</sub> Cartridge
- Keg Label
- Glassware

# 1

If you did not force carbonate your beer, take the CO<sub>2</sub> Regulator and turn the Regulator counter-clockwise all the way to close the Regulator. Quickly screw a new CO<sub>2</sub> Cartridge into the Regulator. The Cartridge will pierce through metal and you will hear a brief air sound. Continue to screw the Cartridge into the Regulator until you can no longer turn it. Connect your CO<sub>2</sub> Regulator to the IN post of your Brewing Keg full of carbonated beer.

Pull the Pressure Relief Valve ring after attaching the CO<sub>2</sub> Regulator to release any excess pressure. Slowly dial the Regulator **clockwise** to open the Regulator until it reaches 10-12 PSI.

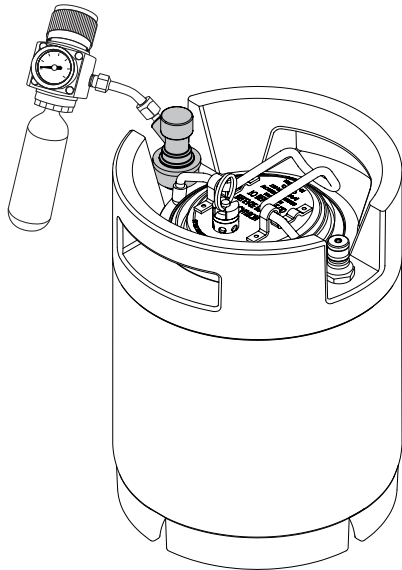

# 2

Attach the Party Tap to the Brewing Keg by connecting the black ball lock connector to the Brewing Keg OUT post.

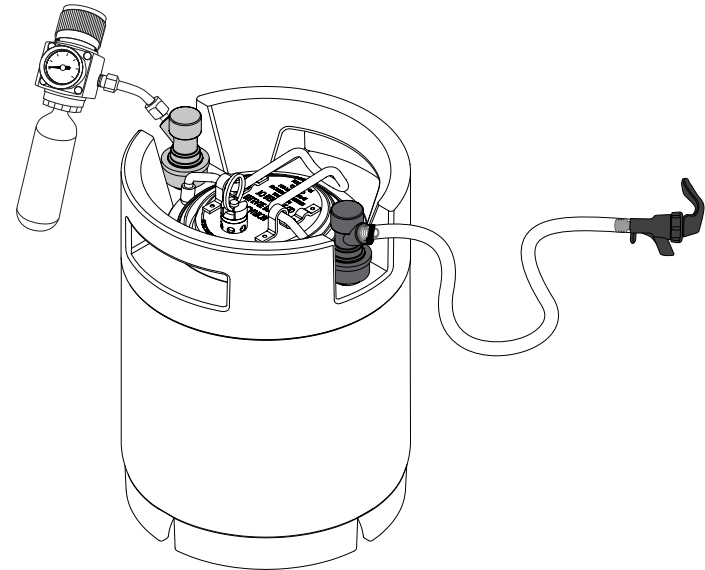

**3** Push the Party Tap handle down to dispense beer and release to stop dispensing. If beer is dispensing too quickly reduce the PSI on the CO<sub>2</sub> Regulator.

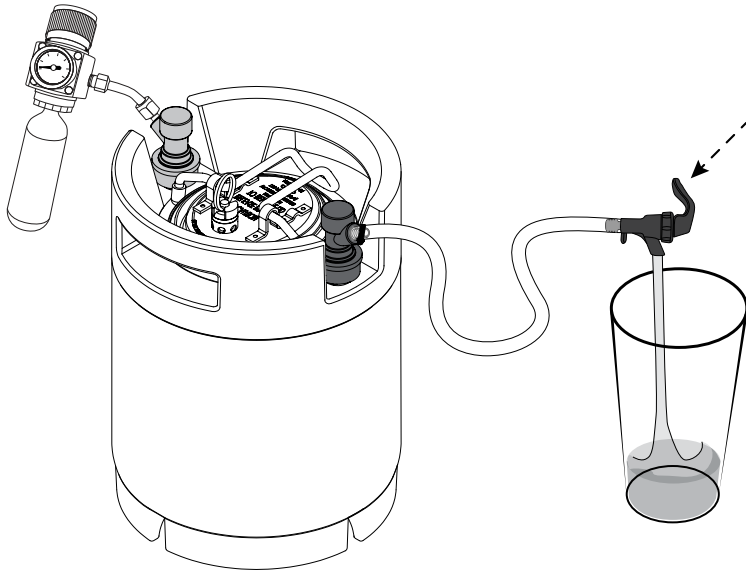

**4** Remove the Party Tap when not serving and refrigerate your Keg.





# WELCOME TO THE HOMEBREW FAMILY

WE'RE A REALLY  
FUN CROWD.

**LET'S  
STOP  
FOR A  
LITTLE  
REFLECTION.**

**YOUR  
FIRST  
OF  
MANY  
BEERS.**

**THE FLOOD  
GATES ARE NOW  
OPEN FOR MORE  
DELICIOUS  
HOMEBREW  
GOODNESS.**



↑  
CHEERS



# USAGE & CARE

**ESTIMATED TIME:  
20 MINUTES**

**RECOMMENDED OCCURRENCE:**

Should be performed after every brewing session, completed fermentation, or when keg is empty.

- Remove Step Filter from Pico. Wipe down any condensation that has formed inside Pico where Step Filter usually sits.
- Wipe down the inside of the Water Reservoir.
- Clean out the Inline Filter.
- Inspect gaskets on Inline Filter, ball locks, Brewing Keg posts.
- Tighten Inline Filter, ball locks, keg posts.

# KEG CLEANING:

**KEGS SHOULD BE CLEANED EVERY TIME THEY ARE DONE BEING USED, AFTER FERMENTING OR WHEN KEG IS EMPTIED.**

## **YOU WILL NEED:**

- 17mm wrench
- Brewing Keg
- All accessories used during brewing, fermentation, or serving (Metal Keg Lid, Black Keg Seal, Fast Fermentation Adapter, Pressure Relief Valve, Airlock, etc.)
- Keg Brush and Dip Tube Brush
- Large-sized container
- Fragrance-free powdered dishwasher detergent, or other homebrewing cleaning agent
- Racking Tube
- Keg Wands

# LET'S START THIS ADVENTURE WITH OUR BREWING KEG.

## **LINDSEY'S PRO TIP:**

After a keg has kicked give the keg a quick rinse with hot water, put the lid on and give it a good shake. This will make clean up easier if you can't get to cleaning the keg right away. Never leave old beer in the keg to clean later!

- 1** Fill a large container with  $\frac{1}{4}$  teaspoon fragrance-free powdered dishwasher detergent and enough hot tap water to almost fill container.

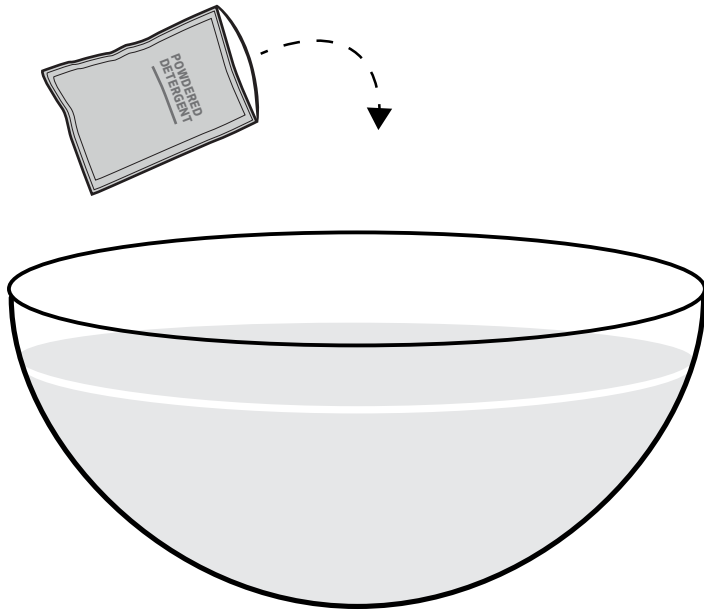

- 2** Place all accessories used during brewing or fermentation in to the container to soak. Use Keg Brush to clean all items inside container, making sure to scrub any surface that may have had any contact with beer.

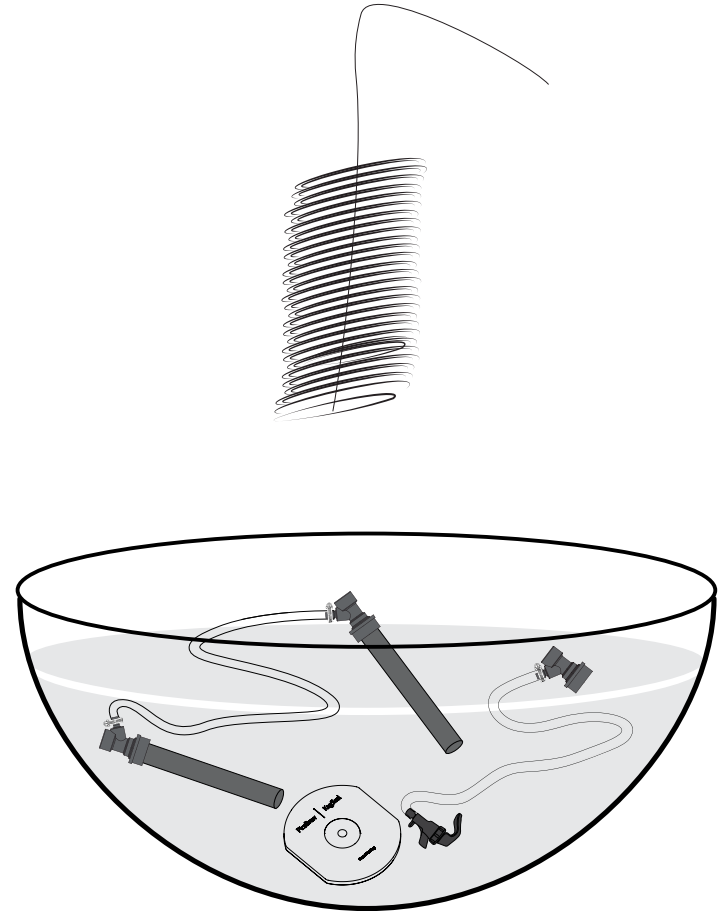

**3** Remove one of the keg wands from the Transfer Tube and attach it to the Party Tap. Let it soak and push the Party Tap handle down to rinse out the hose.

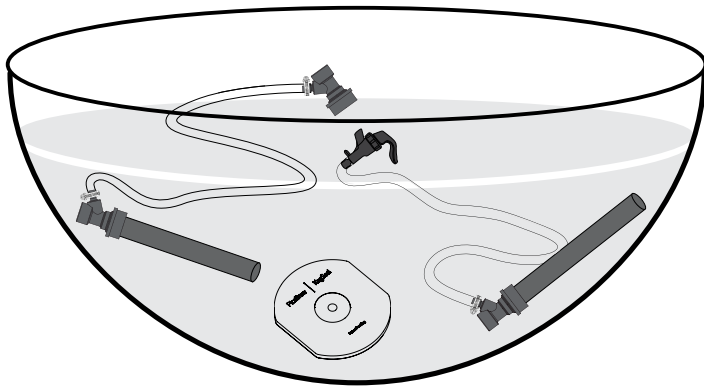

**4** Add 1 teaspoon of Hydrogen Peroxide and 1 teaspoon of water in the keg wand attached to the Party Tap. Remove the Keg Wand from the Party Tap and leave Hydrogen Peroxide in the Party Tap line to sanitize.



**5** Store Party Tap with Hydrogen Peroxide solution in the line until next use. Before dispensing, attach keg wand to ball lock connector on Party Tap and push Party Tap handle down to flush out Hydrogen Peroxide solution.

**Note:** If using StarSan, do not store the solution in the Party Tap line for more than 5 minutes.

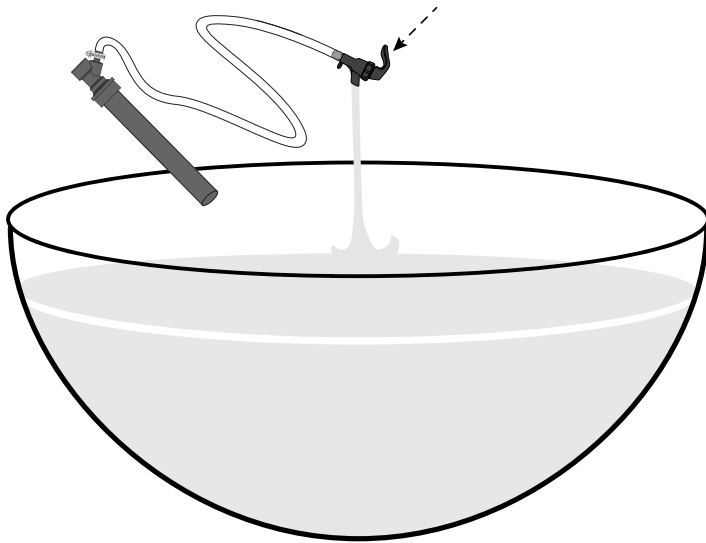

# STOP! BEFORE GOING FURTHER REMOVE YOUR BREWING KEG POSTS:

We recommend removing one post at a time so that there is less confusion and chance of putting the IN on the OUT post or vice versa when reassembling. There are subtle notches on the outside edges of the IN Keg Post Ball Lock in case you want to remove both posts at one time.

# 6

Use a 17mm wrench to remove Keg Posts.

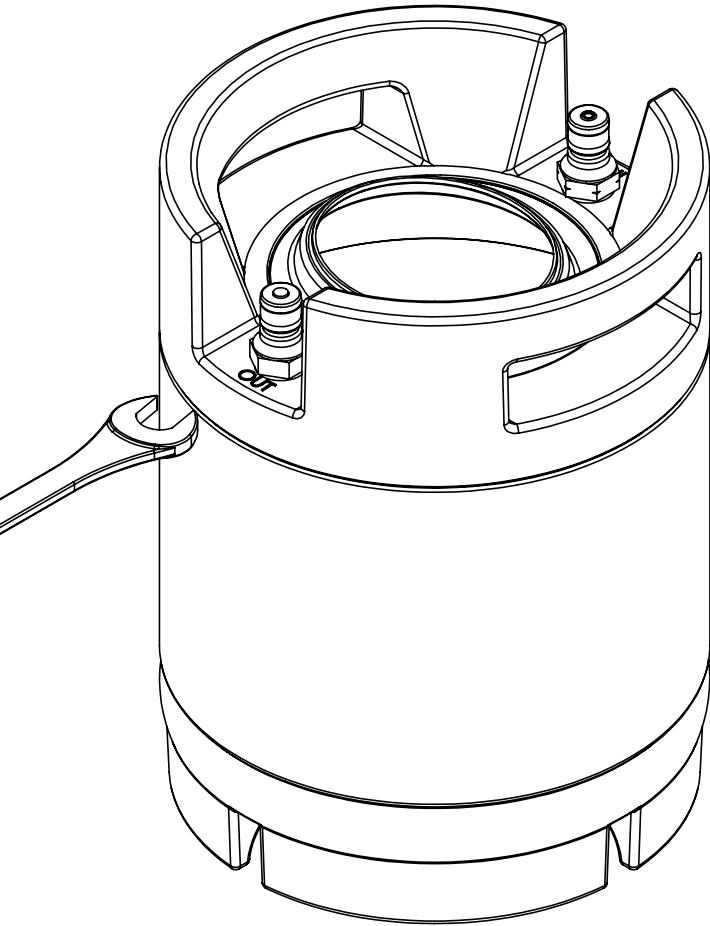

# 7

**CAREFUL!** There is a metal spring and valve inside both the IN and OUT post Ball Locks, this is called the Poppet Valve. It may jump out as soon as the IN or OUT posts are taken off. Make sure you are standing over a contained area, not a sink with an open disposal or drain, nor a patterned carpet.

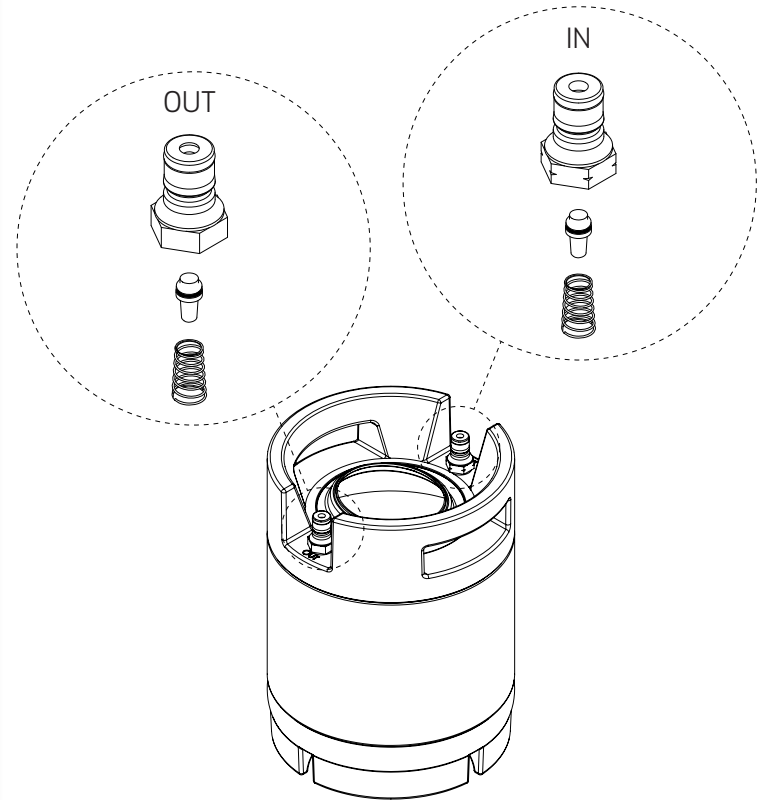

**8** The IN post is connected to a short tube. Remove the black O-ring attached to this tube.

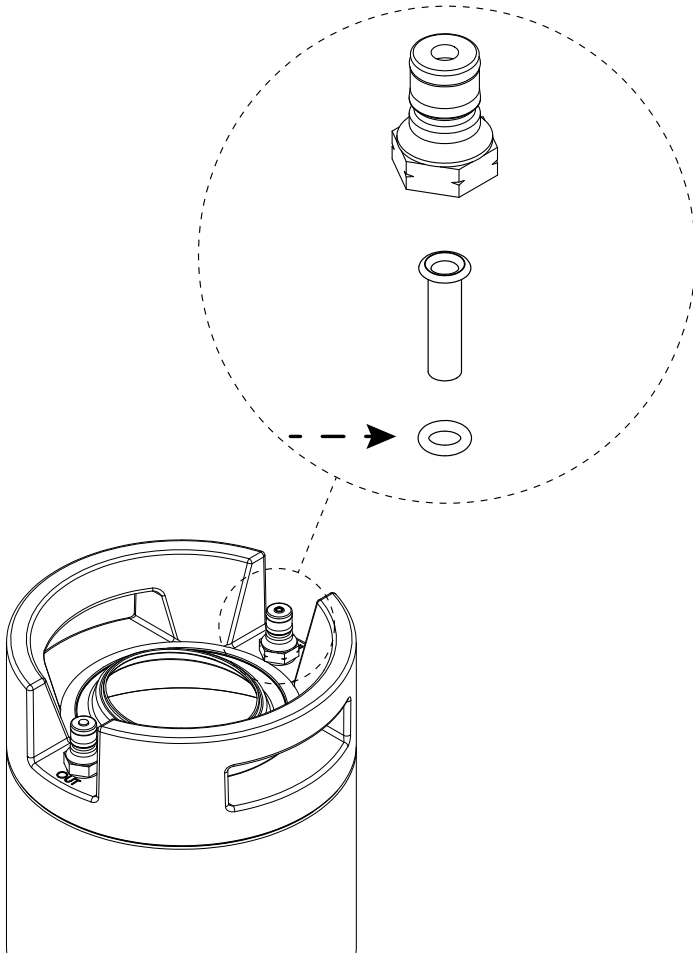

**9** The OUT post is connected to a long Dip Tube that reaches the bottom of the keg. Remove the black O-ring attached to this tube.

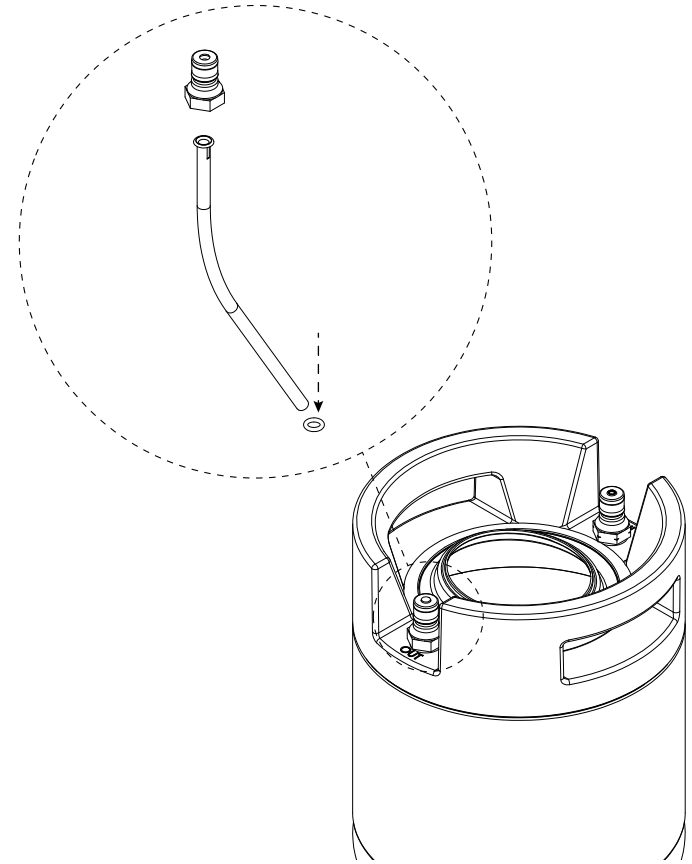

# 10

Use the Dip Tube Brush to clean the inside of Keg IN/OUT Posts thoroughly. Place all parts but the Dip Tube in to container and let soak.

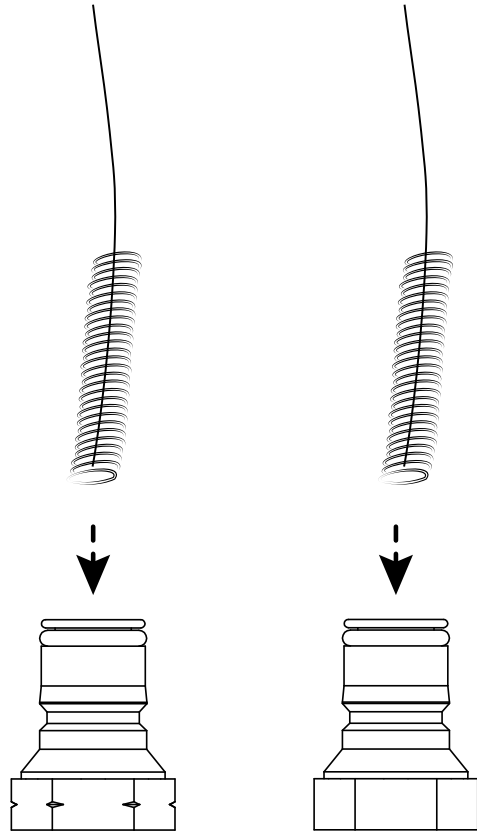

# 11

Inside the Brewing Keg mix  $\frac{1}{2}$  teaspoon powdered dishwasher detergent with enough hot tap water to almost fill the keg. Place the Dip Tube in the Brewing Keg and let soak for 10 minutes, longer if there is hardened build-up.

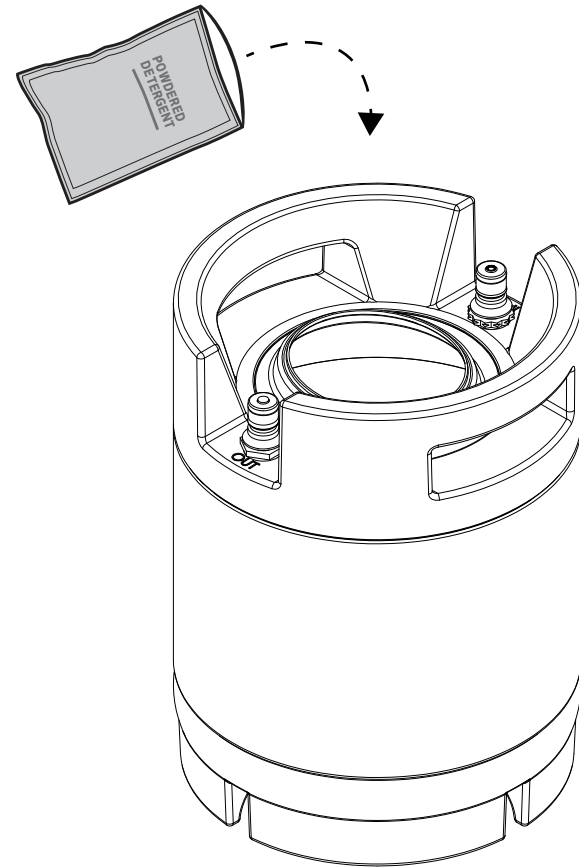

# 12

Use the Keg Brush to scrub the inside of the Brewing Keg, making sure to get in contact with all internal walls and crevices of keg, and the outside of the keg making sure to get the top opening and any spot that had contact with beer. Use Dip Tube brush to clean the Dip Tube.

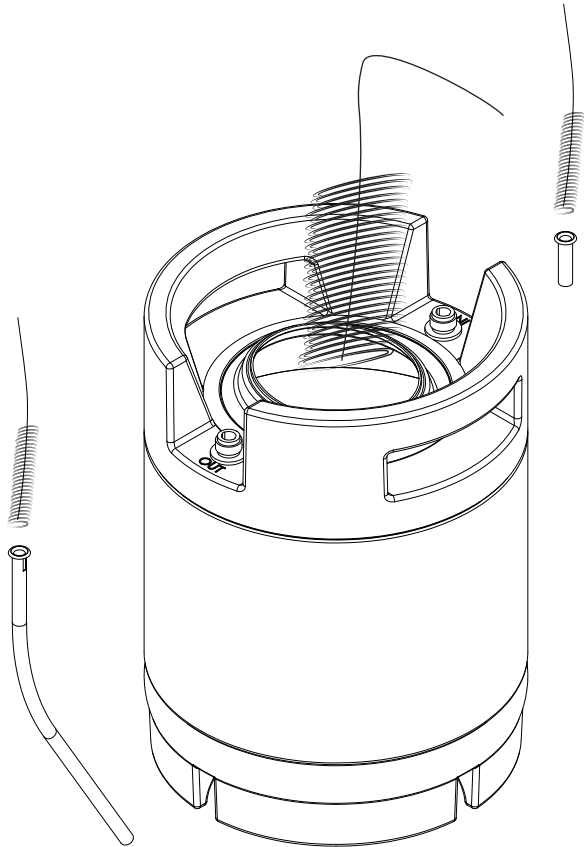

# 13

Rinse the Brewing Keg thoroughly with clean water.

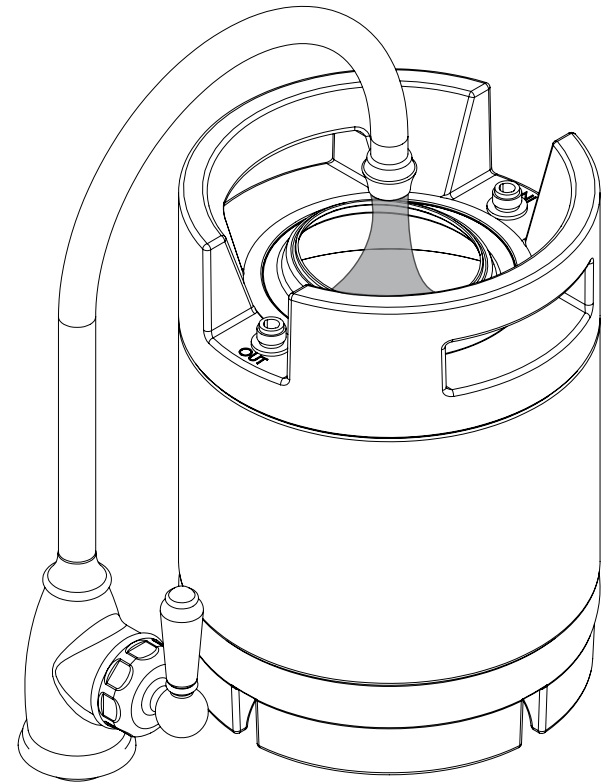

# 14

Reassemble all O-rings to their original part locations. When reassembling the O-rings make sure to use either water or a food-grade lubricant to ease them back into place.

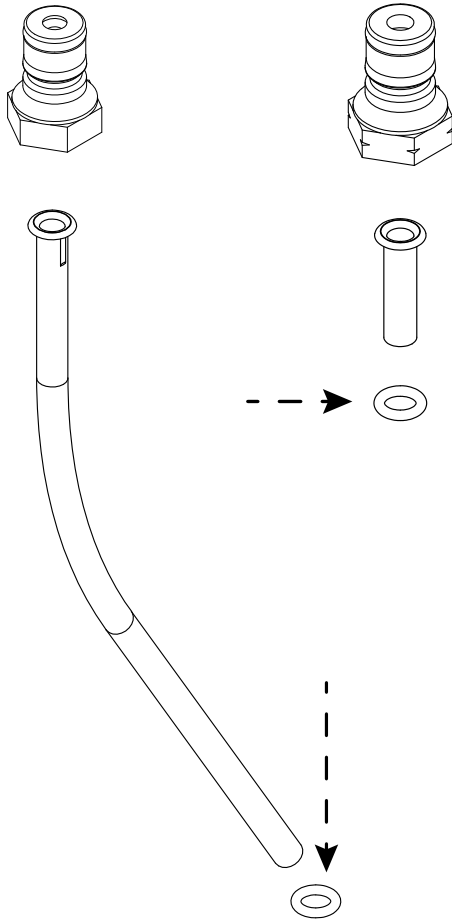

# 15

Make sure the IN/OUT keg posts are on the correct sides and are tightened down. Remember, the tube for the IN post is shorter than the Dip Tube for the OUT post. The Dip Tube is slightly angled and the end of it should almost touch the center of the bottom inside the Brewing Keg.

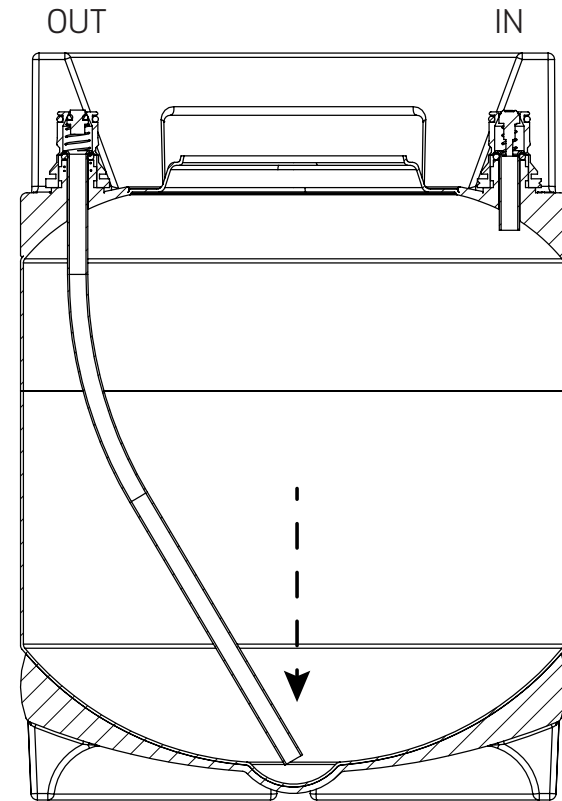



**REMEMBER:  
NEVER  
USE  
ANY  
CLEANING  
AGENT  
INSIDE  
THE  
PICO  
UNIT.**

**POWDERED DETERGENTS  
OR DRY PACKS SHOULD  
ALWAYS BE USED  
IN CONTAINERS  
SEPARATE FROM  
THE PICO, LIKE A BUCKET  
OR BREWING KEG.**



# PICO DEEP CLEAN

**ESTIMATED TIME:  
HANDS ON 10 MINUTES  
(TOTAL TIME: 45 MINUTES)**

## **RECOMMENDED OCCURRENCE:**

Should be performed every 3 brew sessions.

## **YOU WILL NEED:**

- 1 gallon of clean tap water
- 0.5 gallon of distilled water (or reverse osmosis)
- Brewing Keg
- Keg Cozy
- Keg Wands
- Waste Container
- 1 solid dishwashing cleaning tablet  
(do NOT use liquid or gel pouches or any common homebrew cleaning agents)

# DEEP CLEAN CYCLE:

# 1

Pour 1 gallon of clean tap water into the Brewing Keg. Slide the Keg Cozy over the Brewing Keg. Drop the solid cleaning tablet into the Brewing Keg. You can leave the keg lid or seal off during the Deep Clean cycle.

**Note:** The cleaning tablet should ONLY go in the Brewing Keg. Never put it or any other cleaning agent inside the Water Reservoir or Step Filter.



**2** Connect the BLACK Ball Lock Connector to the OUT post on the Brewing Keg. Repeat procedure with the GRAY Ball Lock Connector to the IN post.

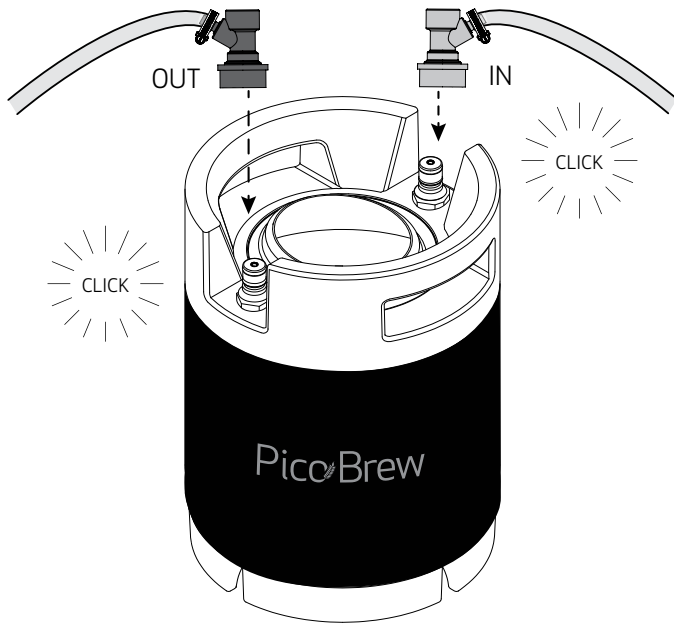

**3** Insert the Step Filter with lid into Pico. Turn Pico on. Click Utilities and select DEEP CLEAN.

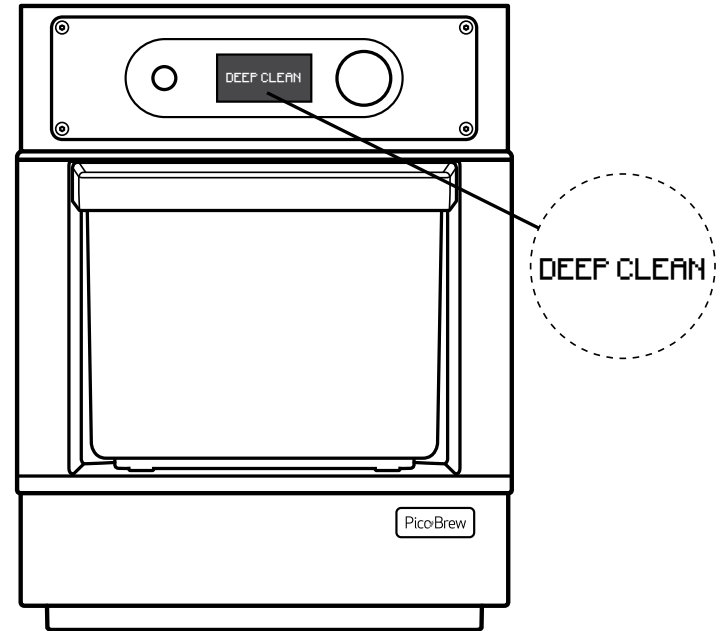

**4** Pour 0.5 gallon of distilled water into the Water Reservoir.

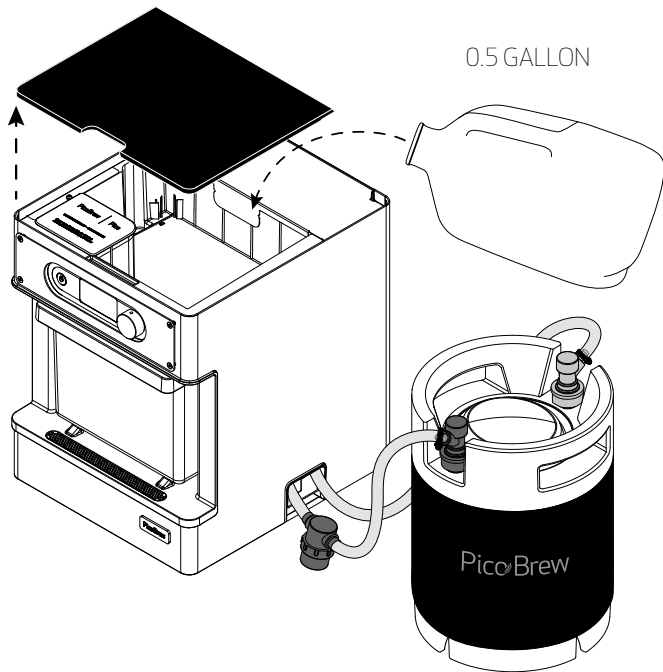

**5** Once the Deep Clean cycle begins it will take roughly 35 minutes to complete.

**Note:** The Brewing Keg will be very HOT after cleaning so please proceed with caution and only touch the keg's black rubber handles.



# RINSE CYCLE:

- 6 Once Deep Clean cycle finishes, carefully dump all liquid from both the Step Filter and the Brewing Keg. Liquid will be HOT so use caution! Rinse thoroughly with clean water. Fill the Step Filter with approximately 1 inch of clean tap water, then insert the Step Filter with lid back into Pico until it clicks into place.

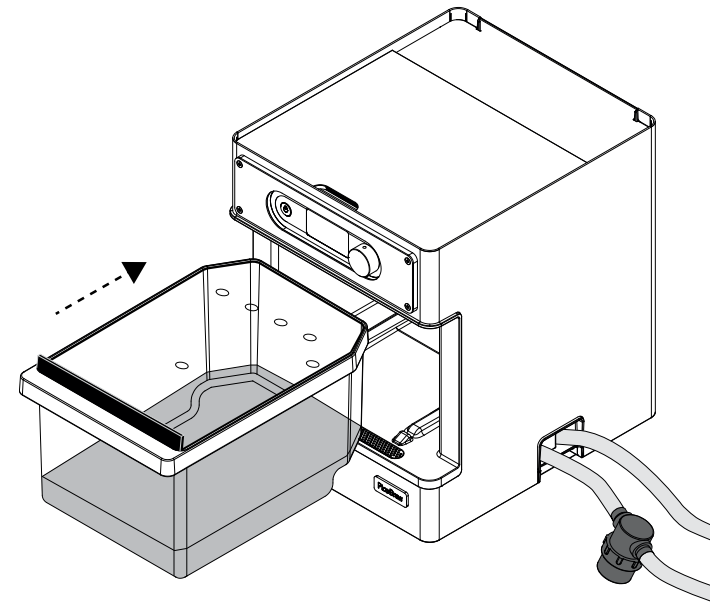

TAP WATER

**7** For each Ball Lock Connector, pull up on the outer ring of the Connector and insert a Keg Wand, release the ring and make sure it is properly connected to the Keg Wand.

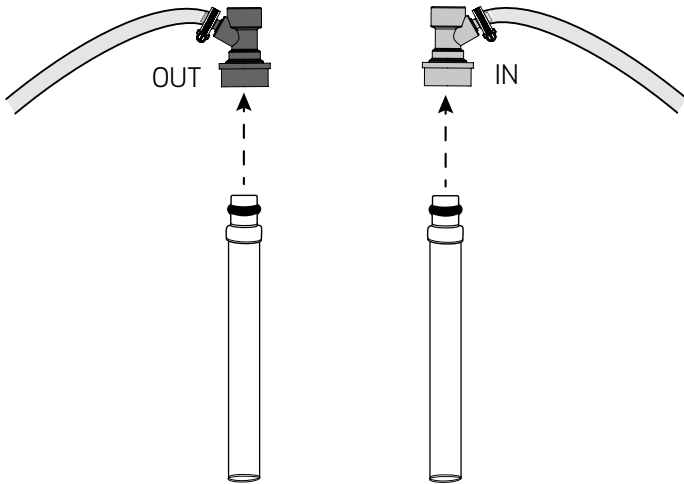

**8** Direct the end of the GRAY Ball Lock Connector ("IN") Keg Wand into a waste water container.

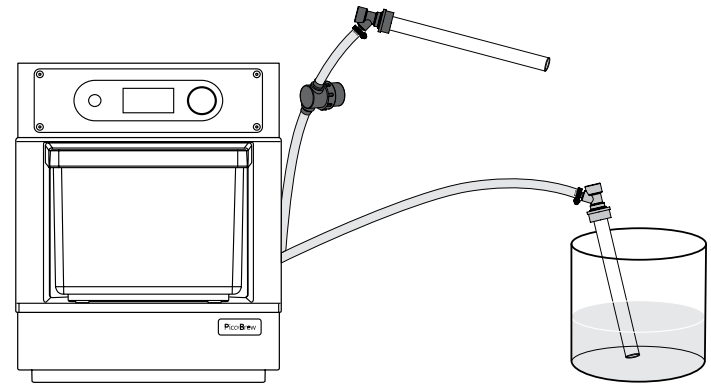

### **BILL'S PRO TIP:**

Make sure you use a big enough waste water container! The gallon water jug you used to fill the machine is perfect for this use.

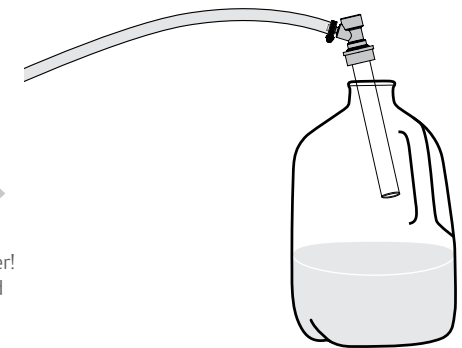

# 9

Press Control Knob to start Rinse Cycle and run the pump to clear the drain line.

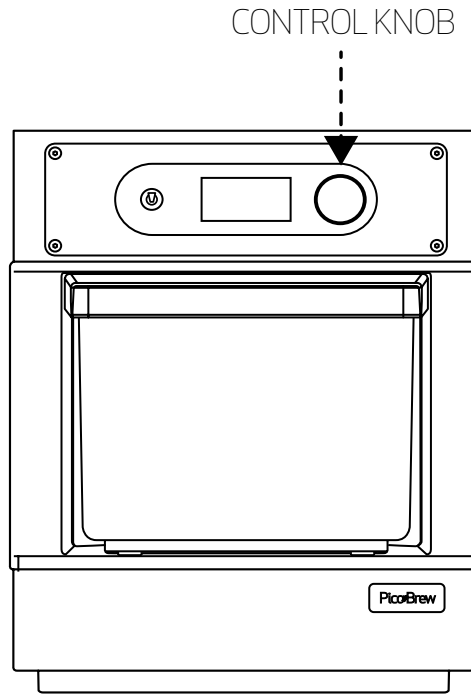

# 10

Remove the Water Reservoir lid. Insert the end of the BLACK Ball Lock Connector ("OUT") Keg Wand into the Water Reservoir. Run the pump until the Reservoir is drained. When the Reservoir is empty stop the pump by pressing the Control Knob.

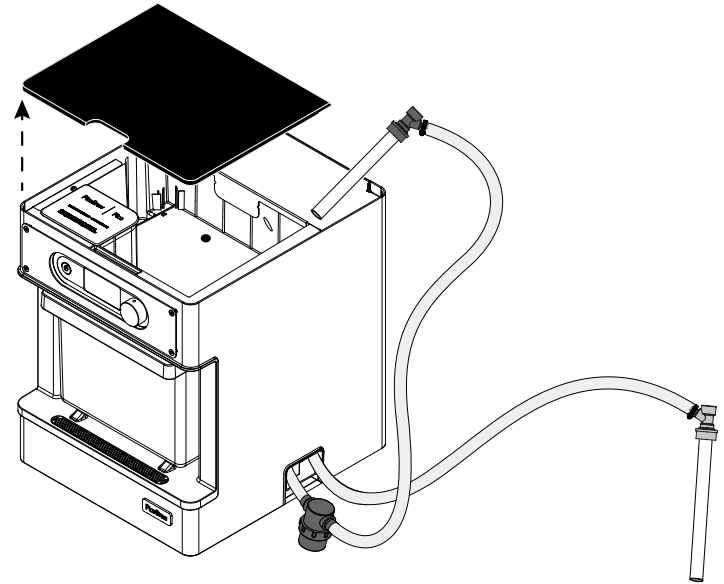

# 11

Press the power button on the Pico to turn it off.

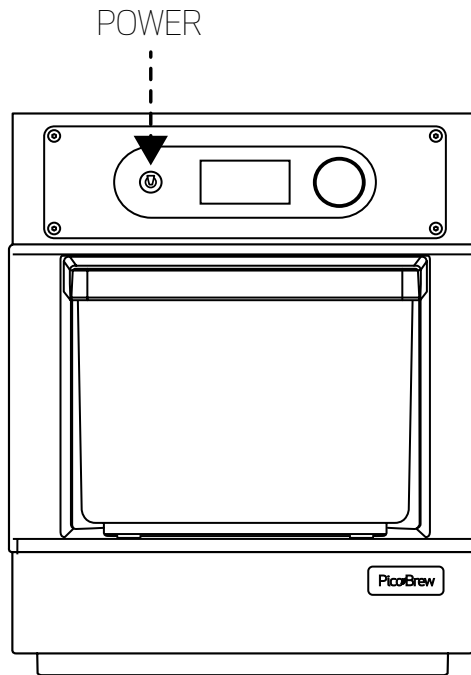

# 12

Unscrew and remove the Inline Filter cap. Remove the blue Inline Filter cylinder and rinse it thoroughly using tap water. Put the cleaned cylinder back into the Inline Filter and screw the Filter cap back on, finger tight.

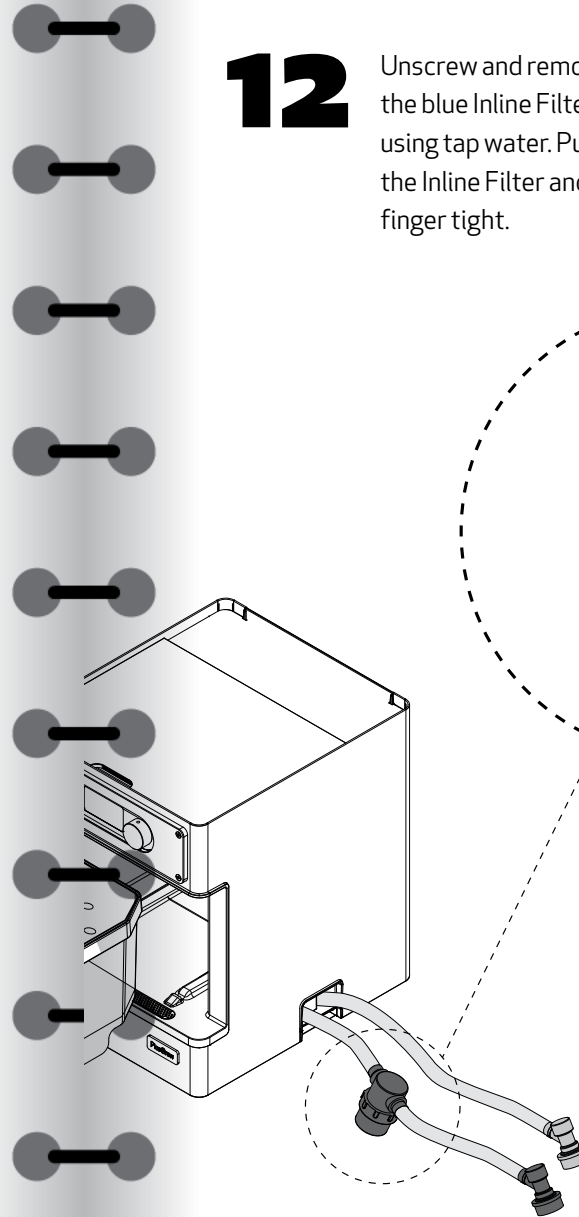

# 13

Remove the Keg Wands from the Ball Lock Connectors by pulling up on the outer plastic rings. Remove the Step Filter and lid from the Pico and rinse thoroughly with tap water.

**Note:** If your Brewing Keg is already being used, use a clean container that can hold up to 1.5 gallons and can withstand temperatures up to 135°F. The container and liquid will be hot, so please exercise caution while handling. You will need both Keg Wands, which will need to be attached to the BLACK and GRAY Ball Lock Connector hoses and directed into the container. The Keg Wand attached to the BLACK Ball Lock Connector will suction water out of the container, so make sure the end is submerged enough to suction water. The Keg Wand attached to the GRAY Ball Lock Connector will recirculate water into the container, so make sure its end is directed inside the container.



# STEP BY STEP:

**1.** Pour 14 ounces of Descaling Liquid into the Water Reservoir. Fill the rest of the Water Reservoir with clean tap water (approximately 1 gallon).

**2.** Insert the Step Filter with lid into the Pico. Turn Pico on. Click Utilities and select RUN DESCALER.

**3.** Once the descaling cycle begins, it will take roughly 30 minutes to complete. When the Water Reservoir is empty press the Control Knob to end the cycle.

**4.** Once the descaling cycle finishes, carefully empty all liquid from the Step Filter. Fill the Water Reservoir with 1 gallon of clean tap water. Insert the Step Filter with lid back into the Pico until it clicks into place. Press the Control Knob to continue. When the Water Reservoir is empty (after approximately 30 minutes) press the Control Knob to end the cycle.

**5.** Run a Deep Clean on your Pico by following the Deep Clean instructions in the manual.

# PICO DESCALE

**ESTIMATED TIME:  
HANDS ON: 10 MINUTES  
(TOTAL TIME: 1 HOUR)**

## RECOMMENDED OCCURRENCE:

Should be performed after every 20 brews if you are not using distilled or reverse osmosis water in the Water Reservoir.

## YOU WILL NEED:

- 14 oz. Descaling Liquid (Available on [www.picobrew.com/BrewGear](http://www.picobrew.com/BrewGear))
- 2 gallons of clean tap water



# SAMPLE RECIPES:

			RARE	MED	WELL
	SIZE	TIME	TEMP	TEMP	TEMP
<b>STEAK</b>	1" Thick	1:00	129	136	154
	1.5" Thick	1:30	129	136	154
	2" Thick	2:00	129	136	154
<b>PORK CHOP</b>	1" Thick	1:30	136	143	158
<b>BONELESS CHICKEN BREAST</b>	0.5 lb	1:30	140	150	165
<b>SALMON</b>	1" Thick	0:40	105	123	131
	1-2" Thick	1:00	105	123	131
		<b>TIME</b>	<b>SOFT</b>	<b>MED</b>	<b>HARD</b>
<b>EGGS</b>	(4)	0:20	167		
		0:25		168	
		0:40			168

## RECOMMENDED:

All temperatures are listed in degrees Fahrenheit.

# SOUS VIDE ADAPTER INSTRUCTIONS.

## YOU WILL NEED:

- Pico, with Step Filter and its lid
- Brewing Keg
- Keg Cozy
- Sous Vide Adapter
- 1 gallon of Distilled Water
- Tap water
- 1 gallon heavy duty Ziploc® bag or a food vacuum sealer system
- Food to cook
- 5 quarts of tap water

# 1

Fill the Brewing Keg with 5 quarts of warm tap water.

**Note:** 5 Quarts = 1.25 Gallons = One Gallon + 4 Cups = 20 Cups = 10.5lbs Water = 4.75 Liters

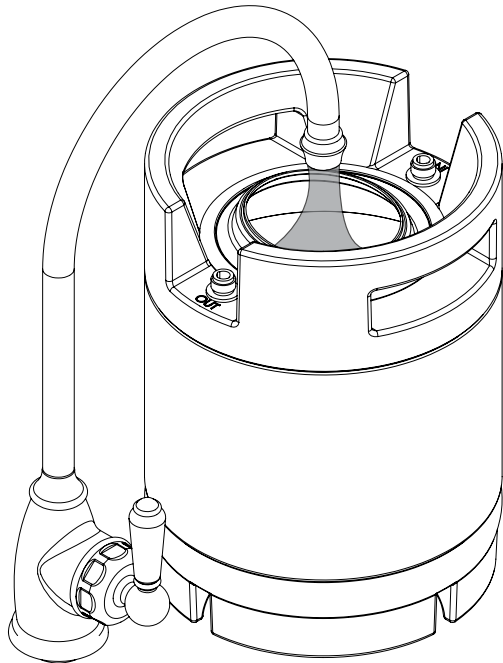

# 2

Place the black Keg Seal on the top of the Brew Keg opening, push in the center until it pops into place. Make sure the hole in the center of the Keg Seal is open. Pull the Keg Cozy over the Brewing Keg. Attach the BLACK Ball Lock Connector hose connector to the Brewing Keg post marked "OUT". Repeat the procedure with the GRAY Ball Lock Connector hose (capitalize) on the brew keg post marked "IN".

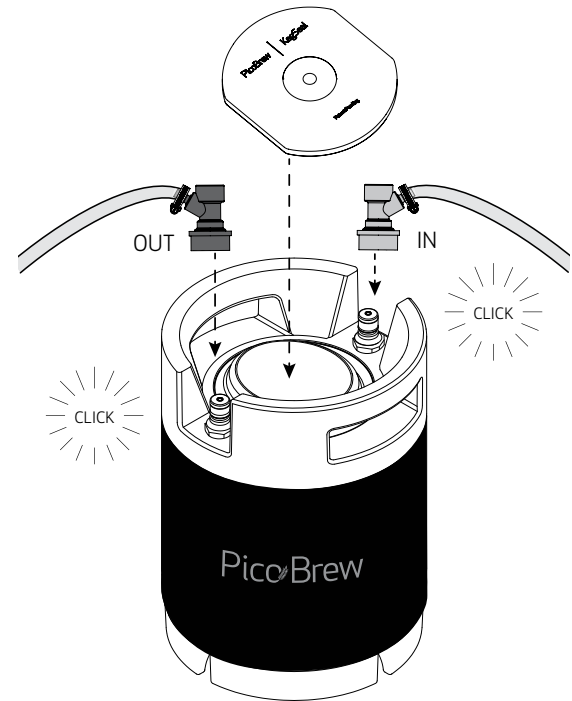

**3** Turn the Pico on. Using the Control Knob scroll to **Sous Vide** and press Control Knob to select.

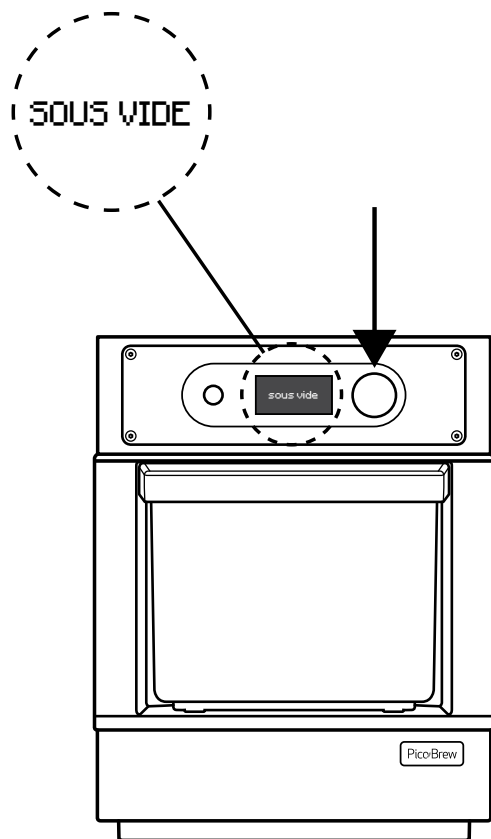

**4** Consult the Sous Vide Recipe Table on page 156 for the food you are cooking.

Set the desired water temperature for cooking by turning the Control Knob to scroll to the correct temperature and pressing the Control Knob to select and continue to the next step.

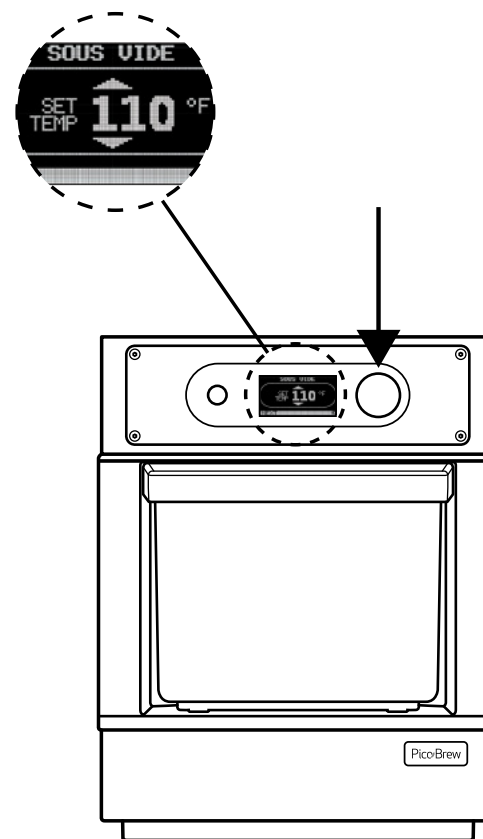

- 5** Enter the cooking time of your recipe in **Hours:Minutes** format by turning the Control Knob to scroll to the correct hour or minute and pressing the Control Knob to select and continue to the next step.

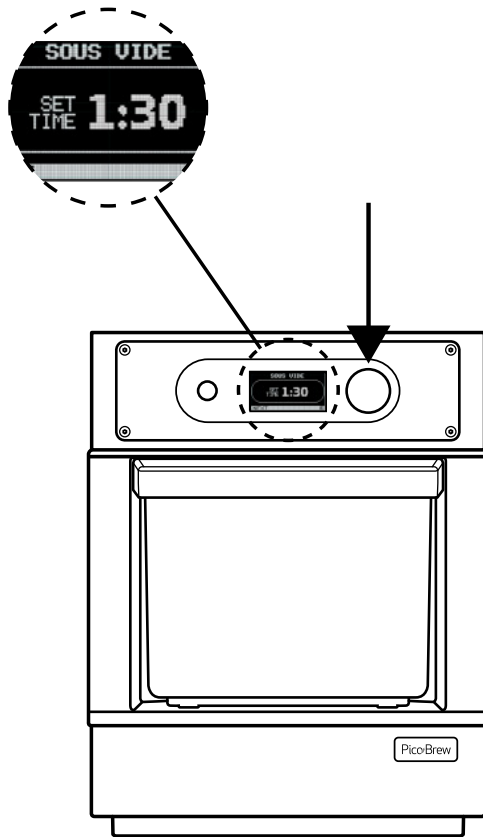

- 6** Insert the empty Step Filter and lid into the Pico, press Control Knob to continue to the next step.

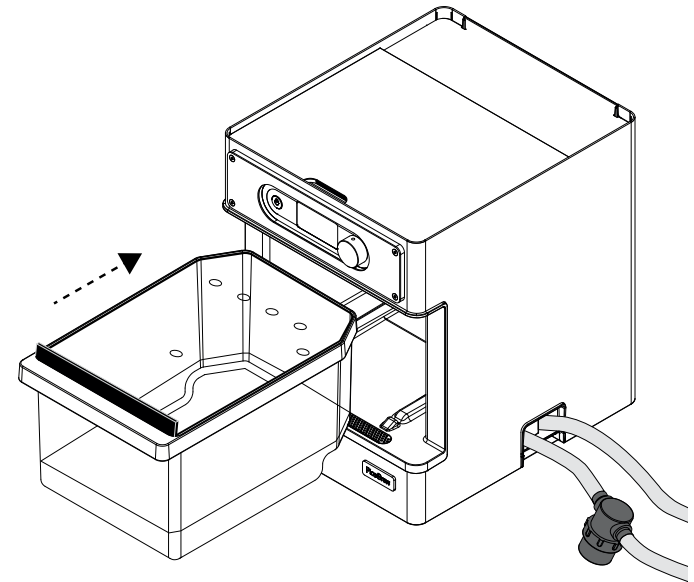

**7** Make sure your keg is properly connected and filled with 5 quarts of water, press the Control Knob to continue to the next step.

Open the Water Reservoir lid on top of the Pico and fill the reservoir with 1 gallon of distilled (or RO) water. Press the Control Knob to begin heating up the water to the designated cooking temperature. For sous vide recipes or cooking sessions that go over 3.5 hours you might need to add more distilled water to the reservoir during the cooking process, check on it as needed.

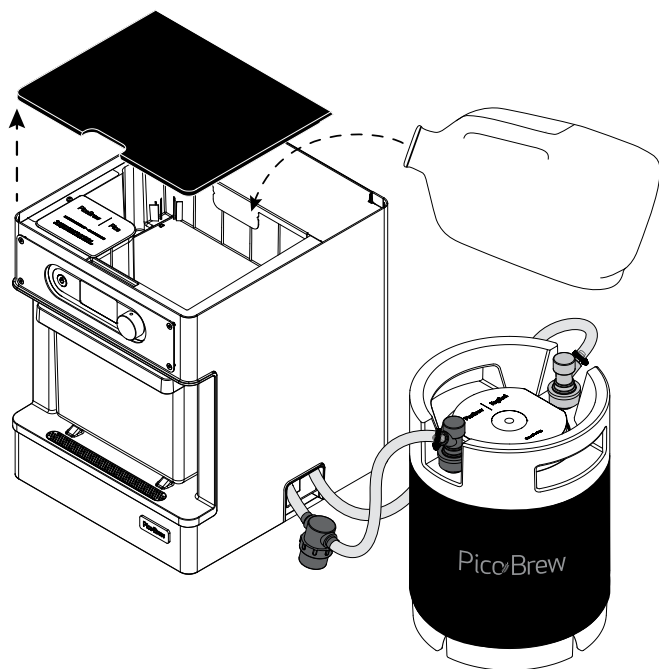

**8** Begin preparing your food:  
Trim and prepare food for cooking. Thicker cuts of meat or vegetables may require longer cooking time. Add any spices or aromatic to the food before sealing the bag(s).

Vacuum seal the food or insert into a 1 gallon heavy duty freezer Ziploc® bag with the air squeezed out and fully sealed.

## LINDSEY'S PRO TIP:

To get most of the air out of a Ziploc bag seal the bag but leave about 1" of bag unsealed. Submerge Ziploc® bag of food in water and as the bag submerges the water pressure will squeeze the air out for you. Right before the bag is fully submerged seal up that last 1" of the bag and pull out of water. The bag should be mostly air-tight and ready to sous vide.

# 9

When the water has reached cooking temperature the Pico will beep. Press the Control Knob to silence the alarm. Remove the Step Filter and its lid from Pico. Place the Sous Vide Adapter in the back section of the Step Filter so the hole on the backside of the Adapter covers up the drain hole in the back of the Step Filter. The tapered front of the Adapter should be facing the front of the Step Filter. Press down so the Adapter is firmly in place. See below diagram.

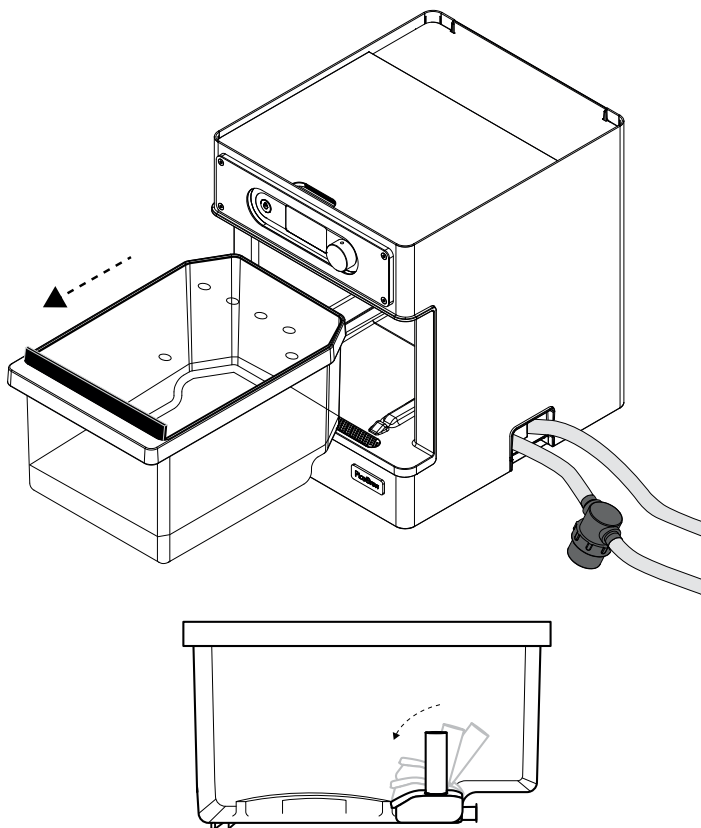

# 10

Place food bag(s) in Step Filter. If using a Ziploc® bag, place bag(s) against the side of the Step Filter with the top hanging out over the edge of Step Filter. Once you place the Step Filter lid on it will clamp the bag(s) into place. Vacuum sealed bags should sink to bottom. If necessary, place a food-safe object on top of bag(s) to make sure they will stay fully submerged in the water during the entire cooking process. Place lid on Step Filter, clamping any Ziploc® bags in place. Make sure the lid holes are in the correct places (see diagram) and that the black steam deflector is towards the front and facing upward.

Insert Step Filter with lid into Pico.

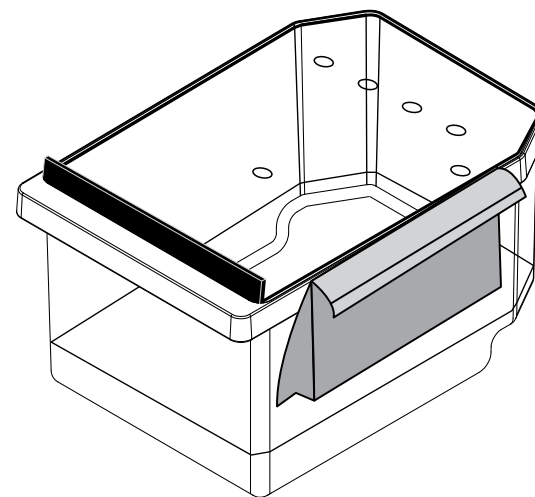

# 11

Select “Start Cooking” on-screen by pressing the Control Knob. This will begin the sous vide cooking process using the time and temperature you selected. You will be able to view the temperature and remaining cooking time on the Pico screen. If at any time you need to pause the cooking process turn the Control Knob to reveal the “Pause System” option and press Control Knob to select and pause cooking. When ready to resume cooking make sure the Step Filter is inserted correctly then select “Continue Cooking” on-screen using the Control Knob.

When Pico is finished cooking the screen will say “Finished” and an alarm will sound for 60 seconds. You can turn the alarm off by pressing the Control Knob.

If you plan on searing any food after cooking make sure to prepare the pan or grill a few minutes before the Pico is finished cooking your food. A simple way to sear meat is to use a heavy pan on your stovetop. Heat the pan on high until hot, add butter/oil and then sear the meat 1-2 minutes per side until the desired sear is achieved.



When the sous vide process is finished:

- You can select “Drain” option on-screen and this will drain water from Step Filter to Brewing Keg, this step makes it easier to get the Step Filter out without spilling water. Use tongs to take food out of Step Filter.
- Or, select “Exit” on-screen and carefully remove Step Filter from Pico, be cautious as the water inside will be warm. Use tongs to take food out of Step Filter.
- Cut open vacuum-sealed bag(s) or open Ziploc® bag(s). Dispose of bag(s).
- Season food to preference. Sear on hot pan or grill (optional).

**Note:** If you do not exit after the cooking is finished Pico will automatically hold the cooking temperature. Any food still in the Pico will continue to cook.

# 12

Disconnect both Ball Lock Connector hoses from Brewing Keg. Dispose of water in both Step Filter and Brewing Keg.

If you plan on doing another sous vide session right away you can reuse the distilled water in the Water Reservoir, check to see if you need to add more. If you are not going to do another sous vide session insert an empty Step Filter back into the Pico. Detach the BLACK Ball Lock Connector hose from the Brewing Keg. Attach a clean Keg Wand to the BLACK Ball Lock Connector and direct the wand into the Water Reservoir. Select "Start Vacuum" to begin suctioning out the remaining water and press the Control Knob to stop the vacuum when there is no more water in the reservoir. Press the power button to turn Pico off.



Unscrew and remove the Inline Filter cap attached to the BLACK Ball Lock Connector hose. Remove the blue filter insert and rinse it thoroughly using tap water. Place it back in the Inline Filter and screw the filter cap back on, finger tight.

Thoroughly clean and rinse the Step Filter, lid, Brewing Keg, and black Keg Seal.

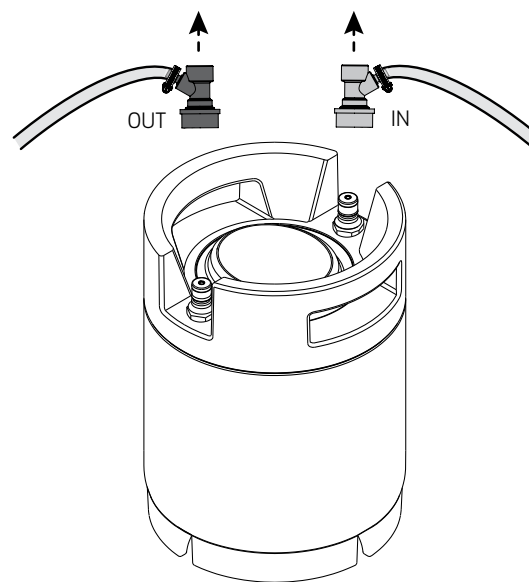

**Consuming raw or undercooked meats, poultry, seafood, shellfish or eggs may increase your risk of foodborne illness.**



# MANUAL GLOSSARY

**EVERYTHING  
YOU NEED TO  
IMPRESS  
YOUR FRIENDS  
AND BREW  
CORRECTLY.**

UNBOXING

SETUP

FIRST  
RINSE

LET'S  
BREW

AFTER  
BREWING

FERMENT  
YOUR BEER

DRY  
HOPPING

RACK &  
CARBONATE

SERVING

USAGE &  
CARE

SOUS VIDE

GLOSSARY

**ADJUNCT** A fermentable addition to the mash that includes sugars, syrups, and unmalted cereal grains such as corn, rice, oats that provide extra sugars in the wort.

**AERATE** Introducing oxygen into the wort to make sure yeast can reproduce abundantly.

**ALE** A generic term used for beers that are created using a top-fermenting yeast strain at a higher temperature than lager yeast strains.

**BACTERIA** Single-celled organisms that reproduce quickly in specific environments. Integral to specific beer styles, particularly sours, and considered an off-flavor and flaw in the majority of all other beer styles.

**CARBONATION** Carbon dioxide (CO<sub>2</sub>) is a naturally occurring by-product of fermentation. Keg Conditioning is natural carbonation created during fermentation when yeast metabolize sugars. Forced carbonation is the addition of CO<sub>2</sub> to the final beer.

**DOUGH IN** Part of the mash process where grains soak to activate and distribute temperature-specific enzymes.

**DRY HOP** The addition of hops after initial fermentation to increase hop aroma without increasing hop bitterness.



**FERMENTATION**

**ESTERS** Aromatic flavor compound created by yeast during fermentation. Esters contribute fruity aromas to beers.

**HOPS** Hops are the flower cones of a the hop plant, used to contribute bitterness, aroma, and anti-microbial qualities to beer. Commercially available in pellet, plugs, whole cone, or extracted forms.

**KRAUSEN** Thick, moussy foam on the top of fermenting wort that occurs during the beginning of fermentation.

**LAGER** A generic term used for beers that are created using a bottom-fermenting yeast strain at a lower temperature than ale yeast strains. Also a term for cold-storing a beer for an extended amount of time.

**MALT** Barley, or other grains, used during the mash and brewing process. Contributes a wide range of flavors from uncooked bread to roasted coffee, depending on its kiln or roasted level.

**MASH** The process of steeping milled grains in hot water in order to activate enzymes and extract sugars from the malt.

**PHENOLS** Chemical compounds derived from yeast activity during fermentation. Vary from spicy, peppery, smoky, medicinal, and many more.

**PITCH** The process of adding yeast to cooled wort to start fermentation.

**PRIMING** The act of adding a small amount of sugar to fermented beer in order to restart fermentation and create carbonation inside bottle or keg.

**PSI** Pounds per square inch.

**RACKING** The process of transferring beer from one keg to another.

**TRUB** A solid material composed of yeast, proteins, and hop particles that fall out of solution during brewing and fermentation

**WILD YEAST** Yeast that is naturally airborne and ubiquitous. Typically used in sours or wild ales, considered an off-flavor in a majority of other beer styles.

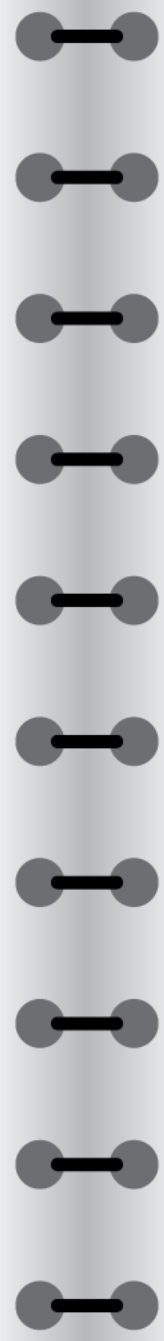

**WORT** Unfermented liquid containing sugars extracted from the malt grain during the mash process. Adding yeast to wort starts the fermentation process which transforms the wort into beer.

**YEAST** Single-celled fungus that breaks down sugars in the wort during fermentation into carbon dioxide, alcohol, and creates various phenols or esters.

**IMPERIAL AND METRIC CONVERSION TABLE**

IMPERIAL	METRIC
0.5 gallon	1.9 liters
1 gallon	3.8 liters
2.5 gallons	9.5 liters
3 gallons	11.4 liters
75-84 F	23.9-28.9 C
70-74 F	21.2-23.3 C
65-69 F	18.3-20.6 C







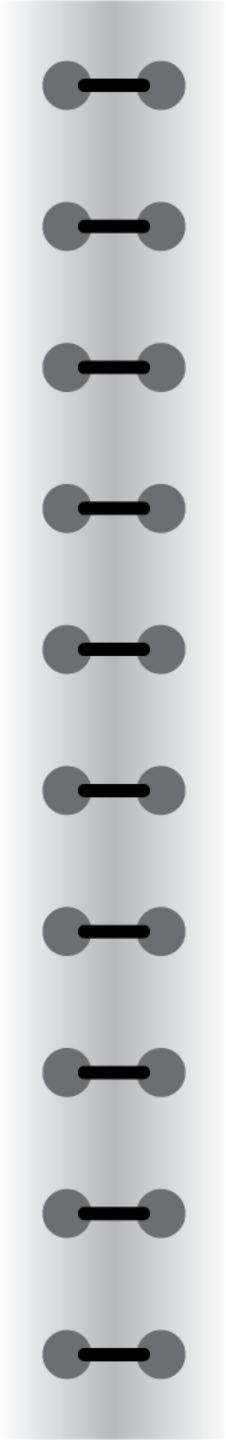

18-0126

Copyright 2017

[www.PicoBrew.com](http://www.PicoBrew.com)

# PICO INSTRUCTION MANUAL

