



Measurement data monitoring with testo Saveris Professional Edition

Instruction manual



1 Contents

1	Contents	3
2	Safety and the environment	7
2.1.	About this document.....	7
2.2.	Ensure safety.....	8
2.3.	Protecting the environment.....	8
3	Specifications	9
3.1.	Use	9
3.2.	System requirements.....	11
4	Product description	14
4.1.	Saveris base.....	14
4.2.	Saveris base GSM module (optional)	16
4.2.1.	Control keys	16
4.2.2.	Displays.....	17
4.3.	Saveris cockpit unit.....	23
4.3.1.	Control keys	24
4.3.2.	Displays.....	25
4.4.	Save radio probe	29
4.4.1.	Radio probe without display.....	29
4.4.2.	Radio probe with display.....	30
4.4.3.	Meaning of the LED displays at the probes.....	31
4.5.	Saveris Ethernet probes	32
4.6.	Saveris router	34
4.7.	Saveris converter.....	35
4.8.	Saveris extender.....	36
4.9.	Saveris analog coupler	37
4.10.	Network environment.....	37
5	First steps	38
5.1.	Flowchart.....	38
5.2.	Flow chart (Saveris mobile).....	40
5.3.	Inserting SIM card (optional).....	42
5.4.	Connecting the network cable to the Saveris base.....	43
5.5.	Connecting GSM antenna (optional)	44
5.6.	Connecting Saveris base with power supply	45
5.6.1.	Power supply via mains unit	45
5.6.2.	Power supply via plug-in/screw connection (optional).....	46
5.7.	Connecting USB cable (optional).....	47
5.8.	Inserting batteries in the probes	48
5.9.	Connecting radio probe	49

5.10.	Installing Saveris software	51
5.11.	Starting up hardware.....	52
5.12.	Disconnecting USB cable.....	56
5.13.	Starting Saveris software	56
5.14.	Expand measuring system.....	58
5.14.1.	Integrating a Saveris router (optional).....	58
5.14.1.1.	Connecting router with power supply (mains unit)	59
5.14.1.2.	Connecting router with power supply (AC/DC).....	60
5.14.1.3.	Connecting router	62
5.14.1.4.	Assigning probes	65
5.14.1.5.	Connecting routers in series	67
5.14.2.	Assigning an IP address to the Saveris base (optional)	71
5.14.3.	Integrating Saveris converter (optional)	72
5.14.4.	Integrating Saveris Ethernet probe (optional)	73
5.14.4.1.	Connecting the network cable.	74
5.14.4.2.	Connecting Ethernet probe with power supply (mains unit).....	75
5.14.4.3.	Connecting USB cable and installing driver (optional)	76
5.14.5.	Assigning an IP address to the Saveris base (optional)	77
5.14.5.1.	Assigning connection data	78
5.14.5.2.	Connecting Ethernet probe with the Saveris base	80
5.14.5.3.	Starting up Ethernet probes	81
5.14.6.	Integrating a Saveris extender.....	85
5.14.7.	Integrating a Saveris cockpit unit (optional)	87
5.14.7.1.	Registering a Saveris cockpit unit	87
5.14.7.2.	Fitting a Saveris cockpit unit in the driver's cab and connecting to a power supply	89
5.14.8.	Integrating Saveris analog coupler (optional).....	91
5.15.	Performing the test run	98
5.15.1.	Checking system availability.....	99
5.15.2.	Testing the system.....	99
5.16.	Mounting the hardware	101
5.16.1.	Mounting the Saveris base on the wall.....	101
5.16.2.	Setting up Saveris base with stand	103
5.16.3.	Mounting the probe on the wall	104
5.16.4.	Checking the measuring system again	106
6	Using the product	107
6.1.	User interface.....	107
6.2.	Menus and commands.....	109
6.2.1.	Start	109
6.2.2.	Edit.....	111
6.2.3.	Axes	115
6.2.4.	Template	115
6.2.5.	Service	116
6.2.6.	Selecting projects	116
6.2.7.	Style template	116
6.3.	Creating, editing and deleting zones.....	116
6.3.1.	Creating zones.....	117
6.3.2.	Changing zones.....	117
6.3.3.	Deleting zones	118



6.3.4.	Assigning zones	118
6.4.	Setting up tours	119
6.4.1.	Tour description	119
6.4.2.	Planning tours	120
6.4.3.	Defining tours	121
6.4.4.	Displaying tours	121
6.4.5.	Searching for tours	122
6.4.6.	Changing tours	123
6.5.	Configuring the alarms	123
6.5.1.	Setting up base alarms	124
6.5.1.1.	Setting up alarms	124
6.5.1.2.	Configuring scheduling	126
6.5.2.	Setting up alarm groups	127
6.5.2.1.	Components	127
6.5.2.2.	Channels	129
6.5.3.	Creating recipient	131
6.5.4.	Creating alarm rules	134
6.5.5.	Alarm overview	137
6.5.6.	Comments for acknowledging alarms	138
6.6.	Analyzing series of measurements	139
6.6.1.	Diagram view	139
6.6.1.1.	Enlarging the view	139
6.6.1.2.	Information on a reading (crosshairs)	140
6.6.1.3.	Showing regression curve	140
6.6.1.4.	Text field	140
6.6.1.5.	Characteristics of a curve	141
6.6.1.6.	Settings for the axes in the diagram	145
6.6.2.	Histogram view	148
6.6.3.	Monitor view	148
6.6.4.	Table view	149
6.6.4.1.	Marking readings	149
6.6.4.2.	Dropping the marking	150
6.6.4.3.	Inserting extreme values or mean in the table	150
6.6.4.4.	Compressing readings	150
6.6.4.5.	Dropping compression	151
6.6.4.6.	Determining largest reading	151
6.6.4.7.	Determining the smallest reading	151
6.6.4.8.	Add rows	151
6.6.4.9.	Compress	151
6.6.4.10.	Drop compression	151
6.7.	Analyzing alarms	152
6.7.1.	Checking alarms	152
6.7.2.	Acknowledging an alarm	152
6.8.	Creating evaluations	154
6.8.1.	Printing measurement data	155
6.8.2.	Archiving with automatic reports	155
6.9.	Checking the database capacity	156
6.10.	System settings	157
6.10.1.	General settings for the Saveris base	159
6.10.2.	Show operating data of the probes	160
6.10.3.	Settings for the radio probe	161

6.10.4.	Ethernet probes	163
6.10.5.	Analog coupler	165
6.10.6.	Saveris cockpit unit	166
6.11.	Report settings	167
7	Maintaining the product	170
7.1.	Maintenance	170
7.2.	Replacement of components	170
7.2.1.	Deleting components	171
7.2.2.	Adding new components	173
7.2.3.	Logging components back in	178
7.3.	Calibration and adjustment	180
7.3.1.	On-site calibration and adjustment	181
7.3.2.	External calibration and adjustment	181
7.4.	Saving data in the Saveris base	182
7.5.	Restarting the Saveris base	183
7.6.	Removing probe from wall bracket	184
7.7.	Changing batteries at probe	184
7.8.	Changing a battery	186
7.9.	Carrying out a software and firmware system update	189
7.9.1.	Carrying out a software update	189
	Uninstalling software	190
7.9.1.1.	Software installation	190
7.9.1.2.	Installing the server	190
7.9.2.	Carrying out a firmware system update	190
7.9.3.	Carrying out a Saveris cockpit unit firmware update	193
7.10.	Technical data	194
7.10.1.	Saveris base	194
7.10.2.	Saveris radio probe	195
7.10.3.	Saveris router	202
7.10.4.	Saveris Ethernet probes	203
7.10.5.	Saveris converter	209
7.10.6.	Saveris cockpit unit	210
7.10.7.	Saveris extender	211
7.10.8.	Saveris analog coupler	212
8	Tips and assistance	215
8.1.	Questions and answers	215
8.2.	Saveris base alarm messages	215
8.3.	Accessories and spare parts	217

2 Safety and the environment

2.1. About this document

Symbols and writing standards

Representation	Explanation
	Warning advice, risk level according to the signal word: Warning! Serious physical injury may occur. Caution! Slight physical injury or damage to the equipment may occur. > Implement the specified precautionary measures.
	Note: Basic or further information.
1. ... 2. ...	Action: more steps, the sequence must be followed.
> ...	Action: a step or an optional step.
- ...	Result of an action.
	Position numbers for the clarification of the relationship between text and picture.
Menu	Elements of the instrument, the instrument display or the program interface.
[OK]	Control keys of the instrument or buttons of the program interface.
... ...	Functions/paths within a menu.
“...”	Example entries

Use

- > Familiarity with a PC as well as the Microsoft® products, especially Microsoft® Office 2007, is assumed in this documentation.
- > Please read this documentation through carefully and familiarize yourself with the product before putting it to use. Pay particular attention to the safety instructions and warning advice in order to prevent injuries and damage to the products.

- > Keep this document to hand so that you can refer to it when necessary.
- > Hand this documentation on to any subsequent users of the product.

2.2. Ensure safety

- > Never use the Saveris probes to measure on or near live parts.
- > Carry out only the maintenance and repair work on the components of the testo Saveris system that is described in the documentation. Follow the prescribed steps exactly. Use only original spare parts from Testo.
- > Only operate the product properly, for its intended purpose and within the parameters specified in the technical data. Do not use any force.
- > The power supply output for the Saveris probes, routers, converters, cockpit unit, extender and the Saveris base is restricted in accordance with EN 60950-1:2001. A manipulation of the power supply is not allowed in terms of the radio authorisation.
- > The radio module is installed in the Saveris components so that the limit values for air and creepage distances are adhered to in accordance with the standards. Changing the internal design of the components is not allowed.
- > When selecting the mounting location, ensure that the permissible ambient and storage temperatures are adhered to (see technical data).



At temperatures below 5 °C the rechargeable batteries will not charge, within this temperature range secure system operation is only possible to a limited extent.

2.3. Protecting the environment

- > Dispose of faulty rechargeable batteries/spent batteries in accordance with the valid legal specifications.
- > At the end of its useful life, send the product to the separate collection for electric and electronic devices (observe local regulations) or return the product to Testo for disposal.

3 Specifications

3.1. Use

Areas of application

The testo Saveris measurement system can be used anywhere where temperature and humidity-sensitive products are produced, stored or transported, for example in the food industry (cold rooms, deep freeze rooms and refrigerated/deep freeze transporters), in smaller companies in food production, such as bakeries and butchers, or in the pharmaceuticals industry (temperature-controlled cabinets, storage and transportation of drugs).

But the measurement system can also be used in other industries for monitoring building air conditioning, as well as for quality assurance in store rooms for products in every phase of production.

-
- i** The testo Saveris measurement system is only used to monitor measured values, not to control and regulate them.
 - i** The base with the SMS module may not be operated in environments where, for example, the use of a mobile phone is prohibited.
 - i** Mobile monitoring is only available to countries with appropriate radio authorisation of 868 MHz.
-

How it works

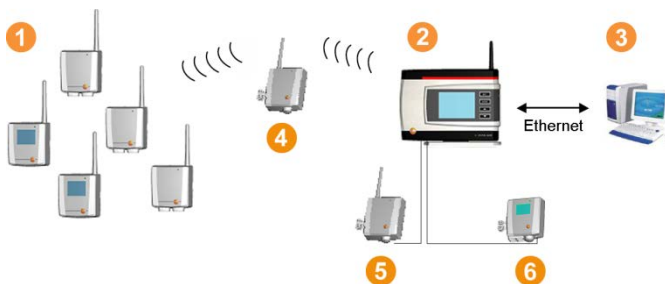

With the measurement system, ambient or process data for temperature and humidity in sealed rooms and/or during transportation is measured and recorded using probes **1**. These measured values are transmitted by radio to the Saveris base **2** and saved. A router **4** can be used to optimize the radio signal in

the event of difficult structural conditions. The data is then called up from a computer ③ by the Saveris base and saved to a database. Very long distances can be bridged using a converter ⑤, which converts the radio signals of the probe or router and then transmits this measurement data to the base via an Ethernet cable. The so-called Ethernet probes ⑥ can also be connected to the base using an Ethernet cable.

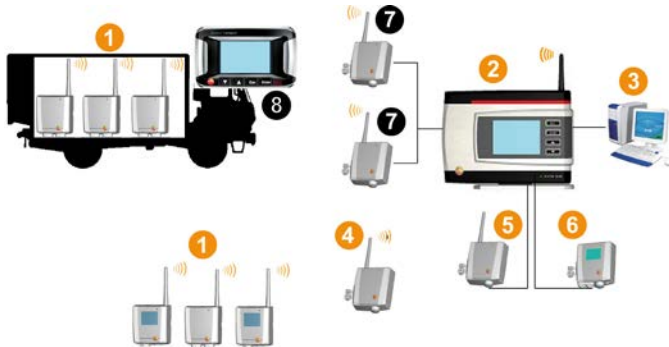

The temperature and/or air humidity during the transportation of sensitive goods are also monitored by radio probes ①. If the transportation container (e.g. HGV) returns to the base, the measured values are transferred to the extender ⑦ or the Saveris base ② as soon as there is an adequate radio link. The extender converts the radio signals of the probes and then forwards the measured values via Ethernet cable to the Saveris base ②. For direct monitoring of measured values, a Saveris cockpit unit can be used in the HGV ⑧.

If radio probes are registered in mobile zones, all these probes are in one radio cell on the same channel. The Saveris extenders work as external distributed antennas of the Saveris base. All of these radio probes are registered on the Saveris base.

In contrast, Saveris converters each span separate radio cells with different radio channels (among one another but also to the Saveris base). The probes are directly and uniquely assigned to the converter.

With the testo Saveris software, you always have an overview of the development of the measured values in the individual areas.

The specific advantages of Saveris with regard to data security and availability come about through the saving of configuration data to distributed locations in the system (e.g. in the probe, in the base, in the PC database). Synchronisation is carried out at regular intervals, during radio transmission every 15 min. Depending on the system architecture (cascaded routers) and a running process (e.g. firmware update, radio probe over air), the transfer cycle is also the

determining time factor for synchronisation. This is noticeable when updating changed alarm conditions or also when cancelling alarms. If synchronisation is not completed, this is indicated by a * after the system component in the **System** view.



If you want to mix existing components (order number: 0572.x1xx) with newly purchased components (order number 0572.x2xx) in a Saveris system, please first check compatibility.

If you have any queries or problems, please contact Testo Customer Service. Contact data see back of this document or website www.testo.com/service-contact.

Exclusion of liability

The testo Saveris system was developed to consolidate a large amount of measurement data from spatially separated probes in the Saveris software, document it without interruption and issue alarms in the event of irregularities.

The testo Saveris system is not designed to undertake control and regulation tasks according to the regulations. Particularly the alarms are not to be perceived as so-called critical alarms with which the endangerment of life or limb or damage to equipment can be averted.

Liability on the part of Testo AG for damages from this type of application is excluded.

3.2. System requirements

Operating system

The software will run on the following operating systems:

- Windows® Vista SP2 64-bit/ 32-bit or later
- Windows® 7 SP1 64-bit/ 32-bit or later
- Windows® 8 64-bit/ 32-bit
- Windows® 8.1 64-bit/ 32-bit
- Windows® Server 2008 SP2 64-bit
- Windows® Server 2008 R2 64-bit
- Windows® Server 2012 64-bit
- Windows® Server 2012 R2 64-bit

Computer

The computer must meet the requirements of the corresponding operating system. The following requirements must additionally be fulfilled:

- 4.5 GB unused hard drive capacity with maximum size of the database
- USB 2.0 interface
- Microsoft® Internet Explorer 9.0 or later
- Microsoft® Windows® Installer 4.5 or later
- Microsoft® .NET Framework 4.0 SP1 or later
- MDAC 2.8 SP1 or later
- Microsoft® Outlook® (only for MAPI installation)

i The computer's processor, hard disk and interfaces must be configured for continuous operation in order to ensure smooth automatic operation. If necessary, check your computer's energy-saving options.

i If Windows® Installer 4.5, MDAC 2.8 SP1 and .NET Framework 4.0 SP1 are not present on the computer, they will be installed with the Saveris software. Restart after installation.

i Date and time settings will be automatically accepted by the PC. The administrator must make sure that the system time is regularly compared with a reliable time source and adjusted if necessary, to ensure authenticity of the measurement data.

Database

- SQL Server® 2012 R2 Express is supplied.
- The Microsoft® versions SQL Server 2008, 2012, 2014 and Terminal Server are supported.

i In client-server operation, we recommend a network with AD and DNS (Domain Name System) to enable online updating using MSMQ (Microsoft® Message Queuing).

i Testo Saveris works with an SQL database. If a SQL database is already on the installation PC, a second instance can be created for Testo Saveris.

i When access to the Saveris instance of the Microsoft® SQL database is to be performed via a firewall, a port must be released in the firewall for this. Note the safety instructions from Microsoft®.

i The use of virus scanners can noticeably reduce system performance, depending on the configuration.

i When installing the software on virtual operating systems, the available system resources must be checked and, if necessary, improved. In combination with virtual systems, a USB connection works unreliably, which is why we recommend connecting the base via Ethernet.

Rechargeable battery

The battery in the Saveris base, the Ethernet probes and the analog coupler is a wearing part, which has to be replaced after approx. 2 years. If a battery is faulty, it is not possible to guarantee full operability of the GSM module. In the event of a power failure, data loss cannot be ruled out for all components. When a component's battery is no longer fully functional, it triggers a **Defective battery** system alarm.

The battery (article no. 0515 0021) should then be replaced immediately to ensure full functionality and data security.

4 Product description

i As declared in the declaration of conformity, this product complies with Directive 2004/108/EC.

4.1. Saveris base

Front

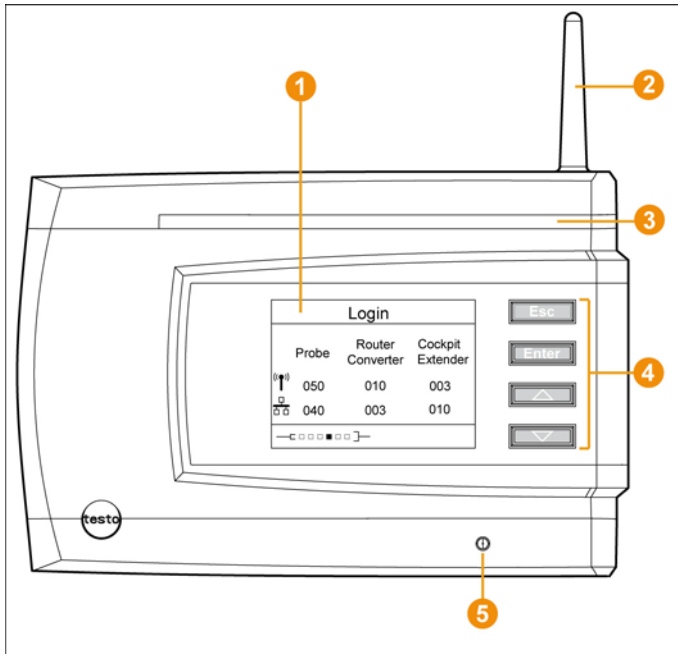

- ① Display for the visualization of the alarms and user guidance.
- ② Antenna.
- ③ Warning LED
- ④ Keypad for operation of the Saveris base.
- ⑤ LED for status display.

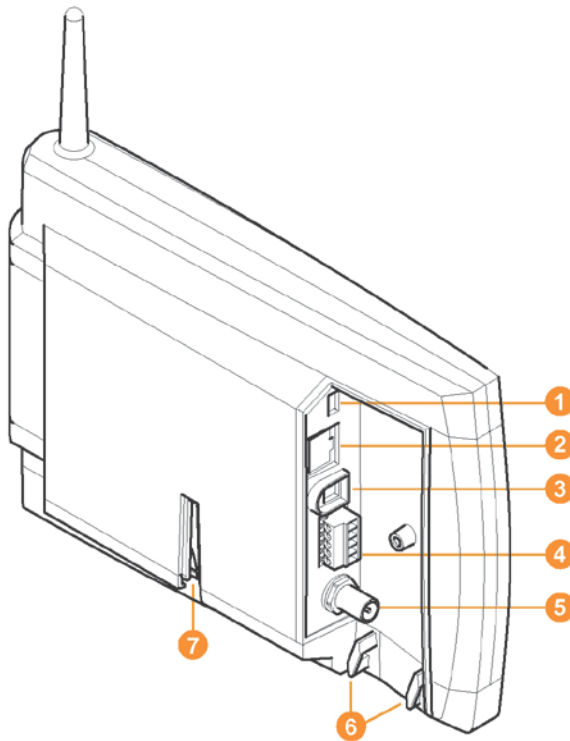
Rear

- 1 USB cable connection.
- 2 Network cable connection.
- 3 Connection of power supply via mains plug.
- 4 Connection of power supply via 24 V AC/DC and alarm relay.

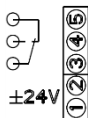

- 5 Connection for external GSM antenna (only in combination with GSM module).
- 6 Eyelets for strain relief.
- 7 Guide for stand or wall bracket.

4.2. Saveris base GSM module (optional)

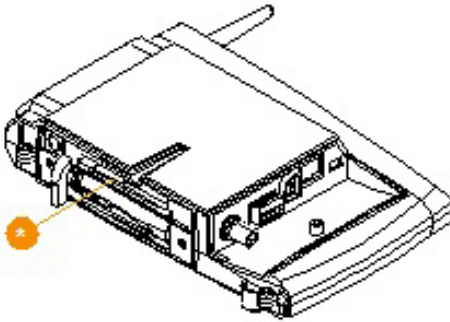

✱ Insertion slot for the SIM card.

4.2.1. Control keys

Key	Explanation
[Esc]	Switches from the Login menu to the Info System menu. In the Info Base menu, press [Esc] briefly 2x: shuts down the Saveris base Press and hold [Esc]: starts up the Saveris base
[Enter]	In the Info System menu starts up the login status for the probe.
[▲], [▼]	Navigation buttons for changing the menus.

4.2.2. Displays

Menu **Info Base**

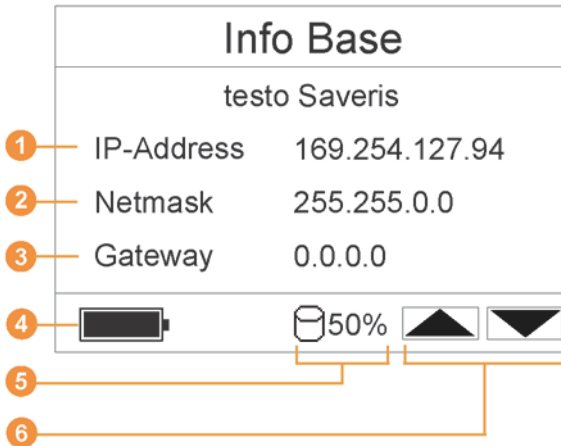

- 1 IP address of the Saveris base.
The IP address is the unique identification number of the Saveris base within the network.
- 2 Netmask saved in the Saveris base.
The netmask is the basic address of the network in which the Saveris base is integrated.
- 3 Address of the gateway saved in the Saveris base.
A gateway is a transfer point between networks that work with different protocols or data formats. A "translation" into the respective other protocol or data format is then performed by the gateway.
- 4 Fill level of the internal rechargeable battery in the event of a power failure. The display is only shown when there is an interrupted power supply.
- 5 Saveris base memory fill level.
- 6 Keys that are assigned functions in this menu.

Menu **Info alarm**

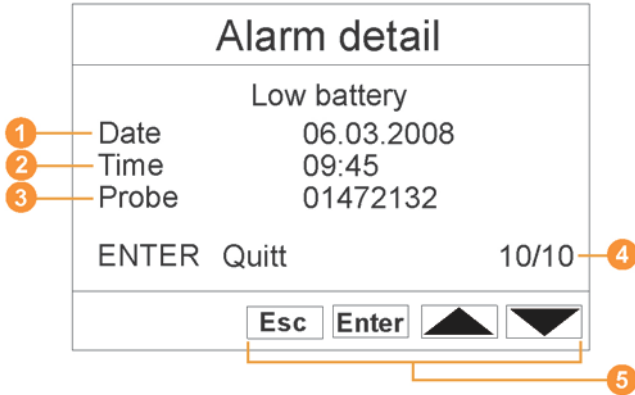

- 1 Number of newly triggered alarms.
- 2 Keys that are assigned functions in this menu.

i New alarms have to be checked and acknowledged at regular intervals. A large number (>100) of unacknowledged alarms will impair the system performance. The system automatically acknowledges unacknowledged alarms once these number 200 or more.

Menu **Alarm detail**

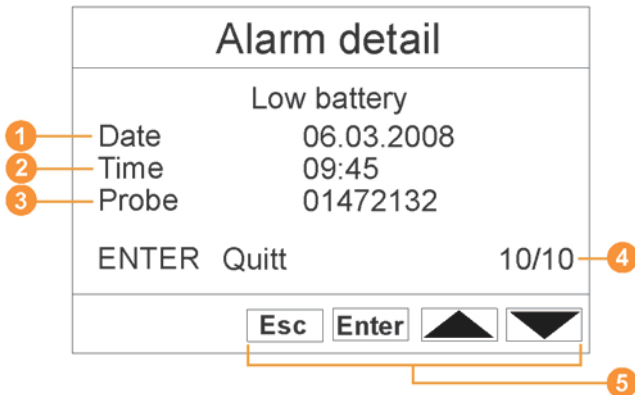

- 1 Date on which the alarm was triggered.
- 2 Time at which the alarm was triggered.
- 3 Probe for which the alarm was triggered.
- 4 Alarm number and total number of alarms.
- 5 Keys that are assigned functions in this menu.

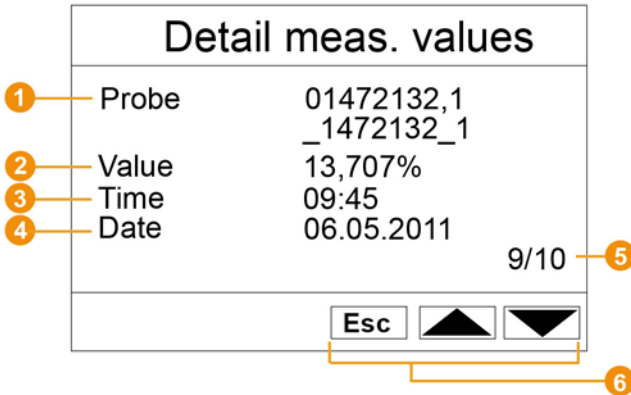
Menu **Detail meas. values**

- ① Probe and channel, if present, for which the measured value was transferred.
- ② Measured value with relevant unit.
- ③ Time at which the measured value was transferred.
- ④ Date on which the measured value was transferred.
- ⑤ Measured value number and total number of measured values.
- ⑥ Keys that are assigned functions in this menu.

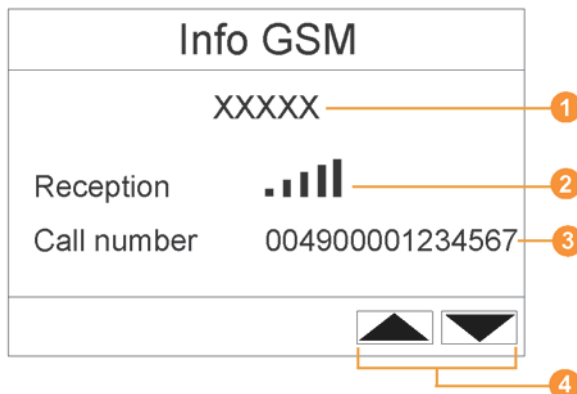
Menu **Info GSM**

- ① Name of network operator.
- ② Indication of reception quality.
- ③ Telephone number saved on the SIM card.
- ④ Keys that are assigned functions in this menu.

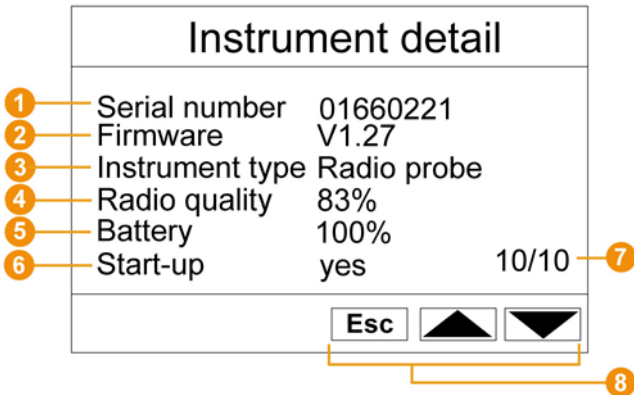

- 5 Version number of the internal GSM module.

Menu **Instrument detail**



- 1 Serial number of the successful device.
- 2 Firmware status of the successful device.
- 3 Model designation of the successful device.
- 4 Radio quality of the successful device (does not apply to Ethernet probes and Saveris extender).
- 5 Battery status of the device (does not apply to Ethernet probes, Saveris extender and Saveris cockpit unit).
- 6 Startup indicates whether the device has been configured by the startup wizard.
- 7 Number of successful devices.
- 8 Keys that are assigned functions in this menu.



Menu **Info System**

Info System			
	Probe	Router Converter	Cockpit Extender
	050 1	010 3	003 5
	040 2	003 4	010 6
<input type="button" value="Enter"/> <input type="button" value="▲"/> <input type="button" value="▼"/>			

7

- 1** Number of successful radio probes.
- 2** Number of successful Ethernet probes.
- 3** Number of successful routers.
- 4** Number of successful converters.
- 5** Number of successful Saveris cockpit units.
- 6** Number of successful Saveris extenders.
- 7** Keys that are assigned functions in this menu.

Menu **Login** 1/2

Login			
	Probe	Router Converter	Cockpit Extender
	050	010	003
	040	003	010
* 			

- *** Status display when logging in probes.

Menu **Login** 2/2

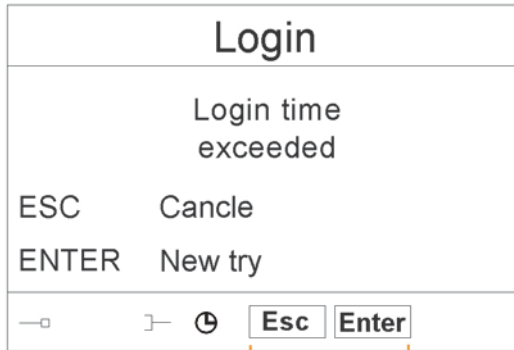

- ✱ Keys that are assigned functions in this menu.

i This display is shown if no login signal was received from a probe within approx. 30 seconds.

4.3. Saveris cockpit unit¹

Front

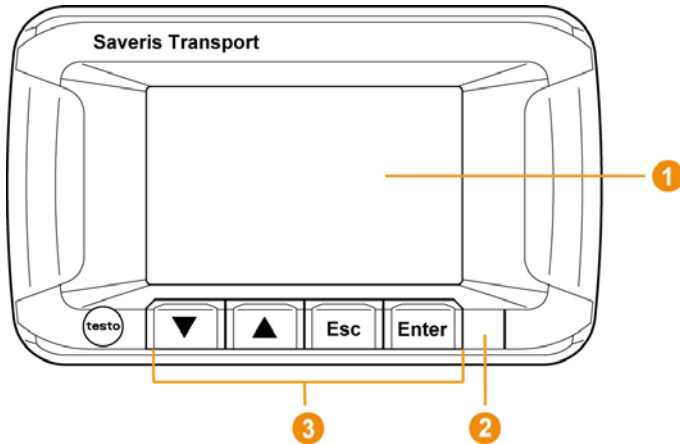

- ① Display for the visualisation of the alarms and user guidance
- ② Warning LED and IR interface
- ③ Key pad for operating the Saveris cockpit unit

Back

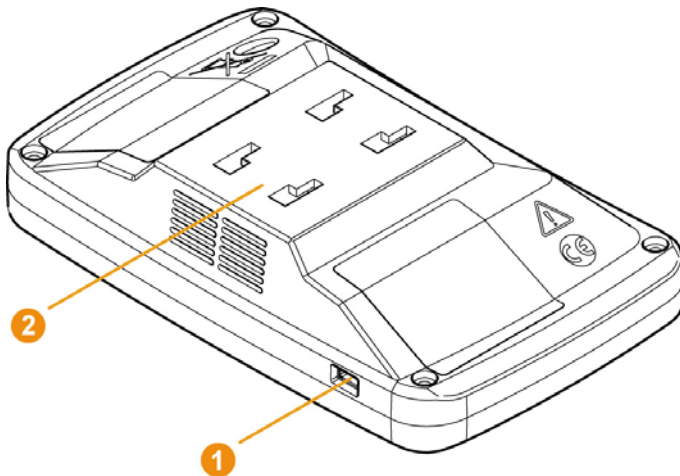

¹ This component is only permitted for mobile monitoring in countries with a radio frequency of 868 MHz.

- 1 Mini USB cable connection
- 2 Guide for mount

i Before changing the Saveris cockpit unit battery, please contact Testo Customer Service. You can find contact details on the back of this document or at www.testo.com/service-contact



4.3.1. Control keys

Key	Explanation
[Enter]	<ul style="list-style-type: none"> • Hold down [Enter] for 3 sec: Switch on the Saveris cockpit unit. • Starts the login status for the Saveris cockpit unit in the Login menu. • Switch to the next menu level down. • Confirm selected functions.
[Esc]	<ul style="list-style-type: none"> • Saveris cockpit unit is not registered on the Saveris base: In the Select language menu, press [Esc] briefly once. Shut down the Saveris cockpit unit. • Switch to the next menu level up. • Saveris cockpit unit is registered on the Saveris base: Hold down [Esc] for 3 sec: Shut down the Saveris cockpit unit. <hr/> <p>i While tours are running, the Saveris cockpit unit cannot be switched off.</p>
[▲], [▼]	Navigation keys to switch the menu or to select an option.

4.3.2. Displays

Icons

The following icons are displayed at the top right of all views

Feature	Values
	Tour started
	Data transfer is running between the following components: <ul style="list-style-type: none"> Saveris cockpit unit and Saveris extender/Saveris base Radio probes in the currently selected mobile zone and Saveris extender/Saveris base
!	Feedback informing the driver that a probe of the selected tour contains measurement data that have not yet been transferred to the Saveris base. The symbol only appears after a second measuring cycle or 30 minutes.

Menu **Device settings**

Sub-menus:

- Day/night settings
- Lighting
- Measured value display settings
- Factory reset

Menu **Alarms**

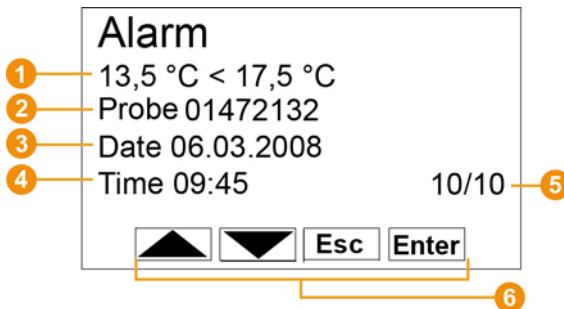

- 1 Description of why an alarm has been triggered.
- 2 Channel for which the alarm was triggered.
- 3 Date on which the alarm was triggered.
- 4 Time at which the alarm was triggered.
- 5 Alarm number and total number of alarms.
- 6 Keys that are assigned functions in this menu.

Menu Measured values

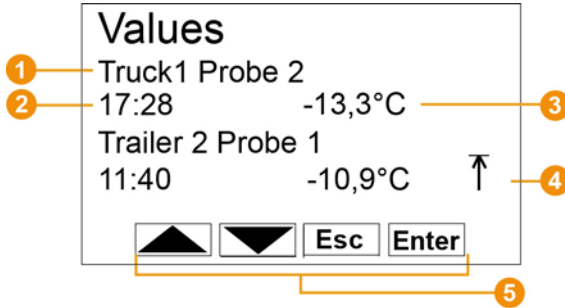

- 1 Probe and associated mobile zone for which the measured value was transferred.
- 2 Time at which the measured value was transferred / date on which the measured value was transferred (shown alternately in this line).
- 3 Measured value with relevant unit.
- 4 Indication of when limit values are not reached
- 5 Keys that are assigned functions in this menu.

Menu min/max

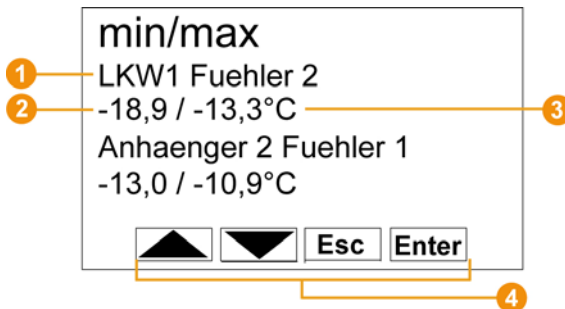

- 1 Probe and associated mobile zone for which the measured value was transferred.
- 2 Min. measured value with relevant unit.
- 3 Max. measured value with relevant unit.
- 4 Keys that are assigned functions in this menu.

Menu **Tour settings**

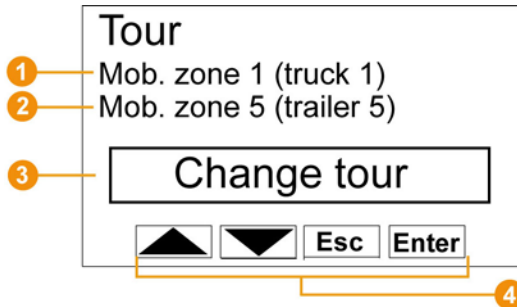

- 1 Selection of the first mobile zone (with [▲], [▼]).
- 2 Selection of the second mobile zone (with [▲], [▼]).
- 3 Selection of the action: Change tour, Start tour, Stop tour (with [▲], [▼]).
- 4 Keys that are assigned functions in this menu.

Menu **Print**

i The cockpit unit power supply should not be interrupted during the printing process.

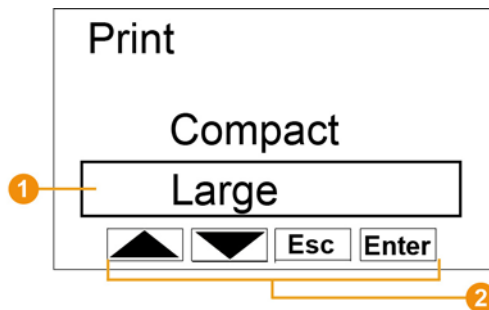

- 1 Selection of the output type.
- 2 Keys that are assigned functions in this menu.



The print data can be sent via infrared to the Testo printer 0554 0549.

Menu **Login** 1/2

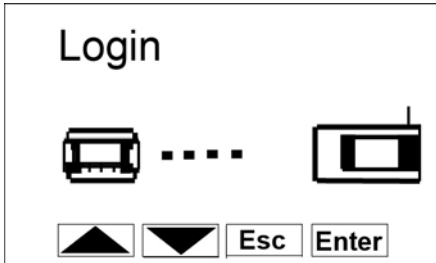

- ★ Status display when the Saveris cockpit unit registers on the base.

Menu **Login** 2/2

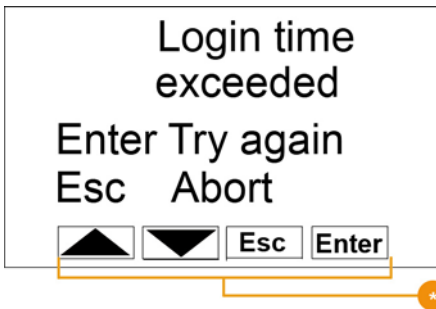

- ★ Keys that are assigned functions in this menu.



This display appears when the Saveris cockpit unit was unable to register on the Saveris base within approx. 30 seconds.

4.4. Save radio probe

4.4.1. Radio probe without display

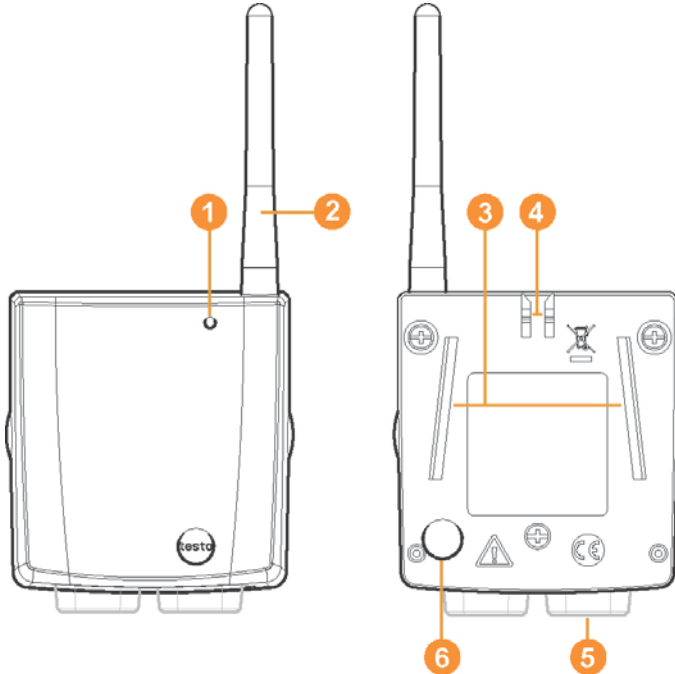

- 1 LED for status display.
- 2 Antenna for radio transmission of measurement data to the Saveris base.
- 3 Guide rails for the wall bracket.
- 4 Catch for the wall bracket.
- 5 Ports, depending on type.
- 6 Connect button for connecting the probe to the Saveris base and for a status request during operation.

4.4.2. Radio probe with display

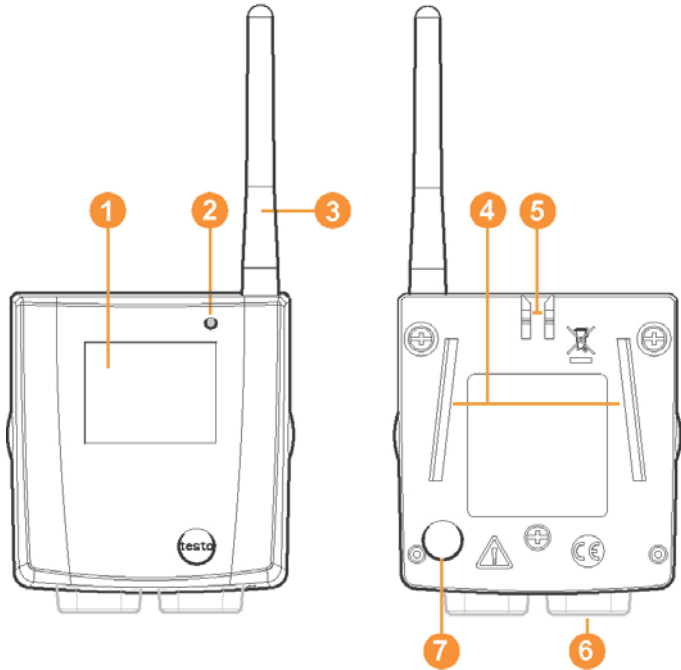

- ① Display for showing reading, battery and connection status as well as the field strength of the radio link.
- ② LED for status display.
- ③ Antenna for radio transmission of measurement data to the Saveris base.
- ④ Guide rails for the wall bracket.
- ⑤ Catch for the wall bracket.
- ⑥ Ports, depending on type.
- ⑦ Connect button for connecting the probe to the Saveris base and for a status request during operation.

Displays

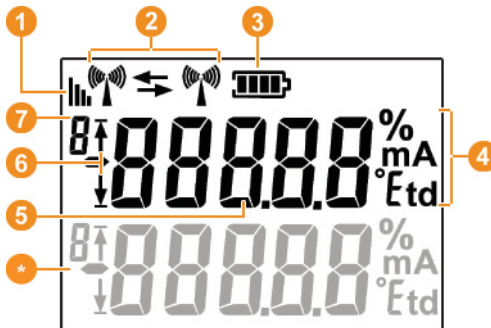

- 1 Quality of the radio link.
- 2 Indicator as to whether a communication with the Saveris base or a router or converter is performed.
- 3 Battery status.
- 4 Unit of the reading:
 - % for humidity measurement
 - mA for current measurement
 - °Ctd or °Ftd for dewpoint measurement.
- 5 Reading.
- 6 Indicator as to whether the reading has exceeded the upper (↑) limit value or undershot the lower (↓) limit value.
- 7 Number of the channel.
- * Display for a second sensor in the probe.

4.4.3. Meaning of the LED displays at the probes

Connecting to the Saveris base

Hold the connect button on the rear of the probe until the LED begins to flash orange.

Representation	Explanation
Flashing orange	An attempt to establish the connection to the Saveris base.
Lit up green	The connection to the Saveris base was performed successfully.
Lit up red	The connection to the Saveris base failed.

Status displays during operation

Briefly press the connect button on the rear of the probe once and the LED shows the status of the connection to the Saveris base.

Representation	Explanation
Flashing 3 x green	A very good connection to the Saveris base exists.
Flashing 2 x green	A good connection to the Saveris base exists.
Flashing 1 x green	A borderline connection to the Saveris base exists.
Flashing 3 x red	No connection to the Saveris base exists.

4.5. Saveris Ethernet probes

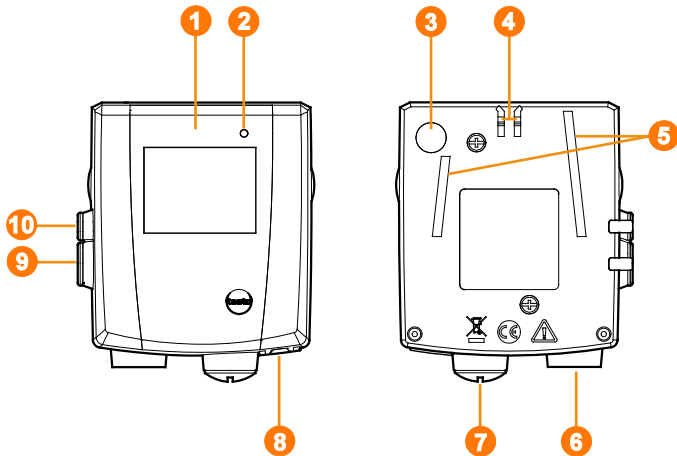

- 1 Display for showing the reading and transmission information.
- 2 LED for status display.
- 3 Connect button.
- 4 Catch for the wall bracket.
- 5 Guide rails for the wall bracket.
- 6 Input for external probes.
- 7 Input for external 24 V AC/DC power supply.
M1.6 x 1.5 cable coupling

- 8 Input for Ethernet interface.
- 9 Input for service interface.
- 10 Input for power supply via mains unit.

Displays

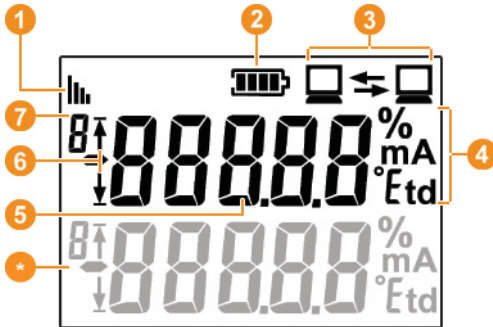

- 1 Quality of the connection.
- 2 Battery status.
- 3 Indicator as to whether a communication with the Saveris base is performed.
- 4 Unit of the reading:
 - % for humidity measurement
 - mA for current measurement
 - °Ctd or °Ftd for dewpoint measurement.
- 5 Reading.
- 6 Indicator as to whether the reading has exceeded the upper (↑) limit value or undershot the lower (↓) limit value.
- 7 Number of the channel.
- * Display for a second sensor in the probe.

4.6. Saveris router

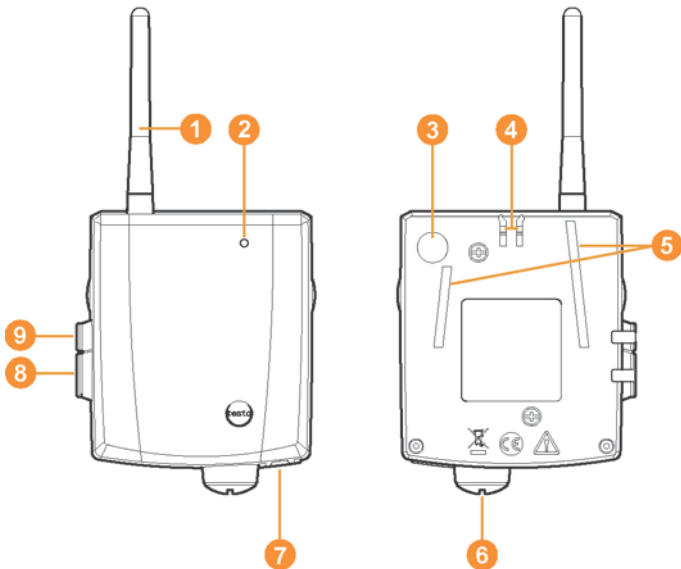

- ① Antenna for the radio transmission of the measurement data
- ② LED for status display
- ③ Connect button for connecting the router to the Saveris base and for a status request during operation
- ④ Catch for the wall bracket
- ⑤ Guide rails for the wall bracket
- ⑥ Input for external 24 V AC/DC power supply. M1.6 x 1.5 cable coupling
- ⑦ Input for service interface
- ⑧ Input for power supply via mains unit

4.7. Saveris converter

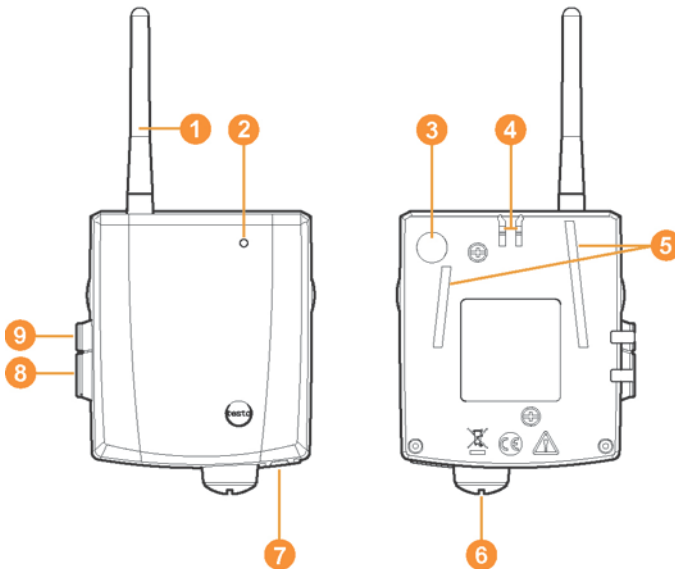

- 1 Antenna for receiving the measurement data.
- 2 LED for status display.
- 3 Connect button for connecting the converter to the Saveris base and for a status request during operation.
- 4 Catch for the wall bracket.
- 5 Guide rails for the wall bracket.
- 6 Input for external 24 V AC/DC power supply.
M1.6 x 1.5 cable coupling
- 7 Input for connecting the network cable (optional power supply via PoE).
- 8 Input for service interface.
- 9 Input for power supply via mains unit.

4.8. Saveris extender²

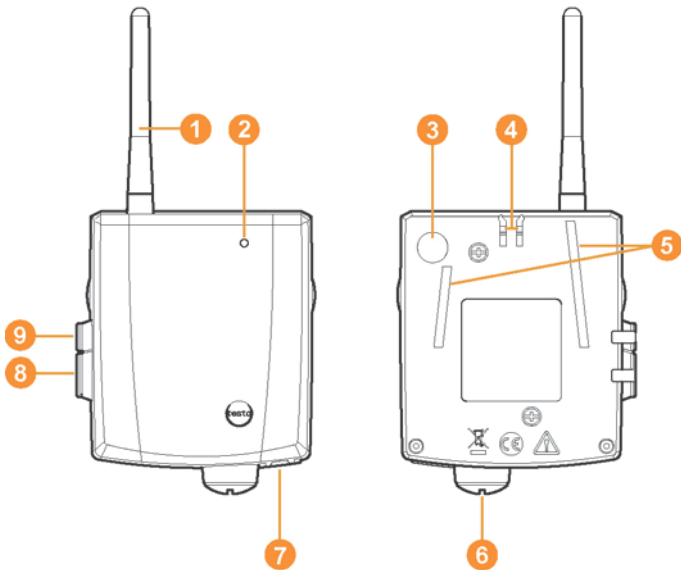

- ① Antenna for receiving the measurement data.
- ② LED for status display.
- ③ Connect key to query the status during operation.
- ④ Catch for the wall mount.
- ⑤ Guide rails for the wall mount.
- ⑥ Input for external 24 V AC/DC power supply, M1.6 x 1.5 cable coupling
- ⑦ Input for connecting the network cable (optional power supply via PoE).
- ⑧ Input for service interface.
- ⑨ Input for power supply via mains unit.

² This component is only permitted for mobile monitoring in countries with a radio frequency of 868 MHz. Saveris extender cannot be operated via VPN.

4.9. Saveris analog coupler

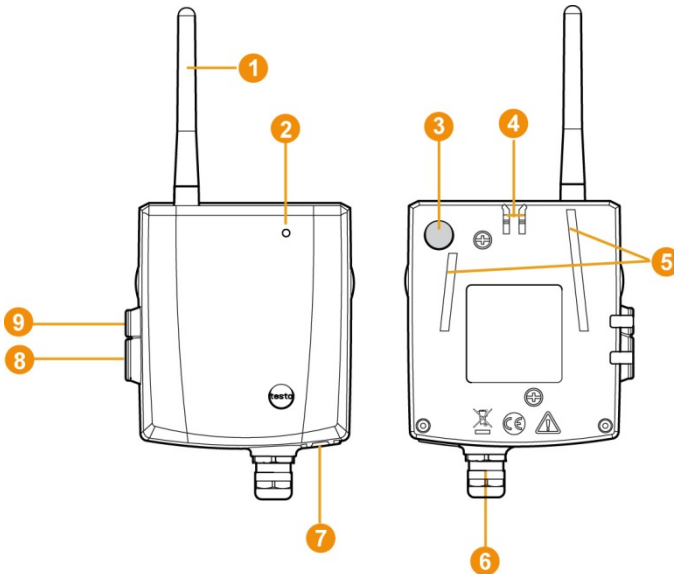

- ❶ Only with radio analog coupler U1: Antenna for sending the measurement data.
- ❷ LED for status display.
- ❸ Connect button for connecting the analog coupler to the Saveris base and for a status request during operation.
- ❹ Catch for the wall bracket.
- ❺ Guide rails for the wall bracket.
- ❻ Cable coupling M16 x 1.5 for connecting to the transmitter.
- ❼ Only with Ethernet analog coupler U1E: Input for connecting the network cable.
- ❽ Input for service interface.
- ❾ Input for power supply via mains unit.

4.10. Network environment

The testo Saveris software is installed as a client-server installation. In the process, the database and the Saveris Professional Client are installed on a server computer, and furthermore the Client and Viewer program components can be installed on additional client computers.

5 First steps

5.1. Flowchart

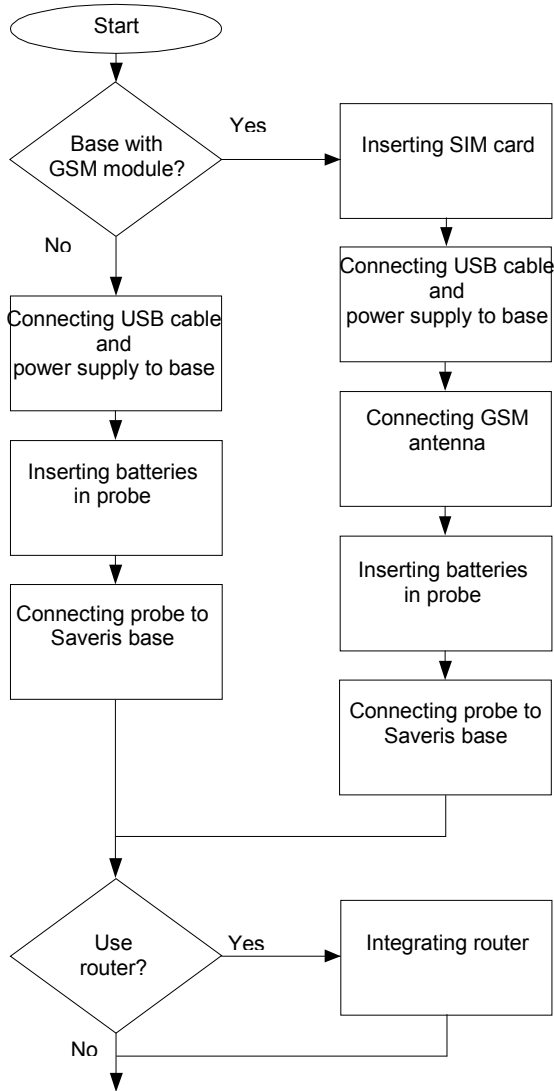

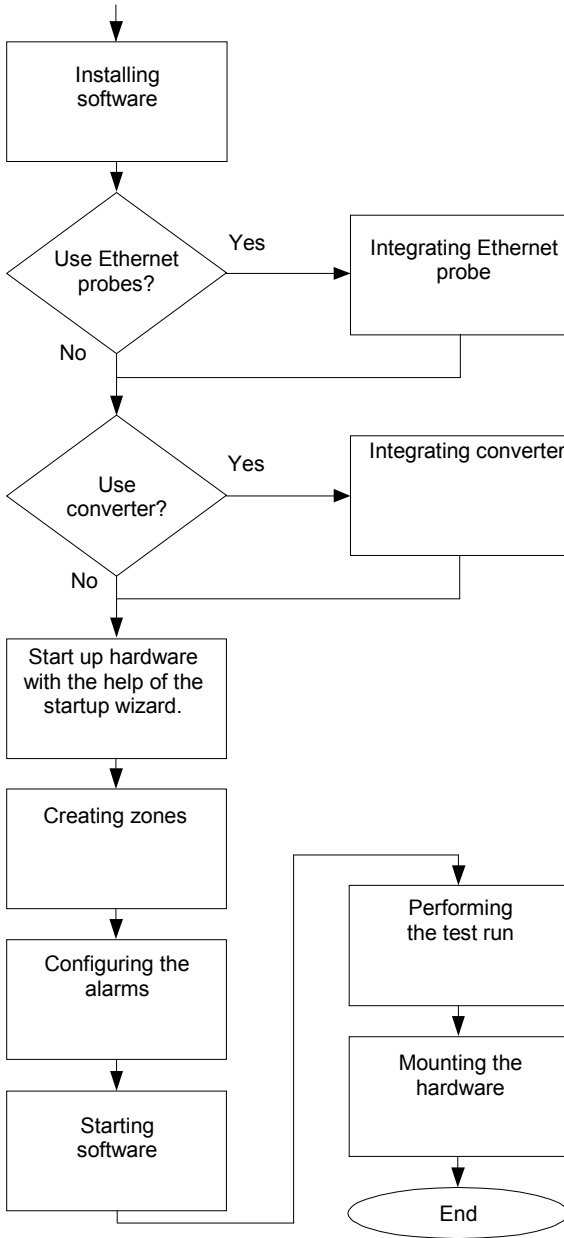

5.2. Flow chart (Saveris mobile)

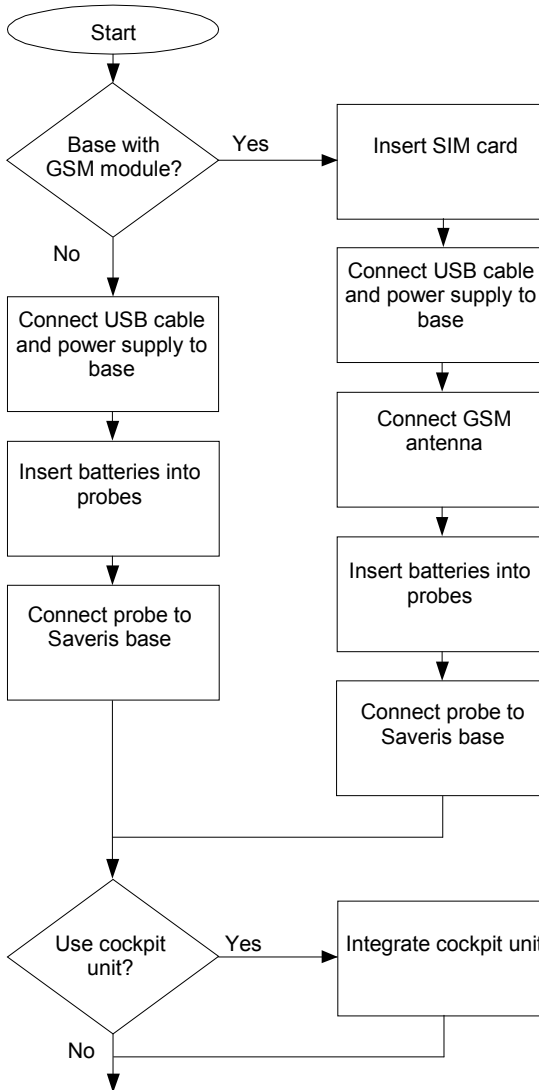

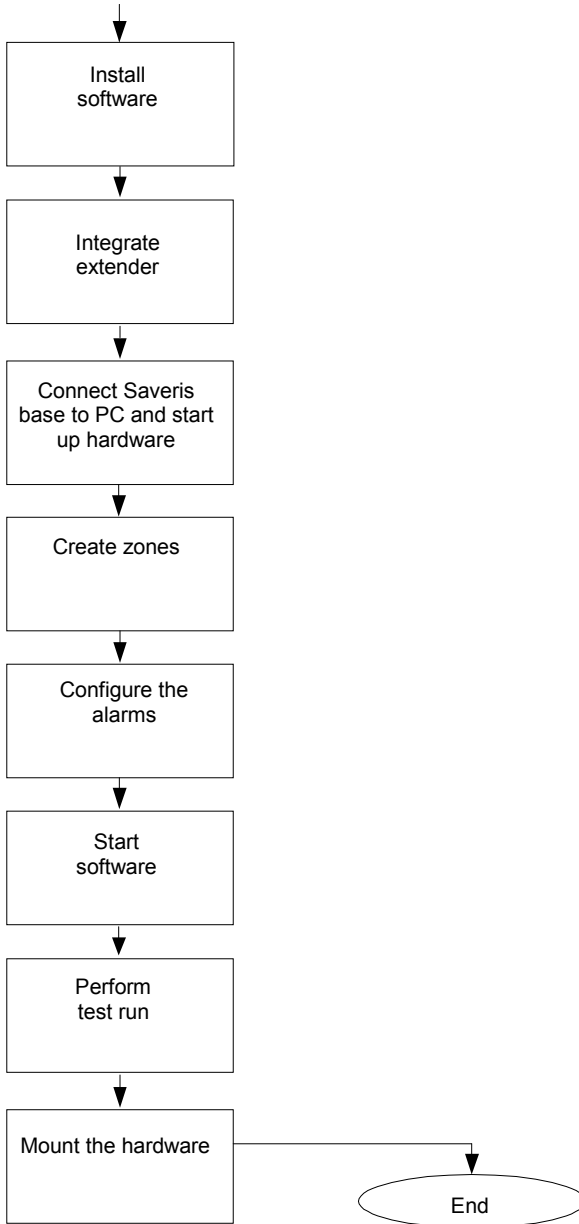

5.3. Inserting SIM card (optional)

With a Saveris base with integrated GSM module, you must insert the SIM card.

i The SIM card for sending SMS messages is not included in the delivery and must be purchased separately from a mobile phone provider. It is recommended that you use a contract card instead of a so-called prepaid card, as no alarm messages can be sent if you use up your credit.

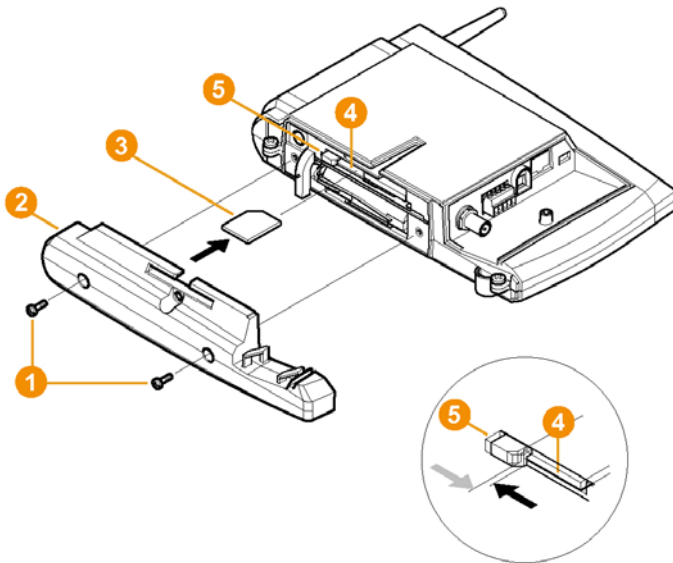

1. Switch off Saveris base (with **Info Base** view selected, briefly press **[ESC]** twice).
2. Loosen screw connection **1** and remove base plate **2** from the Saveris base.
3. Insert SIM card **3** in the card slot **4** as shown.

i When inserting, the SIM card **3** pushes the catch **5** to the side. If the card is inserted, a spring pushes the catch back and the SIM card is thus secured in the card slot.

4. Place the base plate on the base and screw it down.

5.4. Connecting the network cable to the Saveris base

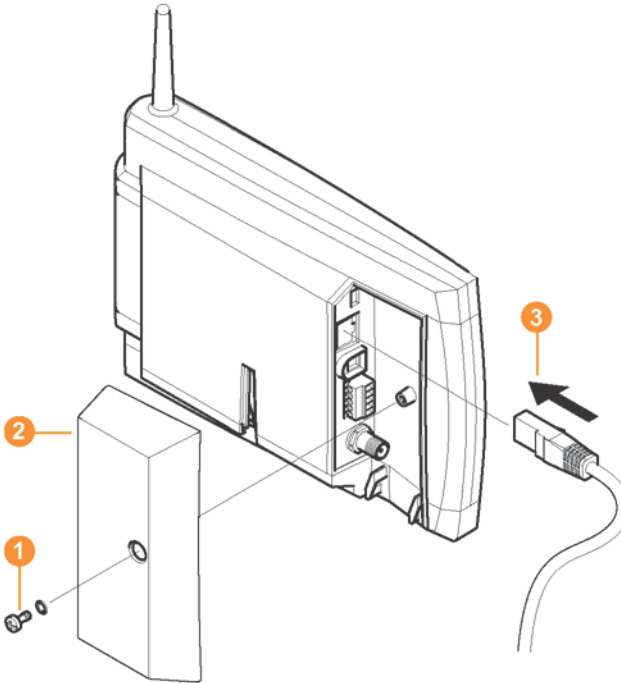

1. Loosen and remove **1** screw connection.
2. Remove cover **2** from Saveris Base.
3. Plug the network cable **3** into the Saveris base.
4. Connect the network cable **3** to the Ethernet.

5.5. Connecting GSM antenna (optional)

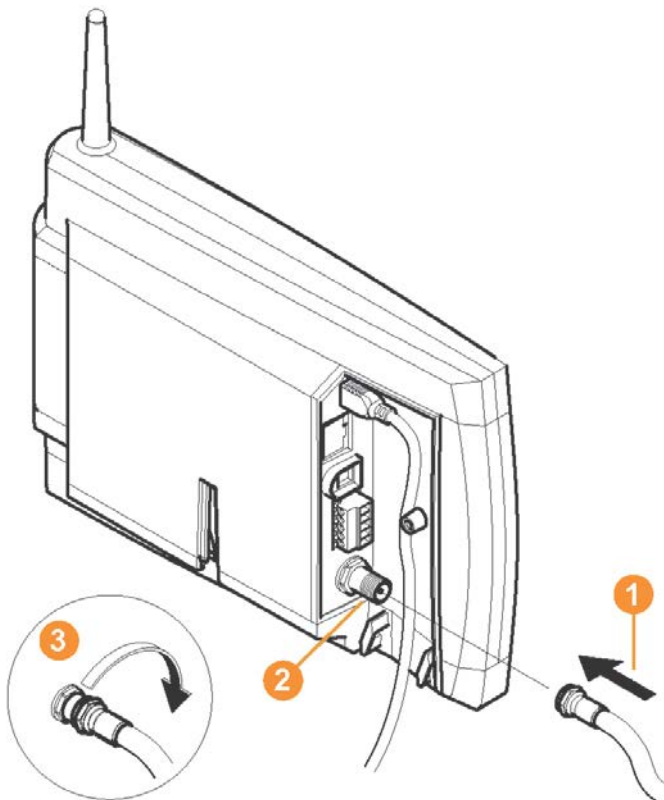

- > Place antenna cable **1** on the coaxial connection **2** and screw on **3**.

5.6. Connecting Saveris base with power supply

You can connect the Saveris base to the power supply via the included mains unit or via the 24 V AC/DC plug-in/screw terminal.

5.6.1. Power supply via mains unit

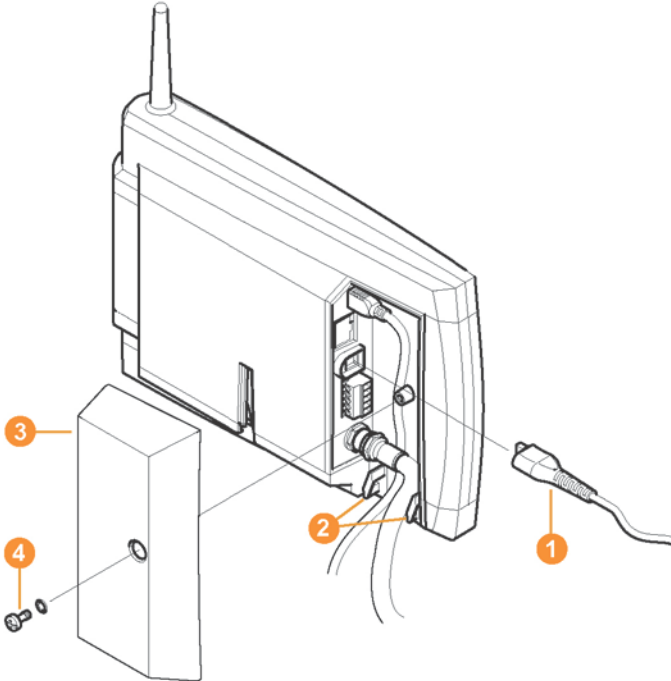

1. Connect mains cable **1** to the Saveris base.
2. Ensure that cabling cannot be pulled out using a cable tie at the eyelets for strain relief **2**.
3. Connect mains plug to the power supply.
 - The Saveris base automatically switches on after selecting the language at the base and is ready for operation.

5.6.2. Power supply via plug-in/screw connection (optional)

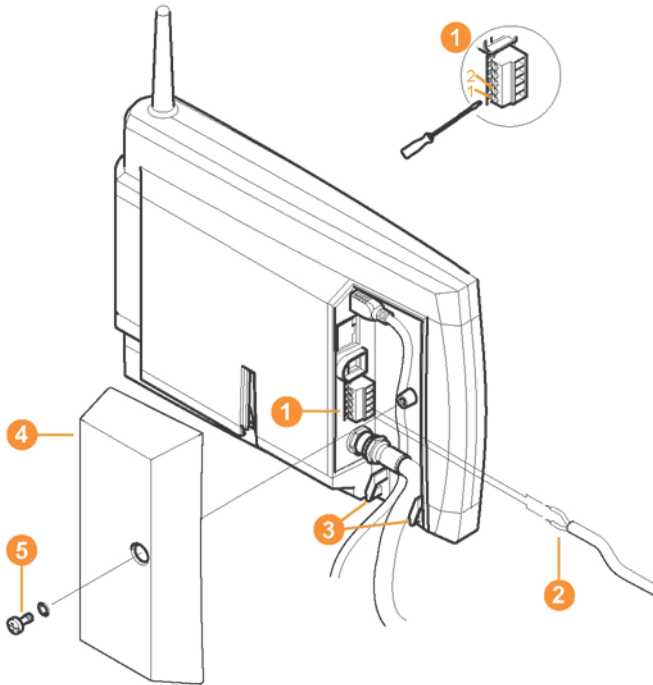

1. Loosen clamping screws ❶ no. 1 and no. 2.
2. Insert cable ❷ in the terminals as shown.
Observe permissible operating voltage!
 - The Saveris base automatically switches on after selecting the language at the base and is ready for operation.
3. Tighten clamping screws.
4. Ensure that cabling cannot be pulled out using a cable tie at the eyelets for strain relief ❸.

5.7. Connecting USB cable (optional)

For the commissioning, you can connect the Saveris base via a USB cable to the computer on which the Saveris client is installed. For this, first connect the USB cable to the Saveris base.

i During continuous operation, operate the base via the network cable, not via the USB cable. In combination with virtual systems, a USB connection works unreliably, which is why we recommend connecting the base via Ethernet.

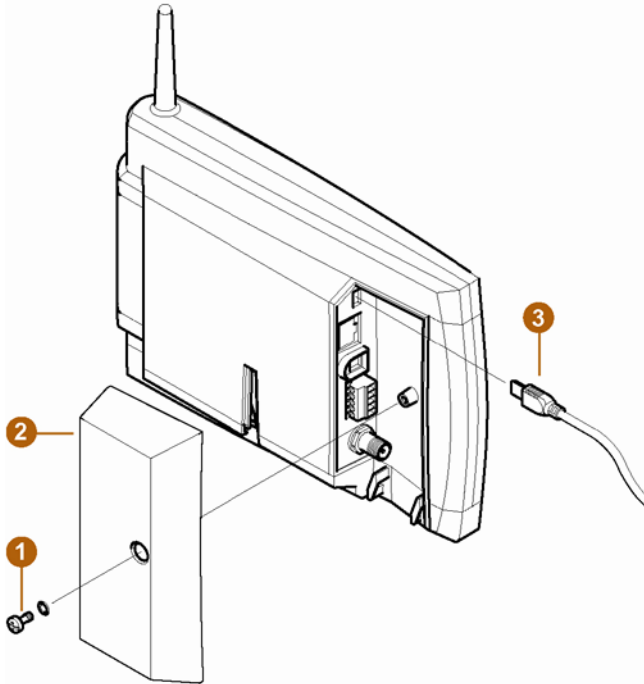

> Plug the USB cable **1** into the Saveris base.

i Do not screw on the cable cover of the Saveris base until after the commissioning and removal of the USB cable; see [Disconnecting USB cable](#), page 56.

5.8. Inserting batteries in the probes

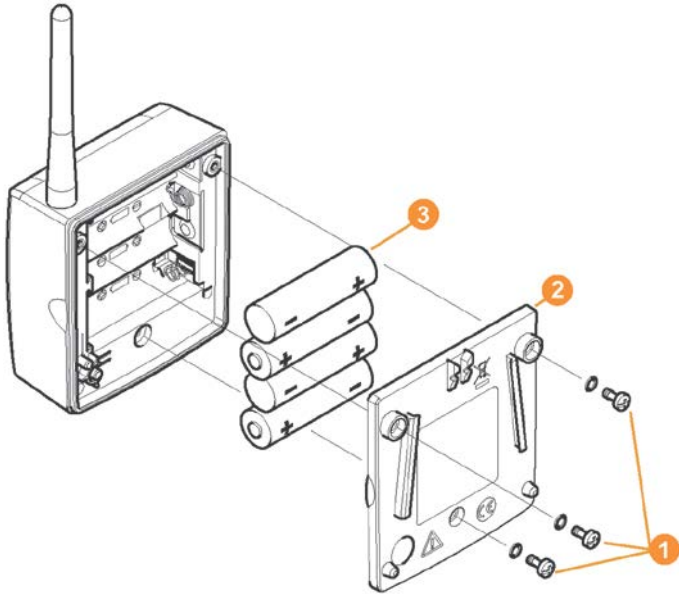

1. Loosen screws **1** on the rear of the probe.
2. Remove housing cover of probe **2**.
3. Insert batteries **3**.



Ensure that you insert the batteries correctly.
The correct polarity is illustrated in the respective battery compartment.

4. Place housing cover on probe housing.
5. Screw cover down close to the housing.



A control switch is located in the housing that is actuated through the cover. To do so, the cover must be screwed to the probe housing without a gap.
If the cover is not screwed on without a gap, the probe cannot be operated.



Transport note: If the probe is to be sent via air freight, the batteries must be removed beforehand to avoid unintended radio communication.

5.9. Connecting radio probe

i You can connect a maximum of 15 probes to the Saveris base directly via radio.

In addition, you can operate 15 probes per converter and 5 more probes per router or router cascade at the Saveris base.

Note that a maximum of 450 channels can be processed by the Saveris software.

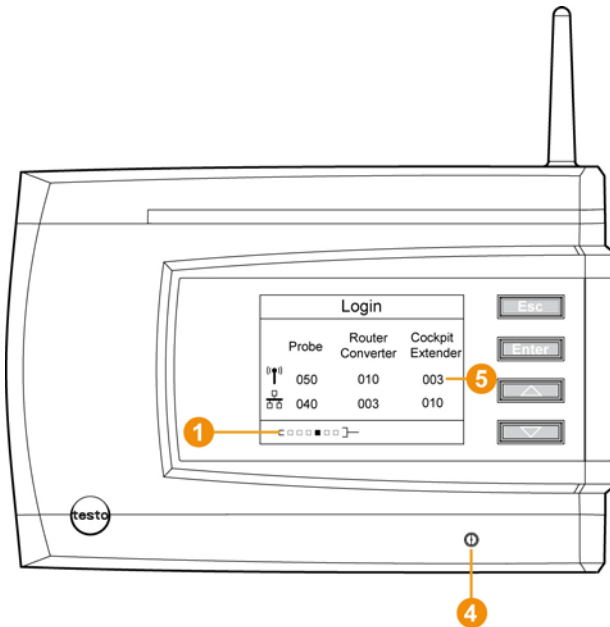

1. Change to the **Info System** menu at the Saveris base with the **[▼]** button.
2. Press **[Enter]** to call up the **Login** function.
 - The status bar **1** in the display shows that the Saveris base is ready for probe detection.

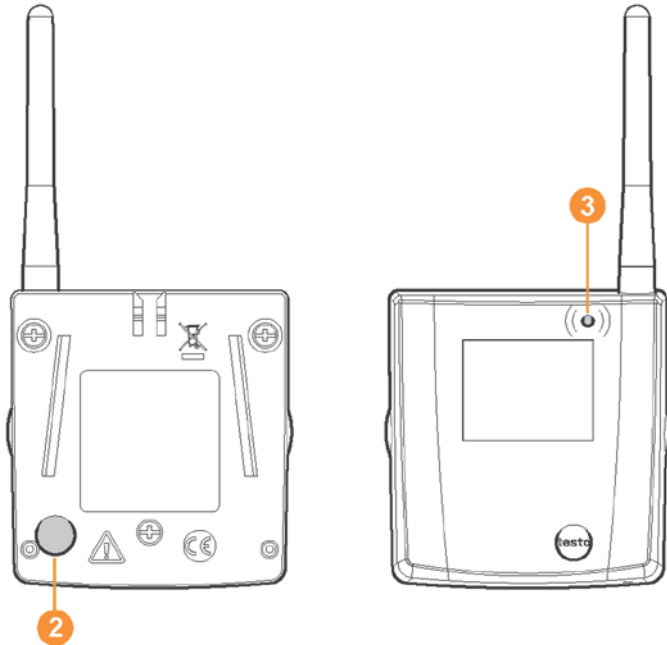

- ✓ With Saveris H2D/H4D radio probes, the external humidity probe must be connected.
- 3. Hold down the connect key **2** on the rear of the probe until the LED **3** at the probe begins to flash orange.
- The LED **3** at the probe briefly turns green if this was detected by the Saveris base.
The LED at the Saveris base **4** briefly flashes green and a prompt appears in the display of the base for the connection of more probes or routers.

i Multiple probes cannot be connected at the Saveris base simultaneously. Multiple probes can only be connected one after the other.

- 4. At the Saveris base, press the
 - **[Esc]** key if no more components are to be connected.
 - A note on the required performance of the startup assistant is shown on the display for about ten seconds. Then the Saveris base changes to the **Info System** menu in which the number of connected components **5** is now shown.
 - Press **[Enter]** if further components are to be connected; see previous step.

5. Position the probes precisely at their measurement points to check the radio link.
6. Briefly press the connect key **2** on the rear of the probe.

If the LED **3** at the probe flashes

- green, a radio link exists.
- red, no radio link exists.

i If no radio link to the Saveris base exists even after a change of location of the probe, connect a router to the Saveris base; see Integrating a Saveris router (optional), page 58.

5.10. Installing Saveris software

- > Before the installation: End all running programs.

i Administrator rights are required for installation. Log in directly as an administrator, not via **Perform as....**

i If you are installing Saveris Professional Server on a computer with Windows® Vista, you must allow **Incoming connections** in the settings of Windows® Firewall.

i If you are installing multiple clients in a network, make sure that no simultaneous changes are made to the system configuration by the clients during simultaneous operation of the clients.

1. Insert CD with Saveris software in the CD-ROM drive. If the installation program does not start automatically, open Windows® Explorer and start the **index.html** file on the CD.

i Once you have received the installation file, e.g. via e-mail, use the file Setup.exe at the highest level of the installation disk.

2. Select the desired installation options.
3. Follow the directions of the installation wizard.

When installing the components that are preconditions for the Saveris Professional Server, note that:

i During the installation, the licence-free database system Microsoft® SQL Server® 2008 R2 Express is installed – if this is not already present.

The database is protected by the so-called "sa password", the password for the database administrator, to prevent unintended changes to the database.

When installing the Saveris Client and Saveris Viewer, note that: The Saveris Professional Viewer has only a limited functionality. You can thus analyze and process data sequences, for example, but cannot configure alarms or create reports.

i During the installation, you require the name or IP address of the computer on which the Saveris Professional Server is installed.

i With the Saveris Professional Client, the USB driver for the connection of the base is installed for the commissioning.

If the Saveris base is not recognized as new hardware when connected to the computer, the driver must be manually installed.

> After completing the installation, restart the computer and log in with the same user name as before.

5.11. Starting up hardware

Use the installation instructions when starting up the system for the first time.

The following requirements must be fulfilled for the rest of the startup process for the hardware:

- the Saveris base is ready for operation,
- all probes are registered on the Saveris base,
- the Saveris software is installed,
- a project has already been created and
- measurement operation has been ended.

1. Connect the Saveris base via the USB or network cable to the computer on which the Saveris client is installed.

i For continuous operation of the system, it is recommended that the Saveris base be connected to the computer via an Ethernet cable.

- The startup wizard starts.

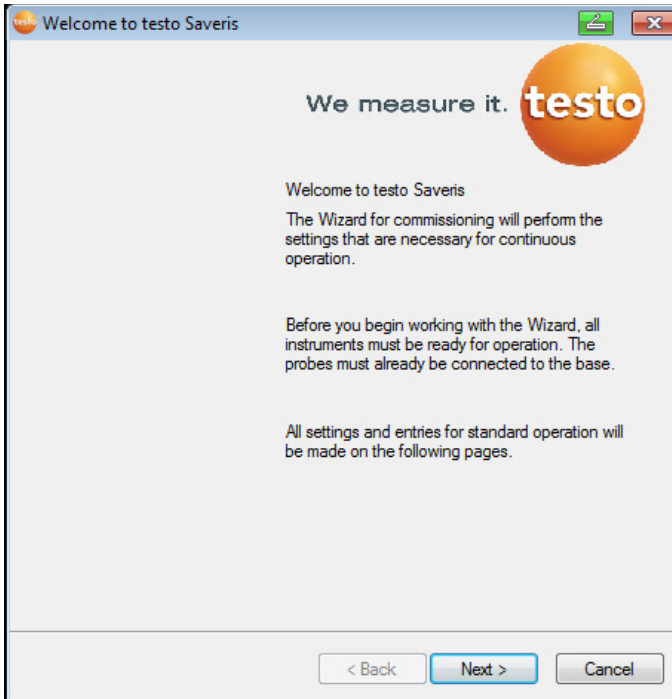

2. Click on **[Continue >]**.
- The configuration data of the Saveris base are shown.

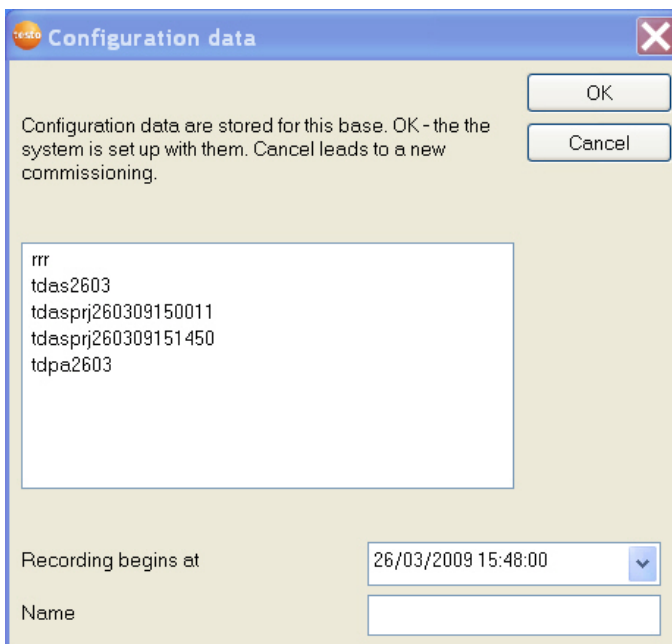

3. Enter the project name in the **Name** field.
4. Determine which configuration data are to be used:
 - Click on **[Cancel]** to reconfigure the project without using predefined configuration data.
 - Refer to installation instructions for information on reconfiguring a project.
 - Mark an existing project and click on **[OK]** to adopt the configuration data of the marked project for the new project.
 - The system settings of the Saveris base that are based on the marked project are shown.

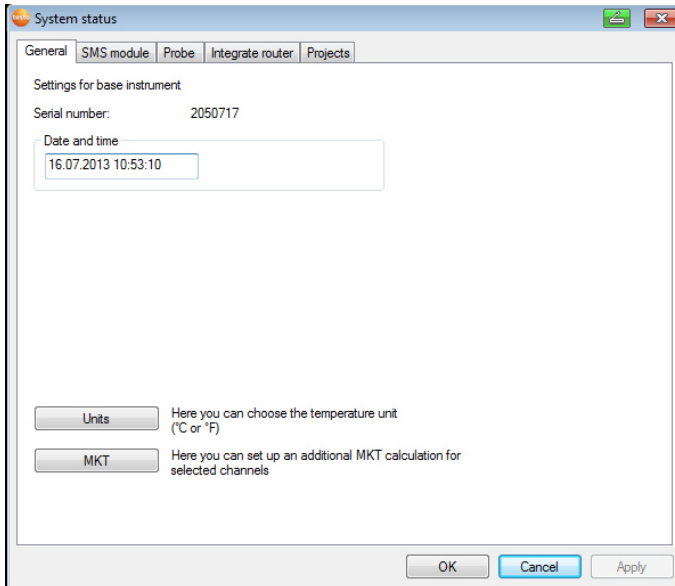

5. Click on **[Units]** to change the temperature unit for the system.
6. Click on **[MKT]** (mean kinetic temperature) to simulate the effect of temperature fluctuations over a certain period of time.
 - > Mark the channel.
 - > Click on **[Add]** to start the MKT calculation for the selected channel.



Several timestamps can be set for each channel.

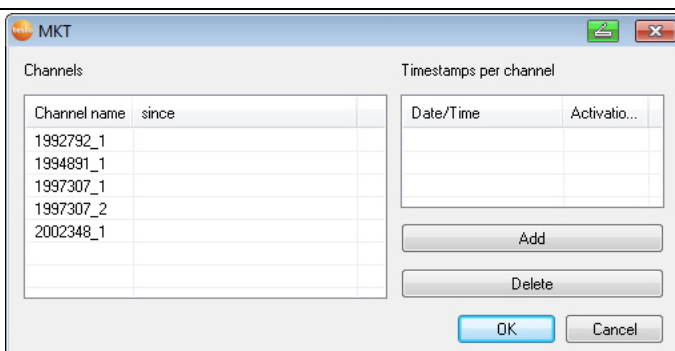

7. Click on **[OK]**.
8. Make any further changes to the existing system settings as required (see installation instructions).

5.12. Disconnecting USB cable

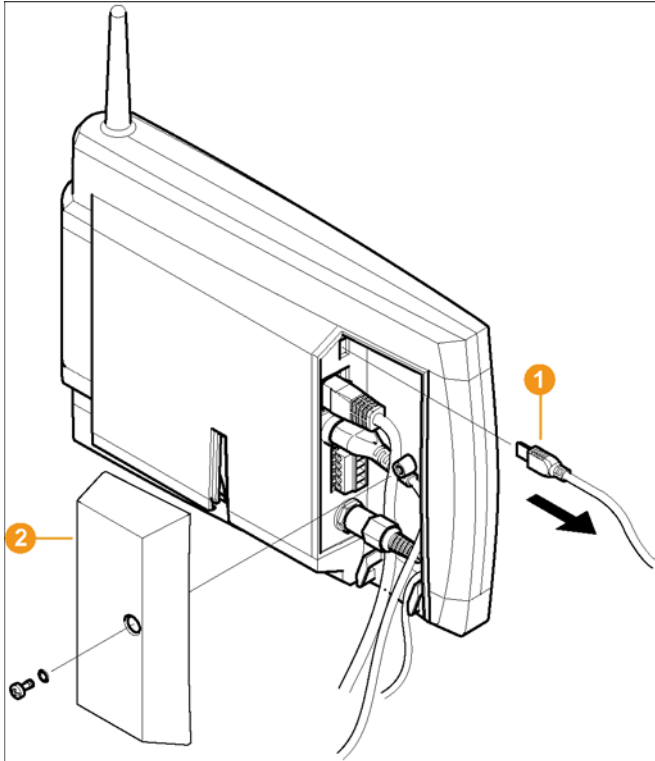

1. Disconnect the USB cable **1** from the Saveris base.
2. Place the cover **2** on the Saveris base and screw it down.

5.13. Starting Saveris software

- i** Ensure that the Saveris software is not already open, for example in multi-user operation under Windows® Vista.
- If multiple clients are installed in a network, make sure that no simultaneous changes are made to the system configuration by the clients during simultaneous
-

operation of the clients.

1. Select **[Start] | All Programs | Testo |**
 - **Saveris Client.**
The entry is available if Saveris Professional Client is installed
 - **Saveris Viewer.**
The entry is available if Saveris Professional Viewer is installed
- The **Testo Saveris software** program window is opened with the **Select project** dialogue.

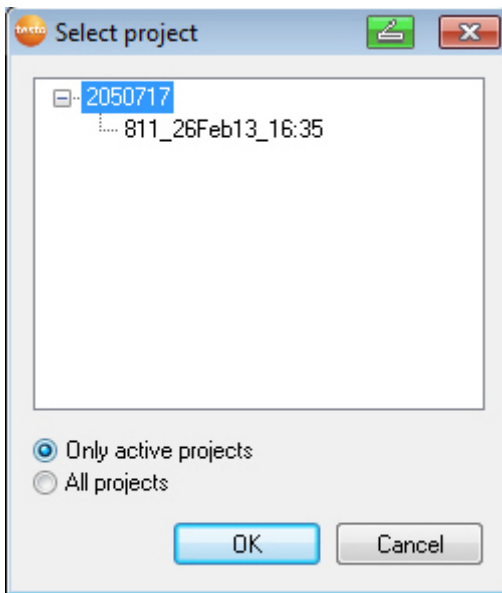

i If the software will not start, check whether the **testo tdassvcs** service is started in the service management of the operating system and restart it, if needed.

2. Select the
 - **Only active projects** option if the data from a running project should be opened
 - **All projects** option if the data from a completed project should be opened.
3. Select the project that is to be opened in the tree structure.

4. Confirm with **[OK]**.
- The **Testo Saveris software** program window is shown with the selected data record in the foreground.

5.14. Expand measuring system

In this chapter, you learn how to integrate the Saveris router, converter, Ethernet probes, extender, cockpit units and analog coupler into the measuring system.

-
- i**
- With base V1, no transportation (mobile use) is possible.
 - With base V2, mixed operation with V1 components is only permissible for stationary use.
-

5.14.1. Integrating a Saveris router (optional)

You can use a Saveris router to optimize radio communication under poor structural conditions or to extend the radio path. The router receives the signals of the radio probes and forwards them to the Saveris base. Maximum extension of the radio path can be achieved by connecting three routers in series.

-
- i**
- The measurement data of up to five radio probes can be transmitted per router or router cascade to the Saveris base.

Up to 30 routers can be incorporated into the measurement system. The Saveris base can communicate directly with a maximum of 15 routers.

The integration of a router is performed in three steps:

1. Connecting the router to the power supply.
2. Registering the router on the Saveris base.
3. Assigning the radio probe to the router.

-
- i**
- When positioning a router, please note the following points:
- When integrating several probes via a router, the probe with the weakest radio link determines the position of the router.
Mount the router in such a way that this probe has an ideal radio link.
 - Probes and router should be mounted so that the antennas are pointing upwards.
 - The radio link between probes and the router, as well as the router and the Saveris base, should not be strongly influenced by structural conditions
-

(walls, shelves, etc.).

Mount the router and probe so that "visual contact" exists with as many radio links as possible.

5.14.1.1. Connecting router with power supply (mains unit)

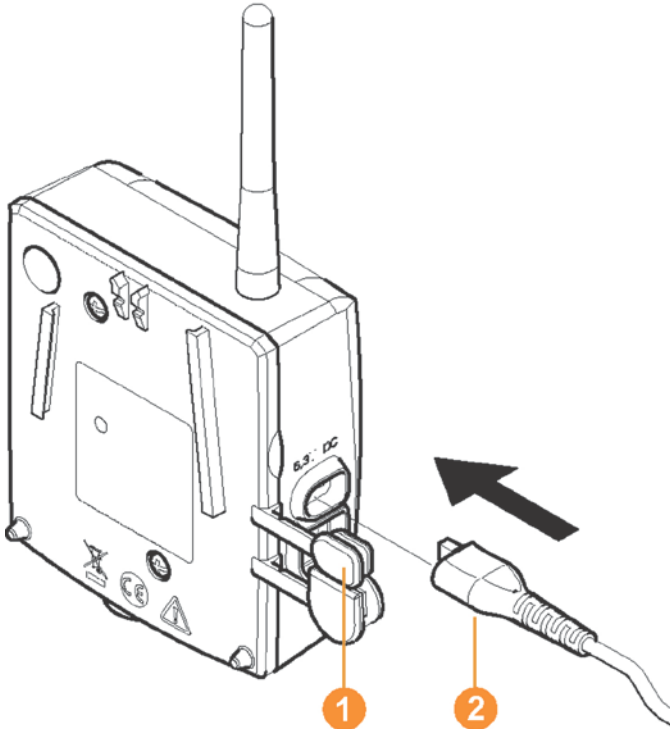

1. Open cover ①.
2. Insert mains cable ②.
3. Insert mains plug into a socket.

i The wall mounting of a router is performed in the same ways as for a probe; see "Mounting the probe on the wall".

5.14.1.2. Connecting router with power supply (AC/DC)

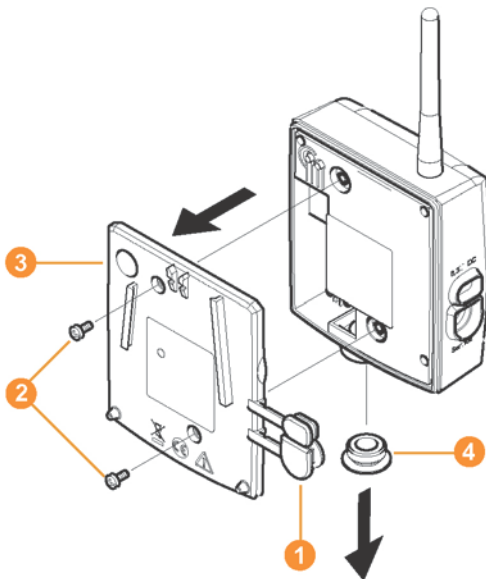

- 1 Remove protection caps 1.
- 2 Loosen screws 2 on the rear of the router.
- 3 Remove housing cover of router 3.
4. Unscrew and remove cover cap of cable opening 4.

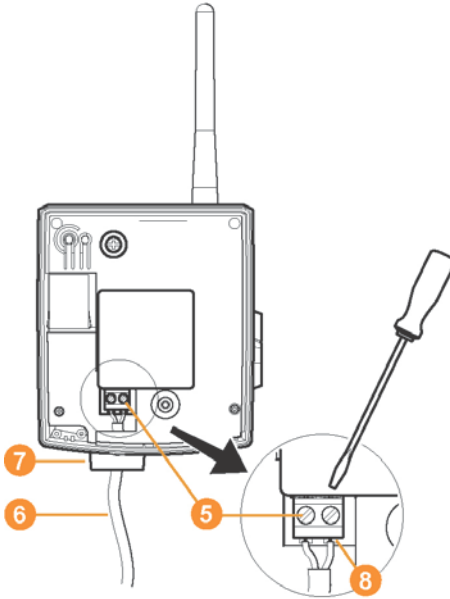

5. Loosen clamping screws 5.
6. Route cabling 6 through the cable opening 7 and insert in the terminals 8.



It is not necessary to note the polarity.

7. Tighten clamping screws.

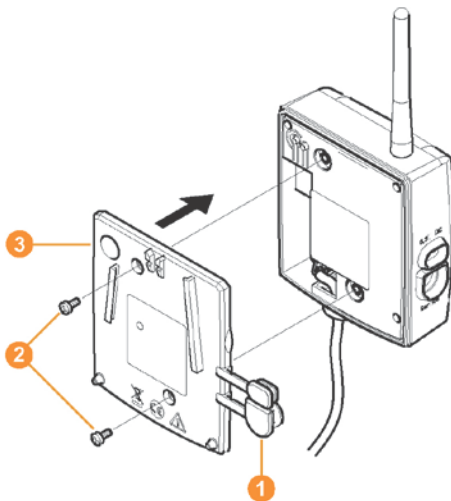

8. Place housing cover **3** on the router.
9. Screw on housing cover **2**.
10. Insert protection caps **1**.

i The wall mounting of a router is performed in the same ways as for a probe; see "Mounting the probe on the wall".

5.14.1.3. Connecting router

i You can connect a maximum of 30 routers to the Saveris base.
The Saveris base can communicate directly with a maximum of 15 routers.

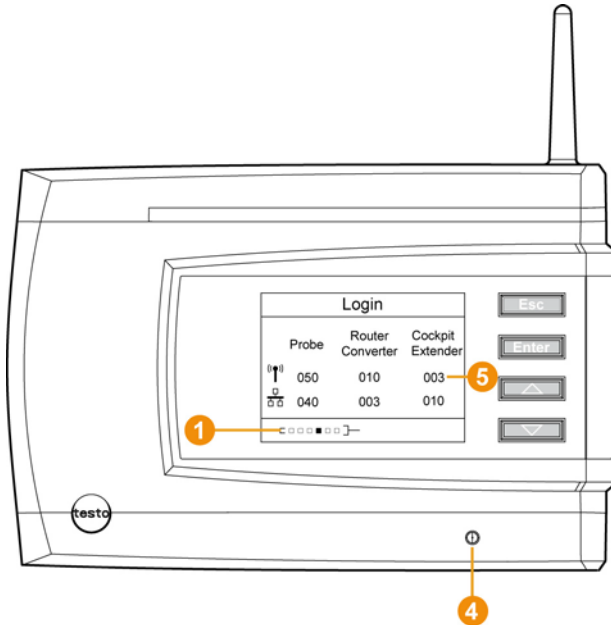

1. Change to the **Info System** menu at the Saveris base with the **[▼]** button.
2. Press **[Enter]** to call up the **Login** function.
 - The status bar **1** in the display shows that the Saveris base is ready for router detection.

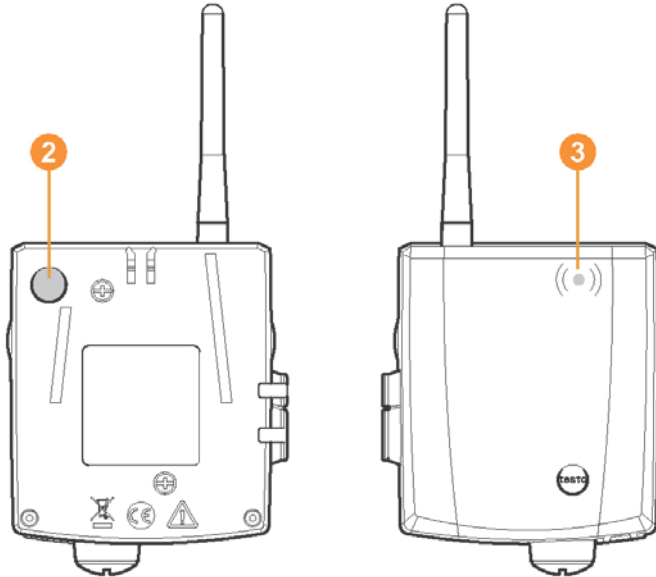

3. Hold down the connect key **2** on the rear of the router until the LED **3** at the router begins to flash orange.
 - The LED **3** at the router briefly turns green if this was detected by the Saveris base.
The LED at the Saveris base **4** briefly flashes green and a prompt appears in the display of the base for the connection of more probes or routers.

i Multiple routers cannot be connected at the Saveris base simultaneously. Multiple routers can only be connected one after the other.

4. At the Saveris base, press the
 - **[Esc]** key if no more components are to be connected.
 - A note on the required performance of the startup assistant is shown on the display for about ten seconds. Then the Saveris base changes to the **Info System** menu in which the number of connected components **5** is now shown.
 - Press **[Enter]** if further components are to be connected; see previous step.

5.14.1.4. Assigning probes

-  To assign a probe to a router, both must be connected in the Saveris base.

- Under **Start | All Programs | Testo** click on **Saveris Startup Wizard**.
 - The welcome dialogue of the startup assistant is shown.

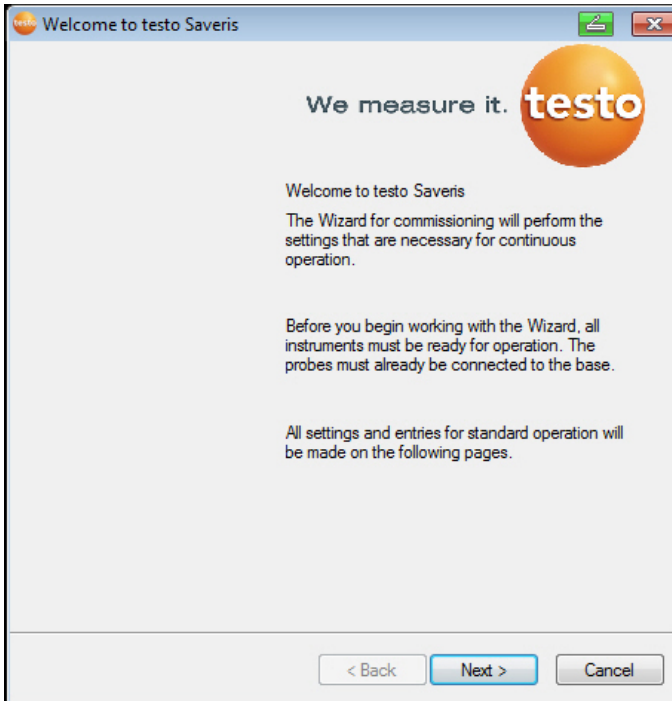

- Click on **[Continue >]**.
 - The **System status** dialogue with the **General** tab is shown.

-
8. Briefly press the connect key on the rear of the router.
If the LED on the front of the router flashes
- green, a radio link to the Saveris base exists.
 - red, no radio link to the Saveris base exists.

i If no radio link exists after changing the location of the probe and/or router, introduce a converter; see "**Integrating Saveris converter (optional)**".

i If you want to use probes in a router cascade, see Connecting routers in series, page **67**

see Connecting routers in series, page **67**

5.14.1.5. Connecting routers in series

i Max. three routers can be cascaded in series.
The measurement data of up to five radio probes can be transmitted per router cascade to the Saveris base. The wireless probes can be connected to any router in the cascade.
A converter can be connected upstream of the router cascade.

- ✓ All routers are connected to the power supply and registered on the Saveris base.
- 1. Under **Start | All Programs | Testo**, click on **Testo Saveris Startup Wizard**.
- The welcome dialogue box for the startup wizard is displayed.

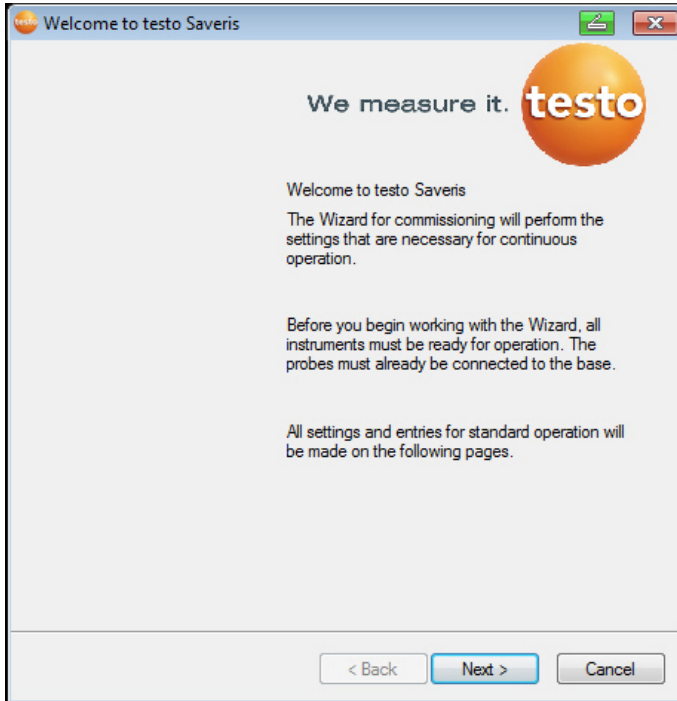

2. Click on **[Next >]**.
 - The **System status** dialogue box is displayed with the tab **General**.

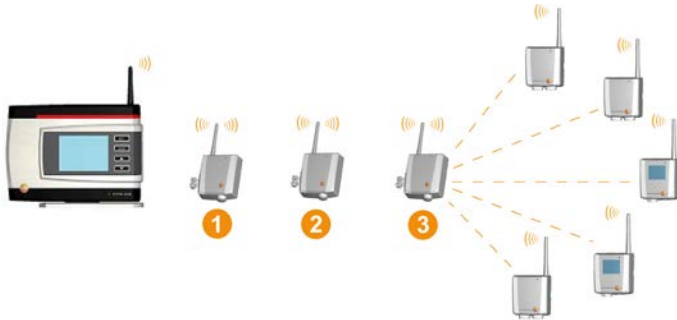

6. Click on **[Ok]**.
7. Check assignment in the structure diagram and click on **[Next >]**.
8. Place the routers in their installation locations to check the radio connections.
9. Briefly press Connect on the back of the router that is next in the series after the Saveris base (router 1 in the diagram).
If the LED on the front of the router flashes
 - green, a radio link to the Saveris base exists.
 - red, no radio link to the Saveris base exists.
10. Briefly press Connect on the back of the router that comes after the first router in the series (router 2 in the diagram).
If the LED on the front of the router flashes
 - green, a radio link to the router connected upstream of it in the series exists.
 - red, no radio link to the router connected upstream of it in the series exists.
11. Briefly press Connect on the back of the router that comes after the second router in the series and is therefore the furthest from the base (router 3 in the diagram).
If the LED on the front of the router flashes
 - green, a radio link to the router connected upstream of it in the series exists.
 - red, no radio link to the router connected upstream of it in the series exists.



If no radio link exists after changing the location of the router, introduce a converter; see "**Integrating Saveris converter (optional)**".

If you want to integrate probes into the router cascade, see Assigning probes, see Connecting routers in series, page 67.

5.14.2. Assigning an IP address to the Saveris base (optional)

If an Ethernet probe, converter and/or extender is integrated into the Saveris system, a static IP address should first be assigned for the Saveris base.

For assignment of an IP address, the software must be installed () and the programming adapter 0440 6723 must be used.

1. Undo the screw connection 1 and remove the base plate 2 from the Saveris base.

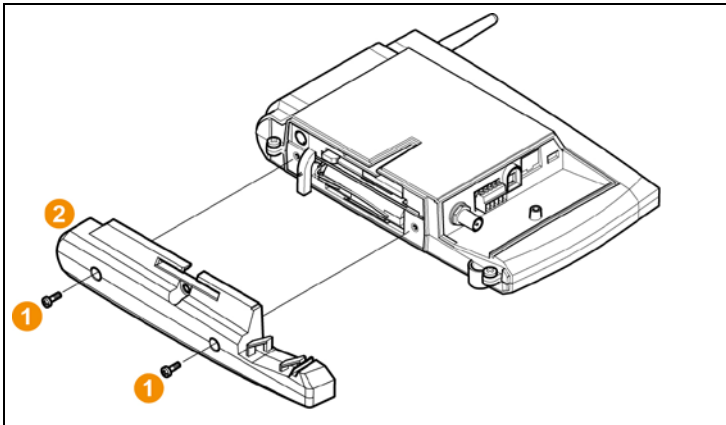

2. Plug the USB cable into the Testo programming adapter (0440 6723) and connect to the service interface for the base.

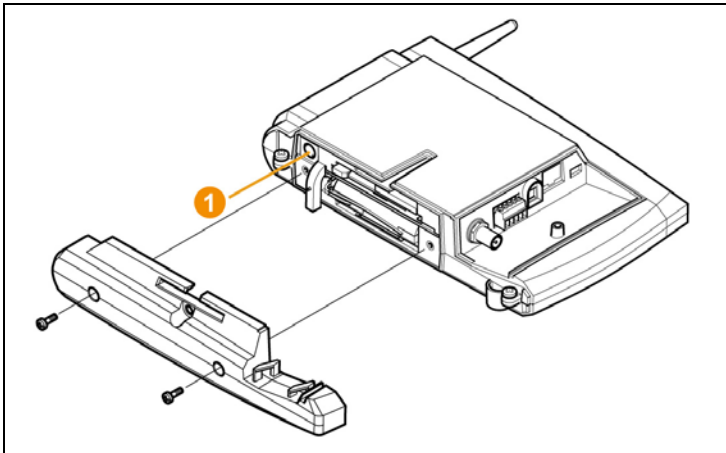

3. Connect the USB cable to the computer.
4. Via **Start | All Programs | Testo | Testo Saveris Ethernet Wizard**, open the wizard for entering the connection settings.
5. Follow the wizard's instructions and assign the IP address for the Saveris base.

see Installing Saveris software, page 51

5.14.3. Integrating Saveris converter (optional)

If the distance between the radio probe or router is too large for a radio transmission, you can integrate a Saveris converter into the measuring system. The converter is connected to the Saveris base by means of an Ethernet cable and converts the radio signals to Ethernet signals.

i The measurement data of up to 15 radio probes/routers can be transmitted with the converter to the Saveris base.

You can connect several converters to the Saveris base using a so-called switch. In this context, note that a maximum of 150 probes can be connected or 450 measurement channels recorded at the Saveris base.

i The preparation for the commissioning of a converter is performed as with a Saveris Ethernet probe; see **Connecting the network cable.**, page 74 up to and including see Connecting Ethernet probe with the Saveris base, page 80

Connecting probe or router to converter

1. Briefly press the connect button on the rear of the converter.
 - The LED at the converter lights green and the converter is ready for probe detection.
2. Press the connect key on the rear of the probe/router until the LED at the probe/router begins to flash orange.
 - The LED at the probe/router briefly turns green if this was detected by the Saveris converter.

The probe/router is connected at the converter and this transmits the measurement data to the Saveris base.

5.14.4. Integrating Saveris Ethernet probe (optional)

In addition to the Saveris radio probes, you can use probes that are connected to the Ethernet interface of the Saveris base. This also enables the data transfer from the probe to the base over long stretches if you do not wish to use a router or converter.

All Ethernet components (Ethernet probe, converter, extender, base where applicable) must be assigned IP addresses through the programming adapter ① (0440 6723) via the Ethernet wizard.

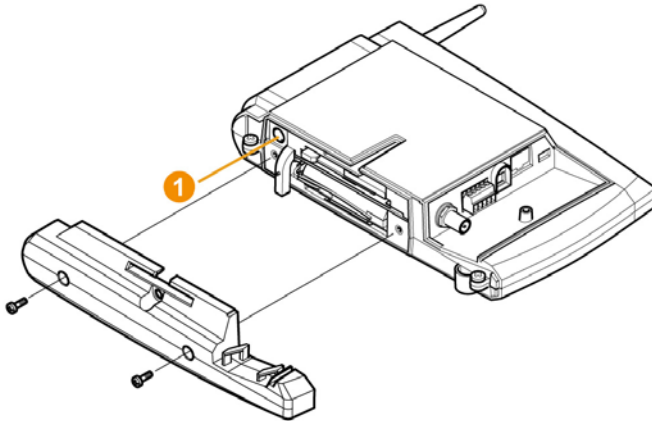

i If your computer has the Dynamic Host Configuration Protocol (DHCP), the Ethernet components automatically retrieve the IP address. Because the DHCP address changes as standard following a certain period of time, the base should be assigned a fixed IP address. The IP address of the base must be manually assigned to the probes, extenders and converters through the adapter.

This chapter contains all required information for this.

i You can connect several Ethernet probes to the Saveris base using a so-called switch. In this context, note that a maximum of 150 probes can be connected or 450 measurement channels recorded at the Saveris base.

5.14.4.1. Connecting the network cable.

- i** Only use high-quality network cables with a diameter between 5.8 mm and 6.8 mm to ensure the leaktightness of the probe housing.
Only use cables with an intact clip end.
-

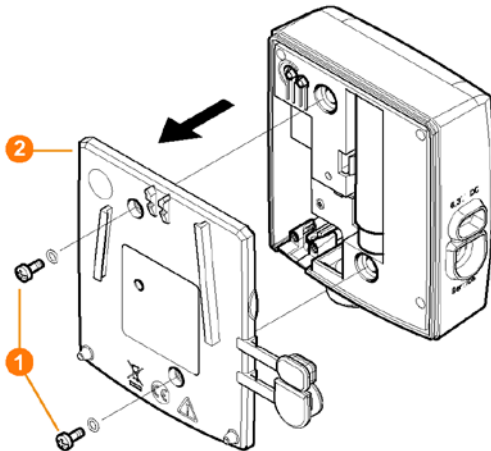

1. Loosen screws **1** on the rear of the probe and remove the housing cover **2**.

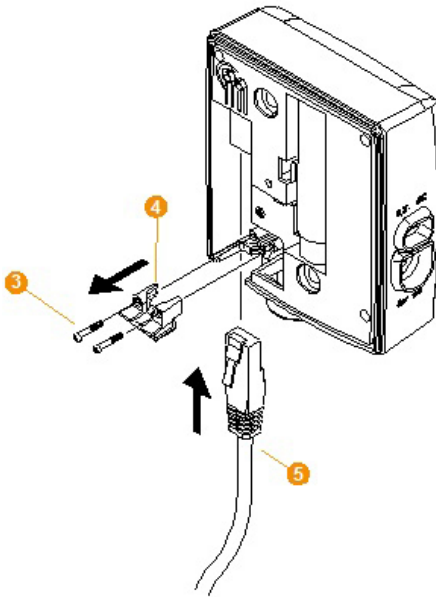

2. Loosen screws 3 at the panel 4 for the network cable and remove panel.
3. Slide network cable 5 with the tongue pointing up into the Ethernet jack until it engages.

i If you wish to connect the Saveris Ethernet probe to the power supply via the 24 V AC/DC plug-in/screw terminal and not via the mains adapter, do not screw on the housing cover until after connecting the power supply. The connection for the power supply via plug-in/screw terminal is performed as with the Saveris router; see Connecting router with power supply (AC/DC), page 60.

4. Place the housing cover on the probe and screw it down.

i You can connect the probe to the network via a network hub or directly at the Saveris base via the Ethernet jack.

5.14.4.2. Connecting Ethernet probe with power supply (mains unit)

i The connection for the power supply via 24 V AC/DC plug-in/screw terminal is performed as with the Saveris router; see Connecting router with power supply

(AC/DC), page 60.

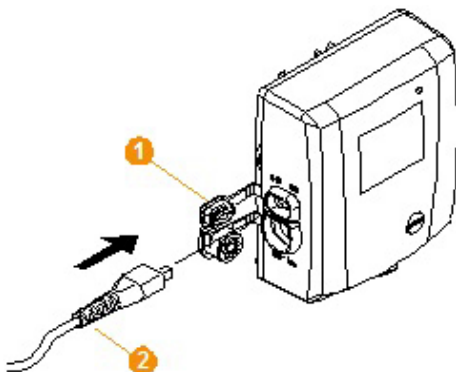

1. Open the cover ① for the power supply.
2. Insert mains cable ②.
3. Insert mains plug into a socket.

5.14.4.3. Connecting USB cable and installing driver (optional)

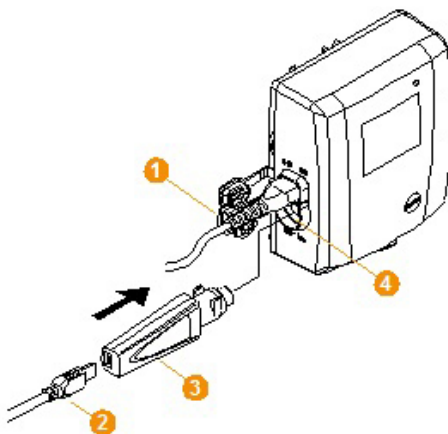

1. Open the cover ① of the service interface at the Saveris Ethernet probe.
 2. Connect the USB cable ② to the testo adapter (0440 6723) ③ and insert into the service interface ④.
- ✓ With Saveris H4E Ethernet probes, the external humidity probe must be connected.

3. Connect the USB cable to the computer.
 - The wizard for the installation of the driver is started.
4. Follow the directions of the installation wizard.

5.14.5. Assigning an IP address to the Saveris base (optional)

If an Ethernet probe, converter and/or extender is integrated into the Saveris system, a static IP address should first be assigned for the Saveris base.

For assignment of an IP address, the software must be installed () and the programming adapter 0440 6723 must be used.

1. Undo the screw connection 1 and remove the base plate 2 from the Saveris base.

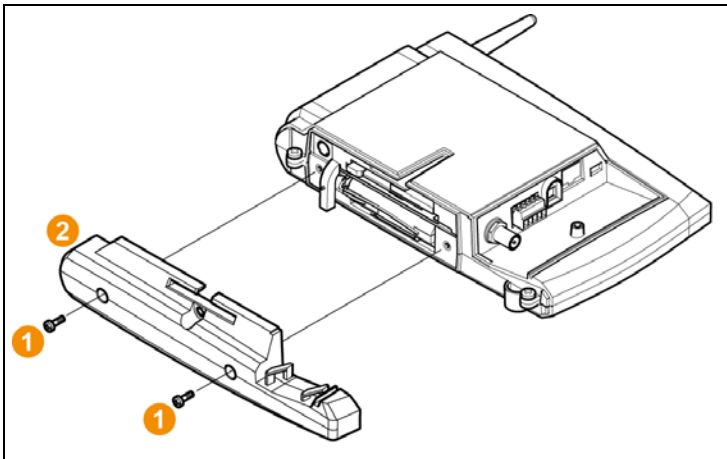

2. Plug the USB cable into the Testo programming adapter (0440 6723) and connect to the service interface for the base.

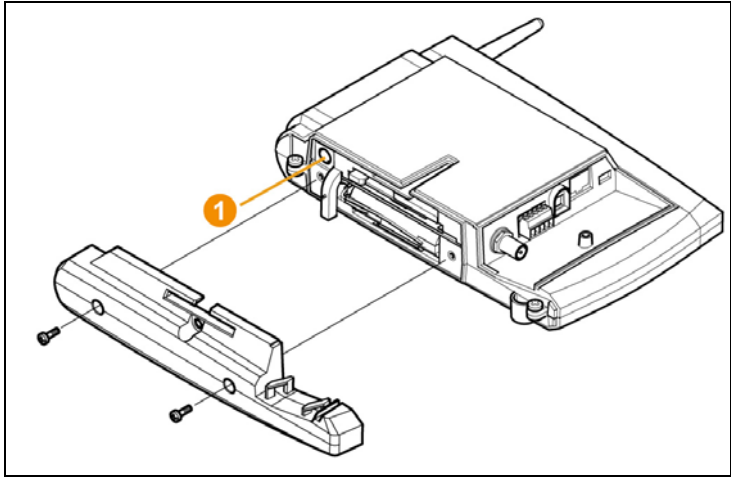

3. Connect the USB cable to the computer.
4. Via **Start | All Programs | Testo | Testo Saveris Ethernet Wizard**, open the wizard for entering the connection settings.
5. Follow the wizard's instructions and assign the IP address for the Saveris base.

see Installing Saveris software, page 51

5.14.5.1. Assigning connection data

You must now enter the connection settings for the Ethernet probes.

1. Open the wizard for entering the connection settings via **Start | All Programs | Testo | Testo Saveris Ethernet Wizard**.
 - The wizard is started with the welcome dialogue.

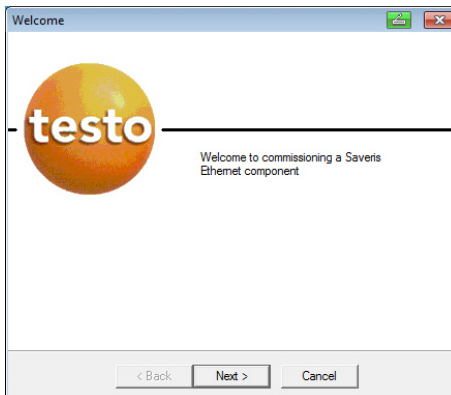

2. Click on **[Continue >]**.
 - The **Instrument address allocation** dialogue is shown.

3. Enter **IP address**, **Netmask** and **Gateway**.

i The first two blocks of the IP address must match those from the Saveris base in this example. The last two blocks can be selected freely, but must differ from the Saveris base.

The IP address, the netmask and the gateway can be read off at the Saveris base in the **Info Base** menu; see Displays, page 17.

4. Click on **[Continue >]**.
 - The dialogue for the entry of the connection data for the base is shown.

5. Enter IP address or DNS entry of the Saveris base.

i The IP address can be read off at the Saveris base in the **Info Base** menu; see Displays, page 17.

i You can determine the DNS entry using the label on the back of your Saveris base.
The DNS entry consists of the word "testo" and the last six digits of the "MAC address" on the label excluding spaces and hyphens (e.g. testo00081B).

6. Click on **[Finish]**.

- The Ethernet probe is restarted, synchronized with the Saveris base and the number of connected Ethernet probes in the display of the base is increased by 1; see Displays, page 17.

5.14.5.2. Connecting Ethernet probe with the Saveris base

> Connect Ethernet probe to the network.

i You can connect the Ethernet probe to the Saveris base or integrate it into a network via a network hub or connect the probe directly to the Saveris base via a network cable; also see Connecting the network cable to the Saveris base page 43.

5.14.5.3. Starting up Ethernet probes

1. Via **Start | All Programs | Testo | Startup Wizard**, start the wizard to start up new hardware components.
 - The wizard opens with the welcome screen.

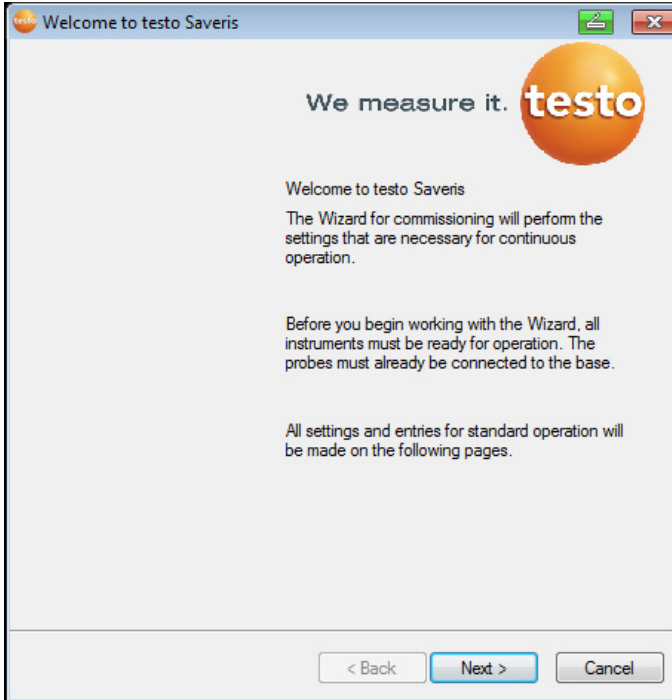

2. Click on **[Next >]**.
 - The **Commission new probe** dialogue box is displayed.

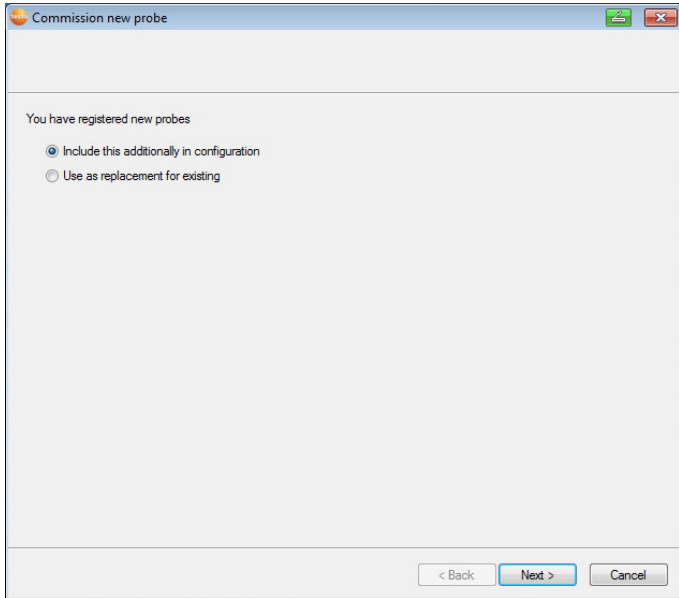

3. Leave default setting and click on **[Next >]**.
- The list of probes newly registered in the Saveris base is displayed.

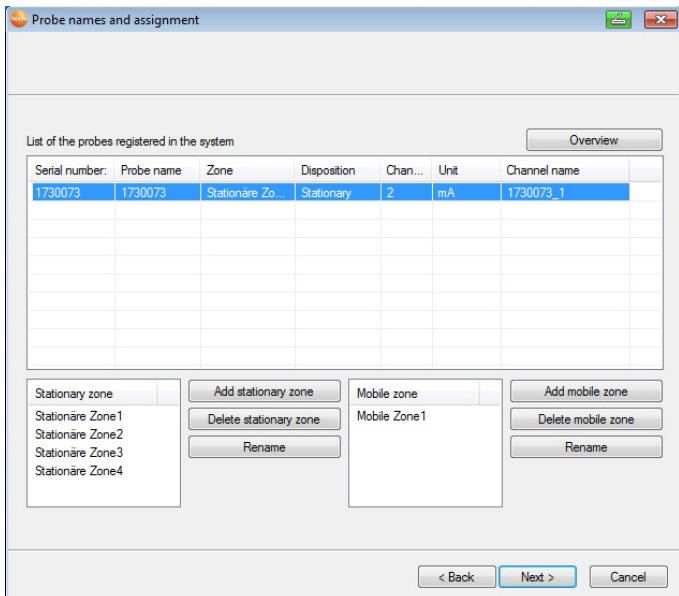

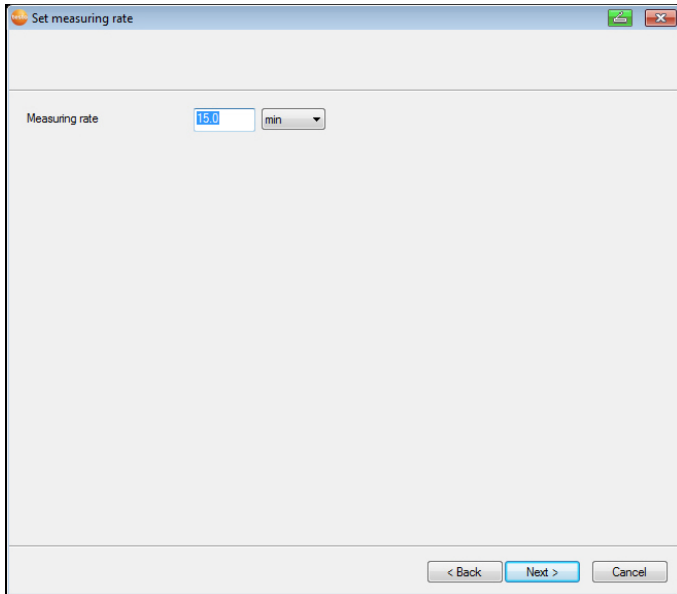

11. Enter **Measuring cycle** and define its **Unit**.



The measuring cycle determines the intervals at which a new measured value is saved in the Saveris base.

Possible settings for the unit:

- **sec** (second)
- **min** (minute)
- **h** (hour).

12. Click on **[Next >]**.

- The wizard is displayed with the start of measurement configuration and the list of newly registered probes.

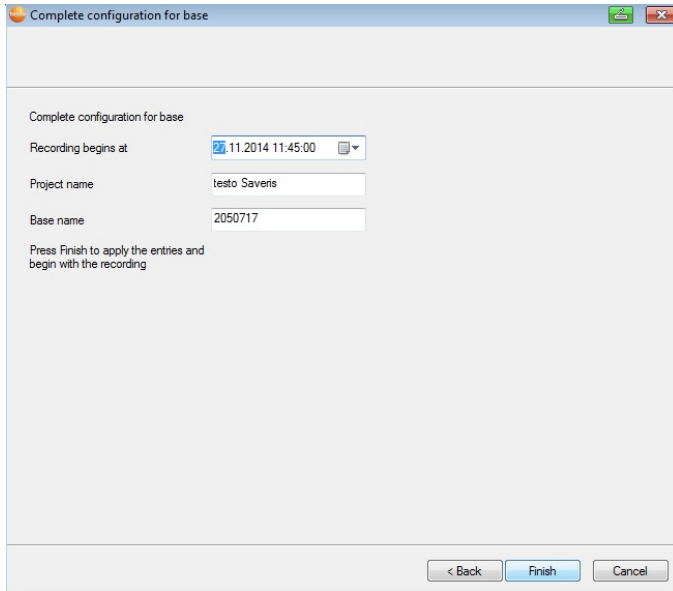

13. Postpone the start of measurement if necessary.
14. Click on **[Finish]** to end the hardware startup.
 - A message about the successful configuration of the hardware is displayed.
15. Confirm the message by clicking **[OK]**.
 - The new hardware is now ready to be used.

5.14.6. Integrating a Saveris extender³

The Saveris extender communicates automatically with all radio probes in the system that have been assigned to a mobile zone on the PC and that are within its vicinity (e.g. when the HGV is at the loading station). The mobile radio probe must not be logged into any router or converter.

The Saveris extender is used to pass on the collected probe data to the Saveris base and data from the Saveris base to the Saveris cockpit unit.

i The Saveris extender is designed for both mobile and stationary data monitoring. The fundamental difference compared to the converter is the fact that the

³ This component is only permitted for mobile monitoring in countries with a radio frequency of 868 MHz.

transmission routes of the components involved are not strictly defined in the case of the extender. The radio probes registered on the base each search for the best radio link and subsequently communicate via the relevant extender. This is a major advantage if the radio quality may be subject to geographical or temporal changes, e.g. in a warehouse.

In principle it is preferable to use the extender rather than the converter.

Please note that when using a stationary extender it is not possible to trace the transmission/communication path of the measurement data in the **System** software menu because there is no 1 to 1 connection between extender and radio probes or routers.

i The measurement data of up to 100 radio probes can be transmitted with a Saveris extender to the Saveris base. As a minimum retention time for the mobile unit on the ramp, at least two cycles are recommended for secure data transfer (30 min).

As the mobile probes only have a limited internal memory, it is necessary to ensure that they come into regular radio contact with a Saveris extender depending on the measuring cycle to enable the measurement data to be transferred.

You can connect several Saveris extenders to the Saveris base via a switch. Bearing this in mind, note that up to 20 Saveris extenders can be registered on the Saveris base with a maximum number of 150 probes or 450 measurement channels. If the connection is to be implemented via VPN, please contact our service hotline (servicehotline@testo.de) for detailed information.

i The preparation for the startup of an extender is performed in the same way as for a Saveris Ethernet probe; see **Connecting the network cable**, page 74 up to and including see Connecting Ethernet probe with the Saveris base, page 80.

5.14.7. Integrating a Saveris cockpit unit (optional)⁴

The Saveris cockpit unit is used to start and stop tours manually and display the measured values of the assigned radio probes during transportation. The driver is made aware of any limit values being breached by a red LED. The tour data can be printed out via infrared on a Testo printer (0554 0549).

A cockpit unit can save a variety of tours with time marks.

i Max. 50 Saveris cockpit units can be integrated into one Saveris system.

The Saveris cockpit unit can display the measurement data of 2 groups from 4 radio probes each (max. 32 channels). The data transfer is carried out every 15 minutes. Alarm events are forwarded immediately to the Saveris cockpit unit.

The Saveris cockpit unit is only used to display the measurement data, not for permanent storage. It is therefore important to ensure that the mobile probes come into regular radio contact with a Saveris extender or the Saveris base depending on the measuring cycle to enable measurement data to be transferred.

The output can be configured via the Saveris software.

A Saveris cockpit unit is integrated in two steps:

1. Connecting a Saveris cockpit unit to the Saveris base.
2. Fitting a Saveris cockpit unit and providing a power supply.

5.14.7.1. Registering a Saveris cockpit unit

i You can register a maximum of 50 Saveris cockpit units on the Saveris base.

⁴ This component is only permitted for mobile monitoring in countries with a radio frequency of 868 MHz.

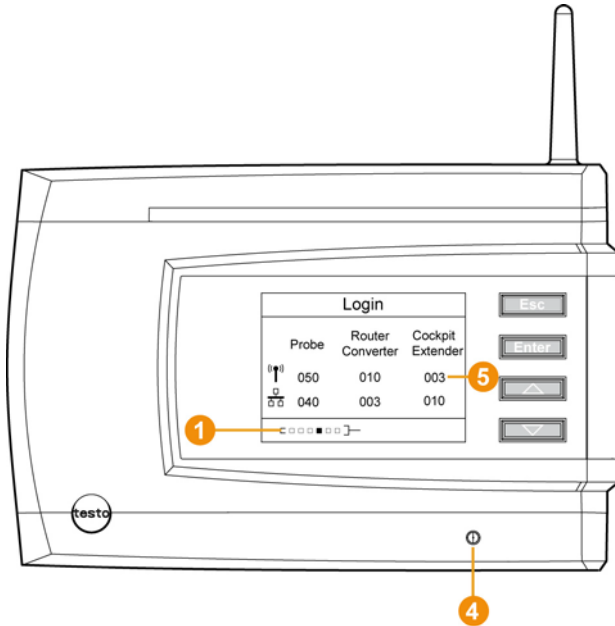

1. On the Saveris base, use the [▼] key to switch to the **Info System** menu.
2. Press [Enter] to call up the **Login** function.
 - The status bar 1 on the display indicates that the Saveris base is ready to detect the Saveris cockpit unit.

i The Saveris cockpit unit can be connected briefly to the PC via the USB port for a power supply while logging into the Saveris base. The driver search, which opens automatically on the PC, can be closed.

3. At the Saveris cockpit unit, use [▲] and [▼] to selected the required language.
4. Press [Enter] to call up the **Login** function.
 - The status bar on the display indicates that the Saveris cockpit unit is attempting to register on the Saveris base.

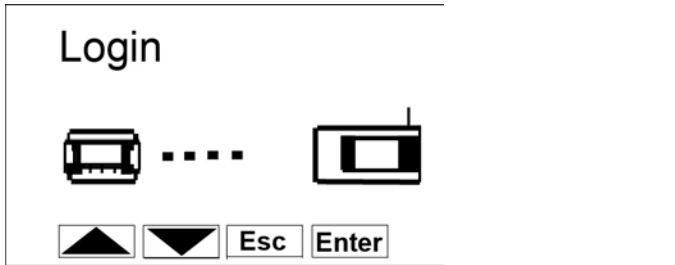

i Multiple Saveris cockpit units cannot be registered on the Saveris base simultaneously. Multiple Saveris cockpit units can only be registered one after the other.

- Once registered, the Saveris cockpit unit displays a warning about use in traffic.
- 5. Press any key to confirm the warning.
 - Saveris cockpit unit menu is open.
 - The Saveris base transfers the tour descriptions and mobile zones created in the Saveris software to the Saveris cockpit unit.

i Each time the mobile zones or tour descriptions are changed, the Saveris cockpit unit must have a radio connection to the Saveris base or a Saveris extender to enable current data to be received.

6. On the Saveris base, press
- **[Esc]** if there are no other components to be registered.
 - A note on the necessary execution of the startup wizard is shown on the display for about ten seconds. The Saveris base then switches to the **Info System** menu where the number of successful components **5** is displayed.
 - Press **[Enter]** if there are no other components to be registered; see previous step.

5.14.7.2. Fitting a Saveris cockpit unit in the driver's cab and connecting to a power supply

i Do not fit the Saveris cockpit unit while driving. Ensure that the Saveris cockpit unit does not obstruct your line of vision while driving. Observe road traffic regulations. Always use the adapter supplied (article no. 0554 1038) for connecting to the vehicle electrical system. We recommend connecting to a permanently supplied

socket.

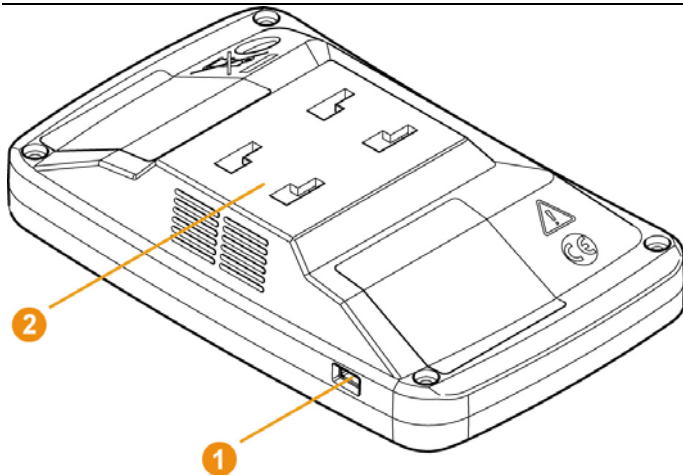

1. Push the mini USB cable into the connection port **1**.
 - > At below 15°C: Warm the windscreen and sucker.
 - > If the windscreen is dirty: Clean the windscreen with a suitable cleaning agent.
2. Secure the mount on the windscreen using the sucker.



3. Insert the mount into the guide **2** until you hear it click into place.
4. Connect adapter (article no. 0554 1038) with the USB cable and plug into the vehicle socket.
 - Green LED lights up when the Saveris cockpit unit is supplied with power.
 - Saveris cockpit unit is ready for use.

-
- i** Before each trip, particularly when temperatures fluctuate, check that the mount is secure.
-

5.14.8. Integrating Saveris analog coupler (optional)

Using a Saveris analog coupler, you can integrate a transmitter with standardized current/voltage interfaces into the Saveris measuring system and monitor it. The Saveris analog coupler thereby enables the integration of additional parameters other than temperature and humidity into the Saveris measuring system.

The integration of an analog coupler is performed in three steps:

1. Connect transmitter to analog coupler.
2. Connect analog coupler to the Saveris base.
3. Parameterize analog coupler.

Connecting transmitter to analog coupler

You can supply the transmitter with power via the analog coupler or select a separate power supply.

The circuit diagrams can be found in the analog coupler startup instructions which are delivered together with the analog coupler.

Connecting analog coupler to the Saveris base.

The analog coupler U1 is connected to the Saveris base like a Saveris radio probe (see **Connecting radio probe** page 49)

The analog coupler U1E is started up and connected to the Saveris base like a Saveris Ethernet probe (see **Integrating Saveris Ethernet probe (optional)** page 73)

Parameterizing analog coupler with Startup Wizard

1. Under **Start | All Programs | Testo** click on **Testo Saveris Startup Wizard**.
 - The welcome dialogue of the startup wizard is shown.

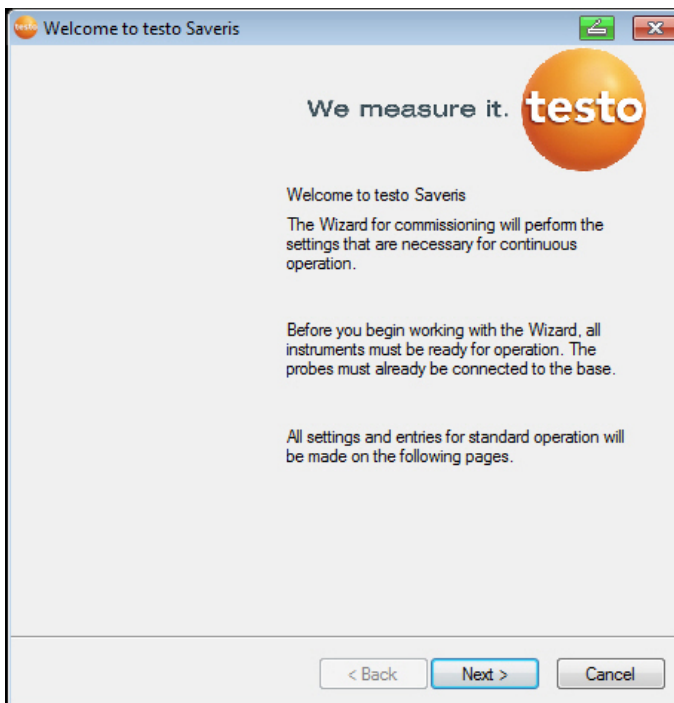

2. Click on **[Next >]**.
 - The **Commission new probe** dialogue is shown.

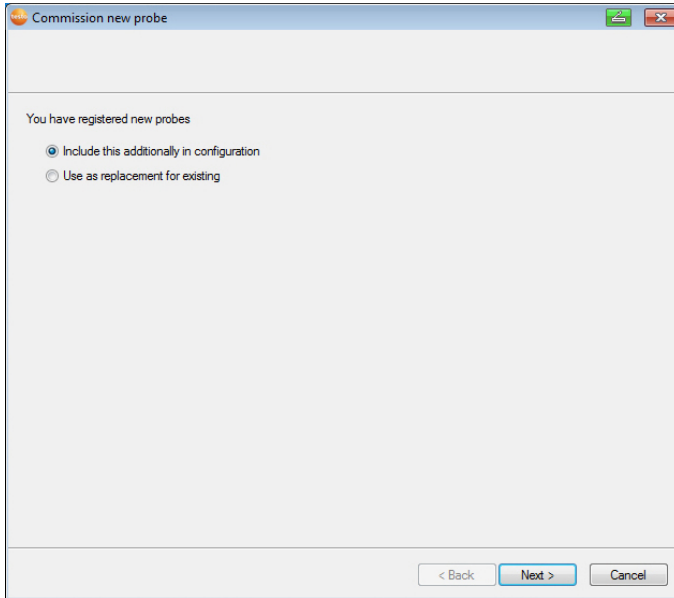

3. Leave default setting and click on **Next >**.



Analog couplers can always only be additionally included in the configuration and cannot be used as a replacement for ones that are already present.

- The **Scale** dialogue is displayed.

The screenshot shows a software window titled 'Scaling' with a standard Windows-style title bar. The main content area is titled 'Analog converter scaling' and contains a table with the following data:

Serial no.	Scaling	Display from	to	Unit	Decimal places
1730073	Voltage: 0.10 V	0.00	10.00	mA	3

Below the table are two buttons: 'User unit' and 'Totalizer setup'. At the bottom of the window are three buttons: '< Back', 'Next >', and 'Cancel'.

i The fields of the **Scale**, **Display from**, **to**, **Unit** and **Decimal places** columns are preassigned. These fields can be changed individually.

4. Select **Scale** (see type plate/transmitter operating instructions).
 5. Enter **Display from** and **to** (see type plate/transmitter operating instructions).
 6. Select **Unit**. If the desired unit is not available in the selection list: Add via **[User-defined unit]**.
 7. Select number of **Decimal places**.
 8. Click on **[Set up sum channel]** if the summation of a particular unit is required.
 9. Click on **[Next >]**.
- The list of the probes newly registered in the Saveris base is shown.

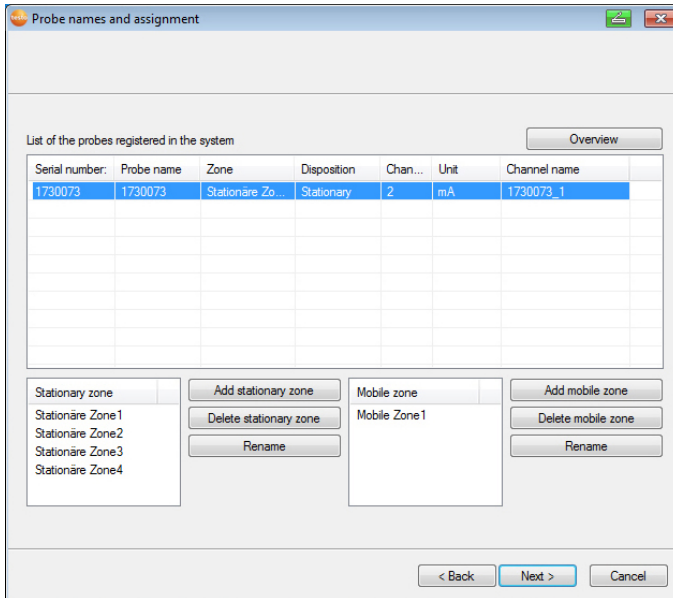

10. Click on **[New stationary zone]**.
11. Open the selection list via button  and select the zone to which the probe should be assigned.
12. Click on **[Next >]**.
13. Click in the **TE type** field and enter the thermocouple element type (**K**, **J**, **T** or **S**) if this information is necessary for the device.
14. If required, change the default values in fields **Probe name** and **Channel name**.



Assign channel names that are not longer than 20 characters.

15. If required, import adjustment data for the individual probes: Click on **[Import adjustment data]**.
16. Click on **[Next >]**.
 - The settings for the measuring cycle are displayed.

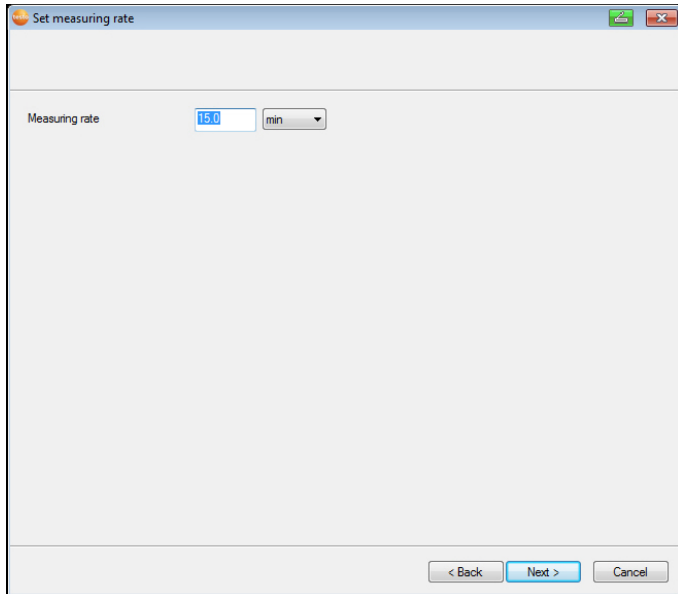

17. Enter **Measuring cycle** and define its **Unit**.



The measuring cycle determines the intervals at which a new measured value is saved in the Saveris base.

Possible settings for the unit:

- **sec** (second)
- **min** (minute)
- **h** (hour).

18. Click on **[Next >]**.

- If a router is registered on the Saveris base, the configuration of the connection type for the probes is shown.
If you have not registered a router, continue with step 24.

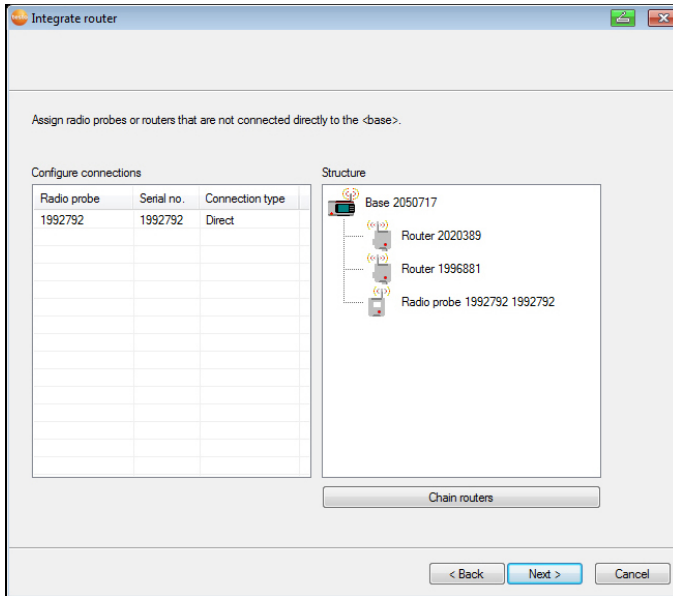

19. Click in the **Connection type** cell of the probe to be assigned to a router.

- The cell is shown as a selection list.

20. Use button  to open the selection list and select the router to which the probe should be assigned.

 Probes in a mobile zone cannot be assigned to a router.

21. Perform steps 21 and 22 for any other probes with measurement data to be transmitted to the Saveris base via a router.

22. Click on **[Next >]**.

- The wizard is displayed with the start of measurement configuration and the list of newly registered probes.

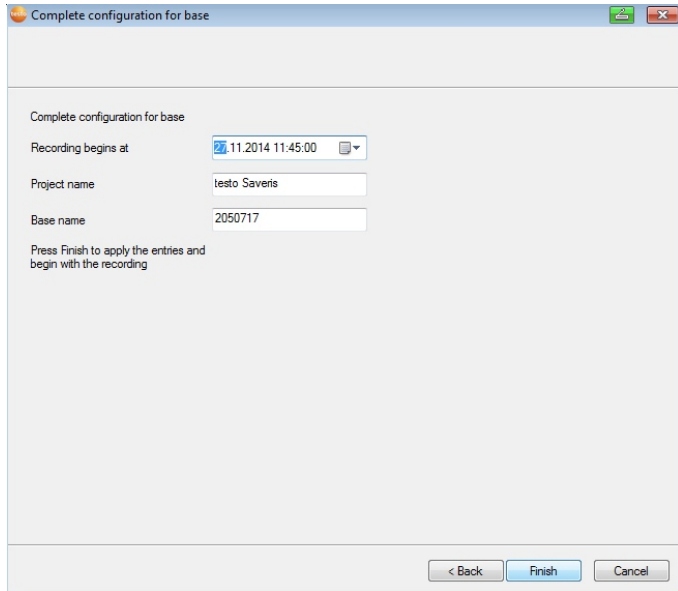

23. Postpone the start of measurement if necessary.
24. Click on **[Finish]** to end the hardware startup.
 - A message about the successful configuration of the hardware is displayed.
25. Confirm the message by clicking **[OK]**.
 - The new hardware is now ready to be used.



5.15. Performing the test run



The test run must be performed to ensure proper operation of the measuring system.

5.15.1. Checking system availability

i Wait for the first connection between the Saveris base and the probes to check the system availability.

- > Click in the navigation area on **System**.
 - In the data window, the following entries are displayed in the tree structure:
 - **Base**
 - **Radio probe**
 -  Radio probe assigned to a stationary zone.
 -  Radio probe assigned to a mobile zone.
 - **Ethernet probe**
 - **Router**
 - **Cockpit unit**
 - **Extender**
 - **Converter**.
-

i An asterisk (*) after a component indicates that the synchronisation of this component with the system is not yet complete (e.g. in the case of configuration changes).

1. Open **Radio probe**.
 - The active channels of the radio probes registered on the system are displayed.
 2. Click on a channel to open the settings and check the **Radio quality**.
- > Repeat step 2 for all other probes.
-

i If no values have accumulated for a probe for a while, check whether a connection exists between the probe and the Saveris base by briefly pressing the connect button at the probe. The LED at the probe shows the connection status; also see "**Meaning of the LED displays at the probes**".

5.15.2. Testing the system

For a simple system test:

- In the **System** main menu:
 - All probes are visible, synchronisation of the probes is complete (none have an asterisk * after their name)

- All components have the current firmware version
- Under operating data: the last probe data transfer was recently
- The communication statistics of the individual probes are good
- In the data view of the zones:
 - No noticeable alarms occurred during maintenance
 - In the diagram (selecting individual measuring points), the measuring point selections are regularly incorporated in the measuring cycle - without gaps.
- Generate and acknowledge at least one SMS or email alarm
- Wait for an automatic report or create it for test purposes under **Options** | **System test**
- No open alarms in the overview window
- Where there is regulated user access: authorised employees have access to the system in accordance with their authorisations
- In the **Tours**⁵ main menu:
 - Measured values and duration of tours carried out are displayed correctly.
 - From the data of the mobile zones, a tour blank can be generated via **[Define tour]**, which is displayed under **Tours**.
- At the Saveris cockpit unit:
 - All mobile zones and tour descriptions configured in the software can be selected in the Saveris cockpit unit under **Tour settings**.
 - When the tour is active, limit value violations are shown on the display and indicated via the red LED. They can be acknowledged on the Saveris cockpit unit.
 - Create test printout: All measured values are printed out in a 15-min cycle. Additional lines and signature line appear on the printout as defined in the software in the **System** main menu.



After a successful system test, a base backup is recommended, see Saving data in the Saveris base, page 182.

⁵ Only during mobile monitoring

5.16. Mounting the hardware

i The notes in chapter "Ensure safety" must absolutely be observed when mounting the Saveris components.

Do not mount the Saveris base and the probes at their locations until the measuring system functions as expected.

At sub-zero temperatures, the Li-ion rechargeable batteries in the base and in the Ethernet probes are not charged. Avoid assembly sites for these components with long-lasting, prevalent sub-zero temperatures.

After mounting, perform another test run of the system; also see "Performing the test run".

5.16.1. Mounting the Saveris base on the wall

i When selecting the location for the Saveris base, please take into account that this must be positioned close enough to the computer used and a possible power supply in accordance with the cabling provided.

i The mounting materials (screws, anchor plugs etc.) are not included in the delivery.

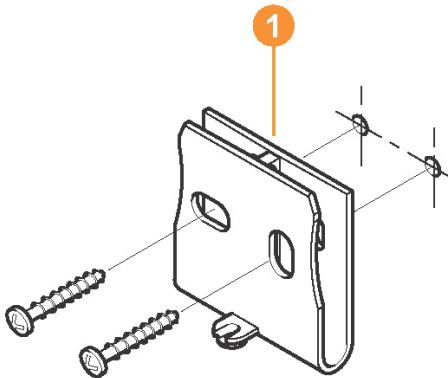

1. Position wall bracket **1** at the desired location.
2. Using a pen, mark the locations for the fastening screws.

i The distance between the fastening screws is 25 mm.

3. Prepare the fastening location for the attachment in accordance with the material (e.g. drill hole, insert anchor plug).
4. Fasten wall bracket using appropriate screws.

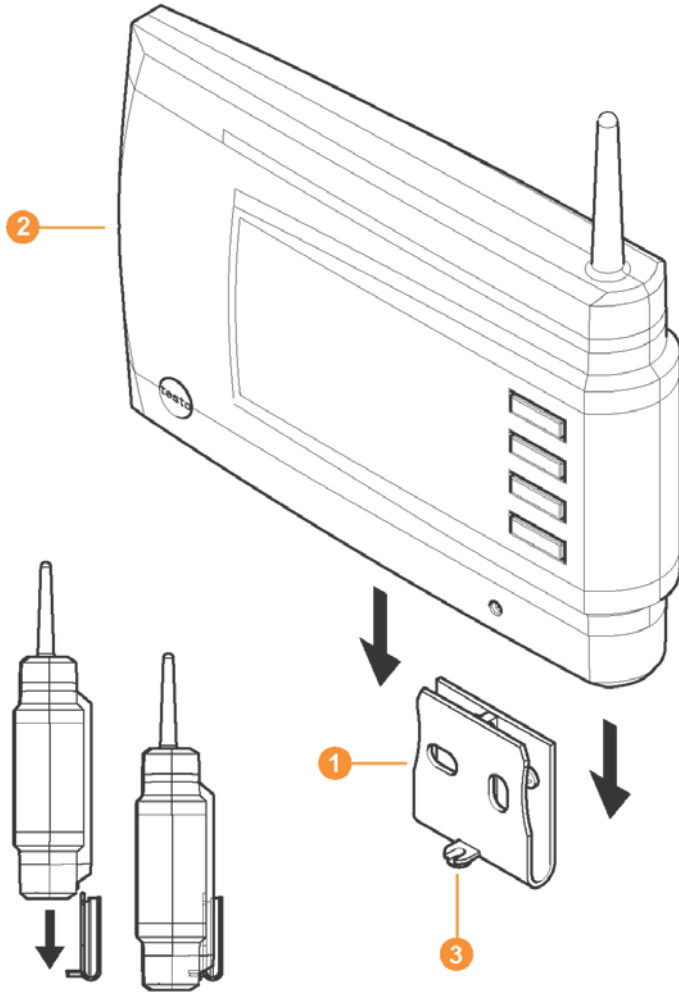

5. Place Saveris base **2** on the wall bracket **1** and secure with screw **3**.

5.16.2. Setting up Saveris base with stand

- i** When selecting the location for the Saveris base, take into account the following points:
- The Saveris base must stand on a level, non-slip surface.
 - The Saveris base must be positioned close enough to the computer used and a possible power supply in accordance with the cabling provided.

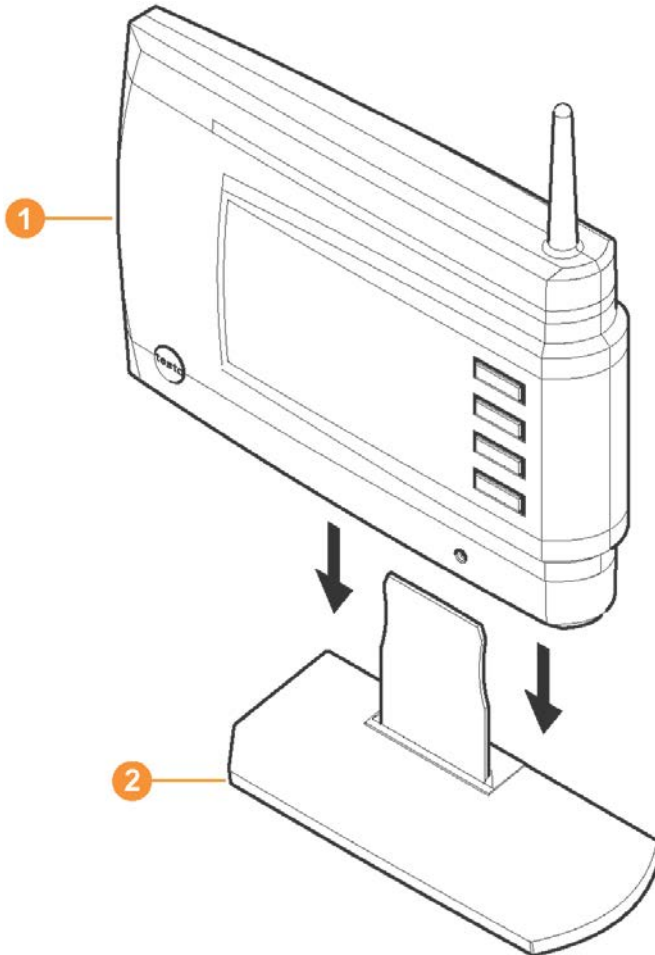

1. Place the Saveris base **1** on the stand **2**.
2. Set up the Saveris base at the desired location.

5.16.3. Mounting the probe on the wall

- i** When selecting the location, take into account the following points:
- The range of the probe may not be exceeded; see Performing the test run, page **98** and see Connecting radio probe, page **49**
 - Attach the probe in such a way that the readings cannot be distorted, e.g. by exposure to direct sunlight
-

- i** The mounting materials (screws, anchor plugs etc.) are not included in the delivery.
-

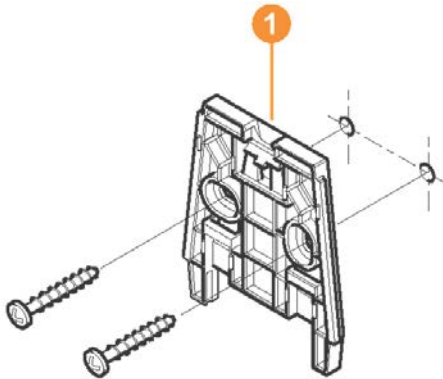

1. Position wall bracket **1** at the desired location.
 2. Using a pen, mark the locations for the fastening screws.
-

- i** The distance between the fastening screws is 30 mm.
-

3. Prepare the fastening location for the attachment in accordance with the material (e.g. drill hole, insert anchor plug).
 4. Fasten wall bracket using appropriate screws.
-

- i** The wall bracket must be screwed down with the smooth surface facing the wall.
-

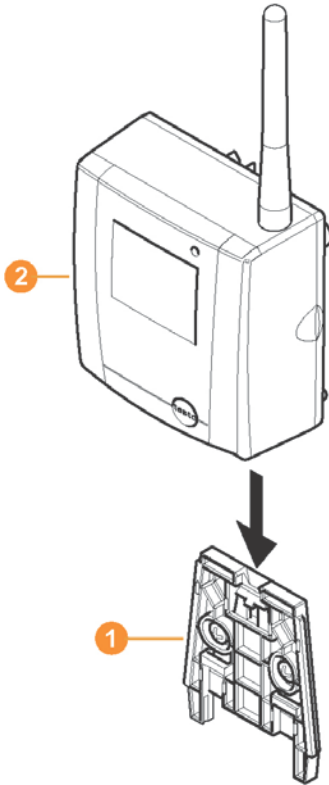

5. Place probe **2** on the wall bracket **1** until it engages.

i Please refer to "Removing probe from wall bracket" for removing the probe from the wall bracket.

i The radio probes T1/T1D/T2/T2D can be protected with the Saveris protective housing (article no. 0572 0200) against impact or prepared for high-pressure cleaning.

The two halves of the protective housing are force fitted together, even if the coupling has already been loosened. To loosen it, use a screwdriver to carefully unscrew the external screws. Do not damage the surrounding seal.

When assembling the Saveris protective housing, the screws must be tightened and the unassigned connections must be sealed with the supplied plug to ensure IP protection to IP 69 K.

5.16.4. Checking the measuring system again

- > Perform another test run at the measuring system; see "Performing the test run".

i After mounting the hardware, perform another check of the system to test the proper function of the measuring system.

You can thus recognize whether probes are located outside of the range of the Saveris base, where applicable, or the radio link is interfered with by structural conditions.





6 Using the product

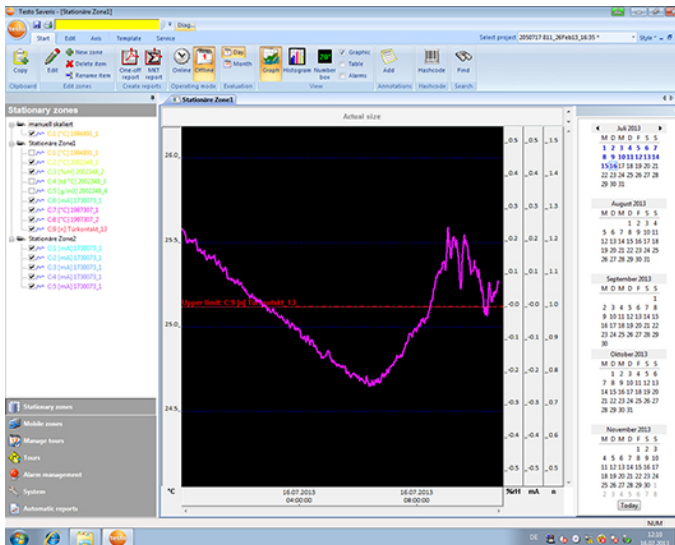

6.1. User interface

In this chapter, you learn how the user interface of the Saveris software is designed.



1 Menu bar

Menu	Explanation
	All functions that you require to open, close, save and print. The recently used files are also available as a list for opening. Using this menu, the program can also be ended.
	With the Send command, you can send out measuring results by email.
	Saves the current selection in a file.
	Prints the current view.

Menu	Explanation
	Visualised base LED as an alarm status display in the software: no alarm (green), main alarm (flashing red), warning (flashing orange), system alarm (flashing yellow).
	Setting options for the menu bar.
Start	Menu bar, includes functions for the clipboard, for editing the zones, evaluation, and display in the tables and diagrams.
Edit	Functions for evaluating the diagrams or tables and possible settings for the curves and axes in the diagram view.
Template	Selection of the report heads and editing functions for the templates
Service Extras	Display of service data (e.g. version number of the software)
Select project	Selection of all projects already created.

2 Data range

The measurement data are managed in the data range. You can create new groups of readings and copy the data from individual channels within the groups.

3 Display range

In the display range, the readings are represented as diagrams and tables and the alarms received are listed.

The data from several series of measurements can be opened and you can switch between them via the tab.

4 Calendar and acknowledging alarms

In offline mode (see **Start | Operating mode**, page 110) the calendar is shown that is used for quick navigation within the data records. Open the data records in the display range by clicking on a certain day in the calendar or marking a period of several days in the calendar with the mouse button pressed.

In the online mode, this range shows the alarm acknowledgement in which you confirm the alarms received.

- 5 **Navigation area**
In the navigation area, change to
 - the display of **Data** and
 - the settings for the **Alarms**, the **System** and the **Reports**.
- 6 **Status bar**
Shows the status information for the software.

6.2. Menus and commands

In this chapter, you learn which menus and commands are available to you and what you can use these commands for.

6.2.1. Start

Start | Clipboard menu

Menu function	Description
Copy	Copies the marked element onto the clipboard.

Menu Start | Edit zones

Menu function	Description
Edit zone	Changes the allocation of the channels to the selected zone.
New zone	Creates a new measured value group.
Delete	Deletes the selected element.
Rename	Renames the selected zone.

Menu Start | Create reports

Menu function	Description
One-off report	Define report contents and create a one-off report.
MKT report	Generates a retroactive MKT (Mean Kinetic Temperature) calculation as a PDF report for the selected zone. Report centre, channels and activation energy can be selected.

Start | Operating mode menu

Menu function	Description
Online	The measurement is performed at the same time, meaning that the data are automatically updated. In the online mode, a time period can be selected using the calendar.
Offline	The measurement is performed later, meaning that the data are not automatically updated. The data will not be called up by the base until you work actively in the software, e.g. when changing the view or opening another group.

Start | Evaluation menu

Menu function	Description
Day	Shows the calendar for the selection of the day in order to call up the data from the corresponding day or days from the database.
Month	Shows the calendar for the selection of the month in order to call up the data from the corresponding month from the database.

Start | View menu

Menu function	Description
Graph	Shows the graphic display of the readings if the checkbox is activated.
Table	Shows the tabular display of the readings if the checkbox is activated.
Alarms	Shows the list of the triggered alarms if the checkbox is activated.
Diagram	Option for the graphic display. The readings are shown as a diagram.
Histogram	Option for the graphic display. The current reading is shown as a column.

Menu function	Description
Monitor	Option for the graphic display. The readings are shown in fields that you can position freely on a wallpaper.

Start | Annotations menu

Menu function	Description
Paste	Adds a free comment text to a desired channel at a point in time that can be selected. The note is visible in the Graphics view as a yellow icon and in the Table view as a red triangle in the table cell. The entered comment text appears when the mouse rolls over it. The comment can be edited and deleted via the context menu.

Menu Start | Hash code

Menu function	Description
Hash code	Display the hash values of the readings.

Start | Search menu

Menu function	Description
Search	Opens a search window in the Data and System navigation areas in which zones and channels can be searched through via textual word search.

6.2.2. Edit

Editing in the diagram view

The **Edit** menu (diagram) is only displayed if the diagram has been activated by clicking into the window.

Menu **Edit** | **Tools** (diagram)

Menu function	Description
Zoom in	<p>Drag to form a rectangle in the diagram window to zoom in on the highlighted area. This function can also be used during a measurement in online mode. In the process, however, the extract shown always displays the current value.</p> <p>When you click on [Original size], the diagram is once again displayed in its overall size.</p>
Crosshairs	<p>Crosshairs with which the curve can be followed are shown by clicking on a point of the measurement curve. The date, time, measured value number and measured value are shown in the process.</p>
Regression curve	<p>Regression curves are an aid to enable you to better assess large, unclear amounts of data. In this process, "outliers" are suppressed and the actual course of the curve is reproduced using a theoretical, mathematical function.</p> <p>The regression curve is shown by clicking on a measurement curve. The regression coefficients are shown in the status bar.</p>
Limit values	<p>Activate the checkbox to show the limit values in the diagram.</p>

Menu Edit | Font

Menu function	Description
Font	Opens the selection list of available fonts.
Font size	Opens the selection list of available font sizes.

Menu Edit | Curves (diagram)

Menu function	Description
C:1, C:n	Legend for the diagram. Click on the entry of a curve and the dialogue box for the characteristics of the curve is opened.

Edit in the table view

The **Edit** (table) menu is only shown if the table is activated by clicking in the window.

Menu Edit | Formulae (table)

Menu function	Description
New formula	Opens an input window for entering a new calculation formula.
Edit formula	Allows an existing formula to be edited.
Drop a formula	Deletes an existing formula.

Edit | Tools (table) menu

Menu function	Description
Mark	Mark data over a definable time period or definable lines (index range).
Drop marking	Drops the marking.
Extra lines (minimum, maximum, mean value)	<p>Inserts a row with the corresponding value for the overall table at the end of the table.</p> <p> The min, max and average values cannot be calculated via a period/index range defined in the table.</p>
Compress	Compresses the table to definable intervals. Only the first and the last value are shown for the individual intervals. The other readings are hidden.
Drop compression	Drops the compression.

Menu Edit | Font

Menu function	Description
Font	Opens the selection list of available fonts.
Font size	Opens the selection list of available font sizes.

Edit | Find (table) menu

Menu function	Description
Minimum	Shows the smallest reading of the selected channel within the table.

Menu function	Description
Maximum	Shows the largest reading of the selected channel within the table.

Editing in the monitor view

The **Edit** (monitor) menu is only shown if the diagram window is activated by clicking in the window.

Edit | Tools (monitor) menu

Menu function	Description
Wallpaper	<p>Opens the Open dialogue box to select the wallpaper for the monitor. The following image formats can be added: .bmp, .jpg, .wmf, .ico and .gif.</p> <hr/> <p> The background image must be stored locally on the PC.</p>
Background colour	Opens the Colour dialogue for selecting the background colour for the number field.
Broadband, Filling Frame	<p>Settings for adapting the wallpaper to the number field:</p> <ul style="list-style-type: none"> • Broadband: the image size is adjusted to the width and height of the window and the picture is positioned centred in the window. The ratio of image height to image width is retained here. • Filling Frame: the picture is stretched so that it fills the entire window.
Rearrange	Resets the arrangement of the number fields.
Edit Background Image	The background image can be edited with Microsoft® Paint.
Delete Background Image	Deletes the currently displayed background image.

Menu Edit | Shapes (monitor)

Menu function	Description
Insert	Insert arrows and text fields.
Delete	Deletes a selected element.
Colour	Colour setting for a selected element.
Undo	Resets the latest changes.

i You can adapt the number fields to your wishes using the right mouse button. You can thus show or hide their frames or their transparency, for example.
You can move the fields with the left mouse button and change their size.

6.2.3. Axes

Menu Axes | Axes

In this menu you can configure the value and time axis.

Menu Axes | Value axis

Menu function	Description
Division	Input of upper and lower limits and division adjustment (finer/coarser).

Menu Axes | Time axis

Menu function	Description
Division	Division adjustment (finer/coarser).

6.2.4. Template

Template | Template menu

Select a standard template in this menu into which the data that are to be saved or printed are integrated.

The templates differ in the protocol header, meaning in the company logo, the address field or the specification of statistical values.

Template | Edit menu

Menu function	Description
---------------	-------------

Edit template	Enables the editing of an existing template.
Create new template	Enables the creation of a new template.

6.2.5. Service

Menu **Service** | **Service**

This menu can be used to display the service data.

Menu function	Description
Display service data	Creates a *.html file incorporating the service data.
	 The software version number can be found among the service data.

6.2.6. Selecting projects

The project data for all projects already created can be displayed using the selection menu without having to restart the software.

6.2.7. Style template

Selection of the colour scheme for the program window.

6.3. Creating, editing and deleting zones

After you have familiarized yourself with the menus of the Saveris software, you can now turn to creating zones, for example to separate the probes according to location. You could perhaps combine probes that are located in store rooms into one zone and probes that are in cold rooms into another.

 Changing or deleting zones during operation will affect subsequent generation of PDF reports. As these changes also apply retroactively, old zone configuration data is overwritten.

If a PDF report is generated retroactively from the past, only the most recent zone configuration is used for report generation. Without a database backup, complete retraceability of the changed or deleted zones cannot be guaranteed.

The assignment of radio probes to zones is carried out in the startup wizard. This can be changed later on via **Start** | **Edit**.

-
- i** You can assign a maximum of 4 radio probes to one mobile zone and monitor max. 2 mobile zones simultaneously in one tour.
-

6.3.1. Creating zones

1. In the navigation area, click on **Stationary zones** or **Mobile zones**.
 - In the data area, the available zones are displayed.
2. In the **Start | Edit zones** menu, select the command **New zone**.
 - The **New zone** dialogue box is displayed.
3. If required, deactivate any unneeded channels.

-
- i** At least one channel must be activated.
In mobile zones, all channels of a probe must be assigned to the same zone.
-

4. In the **Name** field, enter the name of the new zone.

-
- i** Assign names for the zones that are not longer than 15 characters.
-

5. Confirm entries with **[OK]**.
 - The **New zone** dialogue box is closed and the new zone is listed in the tree structure in the data area.

6.3.2. Changing zones

You can add channels to an existing zone. You can delete channels that you no longer require in a zone from this zone. You can also change the name of the zone.

1. In the navigation area, click on **Stationary zones** or **Mobile zones**.
 - In the data area, the available zones are displayed.
2. In the tree structure of the data area, select the zone that should be changed.
3. In the **Start | Edit zones** menu, select the command **Change zone**.
 - The **Change zone** window opens.
4. Click on the checkboxes in front of the channels that are to be added to the zone or deactivate them to remove the channel from the zone.
5. In the **Name** field, overwrite the zone name.
6. Confirm the input with **[OK]**.

6.3.3. Deleting zones

1. In the navigation area, click on **Stationary zones** or **Mobile zones**.
 - In the data area, the available zones are displayed.
2. In the tree structure, select the zone that should be deleted.
3. In the **Start | Edit zones** menu, select the command **Delete**.
 - After confirmation, the zone is deleted.

i In the database, the zone is marked as deleted and disabled, but not deleted. A disabled zone is only visible in the period in which it was active.

6.3.4. Assigning zones

You can limit zone access to certain users and user groups. Multiple selection is also possible.

i Zones are visible to all users as standard.

✓ Users or user groups can be created in the Active Directory.

1. In the navigation area click on **System**.
2. In the **System | Security** menu, select the command **Authorisations**.
3. Select zone for which access should be limited.
 - The **Authorisations** window opens.
4. Click on **[Search]**.
 - The **Search** window listing the users or user groups from the Active Directory opens.
5. Select users or user groups that should have access to the selected zone.
6. Confirm the input with **[OK]**.
 - In the **Authorisations** window, the selected users are assigned to the relevant zone.
7. Click on **OK**.

6.4. Setting up tours

6.4.1. Tour description

1. In the navigation area, click on **Tour administration**.
 - In the data area, the dialogue box for **Tour description** is displayed.

The screenshot shows a dialog box titled "Tour description". At the top left is a button labeled "Add tour description". The main content area is divided into two sections. On the left is a large, empty text input field. On the right, there are five vertically stacked input fields, each with a label to its left: "Driver", "Driver's mobile phone", "Recipient", "Goods", and "Comments". At the bottom of the dialog is a button labeled "Apply settings".

2. Select **[New tour description]**.
3. Enter the name of the new tour description. The name appears in the tour calendar and in the Saveris cockpit unit.
4. Enter information.
5. Exit dialogue box.
 - Query appears asking whether information should be saved.
6. Click **[Yes]**.
 - The tour description is saved and can be added to a tour during tour planning. The tour description is transferred to the Saveris cockpit unit and can be selected.



The Saveris cockpit unit can manage up to 100 tour descriptions.

6.4.2. Planning tours

i This description only relates to tours that are planned for the future. For this, a tour is created via the software. This is recommended if no Saveris cockpit unit is used for tour entry.

1. In the navigation area, click on **Tour administration**.
 - In the data area, the dialogue box for **Plan tour** is displayed.

The screenshot shows a software interface for planning tours. The main window is titled "Tour planning" and has two tabs: "Add tour" and "From description". The "Add tour" tab is active. On the left side of the "Add tour" tab is a large, empty rectangular area. On the right side, there is a form with several input fields: "Driver", "Driver's mobile phone", "Recipient", "Goods", and "Comments". Below these fields is a "Mobile zone" dropdown menu currently showing "Mobile Zone1". Underneath the dropdown is a checkbox labeled "2. mobile zone". At the bottom of the form are two radio buttons: "Single" and "Recurring". At the bottom left of the dialog box is an "Apply settings" button.

2. Select **[New tour card]**.
3. Enter the name of the new tour. The name appears in the tour calendar and in the Saveris cockpit unit.
4. Select mobile zones.
 - > If required: Add tour description.
5. Select period during which the tour should be carried out.

6. Exit dialogue box.
 - Query appears asking whether information should be saved.
7. Click **[Yes]**.
 - The tour is saved and is displayed in the tour calendar as a planned tour.



Tours that have not yet taken place can only be changed in the **Tour administration** navigation area.

6.4.3. Defining tours



This function is used to subsequently assign existing measurement data to tours.

1. In the navigation area, click on **Mobile zones**.
2. Select **Define tour**.
 - The **Define tour** window is opened.
3. Define required tour. Via **[From tour description]**, the additional information for a created tour description can be transferred for this tour.
4. Confirm entries with **[Finish]**.
 - Tour is saved and displayed in the tour calendar.

6.4.4. Displaying tours

1. In the navigation area, click on **Tour administration**.
2. Select **Tour calendar**.

The screenshot shows the 'Tour calendar' interface. On the left, there are filters for 'All mobile zones', frequency (Daily, Weekly, Monthly), and status (Planned, Completed). A calendar widget shows the current month (July 2012) and the next month (August 2012). The main area is a grid with columns for days of the week (Mo, Tu, We, Th, Fr, Sa, Su) and rows for time slots from 00:00 to 23:00 in 30-minute increments. The grid cells are yellow, and the header row is grey.

	Mo, 2. Jul	Tu, 3. Jul	We, 4. Jul	Th, 5. Jul	Fr, 6. Jul	Sa, 7. Jul	Su, 8. Jul
00:00							
01:00							
02:00							
03:00							
04:00							
05:00							
06:00							
07:00							
08:00							
09:00							
10:00							
11:00							
12:00							
13:00							
14:00							
15:00							
16:00							
17:00							
18:00							
19:00							
20:00							
21:00							
22:00							
23:00							

4. Click on **[Search]**.
 - Results are displayed.
5. Select required entry from the list of results.
6. Click on **[Display]**.
 - Selected tour data is displayed in the **Tour management** navigation area.

6.4.6. Changing tours

1. In the navigation area, click on **Tours Management**.
2. Select **Change tour**.
 - The **Define tour** window is opened.
3. Make required changes.
4. Click on **[Next]** and **[Finish]**.
 - Tour is changed.

6.5. Configuring the alarms

Information on the alarm function

- The alarms occurring in the Saveris system are primarily used to notify the user in good time that problems have occurred which jeopardise the continuous availability of the data on the database. Generally, action is required.
- Alarms indicate a one-off, but possibly also regular, malfunction. The aim must be to minimise the number of alarms that occur during operation and eliminate such alarms wherever possible. There may be max. 200 outstanding, unacknowledged alarms at any one time. An increasing number of unacknowledged alarms not only make troubleshooting in serious cases more difficult, but also slow the system response during

The configuration of the alarms is performed in four steps:

1. Set up the base alarms
Configuring the system alarms determines the conditions under which the base triggers an alarm.
2. Set up alarm groups.
With the alarm groups, you determine for which probes and under what conditions an alarm is triggered for system alarms and for channel-related alarms.
3. Enter recipient.
You must enter the recipients to be able to send alarm messages by SMS or e-mail.
4. Define rules.

With the rules, you determine which employee should be notified if an alarm is triggered in a group and which employee receives a message if the alarm is not acknowledged.

i As the probes that monitor the mobile units are not generally operated under target conditions (e.g. HGV is not cooled during idle periods), limit values are only relevant according to the tour blank. The Saveris base therefore only outputs system alarms for probes in mobile zones – limit value breaches are suppressed.

6.5.1. Setting up base alarms

i Any configuration changes are only transferred to the probe/base once you have exited the **Alarm management** menu!
You should therefore exit the **Alarm management** menu after editing.

6.5.1.1. Setting up alarms

1. Click on **Alarm management** in the navigation area.
 - The data area shows the sub-menus **Base alarm settings**, **Component alarm settings**, **Channel alarm settings**, **Alarm recipients**, **Alarm rules**, **Comments for acknowledging alarms**.
2. Click on **Base alarm settings**.
 - The **Base alarm settings** are shown in the display area.

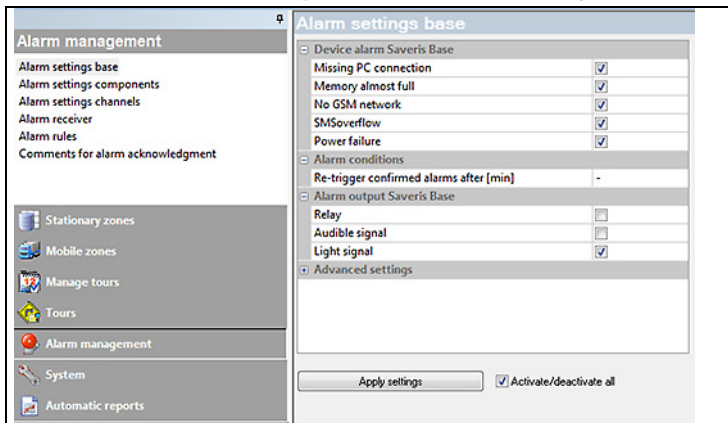

Display	Explanation
Device alarm Saveris Base	Setting options for the base alarms Missing PC connection: no response from the PC Memory almost full: alarm when the base memory overflows. No GSM network: alarm when there is no GSM connection. SMS overflow: alarm when an error occurs in SMS transmission. Power failure: alarm when the base power supply fails.
Alarm conditions	Re-trigger confirmed alarms after [min]: re-triggers alarms that have already been acknowledged following a specified duration.
Alarm output Saveris Base	Relay Audible signal Light signal
Advanced settings	Radio interference (stationary) [min] Network interference [min] Radio interference (mobile) [h]
Apply settings	Saves the alarm settings.
Activate/deactivate all	Activates all available alarm settings.
Activate scheduling	Activates the configured scheduling.
Alarms scheduling	Opens a window for configuring the scheduling.

3. Carry out alarm settings for the base.
4. Click on **Apply Entries**.
5. Exit Alarm Management menu.
 - Alarm settings are transferred to the devices.

6.5.1.2. Configuring scheduling

i All alarms across the entire system are paused/activated via scheduling.

1. Click on **Activate scheduling**.
 - The **Alarms scheduling** button is activated.
2. Click on **Alarms scheduling**.
 - An input window with a complete scheduling system is displayed. The scheduling is filled out from Monday to Sunday 0:00 – 24:00 ex-works.
3. Click on a time entry with the right mouse button and select **Delete**.
 - The selected time entry is deleted.
4. Click on the blank time entry with the right mouse button and select **New**.
 - An input window is displayed, enter the alarm ON times (from, to or all-day) here.

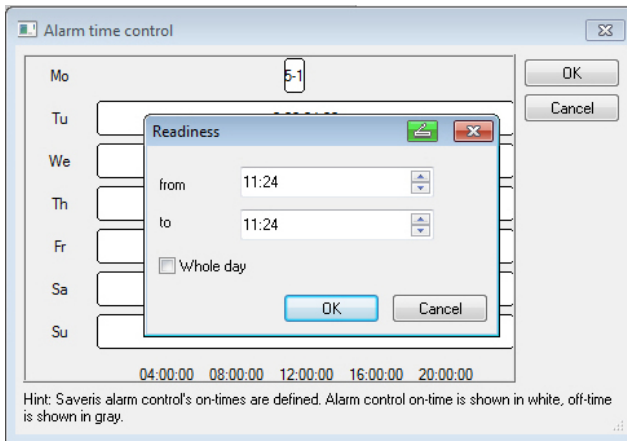

5. Click on **OK** to confirm the entry.
 - The input window is closed, the modified times are displayed in the scheduling overview.
 - In order to create a second time entry for the same day, repeat step 4 and step 5. Two time periods can be specified per day.
6. Press **OK** to confirm.
 - The input window is closed, the modifications to the scheduling are accepted.

6.5.2. Setting up alarm groups

6.5.2.1. Components

i Any configuration changes are only transferred to the probe/base once you have exited the **Alarm management** menu!
You should therefore exit the **Alarm management** menu after editing.

1. Click on **Alarm management** in the navigation area.
 - The data area shows the sub-menus **Base alarm settings**, **Component alarm settings**, **Channel alarm settings**, **Alarm recipients**, **Alarm rules**, **Comments for acknowledging alarms**.
2. Click on **Component alarm settings**.
 - The probe alarm settings are shown in the display area.

Component	Serial number	Name	Alarm group components
Ethernet probe	1730073	1730073	
Radio probe	1992792	1992792	
Radio probe	1994991	1994991	
Router	1996881	1996881	Komponentengp14
Radio probe	1997307	1997307	
Radio probe	2002348	2002348	
Router	2020389	2020389	

Designation	Description
[Insert into new group]	Creates a new alarm group.
[Move to]	Move components/channel to another alarm group.
[Remove from group]	Removes the components/channel from the specified alarm group.

Designation	Description
[Delete this group]	Deletes the entire alarm group.
[Apply to all]	Applies an alarm group to all components/channels.
Component list	List of the available components and their affiliation to the selected alarm group.
Group alarm settings	Enter the group name.
System settings	<p>Output of system alarms: alarm activation for notification when there is a connection problem, LoBat and power failure</p> <p>Alarm conditions: trigger acknowledged alarms after [min]</p> <p>Alarm output Saveris Base: settings for relays, audible signal and light signal.</p>
[Apply entries]	Saves the alarm settings of an alarm group.
Activate/deactivate all	Activates all available alarm settings.

Creating a new group

1. Right-click on component, then click on **[Insert into new group]**.
 - A new alarm group is created.
2. Overwrite the default names in **Group alarm settings**.

Move to...

1. Right-click on component, then click on **[Move to ...]**.
 - A selection of available alarm groups is displayed.
2. Click on required alarm group.
 - The component is assigned to the selected alarm group.

Remove from group

1. Right-click on component, then click on **[Remove from group]**.
 - The component is removed from the assigned alarm group.

Delete group

1. Right-click on component, then click on **[Delete this group]**.
 - The assigned alarm group is deleted, all components that were assigned to this group are now without an alarm group.

Apply to all

1. Right-click on component, then click on **[Apply to all]**.
 - The alarm group assigned to this component is applied to all other components.

6.5.2.2. Channels



Any configuration changes are only transferred to the probe/base once you have exited the **Alarm management** menu!

You should therefore exit the **Alarm management** menu after editing.

1. Click on **Alarm management** in the navigation area.
 - The data area shows the sub-menus **Base alarm settings**, **Component alarm settings**, **Channel alarm settings**, **Alarm recipients**, **Alarm rules**, **Comments for acknowledging alarms**.
2. Click on **Channel alarm settings**.
 - The probe alarm settings are shown in the display area.

The screenshot shows the 'Alarm management' interface. On the left is a navigation menu with options: Stationary zones, Mobile zones, Manage tours, Tours, Alarm management (selected), System, and Automatic reports. The main area displays a table titled 'Alarm settings channels' with the following data:

Serial number	Name	Alarm group	Warnings	Alarm group ...	In Zone(s)
1730073_2	1730073_1				Stationaire Zone1
1992792_1	1992792_1				Mobile Zone1
1994891_1	1994891_1				Stationaire Zone1,manuel sk...
1997307_1	1997307_1				Stationaire Zone1
1997307_2	1997307_2		Wamgpg8	Trendgpg6	Stationaire Zone1
1997307_3	TataviesH...	Alarmgp13		Trend_Sr	Stationaire Zone1
2002348_1	2002348_1				Stationaire Zone1
2002348_2	2002348_2				Stationaire Zone1
2002348_3	2002348_3				Stationaire Zone1
2002348_4	2002348_4				Stationaire Zone1

At the bottom of the table area, there are two buttons: 'Apply settings' and 'Print'.

Designation	Description
[Insert into new group]	<p>Creates a new alarm group, with a distinction between alarm, warning and trend alarm group.</p> <p>i A trend alarm is used to monitor temporal changes or the stability of measurement parameters. The change in the measurement parameter is determined over four measurement cycles and projected onto the change per hour. To this end an alarm is useful unless the absolute value of the measurement parameter is supposed to be within specified limits, but rapid changes must be avoided.</p>
[Move to]	Move components/channel to another alarm group.
[Remove from group]	Removes the components/channel from the specified alarm group.
[Delete this group]	Deletes the entire alarm group.
[Apply to all]	Applies an alarm group to all components/channels.
Channel list	List of the available channels and their affiliation to the selected alarm group.
Group alarm settings	Enter the group name.
System settings	<p>Alarm conditions: settings for lower limit delay [Measurements], upper limit delay [Measurements] and trigger acknowledged alarms after [min]</p> <p>Alarm output Saveris Base: settings for relays, audible signal and light signal.</p>
[Apply entries]	Saves the alarm settings of an alarm group.
[Print]	Creates a file containing a summary of the alarm settings for probes and the base.

Designation	Description
Activate/deactivate all	Activates all available alarm settings.

Creating a new group

1. Right-click on component, then click on **[Insert into new group]**.
 - A new alarm group is created.
2. Overwrite the default names in **Group alarm settings Group selection list**.

Move to...

1. Right-click on component, then click on **[Move to ...]**.
 - A selection of available alarm groups is displayed.
2. Click on required alarm group.
 - The component is assigned to the selected alarm group.

Remove from group

1. Right-click on component, then click on **[Remove from group]**.
 - The component is removed from the assigned alarm group.

Delete group

1. Right-click on component, then click on **[Delete this group]**.
 - The assigned alarm group is deleted, all components that were assigned to this group are now without an alarm group.

Apply to all

1. Right-click on component, then click on **[Apply to all]**.
 - The alarm group assigned to this component is applied to all other components.

6.5.3. Creating recipient



Any configuration changes are only transferred to the probe/base once you have exited the **Alarm Management** menu!

You should therefore exit the **Alarm Management** menu after editing.

1. Click on **Alarm Management** in the navigation area.
 - The data area shows the sub-menus **Base alarm settings**, **Component alarm settings**, **Channel alarm settings**, **Alarm recipients**, **Alarm rules**, **Comments for acknowledging alarms**.

2. Click on **Alarm recipients**.

- The recipient data are shown in the display range.

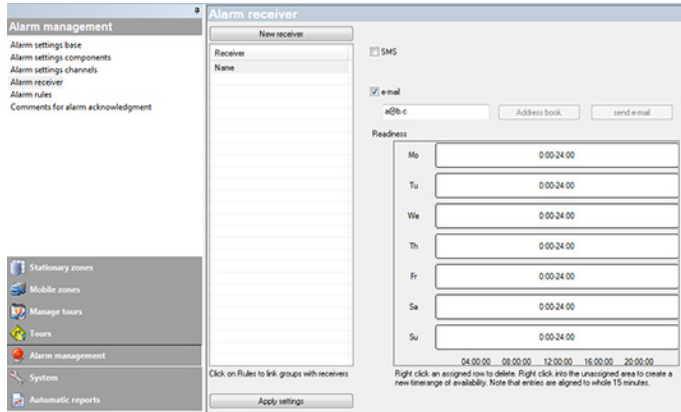

Designation	Description
[New receiver]	Creates a new entry in the receiver list.
Receiver list	List of possible recipients. <div style="display: flex; align-items: flex-start;"> <div style="font-size: 2em; margin-right: 10px;">i</div> <div> <p>The telephone number in the receiver list comes from the commissioning.</p> <p>You can replace the number with a recipient name by clicking on the number with the right mouse button and selecting the Rename command in the context menu.</p> </div> </div>
SMS/e-mail checkbox	Specification as to whether the alarm message should be sent by SMS or e-mail.
Input field for SMS function	Number to which the SMS should be sent.
Input field for e-mail function	E-mail address of the recipient.
Readiness	Overview of the availability times of the recipient.

Designation	Description
	<p>i Time entries are automatically rounded up/down to 1/4 hour.</p> <p>To change the availability time, you must delete the existing entry using the right mouse button and enter a new availability time.</p>

Creating new recipient

1. Click on **[New receiver]**.
 - A new entry with an identical designation is added to the receiver list.

i If no recipient was defined with clear text beforehand, the telephone number is used alternatively as the recipient name.

2. Click on the new entry in the receiver list with the right mouse button and change the designation.

Mobile phone data of the recipient (optional)

1. Activate the **SMS** checkbox if the recipient should be informed by SMS when an alarm is triggered.
 - The input field for the telephone number is shown.
2. Enter the corresponding numbers.

i If an alarm chain is to be created from several recipients, the output targets (SMS or e-mail) of the recipients may not vary within the respective alarm chain.

Entering e-mail address of the recipient (optional)

1. Activate the **e-mail** checkbox if the recipient should be informed by e-mail when an alarm is triggered.
 - The input field for the e-mail address is shown.
2. Enter the e-mail address of the recipient.

i If an alarm chain is to be created from several recipients, the output targets (SMS or e-mail) of the recipients may not vary within the respective alarm chain.

Transferring alarm settings

1. Exit "Alarm Management" menu.
 - Alarm settings are transferred to the devices.

6.5.4. Creating alarm rules

- i** Any configuration changes are only transferred to the probe/base once you have exited the **Alarm Management** menu!
You should therefore exit the **Alarm Management** menu after editing.

A prerequisite for the creation of the alarm rules is that the base alarm settings, the probe alarm groups and the recipients of the alarm messages have been entered.

- Click on **Alarm Management** in the navigation area.
 - The data area shows the sub-menus **Base alarm settings**, **Component alarm settings**, **Channel alarm settings**, **Alarm recipients**, **Alarm rules**, **Comments for acknowledging alarms**.
- Click on **Alarm Rules**.
 - A list of the previously created alarm rules is shown in the display range.

The screenshot shows the 'Alarm management' sidebar on the left with 'Alarm rules' selected. The main area displays the 'Alarm rules' table with columns: Group, Receiver, Message, Forward to, to 2nd receiver, Forward to, and to 3rd receiver. The first row shows '_Base', 'Name', an empty 'Message' field, and '5' in the 'Forward to' column. Below the table is a 'New rule...' button and a preview of scheduled messages for days 15 to 21, with time slots from 00:00 to 22:00.

Designation	Description
Group	Group for which the alarm rules apply.
Receiver	Recipient who is to receive the alarm message.
Message	Text of the alarm message.

Designation	Description
Forward to	Time interval after which the alarm message should be sent to another recipient if the first recipient does not acknowledge the alarm.
to 2nd receiver	Recipient who is to receive the forwarded alarm message if the first recipient does not acknowledge the alarm.
Forward to	Time interval since the last alarm after which the alarm message should be resent to another recipient if the alarm was not acknowledged. Recipient 3 receives alarm after (forwarding time from recipient 1 to 2 + forwarding time from recipient 2 to 3) min.
to 3rd receiver	Recipient who is to receive the forwarded alarm message if the alarm was not acknowledged.
[New rule...]	Starts the wizard for creating a new alarm rule.
Preview	Shows the configured scheduled messages.

Creating new rule

1. Click on **[New rule...]**.
 - The wizard for creating a new rule is started.

2. Determine the group in the **With alarm in group** selection list for which the new alarm rule should apply.
3. Enter the text of the alarm message in the **Message** input field.

4. Determine the first receiver who is to receive the alarm message in the selection list of the same name.
5. Click on **[Continue >]**.
 - The dialogue for the forwarding function or for finishing the alarm rule is shown.

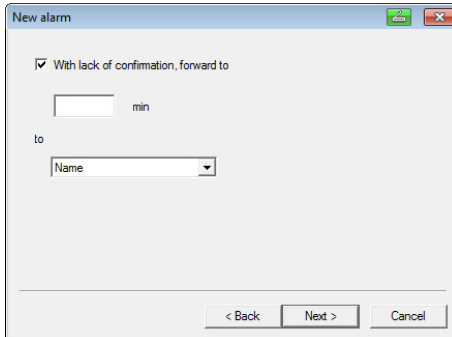

6. Either
 - click on **[Finish]** if the alarm message should not be forwarded if the first recipient does not acknowledge the alarm or **[Finish]** is only shown if no forwarding should be performed.
 - The wizard is closed and the new rule is added to the list of alarm messages.
 - the **With lack of confirmation, forward to** if the alarm message is to be forwarded to another recipient.
 - The **min** input field for entering the time interval after which the alarm message should be forwarded is shown along with the selection list for determining the next recipient.
7. In the **min** field, enter the interval after which the alarm message should be forwarded. (Time between the alarm being received by recipient 1 and it being forwarded to recipient 2).
8. Determine the receiver who is to receive the alarm message in the **to** selection list.

i The output targets (SMS or e-mail) for receiver 1 and receiver 2 must not vary. For all receivers in an alarm chain, the same output target (all SMS or all e-mail) must be set, otherwise the alarm chain is interrupted.

9. Click on **[Continue >]**.
 - The dialogue for the forwarding function or for finishing the alarm rule is shown.

10. Either

- click on **[Finish]** if the alarm message should not be forwarded if the alarm is not acknowledged or
- The wizard is closed and the new rule is added to the list of alarm messages.
- the **With lack of confirmation, forward to** if the alarm message is to be forwarded to another recipient.
- The min input field for entering the time interval after which the alarm message should be forwarded is shown along with the selection list for determining the next recipient.

11. In the **min** field, enter the interval after which the alarm message should be forwarded. (Time between the alarm being sent to recipient 2 and it being forwarded to recipient 3).

12. Determine the receiver who is to receive the alarm message in the **to** selection list.



The output targets (SMS or e-mail) for receiver 1 and receiver 2 must not vary. For all receivers in an alarm chain, the same output target (all SMS or all e-mail) must be set, otherwise the alarm chain is interrupted.

13. Click on **[Finish]**.

- The wizard is closed and the new rule is added to the list of alarm messages.

14. Exit "Alarm Management" menu.

- Alarm settings are transferred to the devices.

6.5.5. Alarm overview

In the alarm overview you will find a list of the groups with their specific alarm settings.

1. Click on **Alarm management** in the navigation area.

- The data area shows the sub-menus **Base alarm settings**, **Component alarm settings**, **Channel alarm settings**, **Alarm recipients**, **Alarm rules**, **Comments for acknowledging alarms**.
2. Click on **Alarm rules**.
- The defined alarms are displayed in the display area.

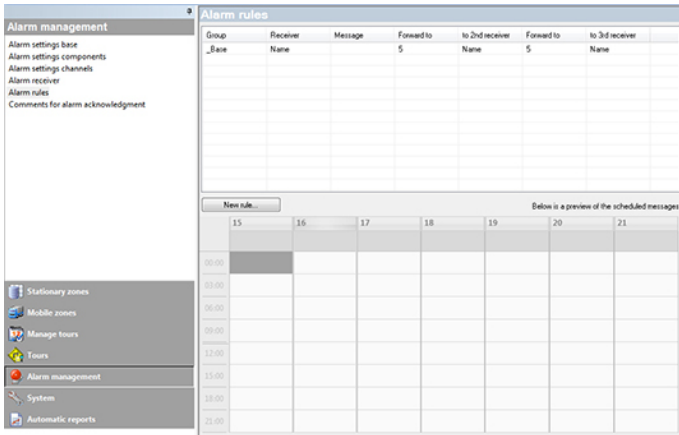

6.5.6. Comments for acknowledging alarms

You can create standardised acknowledgement comments, which are displayed in the acknowledgement window as a selection list.

1. Click on **Alarm Management** in the navigation area.
 - The data area shows the sub-menus **Base alarm settings**, **Component alarm settings**, **Channel alarm settings**, **Alarm recipients**, **Alarm rules**, **Comments for acknowledging alarms**.
2. Click on **Acknowledgement comments**.
 - The defined acknowledgement comments are displayed in the display area.

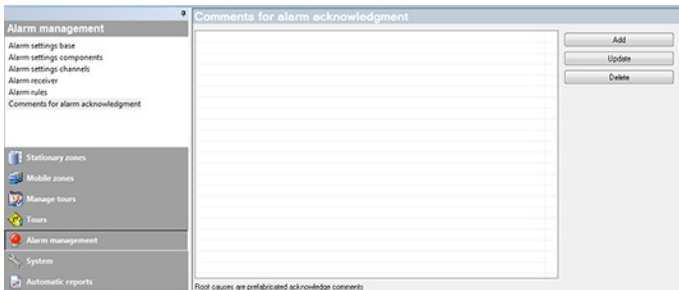

3. **[New]**: Create an acknowledgement comment.
- [Edit]**: Edit an existing acknowledgement comment.
- [Delete]**: Delete an existing acknowledgement comment.

6.6. Analyzing series of measurements

You can represent series of measurements as a diagram or a table.

- > In the **Start | View** menu, select the
 - Mark **Graph** if the data should be displayed graphically and select the display format.
The measurement data can be displayed as **Diagram**, **Histogram** or **Number field**.
 - **Table** function if the data should be displayed as a table.

6.6.1. Diagram view

In this view, the readings are shown as line diagrams.

In the **Start | View** menu, the **Diagram** command is activated. Now you have to select the data record that you wish to display.

1. Select the day or time period in the calendar that should be evaluated.
 2. In the tree structure of the data range, open the group that contains the data to be displayed.
 - The diagram for the selected data is shown.
- > If necessary, deactivate channels via the checkboxes for the display.

i You can show or hide the gridlines for the corresponding axis by clicking on the time axis or the value axis.

6.6.1.1. Enlarging the view

Zoom in on a detail of the diagram to check the behavior of the readings within a specific time span, for example.

1. Click on **Edit | Tools | Zoom in**.
2. In the diagram, use the left mouse button, pressed and held, to highlight the area that should be shown enlarged.

i Click on **[Original size]** and the entire diagram is shown again.

6.6.1.2. Information on a reading (crosshairs)

If you move your crosshairs along a curve, you will quickly receive detailed information on the individual readings.

1. Click on **Edit | Tools | Crosshairs**.
2. In the diagram, click on the point for which the details should be shown.
 - A dialogue with the following information on the reading is shown:
 - date on which the reading was recorded,
 - time at which the reading was recorded,
 - number of the reading and
 - reading.

i You can move along the curve with the left mouse button pressed and held and thereby see the individual information for the readings.
In doing this, it is not necessary to exactly follow the course of the curve; the crosshairs does this automatically if you move the mouse to the right or left.

6.6.1.3. Showing regression curve

Place the regression curve over the diagram to show the course that the measurement series tends to take.

1. Click on **Edit | Tools | Regression curve**.
2. Click on the reading curve for which the regression curve should be shown.
 - The regression curve is shown and displayed in the status bar of its regression coefficients.

i If you click on the curve again, the regression curve is hidden again.

6.6.1.4. Text field

Insert a text field to enter comments and additional information in the curve.

Insert text field

i The text field may potentially cover parts of the curve. In this event, the text field must be positioned in such a way to ensure that the curve is not concealed.

1. Click on **Edit | Tools | Insert text**.
 - A text field is displayed in the diagram.
2. Fill the text field with the required content.
3. Click on the border of the text field and move it so that the curve is not concealed.

Delete text field

1. Click on the text field and remove all the contents.
 - The text field is deleted.

6.6.1.5. Characteristics of a curve

You can adapt the representation of a measurement series to your requirements. For example, you can change the line weight of a curve or the representation of the limit values in the diagram.

1. Change to the diagram view of the measurement series, the characteristics of which are to be displayed.
2. Click in the **Edit | Curves** menu on the entry of the curve, the characteristics of which are to be displayed.
 - The **Characteristics of (name of curve)** dialogue is opened.

The following tabs are available in the dialogue:

- **Curve** tab
- **Range limits** tab
- **Statistical computation** tab.
- **Data sequence** tab

Buttons of the dialogue

Button	Explanation
[OK]	Applies the changed settings. The dialogue is closed.
[Cancel]	Closes the dialogue without applying the changes.

Curve tab



Designation	Explanation
Smooth	The measurement points are connected by an interpolated curve; the plot-points on the curve between two measurement points are estimated mathematically.
Mark measuring points	The individual measurement points are represented by a symbol. i The value shown only corresponds to the exact measured value at these points. The measurement points are connected with straight lines during the measurement. When the measurement is paused the curve can be smoothed.
Colour	Line colour of curve.
Width	Line weight of curve.
Style	Line pattern of curve.

Designation	Explanation
Marker	Symbol for the measurement points.
Degree of regression	Possible values "0" to "7". The "0" degree represents a pure mean calculation, the "1" degree of regression the linear trend, a higher value helps in the event of curves with several extreme values.

Range limits tab

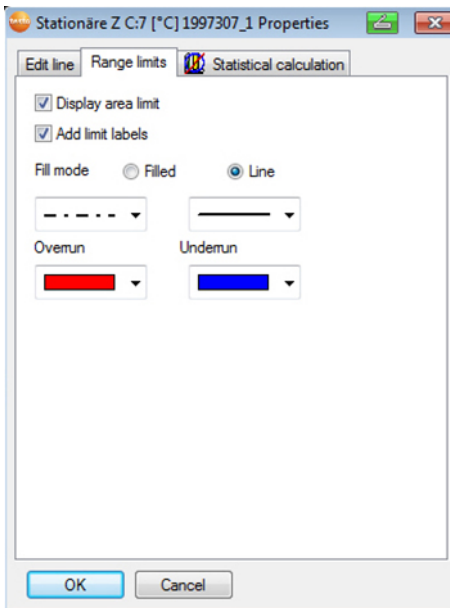

Designation	Explanation
Display area limit	Specification as to whether the limit values should be shown in the diagram.
Add limit labels	Specification as to whether the limit values should be labelled (Upper/Lower limit value: name of curve).
Area fill	Specification as to whether the areas outside of the limit values should be marked by means of an area fill.
Selection list for area fill	Selection of the fill.

Designation	Explanation
Line fill	Specification as to whether the limit values should be by means of horizontal lines.
Selection lists for line fill	Selection lists for line type and line thickness.
Overshoot	Colour selection for the fill of the area above the upper limit value.
Undershoot	Colour selection for the fill of the area below the lower limit value.

Statistical computation tab

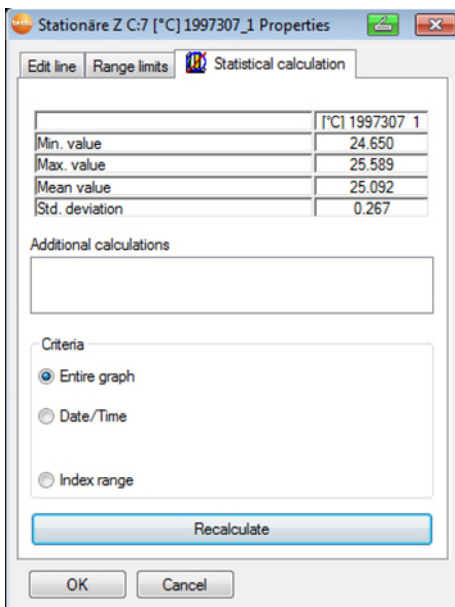

Designation	Explanation
Min. value	Smallest reading of the curve.
Max. value	Largest reading of the curve.
Mean value	Arithmetically-determined average value.
Std. deviation	Measure of the scattering of the readings around the average.

Designation	Explanation
Criteria	Display criteria setting: all, date/time and index range.
Recalculate	Recalculates the curve.

6.6.1.6. Settings for the axes in the diagram

Change the settings of the axes in the diagram to adapt the representation to your requirements.

Settings for the value axis

- >Click on the required value axis in the diagram by double-clicking or using the right mouse button.
- The **Change axis [unit of the readings]** dialogue is shown.

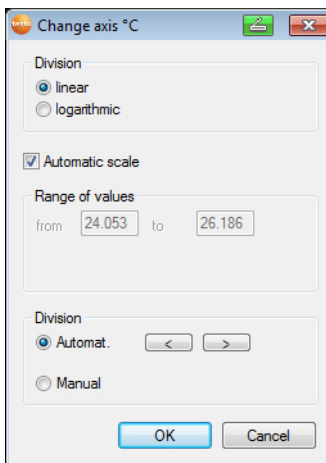

Designation	Explanation
Division linear	Specification that the axes are divided in a linear manner.
Division logarithmic	Specification that the axes are divided logarithmically, meaning the increments represent powers of ten.
[OK]	Applies the settings until other data are called up. The dialogue is closed.
[Cancel]	Closes the dialogue without applying any changes.

Designation	Explanation
Automatic scale	Specification as to whether the program should perform the scaling of the value axis.
Range of values from ... to	Manual entry of the range of values if the Automatic scale is deactivated.
Division Automat.	Specification that the program should perform the division of the axis.
Division Manual	Specification that the division of the axis should be performed manually.
Grid [<], [>] (if automatic division is activated)	Decrease or increase the division of the axis by clicking on [<] or [>].
Interval (if manual division is activated)	Manual entry of the grid.

Settings for the time axis

- > With the right mouse button, click on the time axis in the diagram.
- The **Adjust time axis** dialogue is shown.

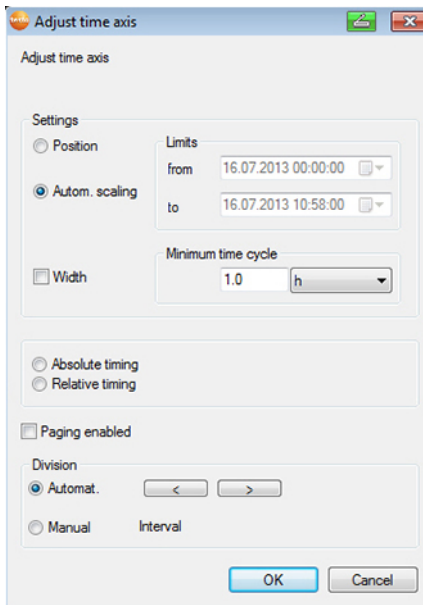

Designation	Explanation
[OK]	Applies the settings until other data are called up. The dialogue is closed.
[Cancel]	Closes the dialogue without applying any changes.
Position	Shows a freely-definable extract of the diagram.
Autom. scaling...	Shows the entire diagram in the window.
Extract	Shows a fixed, defined extract that can be moved over the time axis.
Limits from ... to (if Position view is activated)	Limits for the Position view.
Minimum time cycle (if Extract view is activated)	Specification of which time period should at least be shown.
Selection list for the unit (if Extract view is activated)	Unit of the time axis in the minimum time cycle: <ul style="list-style-type: none"> • sec (second) • min (minute) • h (hour) • d (day).
Absolute	All times are the real times at which the readings were recorded.
Relative	Sets the starting time to 00:00; the time the runs relative to this starting point.
Paging enabled	The function associated with this is not available in the Small Business Edition.
Division Automat.	Specification that the program should perform the division of the axis.
Division Manual	Specification that the division of the axis should be performed manually.
Grid [<], [>] (if automatic division is activated)	Decrease or increase the division of the axis by clicking on [<] or [>] .
Interval (if manual division is activated)	Manual entry of the grid.

Designation	Explanation
Selection list for the unit (if manual division is activated)	Unit of the time axis: <ul style="list-style-type: none">• sec (second)• min (minute)• h (hour)• d (day).

6.6.2. Histogram view

In this view, the readings are shown as a histogram, meaning the last reading of a channel is shown as a column.

In the **Start | View** menu, the **Histogram** command is activated. Now you have to select the data record that you wish to display.

1. Select the day or time period in the calendar that should be evaluated.
 2. In the tree structure of the data range, open the group that contains the data to be displayed.
 - The histogram for the selected data is shown.
- > If necessary, deactivate channels via the checkboxes for the display.

6.6.3. Monitor view

In this view, the readings are shown as number fields. If you take advantage of the opportunity to insert a background picture, e.g. the floor plan of a building, you quickly achieve a spatial overview of the current climatic conditions.

In the **Start | View** menu, the **Monitor** command is activated. Now you have to select the data record that you wish to display.

1. Select the day or time period in the calendar that should be evaluated.
 2. In the tree structure of the data range, open the zone that contains the data to be displayed.
 - The monitor display for the selected data is shown.
- > If necessary, deactivate channels via the checkboxes for the display.

6.6.4. Table view

The readings are listed in table form in this view.

In the **Start | View** menu, the **Table** command is activated. Now you have to select the data record that you wish to display.

1. Select the day or time period in the calendar that should be evaluated.
2. In the tree structure of the data range, open the zone that contains the data to be displayed.
 - The table view of the selected data is shown.
 - > If necessary, deactivate channels via the checkboxes for the display.

6.6.4.1. Marking readings

Mark specific readings to perform a statistical computation for part of the measurement series, for example.



The min, max and average values cannot be calculated via a period/index range defined in the table.

1. Click on **Edit | Tools | Mark**.
 - A dialogue for determining the criteria is shown.

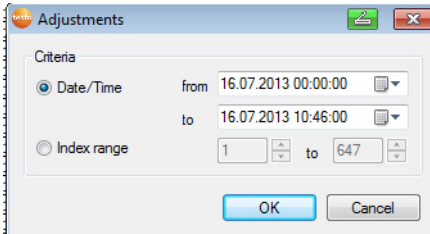

2. Select the
 - Select **Date/time** if the readings for a particular time period are to be marked.
 - The selection lists are enabled for the determination of the time period.
 - Select the **Index range** if the readings in particular rows in the table are to be marked.
 - The selection lists are enabled for the determination of the index range.
3. Determine time period or index range.
4. Click on **[OK]**.
 - The dialogue is closed and the corresponding readings are marked in the table.

i The selected readings can be copied and further edited using suitable software (e.g. with Microsoft® Excel®).

6.6.4.2. Dropping the marking

- > Click on **Edit | Tools | Drop marking**.
- The marking of the readings is deleted.

6.6.4.3. Inserting extreme values or mean in the table

Insert the minimum/maximum reading as well as the mean from the whole table at the end of the table.

1. Click on **Edit | Tools | Extra lines | Minimum, Maximum or Mean value**.
- A row with the corresponding value for all readings is inserted at the end of the table.
- > Repeat step 1 to insert another value in the table.

i To erase a value from the table again, click in the **Extra lines** menu again on the corresponding entry.

6.6.4.4. Compressing readings

Compress the table to definable intervals to maintain the clarity of the table with large amounts of data.

Only the first and the last value are shown for the individual intervals. The other readings are hidden.

In addition, the minimum, maximum and/or average value can be shown for the respective time period.

1. Click on **Edit | Tools | Compress**.
- The dialogue for determining the options is opened.

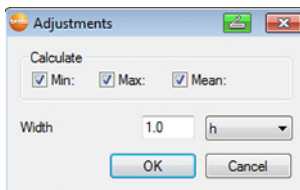

- > Use the checkboxes to determine whether the respective minimum reading (**Min**), maximum reading (**Max**) and/or average value (**Mean**) should be calculated for the individual time spans.

i At least one of these values must be activated to be able to perform the compression of the table.

2. Enter the time span under **Extract** and determine its unit.
Possible settings for the unit:
 - **sec** (second)
 - **min** (minute)
 - **h** (hour)
 - **d** (day).
3. Click on **[OK]**.
 - The dialogue is closed and the table is shown compressed.

6.6.4.5. Dropping compression

- > Click on **Edit | Tools | Drop compression**.
- The table is shown again in its uncompressed form.

6.6.4.6. Determining largest reading

- > In the **Edit | Find | Maximum** menu click on the curve for which the largest reading should be determined.
- The largest reading is shown marked in the table.

6.6.4.7. Determining the smallest reading

- > In the **Edit | Find | Minimum** menu click on the curve for which the smallest reading should be determined.
- The smallest reading is shown marked in the table.

6.6.4.8. Add rows

- > In the **Edit | Tools | Add rows** menu, activate the selection that is to be displayed in extra rows.
- The extra rows are displayed in the table.

6.6.4.9. Compress

Tabular values are displayed in compressed format. The limits for the compression range and the additional Min, Max and Mean values are displayed.

- > Click in the **Edit | Tools | Compress** menu, a selection window appears.
- > Set the calculation and extract and confirm with **OK**.
- The table display is reduced to the selected Min, Max and Mean values, and the entered time period.

6.6.4.10. Drop compression

The table compression is removed.

- > Click in the **Edit | Tools | Drop compression** menu.
- The table is displayed with all the individual values once again.

6.7. Analyzing alarms

If system or probe alarms were triggered by the Saveris base, you can check the alarms and subsequently confirm (acknowledge) them.

6.7.1. Checking alarms

- > In the diagram or table view under **Start | View** mark the **Alarms** option.
- The alarms received are shown in the **Overview** below the diagram or the table.

Source	Time	Condition	Status	Comment
1730073_1	04.07.2012 12:39:01	Low battery	Alarm input;	-----
2002348_3	04.07.2012 12:24:15	14.9 Hyst 0.0 td °C<15.0 H...	Alarm input; Confirmed;	-----
2002348_3	04.07.2012 12:24:00	14.9 Hyst 0.0 td °C<15.0 H...	Alarm input;	-----
1730073_1	04.07.2012 11:39:07	Low battery	Alarm input; Confirmed;	-----
1730073_1	04.07.2012 11:09:01	Low battery	Alarm input;	-----
1730073_1	04.07.2012 10:53:52	Low battery	Alarm input; Confirmed;	-----
1730073_1	04.07.2012 10:51:57	Low battery	Alarm input;	-----

Designation	Explanation
Source	Probes on which the breach of the limit value has occurred.
Time	Date and time at which the message is received.
Condition	Condition that was fulfilled so that the alarm was triggered; e.g. Limit value overrun .
Status	Date and time, when the alarm was triggered.
Comments	Any comments on the alarm.
Tel. number/name	Telephone number or recipient for the alarm message

- > If needed, enter **Comments** on an alarm in the column of the same name.

6.7.2. Acknowledging an alarm

















If you acknowledge an alarm at the Saveris base, this is carried over into the software.

If you have received an alarm message by SMS, you can acknowledge the alarm by sending the received SMS with the same text back to the mobile number of

the Saveris base.
(Not available with software version CFR).

- > Under **Start | Mode**, click on **Online**.
Switch to the **Acknowledgement** tab.
- The list of the registered channels is shown in the calendar and acknowledgement area.

Source	Time	Condition
 1994891		
 1994891_1		
 mob_792		
 1992792_1		
 1997307		
 1997307_1		
 1997307_2		
 Türkontakt_8		
 2002348		
 2002348_1		

Designation	Explanation
Source	Designation of the individual channels of the registered probes.  The channel delivers measurement data within the limit values.  The Saveris base has triggered a system alarm.  The Saveris base has triggered a warning.  A limit value has been breached and the Saveris base has triggered an alarm.
Time	Date and time when the alarm was triggered.

4. Click on the  symbol in front of the alarm entry you want to confirm.

Or

1. Click on the alarm status display.
- The **Acknowledgement** dialogue box is opened.

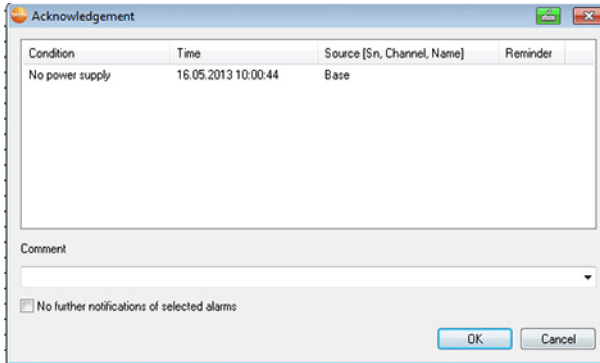

2. Select the entry for the alarm to be acknowledged.
 3. If necessary, enter a **Comment** in the relevant field for the alarm or select one from the acknowledgement comments drop-down list and confirm the alarm with **[OK]**.
- > Where a repeat alarm is set up via the alarm configuration after acknowledgement of an alarm, you can tick the **Do not remind me again** checkbox to specifically suppress a repeat alarm for selected alarms.
 - The  symbol shows that the alarm has been confirmed and the comment is transferred to the alarm list in the display area. Confirmation of the alarm is transmitted to the Saveris base. As soon as confirmation is received by the Saveris base, the alarm relay and alarm status stop flashing and the alarm is deleted.

6.8. Creating evaluations

You can print out series of measurements or have reports on the data created automatically by the software in definable intervals or manually at the desired period.

6.8.1. Printing measurement data

Measurement data can be printed in diagram or table form.

1. Select the day or time period in the calendar for which the report should be created.
 - The data for the day or the time period are shown as a diagram or table, depending on the setting.
 - > In the **Start | View** menu, select the
 - **Diagram** command if the table view is activated but the diagram view should be printed.
 - **Table** command if the diagram view is activated but the table view should be printed.
2. Select the type of report head in the **Template | Template** menu.



Open the preview of the report using the **File** (Testo logo) | **Print preview** command.

Use portrait format for printing a table and landscape format for printing a diagram.

You can determine the format under **File | Page Setup...**

3. Select the **Print** command in the **File** menu.
 - The **Print** dialogue for selecting the printing options is shown.
4. Change printing options, if needed, and click on **[OK]**.
 - The report is printed.

6.8.2. Archiving with automatic reports

A simple and secure option for archiving your data is the automatic creation of reports.

The reports are created by the software and recorded on a daily, weekly or monthly basis at a specified location on the computer or a server; also see the chapter "**Report settings**" for this.

The reports are saved as PDF files so that they can easily be read or sent per e-mail but without being able to change the data stock.

6.9. Checking the database capacity

- i** • The free database system Microsoft® SQL Server® 2008 R2 Express is installed as standard with the testo Saveris software.
- The Microsoft® SQL Server® 2008 R2 Express can manage databases up to a size of 10 GB.

i The possible duration of the recording is primarily determined by the measuring rate with a constant number of channels.
If the Saveris base, for example, records the data from 20 channels with a measuring cycle of 2 minutes, the database can save data for longer than ten years in this configuration.

1. Under **Start | All Programs | Testo**, click on **Testo Saveris Startup Wizard**.
- The welcome dialogue box for the startup wizard is displayed.

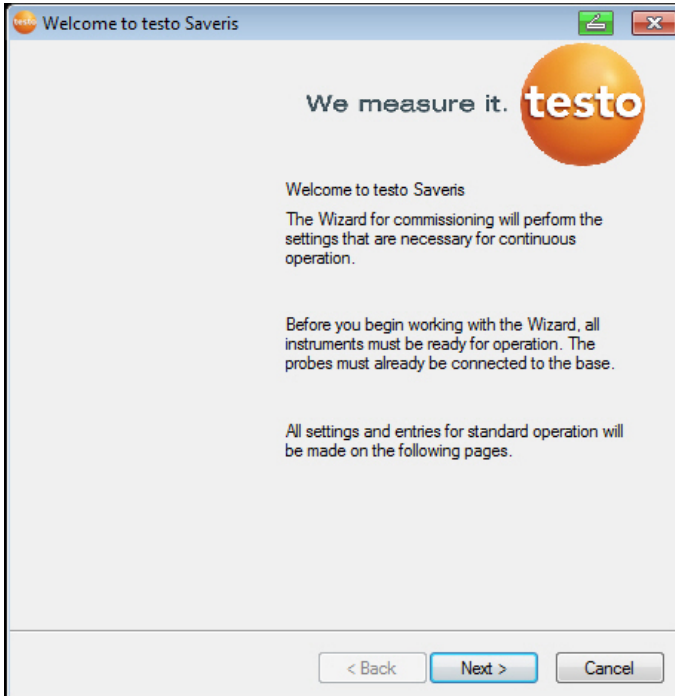

2. Click on **[Next >]**.
 - The **System status** dialogue box is displayed with the tab **General**.
3. Switch to the **Projects** tab.
4. Select the project you want to end and click on **[End measurement]**.
 - A notification is displayed for you to confirm the reset of the Saveris base to the basic configuration.
5. Select whether the system components should be logged out from the Saveris base or remain logged on.
 - The project is completed in the Saveris software.



Once the measurement has ended, the radio probe should continue to run for a further two communication cycles for data synchronisation before another measurement can be started again.

To start a new project, you must register all components on the Saveris base again and then restart the hardware.

6.10. System settings

In this menu, determine the settings for the Saveris base, the radio probes and – if installed in the measuring system – the Ethernet probes, router, converter, analogue coupler, extender and cockpit units.

- > Click in the navigation area on **System**.
 - The following menus are displayed:

Menu **System** | **Management**

Menu function	Description
Projects	Opens the dialogue box for selecting a project.
Measurement records	Opens a log file that you can send to Customer Service in the event of a problem.
System test	Use this function to test individual functions of the Saveris system. Please contact Testo Customer Service. Contact details can be found at www.testo.com/service-contact

Menu function	Description
Database backup	<p>Creates a backup file for all projects.</p> <p>i Administrator rights are required and the directory to which the backup file is to be saved must be activated for the network service.</p>
Restore database	<p>Loads the previously saved backup file and thereby enables access to the saved project data.</p> <p>i Administrator rights and re-installation of the system are required. The startup wizard must not be started before restoring the database.</p> <ol style="list-style-type: none"> 1. Open Saveris Client. 2. Select Project on the dialogue box and click on [Cancel]. 3. Click on Options <input type="checkbox"/> Management Restore database. 4. Select the *.bak file containing the database backup. 5. In the Find folder dialogue box, select the directory for the backup (e.g. c:\Programs\Microsoft SQL Server\MSSQL.1\MSSQL\Data\). 6. Confirm the following messages with [OK]. The overview window of the projects is simply a source of information. <ul style="list-style-type: none"> - The database is restored. 7. Close Saveris Client.
Backup settings	<p>Opens the dialogue box for setting the automatic protection.</p> <p>i For security reasons, backup files should be saved on a different PC to the Saveris database.</p>

Menu System | Security

Menu function	Description
Authorisations	Limits zone access to certain user accounts, see Assigning zones, page 118.
Audit trail	Display, save or export audit trail file.

Menu function	Description
Hash code	Generates a hash code
Raw data export	Creates a vi2 file per probe with all measurement data from the Saveris base (not from the database).

Menu System | Search

Menu function	Description
Search	Opens a search window, where you can search through zones and channels using a text word search.

- In the data area, the following entries are displayed in the tree structure:
 - **Base** with the general settings of the Saveris base and the SMS module (if present), as well as the operating data of the probes.
 - **Radio probe** with the settings for the radio probes or radio analog couplers registered on the Saveris base. Radio probes assigned to a mobile zone are indicated with a tyre symbol.
 - **Ethernet probe** with the settings for the Ethernet probes or Ethernet analog couplers registered on the Saveris base.
 - **Router** with the settings for the routers registered on the Saveris base.
 - **Converter** with the settings for the converters registered on the Saveris base.
 - **Extender** with the settings for the extenders registered on the Saveris base.
 - **Cockpit unit** with the settings for the cockpit units registered on the Saveris base.

6.10.1. General settings for the Saveris base

Via this menu item, you can for example synchronize the date and time of the Saveris base with the values of the computer.

1. Open the **Base** entry.
 - The submenu items **General** and **Operating data** are shown below the entry.
2. Click on **General** to open the basic settings for the Saveris base.
 - The settings of the Saveris base are shown in the display range.

General

Serial number: 2050717

Firmware: 2.50

Date and time
04.07.2012 12:42:58

Update system state view

Designation	Explanation
Serial number	Serial number of the Saveris base.
Firmware	Version number of the instrument software in the Saveris base.
Date and time	Date and time of the Saveris base.

6.10.2. Show operating data of the probes.

Using this menu item, you can check when the last data were received from a probe, for example, and the duration until the next readings can be expected.

1. Open the **Base** entry.
 - The submenu items **General** and **Operating data** are shown under the entry.
2. Click on **Operating data** to look at the connection data.
 - The connection data are listed in the display range according to probe.

Operating data		Date/Time	Action	Parameter
Serial no.	Most recent data transfer			
1730073	04.07.2012 12:41:32. 1			
1992792	04.07.2012 12:28:40. 15			
1994891	28.06.2012 20:28:12. 15			
1997307	04.07.2012 12:28:31. 15			
2002348	04.07.2012 12:24:02. 1			

6.10.3. Settings for the radio probe

Using this menu item you can, for example, check the battery status of the probe or the quality of the radio transmission.

1. Open the **Radio probe** entry.
 - The radio probes connected in the Saveris base are listed under the entry.
2. Click on one of the probe names to open the information on the probe.
 - The settings of the selected radio probe are shown in the display range.

Wireless probe

Serial number: 1992792

Firmware: 2.64

Radio quality

Totally Today

Communication statistics

Measuring rate

Battery status

Battery type

Type NTC internal

Adjustment data

Display

Unit	Line
°C	1

Designation	Explanation
Serial number	Serial number of the probe.
SN humidity module	<p>Serial number of the connected external humidity probe.</p> <p>i The serial number of the humidity probe that was connected at the time of the connection of the humidity probe to the base is shown.</p> <p>When changing the external humidity probe: Briefly press the connect key on the corresponding humidity probe.</p>

Designation	Explanation
Firmware	Version number of the probe's instrument software.
Radio quality	Field strength of the last radio link to the Saveris base.
Communication statistics	successfully transferred data in total or current
Meas. cycle	Interval in which the measurements should be performed.
Battery status	Remaining capacity of the batteries in the probe..
Battery type	Selection list for specifying the battery type (AlMn or Energizer)
Type	Specification of the probe type.
Import adjustment data	Button for importing the adjustment data of the probe.
Display adjustment data	Button for displaying the adjustment data of the probe that has already been imported.



Display of radio statistics: in the case of registered stationary probes, this relates to continuous recording, while in mobile probes, statistics describe the transfer quality during data transfer to the ramp, i.e. only for the period in which the probe is in range of the Saveris base/extender.

6.10.4. Ethernet probes

Using this menu item, you can check the version of the instrument software of an Ethernet probe, for example.

1. Open the **Ethernet probe** entry.
 2. Click on one of the probe names to open the information on the probe.
- The settings of the selected probe are shown in the display range.

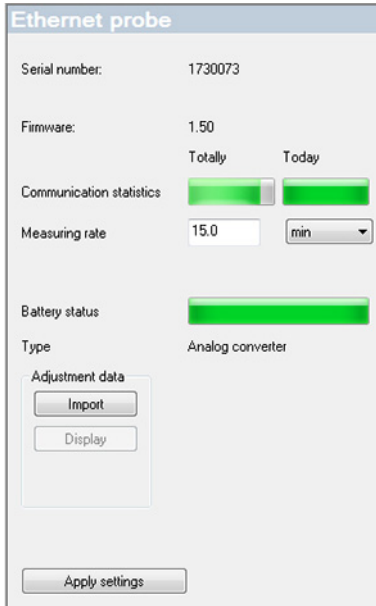

Designation	Explanation
Serial number	Serial number of the probe.
SN humidity module	<p>Serial number of the connected external humidity probe.</p> <p>i The serial number of the humidity probe that was connected at the time of the connection of the Ethernet probe to the base is shown.</p> <p>When changing the external humidity probe: Briefly press the connect key on the corresponding Ethernet probe.</p>
Firmware	Version number of the probe's instrument software.
Communication statistics	successfully transferred data in total or current
Meas. cycle	Interval in which the measurements should be performed.
Type	Specification of the probe type.

Designation	Explanation
Import adjustment data	Button for importing the adjustment data of the probe from the adjustment software.
Display adjustment data	Button for displaying the adjustment data of the probe that has already been imported.

6.10.5. Analog coupler

Via this menu item you can change the power supply of the analog coupler or reset a sum channel, for example.

With the radio analog coupler U1 the same information is shown under the **Radio probe setting** entry as with the radio probe (see **Settings for the radio probe** page 161).

With the Ethernet analog coupler U1E the same information is shown under the **Ethernet probe setting** entry as with the Ethernet probe (see **Ethernet probes** page 163).

1. Open the **Radio probe| Ethernet probe > Scaling** entry.
 - The settings of the selected probe are shown in the display range.

The screenshot displays the 'Scaling' configuration interface. On the left, a 'System' tree lists various components, with 'Scaling' highlighted under the 'Ethernet probe' section. The main area shows the following settings:

- Socket:** Voltage: 0.10 V
- Display:** from 0.000 to 10.000, Unit: mA
- Voltage output:** On, Off
- Totalizer reset:** A button to reset the totalizer.

Designation	Explanation
Connection	Output signal of the transmitter.

Designation	Explanation
Display	Display range of the physical unit.
Unit	Specified or user-specific unit.
Voltage output	Selection option of whether the power is to be supplied to the transmitter via the analog coupler (on) or separately (off).
[Reset sum channel]	Button for resetting the sum channel. The sum channel is reset to 0.00.

6.10.6. Saveris cockpit unit

Via this menu option, you can configure the measured value printout using the Testo standard printer.



The measured value printout covers up to the past 12 hours.

The measured value printout includes:

- Print time with date and time
 - Tour start/tour stop (date and time)
 - Start print area (date and time)
 - Name of the tour description and the selected mobile zones
 - Probe designation with serial number
 - Min., max. and average values for each probe within the tour
 - Printout of the measured values in 15 min. intervals (only available on the "Large" measured value printout)
1. Open **Cockpit unit**.
 - In the display area, the settings for the selected Saveris cockpit unit are displayed.

Cockpit unit

Serial number: 2053028

Firmware: 2.50

Printer text

Row 1

Row 2

Row 3

Row 4

Row 5

Mark alarms

Print a signature line

Designation	Explanation
Print text	Five freely definable text lines on the measured value printout
Identify alarms	Identification of the alarms on the measured value printout with (*)
Print signature line	Additional signature line, e.g. for the goods recipient

6.11. Report settings

In the report settings, you can determine how the automatic reporting should take place.

- > In the navigation area, click on **Automatic reports**.
- In the data window, the **Settings for automatic reports** sub-menu is displayed.

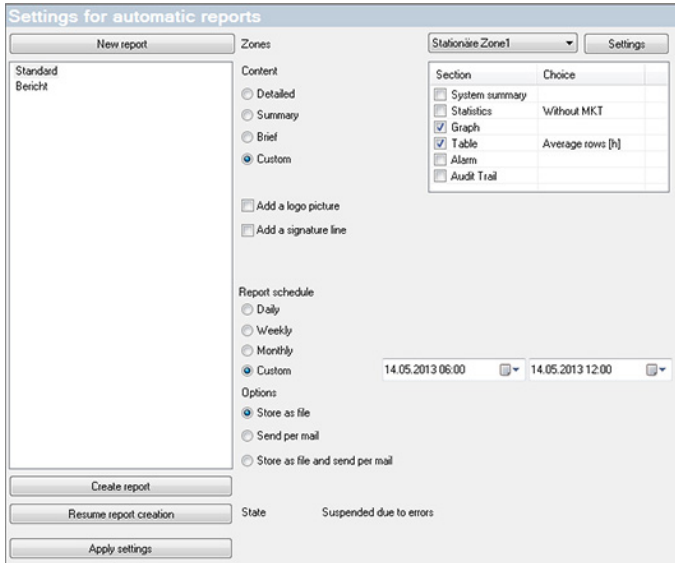

Designation	Explanation
[New report]	Adds a new reporting task to the list.
List of the reporting tasks	List of the created reporting tasks.
Zones	Selection list of the group for which the report should be generated.
Group box Content	When option is enabled, the corresponding data sheet is attached to the report <ul style="list-style-type: none"> • Detailed • Compact • Brief • Custom • Insert logo • Insert signature line

Designation	Explanation
Timing of the report generation	<p>Specify whether the report is to be generated daily, weekly, monthly or at a custom time.</p> <p>i Daily: The report is created daily at 1 a.m.</p> <p>Weekly: The report is created every Sunday at 1 a.m.</p> <p>Monthly: The report is created on the last day of the month at 1 a.m.</p> <p>Custom: A future time period can be set (start date/time, end date/time), upon which a report is to be created one time only. The report is created after the time period has elapsed.</p>
Options	<p>Specify how the report is to be used: Store as file, Send per email, Store as file and send per mail.</p> <p>i Store as file: The report is saved on the PC.</p> <p>Send per mail: The report is sent to an email address entered.</p> <p>Store as file and send per mail: The report is saved on the PC and sent to an email address entered.</p>
Recipient input field	Input field for the e-mail address of the employee to whom the report is to be sent.
Create report	Creates a report, thus testing the configured report functions.
Apply settings	Saves the report configurations.
<p>i The storage location for the reports was determined during the installation of the Saveris software. The path specification is shown below the Determine folder field.</p>	

7 Maintaining the product

7.1. Maintenance

i If possible, create a database backup of the current system before carrying out any system maintenance, see Testing the system, page 99.

The stored Saveris base data can only be imported to a Saveris base with the same firmware status. The memory capacity of the target base must be larger than or equal to the source base. For the memory size, see the **Select language** window.

Maintenance includes:

- Registering/deregistering components (calibration outside the current system)
 - System reboot
 - Firmware and software update
 - Changes in alarm management.
-

i The larger a Saveris system, the more important it is to carry out a random system test after any maintenance/major intervention or configuration, see Testing the system, page 99.

7.2. Replacement of components

You can shut down a component – probe, converter or router – at any time because this is temporarily not in use or to replace it with a new component, for example, in the event of a defect.

i In the event of a replacement of the Saveris base, a new project must be created. Please contact our software hotline if required (softwarehotline@testo.de).

7.2.1. Deleting components

1. Under **Start | All Programs | Testo** click on **Testo Saveris Startup Wizard**.
 - The welcome dialogue of the startup wizard is shown.

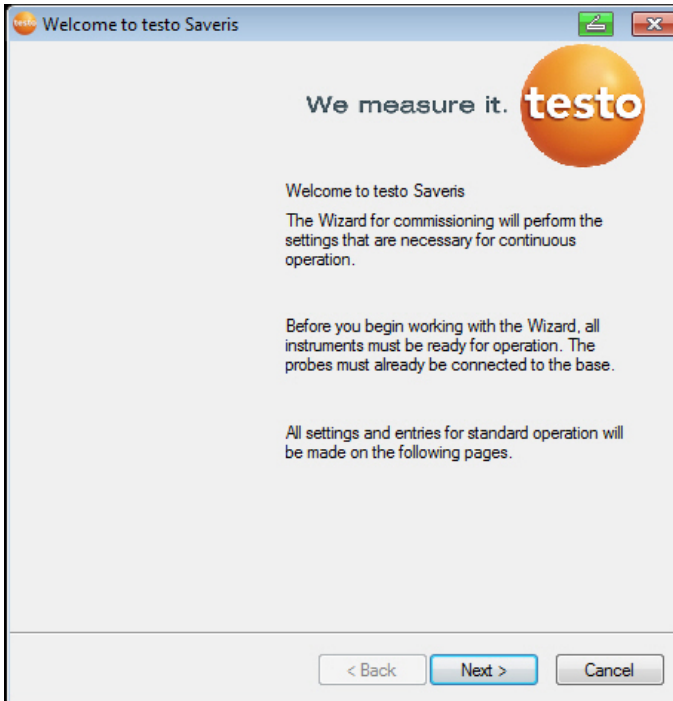

2. Click on **[Continue >]**.
 - The **System status** dialogue with the **General** tab is shown.

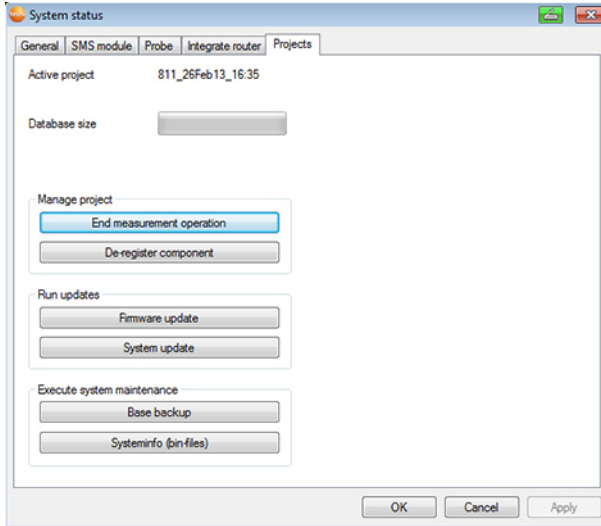

3. Change to **Projects** tab.
4. Click on **[De-register component]**.
 - The **De-register component** dialogue is shown.

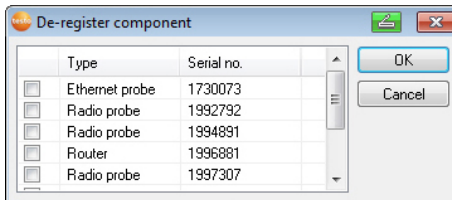

5. Activate the checkbox in front of the component that is to be de-registered from the system.

i Before deleting a router, you should assign the relevant assigned probes directly to the base to ensure data availability.

6. Click on **[OK]**.
 - A query to erase the component from the configuration is shown.

7. Confirm the query with **[Yes]**.
 - The component is deleted from the configuration.
 - > After deleting a probe, briefly press the Connect button on the rear of the probe so that the probe no longer attempts to send measurement data.

7.2.2. Adding new components



With the subsequent addition of a component, it is possible that the measuring cycle is not synchronous with that of the components already present.

This results in the readings seeming to be missing in the table view if readings are not input from all probes at a point in time.

1. Register new probe on the Saveris base; see Connecting radio probe, page 49.
2. Start the testo Saveris startup wizard.
 - The startup wizard is opened.

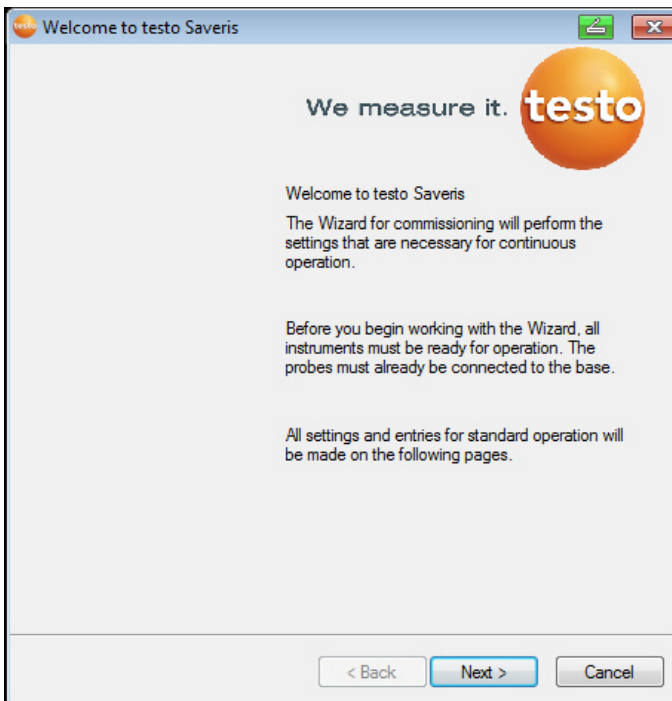

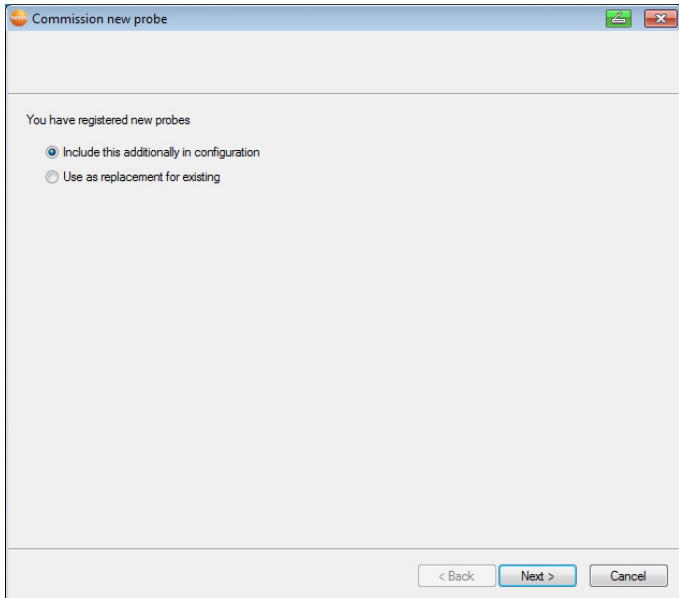

3. Click on **[Next >]**.

- The **Commission new probe** dialogue box is displayed.

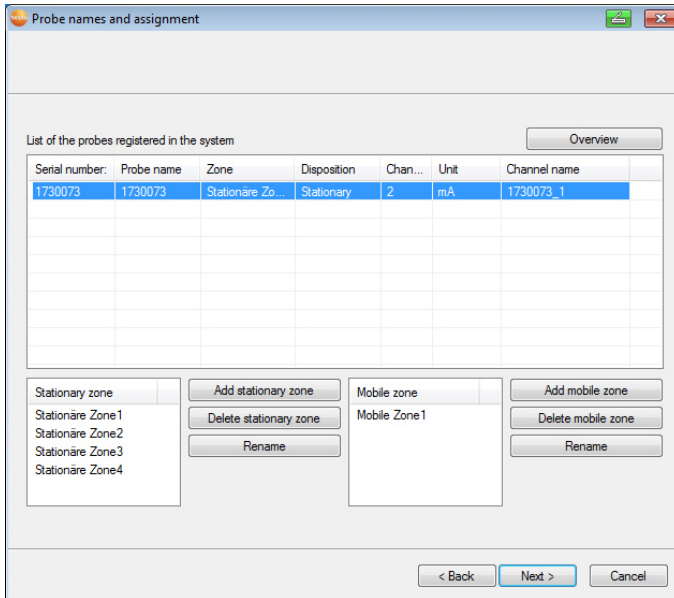

4. Leave default setting and click on **[Next >]**.
- The list of probes newly registered in the Saveris base is displayed.



5. To distribute the probes already registered on the system between stationary or mobile zones depending on the purpose (for Saveris mobile): Click on **[Add stationary zone]** or **[Add mobile zone]**.
6. Open the selection list via button  and select the zone to which the probe should be assigned.

i All channels of a probe must be assigned to the same zone.

7. Click on **[Next >]**.
8. Click in the **TE type** field and enter the thermocouple element type (**K**, **J**, **T** or **S**) if this information is necessary for the device.
9. If required, change the default values in fields **Probe name** and **Channel name**.

i Assign channel names that are not longer than 20 characters.

10. If required, import adjustment data for the individual probes: Click on **[Import adjustment data]**.
11. Click on **[Next >]**.
 - The settings for the measuring cycle are displayed.

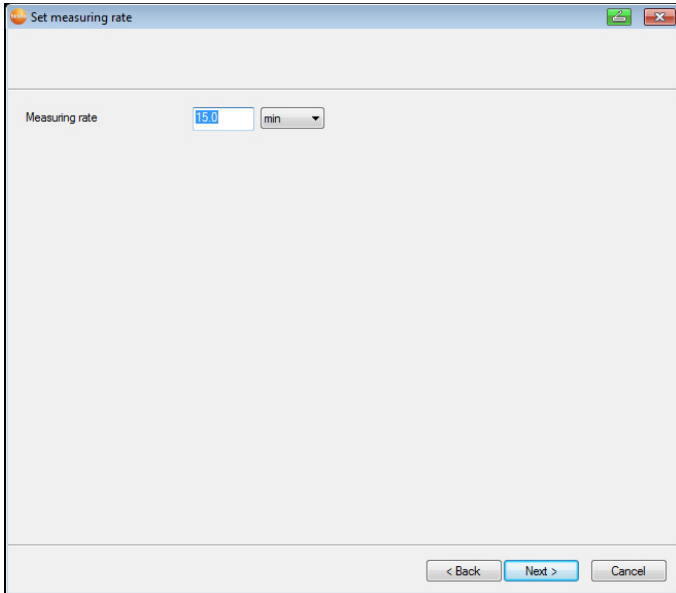

12. Enter **Measuring cycle** and define its **Unit**.



The measuring cycle determines the intervals at which a new measured value is saved in the Saveris base.

Possible settings for the unit:

- **sec** (second)
- **min** (minute)
- **h** (hour).

The smallest transfer rate for radio probes is one minute.

13. Click on **[Next >]**.

- If a router is registered on the Saveris base, the configuration of the connection type for the probes is shown.

If you have not registered a router, continue with step 17.

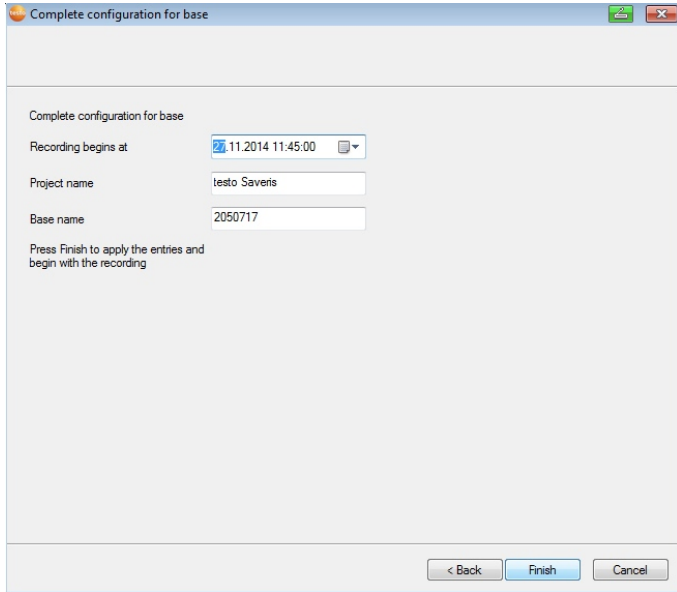

18. Postpone the start of measurement if necessary.
19. Click on **[Finish]** to end the hardware startup.
 - A message about the successful configuration of the hardware is displayed.
20. Confirm the message by clicking **[OK]**.
 - The new hardware is now ready to be used.

7.2.3. Logging components back in

i When logging components already logged into the current project back in, measuring values can be updated in the existing data column of the measuring value table or a new measuring value column can be set up.

1. Log the new probe into the Saveris base; see Connecting radio probe, page 49.
2. Start the testo Saveris startup wizard.
 - The startup wizard is opened.

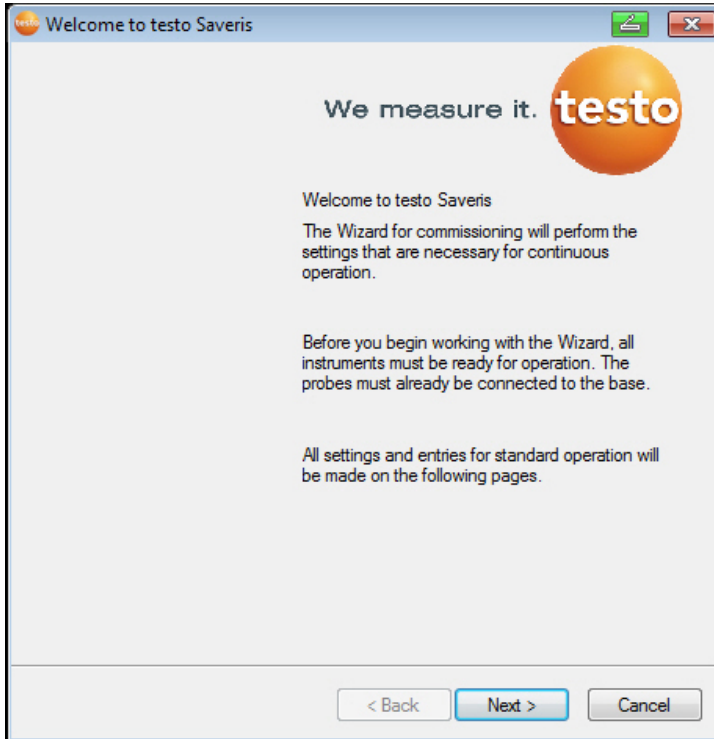

3. Click on **[Next >]**.
 - The software automatically detects whether the probe was already logged in and opens the **Commission New Probe** dialogue box.
4. In the **Connect [To]** column, select if the probe measuring values should be updated in the existing data column or
5. **[Off]** should be selected if the probe measuring values should be displayed in a separate data column.
6. Click on **[Next >]**.
 - The **Configure New Probe** dialogue box is displayed.

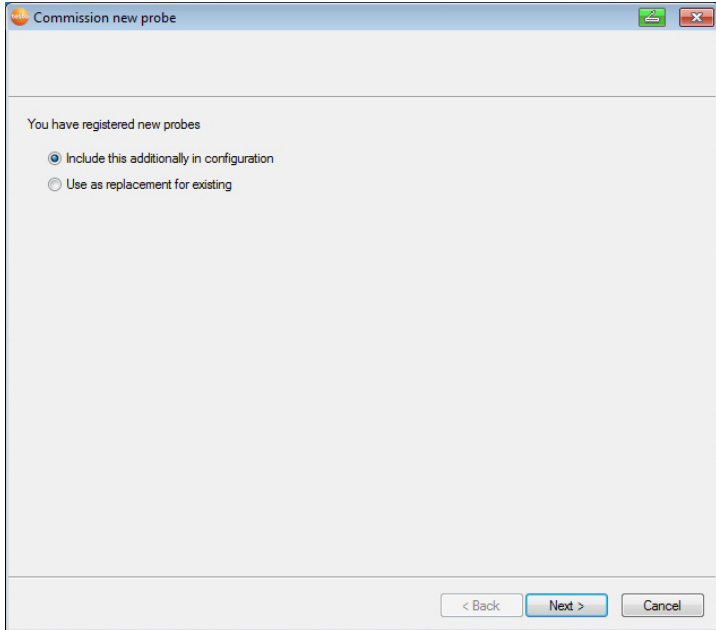

7. Click on **[Next >]** if the probe should also be included in the configuration or
8. Select **Replace Existing Probe** if the probe should replace another probe.
9. Click on **[Next]** and follow the instructions of the startup wizard.

i Note Further configuration is carried out in the same way as **Add New Component**, See also Adding new components, page **173**..

7.3. Calibration and adjustment

i **Calibration**

The comparison of a measured value with the correct value under specified conditions. This includes documentation of the deviation, correction of the measurement uncertainty and creation of the certificate. Calibration does not include adjustment of the measuring instrument.

Adjustment

A measuring instrument is used to measure a correct, known value (confirmed by a superordinate body). The

instrument is then adjusted to this value.

All testo Saveris probes are adjusted in the factory, which is confirmed by the corresponding adjustment report. Calibration certificates can be ordered separately, see **Accessories and spare parts** page 217.

For consistently reliable data, we recommend carrying out probe calibration and any necessary adjustment at regular intervals, e.g. every year. This can be implemented on or off site.

7.3.1. On-site calibration and adjustment

The Saveris adjustment software (article no. 0572 0183) is required for this.

Advantages: calibration while the system is running and simple documentation by adding an annotation, plus the importing of adjustment data

Disadvantages: accuracy or comparability of the reference system measurement data.

After successful adjustment, the current adjustment data is stored in the probe. At the same time, the adjustment software generates an adjustment file that can be imported into the Saveris software, see **Settings for the radio probe** page 161 and **Ethernet probes** page 163.



Ensure that an external humidity probe always remains attached to the radio or Ethernet probe with which it was adjusted.

7.3.2. External calibration and adjustment

Advantages: accuracy, via separate measurement as per a suitable calibration standard, e.g. in an air-conditioning cabinet.

Disadvantages: probe must be removed from running system.

Two different procedures may be used to carry out external calibration and adjustment.

Procedure 1

Here the probe removed from the system is not replaced, no measurement data is recorded during the calibration and adjustment.

1. Press the connect key on the probe once to enforce one last data transmission.
2. Send the probe to the calibration laboratory, without removing it as a component in the startup wizard.

3. When the system alarm “Missing probe connection” appears, acknowledge this once.
4. Once the probe comes back following calibration, link it back up with the base or the converter.
5. The probe automatically acquires its former configuration data and continues measuring.

Procedure 2

Here the probe removed from the system is temporarily replaced with another probe in order to retain measurement data even during the calibration and adjustment.

1. Register the replacement probe on the base.
2. Configure the replacement probe using the startup wizard. Here choose the option **Use as a replacement**.
3. Take replacement probe to the measuring point and wait for acclimatisation.
4. Press the connect key on both probes, one after the other.
 - Replacement is now complete (measurement data is supplied to the system via the replacement probe).
5. Carry out calibration and adjustment.
6. Register the probe on the base again.
7. Configure the probe using the startup wizard. Here, at **Connect** select the option **Off** and subsequently select the option **Use as a replacement**.
8. Take probe back to the measuring point and wait for acclimatisation.
9. Press the connect key on both probes, one after the other.
 - Replacement is now complete (measurement data is supplied to the system via the original probe once again).

7.4. Saving data in the Saveris base

- ✓ Saveris base is started up and connected to the PC.
1. Launch testo startup wizard.
 2. Enter IP address of the Saveris base.
 3. Click on **[Base backup]** on the **Projects** tab.
 - Message **For backup, the base must be restarted** is displayed. **Do not** confirm the message.
 4. Shut down the Saveris base: in the **Info Base** menu, press **[Esc]** briefly twice.
 5. Start up the Saveris base: press and hold down **[Esc]**.
 - Menu **Select language** appears.

i Do not press any other keys on the Saveris base.

6. Confirm software message **For backup, the base must be restarted** with **[OK]**.
 7. Select the directory to which the backup file should be saved.
 8. Click on **[Save]**.
- *bi2 file with backup data is saved.
-

i The stored data can only be imported to a Saveris base with the same firmware status. The memory capacity of the target base must be larger than or equal to the source base. For the memory size, see the **Select language** window.

i To transfer the saved data to a Saveris base, please contact Customer Service.

7.5. Restarting the Saveris base

i Only carry out these steps if they will resolve the problem indicated by the relevant alarm message, see Saveris base alarm messages, page **215**.

- ✓ The Saveris base display shows **Info Base**.
1. Press **[ESC]** twice in rapid succession.
 - **Shutdown** appears on the display and the Saveris base switches off.
 2. Press **[ESC]**.
 - The Saveris base is started.

7.6. Removing probe from wall bracket

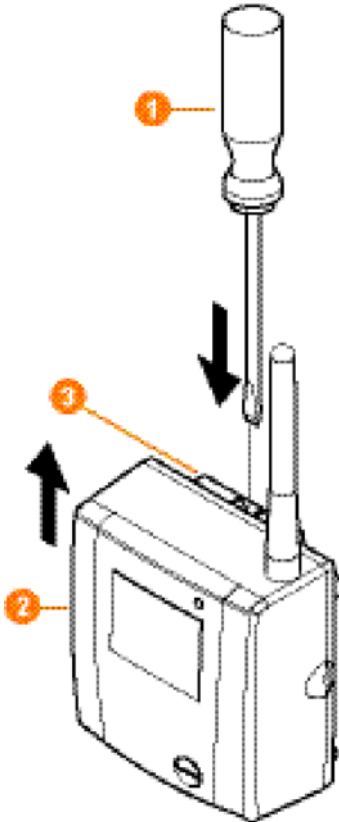

1. Using a narrow flat tip screwdriver ① release the probe ② from the wall bracket ③.
2. Remove probe from wall bracket towards top, as shown.

7.7. Changing batteries at probe

i Replace the batteries after 3 years of operation at the very latest.

i The battery life is (with a measuring cycle of 15 minutes)

- 3 years with standard AlMn batteries at +25 °C and
 - 3 years with Energizer L91 Photo lithium batteries
-

for freezer applications (for operation below -10°C).
 You can check the battery status of the probes via the Saveris software. Under **System | Radio probe**, select the probe you want to test. The current charge status is displayed in the **Battery status** field.

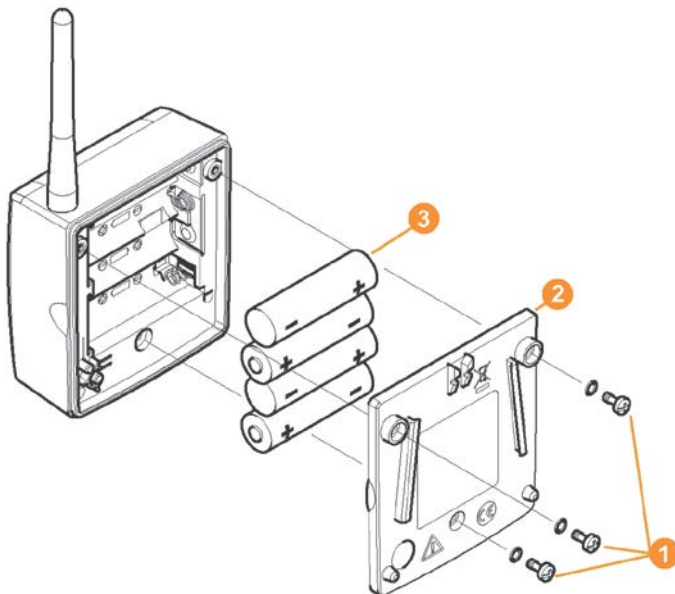

- > Remove probe from the wall mount; see "**Removing probe from wall bracket**".

i The probe must be at room temperature when the battery is changed, otherwise a build-up of moisture may impair the measuring accuracy.

1. Undo screws **1** on the back of the probe.
 2. Remove the probe housing cover **2**.
 3. Change batteries **3**.
-

i Ensure that you insert the batteries correctly.
 The correct polarity is illustrated in the respective battery compartment.

4. Refit the probe housing cover.
 5. Screw the cover tightly on to the housing.
-

i A control switch is located in the housing that is actuated through the cover. To do so, the cover must be

screwed to the probe housing without a gap.
If the control switch is not actuated through the cover,
the probe cannot be operated.



Caution! Unwanted residual discharge when disposing
of old batteries.

- > Mask the poles of the old batteries in order to
prevent unwanted residual discharge caused by
short circuits during disposal.
-



Transport note: If the probe is to be sent via air freight,
the batteries must be removed beforehand to avoid
inadvertent radio communication.

7.8. Changing a battery



The battery in the Saveris base, the Ethernet probes
and the analog coupler is a wearing part, which has to
be replaced after approx. 2 years.

If a battery is faulty, it is not possible to guarantee full
operability of the GSM module. In the event of a power
failure, data loss cannot be ruled out for all components.

When a component's battery is no longer fully
functional, it triggers a system alarm **Battery faulty**.

The battery (article no. 0515 0021) should then be
replaced immediately to ensure full functionality and
data security.

Saveris base

1. Switch off the Saveris base (with the **Info Base** view selected,
press **[ESC]** briefly twice).
2. Isolate the Saveris base from the power supply.
3. Undo the screw connection **①** and remove the base plate **②**
from the Saveris base.

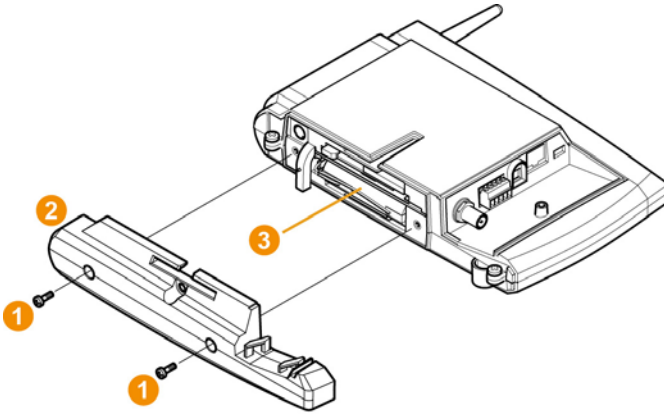

4. Replace the battery ③.
5. Place the base plate on the Saveris base and screw it down.
6. Plug the Saveris base into the power supply.
7. Switch on the Saveris base (hold down **[ESC]**).
 - Select language appears.
8. Select the required language (press **[Enter]**).
 - Saveris base starts up and is ready for operation.

Ethernet probe/analog coupler

i While the battery is being replaced, no measured values can be recorded.

- > Remove the component from the wall mount; see "**Removing probe from wall bracket**".

i The component must be at room temperature when the battery is changed, otherwise a build-up of moisture may impair the measuring accuracy.

1. Isolate the component from the power supply (mains plug/plug-in or screw terminal 24 V AC/DC/Ethernet cable (PoE)).
2. Undo screws ① on the back.
3. Remove the housing cover ②.

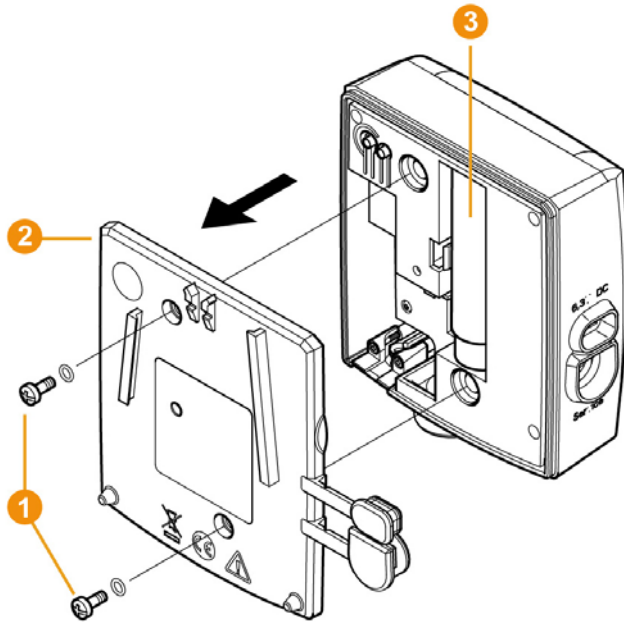

4. Replace the battery ③.
 5. Refit the housing cover.
 6. Screw the cover tightly on to the housing.
 7. Restore the power supply to the component (mains plug/plug-in or screw terminal 24 V AC/DC/Ethernet cable (PoE)).
- Component is ready for operation.

i A control switch is located in the housing that is actuated through the cover. The cover must be screwed to the housing without a gap.
If the control switch is not actuated through the cover, the component cannot be operated.

7.9. Carrying out a software and firmware system update

- i** - To make the most of the Saveris system performance, the system should be updated regularly.
 - Software and firmware updates should always be carried out together. For updates to versions up to 4.2 always begin with the software update. For updates to versions 4.3 and above always begin with the firmware update.
 - All software and firmware updates are available on the Testo website in the download centre or from our software hotline (softwarehotline@testo.de).
 - For further help carrying out the updates, contact our software hotline softwarehotline@testo.de
-

7.9.1. Carrying out a software update

- i** - The Saveris measuring and configuration data is retained during this process, as it is stored on the SQL Server®.
 - If MAPI or SMTP Mail is installed, the settings should be documented in the registry under HKeylokalmachine\software\testo\comsoft\tdasmail and the email components under the software should be uninstalled before the Saveris server uninstallation and reinstalled after the Saveris server installation.
 - If the storage path for your automated reports have been updated in the registry, these settings should be updated again in the registry.
 - After a Saveris CFR software update, the security settings in the software must be reconfigured. For this, please remove the old configuration settings, close the software, open it again and reassign the security settings in the 3 Testo groups.
-

Uninstall the older version of the Saveris client (Professional or CFR version) without uninstalling the database and then install the current server.

Uninstalling software

1. In Windows®, switch over to **Start – (Settings) – Control panel - Software** (Windows® XP).
2. In **Software**, click on **Testo Saveris Professional Server** and then **Edit/Remove**.
3. Select **Remove Program** and click on **Next**.
 - Software is uninstalled
4. Restart the PC

7.9.1.1. Software installation

1. On the Saveris CD, switch to the **TestoSaveris Prerequisites** directory.
2. Run the **setup.exe** file.
3. Restart the PC
 - Software has been updated

i If you are carrying out the update not from a CD but rather from a downloaded directory, copy the **TestoSaverisPrerequisites** directly under a root directory (e.g. C:\ or D:\) so that the call-up path of the setup file is as follows: C:\ TestoSaverisPrerequisites or D:\TestoSaverisPrerequisites

7.9.1.2. Installing the server

1. On the Saveris CD or in the directory tree, switch to the **TestoSaverisServer** directory.
2. Run the **setup.exe** file.
3. Restart the PC
 - Server has been updated

7.9.2. Carrying out a firmware system update

i With the firmware system update, all Saveris components (with the exception of the Saveris cockpit unit) in your system are updated automatically to the latest firmware status. This ensures that all components in your system show the current firmware version. Please note that a firmware update of Saveris cockpit units must be carried out separately.

Important information on the firmware system update

- Please note that, with the testo Saveris data monitoring system, two firmware system updates (**V1.X and V2.X**) are available. First check exactly which firmware update is valid for your system. You can check the compatibility of the firmware versions via the order number on your Saveris base's type plate
 - **Firmware System Update V1.X**
valid for Saveris systems with base article no. 0572 0120, 0572 0121, 0572 0160, 0572 0161
 - **Firmware System-Update V2.X**
valid for Saveris systems with base article no. 0572 0220, 0572 0221, 0572 0260, 0572 0261
- How long the firmware system update takes depends on the number of Saveris components in the system. Automatic distribution of the firmware to:
 - **Converter and extender** requires at least 3 minutes + 2 minutes per component for the standard communication cycle.
 - **Ethernet probe** requires at least 3 minutes + 2 minutes per component for the standard communication cycle.
 - **Router** requires at least 6.5 hours (all logged-in routers are updated in parallel).
 - **Radio probe** in stationary use requires at least 16 hours (all logged-in radio probes are updated in parallel).
- The Saveris base must be connected to the computer via USB or Ethernet cable.
- All Saveris components must have at least firmware version 1.12 for the update. System components with firmware version < V 1.12 can only be updated via service interface.
- For an update to version 4.3, the components must be equipped with the following firmware version as a minimum requirement:
 - For V1.x systems: software 4.2 SP3, base and radio probe V1.90, router, converter and extender V2.59, Ethernet probe V1.47
 - For V2.x systems: software 4.2 SP3, base and radio probe V2.59, router, converter and extender V2.59, Ethernet probe V1.47
- All outstanding alarms must be acknowledged by you before a firmware system update.
- **ATTENTION:** During the firmware update process, never disconnect the power supply/network supply and the PC connection.

- During the update, measurements, data storage and data communication are continued so there is no data loss.
- Configuration changes during the firmware system update should not be carried out to ensure that the process is not slowed.
- As there is heavy radio traffic during the update, alarms relating to interrupted radio links may occur temporarily.
- The reboot phase once a probe has been updated takes approx. 1-2 minutes. During this brief time, no measuring values can be recorded.

Carrying out an update

i Please note that the entire update process may take several hours. During this time, no configuration changes or network/power supply interruptions should occur.

1. Unpack the firmware file folder and save it to your PC.
 2. Open **Saveris Startup Wizard** and click in the **Projects** tab on **System Update**.
- A Windows® Explorer window **Search folder** is opened.

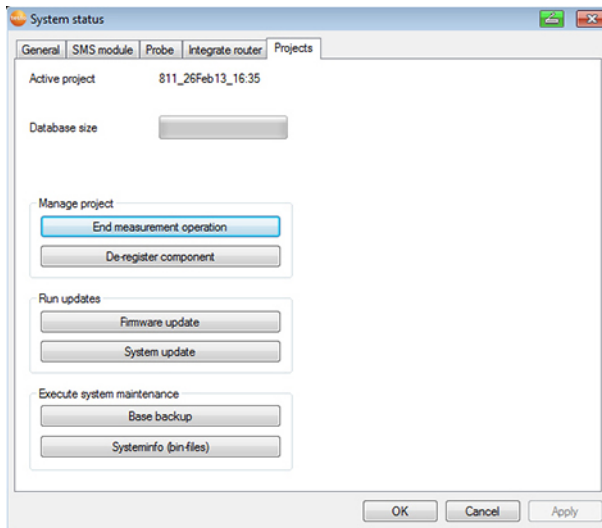

1. Select the destination directory to which you saved the downloaded folder.
 2. Confirm with **OK**.
- The information **The process has been completed successfully** is displayed after approx. 1 min.

3. Confirm with **OK**.
 - The Saveris startup wizard is closed automatically.
 - The firmware update for the Saveris base is imported.
 - The update process is completed as soon as the base starts up again and appears in the **Select language**.
4. Select the language on the base and confirm with **ENTER** or
5. Wait approx. 10 minutes until the Saveris base starts automatically.
 - The Saveris base firmware has been updated.
 - The update process for all other Saveris components in the system begins.



After the system update, the new firmware version is shown for each component in the Saveris software under the System menu item. The firmware version is only updated when the software is restarted.

7.9.3. Carrying out a Saveris cockpit unit firmware update

- Before a firmware update, all outstanding alarms must be acknowledged on the cockpit unit.
 - Terminate any tours that are running on the cockpit unit.
 - Disconnect the cockpit unit from the power supply and switch it off, or wait until it switches off automatically.
1. Plug the USB cable into the Saveris cockpit unit.
 2. Press and hold down the Up button on the Saveris cockpit unit.
 3. Connect to a PC/notebook using the USB cable.
 - Status LED on the cockpit unit lights up red.
 - The cockpit unit is displayed as a removable medium (**FWUPDATE**) in Windows® Explorer.
 4. Release the Up button on the Saveris cockpit unit.
 5. Open Windows® Explorer and click on **FWUPDATE**.
 6. Remove the file saved under **FWUPDATE**.
 7. Switch to the destination directory where you saved the downloaded new firmware file.
 8. Copy the new firmware file of the cockpit unit to the directory **FWUPDATE**.
 - The Saveris cockpit unit firmware update has been completed

7.10. Technical data

7.10.1. Saveris base

Characteristic	Values
Memory	40,000 values per channel (total max. 18,000,000 values)
Dimensions	225 x 150 x 49 mm
Weight	approx. 1510 g
Protection class	IP42
Housing material	Die-cast zinc/plastic
Radio frequency	868 MHz/2.4 GHz
Power supply	6.3 V DC mains unit; alternatively via 24 V AC/DC plug-in/screw terminals, power consumption < 4 W.
Rech. batt. ⁶	Li-ion battery The rechargeable battery is used only for backing up data and for emergency SMS in the event of failure of the power supply, not for the power supply during operation.
Operating temperature	+5 ... +45°C
Storage temperature	-25 ... +60°C
Display	graphical LCD display, 4 controls
Interfaces	USB, radio, Ethernet
Number of radio probes	Max. 15 probes can be connected directly via radio interface, max. 150 total via radio/router/converter/extender and Ethernet, max. 450 channels.
Alarm relay	max. 1 A, max. 30 W, max. 60/25 V DC/AC, NC or NO contact
GSM module	850/900/1800/1900 MHz

⁶ Wearing part

Characteristic	Values
Installation	Table base and wall bracket included
Warranty	2 years, for warranty conditions see web page www.testo.com/warranty

7.10.2. Saveris radio probe

General

The technical data listed in the following table are valid for all Saveris radio probes. Special data for the individual probe types can be found in the following sections.

Feature	Values
Housing dimensions (W x H x D)	80 x 85 x 38 mm
Length of antenna	81 mm
Weight	Approx. 220 g
Battery type	4 AA batteries
Battery life	Typical values with a measuring cycle of 15 min: 3 years at +25 °C 3 years with Energizer L91 Photo lithium batteries for freezer applications
Housing material	Plastic
Radio frequency	868 MHz/2.4 GHz
Measuring cycle	Standard 15 min (can be set from 1 min up to 24 h)
Storage temperature	-40 to +55 °C (incl. batteries)
Display (optional)	2-line LCD; 7 segments with symbols
Transmission distance	approx. 300 m free field at 868 MHz approx. 100 m free field at 2.4 GHz
Wall holder	Included
Warranty	2 years

Saveris T1/T1D radio probe

Feature	Values
Probe type	NTC
Measuring range	-35 to +50 °C
Accuracy	± 0.4 °C (-25 to +50 °C) ± 0.8 °C (remaining measuring range)
Resolution	0.1 °C
Protection class	IP68
Conformity with standards	DIN EN 12830
Operating temperature	-35 to +50 °C

Saveris T2/T2D radio probe

Radio probe with external probe connection and internal NTC, door contact



Feature	Values
Probe type (internal)	NTC
Measuring range (internal)	-35 to +50 °C
Accuracy (internal)	± 0.4 °C (-25 to +50 °C) ± 0.8 °C (remaining measuring range)
Resolution (internal)	0.1 °C
Probe type (external)	NTC
Measuring range (external)	-50 to +150 °C
Accuracy (external)	± 0.2 °C (-25 to +70 °C) ± 0.4 °C (remaining measuring range)
Resolution (external)	0.1 °C
Connection	NTC via mini-DIN socket, door contact connection cable included in delivery (1.80 m). The setting of the door contact switch effects the life.
Protection class	IP68 (with probe inserted or port sealed with rubber plug)
Conformity with standards	DIN EN 12830
Operating temperature	-35 to +50 °C

Saveris T3/T3D radio probe

2-channel radio probe with 2 external TC probe connections (TC characteristics can be selected)



Feature	Values
Probe type	TC
Measuring range	
TC type J	-100 to +750 °C
TC type K	-195 to +1350 °C
TC type S	0 to +1760 °C
TC type T	-200 to +400 °C
Accuracy	±0.5 °C or 0.5% of measured value (25 °C)
Resolution	0.1 °C/TC type S 1 °C
Connection	2 TCs via TC socket, max. difference in potential 2 V
Protection class	IP54 (with probe inserted or port sealed with rubber plug)
Operating temperature	-20 to +50 °C

i The probe inputs are not isolated from one another. Take this into account when using probes with non-isolated thermocouple.

Saveris Pt/PtD radio probe

Radio probe with an external Pt100 probe connection



Feature	Values
Probe type	Pt100
Measuring range	-200 to +600 °C
Accuracy	±0.1 °C (0 to +60 °C) ±0.2 °C (-100 to +200 °C) ±0.5 °C (remaining measuring range) at 25 °C
Resolution	0.01 °C
Connection	1 Pt100 via mini-DIN socket
Protection class	IP 68
Operating temperature	-20 to +50 °C

Saveris H3/H3D radio probe

Humidity radio probe



Feature	Values	
Probe type	NTC	Humidity sensor
Measuring range	-20 to +50 °C	0 to 100%RH ⁷
Accuracy	± 0.5 °C	± 3%RH at +25 °C ± 0.03%RH/K ±1 digit
Resolution	0.1 °C/0.1 °Ctd	0.1%
Protection class	IP 42	
Operating temperature	-20 to +50 °C	

Saveris H2D radio probe

Humidity radio probe



Feature	Values	
Probe type	Humidity sensor	NTC
Measuring range	0 to 100%RH ⁸	-20 to +50 °C

Feature	Values	
Accuracy	< 90%RH: $\pm 2\%RH$ at +25 °C > 90%RH: $\pm 3\%RH$ at +25 °C $\pm 0.03\%RH/K \pm 1$ digit	± 0.5 °C
Resolution	0.1%/0.1 °Ctd	0.1 °C
Protection class	IP 54	
Weight	Approx. 256 g	

Saveris H4D radio probe

Humidity radio probe



Feature	Values	
Probe type	Humidity sensor	NTC
Measuring range	0 to 100%RH ⁹	-20 to +70 °C
Accuracy	see external probes	± 0.2 °C
Resolution	0.1%/0.1 °Ctd	0.1 °C
Protection class	IP 54	
Weight	Approx. 254 g	

⁸ Not for non-dewing atmosphere. For constant use in high humidity (> 80% RH at ≤ 30 °C for > 12 h, > 60%RH at > 30 °C for > 12 h),

⁹ Not for non-dewing atmosphere. For constant use in high humidity (> 80% RH at ≤ 30 °C for > 12 h, > 60%RH at > 30 °C for > 12 h),

Feature	Values
Connection	1x humidity/temperature probe (\varnothing 12 mm or \varnothing 4 mm) via mini-DIN socket

External probes

Feature	Values	
Probe type	Humidity/temperature probe \varnothing 12 mm	Humidity/temperature probe \varnothing 4 mm
Measuring range	-20 to +70 °C 0 to +100%RH	0 to +40 °C 0 to +100%RH
Accuracy	\pm 0.3 °C \pm 2%RH at+25 °C (2 to 98%RH) \pm 0.03%RH/K \pm 1 digit	\pm 0.3 °C \pm 2%RH at+25°C (2 to 98%RH) \pm 0.08%RH/K \pm 1 digit

7.10.3. Saveris router



Characteristic	Values
Housing dimensions (W x H x D)	80 x 100 x 38 mm
Length of antenna	81 mm
Weight	approx. 180 g
Power supply	6.3 V DC mains unit; alternatively via 24 V AC/DC plug-in/screw terminals, power consumption < 5 W
Housing material	Plastic

Protection class	IP54
Operating temperature	-20 - +50 °C
Storage temperature	-40 - +60 °C
Interfaces	Radio
Number of radio probes	max. 5; in a router cascade, max. 3
Wall mount	included

7.10.4. Saveris Ethernet probes

The technical data listed in the following table are valid for all Saveris Ethernet probes. Special data for the individual probe types can be found in the following sections.

Feature	Values
Housing dimensions (W x H x D)	85 x 100 x 38 mm
Power supply	6.3 V DC mains unit; alternatively via 24 V AC/DC plug-in/screw terminals, PoE
Buffer battery ¹⁰	Li-ion
Housing material	Plastic
Protection class	IP54
Measuring cycle	2 sec - 24 h
Operating temperature	+5 ... +45 °C
Storage temperature	- 25 ... +60 °C
Display (optional)	2-line LCD; 7 segments with symbols
Wall holder	Included
Power consumption	PoE class 0 (typically ≤ 3 W)
Warranty	2 years

¹⁰ Wearing part

Saveris PtE Ethernet probe

Ethernet probe with external Pt100 probe connection



Feature	Values
Probe type	Pt100
Measuring range	-200 to +600 °C
Accuracy	± 0.1 °C (0 to +60 °C) ± 0.2 °C (-100 to +200 °C) ± 0.5 °C (remaining measuring range) at 25 °C
Resolution	0.01 °C
Connection	Mini-DIN service interface is accessible externally 1 Pt100 via mini-DIN socket
Weight	Approx. 220 g

Saveris T1E Ethernet probe

Ethernet probe with external NTC probe connection



Feature	Values
Probe type	NTC
Measuring range	-50 to +150 °C
Accuracy	± 0.2 °C (-25 to +70 °C) ± 0.4 °C (remaining measuring range)
Resolution	0.1 °C
Connection	Mini-DIN service interface is accessible externally 1 NTC via mini-DIN socket

Weight	Approx. 220 g
--------	---------------

Saveris H4E Ethernet probe

Humidity Ethernet probe



Feature	Values	
Probe type	Humidity sensor	NTC
Measuring range	0 to 100%RH ¹¹	-20 to +70 °C
Accuracy	see external probe	± 0.2 °C
Resolution	0.1%/0.1 °Ctd	0.1 °C
Protection class	IP 54	
Weight	Approx. 254 g	
Connection	1x humidity/temperature probe (∅ 12 mm or ∅ 4 mm) via mini-DIN socket	

External probes

Feature	Values	
Probe type	Humidity/temperature probe ∅12 mm	Humidity/temperature probe ∅4 mm
Measuring range	-20 to +70 °C 0 to +100%RH	0 to +40 °C 0 to +100%RH
Accuracy	± 0.3 °C ± 2%RH at+25 °C (2 to 98%RH) ± 0.03%RH/K ±1 digit	± 0.3 °C ± 2%RH at+25 °C (2 to 98%RH) ± 0.08%RH/K ±1 digit

¹¹ Not for non-dewing atmosphere. For constant use in high humidity (> 80% RH at ≤ 30 °C for > 12 h, > 60%RH at > 30 °C for > 12 h),

Saveris T4E Ethernet probe

4-channel Ethernet probe with 4 external TC probe connections



Feature	Values
Probe type	TC
Measuring range	
TC type S	0 to +1760 °C
TC type T	-200 to +400 °C
TC type J	-100 to +750 °C
TC type K	-195 to +1350 °C
Accuracy	±0.5 °C or 0.5% of measured value
Resolution	0.1 °C/TC type S 1 °C
Connection	Mini-DIN service interface is accessible externally 4 TCs via TC socket, max. difference in potential 50 V
Weight	Approx. 220 g

i The technical data refer to the probe in a stable, stationary operating mode. To receive a stable measurement the probe must be in operation for one to two hours.

i The usage of isolate thermocouples is recommended for supplying the Ethernet probe. Otherwise discrepancies in readings of up to 0.6 °C may occur due to leakage currents.

H2E Ethernet probe

Humidity Ethernet probe, 2%



Feature	Values	
Probe type	Humidity sensor	NTC
Measuring range	0 to 100%RH ¹²	-20 to +70 °C
Accuracy	< 90%RH: ± 2%RH at +25 °C > 90%RH: ± 3%RH at +25 °C ± 0.03%RH/K ± 1 digit	± 0.5 °C
Resolution	0.1%RH/0.1 °Ctd	0.1°C
Connection	Mini-DIN service interface is accessible externally	
Weight	Approx. 230 g	

¹² Not for non-dewing atmosphere. For constant use in high humidity (> 80% RH at ≤ 30 °C for > 12 h, > 60%RH at > 30 °C for > 12 h),

H1E Ethernet probes

Humidity Ethernet probe, 1%



Feature	Values	
Probe type	Humidity sensor	NTC
Measuring range	0 to 100%RH ¹³	-20 to +70 °C
Accuracy	< 90%RH: ± 1%RH (+0.7% of measuring value) at 25 °C > 90%RH: ± 1.4%RH (+0.7% of measuring value) at 25 °C ± 0.03%RH/K ±1 digit	±0.2 °C (0 to +30 °C) ±0.5 °C (remaining measuring range)
Resolution	0.1%RH/0.1 °Ctd	0.1 °C
Connection	Mini-DIN service interface is accessible externally	
Weight	Approx. 230 g	

¹³ Not for non-dewing atmosphere. For constant use in high humidity (> 80% RH at ≤ 30 °C for > 12 h, > 60%RH at > 30 °C for > 12 h),

7.10.5. Saveris converter



Characteristic	Values
Housing dimensions (W x H x D)	80 x 100 x 35 mm
Length of antenna	81 mm
Weight	approx. 190 g
Power supply	6.3 V DC mains unit; alternatively via 24 V AC/DC plug-in/screw terminals, PoE, power consumption < 2 W
Housing material	Plastic
Protection class	IP54
Operating temperature	-20 to +50 °C
Storage temperature	-40 to +60 °C
Interfaces	Radio, Ethernet
Number of radio probes	max. 15
Wall mount	included

7.10.6. Saveris cockpit unit¹⁴

Feature	Values
Memory	20,000 measured values
Dimensions	150 x 90 x 40 mm
Weight	Approx. 210 g
Protection class	IP30
Housing material	Plastic
Radio frequency	868 MHz
Power supply	Mini USB cable, incl. adapter, for 12/24 V DC power supply via the cigarette lighter
Rech. batt.	NiMH battery The rechargeable battery is only intended to be used for backing up data in the event of a power failure, not as a power supply during operation.
Operating temperature	-30 to +65°C
Storage temperature	-40 to +85°C
Display	Graphical LCD display
Interfaces	USB, radio, infrared for Testo printers
Number of radio probes	Max. 2 zones each with 4 radio probes (max. 32 channels)

¹⁴ This component is only permitted for mobile monitoring in countries with a radio frequency of 868 MHz.

Feature	Values
Installation	Wall mount with sucker and telescopic function included
Warranty	2 years, for warranty conditions see web page www.testo.com/warranty

7.10.7. Saveris extender¹⁵



Feature	Values
Housing dimensions (W x H x D)	80 x 100 x 35 mm
Length of antenna	81 mm
Weight	Approx. 190 g
Power supply	6.3 V DC mains unit; alternatively via 24 V AC/DC plug-in/screw terminals, PoE, power consumption < 2 W
Housing material	Plastic
Protection class	IP54
Operating temperature	-20 to +50°C
Storage temperature	-40 to +60°C
Interfaces	Radio, Ethernet
Number of radio probes	max. 100

¹⁵ This component is only permitted for mobile monitoring in countries with a radio frequency of 868 MHz. Saveris extender cannot be operated via VPN.

Radio frequency	868 MHz
Wall mount	Included

7.10.8. Saveris analog coupler

Saveris U1 radio analog coupler



Characteristic	Values
Measuring range	2-wire: 4 to 20 mA 4-wire: 0/4 to 20 mA, 0 to 1/5/10 V
Accuracy/resolution (max. 15 bit/typ. 12 bit)	Current accuracy: ± 0.03 mA (min. 0.75 μ A/typ. 5 μ A) Voltage 0 to 1 V ± 1.5 mV (min. 39 μ V/typ. 250 μ V) Voltage 0 to 5 V ± 7.5 mV (min. 0.17 mV/typ. 1.25 mV) Voltage 0 to 10 V ± 15 mV (min. 0.34 mV/typ. 2.50 mV) ± 0.02 % of reading/K (deviation from nominal temperature 22 °C)
Input	2 or 4-conductor current/voltage input
Channels	1-channel
Max. load (24 V DC)	160 Ω
Protection class	IP54
Power supply	Mains unit 6.3 V DC, 20 to 30 V DC max. 25 V AC
Buffer battery ¹⁶	Li-ion
Operating temperature	+5 ... +45 °C

¹⁶ Wearing part

Characteristic	Values
Housing dimensions (W x H x D)	85 x 100 x 38 mm
Weight	approx. 240 g
Housing material	Plastic
Radio frequency	868 MHz/2.4 GHz
Meas. cycle	Can be set from 1 min to 24 h
Warranty	2 years, for warranty conditions see web page www.testo.com/warranty

Saveris U1E Ethernet analog coupler



Characteristic	Values
Measuring range	2-wire: 4 to 20 mA 4-wire: 0/4 to 20 mA, 0 to 1/5/10 V
Accuracy/resolution (max. 15 bit/typ. 12 bit)	Current accuracy: ± 0.03 mA (min. 0.75 μ A/typ. 5 μ A) Voltage 0 to 1 V ± 1.5 mV (min. 39 μ V/typ. 250 μ V) Voltage 0 to 5 V ± 7.5 mV (min. 0.17 mV/typ. 1.25 mV) Voltage 0 to 10 V ± 15 mV (min. 0.34 mV/typ. 2.50 mV) ± 0.02 % of reading/K (deviation from nominal temperature 22 °C)
Input	2 or 4-conductor current/voltage input
Channels	1-channel
Max. load (24 V DC)	160 Ω
Protection class	IP54
Power supply	Mains unit 6.3 V DC, PoE, 20 to 30 V DC max. 25 V AC, PoE

Characteristic	Values
Operating temperature	+5 ... +45 °C
Housing dimensions (W x H x D)	85 x 100 x 38 mm
Weight	approx. 240 g
Housing material	Plastic
Meas. cycle	Can be set from 2 sec to 24 h
Warranty	2 years,

8 Tips and assistance

8.1. Questions and answers

Question	Possible causes/solution
The converter does not transfer any data to the base.	<p>The cable connection to the converter is faulty.</p> <ul style="list-style-type: none"> > Remove the power supply and check whether the Ethernet cable is connected correctly. > Reconnect the power supply. - The converter checks its configuration and if it detects an error, it resets all values to the factory settings.
Cockpit unit does not print	<p>The cockpit unit power supply has been interrupted.</p> <ul style="list-style-type: none"> > Restore the power supply to the cockpit unit. > Restart printing.
Cockpit unit printout is terminated	<p>The cockpit unit power supply has been interrupted.</p> <ul style="list-style-type: none"> > Restore the power supply to the cockpit unit. > Restart printing.

8.2. Saveris base alarm messages

Alarm message	Possible causes/solution
L_CommUp L_CommApp	<p>Error during USB or Ethernet initialisation.</p> <ul style="list-style-type: none"> > Disconnect all links to the base. > Reconnect all links. > Restart the base.
L_GSM L_GSMMenu	<p>Error during GSM modem initialisation.</p> <ul style="list-style-type: none"> > Check the GSM module's battery power. > Restart the base.

Alarm message	Possible causes/solution
L_RF2010Server L_RF2010IO L_RF2010MemPool L_RF2010StreamRip L_UDPRF2010	Error during radio module initialisation. Reboot the base. If the problem persists, contact the Service team. > Restart the base. If the problem persists, please contact testo Service.
L_UIPrio L_DispDrvUI,	Error loading the UI/display. Reboot the base. > Restart the base.
L_MemoryMgmt	Error loading memory management. > Contact testo Service.
L_AlarmCtrl L_AlarmCfg	Error loading the alarm controller. > Contact testo Service.
L_FileSysChk L_FileSys L_AccelFileSys	Error loading the mass storage device. > Contact testo Service.
L_EventLog L_AlarmLog L_TourLog L_ErrorLog L_GsmStatLog	Error loading a log. > Contact testo Service.
L_RFTest2010	Error testing the radio module. > Contact testo Service.
L_BaseConf L_LowElement L_UppElement	Error loading basic functionality. > Contact testo Service.
L_Group L_TourCard	Error loading the fundamentals for mobile zones. > Contact testo Service.

8.3. Accessories and spare parts

Description	Article no.
Spare batteries for radio probes (4 x AA alkali manganese Mignon batteries)	0515 0414
Spare batteries for radio probes for operation below -10 °C (Energizer L91 Photo lithium)	0515 0572
Replacement battery for Saveris base, Ethernet probe and analog coupler	0515 0021
Mains unit 100-200 V DC; for Saveris base, router, converter, Ethernet probe	0554 1096
Mains unit (top-hat rail mounting) 90 to 240 V AC / 24 V DC (2.5 A)	0554 1749
Mains unit (desktop instrument) 90 to 240 V AC / 24 V DC (350 mA)	0554 1748
Adapter (from mini-DIN to USB) for base, Ethernet probe, converter and extender for the configuration of IP addresses and for the adjustment of the wireless and Ethernet probes.	0440 6723
Antenna with magnetic base with 3 m cable for base with GSM module	0554 0524
Antenna with magnetic base (quad band) for Saveris base with GSM module	0554 0525
Alarm module (visual & acoustic), can be connected to alarm relay, Ø 700 x 164 mm, 24 V AC/DC/320 mA, steady red light, continuous tone: buzzer approx. 2.4 kHz	0572 9999 ID-No. 0699 6111/1
Saveris protective housing for protection from high-pressure cleaning and impact, IP 69 K suitable for wireless probes T1/T1D/T2/T2D/Pt/PtD/H4D	0572 0200
Testo fast printer with wireless infrared interface, 1 roll of thermal paper and 4 Mignon batteries for printing out measured values on Saveris cockpit unit	0554 0549
testo Saveris SBE software, incl. USB cable for connection of the Saveris base to the computer	0572 0180

Description	Article no.
testo Saveris PROF software, incl. USB cable for connection of the Saveris base to the computer	0572 0181
Saveris adjustment software	0572 0183
Saveris CFR software, incl. Ethernet connecting cable PC - base	0572 0182
ISO temperature calibration certificate; temperature probe; calibration points - 8 °C; 0 °C; +40 °C per channel/device (suitable for Saveris T1/T2)	0520 0171
ISO temperature calibration certificate; temperature probe; calibration points - 18 °C, 0 °C, +60 °C; per channel/device (not suitable for Saveris T1/T2)	0520 0151
DAkks ¹⁷ temperature calibration certificate; temperature probe; calibration points -20 °C, 0 °C, +60 °C; per channel/device	0520 0261
ISO humidity calibration certificate; humidity probe; calibration points 11.3% RH and 75.3% RH at +25 °C; per channel/device	0520 0076
DAkks humidity calibration certificate; humidity probe; calibration points 11.3% RH and 75.3% RH at +25 °C; per channel/device	0520 0246

¹⁷ Successor organisation of the DKD (German calibration service)