

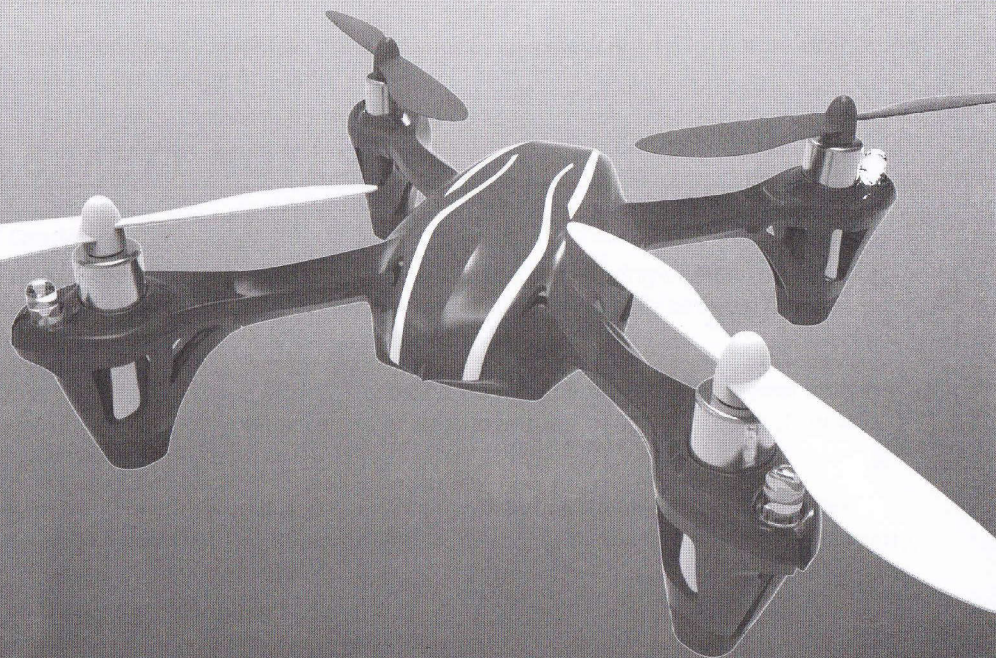

INSTRUCTION MANUAL



THE HUBSAN X4 No.H107
2.4GHZ RC SERIES 4 CHANNEL FLYING INDOOR AND OUTDOOR

Flip tips kindly check page 12-14

1 INTRODUCTION

Thank you for buying HUBSAN products. The quadcopter is designed as an easy to use, full featured RC model capable of hovering, fast forward, and aerobatic flight maneuvers. Please read the manual carefully and follow all instructions in this. Be sure to retain the manual for future reference, routine maintenance, and tuning.

1.1 Important Notes

This RC quadcopter is not a toy, it utilizes various high-techs to provide superior performance.

Please read this manual carefully before operating this product. Any improper use of this product will result in serious injury. Be aware of your personal safety, safety of others and your surrounding environment.

We recommend that you obtain the assistance of an experienced pilot before attempting to fly our product for the first time.

2 SAFETY NOTES

2.1 Caution

R/C quadcopter have parts that move at high speed, thus posing a certain degree of danger. Pilots are responsible for any actions resulting in damage or injury from the improper operation of their R/C aircraft models.

Choose a wide open space without obstacles. Do not operate R/C aircraft near buildings, crowds of people, high voltage cables, or trees to ensure the safety of yourself, others and your model.

Operate this unit within your ability. Do not fly when tired or after drinking or when impaired by medication. Improper operation may cause damage to people and property.

2.2 LiPo Battery Recharging

Your quadcopter is powered by a Lithium-Polymer (LiPo) battery.

Never recharge your battery whilst it is inserted in your model. It can catch fire leading to the total destruction of the item.

If you do not plan to fly your model for a week or more, store the battery approximately 50% charged to maintain battery performance and life. To achieve a 50% charge, fly the model until the battery requires recharging. Charge the battery for half the time typically required to fully charge the battery.



SAFETY ADVISORY NOTICE

[Lithium-Polymer (LiPo) Batteries]

LiPo batteries are different from conventional batteries in that their chemical contents are encased in a relatively insubstantial foil packaging. This has the advantage of significantly reducing their weight, but does make them more susceptible to damage if roughly or inappropriately handled. As with all batteries, there is a risk of fire or explosion if safety practices are ignored:

- ☑ Charge and store LiPo batteries in a location where a battery fire or explosion (including smoke hazard) will not endanger life or property.
- ☑ Keep LiPo batteries away from children and animals.
- ☑ Consider how you would deal with a LiPo battery fire/explosion as part of your normal home Fire Safety & Evacuation Planning.
- ☑ Never charge the LiPo battery that has ballooned or swelled due to over-/under-charging or from a crash.
- ☑ Never charge the LiPo battery that has been punctured or damaged in a crash (After a crash, inspect the battery pack for the sign of damage. Discard in accordance with your country's recycling laws.).
- ☑ Never charge the LiPo battery in a moving vehicle.
- ☑ Never over charge the LiPo battery.
- ☑ Never leave the LiPo battery unattended during recharging.
- ☑ Do not charge LiPo batteries near flammable materials or liquids.
- ☑ Ensure that charging leads are connected correctly. Reverse polarity charging can lead to battery damage or a fire or explosion.
- ☑ Have a suitable fire extinguisher (electrical type) OR a large bucket of dry sand near the charging area. Do not try to extinguish electrical (LiPo) battery fires with water.
- ☑ Reduce risks from fire/explosion by storing and charging LiPo batteries inside a suitable container: a LiPo Sack or metal/ceramic container is advised.
- ☑ Monitor recharging LiPo batteries for signs of overheating.
- ☑ Protect your LiPo battery from accidental damage during storage and transportation. (Do not put battery packs in pockets or bags where they can short circuit or can come into contact with sharp or metallic objects.).
- ☑ If your LiPo battery is subjected to a shock (such as a helicopter crash) you should place it in a metal container and observe for signs of swelling or heating for at least 30 minutes.
- ☑ Do not attempt to disassemble or modify or repair the LiPo battery.

2.3 Prevent Moisture

R/C models are composed of many precision electrical components.

Store the battery and model in a dry area at room temperature. Exposure to water or moisture may cause the model to malfunction resulting in loss of responsiveness, or a crash.

2.4 Proper Operation

For the safety purpose, please only use Hubsan's spare parts for replacement.

2.5 Always Be Aware Of The Rotating Blades

When in operation, the main and tail rotor blades will be spinning at high speed. The blades are capable of inflicting serious body injury and damage to the environment.

Be cautious of your actions and careful to keep your body and loose clothing away from the blades. Never take your eyes off the model or leave it unattended while it is turned on. Stop operation immediately if the model flies out of your view. Once landed, immediately turn off the model and transmitter.

2.6 Avoid Flying Alone

Beginners should avoid flying alone whilst learning flight skills. It is advised that an experienced pilot be in nearby guidance.

3 SAFETY CHECK BEFORE FLYING

CAREFULLY INSPECT THE X4 BEFORE EVERY FLIGHT

- Before operation, please check the batteries of the transmitter and receiver are charged enough for the flight.
- Before turning on the transmitter, please check that the throttle stick is in the full down position.
- Carefully check rotor blades and rotor holders. Broken or premature failure of parts will result in a dangerous situation.
- Check the battery and power plug are securely fastened. Vibration and violent flight may lead the plug to loose and result in loss of control.
- When turning on the unit, please follow the power on/off procedure: for Power ON- please turn on the transmitter first, and then turn on the receiver. For Power OFF- please turn off the receiver first and then turn off the transmitter. Improper procedure may cause loss of control of the quadcopter.

4 TRANSMITTER

4.1 Identification and functions of the Main Menu

Main Menu

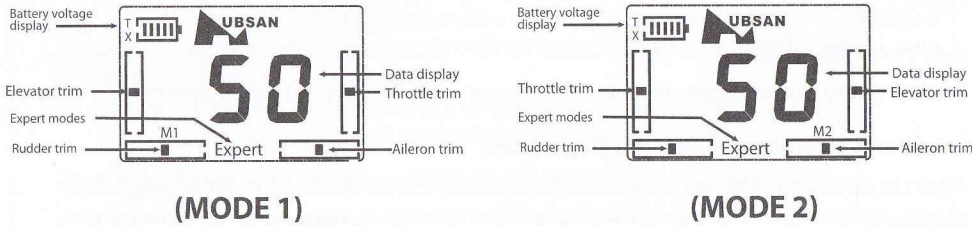

TRANSMITTER

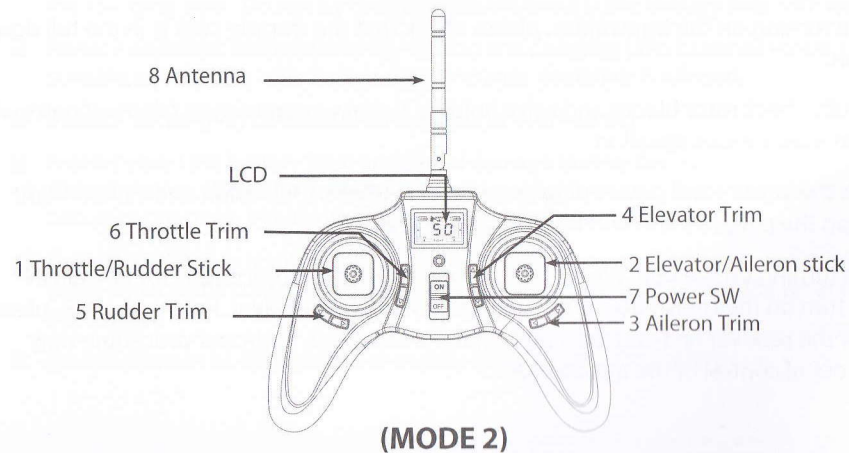
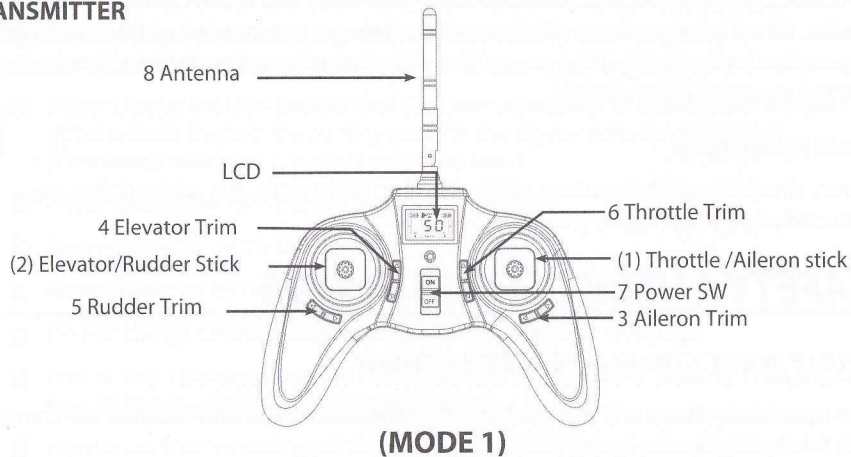

Input Key Function

S/N	Identification	Function
1	MODE 2 Throttle/Rudder Stick	Forward and backward movement of the stick makes the quadcopter ascend and descend respectively. Left and right movement of the stick will rotate the quadcopter's fuselage left/right respectively.
2	MODE 2 Elevator/Aileron Stick	Forward and backward movement of the stick makes the quadcopter move forward and backward respectively. Left and right movement of the stick makes the quadcopter drift sideways left/right respectively.
(1)	MODE 1 Throttle /Aileron stick	Forward and backward movement of the stick will make the quadcopter increase or decrease speed respectively. Left and right movement of the stick makes the quadcopter roll left/right to initiate a banked turn.
(2)	MODE 1 Elevator/Rudder Stick	Forward and backward movement of the stick makes the quadcopter nose point up/down respectively. Left and right movement of the stick makes the quadcopter yaw left/right respectively.
3	Aileron Trim	Aileron trim adjusts for left and right drift.
4	Elevator Trim	Elevator trim adjusts for forward and backward drift.
5	Rudder Trim	Rudder trim adjusts for drift of left and right rotation or yaw.
6	Throttle Trim	Throttle trim normally left at neutral. The lower trim turns LEDs on and off.
7	Power SW	Pushing the switch up turns on the transmitter. Pushing it down turns it off.
8	Antenna	Transmits the wireless 2.4 Ghz signal.

4.2 Battery Mounting

- Notice:** >Do not mix old and new batteries
>Do not mix different types of batteries
>Do not charge non-rechargeable battery.

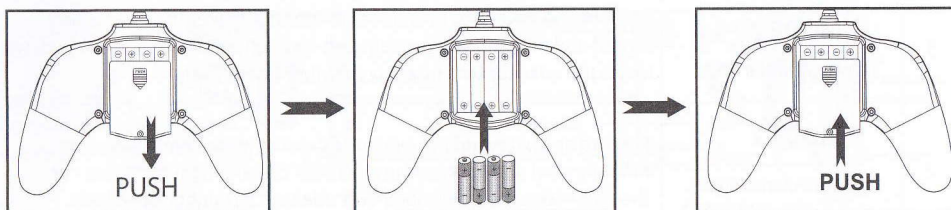

Take out the cover

Install 4 x AAA battery according to the correct polarities

Return the cover

5 LI-PO BATTERY CHARGING

5.1 The quadcopter equipped with a 3.7V 240mAh Lipo battery

5.1.1 Take out the battery from bottom of the X4

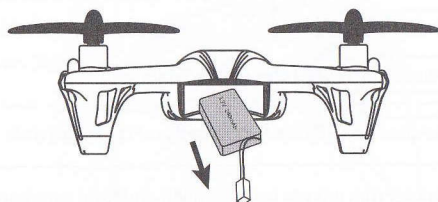

5.1.2 Connect the battery with USB charger, the LED light is ON whilst charging and turns OFF when charging complete.

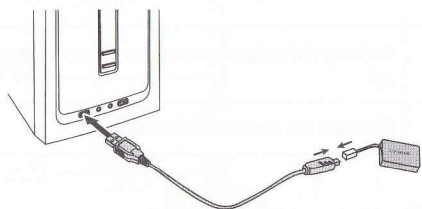

5.2. Please refer to 2.2. Safety Advisory Notice

Always partially charge your LiPo battery before storage. LiPo batteries retain the power over a reasonable period; it is not normally necessary to recharge stored LiPo batteries unless stored for periods longer than 3-6 months.

If your LiPo battery has been over-discharged, it will not be possible to recharge it again.



LiPo Battery Disposal & Re-Cycling



Lithium-Polymer (LiPo) batteries must not be placed in with household refuse. Please contact your Local Authority (Council) or the supplier of your model for local regulations and the location of your nearest LiPo battery recycling centre.

TEMPORARY STORAGE of DAMAGED LiPo BATTERIES:

Bury the LiPo battery in a bucket of dry sand or (if discharged) the battery may be neutralized by immersion in a salt water bath. If in doubt: always seek expert advice!

6 START TO FLY

6.1 Power-On (Failsafe) Procedure

Your X4's flight controller is coded with a Power-On failsafe.

This is designed to ensure that the X4's motor will not start unless it detects a suitable radio-control signal when the LiPo battery is connected. The correct Start-Up sequence is as follows:

6.1.1 Make sure the throttle stick is in the full down position.

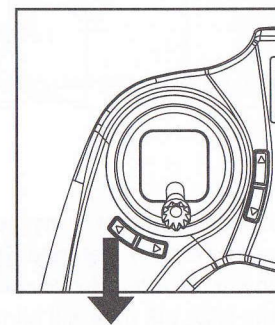

6.1.2 Power on the transmitter and the red LED will be blinking. Please do not move any other stick or trim before the TX and X4 match code and bind, or the X4 will drift. The TX LED will turn green when the TX binds with the X4.

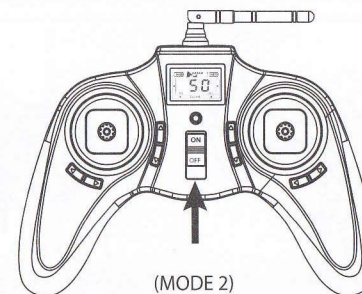

6.1.3 Apply power on the X4 by connecting the battery plug with correct polarity. Please disconnect the X4 battery plug after turning off the TX when you stop flying.

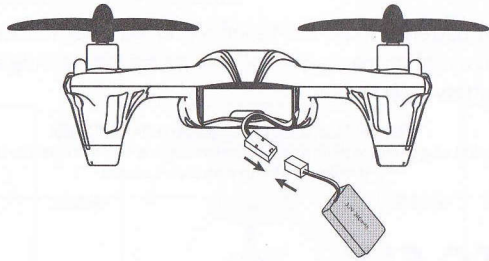

6.1.4 Insert the battery to the bottom of your X4. Make sure the battery and wires are pushed into the end of the battery compartment, so they will not negatively affect the center of gravity(COG) and cause unstable flight. **Please twist the wires and squeeze them into the notched holder as the picture shows, to prevent inflight shaking or oscillations.**

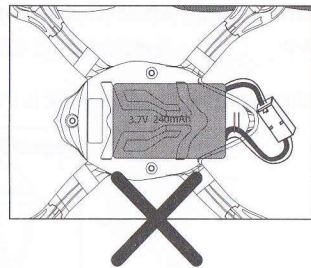
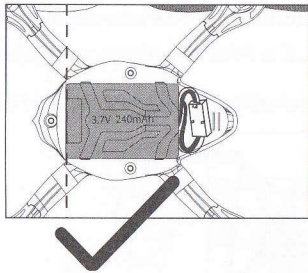

6.1.5 About LED lights:

After a "beep", and the red LED on the transmitter turns green, the 6 lights on the X4 will be on solid indicating that the bind code is matched. The LEDs will be on and night flying is possible. Press the lower throttle trim for about 1 second to turn the LEDs on or off. Even if you select the LEDs off, they will blink when the lipo power is low. **NOTE: The LEDs will blink when the quadcopter runs out of power or the X4 code does not bind with the TX.**

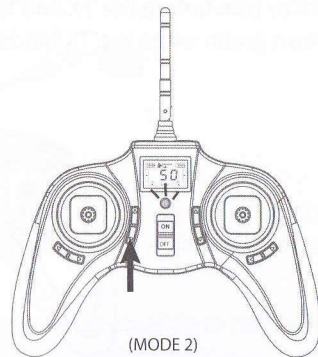
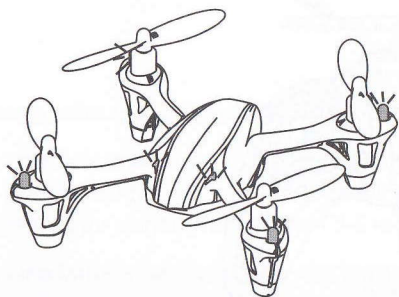

Tip: You do not need to adjust the rudder trim if the X4 keeps yawing left or right during flight. The X4 will find the rudder central point automatically in 3 seconds after the quadcopter lands with throttle full down on a level ground.

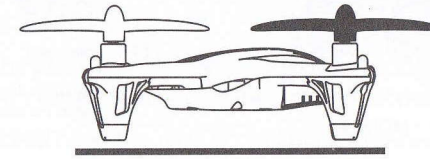

Landing on a level ground

6.2 Transmitter sticks and X4 control responses

CAUTION: To avoid loss of control: ALWAYS move the TX sticks S-L-O-W-L-Y! Be aware that control inputs will reduce available lift. Be ready to use a little extra throttle to maintain height during maneuvers.

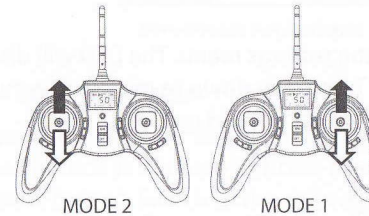

Throttle (Collective Power) increases/decreases the Flying Height of your quadcopter

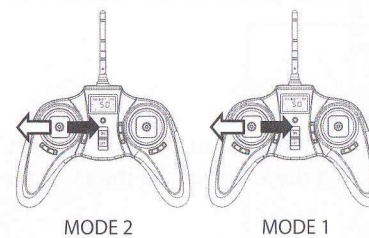

Rudder (Collective Torque Yaw) rotates your quadcopter's fuselage Left / Right

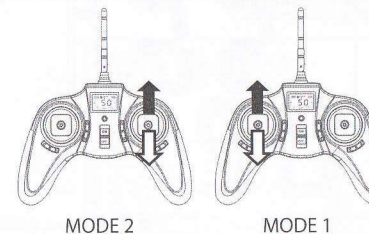

Elevator (Cyclic Pitch) moves your quadcopter Forwards/Backwards

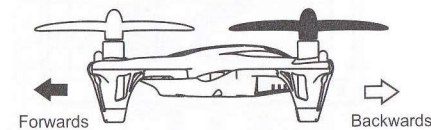

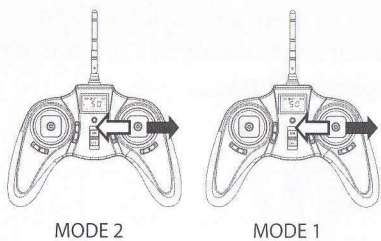

MODE 2

MODE 1

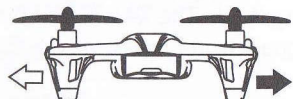

LEFT movement

RIGHT movement

CAUTION: Controls will *appear reversed* when the model is flying towards you!

Aileron (Cyclic Roll) moves your quadcopter 'sideways' Left/Right

7 ADVANCED PERFORMANCE SETUP

7.1 Reversing Channel Setup

7.1.1 ELEV REVERSE SET UP

Hold down the Elevator stick for 1 second to enter the settings menu. The LCD will display "SE" as the picture below shows. Press the Elevator Trim up or down to reverse the channel, and then hold down the Elevator stick for 1 second to confirm and exit.

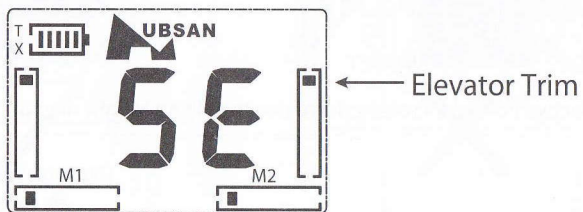

7.1.2 AILE/RUDD REVERSE SET UP

Hold down the Elevator stick for 1 second to enter the setting menu, press (a) Aileron Trim / (b) Rudder Trim left or right to reverse the channel, and then hold down the Elevator stick for 1 second to confirm and exit.

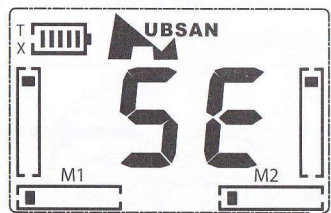

(a)Aileron Trim

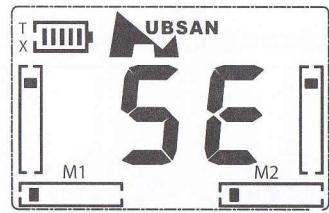

(b)Rudder Trim

7.2 Normal and Expert Flight Modes

The X4 is factory set for Normal Mode flying, and it will always power up in Normal Mode. While fast and responsive in Normal Model, the X4 has even greater performance capability when Expert Mode is activated.

Activate Expert Mode by pressing the Elevator stick (the model and transmitter must both be on). Two "beep", expert mode; one "beep", normal mode.

The LCD will display EXPERT and the red LED will blink to show you are in Expert mode.

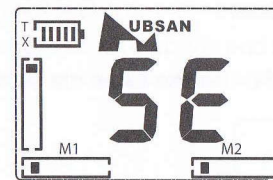

Normal mode (not displayed)

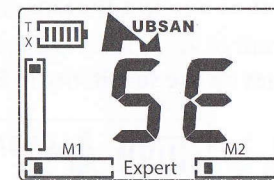

Expert mode displayed

7.3 Sensitivity Setup

Press in the elevator stick for 1 second to enter the setup(SE) menu. Push in the throttle stick at the base until the three-point dotted line symbols start to flash(see picture below). Switch to the different channels by clicking the throttle stick at the base. Press (a)Rudder Trim / (b)Elevator Trim / (c)Aileron Trim to change the sensitivity values showing on the LCD and then hold down the elevator stick for 1 second to confirm or exit. The X4 will be more sensitive and responsive with the higher values.

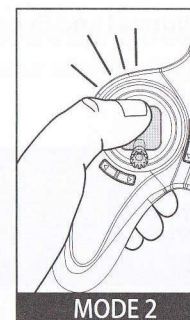

MODE 2

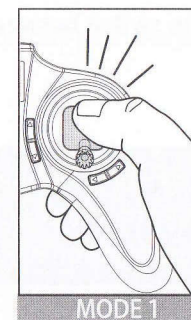

MODE 1

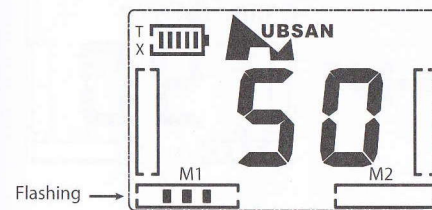

Flashing →

(a)Rudder Sensivity Adjustment

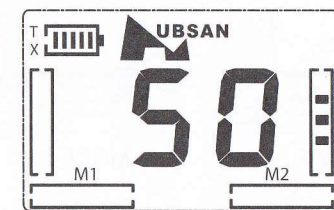

← Flashing

(b)Elevator Sensivity Adjustment

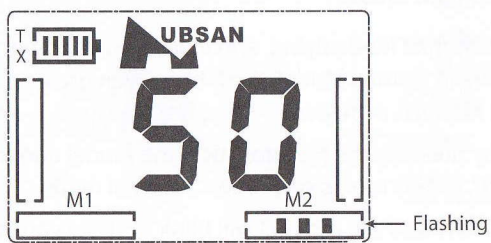

(c) Aileron Sensivity Adjustment

You can also set up the sensitivity in Expert mode. Use the same method above.

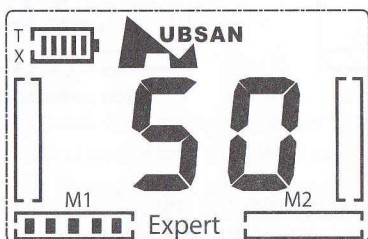

3 dots displayed in Normal (Sensitivity reach 20-60%)

5 dots displayed in Expert (Sensitivity reach 60-100%)

Press the Elevator stick to switch between Normal and Expert mode at any time.

7.4 Aerial Flip Tips.

The flip maneuver will only work in the the EXPERT MODE when anti-flip is not selected. You need to press the elevator stick one time to switch into the expert mode. To select anti-flip momentarily press the throttle stick in: On=one beep. Off=two beeps.

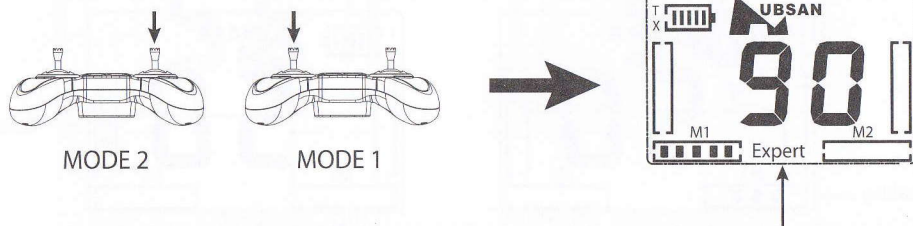

Your X4 can do 360° flips by pushing the joysticks as described below. For proper flip execution, make certain that the X4 is close to level, within a 30° angle with the ground, and add some climb throttle before you move the pitch and roll sticks.

7.5.1 Left side flip

Push the joystick to the right side and then quickly push the joystick to the left and then release the stick to the center position after the flip.

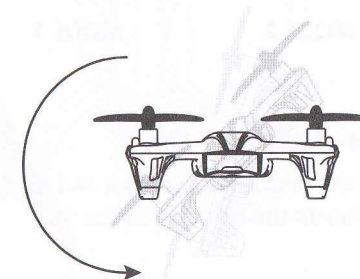
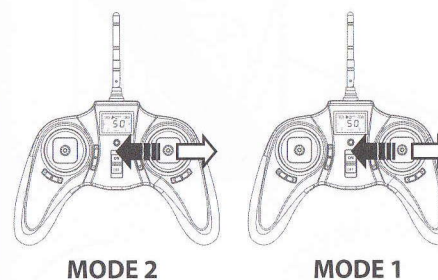

7.5.2 Right side flip

Push the joystick to the full left side and then quickly push the joystick to full right and release the stick to the center after the flip.

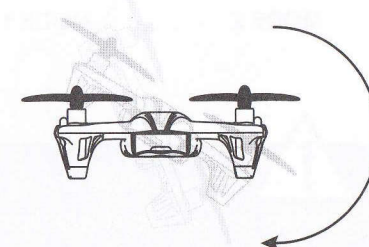
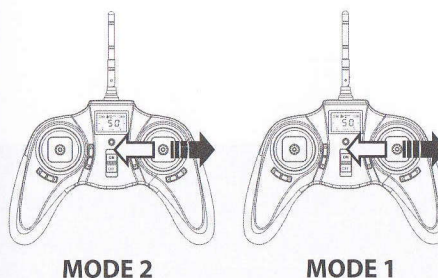

7.5.3 Forward flip

Pull the joystick to the back and then quickly push the joystick to the front and release the stick to the center after the flip.

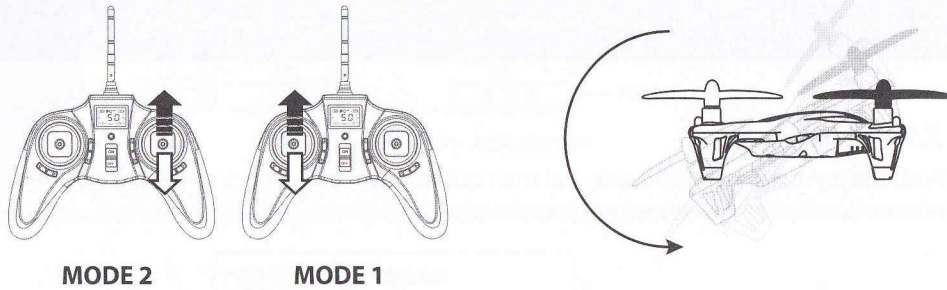

7.6.4 Backward flip

Push the joystick to the front and then quickly pull the joystick to the back and release the stick to the center after the flip.

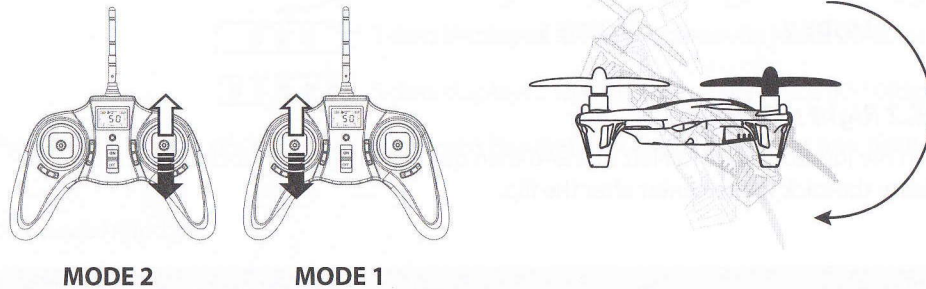

In Expert Mode, the X4 can fly at high speeds and do flips. If you don't need it to flip, you can select anti-flip mode. Press the throttle stick to select or deselect anti-flip. ON=one TX beep=it can't flip. OFF=two TX beeps=It can do flips. Note that when the X4 runs out of lipo power, it also can't flip.

8 PROPELLER INSTALLATION AND REMOVAL

The X4's props are not identical. Each prop is labeled with an A or B. When installing replacement props, be certain to install them as shown. The X4 will not fly, and will flip and crash if the props are not installed in their proper locations.

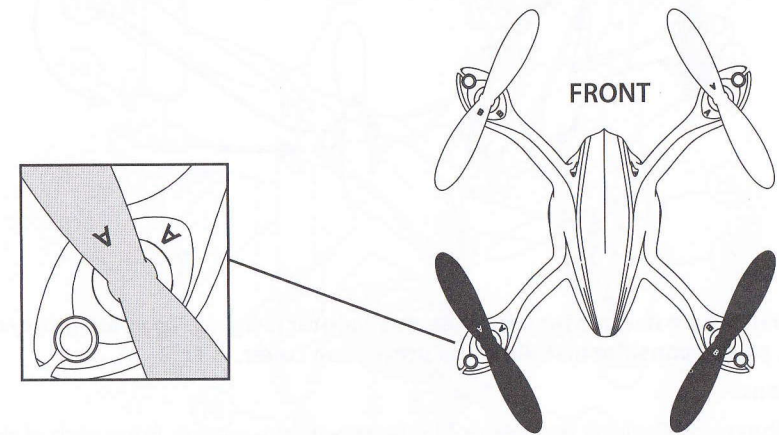

Installation: Pinch the prop hub, line up the hole to the motor shaft, press it firmly but gently straight down.

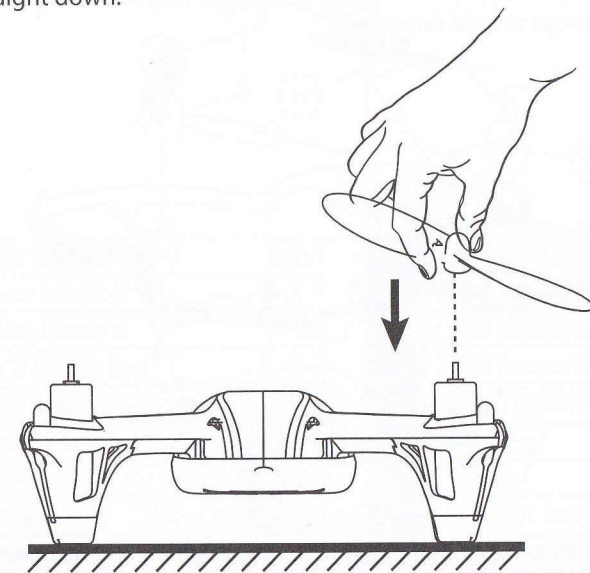

Removing Props: Hold the prop, insert the U wrench under the prop, press down and the prop will easily come off the motor shaft.

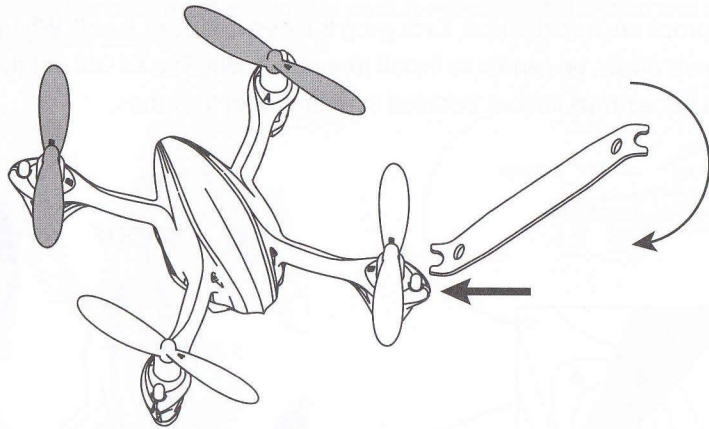

The propellers are dangerous when the quadcopter is flying. To avoid injury or damage, please consider installing the protection cover.

Instructions:

Remove the props. Position the cover's four holes with the motors. Press each of them on the motors, then re-install the props in their correct positions on the X4.

When removing the protection cover, please remove the props first as in the above steps, and pinch off the protection cover from each motor. After any crash landing, please check to make sure the protection cover is still on tight, and make sure the body, motors and props are not damaged.

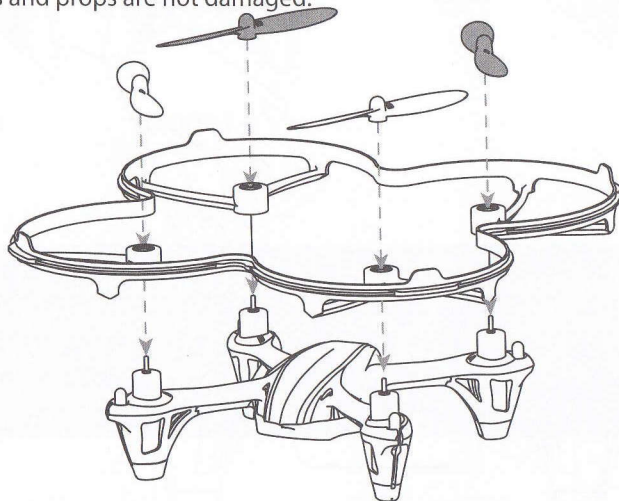

* The above U-wrench and protection cover are not included and must be ordered.

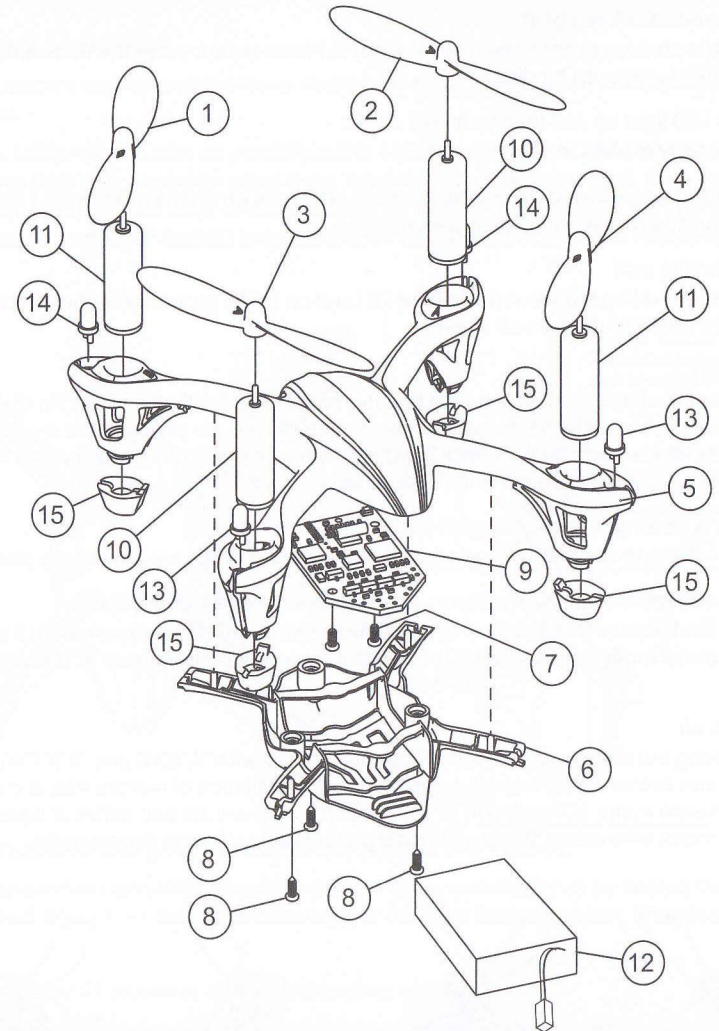

No	PART NAME	QTY	No	PART NAME	QTY
1	White blade B	1	9	RX	1
2	White blade A	1	10	720 motor(clockwise)	2
3	Black blade A	1	11	720 motor(anticlockwise)	2
4	Blackblade B	1	12	Li-po battery	1
5	Upper shell	1	13	LED-2	2
6	Lower shell	1	14	LED-1	2
7	Screw	2	15	Rubber feet	4
8	Screw	3			

1. Transmitter and X4 will not bind.

Answer: Throttle position needs to be fully minimized. Please do not move the transmitter sticks or trims during initial power-on binding.

2. Transmitter LED light on and then suddenly off.

Answer: Replace new AAA batteries

3. LCD transmitter not showing the setting interface after hold down the joystick for 1 second.

Answer: The throttle stick is not in the lowest position.

4. Gyro not working well

Answer: (1) Battery voltage too low. (2) Re-bind (3) Land on to the ground with the throttle fully minimized for 3 seconds and take off again.

5. Unable to Flip

Answer: (1) Press the Elevator stick one time to enter into the expert(flip) mode. (2) In the expert(flip) mode, the sensitivity on each channel should be above 90%, you can program the sensitivity in the setup menu. Please check manual 4.4 Stick Sensitivity Adjustment. (3) Press the throttle stick to turn off anti-flip. (4) Lipo power is too low and needs to be recharged.

6. Quadcopter is shaking or oscillating with noise.

Answer: Please check to see that the motors, canopy, body and props are all properly positioned.

7. Switching between low and high rates on the transmitter not very user-friendly.

Answer: Press the Elevator stick briefly only one time to switch on/off the expert mode(red flashing TX LED) and normal mode(green solid LED). The word "Expert" will also appear at the bottom center on the LCD.

8. Can not take off.

Answer: (1) Wrong installation of the props. Props are marked with "A"(CW) and "B"(CCW). Please check the pictures below for the correct order. (2) Wrong installation of motors. Please check to make sure that each motor is installed in its correct position. There are two different types of motors with different motor wire colors. Please check the pictures below for the correct order.

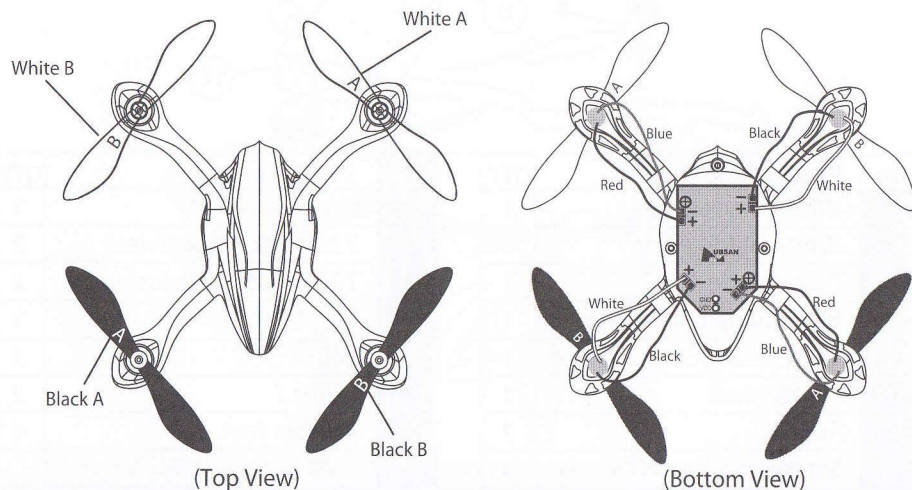

9. LED removal & installation.

Removal: Unscrew and remove the lower shell and the rubber feet. Then unsolder the red and yellow wires.

Installation: Solder the red wire on anode/positive (+), the yellow on cathode/negative (-), press the LED wires first, then the motor wires in the leg slots. Install the lower shell, then the rubber feet. You can determine the color of the LED lights by looking at the color of the LED wire insulation at the bottom of the LED lens: white color is white light, blue color is blue light.

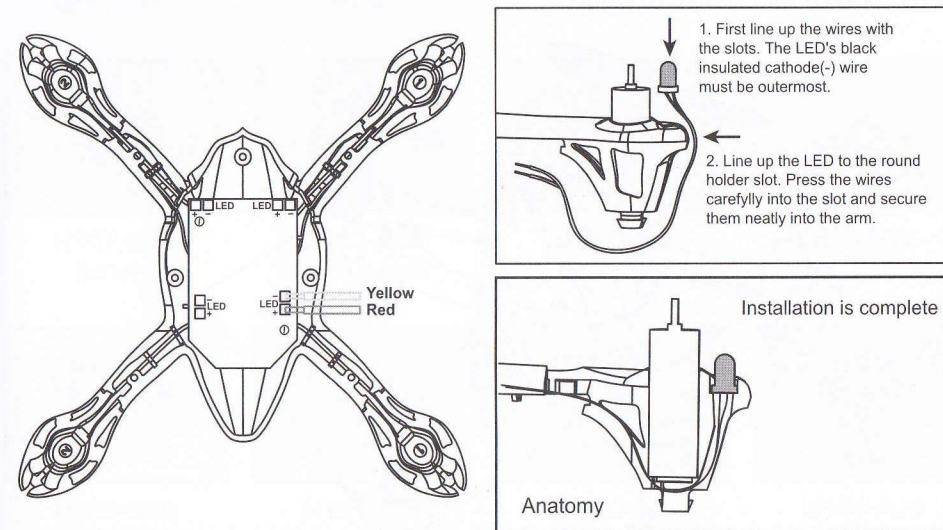

10. The motors are a little gritty and do not spin as freely after crashes.

Answer: You can hear grinding and see that motor is not spinning freely by flicking the prop. Press the shaft down from the top of the prop and motor to fix the problem, or replace the motor.

11. The arm of the X4 separates after a hard landing or crash.

Answer: This is a special design to absorb the impact from hard crashes. Simply force the arms to snap back into the joint position by hand as shown in the picture.

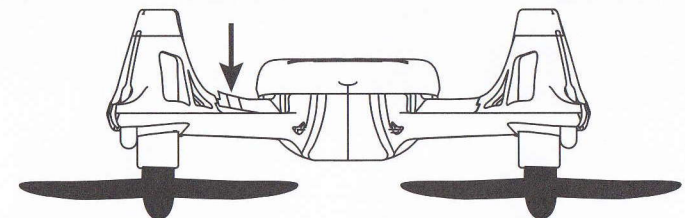

12. One or more motors stop working

Answer: (1) Motor is damaged. Replace the motor.

(2) The motor connections(s) are disconnected. Resolder.

(3) An FET on the flight controller looks burned. Replace the flight controller.

13. The X4 is still drifting excessively when hovering even after a good accelerometer calibration.

Answer: Set it on a level surface and shim the side that it drifts to with a few sheets of paper (the number of sheets will vary depending on the amount of drift), so it can calibrate the accelerometers with a level offset angle.

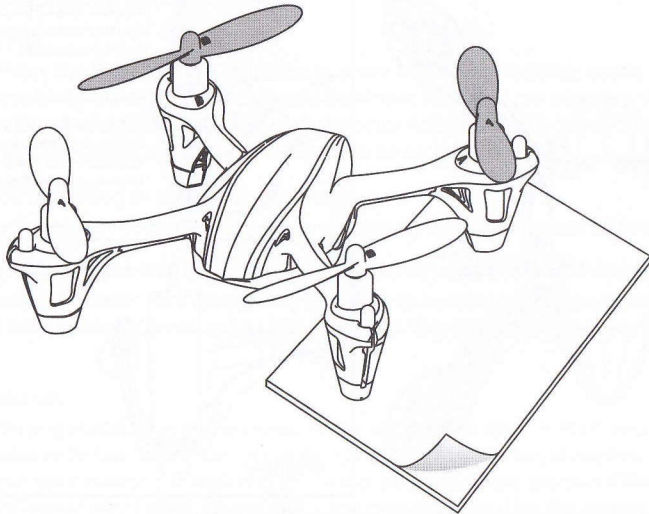

H107 SPARE PART CHART

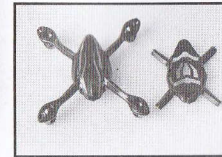

H107-A31
Body Shell

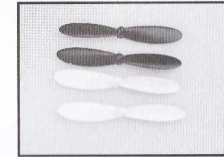

H107-A02
Props

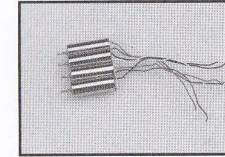

H107-A03
Motor

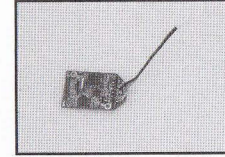

H107-A34
X4 RX

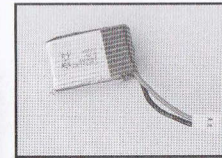

H107-A05
Battery

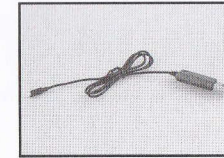

H107-A06
USB Charger

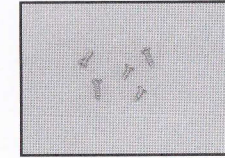

H107-A07
Screw Set



H107-16
Transmitter



H107-A39
Rubber feet

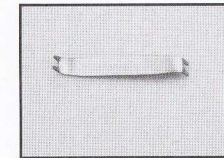

H107-A11
U wrench

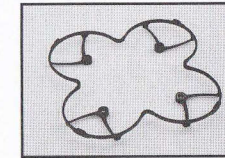

H107-12
Protection Cover



H107-A13
T-Shirt

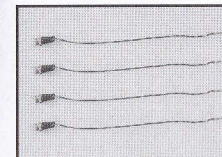

H107-A32
Blue LED

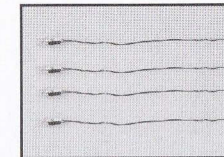

H107-A33
White LED

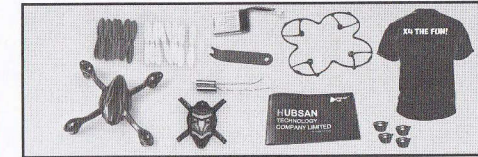

H107-A18
Value pack