

GENESIS II

E-210™ • E-310™ • E-410™ • SE-410™ • E-610™



ASSEMBLY GUIDE

GUÍA DE MONTAJE | ENSEMBLE GUIDE

Before you begin



Enhance your assembly experience.

Download the free BILT™ app for
3D step-by-step instructions.



Descarga gratis la app BILT™ y sigue las instrucciones 3D paso a paso.

Téléchargez gratuitement l'application BILT™ pour obtenir les instructions étape par étape en 3D.

68051

091516
US / ES / FR



FOR LIFE

EN

- ⚠ Assemble grill on a flat, level, and soft surface.
 - ⚠ Remove protective film from stainless steel parts before installing.
 - ⚠ Do not use power tools for assembly.
 - ⚠ 2 people required for assembly.
 - ⚠ There may be visual differences between illustrations and model purchased.
-

ES





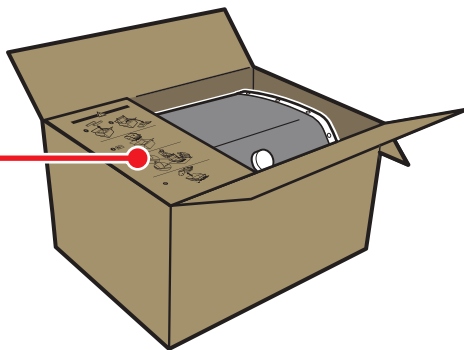
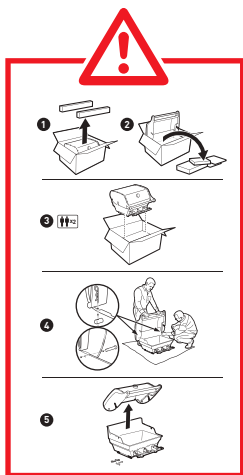

- ⚠ Monte el asador sobre una superficie llana, nivelada y lisa.
 - ⚠ Retire la película protectora de las piezas de acero inoxidable antes de llevar a cabo la instalación.
 - ⚠ No use herramientas eléctricas para montar el asador.
 - ⚠ Se requieren dos personas para montar el asador.
 - ⚠ Puede que existan diferencias visuales entre las ilustraciones y el modelo adquirido.
-

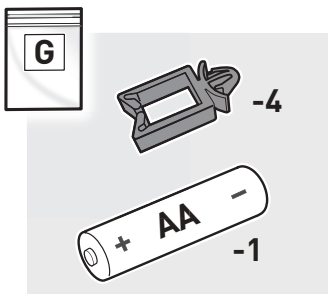
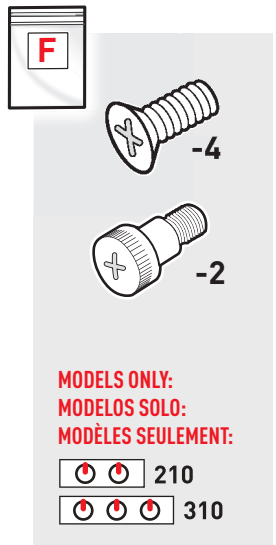
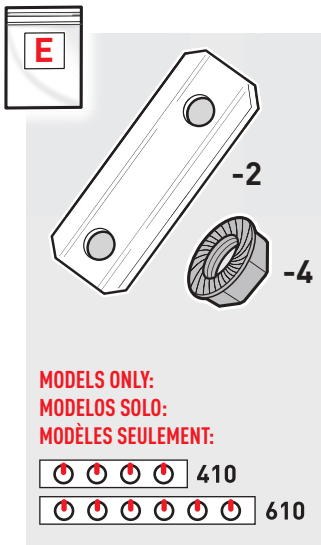
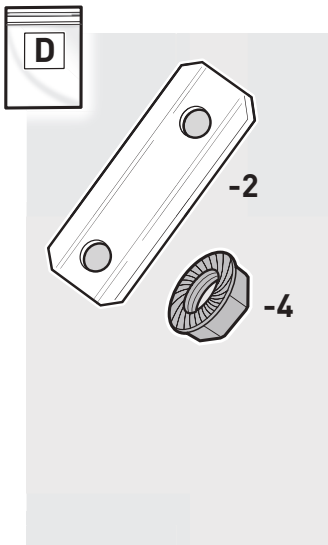
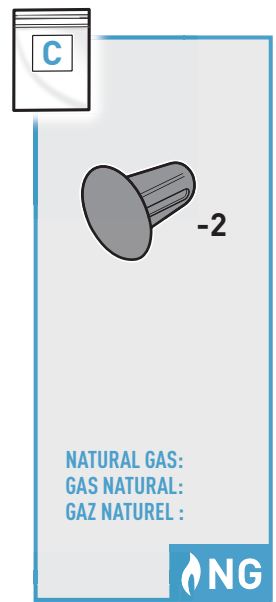
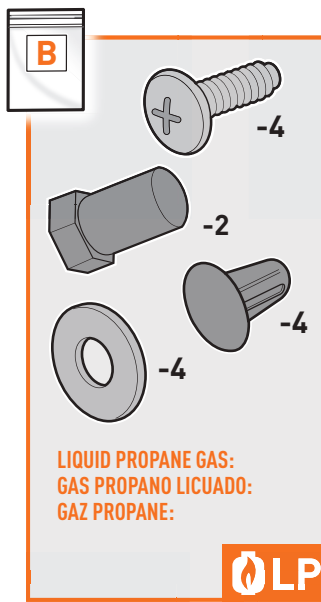
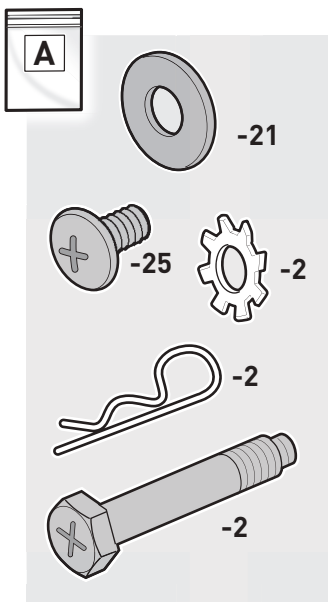

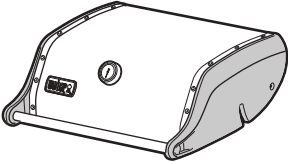
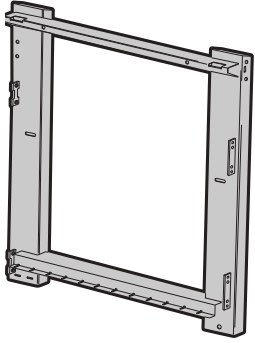
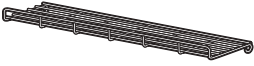
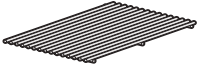

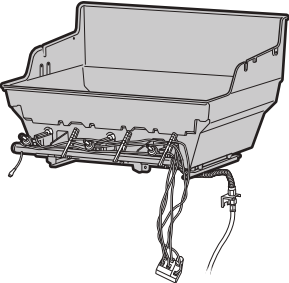
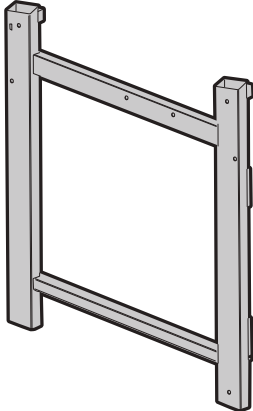
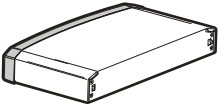

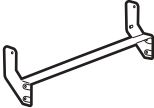
FR

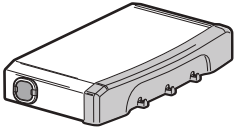
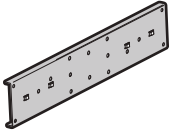
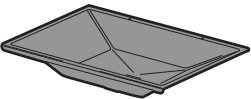
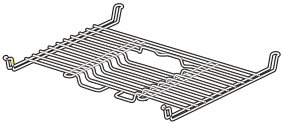
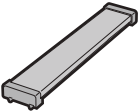

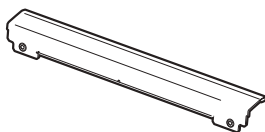
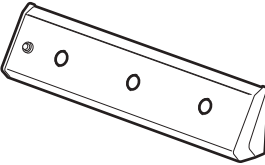
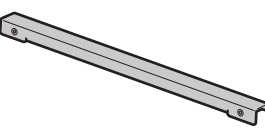
- ⚠ Assemblez le barbecue sur une surface plate, de niveau et souple.
- ⚠ Avant de procéder à l'assemblage, retirez le film protecteur qui recouvre les pièces en acier inoxydable.
- ⚠ N'utilisez pas d'outil électrique pour assembler le barbecue.
- ⚠ Il faut deux personnes pour assembler le barbecue.
- ⚠ Le modèle de barbecue que vous avez acheté peut différer des illustrations.



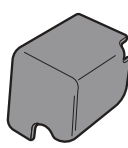



210	310	410	610		210	310	410	610	
1	1	1	1		1	1	1	1	
1	1	1	2		1	1	1	1	
2	2	3	3						
3	5	7	11						
2	3	4	6						
1	1	1	1		1	1	1	1	
1	1	1	1		1	1	1	1	
1	1	0	0		2	2	2	2	
1	1	1	1		2	2	2	2	
1	1	1	1		1	1	1	1	
1	1	1	1		6	8	10	12	

210	310	410	610	
1	1	1	1	
1	1	1	1	
1	1	1	1	
1	1	1	1	
1	1	1	1	
2	3	4	6	
1	1	1	1	
1	1	1	1	
2	2	2	2	

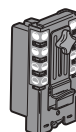
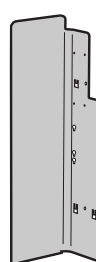
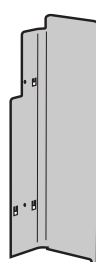
210	310	410	610	
2	2	2	2	
2	2	2	2	

LP				
1	1	1	1	
1	1	1	1	
1	1	1	1	

NG				
1	1	1	1	

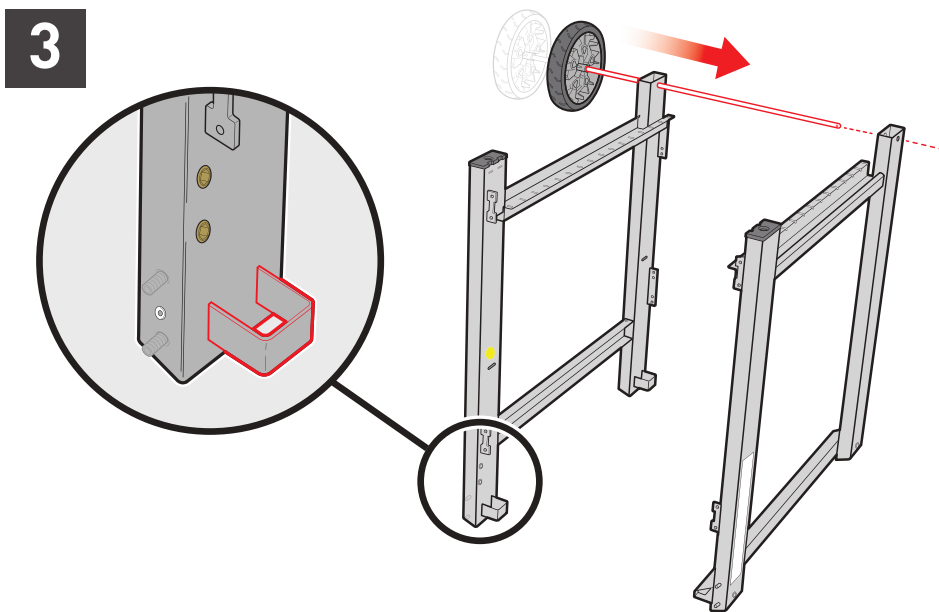
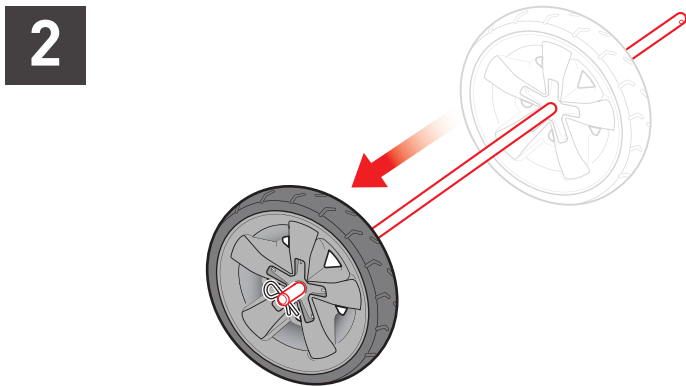
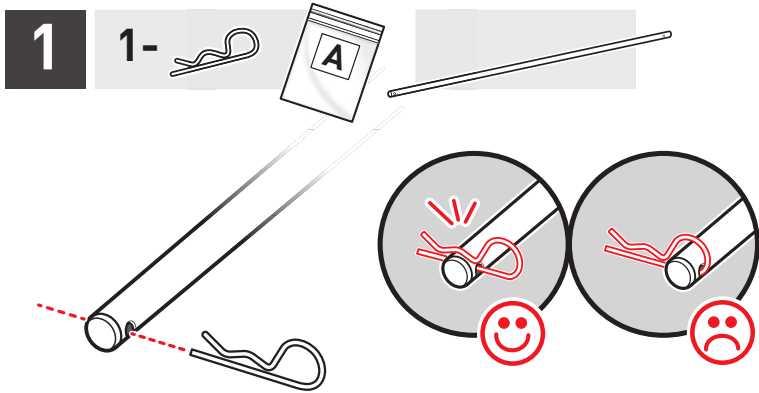

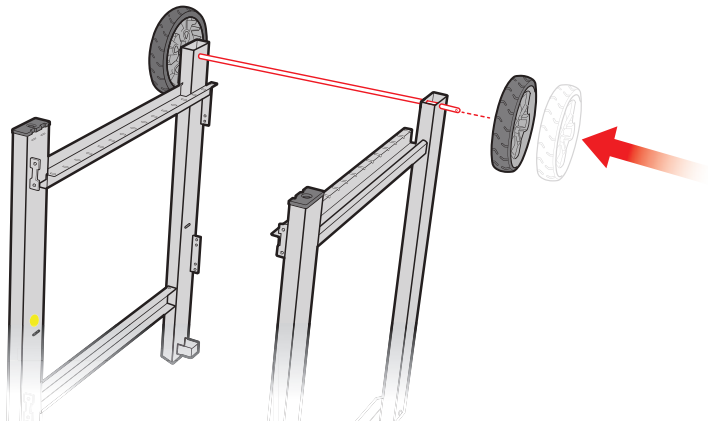
4**5**

1-

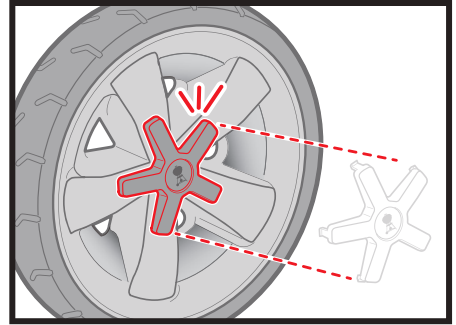
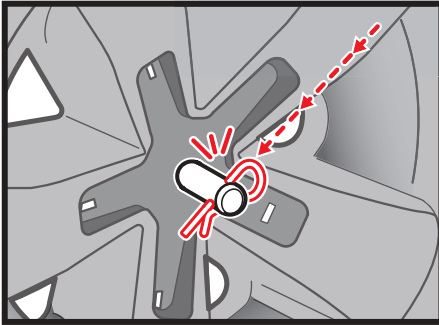
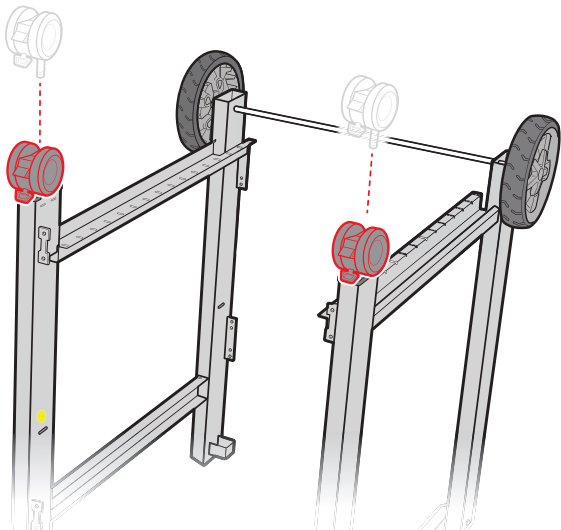
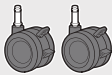
**6**

7

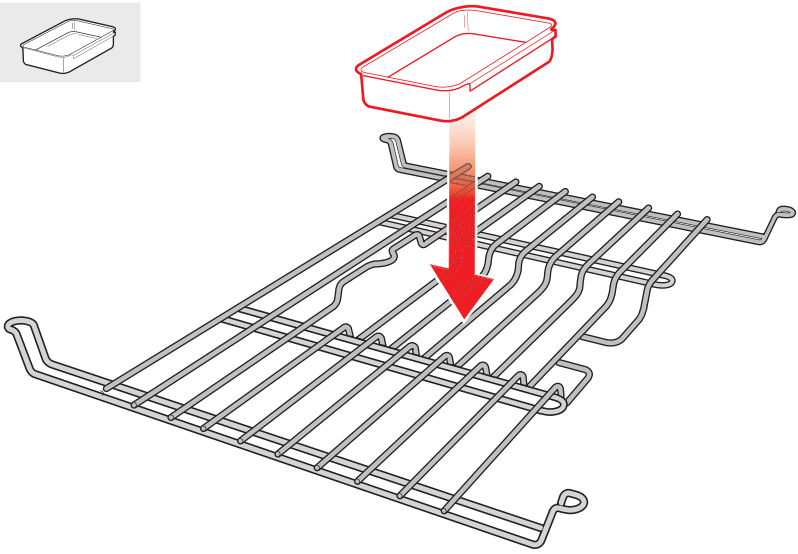
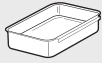

8

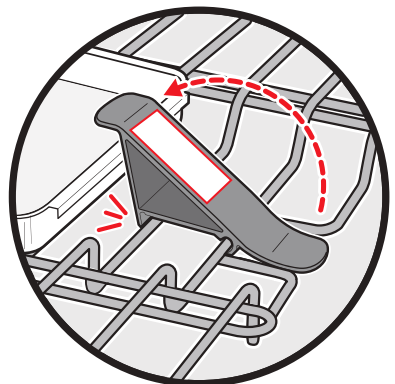
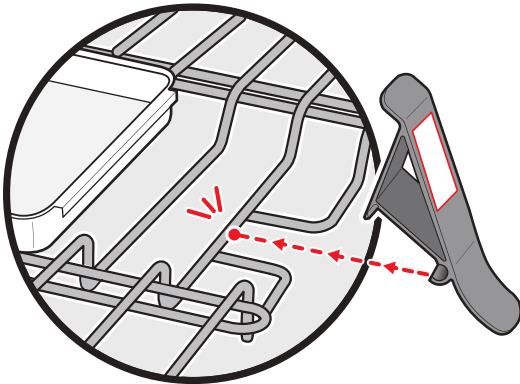
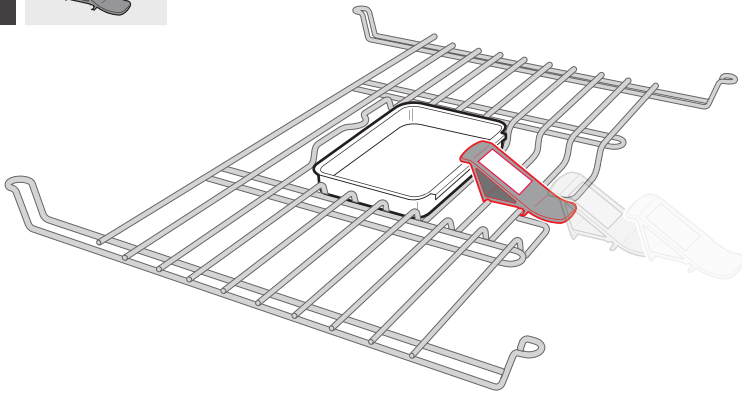

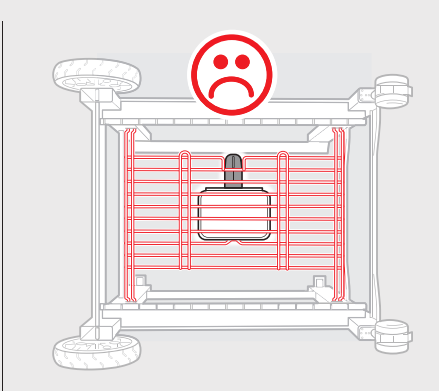
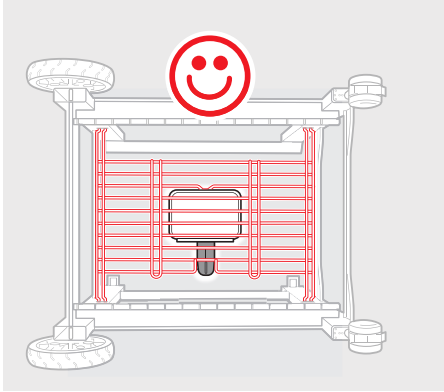
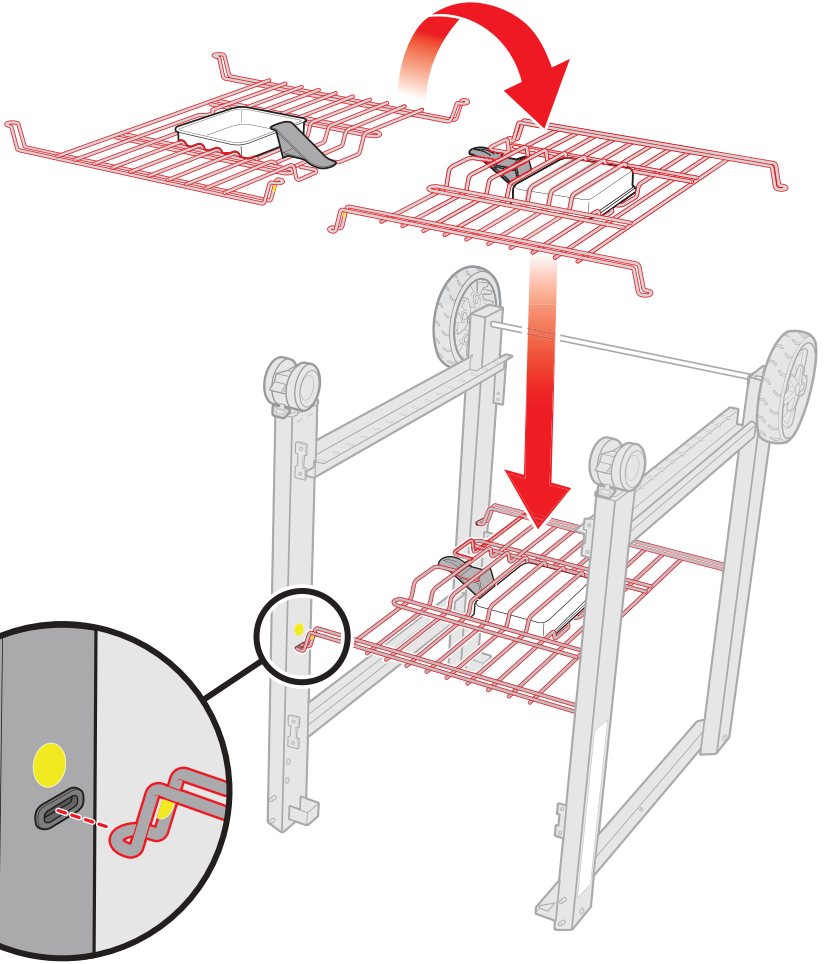

10

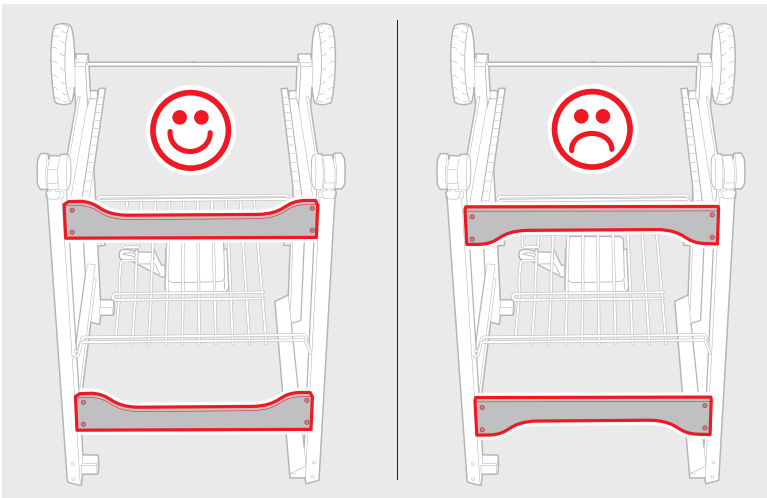
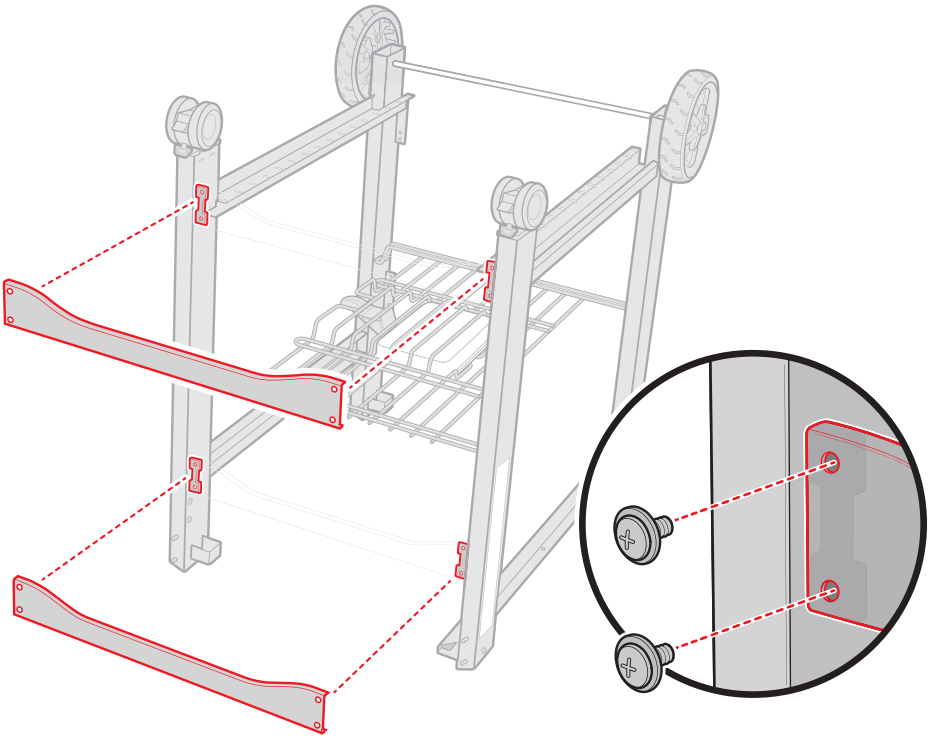

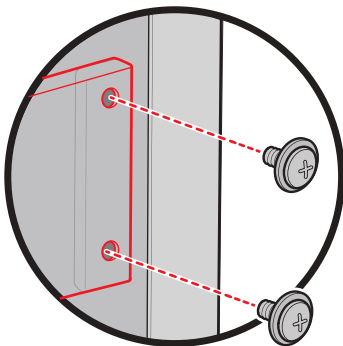
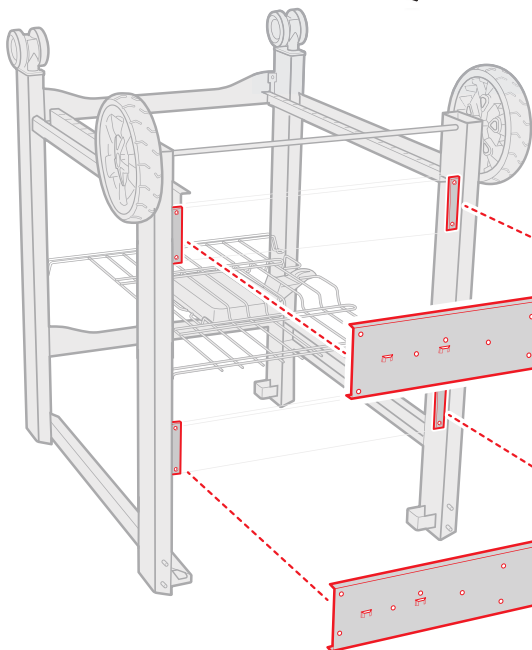
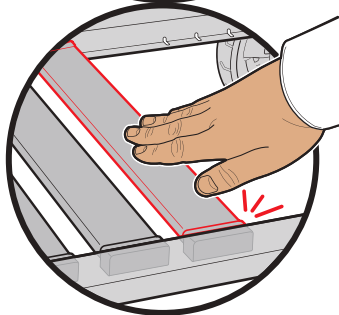
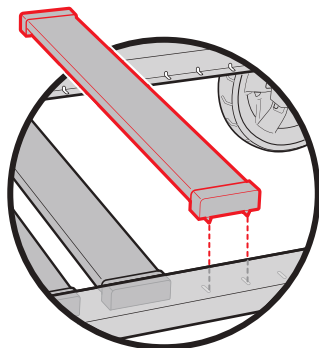
118- 8- **12**

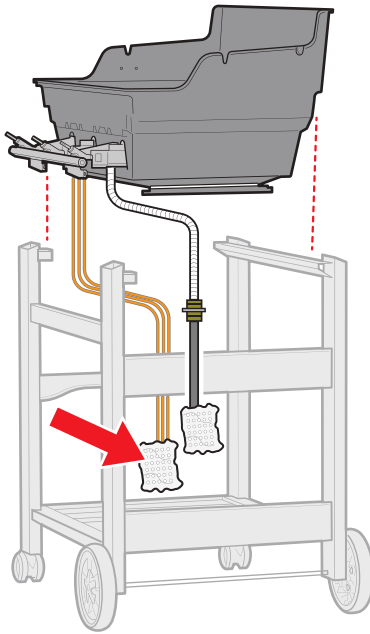

- ⚠ Remove all packing material.
- ⚠ Retirar todo el material de embalaje.
- ⚠ Retirer l'emballage.

⚠ IMPORTANT!

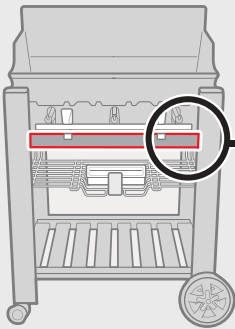

⚠ ¡IMPORTANTE!

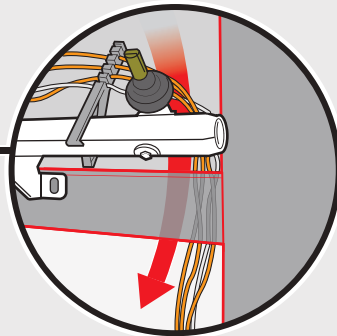

⚠ IMPORTANT!

- ⚠ Wires must be routed on the INSIDE of the grill frame.
- ⚠ Los cables deben pasar POR DENTRO del armazón del asador.
- ⚠ Les fils doivent être acheminés à L'INTÉRIEUR du châssis du barbecue.

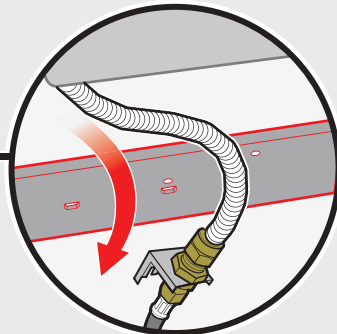
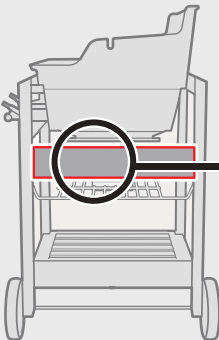

- ⚠ Gas line must be routed on the OUTSIDE of the grill frame.
- ⚠ El tubo de gas debe pasar POR FUERA del armazón del asador.
- ⚠ La conduite de gaz doit être acheminée à L'EXTÉRIEUR du châssis du barbecue.

13

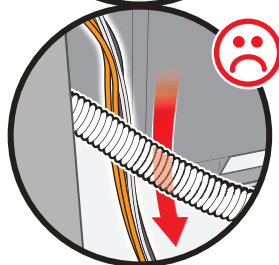
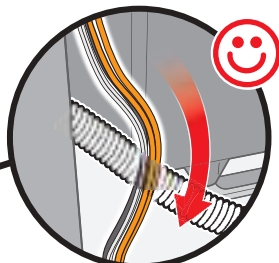
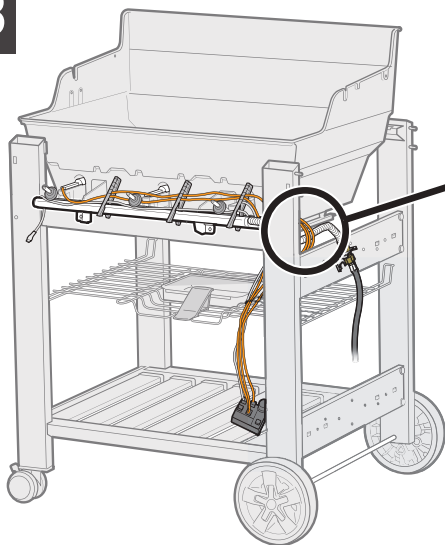

14

2- 

2- 

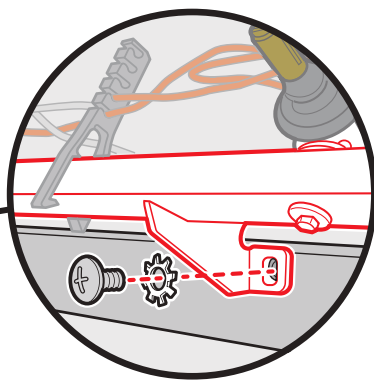
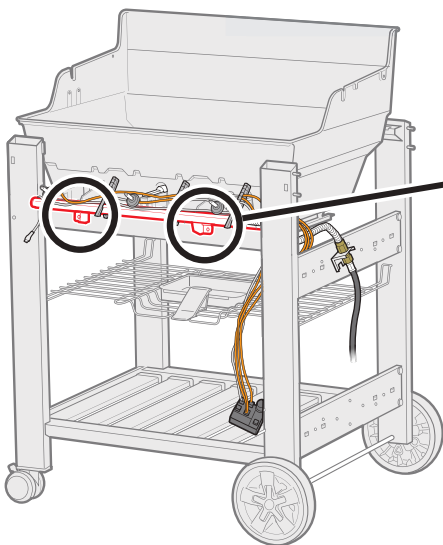

15

2-

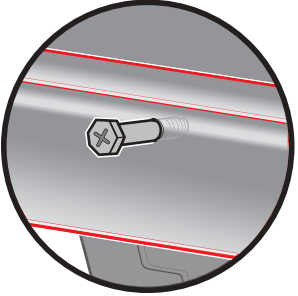
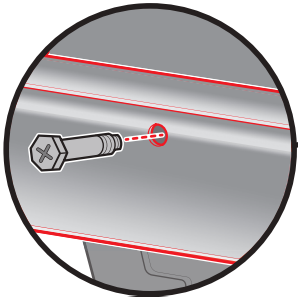
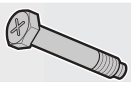

16

2-

2-

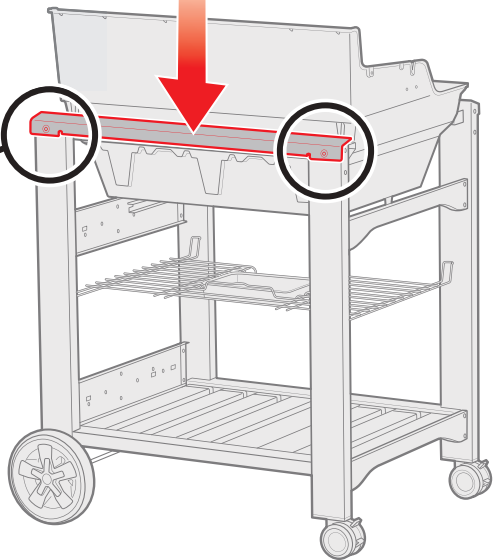
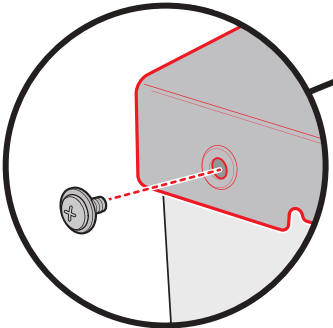

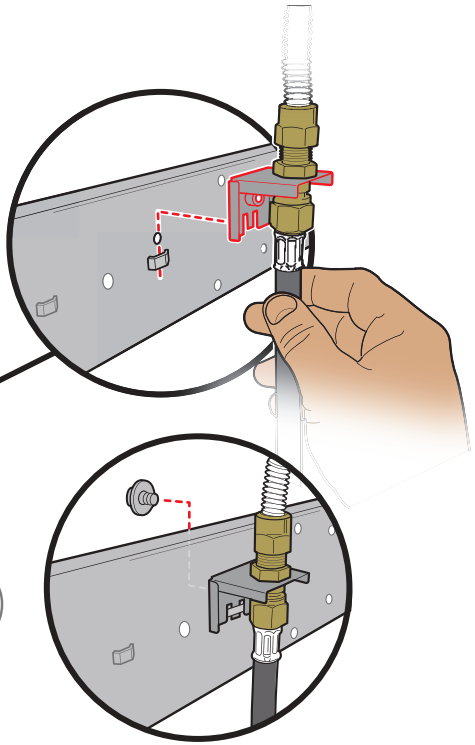
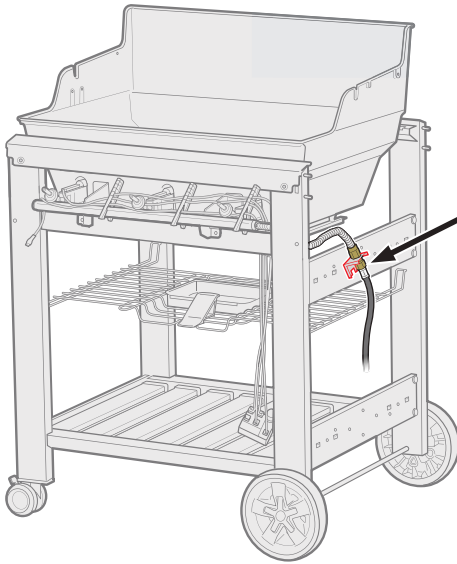
171- 1- **A****18**

LIQUID PROPANE GAS:
 GAS PROPANO LICUADO:
 GAZ PROPANE:

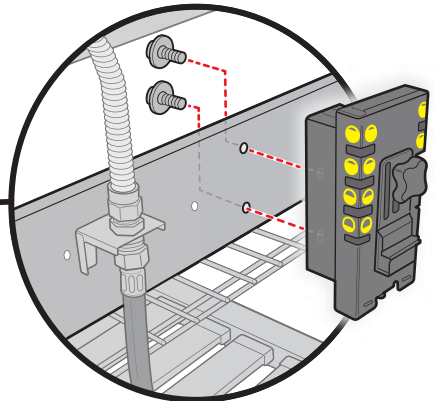
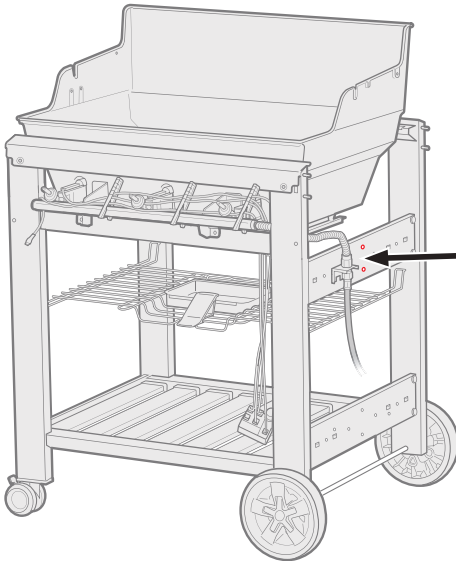
2- 2- **B**

19



LIQUID PROPANE GAS:
GAS PROPANO LICUADO:
GAZ PROPANE:

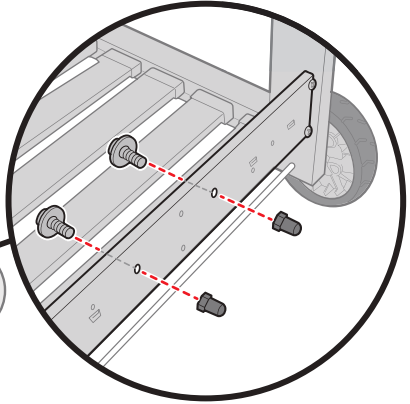
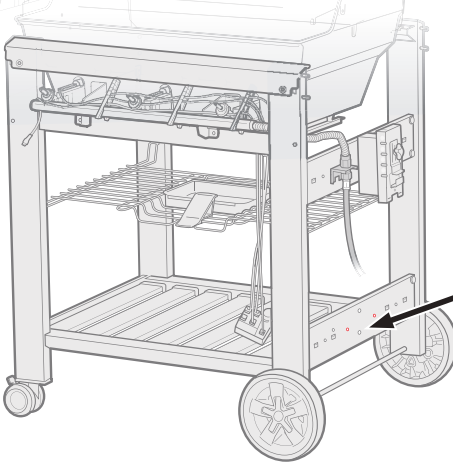

20

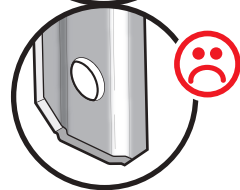
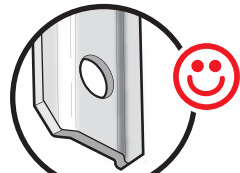
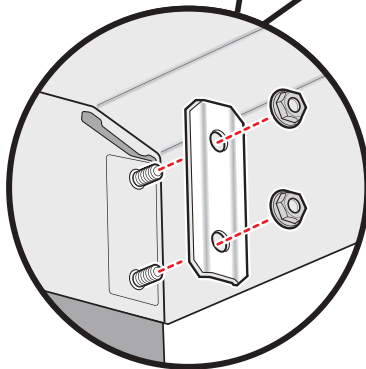
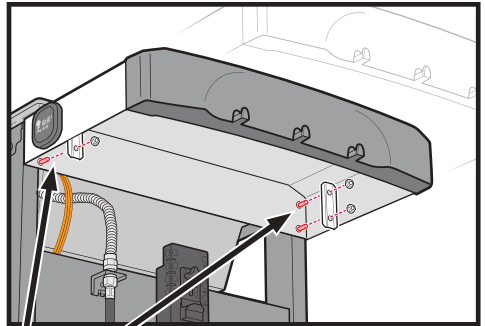
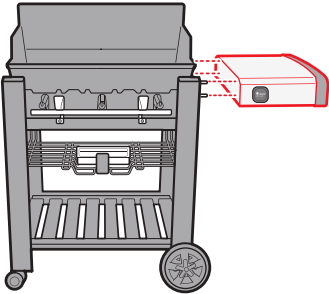

21

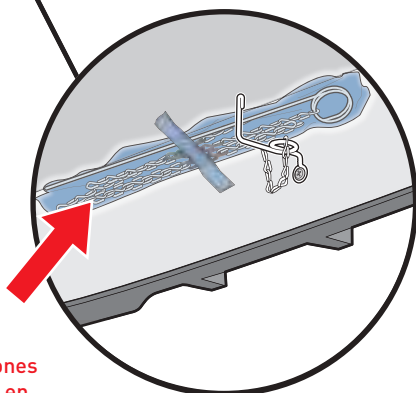
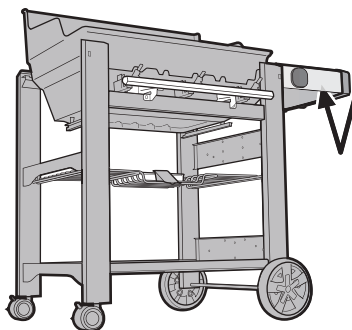

- ⚠ DO NOT REMOVE BAG. See Owner's Manual for complete gas instructions.
- ⚠ NO RETIRE LA BOLSA. Consulte las instrucciones relativas a la manipulación de equipos de gas en el Manual del propietario.
- ⚠ NE PAS RETIRER LE SAC. Voir le Manuel du Propriétaire pour toutes les instructions pour le gaz.

22A

4-

2-

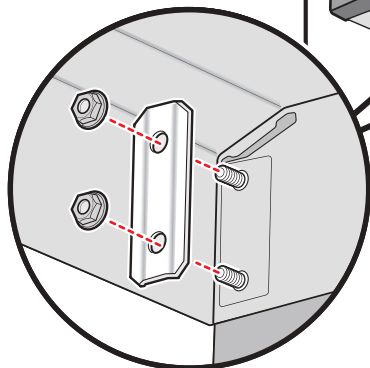
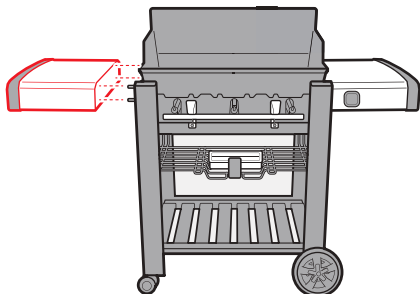
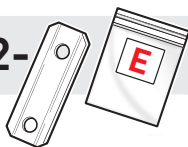

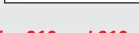
MODELS ONLY:  410
MODELOS SOLO: 
MODÈLES SEULEMENT:  610

- See next page for 210 and 310 models.
- Para modelos 210 y 310, consultar la página siguiente.
- Voir page suivante pour les modèles 210 et 310.

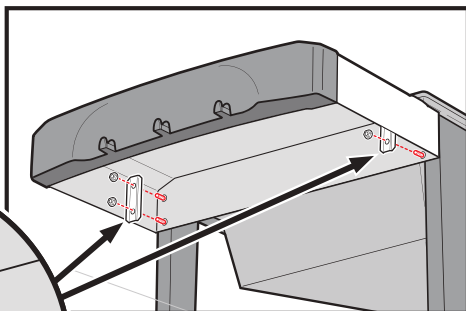

22B

4-



2-



MODELS ONLY:   210
MODELOS SOLO:    310
MODÈLES SEULEMENT:    310

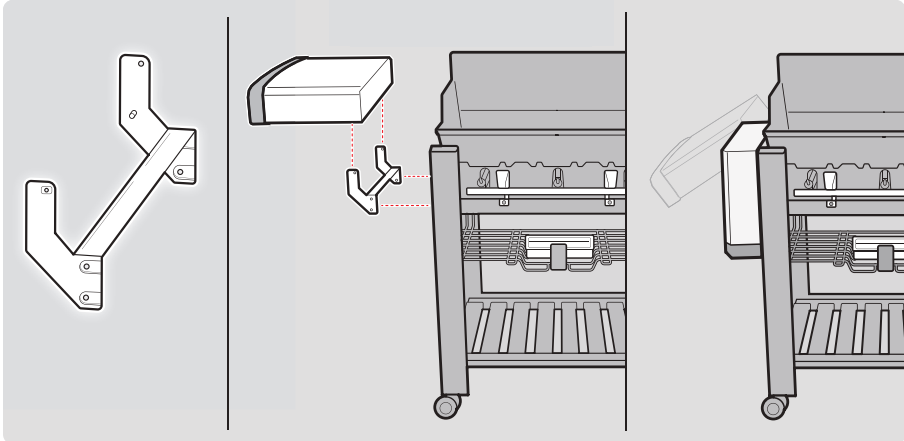

a.

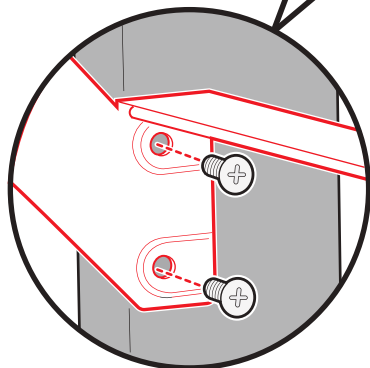
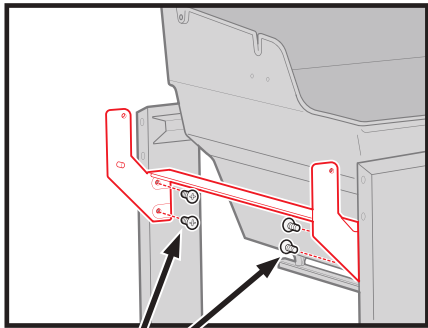
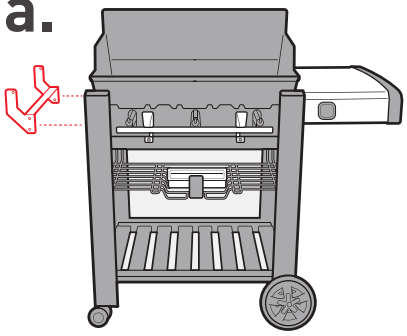

b.

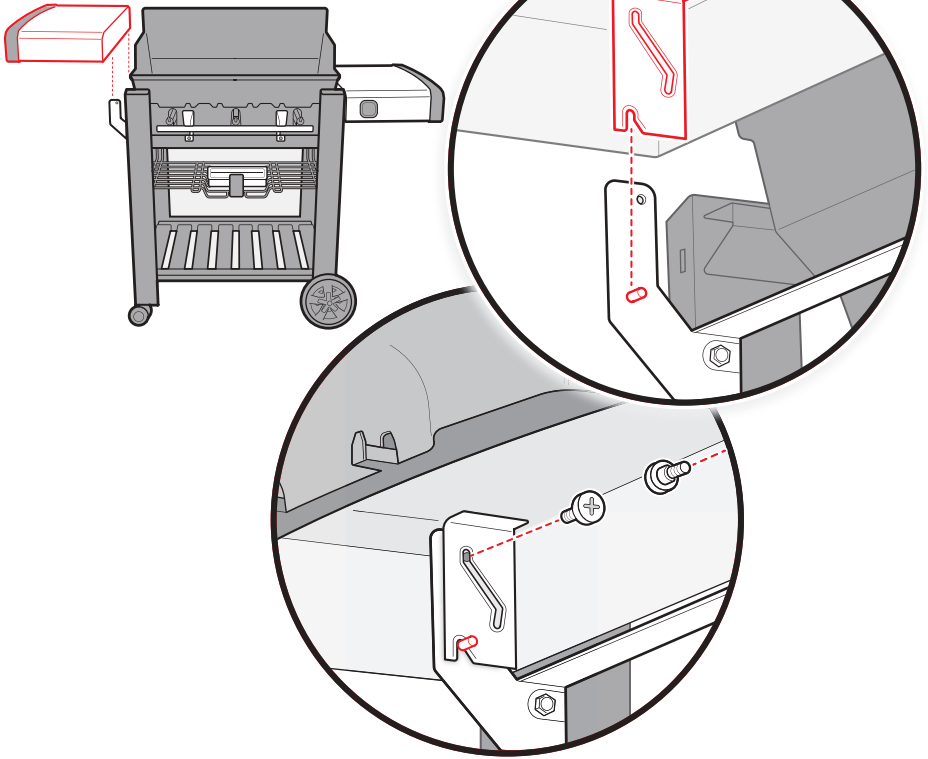

c.

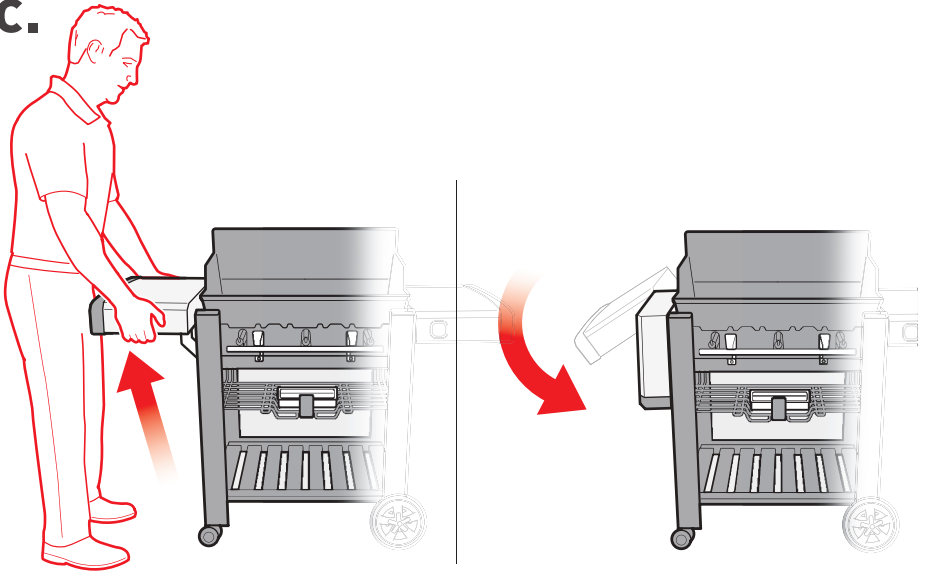

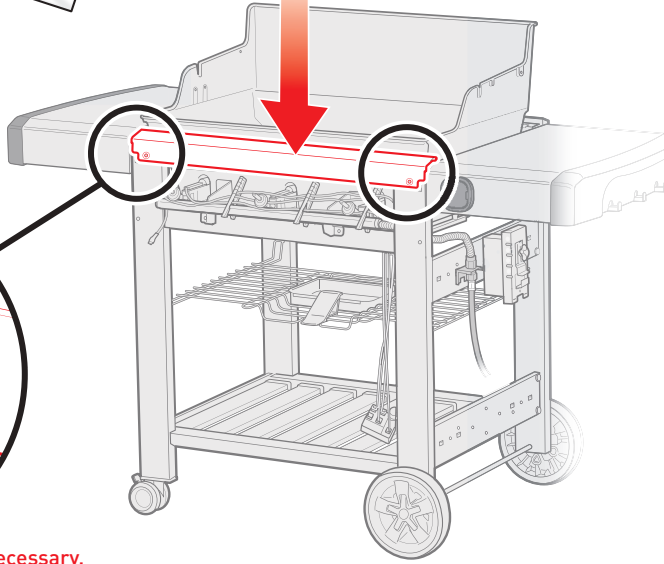
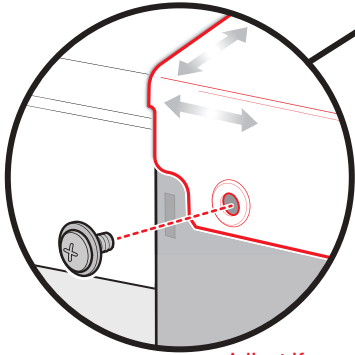
232-  2- 

Adjust if necessary.
 Ajustar si es necesario.
 Ajuster si nécessaire.

24

LIQUID PROPANE GAS:
 GAS PROPANO LICUADO:
 GAZ PROPANE:

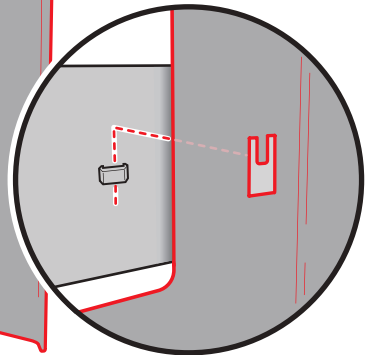
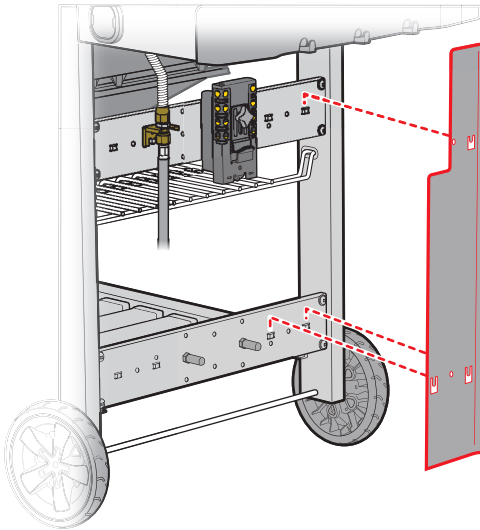
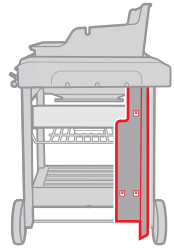
2- 

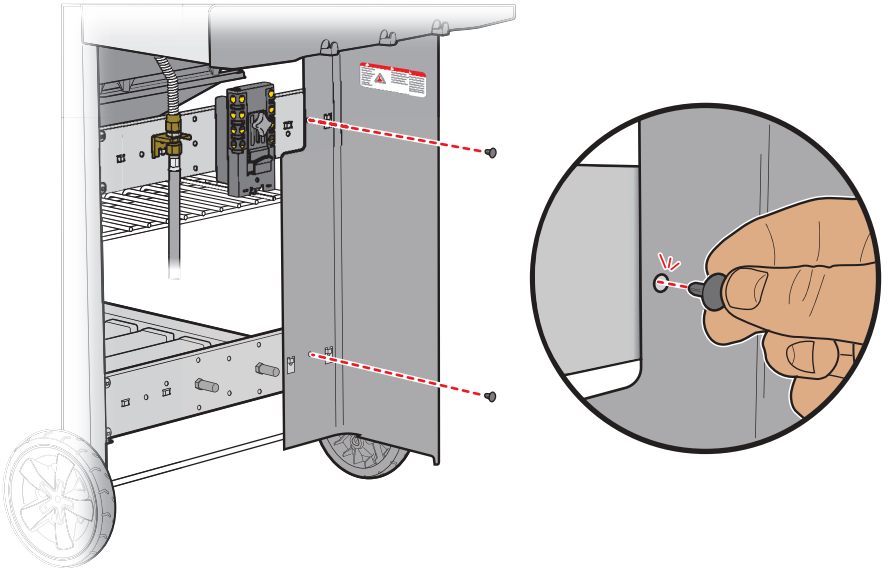

25A



LIQUID PROPANE GAS:
GAS PROPANO LICUADO:
GAZ PROPANE:

2-

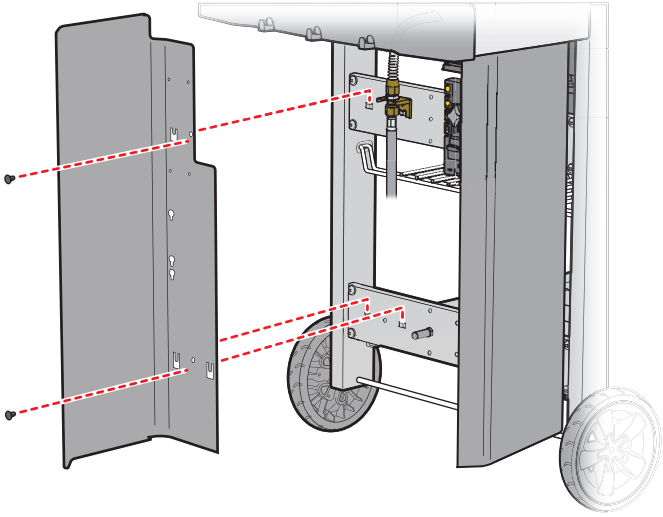

25B



NATURAL GAS:
GAS NATURAL:
GAZ NATUREL :

2-

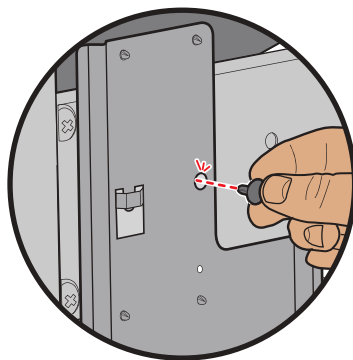
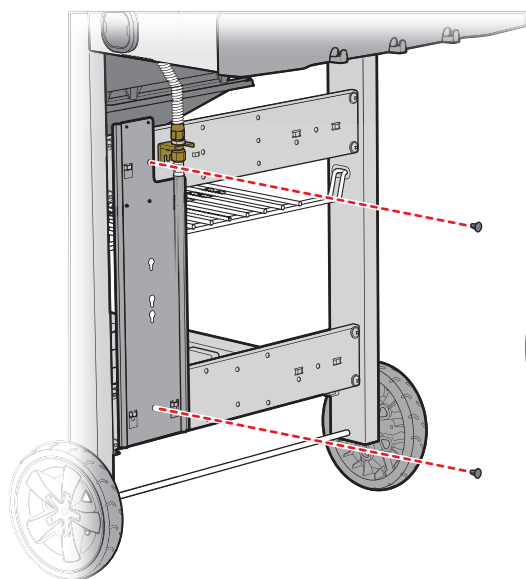
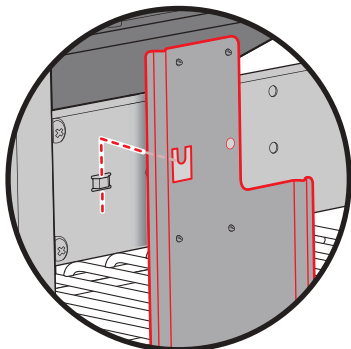
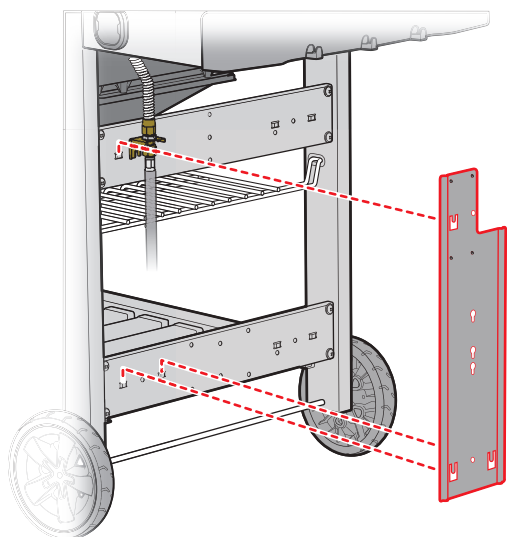
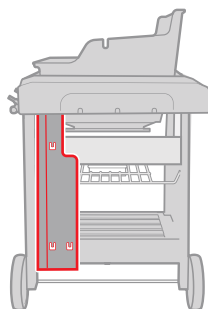

26

4-

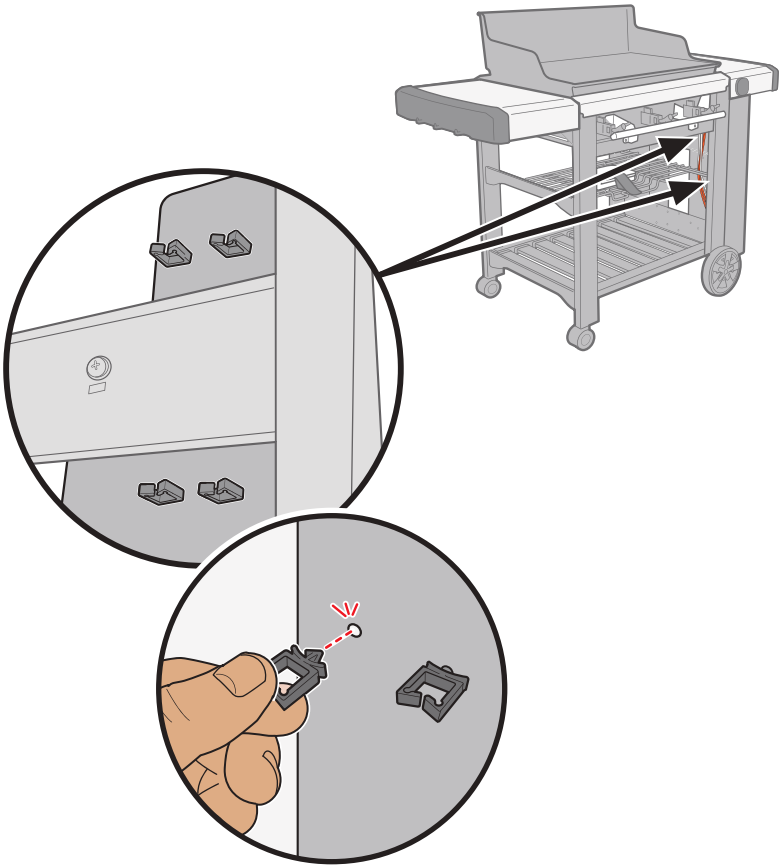

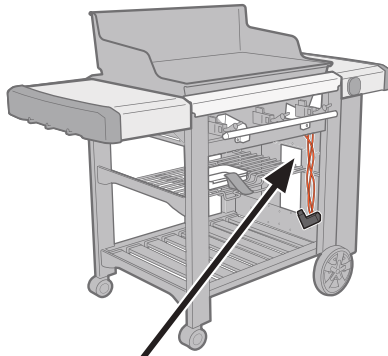

a.

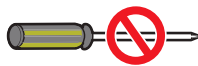
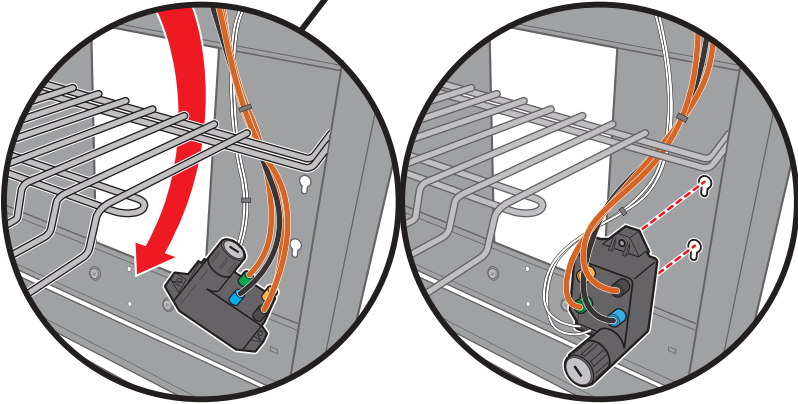

- ⚠ Do not tighten screws at this time.
- ⚠ No apretar los tornillos todavía.
- ⚠ Ne pas encore serrer les vis.

b.

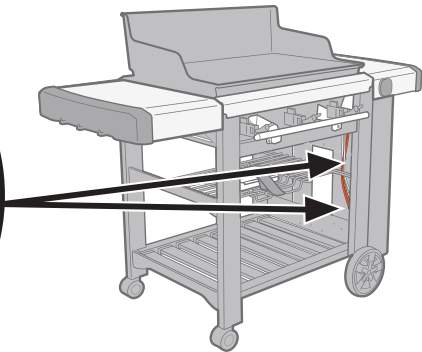
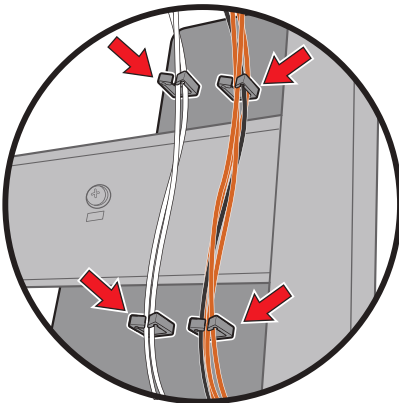

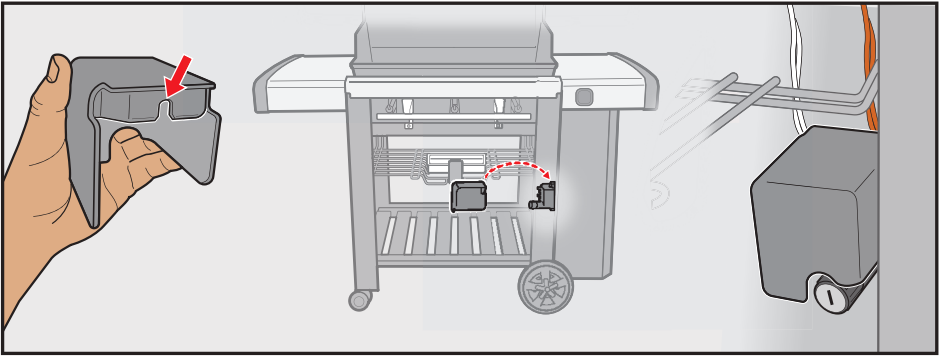

c.

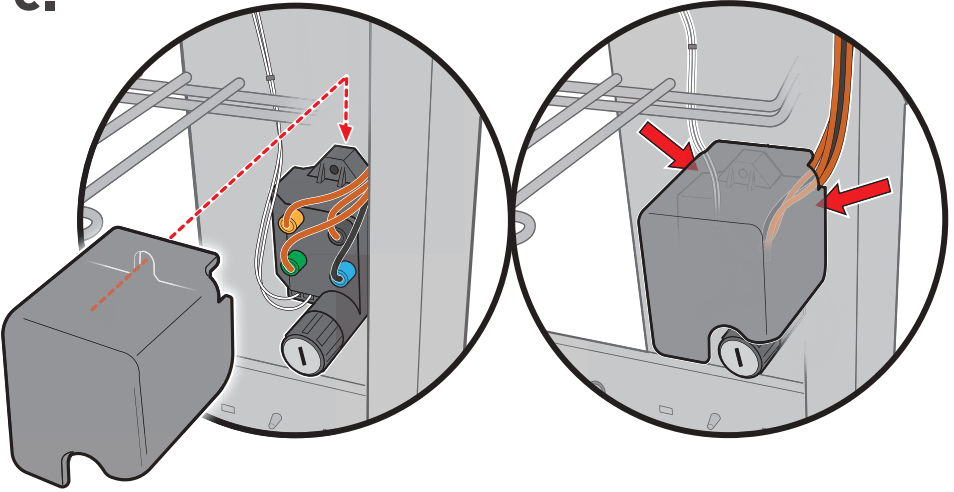

d.

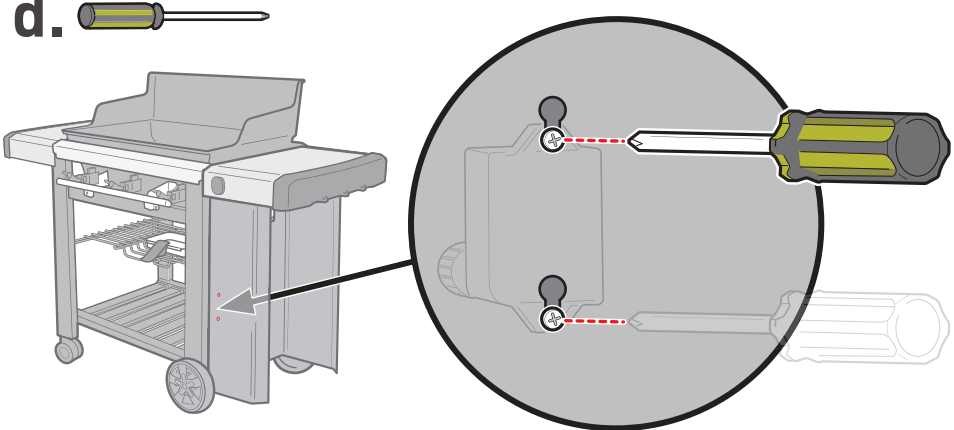

28

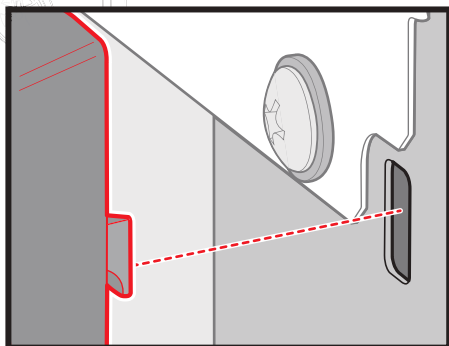
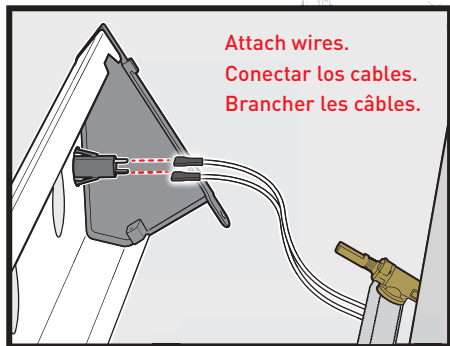
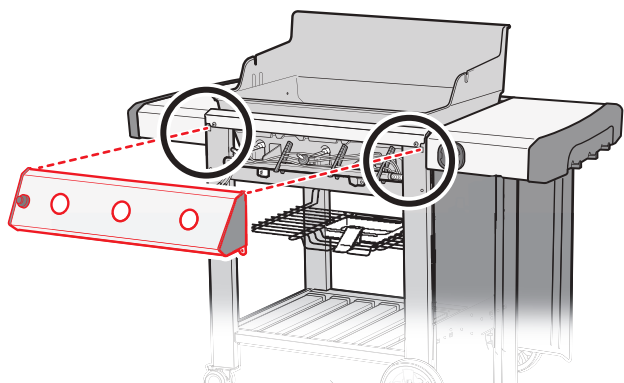

29

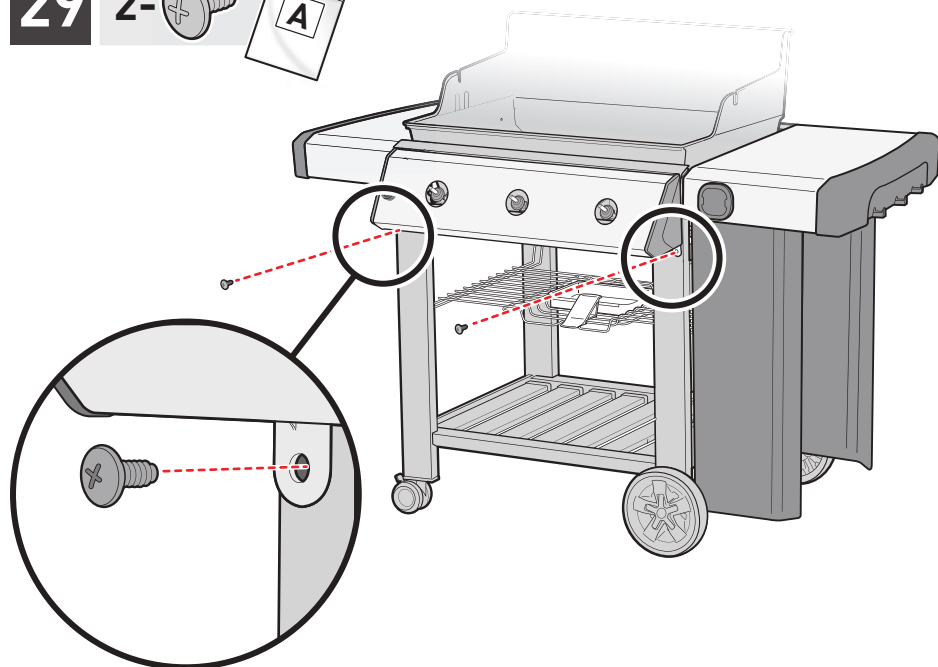
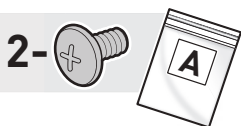

30

1-

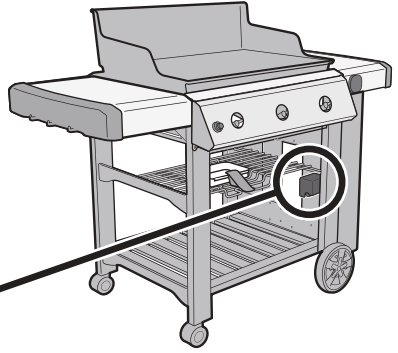
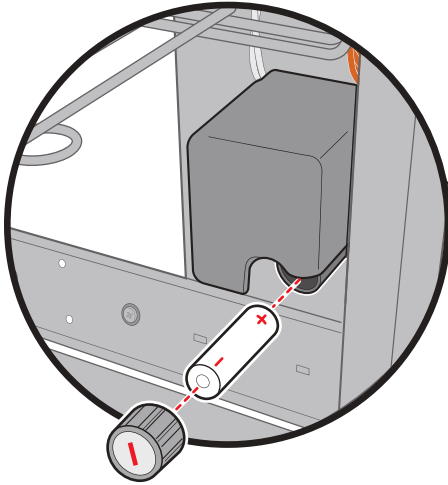

31

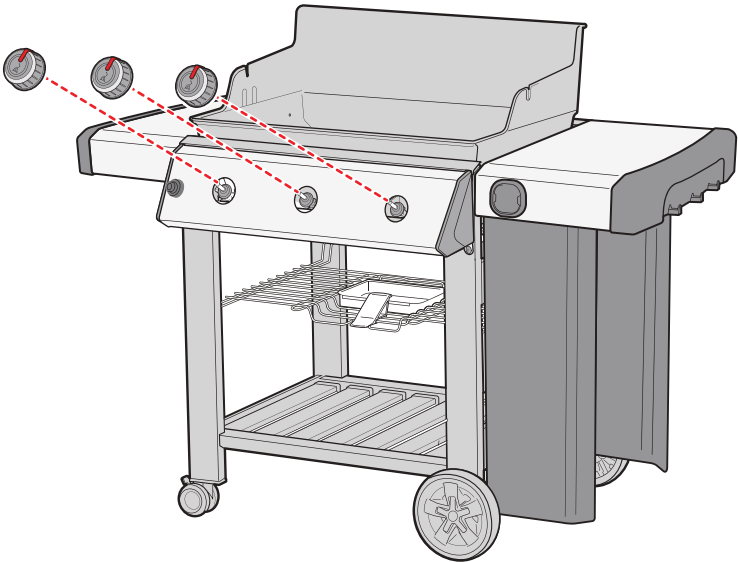

32

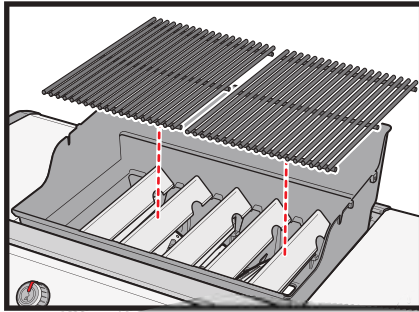
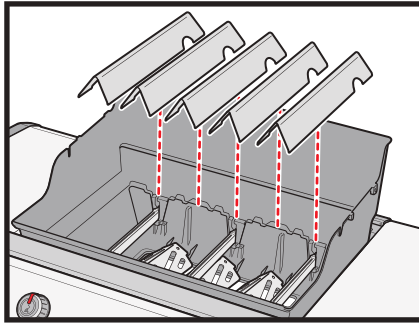
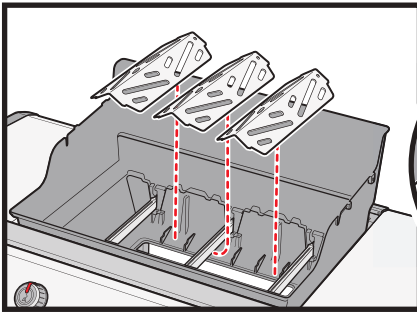

33

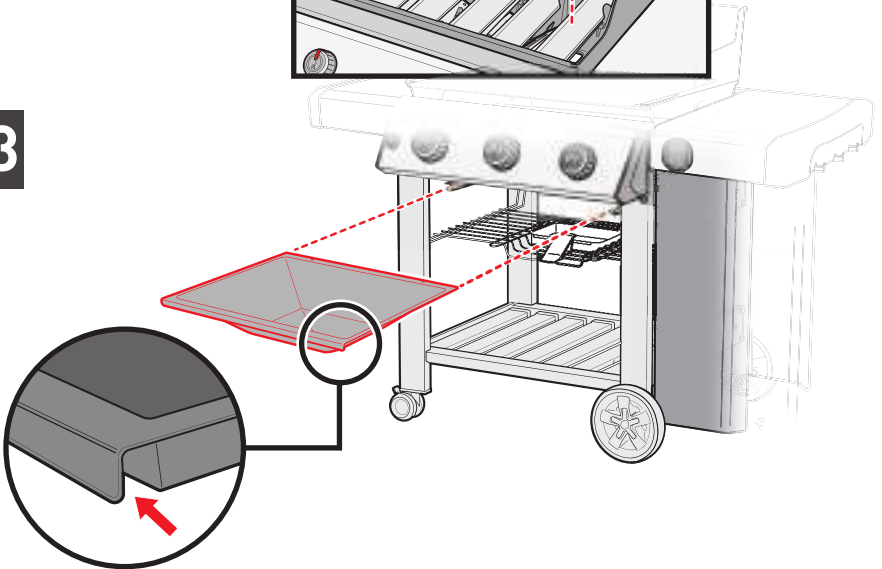

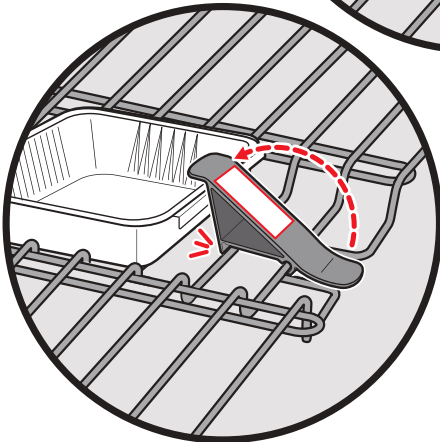
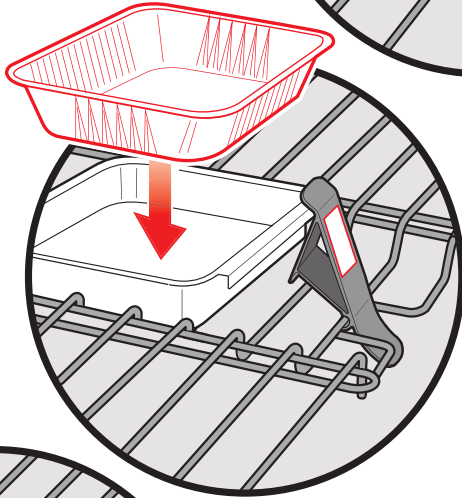
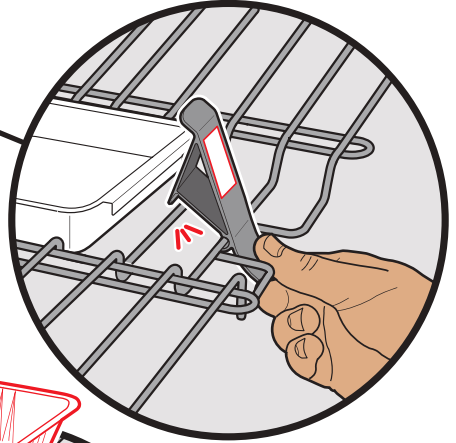
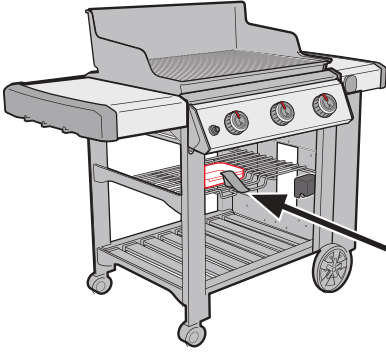

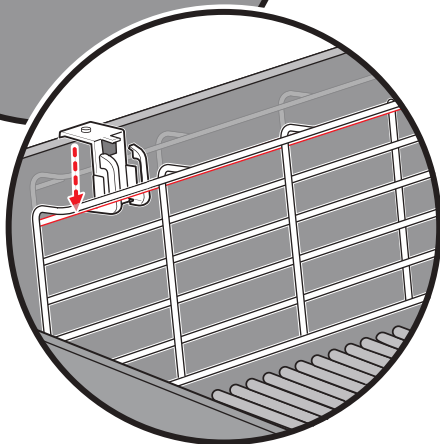
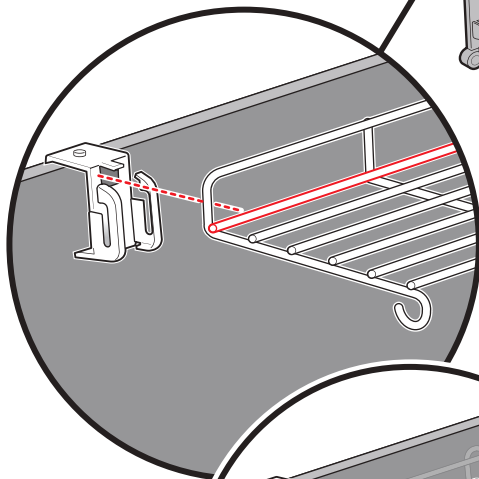
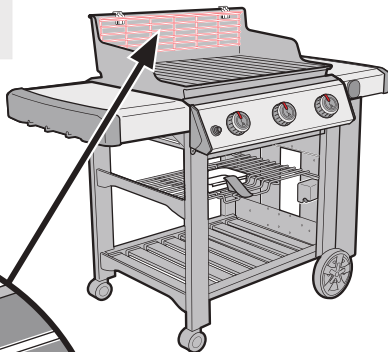

DOWN
ABAJO
BAS

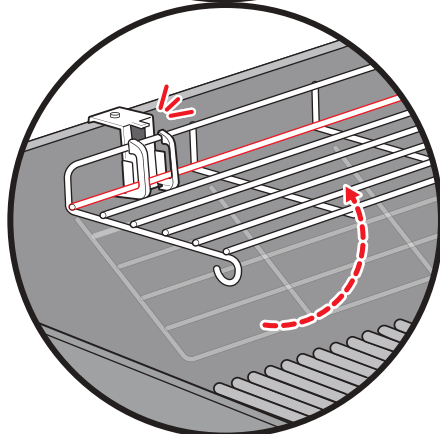

UP
ARRIBA
HAUT

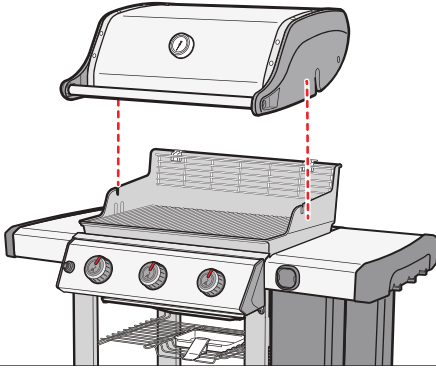
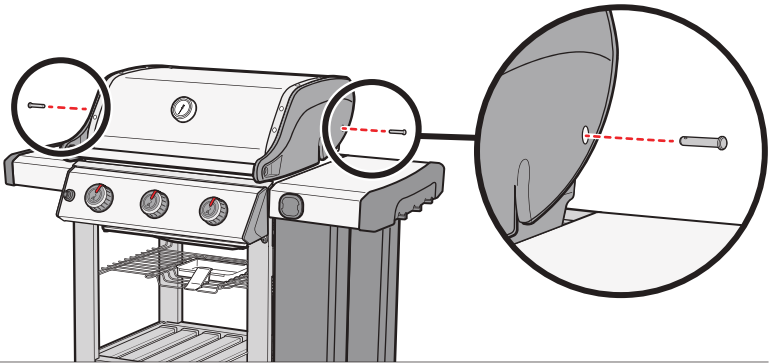
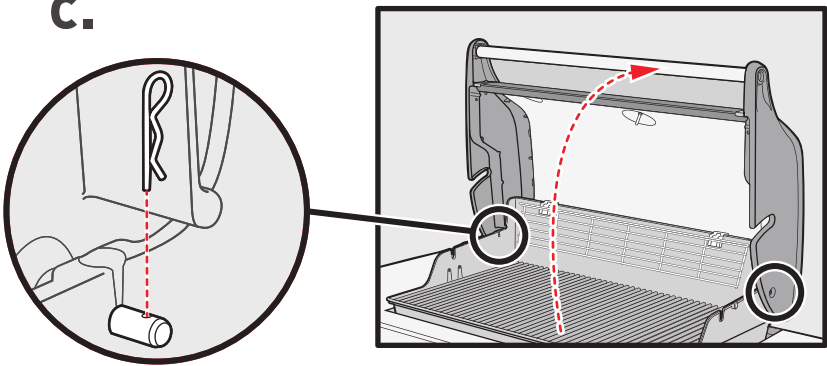
36**a.****b.****c.****37**

- ⚠ Remove all packing material.
- ⚠ Retirar todo el material de embalaje.
- ⚠ Retirer l'emballage.

Register Today.
Regístrate hoy.
Enregistrez-le aujourd'hui.



U.S.:
1-800-446-1071

EE. UU.:
1-800-446-1071

États-Unis :
1 800 446-1071



Mexico:
01 800 0093237

México:
01 800 0093237

Mexique :
01 800 0093237



Canada:
1-800-446-1071

Canadá:
1-800-446-1071

Canada :
1 800 446-1071

Apple and the Apple logo are trademarks of Apple Inc., registered in the U.S. and other countries. App Store is a service mark of Apple Inc. Android and Google Play are trademarks of Google Inc.

Apple y el logotipo de Apple son marcas comerciales de Apple Inc., registradas en EE. UU. y otros países. App Store es una marca de servicio de Apple Inc. Android y Google Play son marcas comerciales de Google Inc.

Apple et le logo d'Apple sont des marques de commerce d'Apple Inc. déposées aux États-Unis et dans d'autres pays. App Store est une marque de service d'Apple Inc. Android et Google Play sont des marques de commerce de Google Inc.

GENESIS II

E-210™ • E-310™ • E-410™ • SE-410™ • E-610™ LP

OWNER'S MANUAL



LET'S GRILL



► **Unlock grilling happiness:** Register your Genesis® II gas grill and receive special content to make you the ultimate backyard hero.

Registration is easy and we only ask a few quick questions. In less than two minutes, activate your unique WeberID, and unlock a lifetime of Weber knowledge and guidance. Stay inspired along the way.



PHONE
800-446-1071



MOBILE
weber.com
/register



EMAIL
support@
weberstephen.com



ONLINE
weber.com
/register



FOR LIFE

Keep this Owner's Manual for future reference, thoroughly read through it, and if you have any questions please contact us today- you can find our number at the back of this manual or email us at support@weberstephen.com.

welcome to
**THE WORLD OF
 WEBER**

We are so glad that you have joined us on the journey to backyard happiness. Please take some time to read through this Owner's Manual to ensure that you are up and grilling quickly and easily. We want to be with you for the life of your grill, so please take just a couple of minutes to register your grill. We promise that we will never sell your information or spam you with unnecessary emails. What we do promise is to be by your side, every step of the way. By signing up for your WeberID, as part of your registration, we will deliver special content just for you and your grill to enjoy.

So, come along and join us online, on the phone, or however else you'd like to stay in touch.

Thank you for choosing Weber. We are happy you are here.



**Important
 Safety Information**

DANGER, WARNING, and CAUTION statements are used throughout this Owner's Manual to emphasize critical and important information. Read and follow these statements to help ensure safety and prevent property damage. The statements are defined below.

⚠ DANGER: Indicates a hazardous situation which, if not avoided, *will result in death or serious injury.*

⚠ WARNING: Indicates a hazardous situation which, if not avoided, *could result in death or serious injury.*

⚠ CAUTION: Indicates a hazardous situation which, if not avoided, *could result in minor or moderate injury.*

⚠ DANGER

If you smell gas:

- Shut off gas to the appliance (grill).
- Extinguish any open flame.
- Open lid.
- If odor continues, keep away from the appliance (grill) and immediately call your gas supplier or your fire department.

USE OUTDOORS ONLY.

READ THE INSTRUCTIONS BEFORE USING THE APPLIANCE (GRILL).

⚠ WARNING

- Do not store or use gasoline or other flammable liquids or vapors in the vicinity of this (grill) or any other appliance.
- An LP cylinder (tank) not connected for use shall not be stored in the vicinity of this (grill) or any other appliance.

NOTICE TO INSTALLER: These instructions must be left with the consumer.

NOTICE TO CONSUMER: Retain these instructions for future reference.



Installation and Assembly

⚠ DANGER: This grill is not intended to be installed in or on recreational vehicles or boats.

⚠ WARNING: Do not use this grill unless all parts are in place and the grill was properly assembled according to the assembly instructions.

⚠ WARNING: Do not build this model of grill in any built-in or slide-in construction.

⚠ WARNING: Do not modify the appliance (grill). Liquid propane gas is not natural gas. The conversion or attempted use of natural gas in a liquid propane gas unit or liquid propane gas in a natural gas unit is unsafe and will void your warranty.

- In the United States, installation must conform with local codes or, in the absence of local codes, with either the National Fuel Gas Code, ANSI Z223.1/NFPA 54, Natural Gas and Propane Installation Code, CSA B149.1; or Propane Storage and Handling Code, B149.2; or the Standard for Recreational Vehicles, ANSI A119.2/NFPA 1192, and CSA Z240 RV Series, Recreational Vehicle Code, as applicable.
- In Canada, the installation of this grill must comply with local codes and/or the latest edition of Standard CAN/CSA-B149.2 (Propane Storage and Handling Code). These instructions, while generally acceptable, do not necessarily comply with the Canadian installation codes, particularly with piping above and below ground.
- In Mexico, if there are local codes that apply to portable gas appliances, you must comply with the latest edition of Official Mexican Standard (NOM).
- If an external electrical source is utilized (such as a rotisserie) it must be electrically grounded in accordance with local codes or, in the absence of local codes, with the National Electrical Code, ANSI/NFPA 70, or the Canadian Electrical Code, Part 1, CSA C22.1.

Operation

⚠ DANGER: Only use the grill outdoors in a well-ventilated area. Do not use in a garage, building, breezeway, tent, any other enclosed area, or beneath overhead combustible construction.

⚠ DANGER: Do not use the grill in any vehicle or in any storage or cargo area of any vehicle. This includes, but is not limited to, cars, trucks, station wagons, mini-vans, sport utility vehicles, recreational vehicles, and boats.

⚠ DANGER: Do not use the grill within 24 inches (61 cm) of combustible materials. This includes the top, bottom, back and sides of the grill.

⚠ DANGER: Keep the cooking area clear of flammable vapors and liquids such as gasoline, alcohol, etc., and combustible materials.

⚠ DANGER: This appliance (grill) must be kept away from flammable materials during use.

⚠ DANGER: Do not put a grill cover or anything flammable on, or in the storage area under the grill while it is in operation or is hot.

⚠ DANGER: Should a grease fire occur, turn off all burners and leave lid closed until fire is out.

⚠ WARNING: Accessible parts may be very hot. Keep young children away.

⚠ WARNING: The use of alcohol, prescription drugs, non-prescription drugs, or illegal drugs may impair the consumer's ability to properly and safely assemble, move, store, or operate the grill.

⚠ WARNING: Never leave the grill unattended during pre-heating or use. Exercise caution when using this grill. The entire cookbox gets hot when in use.

⚠ WARNING: Do not move the appliance (grill) during use.

⚠ WARNING: Keep any electrical supply cord and the fuel supply hose away from any heated surfaces.

- Do not use charcoal or lava rock in the grill.

Storage and/or Nonuse

⚠ WARNING: Turn off the gas supply at the gas cylinder (tank) after use.

⚠ WARNING: LP tanks must be stored outdoors out of the reach of children and must not be stored in a building, garage, or any other enclosed space.

⚠ WARNING: After a period of storage and/or nonuse, the grill should be checked for gas leaks and burner obstructions before use.

- Storage of the grill indoors is permissible only if the LP tank is disconnected and removed from the grill.

California Proposition 65

⚠ WARNING: Combustion byproducts produced when using this product contain chemicals known to the state of California to cause cancer, birth defects, or other reproductive harm.

⚠ WARNING: Handling the brass material on this product exposes you to lead, a chemical known to the state of California to cause cancer, birth defects, or other reproductive harm. Wash hands after handling this product.

TABLE OF CONTENTS

2	Welcome to Weber Important Safety Information
4	Product Features The GS4™ Grilling System Genesis® II Features
6	Tips and Hints The Flame - Direct or Indirect Grilling Do's and Don'ts
8	The Weber Promise Warranty
9	Getting Started Important Information about LP Gas & Gas Connections LP Tank Installation & Leak Checking Refilling or Replacing an LP Tank
12	Operation The Very First Time You Grill Every Time You Grill Igniting the Grill
14	Product Care Cleaning and Maintenance
16	Troubleshooting
18	Grilling Guide



**ALWAYS
HAVE THE
LATEST AND
GREATEST**

The most recent version of this owner's manual can be found online.

The grills illustrated in this Owner's Manual may vary slightly from the model purchased.

THE GS4™ GRILLING SYSTEM

The GS4™ High Performance Grilling System sets a new standard in the world of backyard cuisine, and lands the Genesis® II and Genesis® II LX series of gas grills in a class of their own. This innovative grilling system is based on over 30 years of grilling experience, culinary expertise, and most importantly, avidly considering the wants and needs of the people who matter most – the grilling community.

Each component of GS4™ was uniquely designed for ease-of-use and to provide an unequalled satisfaction to your backyard grilling experience. Promising burners that are ensured to ignite every time, smoke infused food that grills evenly and consistently regardless of where it's placed on the cooking grate, and hassle free cleanup, so that you are able to focus on what it's all about – bringing people together around the grill.

The GS4™ grilling system is composed of four key components: The E2i™ Electronic Ignition, High Performance Burners, Flavorizer™ Bars, and Grease Management System. These components ensure that every aspect of your grilling experience is easy and reliable; from the moment the burners are lit to the general maintenance of your grill. And together, create the strongest grilling engine within every Genesis® II and Genesis® II LX grill.



1 E2i™ Electronic Ignition

The E2i™ Electronic Ignition is ensured to ignite every time. Backed by a generous warranty, rest assured that you'll be up-and-grilling the first time, every time.

2 High Performance Burners

The unique, tapered shape delivers a consistent gas flow from front to back. This provides ultimate heat distribution, ensuring that food grills evenly and consistently anywhere on the cooking grate.

3 Flavorizer™ Bars

The classic Weber® Flavorizer™ bars are angled just right to catch drippings that smoke and sizzle, adding that irresistible smoky flavor that we all know and love to your food. Any drippings not vaporized follow the slope and are funneled away from the burners, down into the grease management system.

4 Grease Management System

The grease management system helps with the removal of grease while reducing the risk of flare-ups. Drippings that are not vaporized by the Flavorizer™ bars are funneled away from the burners into the disposable drip tray, located within the catch pan under the cookbox. Simply remove the catch pan and replace the drip tray as needed.



4 TAKES LESS THAN TWO MINUTES

Genesis® II FEATURES



A Side Tables with Integrated Tool Hooks

Use the side tables to keep platters, seasonings, and tools within arm's reach. Hang your essential grilling tools on the hooks for easy access and organization of your backyard workspace. The side table folds down in models equipped with two and three burners.

B Built-In Thermometer

Being aware of the temperature inside of your grill allows you to adjust the heat when needed.

C Porcelain-Enameled, Cast Iron Cooking Grates

The reversible cooking grates empower you to be even more creative with your dish. The thin side of the cooking grate is ideal for delicate food such as fish and shrimp, while the wider side creates a thick sear mark enhancing the flavor of your food.

(SE-410™ equipped with stainless steel grates)

D Tuck-Away™ Warming Rack

The Tuck-Away™ warming rack keeps food warm or toasts burger buns, as the main meal grills below. The unique Tuck-Away™ feature allows you to fold it down when not in use, providing optimal grilling space and convenient in-the-grill storage.

E iGrill™ 3 Ready

The newest grilling essential- the iGrill™ 3 digital Bluetooth thermometer monitors your food from beginning to end, displaying the real-time temperature on your mobile device. Once you've downloaded the Weber iGrill™ app, connect the iGrill™ to Bluetooth, and run up to four thermometer probes from your grill to the food. (Sold separately.)

F Fuel Gauge

Always know where you stand. The easy-to-read fuel gauge located next to the gas tank lets you see how much fuel is left in your tank at all times. Rest assured knowing that you will not run out of gas halfway through your next grilling experience.

G Easy Access Gas Tank Storage

Mounting the gas tank to the outside of the grill makes the tank easy to access and remove; while also increasing storage space in the cart.

H Open Cart Design

The sleek open-cart design provides additional room and accessibility of your grilling tools.

The Flame- Direct or Indirect

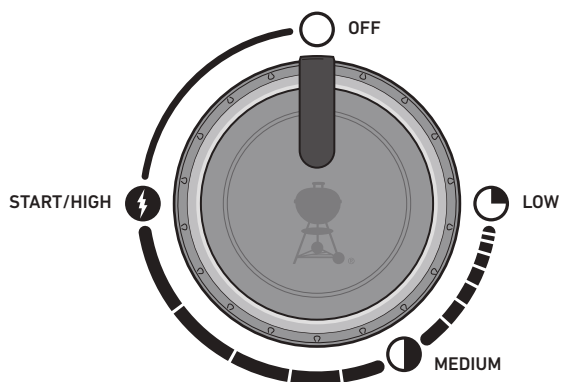

DIRECT HEAT SETUP

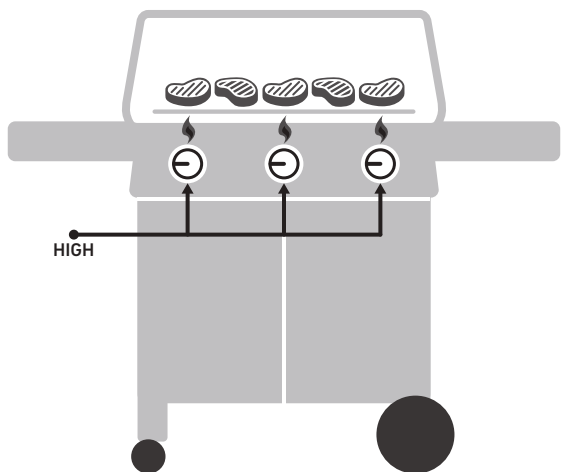

Use the direct method for small, tender pieces of food that take less than 20 minutes to cook, such as: hamburgers, steaks, chops, kabobs, boneless chicken pieces, fish fillets, shellfish, and sliced vegetables.

With direct heat, the fire is right below the food. It sears the surfaces of the food, developing flavors, texture, and delicious caramelization while cooking the food all the way to the center.

INDIRECT HEAT SETUP

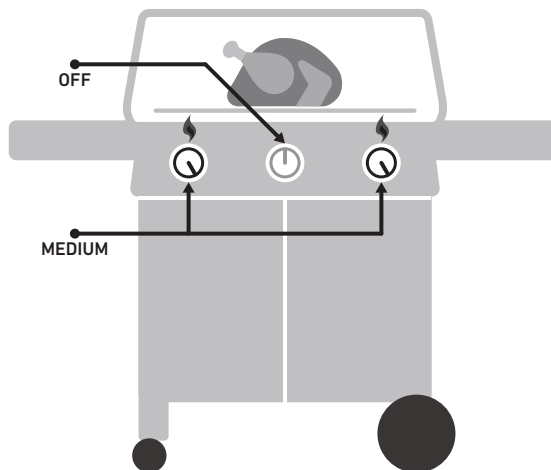

Use the indirect method for larger cuts of meat that require 20 minutes or more of grilling time, or for foods so delicate that direct exposure to the heat would dry them out or scorch them, such as: roasts, bone-in poultry pieces, whole fish, delicate fish fillets, whole chickens, turkeys, and ribs. Indirect heat can also be used for finishing thicker foods or bone-in cuts that have been seared or browned first over direct heat.

With indirect heat, the heat is on both sides of the grill, or off to one side of the grill. The food sits over the unlit part on the cooking grate.



Grilling Do's and Don'ts

Preheat each and every time.

If the cooking grates aren't hot enough, food will stick, and you will likely never have a chance of searing properly or developing those handsome grill marks. Even if a recipe calls for medium or low heat, always preheat the grill on the highest setting first. Open the lid, turn up the heat, close the lid, and then let the cooking grate heat up for about ten minutes or until the lid thermometer reads 500° F (260° C).

Don't grill on dirty grates.

Tossing food onto the cooking grates before they have been cleaned is never a good idea. Leftover "stuff" on the grates acts like glue, binding it to the grates and your new food. To avoid tasting last night's dinner on today's lunch, make sure you are grilling on a clean cooking grate. Once the grates are preheated, use a stainless steel bristle grill brush to make a clean, smooth surface.

Be present in the process.

Before firing up your grill, make sure that everything you need is within arm's reach. Don't forget your essential grilling tools, already oiled and seasoned food, glazes or sauces, and clean cooking platters for cooked food. Having to run back to your kitchen not only means missing out on the fun, but could also result in burning your food. French chefs call this "mise en place" (meaning, "put in place"). We call it "being present".

Create a little elbow room.

Packing too much food onto the cooking grates restricts your flexibility. Leave at least one-quarter of the cooking grates clear, with plenty of space between each food item, in order to get your tongs in there and easily move the food around. Sometimes grilling involves split-second decisions and the ability to jockey food from one area to another. So give yourself enough room to operate.

Try not to peek.

The lid on your grill is for more than just keeping the rain out. Most importantly, it's for preventing too much air from getting in, and too much heat and smoke from getting out. When the lid is closed, the cooking grates are hotter, the grilling times are faster, the smoky tastes are stronger, and the flare-ups are fewer. So put a lid on it!

Only flip once.

What's better than a juicy steak with a deep sear and plenty of beautifully caramelized bits? The key to accomplishing these results is to keep your food in place. Sometimes we have the tendency to flip our food before it reaches the desirable level of color and flavor. In nearly all cases, you should turn food just once. If fiddling with it more than that, you are probably also opening the lid too much, which causes its own set of problems. So step back and trust the grill.

Know when to tame the flame.

When grilling, sometimes the most important thing to know is when to stop. The most reliable way to test doneness of your food is to invest in an instant-read thermometer. This slim little gem will help you pinpoint that critical moment when your food is at its best.

Don't be afraid to experiment.

Back in the 1950s, grilling meant one thing: meat (and only meat) charred over open flames. The modern day backyard chef doesn't need a kitchen in order to prepare a full course meal. Use your grill to make char-grilled appetizers, sides, and even desserts. Register your grill to receive special content that will inspire you along the way. We'd love to join you on your grilling adventures.



SPATULA

Look for a long-handled spatula designed with a bent (offset) neck so that the blade is set lower than the handle. This makes it easier to lift food off the cooking grates.



TIMER

Avoid the disappointment of torching your dinner by simply setting a timer. Nothing fancy needed—just one that is reliable and easy to use.

The Weber Promise

At Weber, we pride ourselves on two things: making grills that last and providing a lifetime of excellent customer service.

Warranty

Thank you for purchasing a Weber product. Weber-Stephen Products LLC, 1415 S. Roselle Road, Palatine, Illinois 60067 ("Weber") prides itself on delivering a safe, durable, and reliable product.

This is Weber's Voluntary Warranty provided to you at no extra charge. It contains the information you will need to have your Weber product repaired in the unlikely event of a failure or defect.

Pursuant to applicable laws, the customer has several rights in case the product is defective. Those rights include supplementary performance or replacement, abatement of the purchasing price, and compensation. In the European Union, for example, this would be a two-year statutory warranty starting on the date of the handover of the product. These and other statutory rights remain unaffected by this warranty provision. In fact, this warranty grants additional rights to the Owner that are independent from statutory warranty provisions.

Weber's Voluntary Warranty

Weber warrants, to the purchaser of the Weber product (or in the case of a gift or promotional situation, the person for whom it was purchased as a gift or promotional item), that the Weber product is free from defects in material and workmanship for the period(s) of time specified below when assembled and operated in accordance with the accompanying Owner's Manual. (Note: If you lose or misplace your Weber Owner's Manual, a replacement is available online at www.weber.com, or such country-specific website to which Owner may be redirected.) Under normal, private single family home or apartment use and maintenance, Weber agrees within the framework of this warranty to repair or replace defective parts within the applicable time periods, limitations, and exclusions listed below. **TO THE EXTENT ALLOWABLE BY APPLICABLE LAW, THIS WARRANTY IS EXTENDED ONLY TO THE ORIGINAL PURCHASER AND IS NOT TRANSFERABLE TO SUBSEQUENT OWNERS, EXCEPT IN THE CASE OF GIFTS AND PROMOTIONAL ITEMS AS NOTED ABOVE.**

Owner's Responsibilities Under this Warranty

To ensure trouble-free warranty coverage, it is important (but it is not required) that you register your Weber product online at www.weber.com, or such country-specific website to which Owner may be redirected. Please also retain your original sales receipt and/or invoice. Registering your Weber product confirms your warranty coverage and provides a direct link between you and Weber in case we need to contact you.

The above warranty only applies if the Owner takes reasonable care of the Weber product by following all assembly instructions, usage instructions, and preventative maintenance as outlined in the accompanying Owner's Manual, unless the Owner can prove that the defect or failure is independent of non-compliance with the above mentioned obligations. If you live in a coastal area, or have your product located near a pool, maintenance includes regular washing and rinsing of the exterior surfaces as outlined in the accompanying Owner's Manual.

Warranty Handling / Exclusion of Warranty

If you believe that you have a part which is covered by this Warranty, please contact Weber Customer Service using the contact information on our website (www.weber.com, or such country-specific website to which Owner may be redirected). Weber will, upon investigation, repair or replace (at its option) a defective part that is covered by this Warranty. In the event that repair or replacement are not possible, Weber may choose (at its option) to replace the grill in question with a new grill of equal or greater value. Weber may ask you to return parts for inspection, shipping charges to be pre-paid.

This WARRANTY lapses if there are damages, deteriorations, discolorations, and/or rust for which Weber is not responsible caused by:

- Abuse, misuse, alteration, modification, misapplication, vandalism, neglect, improper assembly or installation, and failure to properly perform normal and routine maintenance;
- Insects (such as spiders) and rodents (such as squirrels), including but not limited to damage to burners and/or gas hoses;
- Exposure to salt air and/or chlorine sources such as swimming pools and hot tubs/spas;
- Severe weather conditions such as hail, hurricanes, earthquakes, tsunamis or surges, tornadoes or severe storms.

The use and/or installation of parts on your Weber product that are not genuine Weber parts will void this Warranty, and any damages that result hereby are not covered by this Warranty. Any conversion of a gas grill not authorized by Weber and performed by a Weber authorized service technician will void this Warranty.

Product Warranty Periods

- Cookbox:**
10 years, no rust through/burn through
(2 years paint excluding fading or discoloration)
- Lid assembly:**
10 years, no rust through/burn through
(2 years paint excluding fading or discoloration)
- Stainless steel burners:**
10 years, no rust through/burn through
- Stainless steel cooking grates:**
10 years, no rust through/burn through
- Stainless steel Flavorizer™ bars:**
10 years, no rust through/burn through
- Ignition system (module, electrode assembly, wiring, and switch):**
10 years, ignition start
(excluding battery and battery damage)
- Grease management system (slide-out grease tray and catch pan):**
10 years, no rust through/burn through
- Porcelain-enameled cast iron cooking grates:**
5 years, no rust through/burn through
- Porcelain-enameled Flavorizer™ bars:**
5 years, no rust through/burn through
- All remaining parts:**
2 years

Disclaimers

APART FROM THE WARRANTY AND DISCLAIMERS AS DESCRIBED IN THIS WARRANTY STATEMENT, THERE ARE EXPLICITLY NO FURTHER WARRANTY OR VOLUNTARY DECLARATIONS OF LIABILITY GIVEN HERE WHICH GO BEYOND THE STATUTORY LIABILITY APPLYING TO WEBER. THE PRESENT WARRANTY STATEMENT ALSO DOES NOT LIMIT OR EXCLUDE SITUATIONS OR CLAIMS WHERE WEBER HAS MANDATORY LIABILITY AS PRESCRIBED BY STATUTE.

NO WARRANTIES SHALL APPLY AFTER THE APPLICABLE PERIODS OF THIS WARRANTY. NO OTHER WARRANTIES GIVEN BY ANY PERSON, INCLUDING A DEALER OR RETAILER, WITH RESPECT TO ANY PRODUCT (SUCH AS ANY "EXTENDED WARRANTIES"), SHALL BIND WEBER. THE EXCLUSIVE REMEDY OF THIS WARRANTY IS REPAIR OR REPLACEMENT OF THE PART OR PRODUCT.

IN NO EVENT UNDER THIS VOLUNTARY WARRANTY SHALL RECOVERY OF ANY KIND BE GREATER THAN THE AMOUNT OF THE PURCHASE PRICE OF THE WEBER PRODUCT SOLD.

YOU ASSUME THE RISK AND LIABILITY FOR LOSS, DAMAGE, OR INJURY TO YOU AND YOUR PROPERTY AND/OR TO OTHERS AND THEIR PROPERTY ARISING OUT OF THE MISUSE OR ABUSE OF THE PRODUCT OR FAILURE TO FOLLOW INSTRUCTIONS PROVIDED BY WEBER IN THE ACCOMPANYING OWNER'S MANUAL.

PARTS AND ACCESSORIES REPLACED UNDER THIS WARRANTY ARE WARRANTED ONLY FOR THE BALANCE OF THE ABOVE MENTIONED ORIGINAL WARRANTY PERIOD(S).

THIS WARRANTY APPLIES TO PRIVATE SINGLE FAMILY HOME OR APARTMENT USE ONLY AND DOES NOT APPLY TO WEBER GRILLS USED IN COMMERCIAL, COMMUNAL OR MULTI-UNIT SETTINGS SUCH AS RESTAURANTS, HOTELS, RESORTS, OR RENTAL PROPERTIES.

WEBER MAY FROM TIME TO TIME CHANGE THE DESIGN OF ITS PRODUCTS. NOTHING CONTAINED IN THIS WARRANTY SHALL BE CONSTRUED AS OBLIGATING WEBER TO INCORPORATE SUCH DESIGN CHANGES INTO PREVIOUSLY MANUFACTURED PRODUCTS, NOR SHALL SUCH CHANGES BE CONSTRUED AS AN ADMISSION THAT PREVIOUS DESIGNS WERE DEFECTIVE.

WEBER-STEPHEN PRODUCTS LLC
Customer Service Center
1415 S. Roselle Road
Palatine, IL 60067
U.S.A.

For replacement parts, call:
1-800-446-1071



Important Information about LP Gas & Gas Connections

What Is LP Gas?

Liquefied petroleum gas, also called LP, LP gas, liquid propane, or simply propane or butane, is the flammable, petroleum-based product used to fuel your grill. It is a gas at moderate temperatures and pressure when it is not contained. But at moderate pressure inside a container, such as a tank, LP is a liquid. As pressure is released from the tank, the liquid readily vaporizes and becomes LP gas.

Safe Handling Tips For LP Tanks

- A dented or rusty liquid propane tank may be hazardous and should be checked by your liquid propane supplier. Do not use a liquid propane tank with a damaged valve.
- Although your liquid propane tank may appear to be empty, gas may still be present, and the tank should be transported and stored accordingly.
- The LP tank must be installed, transported, and stored in an upright, secure position. LP tanks should not be dropped or handled roughly.
- Never store or transport the LP tank where temperatures can reach 125° F (51.7° C) (the tank will become too hot to hold by hand).
- Place dust cap on tank valve outlet whenever the tank is not in use. Only install the type of dust cap on the tank valve outlet that is provided with the tank valve. Other types of caps or plugs may result in leakage of propane.

LP Tank Requirements

- The tank must be approximately 18¼ inches high and 12¼ inches in diameter with a marked 20 lb. LPG capacity or 47.6 lb. water capacity as stated by the manufacturer. Other tanks may be acceptable provided they are compatible with the grill retention means (tank scale).
- The tank used must be constructed and marked in accordance with the Specifications for LP gas Cylinders of the U.S. Department of Transportation (D.O.T.); or the Canadian Standard for Cylinders, Spheres and Tubes for Transportation of Dangerous Goods and Commission, CAN/CSA-B339, as applicable.
- Tanks must be provided with a listed OPD (Overfilling Prevention Device) and a Type 1 (CGA 810) tank connection. The tank connection must be compatible with the grill connection.
- The tank must include a collar to protect the tank valve.
- Tanks must have a D.O.T. certification (A), and a testing date (B) that is within five years of current use.

What is a Regulator?

Your gas grill is equipped with a pressure regulator, which is a device to control and maintain uniform gas pressure as gas is released from the LP tank.

Regulator Requirements

- The regulator and hose assembly supplied with this grill must be used. This regulator has a flow limiting device built into the unit that will restrict the flow of gas in the event that a leak is detected.
- Replacement regulator and hose assemblies must be as specified by Weber-Stephen Products LLC (UL-listed Type 1 (CGA 810) tank connection device as described in the latest edition of ANSI Z21.81).

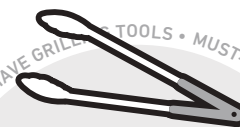
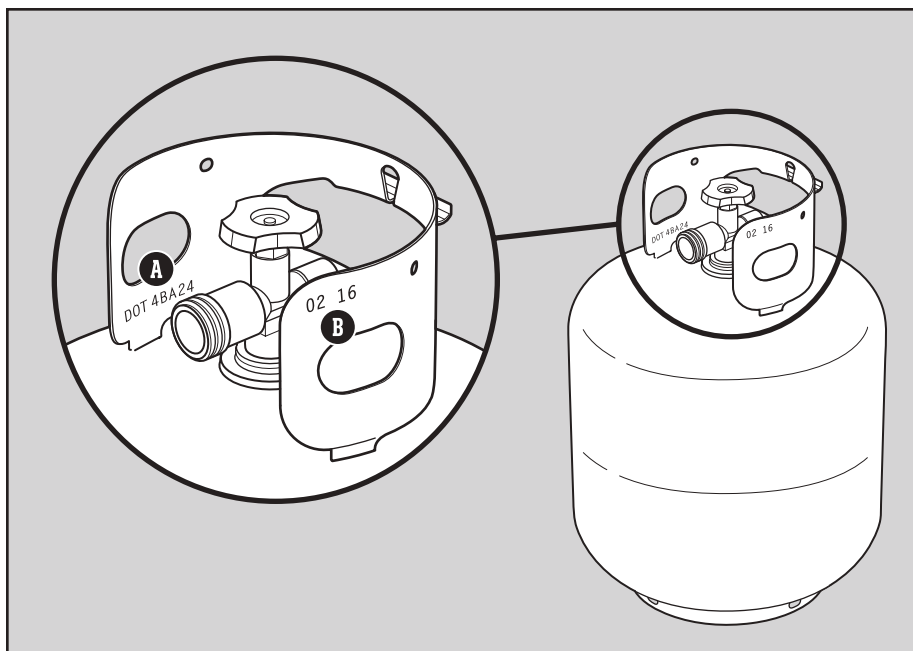

TONGS

Consider these to be an extension of your hand. The best tongs should have an effortless tension mechanism, comfortable hand grips, and a lock to keep them compact.



BRUSH AND MOP

Look for a basting brush with heat-resistant silicone bristles and a long handle, and a mop with long, cotton threads that sop up the thinner, vinegar-based sauces.

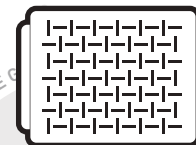

GRILLING PAN

Designed for food that is either too small or too delicate for the cooking grates, a perforated grilling pan keeps food right where it ought to be—on the grill, not in it.

LP Tank Installation & Leak Checking

Installation Location

The tank is hung onto the tank scale which is located outside the cabinet base under the right side table. The shape of the collar assembly (the metal protective ring around the tank valve) determines one of two directions in which the tank will correctly hang on the tank scale (A).

Inspect the Tank

- 1) Confirm that the tank valve is fully closed. Close by turning valve clockwise.
- 2) Confirm that the tank valve is the proper mating type for the regulator (B).
- 3) Inspect the tank valve, including the internal rubber seal for damage or debris (C). If damaged, return tank to local retailer.

Install The Tank

- 1) Check that all burner control knobs are in the off \bigcirc position. Check by pushing in and turning knobs clockwise.
- 2) Loosen hand nut and rotate tank lock up (D).
- 3) Lift tank into position on the tank scale (E).
- 4) Rotate the tank lock down. Tighten the hand nut.
- 5) Screw the regulator coupling onto the tank valve, turning clockwise (F). **Hand-tighten only.** Using a wrench could damage the regulator coupling and could cause a leak. Proceed to "CHECKING FOR GAS LEAKS."

What is a Leak Check?

Once the LP tank is properly installed, it is necessary to perform a leak check. A leak check is a reliable way to verify that gas is not escaping after you connect the tank. The fitting where the regulator connects to the tank should be tested each time a tank is refilled and reinstalled.

Checking for Gas Leaks

- 1) Wet fittings (G) with a soap and water solution, using a spray bottle, brush, or rag. You can make your own soap and water solution by mixing 20% liquid soap with 80% water; or, you can purchase leak check solution in the plumbing section of any hardware store.
- 2) Slowly open gas supply by turning tank valve counterclockwise while checking for bubbles.
- 3) If bubbles appear there is a leak:
 - a) If the leak is at the cylinder (H), turn off the gas. **DO NOT OPERATE THE GRILL.** Disconnect the tank and return the tank to your local retailer.
 - b) If the leak is at the regulator (I), turn off the gas. **DO NOT OPERATE THE GRILL.** Contact the Customer Service Representative in your area using the contact information on our website.
- 4) If bubbles do not appear, leak checking is complete:
 - a) Turn gas supply off at the tank and rinse connections with water.

NOTE: Since some leak test solutions, including soap and water, may be slightly corrosive, all connections should be rinsed with water after checking for leaks.

Additional Leak Check Precautions

The fuel system in your grill features other connections and fittings. These factory-made connections have been thoroughly checked for gas leaks and the burners have been flame-tested. However, it is recommended that a thorough leak check be performed annually. Instructions for this can be found online at weber.com.

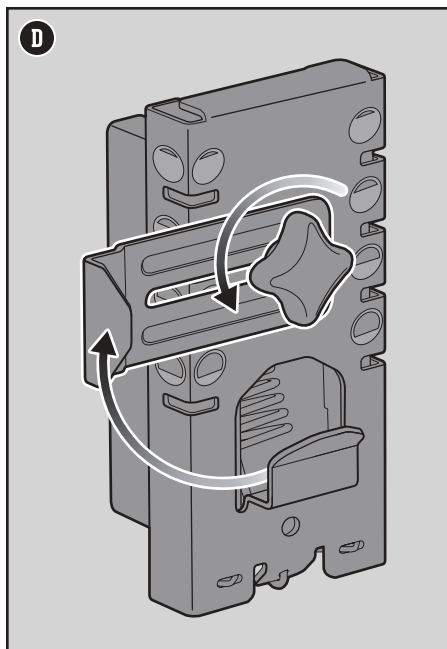
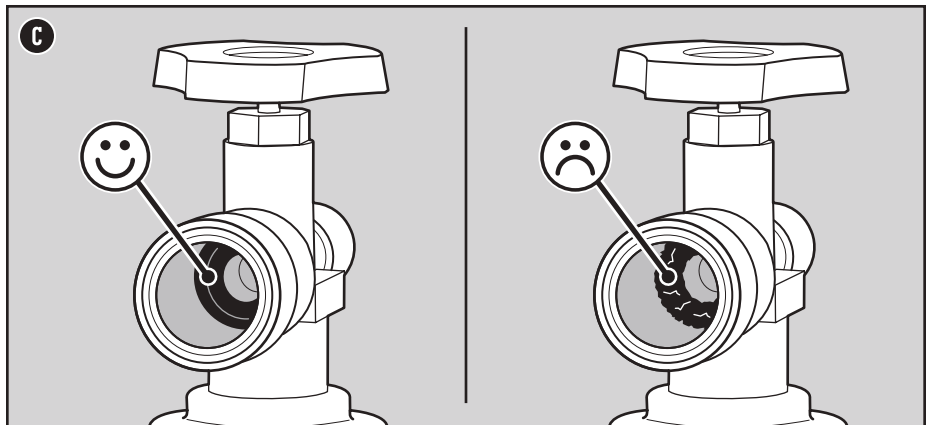
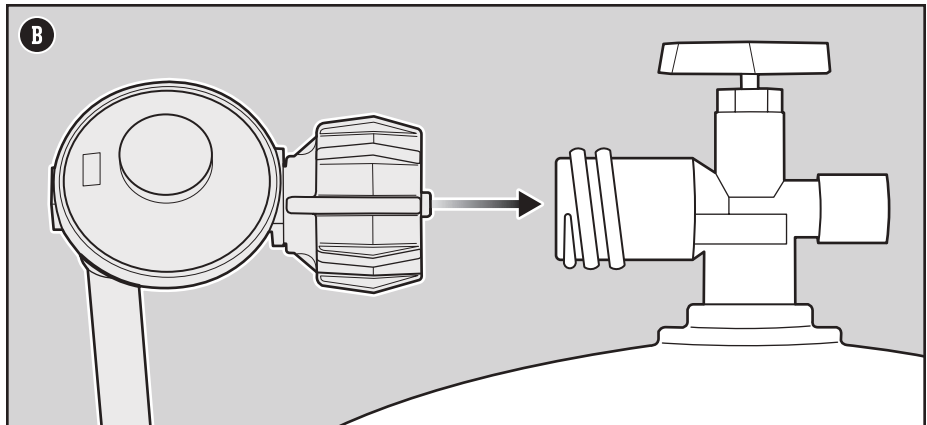
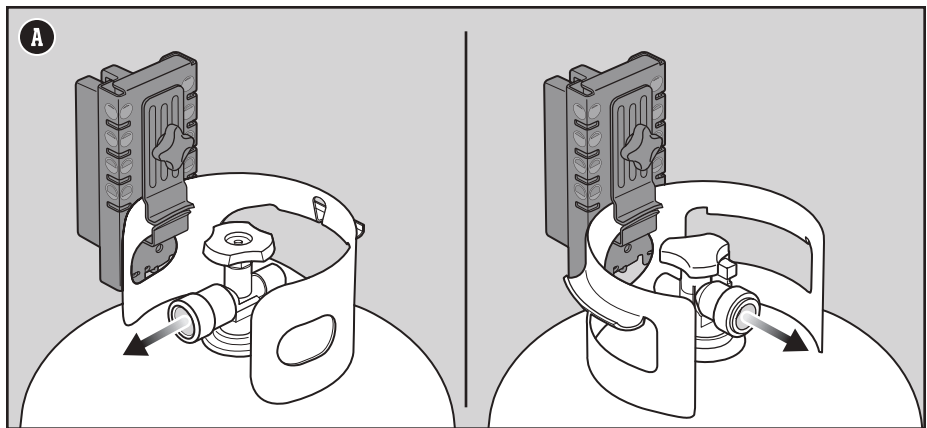

⚠ DANGER: Do not use a flame to check for gas leaks. Be sure there are no sparks or open flames in the area while you check for leaks.

⚠ DANGER: Leaking gas may cause a fire or explosion.

⚠ DANGER: Do not operate the grill if there is a gas leak present.

⚠ DANGER: If you see, smell, or hear the hiss of gas escaping from the liquid propane tank:

1. Move away from liquid propane tank.
2. Do not attempt to correct the problem yourself.
3. Call your fire department.

⚠ DANGER: Always close the tank valve before disconnecting the regulator. Do not attempt to disconnect the gas regulator and hose assembly or any gas fitting while this grill is in operation.

⚠ DANGER: Do not store a spare LP tank under or near this grill. Never fill the cylinder beyond 80% full. Failure to follow these statements exactly may result in a fire causing death or serious injury.

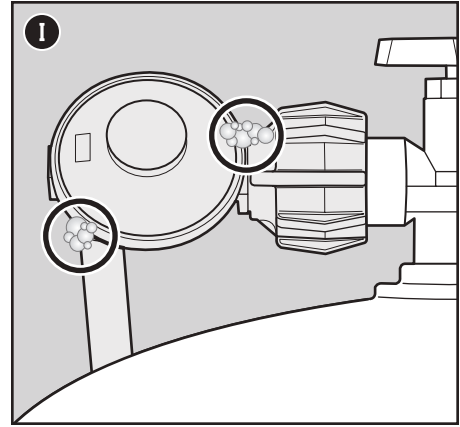
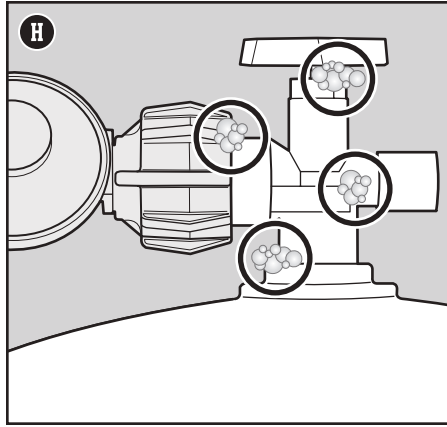
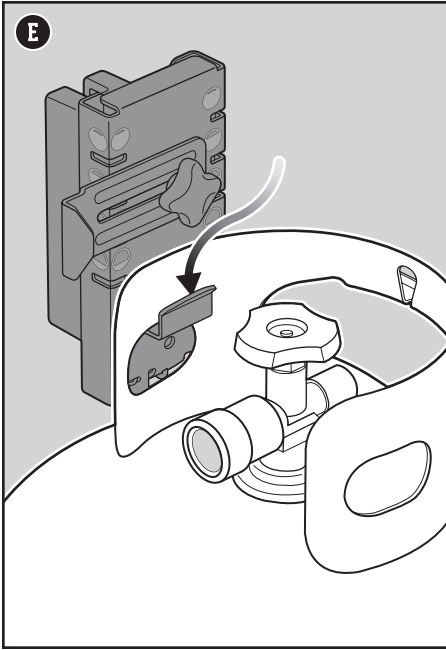

Refilling or Replacing an LP Tank

How Much Fuel is in the Tank?

The tank scale indicates the amount of fuel in a standard 20 lb. tank once the tank is hung from the scale. The fuel level is checked by viewing the red level indicator line, located on scale. When the indicator line is at the top, the tank is full (J). When it is at the bottom, the tank is empty (K) and needs to be removed to replace or refill.

Removal of the LP Tank

- 1) Confirm that the tank valve is fully closed. Close by turning valve clockwise (L).
- 2) Unscrew regulator coupling by turning counterclockwise by hand (M).
- 3) Loosen tank hand nut and turn tank lock up out of the way.
- 4) Lift tank off tank scale.

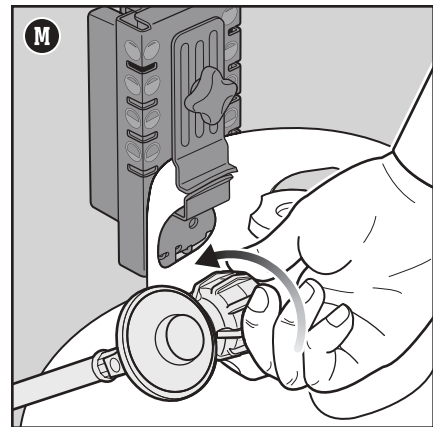
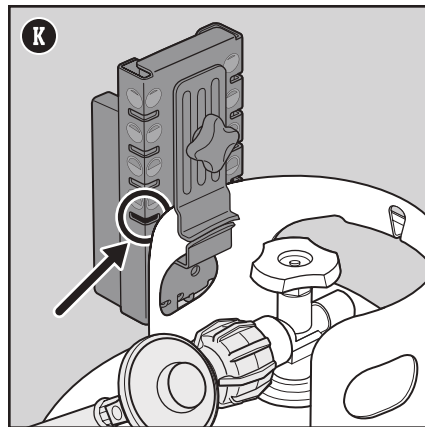
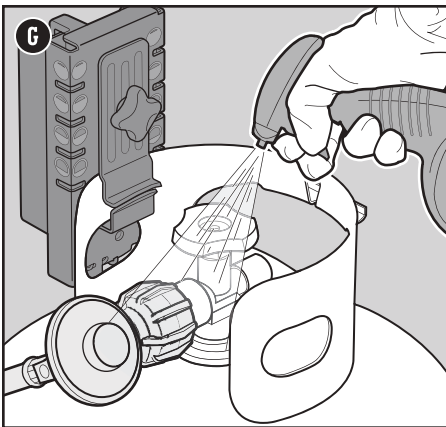
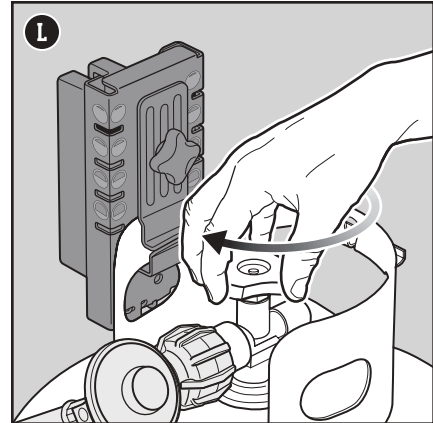
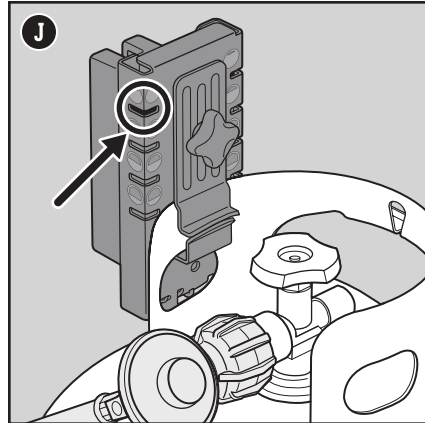
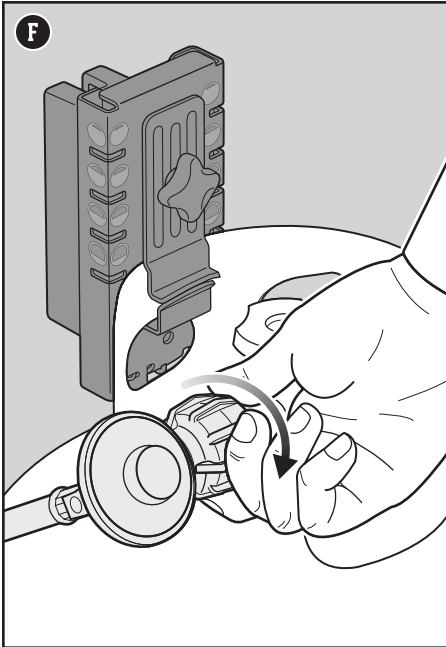

The Very First Time You Grill

Perform an Initial Burn-Off

Heat the grill on the highest setting, with the lid closed, for at least 20 minutes prior to grilling for the first time.

Every Time You Grill

Meal-to-Meal Maintenance

The Meal-To-Meal Maintenance plan includes the following simple, yet important, steps that should always be performed prior to grilling.

Check for Grease

Your grill was built with a grease management system that funnels grease away from food and into a disposable container. As you cook, grease is channeled down the slide-out grease tray and into a disposable drip tray that lines the catch pan. This system should be cleaned each and every time you grill to prevent fires.

- 1) Confirm that the grill is off and cool.
- 2) Remove the slide-out grease tray by pulling the tray out of the cabinet (A). Remove excess grease with a plastic scraper.
- 3) Remove the catch pan by pressing down on the catch pan latch (B). Check for excessive amounts of grease in the disposable drip tray that lines the catch pan. Discard disposable drip pan when necessary and replace with a new one.
- 4) Reinstall all components.

Inspect the Hose

Routine inspection of the hose is necessary.

- 1) Confirm that the grill is off and cool.
- 2) Check hose for any signs of cracking, abrasions, or cuts (C). If the hose is found to be damaged in any way, do not use the grill.

Preheat the Grill

Preheating the grill is critical to successful grilling. Preheating helps to prevent food from sticking to the grate and gets the grate hot enough to sear properly. It also burns off residue of a previously cooked meal.

- 1) Open the grill lid.
- 2) Ignite your grill according to the ignition instructions in this Owner's Manual.
- 3) Close lid.
- 4) Preheat the grill with all burners on the start/high  position for 10 to 15 minutes or until thermometer registers 500° F (260° C) (D).

Clean the Cooking Grate

After preheating, any bits of food or debris left over from previous use will be easier to remove. Cleaned grates will also prevent your next meal from sticking.

- 1) Brush the grates with a stainless steel bristle grill brush immediately after preheating (E).

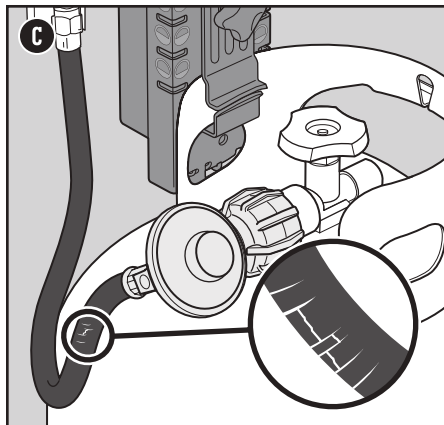
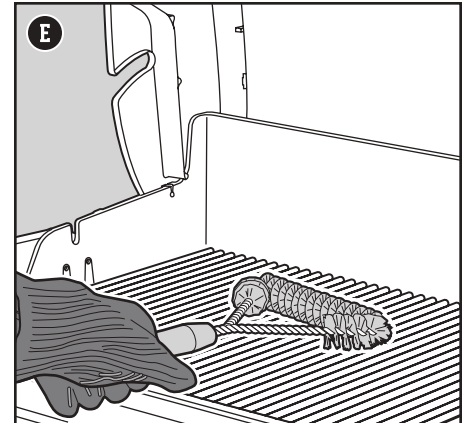
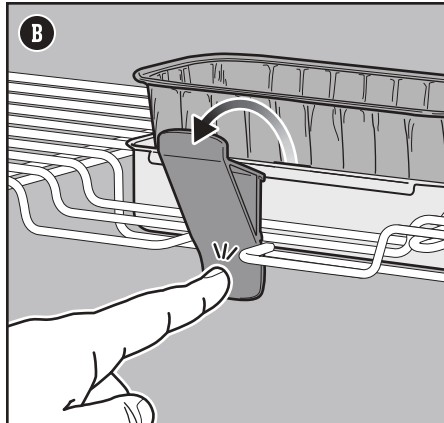
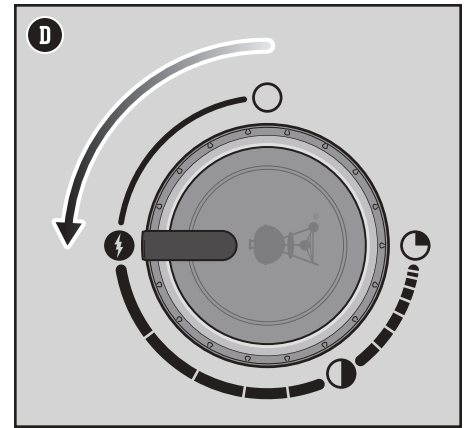
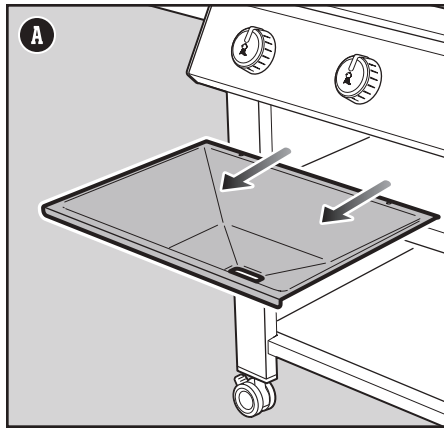

⚠ DANGER: Do not line the slide-out grease tray or cookbox with aluminum foil.

⚠ DANGER: Check the slide-out grease tray and catch pan for grease build-up before each use. Remove excess grease to avoid a grease fire.

⚠ WARNING: Use heat-resistant barbecue mitts or gloves when operating grill.

⚠ WARNING: Grill brushes should be checked for loose bristles and excessive wear on a regular basis. Replace brush if any loose bristles are found on cooking grates or brush. Weber recommends purchasing a new stainless steel bristle grill brush at the beginning of every spring.

⚠ WARNING: If the hose is found to be damaged in any way, do not use the grill. Replace using only Weber authorized replacement hose.





⚠ WARNING: Keep ventilation openings around tank clear and free of debris.



Igniting the Grill

Using the Electronic Ignition System to Ignite the Grill

Each control knob operates an individual burner, and each burner ignites independently. Ignite the burners starting from left to right. All burners should be lit for preheating, however, all burners do not have to be lit while grilling.

- 1) Open the grill lid (A).
- 2) Check that all burner control knobs are in the off  position. Check by pushing in and turning knobs clockwise (B).
Note: It is important that all burner control knobs are in the off  position before turning on the LP tank. If they are not, the flow limiting device built into the regulator will activate, limiting the flow of gas from the LP tank.
- 3) Turn the LP tank on by slowly turning the tank valve counterclockwise; wait 60 seconds (C).
Note: It is important that the LP tank is turned on slowly. If it is opened too quickly, the flow limiting device built into the regulator will activate, limiting the flow of gas from the LP tank.
- 4) Begin with the burner furthest to the left. Push the burner control knob in and turn it counterclockwise to the start/high  position (D).
- 5) Push and hold the electronic ignition button (E). You will hear it ticking.
- 6) Check that the burner is lit by looking through the cooking grates and through the half-circle cutout in the Flavorizer™ bar.
- 7) If the burner does not ignite, turn burner control knob to the off  position and wait five minutes to allow the gas to clear before attempting to light the burner again.
- 8) If the burner ignites, repeat steps 4 through 6 to light the remaining burners.

Should the burners fail to ignite using the electronic ignition, refer to the TROUBLESHOOTING section. There you will find instructions on igniting the grill with a match to help determine the exact problem.

To Extinguish Burners

- 1) Push each burner control knob in and then turn clockwise all the way to the off  position.
- 2) Turn gas supply off at the LP tank.

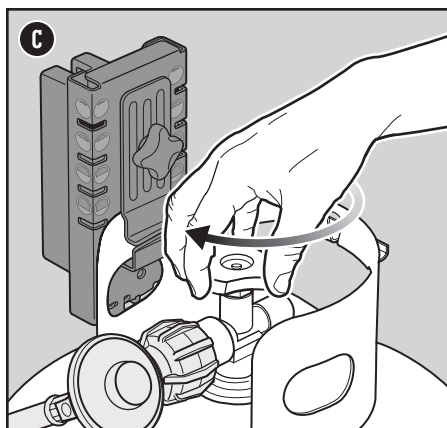
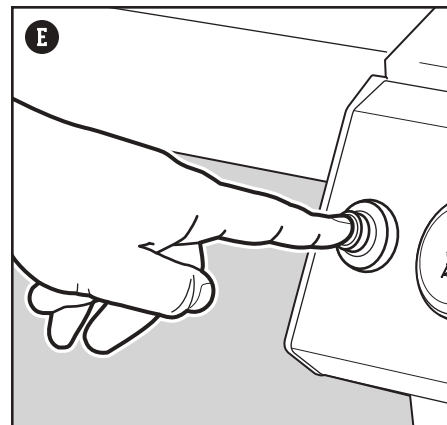
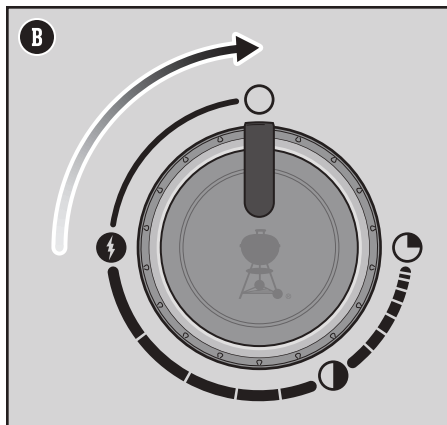
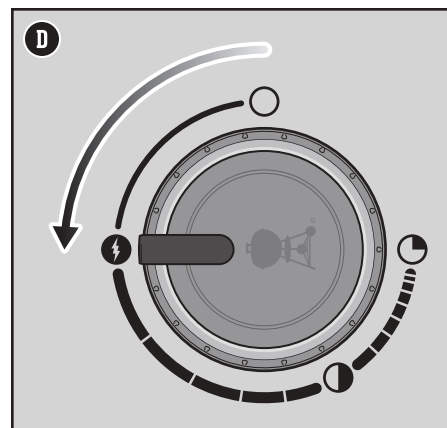
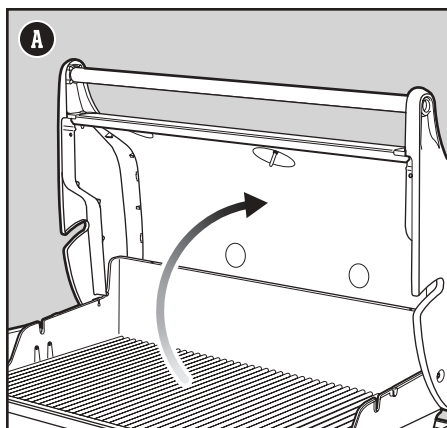

- ⚠ **WARNING:** Open lid during ignition.
- ⚠ **WARNING:** Do not lean over open grill while igniting or cooking.
- ⚠ **WARNING:** Each burner must be ignited individually by pushing the electronic ignition button.
- ⚠ **WARNING:** If ignition does not occur within four seconds of attempting to light the first burner, turn the burner control knob to the off position. Wait five minutes to allow accumulated gas to dissipate, and then repeat the lighting procedure.



FOIL PANS

Perfect for lining the catch pan to make cleanup convenient and easy.

MUST-HAVE GRILLING TOOLS • MUST-HAVE GRILLING TOOLS • MUST-HAVE GRILLING TOOLS • MUST-HAVE GRILLING TOOLS • MUST-HAVE GRILLING TOOLS • MUST-HAVE GRILLING TOOLS • MUST-HAVE GRILLING TOOLS • MUST-HAVE GRILLING TOOLS • MUST-HAVE GRILLING TOOLS • MUST-HAVE GRILLING TOOLS



BARBECUE MITTS

When in doubt, wear them. The good ones are insulated and protect both hand and forearm.

MUST-HAVE GRILLING TOOLS • MUST-HAVE GRILLING TOOLS • MUST-HAVE GRILLING TOOLS • MUST-HAVE GRILLING TOOLS • MUST-HAVE GRILLING TOOLS • MUST-HAVE GRILLING TOOLS • MUST-HAVE GRILLING TOOLS • MUST-HAVE GRILLING TOOLS • MUST-HAVE GRILLING TOOLS • MUST-HAVE GRILLING TOOLS

Cleaning and Maintenance

Cleaning the Inside of the Grill

Over time, the performance of your grill can diminish if it has not been maintained properly. Low temperatures, uneven heat, and food sticking to cooking grates are all signs that cleaning and maintenance are overdue. When your grill is off and cool, start by cleaning the inside, from the top down. A thorough cleaning is recommended at least twice a year. Consistent use may warrant quarterly cleanings.

Cleaning the Lid

From time to time you may notice "paint-like" flakes on the inside of the lid. During use, grease and smoke vapors slowly change into carbon and deposit on the inside of your lid. These deposits will eventually peel, and look very similar to paint. These deposits are non-toxic, but the flakes could fall onto your food if you do not clean the lid regularly.

- 1) Brush the carbonized grease from the inside of the lid with a stainless steel bristle grill brush (A). To minimize further build-up, the inside of the lid can be wiped with a paper towel after grilling while the grill is still warm (not hot).

Cleaning the Cooking Grates

If you have been cleaning your cooking grates as recommended, the debris on your grates should be minimal.

- 1) With grates installed, brush the debris off your cooking grate with a stainless steel bristle grill brush (B).
- 2) Take the grates out and set aside.

Cleaning the Flavorizer™ Bars

Flavorizer™ bars catch drippings that smoke and sizzle, adding flavor to your food. Any drippings that are not vaporized by the Flavorizer™ bars are funneled away from the burners. This helps prevent flare-ups inside of your grill, and protects the burners from getting clogged.

- 1) Scrape the Flavorizer™ bars with a plastic scraper (C).
- 2) If necessary, brush the Flavorizer™ bars with a stainless steel bristle grill brush.
- 3) Remove Flavorizer™ bars and set aside.

Cleaning the Burners

Two areas on the burners that are key to optimum performance are the ports (small raised openings running along the length of the burners) and the spider/insect screens on the ends of the burner. Keeping these areas clean is essential for safe operation.

Cleaning the Burner Ports

- 1) Use a clean stainless steel bristle grill brush to clean the outside of the burners by brushing across the top of the burner ports (D).
- 2) When cleaning the burners, avoid damaging the ignition electrode by carefully brushing around it (E).

Cleaning the Spider Screens

- 1) Locate the ends of the burners on the underside of the control panel where they meet the valves.
- 2) Clean the spider/insect screens on each of the burners using a soft bristle brush (F).

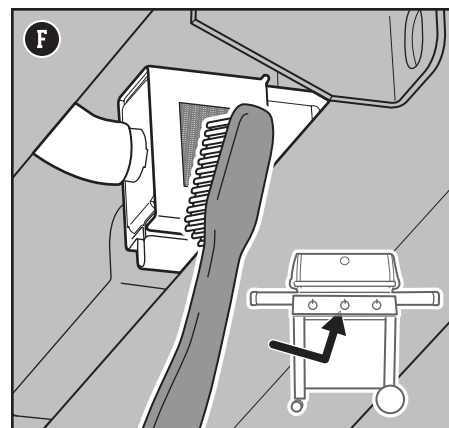
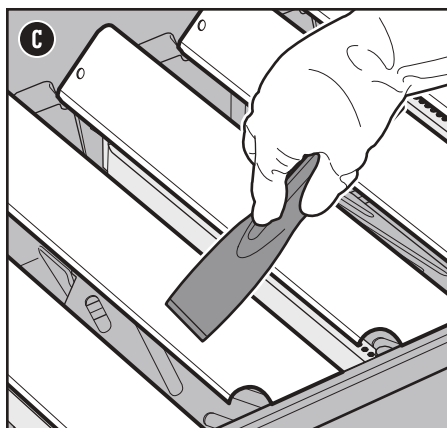
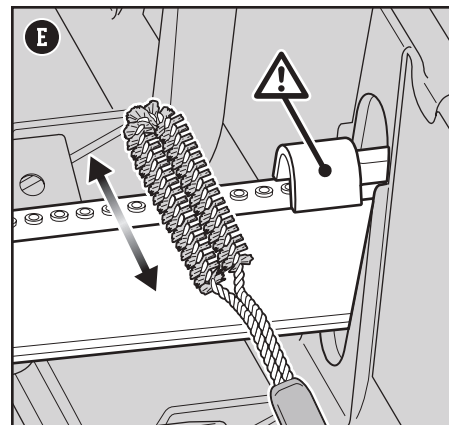
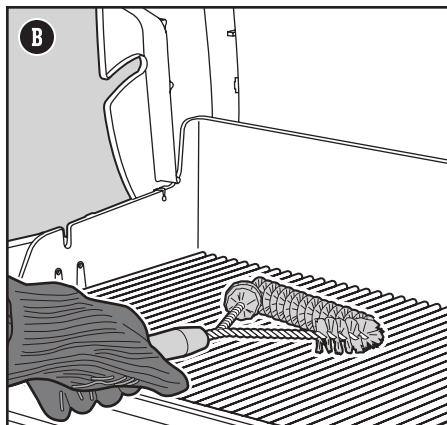
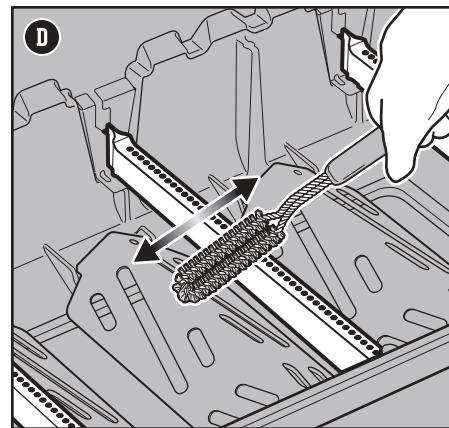
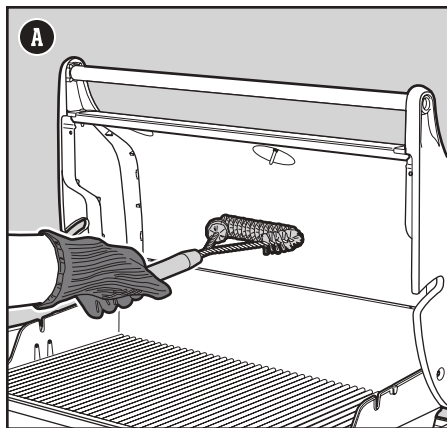

⚠ **WARNING:** Turn your grill off and wait for it to cool before thoroughly cleaning.

⚠ **WARNING:** Over time, the development of rough surfaces can form on the Flavorizer™ bars. Wearing gloves is recommended when handling. Do not clean Flavorizer™ bars or cooking grates in a sink, dishwasher, or self-cleaning oven.

⚠ **WARNING:** When cleaning the burners, never use a brush that has already been used to clean the cooking grates. Never put sharp objects into the burner port holes.

⚠ **CAUTION:** Do not place any grill components onto the side tables as they may scratch the paint or stainless steel surfaces.

⚠ **CAUTION:** Do not use any of the following to clean your grill: abrasive stainless steel polishes or paints, cleaners that contain acid, mineral spirits or xylene, oven cleaner, abrasive cleansers (kitchen cleansers), or abrasive cleaning pads.



Cleaning the Heat Deflectors

Located under the burners, the heat deflectors distribute heat evenly throughout the cookbox while cooking. Keeping heat deflectors clean will enhance the cooking performance of your grill.

- 1) Scrape the heat deflectors with a plastic scraper (G).
- 2) If necessary, brush the heat deflectors with a stainless steel bristle grill brush.
- 3) Remove heat deflectors and set aside.

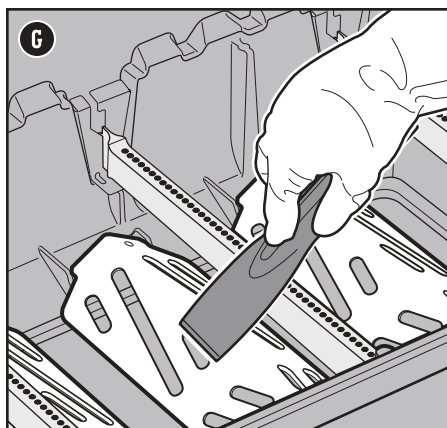

Cleaning the Cookbox

Look inside the cookbox for any grease accumulation or leftover food particles. Excessive accumulation can cause a fire.

- 1) Use a plastic scraper to scrape debris off the sides and bottom of the grill into the opening in bottom of the cookbox (H). This opening leads debris into the slide-out grease tray.

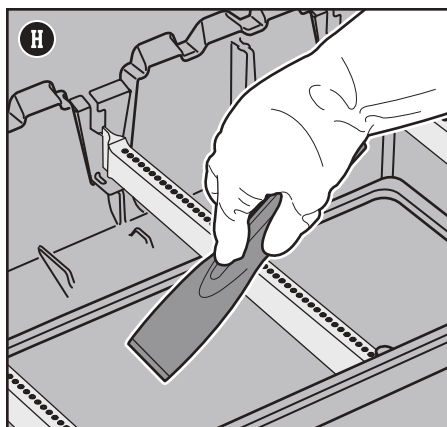

Cleaning the Grease Management System

The grease management system consists of an angled slide-out grease tray and a catch pan. These components were designed to be easily removed, cleaned, and replaced; an essential step every time you prepare to grill. Instructions on inspecting the grease management system can be found in MEAL-TO-MEAL MAINTENANCE.

Cleaning the Outside of the Grill

The outside of your grill may include stainless steel, porcelain-enameled, and plastic surfaces. Weber recommends the following methods based on the surface type.

Cleaning Stainless Steel Surfaces

Clean stainless steel using a non-toxic, non-abrasive stainless steel cleaner or polish designed for use on outdoor products and grills. Use a microfiber cloth to clean in the direction of the grain of the stainless steel. Do not use paper towels.

Note: Do not risk scratching your stainless steel with abrasive pastes. Pastes do not clean or polish. They will change the color of the metal by removing the top chromium oxide film coating.

Cleaning Painted, Porcelain-Enameled Surfaces and Plastic Components

Clean painted, porcelain-enameled and plastic components with warm soapy water, and paper towels or cloth. After wiping down the surfaces, rinse and dry thoroughly.

Cleaning the Outside of Grills that are in Unique Environments

If your grill is subject to a particularly harsh environment, you will want to clean the outside more often. Acid rain, pool chemicals, and salt water can cause surface rusting to appear. Wipe down the outside of your grill with warm soapy water. Follow up with a rinse and thorough drying. Additionally, you may want to apply a stainless steel cleaner weekly to prevent surface rust.

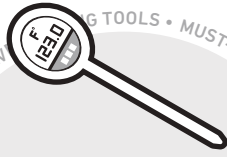

THERMOMETER

Small and relatively inexpensive, this gadget is essential for quickly gauging the internal temperature of the meat when grilling.



GRILL BRUSH

A must-use before you even dream of grilling. A quick once-over on hot grates prevents the charred remains of meals past from sticking to your meals present.

MUST-HAVE GRILLING TOOLS • MUST-HAVE GRILLING TOOLS • MUST-HAVE GRILLING TOOLS • MUST-HAVE GRILLING TOOLS • MUST-HAVE GRILLING TOOLS • MUST-HAVE GRILLING TOOLS • MUST-HAVE GRILLING TOOLS • MUST-HAVE GRILLING TOOLS • MUST-HAVE GRILLING TOOLS • MUST-HAVE GRILLING TOOLS

GRILL WILL NOT IGNITE

SYMPTOM

• Burner does not ignite when following the electronic ignition instructions in the “Operation” section of this Owner’s Manual.

CAUSE	SOLUTION
There is a problem with gas flow.	If the grill will not ignite, the first step is to determine if there is gas flowing to the burners. To check this, follow the instructions below for “Using a Match to Determine if there is Gas Flow to the Burners.” If match lighting IS NOT successful , follow the gas flow troubleshooting suggestions on the next page.
There is a problem with the electronic ignition system.	If the grill will not ignite, the first step is to determine if there is gas flowing to the burners. To check this, follow the instructions below for “Using a Match to Determine if there is Gas Flow to the Burners.” If match lighting IS successful , follow the instructions below for “Checking the Components of the Electronic Ignition System.”

Using a Match to Determine if there is Gas Flow to the Burners

- 1) Open the grill lid.
- 2) Check that all burner control knobs are in the off \bigcirc position. Check by pushing in and turning knobs clockwise.
Note: It is important that all burner control knobs be in the off \bigcirc position before you turn on the LP tank. If they are not, the flow limiting device built into the regulator will activate, limiting the flow of gas from the LP tank.
- 3) Turn the LP tank on by slowly turning the tank valve counterclockwise; wait 60 seconds.
Note: It is important that the LP tank is turned on slowly. If it is opened too quickly, the flow limiting device built into the regulator will activate, limiting the flow of gas from the LP tank.
- 4) Begin with the burner furthest to the left. Put match in the matchstick holder and strike match. (Matchstick holder is located under right side table.) Insert lit match down through the cooking grates, past the Flavorizer™ bars and next to the burner (A).
- 5) Push the burner control knob in and turn it counterclockwise to the start/high \bullet position.
- 6) Check that the burner is lit by looking through the cooking grates and through the half-circle cutout in the Flavorizer™ bar.
- 7) If the burner does not ignite within 4 seconds, turn burner control knob to the off \bigcirc position and wait five minutes to allow the gas to clear before attempting to light the burner again. If repeated attempts fail, follow the gas flow troubleshooting instructions on the next page.
- 8) If the burner ignites, the problem lies in the ignition system. Follow the instructions for “Checking the Components of the Electronic Ignition System.”
- 9) Replace the matchstick holder by hanging underneath right side table (B).

Checking the Components of the Electronic Ignition System

When pressing the ignition button you should hear a ticking sound. If you cannot hear the ticking sound, check the battery, then check the wires.

Checking the Battery

There are three potential issues with the battery that supplies the power to your ignition module that need to be checked:

- 1) Some batteries have a plastic protective wrap around them. (Do not confuse this plastic with the battery label.) Check that this plastic wrap is removed.
- 2) Confirm that the battery is installed correctly (C).
- 3) If the battery is old, replace it with a new battery.

Checking the Wires

There are two potential trouble spots that need to be checked:

- 1) Check that the ignition wires are connected securely to the terminals on the ignition button under the control panel.
- 2) Make sure the ignition wires are properly attached to the ignition module. The wire terminals are colour coded to correspond with the terminals on the ignition module. The number of wires will vary per model. Refer to Assembly Manual for details on correct wire installation.

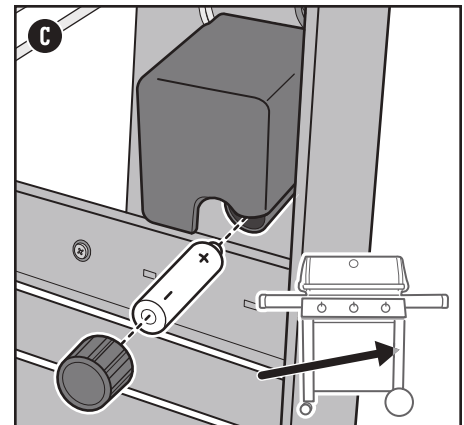
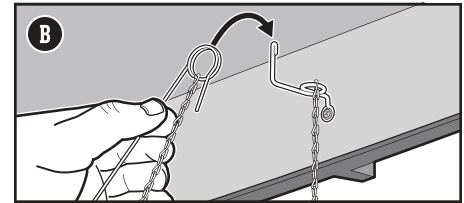
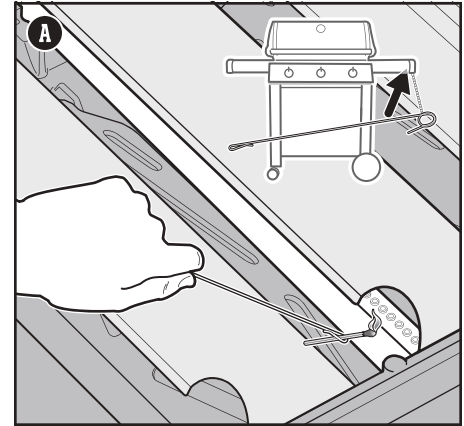

CALL CUSTOMER SERVICE

If you are still experiencing any problems, contact the Customer Service Representative in your area using the contact information on weber.com.

REPLACEMENT PARTS

To obtain replacement parts, contact the local retailer in your area or log onto weber.com.

GAS FLOW

SYMPTOM

- Grill does not reach desired temperature or heats unevenly.
- One or more of the burners fail to ignite.
- Flame is low when burner is on high position.
- Flames do not run the whole length of the burner.
- Burner flame pattern is erratic.

CAUSE

The "flow limiting device" has been activated. This safety feature built into the regulator restricts the gas flow in the event of a gas leak. You can inadvertently activate this safety feature without having a gas leak. This typically occurs when you turn on the gas at the LP tank and one or more of the control knobs are not in the off position. It may also occur if you turn on the LP tank too quickly.

SOLUTION

Reset the "flow limiting device" by closing the LP tank valve and turning all the burner control knobs to the off \bigcirc position. Wait five minutes to allow accumulated gas to dissipate, then ignite the grill again following the instructions in the "Operation" section.

The LP tank is low or empty.

Refill LP tank.

Fuel hose is bent or kinked.

Straighten fuel hose.

Burner ports are dirty.

Clean burner ports. Refer to "Cleaning the Burner Ports."

SYMPTOM

- Gas is smelled in conjunction with burner flames that appear yellow and lazy.

CAUSE

Spider screens on the burners are obstructed.

SOLUTION

Clean spider screens. Refer to "Cleaning the Spider Screens" in the Product Care section. Also refer to the illustrations and information in this section about proper flame pattern and spider screens.

SYMPTOM

- The smell of gas and/or a light hissing sound.

CAUSE

The internal rubber seal in the LP tank valve could be damaged.

SOLUTION

Inspect the rubber seal for damage. If damaged, return tank to local retailer.

GREASY GRILL (Peeling Paint & Flare-Ups)

SYMPTOM

- Inside of lid appears to have the appearance of peeling paint.

CAUSE

The flakes you see are accumulated cooking vapors that have turned into carbon.

SOLUTION

This happens over time after repeated use of your grill. This is not a defect. Clean the lid. Refer to the "Product Care" section.

SYMPTOM

- Experiencing flare-ups when grilling or preheating.

CAUSE

There is leftover food from the previous meal.

SOLUTION

Always preheat the grill with all burners on start/high position for 10 to 15 minutes.

The inside of the grill needs to be cleaned thoroughly.

Follow the steps in the "Cleaning and Maintenance" section to clean the grill inside from the top down.

Proper Burner Flame Pattern

The burners in your grill were factory set for the correct air and gas mixture. When the burners are performing correctly, you will see a specific flame pattern. The tips may occasionally flicker yellow (A), with a descending light blue (B) to dark blue flame (C).

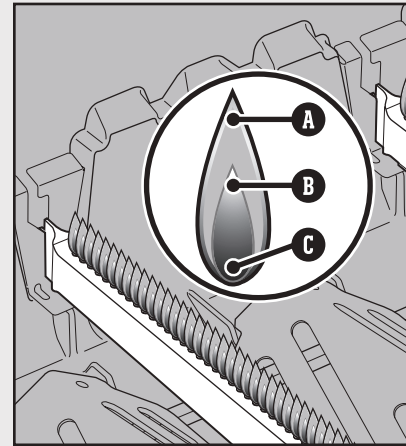

Spider Screens



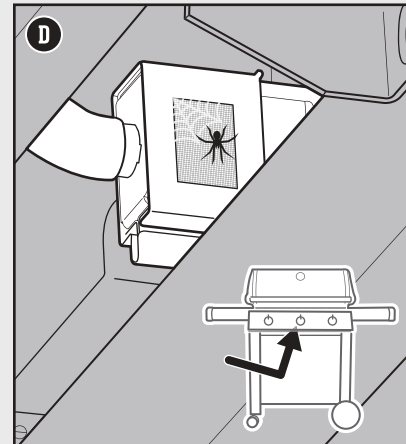

The combustion air openings of the burners (D) are fitted with stainless steel screens to prevent spiders and other insects from spinning webs and building nests inside the burners. Additionally, dust and debris can accumulate on the outside of the spider/insect screen and obstruct the oxygen flow to the burners.



⚠ WARNING: Do not attempt to make any repair to gas carrying, gas burning, ignition components or structural components without contacting Weber-Stephen Products LLC, Customer Service Department.

⚠ WARNING: Failure to use genuine Weber-Stephen parts for any repair or replacement will void all warranty protection.

Grilling Guide

Type	Thickness/Weight	Approximate Total Grill Time
 RED MEAT		
Steak: New York strip, porterhouse, rib-eye, T-bone, and filet mignon (tenderloin)	¾ inch thick	4 to 6 minutes direct high heat
	1 inch thick	6 to 8 minutes direct high heat
	2 inches thick	14 to 18 minutes sear 6 to 8 minutes direct high heat, then 8 to 10 minutes indirect high heat
Flank Steak	1½ to 2 pounds, ¾ inch thick	8 to 10 minutes direct medium heat
Ground Beef Patty	¾ inch thick	8 to 10 minutes direct medium heat
Tenderloin	3 to 4 pounds	45 to 60 minutes 15 minutes direct medium heat, then 30 to 45 minutes indirect medium heat
 PORK		
Bratwurst: fresh	3 ounce link	20 to 25 minutes direct low heat
	¾ inch thick	6 to 8 minutes direct high heat
Chop: boneless or bone in	1¼ to 1½ inches thick	10 to 12 minutes sear 6 minutes direct high heat, then 4 to 6 minutes indirect high heat
Ribs: baby back, spareribs	3 to 4 pounds	1½ to 2 hours indirect medium heat
Ribs: country-style, bone in	3 to 4 pounds	1½ to 2 hours indirect medium heat
Tenderloin	1 pound	30 minutes sear 5 minutes direct high heat, then 25 minutes indirect medium heat
 POULTRY		
Chicken Breast: boneless, skinless	6 to 8 ounces	8 to 12 minutes direct medium heat
Chicken Thigh: boneless, skinless	4 ounces	8 to 10 minutes direct medium heat
Chicken Pieces: bone in, assorted	3 to 6 ounces	36 to 40 minutes 6 to 10 minutes direct low heat, then 30 minutes indirect medium heat
Chicken: whole	4 to 5 pounds	1 to 1¼ hours indirect medium heat
Cornish Game Hen	1½ to 2 pounds	60 to 70 minutes indirect medium heat
Turkey: whole, unstuffed	10 to 12 pounds	2 to 2½ hours indirect medium heat
 SEAFOOD		
Fish, Fillet, or Steak: halibut, red snapper, salmon, sea bass, swordfish, and tuna	¼ to ½ inch thick	3 to 5 minutes direct medium heat
	1 to 1¼ inches thick	10 to 12 minutes direct medium heat
Fish: whole	1 pound	15 to 20 minutes indirect medium heat
	3 pounds	30 to 45 minutes indirect medium heat
Shrimp	1½ ounces	2 to 4 minutes direct high heat
 VEGETABLES		
Asparagus	½ inch diameter	6 to 8 minutes direct medium heat
	in husk	25 to 30 minutes direct medium heat
Corn	husked	10 to 15 minutes direct medium heat
Mushroom	shiitake or button	8 to 10 minutes direct medium heat
	portobello	10 to 15 minutes direct medium heat
Onion	halved	35 to 40 minutes indirect medium heat
	½ inch slices	8 to 12 minutes direct medium heat
Potato	whole	45 to 60 minutes indirect medium heat
	½ inch slices	9 to 11 minutes parboil 3 minutes, then 6 to 8 minutes direct medium heat

The cuts, thicknesses, weights, and grilling times above are meant to be guidelines. Factors such as altitude, wind, and outside temperature can affect cooking times. Two rules of thumb: Grill steaks, fish fillets, boneless chicken pieces, and vegetables using the direct method for the time given on the chart (or to the desired doneness), turning food once halfway through grilling time. Grill roasts, whole poultry, bone-in poultry pieces, whole fish, and thicker cuts using the indirect method for the time given on the chart (or until an instant-read thermometer registers the desired internal temperature). Cooking times for beef and lamb use the USDA's definition of medium doneness unless otherwise noted. Before carving, let roasts, larger cuts of meat, and thick chops and steaks rest for 5 to 10 minutes after cooking. The internal temperature of the meat will rise by 5 to 10 degrees during this time.

