

NETGEAR®

AC750 Wireless Dual Band Gigabit Router Model R6050 User Manual



June 2014
202-11385-01

350 East Plumeria Drive
San Jose, CA 95134
USA

Support

Thank you for selecting NETGEAR products.

After installing your device, locate the serial number on the label of your product and use it to register your product at <https://my.netgear.com>. You must register your product before you can use NETGEAR telephone support. NETGEAR recommends registering your product through the NETGEAR website. For product updates and web support, visit <http://support.netgear.com>.

Phone (US & Canada only): 1-888-NETGEAR.

Phone (Other Countries): Check the list of phone numbers at <http://support.netgear.com/general/contact/default.aspx>.

Compliance

For regulatory compliance information, visit <http://www.netgear.com/about/regulatory>.

See the regulatory compliance document before connecting the power supply.

Trademarks

NETGEAR, the NETGEAR logo, and Connect with Innovation are trademarks and/or registered trademarks of NETGEAR, Inc. and/or its subsidiaries in the United States and/or other countries. Information is subject to change without notice.
© NETGEAR, Inc. All rights reserved.

Contents

Chapter 1 Hardware Setup

| | |
|----------------------------|----|
| Unpack Your Router | 8 |
| Hardware Features | 9 |
| Front Panel | 9 |
| Rear Panel | 11 |
| Product Label | 12 |
| Position Your Router | 12 |
| Cable Your Router | 13 |

Chapter 2 Connect to the Network and Access the Router

| | |
|--|----|
| Connect to the Network | 16 |
| Wired Connection | 16 |
| WiFi Connection | 16 |
| Types of Logins | 17 |
| Use a Web Browser to Access the Router | 17 |
| NETGEAR genie Automatic Internet Setup | 17 |
| Log In to the Router | 18 |

Chapter 3 Specify Your Internet and WiFi Settings

| | |
|--|----|
| Use the Internet Setup Wizard | 21 |
| Manually Set Up the Internet Connection | 22 |
| Specify an Internet Connection Without a Login | 22 |
| Specify an Internet Connection That Uses a Login | 24 |
| Specify Basic WiFi Settings | 25 |
| Change the WiFi Password or Security Level | 27 |
| Control the Wireless Radio | 28 |
| Enable or Disable the Wireless Radio | 29 |
| Set Up a Wireless Schedule | 29 |

Chapter 4 Specify Network Settings

| | |
|--|----|
| View or Change WAN Settings | 32 |
| Set Up a Default DMZ Server | 33 |
| Change the MTU Size | 35 |
| Change the Router's Device Name | 36 |
| Change the LAN TCP/IP Settings | 37 |
| Specify the IP Addresses That the Router Assigns | 39 |
| Disable the DHCP Server Feature in the Router | 40 |
| Reserve LAN IP Addresses | 41 |

| | |
|--|----|
| Use the WPS Wizard for WiFi Connections | 43 |
| Specify WPS Settings | 44 |
| Use the Router as a Wireless Access Point. | 45 |
| Wireless Distribution System. | 47 |
| Set Up the Base Station | 48 |
| Set Up a Repeater | 49 |
| Set Up Dynamic DNS | 51 |
| Static Routes | 52 |
| Set Up a Static Route | 53 |
| Edit a Static Route. | 54 |
| Delete a Static Route | 55 |
| View Devices Currently on the Network | 55 |

Chapter 5 Optimize Performance

| | |
|---|----|
| Prioritize Internet Traffic with Quality of Service | 58 |
| WMM QoS for Wireless Multimedia Applications | 58 |
| Set Up QoS for Internet Access | 59 |
| Set Up Bandwidth Control. | 72 |
| Improve Network Connections with Universal Plug and Play. | 73 |

Chapter 6 Manage Your Network

| | |
|---|----|
| Update the Router Firmware | 76 |
| Change the admin Password | 77 |
| Recover the admin Password. | 77 |
| View Router Status | 79 |
| View the Internet Connection Settings | 80 |
| Display Internet Port Statistics | 80 |
| View the Internet Connection Status. | 81 |
| View Wireless Settings | 86 |
| View Guest Network Settings | 86 |
| View Logs of Web Access or Attempted Web Access | 87 |
| Manage the Configuration File | 89 |
| Back Up Settings. | 89 |
| Restore Configuration Settings. | 90 |
| Erase Configuration Settings. | 91 |
| Traffic Meter | 91 |
| Reboot the Router | 94 |
| Remote Management | 95 |
| Configure FastLane Settings | 97 |
| Enable FastLane. | 97 |
| Configure the WPS/FastLane button. | 98 |

Chapter 7 Share USB Devices Attached to the Router

| | |
|---|-----|
| USB Device Requirements | 100 |
| Access a USB Device on the Network. | 100 |
| Safely Remove a USB Device. | 102 |

| | |
|---|-----|
| View or Configure a USB Device | 103 |
| Configure the USB Storage Device and Access Settings..... | 104 |
| Configure the Available Network Folders | 105 |
| Specify Approved USB Devices | 109 |
| Access Your USB Device Remotely | 111 |
| Set Up a Network Printer | 113 |
| Common Uses of Network Sharing..... | 117 |
| Share Photos and Multimedia | 117 |
| Print High-Quality Photos from a Nonshared Printer | 118 |
| Send Large Files over the Internet | 118 |

Chapter 8 Control Access to the Internet

| | |
|---|-----|
| Set Up Parental Controls..... | 120 |
| Set Up a Guest Network..... | 122 |
| Use Keywords to Block Internet Sites..... | 123 |
| Set Up a Wireless Access List..... | 125 |
| Block Services from the Internet | 127 |
| Schedule When to Block Internet Sites and Services..... | 129 |
| Avoid Blocking on a Trusted Computer | 130 |
| Set Up Security Event Email Notifications..... | 130 |

Chapter 9 Specify Internet Port Settings

| | |
|---|-----|
| Set Up Port Forwarding to a Local Server | 134 |
| Add a Custom Port Forwarding Service..... | 135 |
| Edit a Port Forwarding Service | 136 |
| Delete a Port Forwarding Entry | 137 |
| Application Example: Make a Local Web Server Public..... | 138 |
| How the Router Implements the Port Forwarding Rule | 139 |
| Set Up Port Triggering | 139 |
| Add a Port Triggering Service | 140 |
| Enable Port Triggering | 141 |
| Application Example: Port Triggering for Internet Relay Chat..... | 142 |

Chapter 10 Troubleshooting

| | |
|--|-----|
| Forgotten Passwords..... | 145 |
| admin Password..... | 145 |
| WiFi Passwords | 145 |
| WiFi Connections..... | 146 |
| Changes Not Saved..... | 147 |
| Troubleshoot with the LEDs..... | 147 |
| Apply Power to the Router and Check the LEDs | 147 |
| All LEDs Remain Lit | 148 |
| Power LED Is Off or Blinking..... | 148 |
| Power LED Stays Amber | 148 |
| Internet LEDs Is Off | 148 |
| Cannot Log In to the Router..... | 149 |

| | |
|---|-----|
| The Router Cannot Access the Internet | 149 |
| Troubleshoot Internet Browsing | 151 |
| Troubleshoot a PPPoE Internet Connection | 151 |
| Troubleshoot Your Network Using the Ping Utility | 152 |
| Test the LAN Path to Your Router | 152 |
| Test the Path from Your Computer to a Remote Device | 153 |
| Troubleshoot IP Addresses | 154 |

Appendix A Supplemental Information

| | |
|--------------------------------|-----|
| Factory Default Settings | 156 |
| Technical Specifications | 157 |

Hardware Setup

1

If you have not already set up your new router using the installation guide that comes in the box, this chapter walks you through the hardware setup.

This chapter contains the following sections:

- *Unpack Your Router*
- *Hardware Features*
- *Position Your Router*
- *Cable Your Router*

For more information about the topics covered in this manual, visit the support website at <http://support.netgear.com>.

Firmware updates with new features and bug fixes are made available from time to time at downloadcenter.netgear.com. Some products can regularly check the site and download new firmware, or you can check for and download new firmware manually. If the features or behavior of your product does not match what is described in this guide, you might need to update your firmware.

Unpack Your Router

Open the box and remove the router, power adapter, cable, and installation guide.



Router

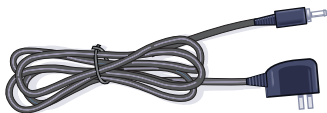

Power adapter

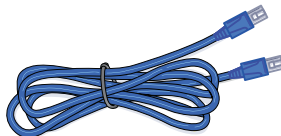

Ethernet cable

Figure 1. Package contents

Your box contains the following items:

- AC750 Wireless Dual Band Gigabit Router R6050
- AC power adapter (plug varies by region)
- Category 5 (Cat 5) Ethernet cable
- Installation guide with cabling and router setup instructions

Hardware Features

Before you cable your router, take a moment to become familiar with the label and the front and back panels. Pay particular attention to the LEDs on the front panel.

Front Panel

The router front panel has the status LEDs, buttons, and ports shown in the following figure.

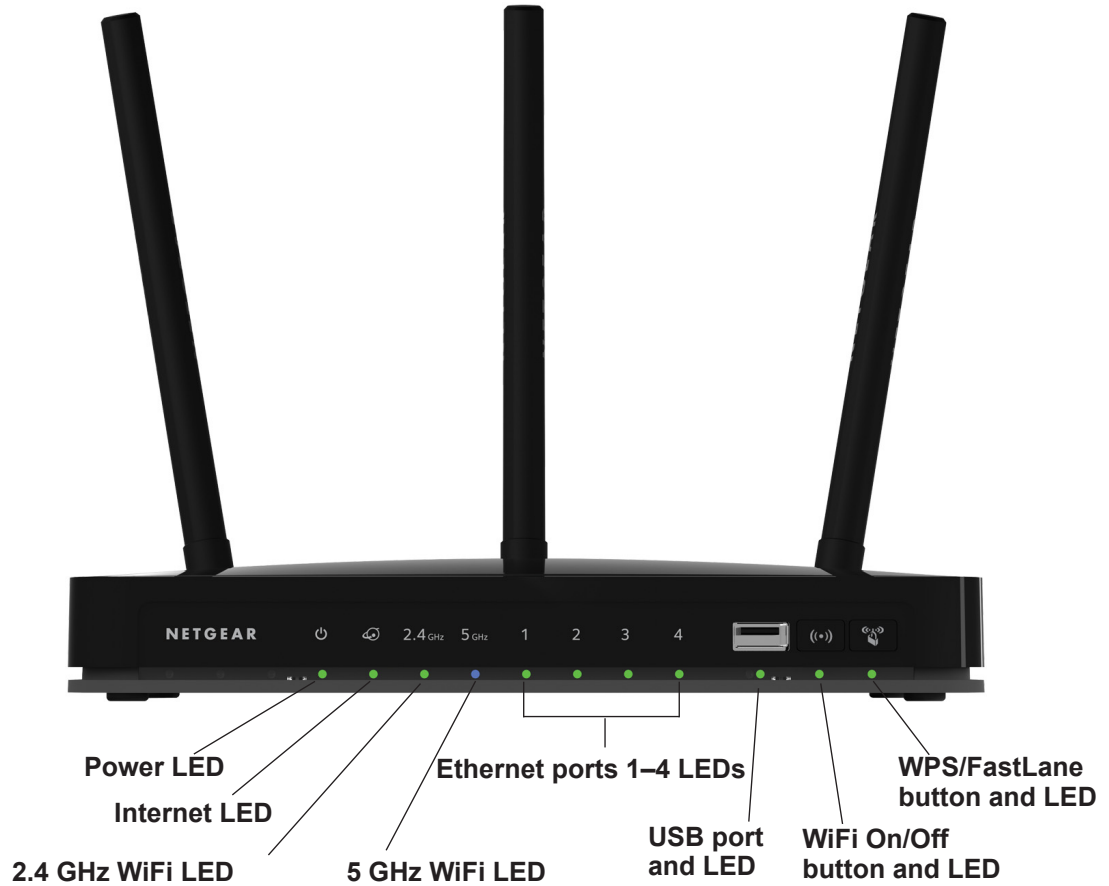











Figure 2. Front panel

Table 1. Front panel LED descriptions

| LED | Description |
|--|--|
| Power  | <ul style="list-style-type: none"> • Solid green. The startup is completed, and the router is ready. • Blinking green. The firmware is corrupted (visit http://www.netgear.com/support). • Blinking amber. The firmware is upgrading, or the Restore Factory Settings button was pressed. • Off. Power is not supplied to the router. |
| Internet  | <ul style="list-style-type: none"> • Solid green. An IP address was received; the router is ready to transmit data. • Solid amber. The router detected the Ethernet cable connection. • Off. No Ethernet cable is connected to the router. |
| 2.4 GHz WiFi  | <ul style="list-style-type: none"> • Solid green. The WiFi interface is enabled. • Blinking green. The WiFi network is communicating data. • Off. The WiFi interface is turned off. |
| 5 GHz WiFi  | <ul style="list-style-type: none"> • Solid blue. The WiFi interface is enabled. • Blinking green. The WiFi network is communicating data. • Off. The WiFi interface is turned off. |
| Ethernet ports 1–4  | <ul style="list-style-type: none"> • Solid green. The local port is connected to a 1000 Mbps device. • Blinking green. Data is being transmitted at 1000 Mbps. • Solid amber. The local port is connected to a 10/100 Mbps device. • Blinking amber. Data is being transmitted at 10/100 Mbps. • Off. No link is detected on this port. |
| USB  | <ul style="list-style-type: none"> • Solid green. The USB device is accepted by the router and is ready to be used. • Blinking green. A USB device is in use. • Off. No USB device is connected, or the Safely Remove Hardware button was clicked and it is now safe to remove the attached USB device. |
| WPS/FastLane  | <ul style="list-style-type: none"> • Solid green. A WPS-capable or FastLane-capable device is accepted by the router and is ready to be used. • Blinking green. The WPS-capable or FastLane-capable device can be associated with the router within two minutes. • Off. No WPS or FastLane connection exists. |

The WiFi On/Off and WPS/FastLane buttons toggle the WiFi and WPS functions on and off, as follows:

-  **WiFi On/Off button.** Pressing and holding this button for two seconds turns the 2.4 GHz and 5 GHz WiFi radios on and off. If the WiFi LEDs are lit, the WiFi radios are on. If the LEDs are off, the WiFi radios are turned off and you cannot connect wirelessly to the router.

-  **WPS/FastLane button.** You can use this button to use WPS or FastLane to add a WiFi device or computer to your WiFi network. The LED below the WPS/FastLane button blinks green when the router is trying to add the WiFi device or computer. The LED stays solid green when WiFi security is enabled in the router.

Rear Panel

The rear panel has the buttons and connections shown in the following figure.



Figure 3. Rear panel

Product Label

The label on the router shows the network name (SSID), network key (password), login information, MAC address, and serial number.

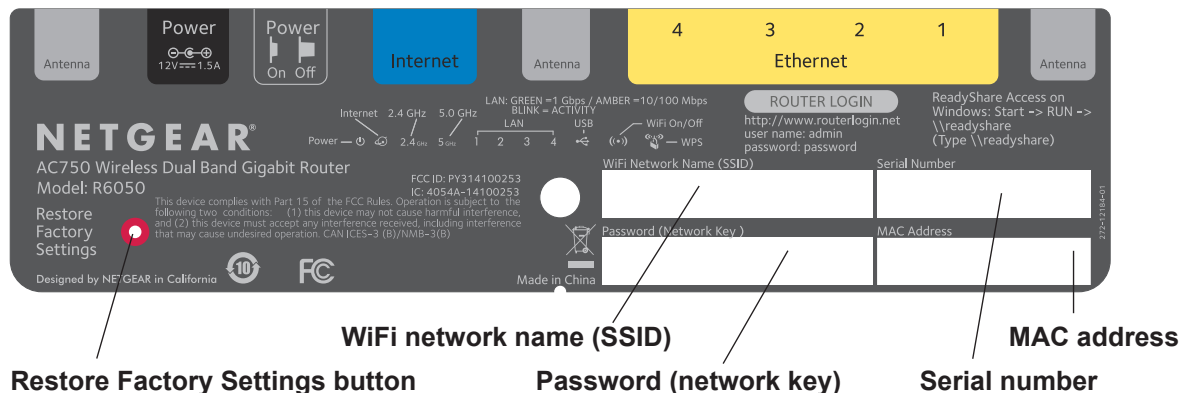

Figure 4. The label shows unique information about your router

See [Factory Default Settings](#) on page 156 for information about restoring factory settings.

Position Your Router

The router lets you access your network anywhere within the operating range of your WiFi network. However, the operating distance or range of your WiFi connection can vary significantly depending on the physical placement of your router. For example, the thickness and number of walls the WiFi signal passes through can limit the range.

Additionally, other WiFi access points in and around your home might affect your router's signal. WiFi access points are routers, repeaters, WiFi range extenders, or any other device that emits a WiFi signal for network access.

➤ To position your router:

- Carefully peel off the protective film covering your router.
- Position your router according to the following guidelines:
 - Place your router near the center of the area where your computers and other devices operate, and within line of sight to your WiFi devices.
 - Make sure that the router is within reach of an AC power outlet and near Ethernet cables for wired computers.
 - Place the router in an elevated location, minimizing the number walls and ceilings between the router and your other devices.
 - Place the router away from electrical devices such as these:
 - Ceiling fans
 - Home security systems
 - Microwaves

- Computers
- Base of a cordless phone
- 2.4 GHz cordless phone
- Place the router away from large metal surfaces, large glass surfaces, and insulated walls such as these:
 - Solid metal doors
 - Aluminum studs
 - Fish tanks
 - Mirrors
 - Brick
 - Concrete

Cable Your Router

The installation guide that came in the box has more details about installation. The following illustration shows typical cable connections for a router.

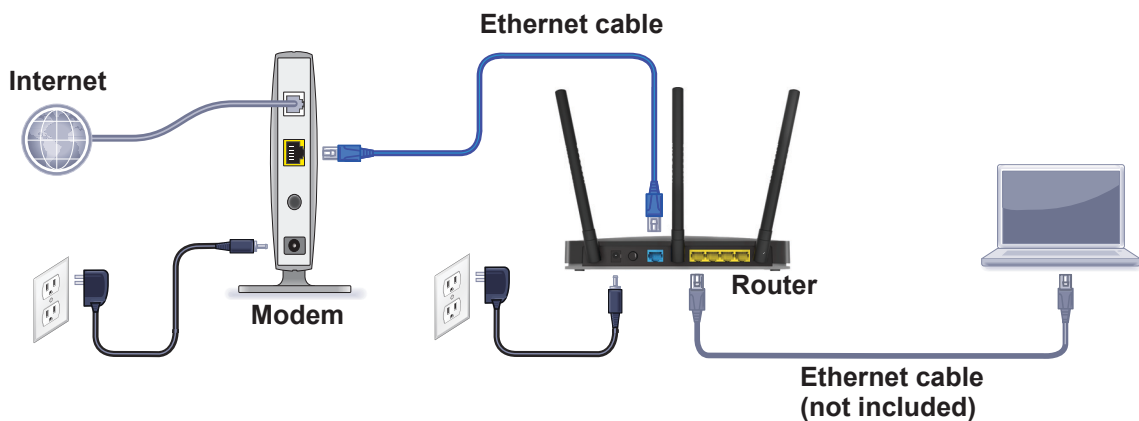

Figure 5. Router cable connections

➤ To cable your router:

1. Prepare your modem.

Unplug your modem's power. If it has a battery backup, remove the battery.

2. Connect the modem.

Plug in your modem. Put the battery back in. Then cable the modem to the router's Internet port.

3. Connect the power adapter cord that came in the package to the power input on the rear panel of the router and plug it in to an electrical outlet.

The Power LED  lights.

4. Connect a computer or WiFi device.

You have two options:

- **Connect with WiFi.** To connect with WiFi, use the WiFi network name and password on the product label.
- **Connect with an Ethernet cable.** Use an Ethernet cable to connect a computer to one of the Ethernet LAN ports on the rear panel of the router.

2

2 Connect to the Network and Access the Router

This chapter contains the following sections:

- *Connect to the Network*
- *Types of Logins*
- *Use a Web Browser to Access the Router*

Connect to the Network

You can connect to the router's network through a wired or WiFi connection. If you set up your computer to use a static IP address, change the settings so that it uses Dynamic Host Configuration Protocol (DHCP).

Wired Connection

You can connect your computer to the router using an Ethernet cable and join the router's local area network (LAN).

➤ **To connect your computer to the router with an Ethernet cable:**

1. Make sure that the router has power (its Power LED is lit).
2. Connect an Ethernet cable to an Ethernet port on your computer.
3. Connect the other end of the Ethernet cable to one of the numbered Ethernet ports.

Your computer connects to the local area network (LAN). A message might display on your computer screen to notify you that an Ethernet cable is connected.

WiFi Connection

You can connect to the router's WiFi network with Wi-Fi Protected Setup (WPS) or you can find and select the WiFi network.

➤ **To use WPS to connect to the WiFi network:**

1. Make sure that the router has power (its Power LED is lit).
2. Check the WPS instructions for your computer or WiFi device.
3. Press the **WPS/FastLane** button on the router.
4. Within two minutes, on your computer or WiFi device, press its **WPS** button or follow its instructions for WPS connections.

Your computer or WiFi device connects to the WiFi network.

➤ **To find and select the WiFi network:**

1. Make sure that the router has power (its Power LED is lit).
2. On your computer or WiFi device, find and select the WiFi network.

The WiFi network name is on the product label.

3. Join the WiFi network and enter the WiFi password.

The password is on the product label.

Your WiFi device connects to the WiFi network.

Types of Logins

Separate types of logins have different purposes. It is important that you understand the difference so that you know which login to use when.

Types of logins:

- **Internet service login.** The login that your Internet service provider (ISP) gave you logs you in to your Internet service. Your service provider gave you this login information in a letter or some other way. If you cannot find this login information, contact your service provider.
- **WiFi network login.** Your router is preset with a unique WiFi network name (SSID) and password for WiFi access. This information is on the product label.
- **Router login.** This logs you in to the router interface from the web browser as admin.

Use a Web Browser to Access the Router

When you connect to the network (either with WiFi or with an Ethernet cable), you can use a web browser to access the router to view or change its settings. The first time you access the router, NETGEAR genie automatically checks to see if your router can connect to your Internet service.

NETGEAR genie Automatic Internet Setup

You can set up your router with the NETGEAR genie automatically, or you can use the genie menus and screens to set up your router manually. Before you start the setup process, get your ISP information and make sure that the computers and devices in the network have the settings described here.

When your Internet service starts, your ISP typically gives you all the information needed to connect to the Internet. For DSL service, you might need the following information to set up your router:

- The ISP configuration information for your DSL account
- ISP login name and password
- Fixed or static IP address settings (special deployment by ISP; this setting is rare)

If you cannot locate this information, ask your ISP to provide it. When your Internet connection is working, you no longer need to launch the ISP login program on your computer to access the Internet. When you start an Internet application, your router automatically logs you in.

NETGEAR genie runs on any device with a web browser. Installation and basic setup takes about 15 minutes to complete.

➤ **To use NETGEAR genie to set up your router:**

1. Make sure that your computer or WiFi device is connected to the router with an Ethernet cable (wired) or wirelessly with the preset security settings listed on the product label.

Note: If you want to change the router's WiFi setting, use a wired connection to avoid being disconnected when the new WiFi settings take effect.

2. Launch a web browser.

The screen that displays depends on whether you have accessed the router before:

- The first time you set up the Internet connection for your router, the browser goes to <http://www.routerlogin.net>, and the NETGEAR genie screen displays.
- If you already used the NETGEAR genie, enter **<http://www.routerlogin.net>** in the address field for your browser to display the NETGEAR genie screen.

3. Follow the onscreen instructions.

NETGEAR genie guides you through connecting the router to the Internet.

4. If the browser cannot display the web page, do the following:

- Make sure that the computer is connected to one of the four LAN Ethernet ports or wirelessly to the router.
- Make sure that the router has full power, and that its Power LED is lit white.
- Close and reopen the browser or clear the browser cache.
- Browse to **<http://www.routerlogin.net>**.
- If the computer is set to a static or fixed IP address (this setting is uncommon), change it to obtain an IP address automatically from the router.

5. If the router does not connect to the Internet, do the following:

- Review your settings. Make sure that you selected the correct options and typed everything correctly.
- Contact your ISP to verify that you have the correct configuration information.
- Read *Chapter 10, Troubleshooting*. If problems persist, register your NETGEAR product and contact NETGEAR technical support.

Log In to the Router

When you first set up your router, NETGEAR genie automatically starts when you launch a web browser on a computer that is connected to the router. If you want to view or change settings for the router, you can use genie again.

➤ **To log in to the router:**

1. Launch a web browser from a computer or WiFi device that is connected to the network.
2. Enter **<http://www.routerlogin.net>** or **<http://www.routerlogin.com>**.

A login screen displays.

3. Enter the router user name and password.

The user name is **admin**. The default password is **password**. The user name and password are case-sensitive.

The BASIC Home screen displays.

Specify Your Internet and WiFi Settings

3

Usually, the quickest way to set up the router to use your Internet connection is to allow the genie to detect the Internet connection when you first access the router with a web browser. You can also customize or specify your Internet and WiFi settings.

This chapter contains the following sections:

- *Use the Internet Setup Wizard*
- *Manually Set Up the Internet Connection*
- *Specify Basic WiFi Settings*
- *Change the WiFi Password or Security Level*
- *Control the Wireless Radio*
- *Set Up a Wireless Schedule*

Use the Internet Setup Wizard

You can use the Setup Wizard to detect your Internet settings and automatically set up your router. The Setup Wizard is not the same as the genie screens that display the first time you connect to your router to set it up.

➤ **To use the Setup Wizard:**

1. Launch a web browser from a computer or WiFi device that is connected to the network.
2. Enter <http://www.routerlogin.net> or <http://www.routerlogin.com>.

A login screen displays.

3. Enter the router user name and password.

The user name is **admin**. The default password is **password**. The user name and password are case-sensitive.

The BASIC Home screen displays.

4. Select **ADVANCED > Setup Wizard**.

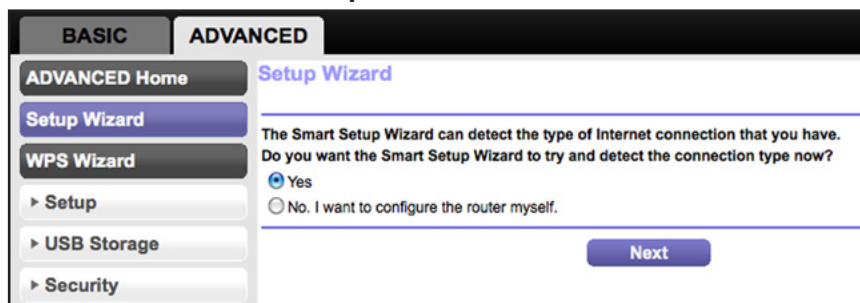

5. Select the **Yes** radio button.

If you select the **No, I want to configure the router myself** radio button, you are taken to the Internet Setup screen (see [Manually Set Up the Internet Connection](#) on page 22).

6. Click the **Next** button.

The Setup Wizard searches your Internet connection for servers and protocols to determine your ISP configuration.

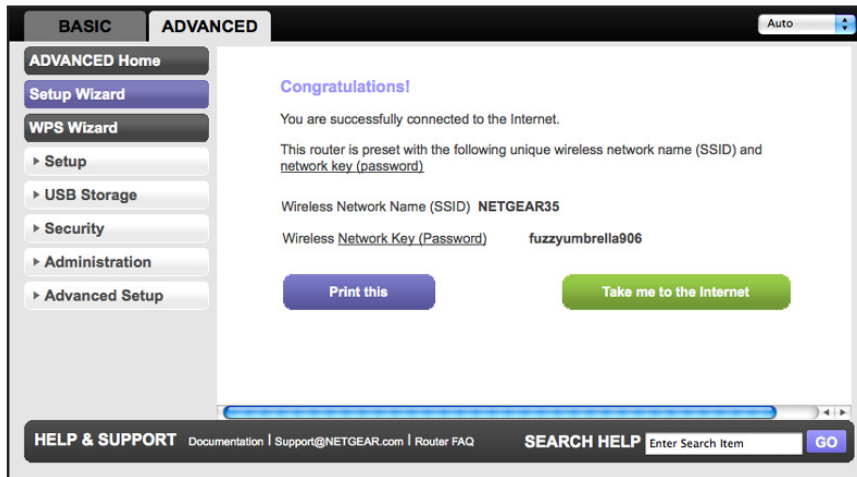

Manually Set Up the Internet Connection

You can view or change the router's Internet connection settings.

Specify an Internet Connection Without a Login

➤ **To specify the Internet connection settings:**

1. Launch a web browser from a computer or WiFi device that is connected to the network.
2. Enter <http://www.routerlogin.net> or <http://www.routerlogin.com>.

A login screen displays.

3. Enter the router user name and password.

The user name is **admin**. The default password is **password**. The user name and password are case-sensitive.

The BASIC Home screen displays.

4. Select **Internet**.

You might need to scroll to view all the settings.

5. For the Does your Internet connection require a login setting, leave the **No** radio button selected.
6. If your Internet connection requires an account name or host name, type it in the **Account Name (If Required)** field.
7. If your Internet connection requires a domain name, type it in the **Domain Name (If Required)** field.

For the other sections in this screen, the default settings usually work, but you can change them.

8. Select an Internet IP Address radio button:
 - **Get Dynamically from ISP.** Your ISP uses DHCP to assign your IP address. Your ISP automatically assigns these addresses.
 - **Use Static IP Address.** Enter the IP address, IP subnet mask, and the gateway IP address that your ISP assigned. The gateway is the ISP router to which your router connects.
9. Select a **Domain Name Server (DNS) Address** radio buttons:
 - **Get Automatically from ISP.** Your ISP uses DHCP to assign your DNS servers. Your ISP automatically assigns this address.
 - **Use These DNS Servers.** If you know that your ISP requires specific servers, select this option. Enter the IP address of your ISP's primary DNS server. If a secondary DNS server address is available, enter it also.
10. Select a **Router MAC Address** radio button:
 - **Use Default Address.** Use the default MAC address.
 - **Use Computer MAC Address.** The router captures and uses the MAC address of the computer that you are now using. You must use the one computer that the ISP allows.
 - **Use This MAC Address.** Enter the MAC address that you want to use.
11. Click the **Apply** button.
Your settings are saved.
12. Click the **Test** button to test your Internet connection.

If the NETGEAR website does not display within one minute, see [Chapter 10, Troubleshooting](#).

Specify an Internet Connection That Uses a Login

➤ To view or change the basic Internet setup:

1. Launch a web browser from a computer or WiFi device that is connected to the network.
2. Enter <http://www.routerlogin.net> or <http://www.routerlogin.com>.

A login screen displays.

3. Enter the router user name and password.

The user name is **admin**. The default password is **password**. The user name and password are case-sensitive.

The BASIC Home screen displays.

4. Select **Internet**.

← You might need to scroll to view all the settings.

5. In the Does your Internet connection require a login section of the screen, select the **Yes** radio button.

The screen adjusts.

6. In the **Internet Service Provider** list, select the encapsulation method: **PPPoE**, **L2TP**, or **PPTP**.
7. In the **Login** field, enter the login name your ISP gave you. This login name is often an email address.
8. In the **Password** field, type the password that you use to log in to your Internet service.
9. If your ISP requires a service name, type it in the **Service Name (if Required)** field.
10. In the **Connection Mode** list, select **Always On**, **Dial on Demand**, or **Manually Connect**.
11. To change the number of minutes until the Internet login times out, in the **Idle Timeout (In minutes)** field, type the number of minutes.

This is how long the router keeps the Internet connection active when no one on the network is using the Internet connection. A value of 0 (zero) means never log out.

12. Select an Internet IP Address radio button:
 - **Get Dynamically from ISP.** Your ISP uses DHCP to assign your IP address. Your ISP automatically assigns these addresses.
 - **Use Static IP Address.** Enter the IP address, IP subnet mask, and the gateway IP address that your ISP assigned. The gateway is the ISP router to which your router connects.
13. Select a Domain Name Server (DNS) Address radio button:
 - **Get Automatically from ISP.** Your ISP uses DHCP to assign your DNS servers. Your ISP automatically assigns this address.
 - **Use These DNS Servers.** If you know that your ISP requires specific servers, select this option. Enter the IP address of your ISP's primary DNS server. If a secondary DNS server address is available, enter it also.
14. Select a Router MAC Address radio button:
 - **Use Default Address.** Use the default MAC address.
 - **Use Computer MAC Address.** The router captures and uses the MAC address of the computer that you are now using. You must use the one computer that the ISP allows.
 - **Use This MAC Address.** Enter the MAC address that you want to use.
15. Click the **Apply** button.

Your settings are saved.
16. Click the **Test** button to test your Internet connection.

If the NETGEAR website does not display within one minute, see [Chapter 10, Troubleshooting](#).

Specify Basic WiFi Settings

The router comes with preset security. This means that the WiFi network name (SSID), network key (password), and security option (encryption protocol) are preset in the factory. You can find the preset SSID and password on the product label.

Note: The preset SSID and password are uniquely generated for every device to protect and maximize your WiFi security.

NETGEAR recommends that you do not change your preset security settings. If you change your preset security settings, make a note of the new settings and store it in a safe place where you can easily find it.

If you use a WiFi device to change the wireless network name (SSID) or other wireless security settings, you are disconnected when you click the **Apply** button. To avoid this problem, use a computer with a wired connection to access the router.

➤ **To specify basic WiFi settings:**

1. Launch a web browser from a computer or WiFi device that is connected to the network.
2. Enter **http://www.routerlogin.net** or **http://www.routerlogin.com**.

A login screen displays.

3. Enter the router user name and password.

The user name is **admin**. The default password is **password**. The user name and password are case-sensitive.

The BASIC Home screen displays.

4. Select **Wireless**.

The screenshot shows the router's web interface with the 'ADVANCED' tab selected. The 'Wireless' menu item is highlighted in the left sidebar. The main content area shows the 'Wireless Network' settings. Under the 'Wireless Network (2.4GHz b/g/n)' section, the 'Mode' dropdown menu is set to 'Up to 300 Mbps', with an arrow pointing to it. Other settings include 'Name (SSID): NETGEAR40', 'Channel: Auto', and 'Security Options' set to 'WPA2-PSK [AES]'. A similar section is visible for the 5GHz band.

Wireless mode settings vary by product. Some models support up to 145 Mbps maximum. See the details on the box that your router came in.

5. In the **Region** list, select your region.

In some locations, you cannot change this setting.

6. To change the network name (SSID), type a new name in the **Name (SSID)** field.

The name can be up to 32 characters long and it is case-sensitive. The default SSID is randomly generated and is on the product label. If you change the name, make sure to write down the new name and keep it in a safe place.

7. To change the wireless channel, select a number in the **Channel** list.

In some regions, not all channels are available. Do not change the channel unless you experience interference (shown by lost connections or slow data transfers). If this happens, experiment with different channels to see which is the best.

When you use multiple access points, it is better if adjacent access points use different channels to reduce interference. The recommended channel spacing between adjacent access points is four channels (for example, use Channels 1 and 5, or 6 and 10).

8. To change the mode, select it from the **Mode** list.
9. To control the SSID broadcast, select or clear the **Enable SSID Broadcast** check box.
When this check box is selected, the router broadcasts its network name (SSID) so that it displays when you scan for local WiFi networks on your computer or WiFi device.

10. Click the **Apply** button.

Your settings are saved.

If you connected wirelessly to the network and you changed the SSID, you are disconnected from the network.

Make sure that you can connect wirelessly to the network with its new settings.

If you cannot connect wirelessly, check the following:

- Is your computer or WiFi device connected to another wireless network in your area? Some wireless devices automatically connect to the first open network without wireless security that they discover.
- Is your computer or WiFi device trying to connect to your network with its old settings (before you changed the settings)? If so, update the WiFi network selection in your computer or WiFi device to match the current settings for your network.

Change the WiFi Password or Security Level

Your router comes with preset WPA2 or WPA security. The WiFi password that you enter to connect to your network is unique to your router and is on the product label. NETGEAR recommends that you use the preset security, but you can change the settings. NETGEAR recommends that you do not disable security.

➤ To change the WiFi password or security level:

1. Launch a web browser from a computer or WiFi device that is connected to the network.
2. Enter **<http://www.routerlogin.net>** or **<http://www.routerlogin.com>**.

A login screen displays.

3. Enter the router user name and password.

The user name is **admin**. The default password is **password**. The user name and password are case-sensitive.

The BASIC Home screen displays.

4. Select **Wireless**.

The screenshot shows the 'ADVANCED' settings for the 'Wireless Network' on a Netgear R6050 router. The interface is split into two main sections: 'Wireless Network (2.4GHz b/g/n)' and 'Wireless Network (5GHz a/n)'. Each section includes a text input for 'Name (SSID)', a dropdown for 'Channel', a dropdown for 'Mode', and a checked checkbox for 'Enable SSID Broadcast'. Below these are 'Security Options' with radio buttons for 'None', 'WPA2-PSK [AES]', 'WPA-PSK [TKIP] + WPA2-PSK [AES]', and 'WPA/WPA2 Enterprise'. The 'WPA-PSK [TKIP] + WPA2-PSK [AES]' option is selected. A 'Passphrase' field is present in both sections, containing the text 'dailycello500'. At the top right, there are 'Cancel' and 'Apply' buttons. A 'Help Center' link is at the bottom left, and 'Show/Hide Help Center' is at the bottom right.

5. Under **Security Options**, select a WPA option:

- WPA2-PSK [AES]
- WPA-PSK [TKIP] + WPA2-PSK [AES]
- WPA/WPA2 Enterprise

The WPA2 options use the newest standard for the strongest security, but some older computers and wireless devices cannot use WPA2. By default, the **WPA-PSK [TKIP] + WPA2-PSK [AES]** radio button is selected so that new or old computers and WiFi devices can connect to the WiFi network by using either WPA2 or WPA security.

The **Passphrase** field displays.

6. In the **Passphrase** field, enter the network key (password) that you want to use.

It is a text string from 8 to 63 characters. This is the WiFi password that you will enter in your computer or WiFi devices to connect to the network.

7. Write down the new password and keep it in a secure place for future reference.

8. Click the **Apply** button.

Your changes are saved.

Control the Wireless Radio

The router has an internal wireless radio that broadcasts signals in the 2.4 GHz range. By default, it is enabled so that you can connect wirelessly to the router. When the wireless radio is disabled, you can still use an Ethernet cable for a LAN connection to the router.

Enable or Disable the Wireless Radio

➤ To enable or disable the wireless radio:

1. Launch a web browser from a computer or WiFi device that is connected to the network.
2. Enter <http://www.routerlogin.net> or <http://www.routerlogin.com>.

A login screen displays.

3. Enter the router user name and password.

The user name is **admin**. The default password is **password**. The user name and password are case-sensitive.

The BASIC Home screen displays.

4. Select **ADVANCED > Advanced Setup > Wireless Settings**.

5. Select or clear the **Enable Wireless Router Radio** check box.

Clearing this check box turns off the WiFi feature of the router.

6. Click the **Apply** button.

Your changes are saved.

Set Up a Wireless Schedule

You can use this feature to turn off the wireless signal from your router at times when you do not need a wireless connection. For example, you might turn it off for the weekend if you leave town.

➤ To set up the wireless schedule:

1. Launch a web browser from a computer or WiFi device that is connected to the network.
2. Enter <http://www.routerlogin.net> or <http://www.routerlogin.com>.

A login screen displays.

3. Enter the router user name and password.

The user name is **admin**. The default password is **password**. The user name and password are case-sensitive.

The BASIC Home screen displays.

4. Select **ADVANCED > Advanced Setup > Wireless Settings**.

The Advanced Wireless Settings screen displays.

5. Click the **Add a new period** button.

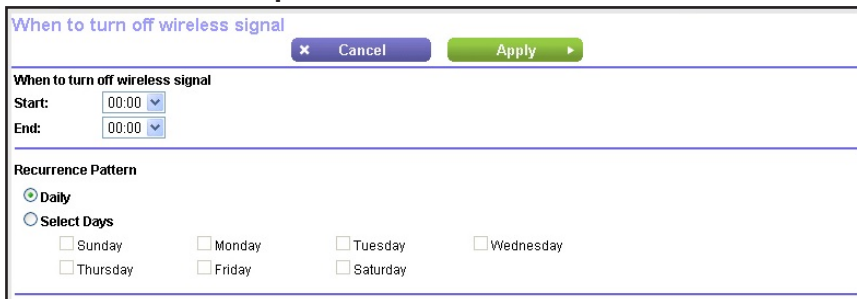

The screenshot shows a configuration window titled "When to turn off wireless signal". At the top right, there are two buttons: "Cancel" (with a close icon) and "Apply" (with a right arrow icon). Below the title bar, the "When to turn off wireless signal" section contains two dropdown menus: "Start:" and "End:", both currently set to "00:00". Below this is the "Recurrence Pattern" section, which has two radio buttons: "Daily" (which is selected) and "Select Days". Under "Select Days", there are seven checkboxes for the days of the week: Sunday, Monday, Tuesday, Wednesday, Thursday, Friday, and Saturday, all of which are currently unchecked.

6. Use the lists, radio buttons, and check boxes to set up a period during which you want to turn off the wireless signal.

7. Click the **Apply** button.

The Advanced Wireless Settings screen displays.

8. Select the **Turn off wireless signal by schedule** check box to activate the schedule.

9. Click the **Apply** button.

Your changes are saved.

Specify Network Settings

4

This chapter includes the following sections:

- *View or Change WAN Settings*
- *Set Up a Default DMZ Server*
- *Change the MTU Size*
- *Change the Router's Device Name*
- *Change the LAN TCP/IP Settings*
- *Specify the IP Addresses That the Router Assigns*
- *Disable the DHCP Server Feature in the Router*
- *Reserve LAN IP Addresses*
- *Use the WPS Wizard for WiFi Connections*
- *Specify WPS Settings*
- *Use the Router as a Wireless Access Point*
- *Wireless Distribution System*
- *Set Up Dynamic DNS*
- *Static Routes*
- *View Devices Currently on the Network*

View or Change WAN Settings

You can view or configure wide area network (WAN) settings for the Internet port. You can set up a DMZ (demilitarized zone) server, change the maximum transmit unit (MTU) size, and enable the router to respond to a ping to its WAN (Internet) port.

➤ **To view or change the WAN settings:**

1. Launch a web browser from a computer or WiFi device that is connected to the network.
2. Enter <http://www.routerlogin.net> or <http://www.routerlogin.com>.

A login screen displays.

3. Enter the router user name and password.

The user name is **admin**. The default password is **password**. The user name and password are case-sensitive.

The BASIC Home screen displays.

4. Select **ADVANCED > Setup > WAN Setup**.

The following settings display:

- **Disable Port Scan and DoS Protection.** DoS protection protects your LAN against denial of service attacks such as Syn flood, Smurf Attack, Ping of Death, and many others. Select this check box only in special circumstances.
- **Default DMZ Server.** This feature is sometimes helpful when you are playing online games or videoconferencing, but it makes the firewall security less effective. See [Set Up a Default DMZ Server](#) on page 33.
- **Respond to Ping on Internet Port.** This feature allows your router to be discovered. Use this feature only as a diagnostic tool or if you have a specific reason.
- **MTU Size (in bytes).** The normal MTU (maximum transmit unit) value for most Ethernet networks is 1500 bytes, or 1492 bytes for PPPoE connections. Change the MTU only if you are sure that it is necessary for your ISP connection. See [Change the MTU Size](#) on page 35.

- **NAT Filtering.** Network Address Translation (NAT) determines how the router processes inbound traffic:
 - Secured NAT provides a secured firewall to protect the computers on the LAN from attacks from the Internet, but might prevent some Internet games, point-to-point applications, or multimedia applications from functioning. By default, the **Secured** radio button is selected.
 - Open NAT provides a much less secured firewall, but allows almost all Internet applications to function.
 - **Disable SIP ALG.** Some Voice over IP (VoIP) applications do not function well with the Session Initiation Protocol (SIP) Application Layer Gateway (ALG). Selecting the check box to turn off the SIP ALG might enable connected VoIP devices to create and accept a VoIP call through the router. By default, this check box is cleared.
 - **Disable IGMP Proxying.** IGMP proxying allows computers on the LAN to receive the multicast traffic they are subscribed to from the Internet. By default, this check box is selected and the IGMP proxy is disabled, preventing multicast traffic from the Internet to the LAN. Clear the **Disable IGMP Proxying** check box to allow multicast traffic from the Internet to the LAN.
 - **VPN Passthrough.** The router supports VPN passthrough for IPSec, PPTP, and L2TP.
 - **IPSec Passthrough.** To enable or disable IPSec passthrough, select the **Enable** or **Disabled** radio button.
 - **PPTP Passthrough.** To enable or disable PPTP passthrough, select the **Enable** or **Disabled** radio button.
 - **L2TP Passthrough.** To enable or disable L2TP passthrough, select the **Enable** or **Disabled** radio button.
5. Change the settings as needed.
 6. Click the **Apply** button.

Your changes are saved.

Set Up a Default DMZ Server

The default DMZ server feature is helpful when you are using some online games and videoconferencing applications that are incompatible with Network Address Translation (NAT). The router is programmed to recognize some of these applications and to work correctly with them, but other applications might not function well. In some cases, one local computer can run the application correctly if the IP address for that computer is entered as the default DMZ server.

**WARNING:**

DMZ servers pose a security risk. A computer designated as the default DMZ server loses much of the protection of the firewall and is exposed to exploits from the Internet. If compromised, the DMZ server computer can be used to attack other computers on your network.

The router detects and discards incoming traffic from the Internet that is not a response to one of your local computers or a service that you have configured in the Port Forwarding/Port Triggering screen. Instead of discarding this traffic, you can have the router forward the traffic to one computer on your network. This computer is called the default DMZ server.

➤ **To set up a default DMZ server:**

1. Launch a web browser from a computer or WiFi device that is connected to the network.
2. Enter **http://www.routerlogin.net** or **http://www.routerlogin.com**.

A login screen displays.

3. Enter the router user name and password.

The user name is **admin**. The default password is **password**. The user name and password are case-sensitive.

The BASIC Home screen displays.

4. Select **ADVANCED > Setup > WAN Setup**.

5. Select the **Default DMZ Server** check box.
6. Type the IP address.
7. Click the **Apply** button.

Your settings are saved.

Change the MTU Size

The maximum transmission unit (MTU) is the largest data packet a network device transmits. When one network device communicates across the Internet with another, the data packets travel through many devices along the way. If a device in the data path has a lower MTU setting than the other devices, the data packets must be split or “fragmented” to accommodate the device with the smallest MTU.

The best MTU setting for NETGEAR equipment is often the default value. In some situations, changing the value fixes one problem but causes another. Leave the MTU unchanged unless one of these situations occurs:

- You experience problems connecting to your ISP or other Internet service, and the technical support of either the ISP or NETGEAR recommends changing the MTU setting. These web-based applications might require an MTU change:
 - A secure website that does not open, or displays only part of a web page
 - Yahoo email
 - MSN portal
 - America Online’s DSL service
- You use VPN and have severe performance problems.
- You used a program to optimize MTU for performance reasons, and now you have connectivity or performance problems.

Note: An incorrect MTU setting can cause Internet communication problems. For example, you might not be able to access certain websites, frames within websites, secure login pages, or FTP or POP servers.

➤ **To change the MTU size:**

1. Launch a web browser from a computer or WiFi device that is connected to the network.
2. Enter **<http://www.routerlogin.net>** or **<http://www.routerlogin.com>**.

A login screen displays.

3. Enter the router user name and password.

The user name is **admin**. The default password is **password**. The user name and password are case-sensitive.

The BASIC Home screen displays.

4. Select **ADVANCED** > **Setup** > **WAN Setup**.

5. In the **MTU Size** field, enter a value from 64 to 1500.

6. Click the **Apply** button.

Your change is saved.

If you suspect an MTU problem, a common solution is to change the MTU to 1400. If you are willing to experiment, you can gradually reduce the MTU from the maximum value of 1500 until the problem goes away. The following table describes common MTU sizes and applications.

Table 2. Common MTU sizes

| MTU | Application |
|------|---|
| 1500 | The largest Ethernet packet size. This setting is typical for connections that do not use PPPoE or VPN, and is the default value for NETGEAR routers, adapters, and switches. |
| 1492 | Used in PPPoE environments. |
| 1472 | Maximum size to use for ping. (Larger packets are fragmented.) |
| 1468 | Used in some DHCP environments. |
| 1460 | Usable by AOL if you do not have large email attachments, for example. |
| 1436 | Used in PPTP environments or with VPN. |
| 1400 | Maximum size for AOL DSL. |
| 576 | Typical value to connect to dial-up ISPs. |

Change the Router's Device Name

The router's device name displays in file manager when you browse your network.

➤ **To change the router's device name:**

1. Launch a web browser from a computer or WiFi device that is connected to the network.

2. Enter <http://www.routerlogin.net> or <http://www.routerlogin.com>.

A login screen displays.

3. Enter the router user name and password.

The user name is **admin**. The default password is **password**. The user name and password are case-sensitive.

The BASIC Home screen displays.

4. Select **ADVANCED > Setup > LAN Setup**.

5. In the **Device Name** field, type a new name.

6. Click the **Apply** button.

Your change is saved.

Change the LAN TCP/IP Settings

The router is preconfigured to use private IP addresses on the LAN side and to act as a DHCP server. The router's default LAN IP configuration is as follows:

- **LAN IP address.** 192.168.1.1
- **Subnet mask.** 255.255.255.0

These addresses are part of the designated private address range for use in private networks and are suitable for most applications. If your network requires a different IP addressing scheme, you can change these settings.

You might want to change these settings if you need a specific IP subnet that one or more devices on the network use, or if you have competing subnets with the same IP scheme.

➤ To change the LAN TCP/IP settings:

1. Launch a web browser from a computer or WiFi device that is connected to the network.
2. Enter <http://www.routerlogin.net> or <http://www.routerlogin.com>.

A login screen displays.

3. Enter the router user name and password.

The user name is **admin**. The default password is **password**. The user name and password are case-sensitive.

The BASIC Home screen displays.

4. Select **ADVANCED > Setup > LAN Setup**.

The screenshot shows the 'LAN Setup' configuration page. The 'Device Name' is set to 'R6050'. Under 'LAN TCP/IP Setup', the IP Address is '192.168.1.1', the IP Subnet Mask is '255.255.255.0', and the RIP Version is 'Disabled'. The 'Use Router as DHCP Server' checkbox is checked, with a starting IP of '192.168.1.2' and an ending IP of '192.168.1.254'. An 'Address Reservation' table is present with columns for #, IP Address, Device Name, and MAC Address. The 'Apply' button is highlighted in green.

5. In the **IP Address** fields, type the IP address.

6. In the **IP Subnet Mask** fields, type the subnet mask of the router.

The IP address and subnet mask identify which addresses are local to a specific device and which must be reached through a gateway or router.

7. Change the RIP settings.

Router Information Protocol (RIP) allows a router to exchange routing information with other routers.

a. In the **RIP Direction** list, select one of the following:

- **Both**. The router broadcasts its routing table periodically and incorporates information that it receives.
- **Out Only**. The router broadcasts its routing table periodically.
- **In Only**. The router incorporates the RIP information that it receives.

b. In the **RIP Version** list, select one of the following:

- **Disabled**. This is the default setting.
- **RIP-1**. This format is universally supported. It is adequate for most networks, unless you have an unusual network setup.
- **RIP-2**. This format carries more information. Both RIP-2B and RIP-2M send the routing data in RIP-2 format. RIP-2B uses subnet broadcasting. RIP-2M uses multicasting.

8. Click the **Apply** button.

Your changes are saved.

If you changed the LAN IP address of the router, you are disconnected when this change takes effect.

9. To reconnect, close your browser, relaunch it, and log in to the router.

Specify the IP Addresses That the Router Assigns

By default, the router acts as a Dynamic Host Configuration Protocol (DHCP) server. The router assigns IP, DNS server, and default gateway addresses to all computers connected to the LAN. The assigned default gateway address is the LAN address of the router.

These addresses must be part of the same IP address subnet as the router's LAN IP address. Using the default addressing scheme, define a range between 192.168.1.2 and 192.168.1.254, although you can save part of the range for devices with fixed addresses.

The router delivers the following parameters to any LAN device that requests DHCP:

- An IP address from the range that you have defined
- Subnet mask
- Gateway IP address (the router's LAN IP address)
- DNS server IP address (the router's LAN IP address)

➤ To specify the pool of IP addresses that the router assigns:

1. Launch a web browser from a computer or WiFi device that is connected to the network.
2. Enter <http://www.routerlogin.net> or <http://www.routerlogin.com>.

A login screen displays.

3. Enter the router user name and password.

The user name is **admin**. The default password is **password**. The user name and password are case-sensitive.

The BASIC Home screen displays.

4. Select **ADVANCED > Setup > LAN Setup**.

The screenshot shows the 'LAN Setup' configuration page. The 'Device Name' is 'R6050'. Under 'LAN TCP/IP Setup', the IP Address is '192.168.1.1' and the IP Subnet Mask is '255.255.255.0'. The 'RIP Direction' is set to 'Both' and 'RIP Version' is 'Disabled'. Under 'LAN DHCP Setup', the 'Use Router as DHCP Server' checkbox is checked. The 'Starting IP Address' is '192.168.1.2' and the 'Ending IP Address' is '192.168.1.254'. At the bottom, there is an 'Address Reservation' table with columns for '#', 'IP Address', 'Device Name', and 'MAC Address'. There are 'Add', 'Edit', and 'Delete' buttons for this table.

5. Make sure that the **Use Router as DHCP Server** check box is selected.
6. Specify the range of IP addresses that the router assigns:
 - a. In the **Starting IP Address** field, type the lowest number in the range.

This IP address must be in the same subnet as the router.

- b. In the **Ending IP Address** field, type the number at the end of the range of IP addresses.

This IP address must be in the same subnet as the router.

7. Click the **Apply** button.

Your settings are saved.

Disable the DHCP Server Feature in the Router

By default, the router acts as a DHCP server. The router assigns IP, DNS server, and default gateway addresses to all computers connected to the LAN. The assigned default gateway address is the LAN address of the router.

You can use another device on your network as the DHCP server, or specify the network settings of all your computers.

➤ To disable the DHCP server feature in the router:

1. Launch a web browser from a computer or WiFi device that is connected to the network.
2. Enter **http://www.routerlogin.net** or **http://www.routerlogin.com**.

A login screen displays.

3. Enter the router user name and password.

The user name is **admin**. The default password is **password**. The user name and password are case-sensitive.

The BASIC Home screen displays.

4. Select **ADVANCED > Setup > LAN Setup**.

The screenshot shows the router's configuration interface. The 'ADVANCED' tab is selected, and the 'LAN Setup' page is displayed. The 'Device Name' is 'R6050'. Under 'LAN TCP/IP Setup', the IP Address is '192.168.1.1', Subnet Mask is '255.255.255.0', RIP Direction is 'Both', and RIP Version is 'Disabled'. The 'Use Router as DHCP Server' checkbox is checked. The Starting IP Address is '192.168.1.2' and the Ending IP Address is '192.168.1.254'. There is an 'Address Reservation' table with columns for #, IP Address, Device Name, and MAC Address, and buttons for '+ Add', 'Edit', and 'Delete'.

5. Clear the **Use Router as DHCP Server** check box.
6. Click the **Apply** button.
7. (Optional) If this service is disabled and no other DHCP server is on your network, set your computer IP addresses manually so that they can access the router.

Reserve LAN IP Addresses

When you specify a reserved IP address for a computer on the LAN, that computer always receives the same IP address each time it accesses the router's DHCP server. Assign reserved IP addresses to computers or servers that require permanent IP settings.

➤ To reserve an IP address:

1. Launch a web browser from a computer or WiFi device that is connected to the network.
2. Enter <http://www.routerlogin.net> or <http://www.routerlogin.com>.

A login screen displays.

3. Enter the router user name and password.

The user name is **admin**. The default password is **password**. The user name and password are case-sensitive.

The BASIC Home screen displays.

4. Select **ADVANCED > Setup > LAN Setup**.

The screenshot shows the 'LAN Setup' page under the 'ADVANCED' tab. The 'Device Name' is 'R6050'. Under 'LAN TCP/IP Setup', the IP Address is '192.168.1.1', IP Subnet Mask is '255.255.255.0', RIP Direction is 'Both', and RIP Version is 'Disabled'. The 'Use Router as DHCP Server' checkbox is checked. The DHCP server settings show a Starting IP Address of '192.168.1.2' and an Ending IP Address of '192.168.1.254'. At the bottom, there is an 'Address Reservation' table with columns for IP Address, Device Name, and MAC Address, and buttons for '+ Add', 'Edit', and 'Delete'.

5. In the Address Reservation section of the screen, click the **Add** button.
6. In the **IP Address** field, type the IP address to assign to the computer or server.
Choose an IP address from the router's LAN subnet, such as 192.168.1.x.

7. Type the MAC address of the computer or server.

Tip: If the computer is already on your network, you can copy its MAC address from the Attached Devices screen and paste it here.

8. Click the **Apply** button.

The reserved address is entered into the table.

The reserved address is not assigned until the next time the computer contacts the router's DHCP server. Reboot the computer, or access its IP configuration and force a DHCP release and renew.

➤ **To edit a reserved address entry:**

1. Launch a web browser from a computer or WiFi device that is connected to the network.
2. Enter **http://www.routerlogin.net** or **http://www.routerlogin.com**.

A login screen displays.

3. Enter the router user name and password.

The user name is **admin**. The default password is **password**. The user name and password are case-sensitive.

The BASIC Home screen displays.

4. Select **ADVANCED > Setup > LAN Setup**.

The screenshot shows the 'LAN Setup' page in the router's web interface. The 'ADVANCED' tab is selected. The 'LAN TCP/IP Setup' section includes fields for IP Address (192.168.1.1), IP Subnet Mask (255.255.255.0), RIP Direction (Both), and RIP Version (Disabled). There is a checkbox for 'Use Router as DHCP Server' which is checked. Below this, there are fields for Starting IP Address (192.168.1.2) and Ending IP Address (192.168.1.254). The 'Address Reservation' section features a table with columns for #, IP Address, Device Name, and MAC Address, and buttons for '+ Add', 'Edit', and 'Delete'.

5. Select the radio button next to the reserved address.
6. Click the **Edit** button.
7. Change the settings.
8. Click the **Apply** button.

Your changes are saved.

➤ **To delete a reserved address entry:**

1. Launch a web browser from a computer or WiFi device that is connected to the network.
2. Enter **http://www.routerlogin.net** or **http://www.routerlogin.com**.

A login screen displays.

3. Enter the router user name and password.

The user name is **admin**. The default password is **password**. The user name and password are case-sensitive.

The BASIC Home screen displays.

4. Select **ADVANCED > Setup > LAN Setup**.

The screenshot shows the router's web interface. The top navigation bar has 'BASIC' and 'ADVANCED' tabs, with 'ADVANCED' selected. Below this is a sidebar menu with options like 'ADVANCED Home', 'Setup Wizard', 'WPS Wizard', and various setup categories. The main content area is titled 'LAN Setup' and contains several configuration sections. The 'LAN TCP/IP Setup' section includes fields for IP Address (192.168.1.1), Subnet Mask (255.255.255.0), RIP Direction (Both), and RIP Version (Disabled). There is a checkbox for 'Use Router as DHCP Server' which is checked. Below this is an 'Address Reservation' table with columns for #, IP Address, Device Name, and MAC Address. The table currently has one entry with IP 192.168.1.2. Buttons for 'Add', 'Edit', and 'Delete' are visible below the table.

5. Select the radio button next to the reserved address.

6. Click the **Delete** button.

The address is removed.

Use the WPS Wizard for WiFi Connections

The WPS Wizard helps you add a wireless computer or device to your WiFi network without typing the WiFi password.

➤ **To use the WPS Wizard:**

1. Launch a web browser from a computer or WiFi device that is connected to the network.
2. Enter <http://www.routerlogin.net> or <http://www.routerlogin.com>.

A login screen displays.

3. Enter the router user name and password.

The user name is **admin**. The default password is **password**. The user name and password are case-sensitive.

The BASIC Home screen displays.

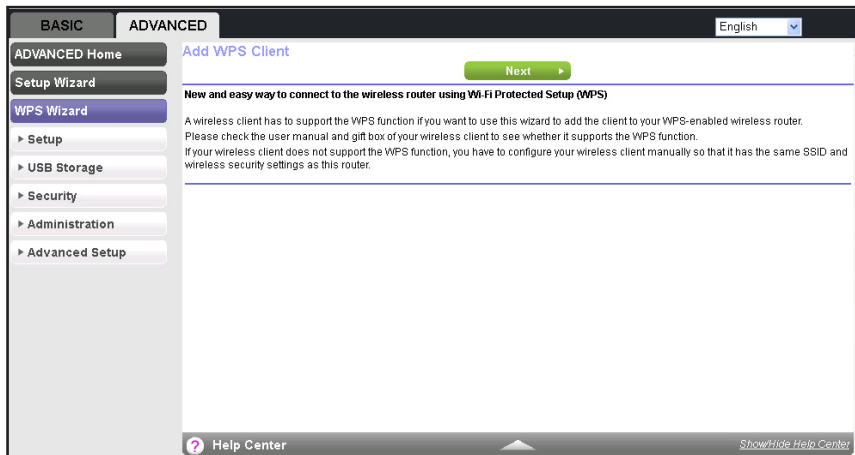
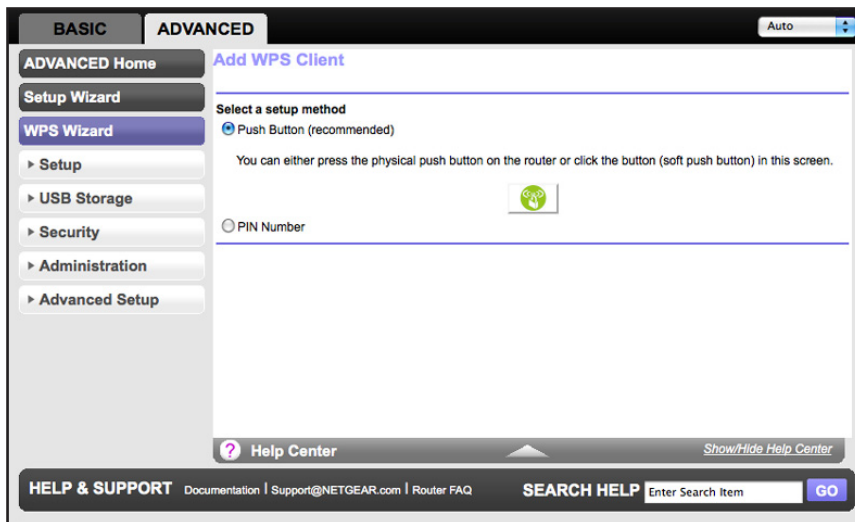
4. Select **ADVANCED** > **WPS Wizard**.5. Click the **Next** button.

6. Select the setup method that you want to use:

- **Push button.** Click the **WPS** button on this screen.
- **PIN Number.** The screen adjusts. Enter the client security PIN, and click the **Next** button.

7. Within two minutes, go to the client device and use its WPS software to connect to the WiFi network.

The WPS process automatically sets up your wireless computer with the network password when it connects. The router WPS screen displays a confirmation message.

Specify WPS Settings

Wi-Fi Protected Setup (WPS) lets you join the WiFi network without typing the WiFi password.

➤ **To specify WPS settings:**

1. Launch a web browser from a computer or WiFi device that is connected to the network.
2. Enter **http://www.routerlogin.net** or **http://www.routerlogin.com**.

A login screen displays.

3. Enter the router user name and password.

The user name is **admin**. The default password is **password**. The user name and password are case-sensitive.

The BASIC Home screen displays.

4. Select **ADVANCED > Advanced Setup > Wireless Settings**.

The **Router's PIN** field displays the PIN that you use on a registrar (for example, from the Network Explorer on a Vista Windows computer) to configure the router's wireless settings through WPS.

5. (Optional) Select or clear the **Disable Router's PIN** check box.

The PIN function might temporarily be disabled when the router detects suspicious attempts to break into the router's wireless settings by using the router's PIN through WPS. You can manually enable the PIN function by clearing the **Disable Router's PIN** check box.

6. (Optional) Select or clear the **Keep Existing Wireless Settings** check box.

By default, the **Keep Existing Wireless Settings** check box is selected. NETGEAR recommends that you leave this check box selected.

If you clear this check box, the next time a new wireless client uses WPS to connect to the router, the router wireless settings change to an automatically generated random SSID and security key.

7. Click the **Apply** button.

Your changes are saved.

Use the Router as a Wireless Access Point

The router can function in access point (AP) mode instead of regular router mode. In AP mode, the router can function as a bridge between WiFi clients and another router or gateway in your network that connects to the Internet. When the router functions in AP mode, many router functions are disabled, but WiFi clients can connect to the router. You can still access the router to change the configuration, for example, to disable AP mode and return to regular router mode.

➤ **To enable and configure AP mode:**

1. Launch a web browser from a computer or WiFi device that is connected to the network.
2. Enter **http://www.routerlogin.net** or **http://www.routerlogin.com**.

A login screen displays.

3. Enter the router user name and password.

The user name is **admin**. The default password is **password**. The user name and password are case-sensitive.

The BASIC Home screen displays.

4. Select **ADVANCED > Advanced Setup > Wireless AP**.

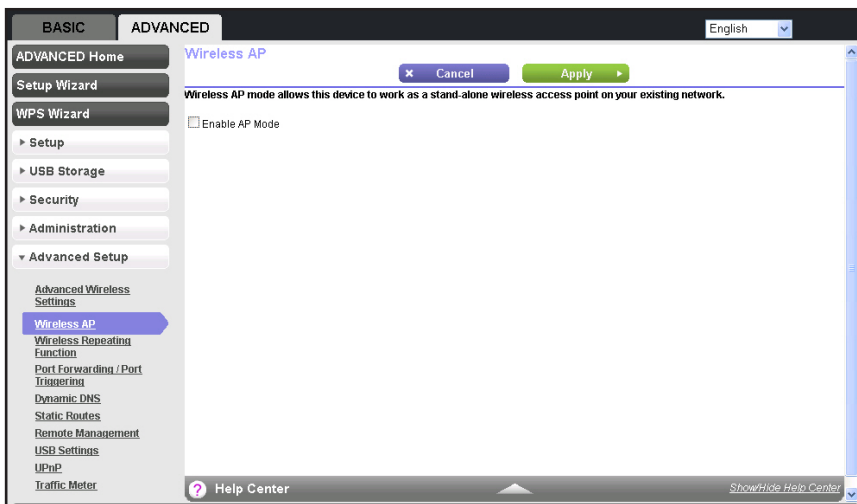

5. Select the **Enable AP Mode** check box.

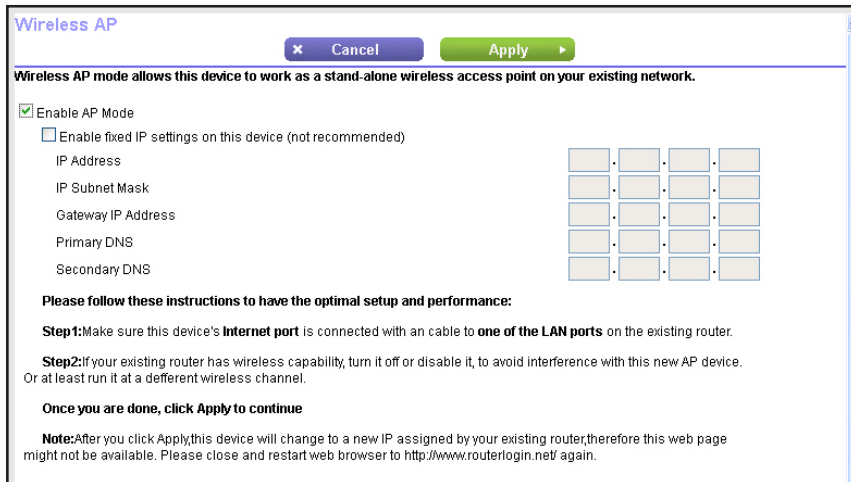

6. (Optional) Select the **Enable fixed IP settings on this device** check box.

NETGEAR recommends that you do not use this feature.

7. Enter the following information about your Internet connection:

- **IP Address.** The IP address that your ISP assigned.
- **IP Subnet Mask.** The IP subnet mask that your ISP assigned.
- **Gateway IP Address.** The gateway IP address that your ISP assigned. The gateway is the ISP's router to which your router connects.

- **Primary DNS.** The IP address of your ISP's primary DNS server.
 - **Secondary DNS.** The IP address of your ISP's secondary DNS server.
8. Click the **Apply** button.
The IP address of the router changes, and you are disconnected.
 9. To reconnect, close and restart your browser and enter **www.routerlogin.net**.

Wireless Distribution System

You can set up the router to be used as a wireless base station or wireless repeater in a wireless distribution system (WDS). A WDS lets you expand a wireless network through multiple access points instead of using a wired backbone to link them. A wireless base station connects to the Internet, can have wired and wireless clients, and sends its wireless signal to an access point that functions as a wireless repeater. A wireless repeater can also have wired and wireless clients, but connects to the Internet through the wireless base station.

The following figure shows a wireless repeating scenario.

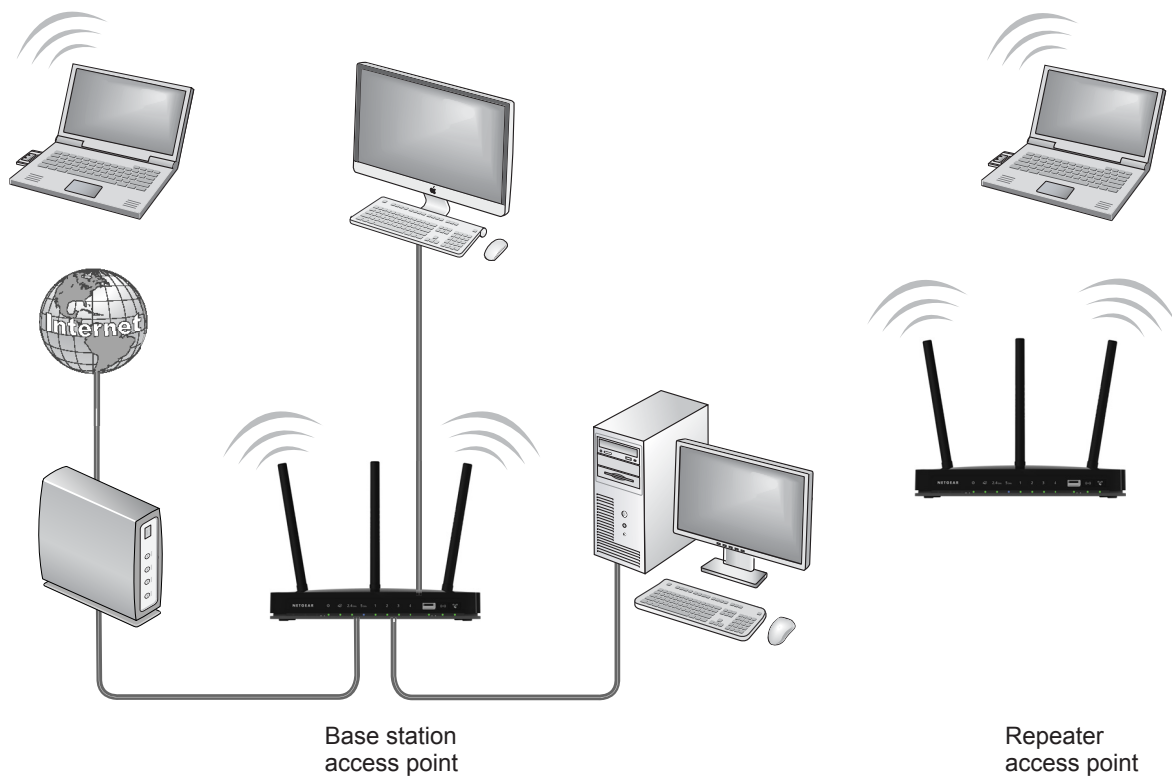

Figure 6. Wireless repeating scenario

The router can function either as a base station or as a repeater:

- **Wireless base station.** The router acts as the parent access point, bridging traffic to and from the child repeater access point, as well as handling wireless and wired local

computers. To configure this mode, you must know the MAC address of the child repeater access point.

- **Wireless repeater.** The router sends all traffic from its local wireless or wired computers to a remote access point. To configure this mode, you must know the MAC address of the remote parent access point.

For you to set up a WiFi network in a WDS, the following conditions must be met for both access points:

- Both access points must use the same SSID, wireless channel, and encryption mode.
- Both access points must be on the same LAN IP subnet. That is, all the access point LAN IP addresses are in the same network.
- All LAN devices (wired and wireless computers) must be configured to operate in the same LAN network address range as the access points.
- The channel selection on the access points cannot be **Auto** (see *Specify Basic WiFi Settings* on page 25).
- The security option must be WEP (or no security). The **WEP** option displays only if you select **Up to 54 Mbps** from the **Mode** list on the Wireless Settings screen (see *Specify Basic WiFi Settings* on page 25).

Set Up the Base Station

The wireless repeating function works only in hub and spoke mode. The units cannot be daisy-chained. You must know the wireless MAC addresses of all units. First, set up the base station and then set up the repeater.

➤ To set up the base station:

1. Launch a web browser from a computer or WiFi device that is connected to the network.
2. Enter **http://www.routerlogin.net** or **http://www.routerlogin.com**.

A login screen displays.

3. Enter the router user name and password.

The user name is **admin**. The default password is **password**. The user name and password are case-sensitive.

The BASIC Home screen displays.

4. Select **ADVANCED > Advanced Setup > Wireless Repeating Function**.

The Wireless Repeating Function screen displays. The wireless MAC address of the router displays onscreen.

5. Select the **Enable Wireless Repeating Function** check box.

6. Select the **Wireless Base Station** radio button.

7. To prevent wireless clients from associating with the base station and allow LAN client associations only, select the **Disable Wireless Client Association** check box.

You can leave the check box cleared if you prefer wireless clients to be able to associate with the base stations.

8. In the **Repeater MAC Address 1** through **4** fields, enter the MAC addresses for the access points that should function as repeaters.

If your router is the base station, it can function as the “parent” for up to four other access points.

9. Click the **Apply** button.

Your changes are saved.

Set Up a Repeater

To set up the repeater to avoid conflicts with the wireless connection to the base station, use a wired Ethernet connection.

Note: If you set up your router as a base station with a non-NETGEAR access point as the repeater, you might need to change more configuration settings. In particular, you should disable the DHCP server function on the access point that functions as the repeater.

➤ To configure the router as a repeater:

1. Launch a web browser from a computer or WiFi device that is connected to the network.
2. Enter <http://www.routerlogin.net> or <http://www.routerlogin.com>.

A login screen displays.

3. Enter the router user name and password.

The user name is **admin**. The default password is **password**. The user name and password are case-sensitive.

The BASIC Home screen displays.

4. Select **ADVANCED > Advanced Setup > Wireless Repeating Function**.

The Wireless Repeating Function screen displays. The wireless MAC address of the router displays onscreen.

5. Select the **Enable Wireless Repeating Function** check box.
6. Select the **Wireless Repeater** radio button.

7. Complete the **Repeater IP Address** field.
This IP address must be in the same subnet as the base station, but different from the LAN IP address of the base station.
8. To prevent wireless clients from associating with the repeater and allow LAN client associations only, select the **Disable Wireless Client Association** check box.
You can leave the check box cleared if you prefer wireless clients to be able to associate with the repeater.
9. In the **Base Station MAC Address** field, enter the MAC addresses for the access point that will function as the base station.
10. Click the **Apply** button.
Your changes are saved.
11. Verify connectivity across the LANs.

A computer on any wireless or wired LAN segment of the base station or a repeater can connect to the Internet. Any computer that is connected to the base station can share files and printers with any other wireless or wired computer or server that is connected to a repeater.

Set Up Dynamic DNS

If your Internet service provider (ISP) gave you a permanently assigned IP address, you can register a domain name and have that name linked with your IP address by public Domain Name Servers (DNS). However, if your Internet account uses a dynamically assigned IP address, you do not know in advance what your IP address is, and the address can change frequently. In this case, you can use a commercial Dynamic DNS service. This type of service lets you register your domain to their IP address and forwards traffic directed at your domain to your frequently changing IP address.

If your ISP assigns a private WAN IP address (such as 192.168.x.x or 10.x.x.x), the Dynamic DNS service does not work because private addresses are not routed on the Internet.

Your router contains a client that can connect to the Dynamic DNS service provided by DynDNS.org. First visit their website at <http://www.dyndns.org> and obtain an account and host name that you configure in the router. Then, whenever your ISP-assigned IP address changes, your router automatically contacts the Dynamic DNS service provider, logs in to your account, and registers your new IP address. If your host name is hostname, for example, you can reach your router at <http://hostname.dyndns.org>.

Note: Before you set up Dynamic DNS on router, first register an account with one of the Dynamic DNS service providers whose URLs display in the **Service Provider** list on the Dynamic DNS screen.

➤ **To set up Dynamic DNS:**

1. Launch a web browser from a computer or WiFi device that is connected to the network.
2. Enter <http://www.routerlogin.net> or <http://www.routerlogin.com>.

A login screen displays.

3. Enter the router user name and password.

The user name is **admin**. The default password is **password**. The user name and password are case-sensitive.

The BASIC Home screen displays.

4. Select **ADVANCED > Advanced Setup > Dynamic DNS.**

5. Select the **Use a Dynamic DNS Service** check box.
6. Select the URL of your Dynamic DNS service provider.
7. Type the host name (or domain name) that your Dynamic DNS service provider gave you.
8. Type the user name for your Dynamic DNS account.
This name is the name that you use to log in to your account, not your host name.
9. Type the password (or key) for your Dynamic DNS account.
10. Click the **Apply** button.

To verify the Dynamic DNS status, click the **Show Status** button.

Static Routes

Static routes provide routing information to your router. Under usual circumstances, the router has adequate routing information after it has been configured for Internet access, and you do not need to configure more static routes. You must configure static routes only for unusual cases such as multiple routers or multiple IP subnets on your network.

As an example of when a static route is needed, consider the following case:

- Your primary Internet access is through a cable modem to an ISP.
- You have an ISDN router on your home network for connecting to the company where you are employed. This router's address on your LAN is 192.168.1.100.
- Your company's network address is 134.177.0.0.

When you first configured your router, two implicit static routes were created. A default route was created with your ISP as the gateway, and a second static route was created to your local network for all 192.168.1.x addresses. With this configuration, if you attempt to access a device on the 134.177.0.0 network, your router forwards your request to the ISP. The ISP forwards your request to the company where you are employed, and the company's firewall denies the request.

In this case you must define a static route, telling your router that 134.177.0.0 should be accessed through the ISDN router at 192.168.1.100. This example assumes the following settings:

- The **Destination IP Address** and **IP Subnet Mask** fields specify that this static route applies to all 134.177.x.x addresses.
- The **Gateway IP Address** field specifies that all traffic for these addresses should be forwarded to the ISDN router at 192.168.1.100.
- A metric value of **1** works because the ISDN router is on the LAN.
- **Private** is selected only as a precautionary security measure in case RIP is activated.

Set Up a Static Route

➤ To set up a static route:

1. Launch a web browser from a computer or WiFi device that is connected to the network.
2. Enter <http://www.routerlogin.net> or <http://www.routerlogin.com>.

A login screen displays.

3. Enter the router user name and password.

The user name is **admin**. The default password is **password**. The user name and password are case-sensitive.

The BASIC Home screen displays.

4. Select **ADVANCED > Advanced Setup > Static Routes**.

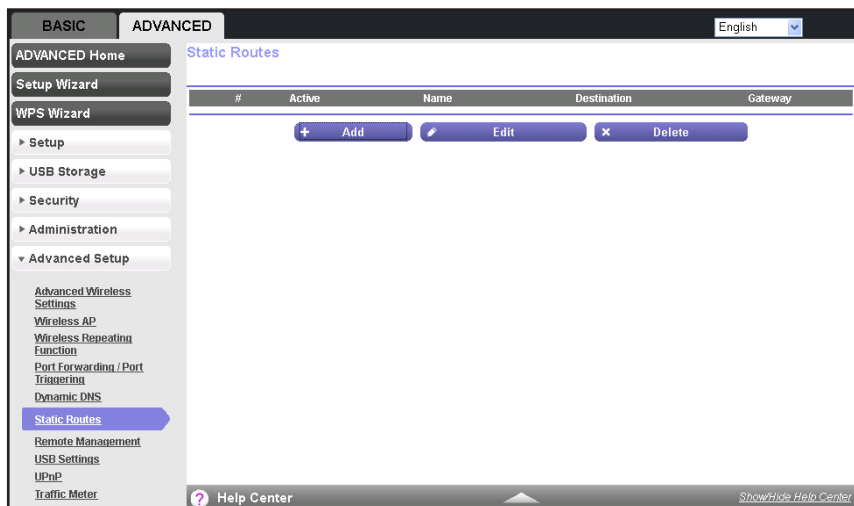

5. Click the **Add** button.

The screen adjusts:

6. In the **Route Name** field, type a name for this static route (for identification purposes only).
7. If you want to limit access to the LAN only, select the **Private** check box.
If you select **Private**, the static route is not reported in RIP.
8. To make this route effective, select the **Active** check box.
By default, the **Active** check box is selected.
9. Type the IP address of the final destination.
10. Type the IP subnet mask for this destination. If the destination is a single host, type **255.255.255.255**.
11. Type the gateway IP address, which must be a router on the same LAN segment as this router.
12. Type a number from 1 through 15 as the metric value.
This value represents the number of routers between your network and the destination. Usually, a setting of 2 or 3 works, but if this link is a direct connection, set it to **1**.
13. Click the **Apply** button.
The route is added to the table on the Static Routes screen.

Edit a Static Route

- **To edit a static route:**
 1. Launch a web browser from a computer or WiFi device that is connected to the network.
 2. Enter **http://www.routerlogin.net** or **http://www.routerlogin.com**.
A login screen displays.
 3. Enter the router user name and password.

The user name is **admin**. The default password is **password**. The user name and password are case-sensitive.

The BASIC Home screen displays.

4. Select **ADVANCED > Advanced Setup > Static Routes**.

The Static Routes screen displays.

5. In the table, select the radio button next to the route that you want to edit.

6. Click the **Edit** button.

The Static Routes screen adjusts.

7. Edit the route information.

8. Click the **Apply** button.

Your changes are saved.

Delete a Static Route

➤ **To delete a static route:**

1. Launch a web browser from a computer or WiFi device that is connected to the network.

2. Enter **http://www.routerlogin.net** or **http://www.routerlogin.com**.

A login screen displays.

3. Enter the router user name and password.

The user name is **admin**. The default password is **password**. The user name and password are case-sensitive.

The BASIC Home screen displays.

4. Select **ADVANCED > Advanced Setup > Static Routes**.

The Static Routes screen displays.

5. In the table, select the radio button next to the route that you want to delete.

6. Click the **Delete** button.

The route is removed from the table.

View Devices Currently on the Network

You can view all computers or devices that are currently connected to your network.

➤ **To view devices on the network:**

1. Launch a web browser from a computer or WiFi device that is connected to the network.

2. Enter **http://www.routerlogin.net** or **http://www.routerlogin.com**.

A login screen displays.

3. Enter the router user name and password.

The user name is **admin**. The default password is **password**. The user name and password are case-sensitive.

The BASIC Home screen displays.

4. Select **Attached Devices**.

The screenshot shows the 'Attached Devices' page in the router's web interface. The 'Wired Devices' table is as follows:

| # | IP Address | MAC Address | Device Name |
|---|------------|-------------------|-------------|
| 1 | 10.0.0.2 | 00:1B:63:A2:B7:2D | <unknown> |

The Wired Devices section lists devices that are connected to the router with Ethernet cables. The Wireless Devices section lists devices that are connected to the wireless network.

The following information is displayed:

- **# (number)**. The order in which the device joined the network.
 - **IP Address**. The IP address that the router assigned to this device when it joined the network. This number can change if a device is disconnected and rejoins the network.
 - **MAC Address**. The unique MAC address for each device does not change. The MAC address is typically shown on the product label.
 - **Device Name**. If the device name is known, it is shown here.
5. To update this screen, click the **Refresh** button.

Optimize Performance

5

This chapter includes the following sections:

- *Prioritize Internet Traffic with Quality of Service*
- *Improve Network Connections with Universal Plug and Play*

Prioritize Internet Traffic with Quality of Service

Quality of Service (QoS) is an advanced feature that can be used to prioritize some types of traffic ahead of others. The router can provide QoS prioritization over the wireless link and on the Internet connection.

WMM QoS for Wireless Multimedia Applications

The router supports Wi-Fi Multimedia Quality of Service (WMM QoS) to prioritize wireless voice and video traffic over the wireless link. WMM QoS provides prioritization of wireless data packets from different applications based on four access categories: voice, video, best effort, and background. For an application to receive the benefits of WMM QoS, both it and the client running that application must WMM enabled. Legacy applications that do not support WMM and applications that do not require QoS are assigned to the best effort category, which receives a lower priority than voice and video. WMM QoS is enabled by default.

➤ To disable WMM QoS:

1. Launch a web browser from a computer or WiFi device that is connected to the network.
2. Enter **http://routerlogin.net** or **http://192.168.0.1**.

A login screen displays.

3. Enter the router user name and password.

The user name is **admin**. The default password is **password**. The user name and password are case-sensitive.

The BASIC Home screen displays.

4. Select **ADVANCED > Setup > QoS Setup**.

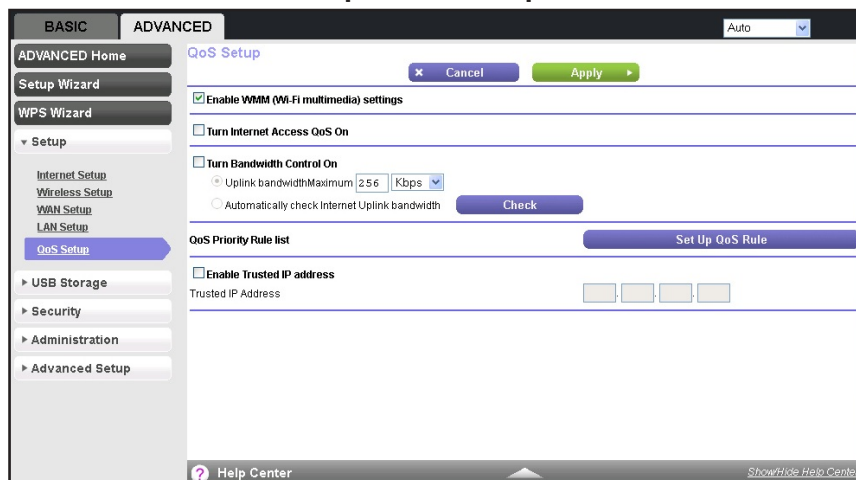

5. Clear the **Enable WMM** check box.
6. Click the **Apply** button.

Your changes are saved.

Set Up QoS for Internet Access

You can give prioritized Internet access to the following types of traffic:

- Specific applications
- Specific online games
- Individual Ethernet LAN ports of the router
- A specific device by MAC address

To specify prioritization of traffic, you need to create a policy for the type of traffic and add the policy to the QoS Policy table in the QoS Setup screen. For convenience, the QoS Policy table lists many common applications and online games that can benefit from QoS handling.

By default, QoS is disabled for Internet traffic, the default QoS rules and any custom QoS rules that you created are not activated, and no traffic is prioritized.

QoS for an Application or Online Game

➤ To create a QoS policy for an application or online game:

1. Launch a web browser from a computer or WiFi device that is connected to the network.
2. Enter **http://routerlogin.net** or **http://192.168.0.1**.

A login screen displays.

3. Enter the router user name and password.

The user name is **admin**. The default password is **password**. The user name and password are case-sensitive.

The BASIC Home screen displays.

4. Select **ADVANCED > Setup > QoS Setup**.

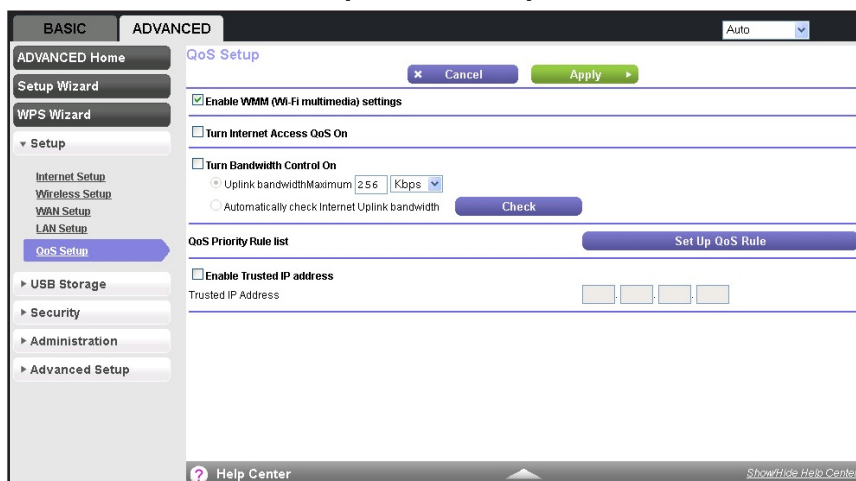

- Click the **Set Up QoS Rule** button.

QoS Priority Rule list

| # | QoS Policy | Priority | Description |
|----|-----------------|----------|------------------------------|
| 1 | MSN Messenger | High | MSN Messenger Applications |
| 2 | Yahoo Messenger | High | Yahoo Messenger Applications |
| 3 | IP Phone | Highest | IP Phone Applications |
| 4 | Vonage IP Phone | Highest | Vonage IP Phone Applications |
| 5 | NetMeeting | High | NetMeeting Applications |
| 6 | AIM | High | AIM Applications |
| 7 | Google Talk | Highest | Google Talk Applications |
| 8 | Netgear EVA | Highest | Netgear EVA Applications |
| 9 | SSH | High | SSH Applications |
| 10 | Telnet | High | Telnet Applications |
| 11 | VPN | High | VPN Applications |
| 12 | FTP | Normal | FTP Applications |
| 13 | SMTP | Normal | SMTP Applications |
| 14 | WWW | Normal | WWW Applications |
| 15 | DNS | Normal | DNS Applications |
| 16 | eMule/Donkey | Low | eMule/Donkey Applications |
| 17 | Kazaa | Low | Kazaa Applications |
| 18 | Gnutella | Low | Gnutella Applications |

Buttons: Edit, Delete, Delete All, Add Priority Rule

Help Center, Show/Hide Help Center

Scroll down

- Click the **Add Priority Rule** button.

QoS - Priority Rules

Buttons: Cancel, Apply

Priority

QoS Policy for: MSN Messenger

Priority Category: Applications

Applications: MSN Messenger

Priority: Normal

- In the **QoS Policy for** field, type a descriptive name for the new application or game.
- In the **Priority Category** list, select either **Applications** or **Online Gaming**:
 - Applications.** The **Applications** list lets you select existing applications, but scroll down to the bottom to select **Add a new application**.

QoS - Priority Rules

Buttons: Cancel, Apply

Priority

QoS Policy for:

Priority Category: Applications

Applications: Add a new application

Priority: Normal

Specified Port Range

Connection Type: TCP/UDP

Starting Port: (1-65535)

Ending Port: (1-65535)

- **Online Gaming.** The **Online Gaming** list lets you select existing games, but scroll down to the bottom to select **Add a new game**.

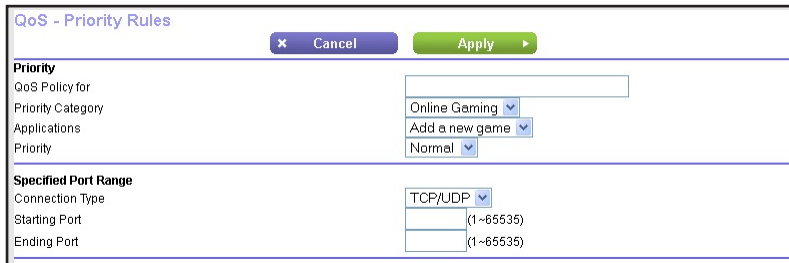

9. From the **Priority** list, select the priority that this traffic should receive relative to other applications and traffic when accessing the Internet.
The options are Low, Normal, High, and Highest.
10. In the **Connection Type** field, select either **TCP**, **UDP**, or **TCP/UDP**.
11. In the **Starting Port** and **Ending Port** fields, specify the port number or range of port numbers that the application or game uses.
12. Click the **Apply** button.

The rule is saved in the QoS Policy table.

The QoS Setup screen displays.

QoS for a Router Ethernet LAN Port

- **To create a QoS policy for a device connected to one of the router's Ethernet LAN ports:**
 1. Launch a web browser from a computer or WiFi device that is connected to the network.
 2. Enter **http://routerlogin.net** or **http://192.168.0.1**.
A login screen displays.
 3. Enter the router user name and password.
The user name is **admin**. The default password is **password**. The user name and password are case-sensitive.
The BASIC Home screen displays.

4. Select **ADVANCED** > **Setup** > **QoS Setup**.



5. Click the **Set Up QoS Rule** button.

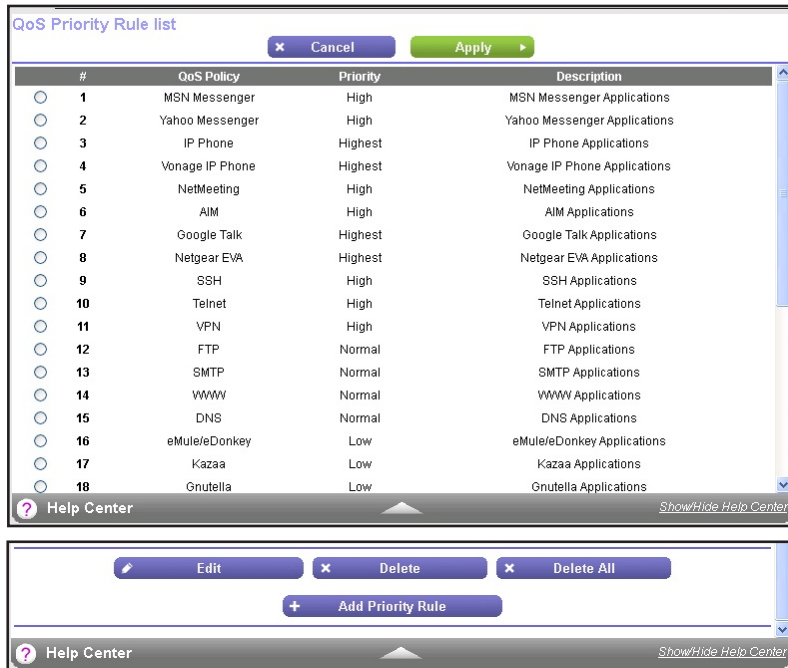

Scroll down

6. Click the **Add Priority Rule** button.

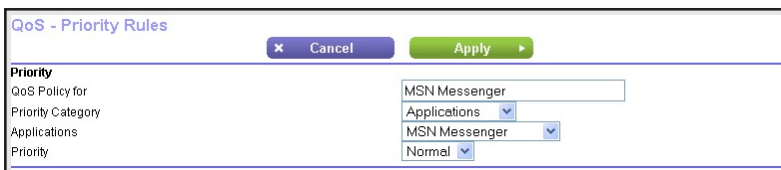

7. In the **QoS Policy for** field, type a descriptive name for the LAN port.

- In the **Priority Category** list, select **Ethernet LAN Port**.

QoS - Priority Rules

QoS Policy for: LAN Port 1

Priority Category: Ethernet LAN Port

LAN Port: 1

Priority: Normal

Buttons: Cancel, Apply

- From the **LAN Port** list, select the Ethernet LAN port number.
- From the **Priority** list, select the priority that this traffic should receive relative to other applications and traffic when accessing the Internet.

The options are Low, Normal, High, and Highest.

- Click the **Apply** button.

The rule is saved in the QoS Policy table.

The QoS Setup screen displays.

QoS for a MAC Address

- To create a QoS policy for traffic from a specific MAC address:

- Launch a web browser from a computer or WiFi device that is connected to the network.
- Enter **http://routerlogin.net** or **http://192.168.0.1**.

A login screen displays.

- Enter the router user name and password.

The user name is **admin**. The default password is **password**. The user name and password are case-sensitive.

The BASIC Home screen displays.

- Select **ADVANCED > Setup > QoS Setup**.

BASIC ADVANCED Auto

ADVANCED Home

Setup Wizard

WPS Wizard

Setup

Internet Setup

Wireless Setup

WAN Setup

LAN Setup

QoS Setup

USB Storage

Security

Administration

Advanced Setup

QoS Setup

Buttons: Cancel, Apply

Enable WMM (Wi-Fi multimedia) settings

Turn Internet Access QoS On

Turn Bandwidth Control On

Uplink bandwidth Maximum: 256 Kbps

Automatically check Internet Uplink bandwidth

Check

QoS Priority Rule list

Set Up QoS Rule

Enable Trusted IP address

Trusted IP Address

Buttons: ? Help Center, Show/Hide Help Center

- Click the **Set Up QoS Rule** button.

QoS Priority Rule list

| # | QoS Policy | Priority | Description | |
|-----------------------|------------|-----------------|-------------|------------------------------|
| <input type="radio"/> | 1 | MSN Messenger | High | MSN Messenger Applications |
| <input type="radio"/> | 2 | Yahoo Messenger | High | Yahoo Messenger Applications |
| <input type="radio"/> | 3 | IP Phone | Highest | IP Phone Applications |
| <input type="radio"/> | 4 | Vonage IP Phone | Highest | Vonage IP Phone Applications |
| <input type="radio"/> | 5 | NetMeeting | High | NetMeeting Applications |
| <input type="radio"/> | 6 | AIM | High | AIM Applications |
| <input type="radio"/> | 7 | Google Talk | Highest | Google Talk Applications |
| <input type="radio"/> | 8 | Netgear EVA | Highest | Netgear EVA Applications |
| <input type="radio"/> | 9 | SSH | High | SSH Applications |
| <input type="radio"/> | 10 | Telnet | High | Telnet Applications |
| <input type="radio"/> | 11 | VPN | High | VPN Applications |
| <input type="radio"/> | 12 | FTP | Normal | FTP Applications |
| <input type="radio"/> | 13 | SMTP | Normal | SMTP Applications |
| <input type="radio"/> | 14 | WWW | Normal | WWW Applications |
| <input type="radio"/> | 15 | DNS | Normal | DNS Applications |
| <input type="radio"/> | 16 | eMule/Donkey | Low | eMule/Donkey Applications |
| <input type="radio"/> | 17 | Kazaa | Low | Kazaa Applications |
| <input type="radio"/> | 18 | Gnutella | Low | Gnutella Applications |

Buttons: Edit, Delete, Delete All, Add Priority Rule

Help Center, Show/Hide Help Center

Scroll down

- Click the **Add Priority Rule** button.

QoS - Priority Rules

Buttons: Cancel, Apply

Priority

QoS Policy for: MSN Messenger

Priority Category: Applications

Applications: MSN Messenger

Priority: Normal

- In the **QoS Policy for** field, type a descriptive name for the MAC address.
- In the **Priority Category** list, select **MAC Address**.

QoS - Priority Rules

Buttons: Cancel, Apply

Priority

QoS Policy for: [Empty]

Priority Category: MAC Address

| QoS Policy | Priority | Device Name | MAC Address | |
|-----------------------|----------------|-------------|---------------|-------------------|
| <input type="radio"/> | Pri_MAC_12133F | Normal | MPAWLAN-SPARE | 00:13:02:12:13:3F |

MAC Address: [Empty]

Device Name: [Empty]

Priority: Normal

Buttons: Add, Edit, Delete, Refresh

- If the device for which you want to create a QoS policy is displayed in the MAC Device List, select its radio button.
The information from the MAC Device List populates the policy name, **MAC Address**, and **Device Name** fields.
- (Optional) If the device does not display in the MAC Device List, click the **Refresh** button.
If it still does not display, you must complete these fields manually.

- From the **Priority** list, select the priority that this traffic should receive relative to other applications and traffic when accessing the Internet.

The options are Low, Normal, High, and Highest.

- Click the **Apply** button.

The rule is saved in the QoS Policy table.

The QoS Setup screen displays.

Edit a MAC Address

- **To edit or delete a MAC address on the MAC Device List:**

- Launch a web browser from a computer or WiFi device that is connected to the network.
- Enter **http://routerlogin.net** or **http://192.168.0.1**.

A login screen displays.

- Enter the router user name and password.

The user name is **admin**. The default password is **password**. The user name and password are case-sensitive.

The BASIC Home screen displays.

- Select **ADVANCED > Setup > QoS Setup**.

The screenshot shows the QoS Setup page in the router's web interface. The page is divided into two tabs: BASIC and ADVANCED. The ADVANCED tab is selected. The page title is "QoS Setup". There are "Cancel" and "Apply" buttons at the top right. The page contains several sections:

- Enable WMM (Wi-Fi multimedia) settings:** A checkbox is checked.
- Turn Internet Access QoS On:** A checkbox is unchecked.
- Turn Bandwidth Control On:** A checkbox is unchecked. Below it, there are two radio buttons: "Uplink bandwidth Maximum" (selected) and "Automatically check Internet Uplink bandwidth". The "Uplink bandwidth Maximum" option has a value of "256" and a unit of "Kbps". A "Check" button is next to the "Automatically check Internet Uplink bandwidth" option.
- QoS Priority Rule list:** A section with a "Set Up QoS Rule" button.
- Enable Trusted IP address:** A checkbox is unchecked. Below it, there are four input fields for "Trusted IP Address".

The left sidebar contains a navigation menu with the following items: ADVANCED Home, Setup Wizard, WPS Wizard, Setup (expanded), Internet Setup, Wireless Setup, WAN Setup, LAN Setup, QoS Setup (highlighted), USB Storage, Security, Administration, and Advanced Setup. At the bottom of the page, there is a "Help Center" link and a "Show/Hide Help Center" button.

- Click the **Set Up QoS Rule** button.

QoS Priority Rule list

| # | QoS Policy | Priority | Description | |
|-----------------------|------------|-----------------|-------------|------------------------------|
| <input type="radio"/> | 1 | MSN Messenger | High | MSN Messenger Applications |
| <input type="radio"/> | 2 | Yahoo Messenger | High | Yahoo Messenger Applications |
| <input type="radio"/> | 3 | IP Phone | Highest | IP Phone Applications |
| <input type="radio"/> | 4 | Vonage IP Phone | Highest | Vonage IP Phone Applications |
| <input type="radio"/> | 5 | NetMeeting | High | NetMeeting Applications |
| <input type="radio"/> | 6 | AIM | High | AIM Applications |
| <input type="radio"/> | 7 | Google Talk | Highest | Google Talk Applications |
| <input type="radio"/> | 8 | Netgear EVA | Highest | Netgear EVA Applications |
| <input type="radio"/> | 9 | SSH | High | SSH Applications |
| <input type="radio"/> | 10 | Telnet | High | Telnet Applications |
| <input type="radio"/> | 11 | VPN | High | VPN Applications |
| <input type="radio"/> | 12 | FTP | Normal | FTP Applications |
| <input type="radio"/> | 13 | SMTP | Normal | SMTP Applications |
| <input type="radio"/> | 14 | WWW | Normal | WWW Applications |
| <input type="radio"/> | 15 | DNS | Normal | DNS Applications |
| <input type="radio"/> | 16 | eMule/Donkey | Low | eMule/Donkey Applications |
| <input type="radio"/> | 17 | Kazaa | Low | Kazaa Applications |
| <input type="radio"/> | 18 | Gnutella | Low | Gnutella Applications |

Buttons: Edit, Delete, Delete All, Add Priority Rule

Scroll down

- Click the **Add Priority Rule** button.

QoS - Priority Rules

Priority

QoS Policy for: MSN Messenger

Priority Category: Applications

Applications: MSN Messenger

Priority: Normal

- In the **Priority Category** list, select **MAC Address**.

QoS - Priority Rules

Priority

QoS Policy for: []

Priority Category: MAC Address

| QoS Policy | Priority | Device Name | MAC Address | |
|-----------------------|----------------|-------------|---------------|-------------------|
| <input type="radio"/> | Pri_MAC_12133F | Normal | MPAWLAN-SPARE | 00:13:02:12:13:3F |

MAC Address: []

Device Name: []

Priority: Normal

Buttons: Add, Edit, Delete, Refresh

- Select the radio button next to the device that you want to edit.
- Click the **Edit** button.
- Edit the information you want to change.

Note: You cannot edit a device that is detected and automatically added to the MAC Device List.

- Click the **Apply** button.

The device information is saved from the MAC Device List.

Delete a MAC Address

➤ To delete a MAC address on the MAC Device List:

1. Launch a web browser from a computer or WiFi device that is connected to the network.
2. Enter <http://routerlogin.net> or <http://192.168.0.1>.

A login screen displays.

3. Enter the router user name and password.

The user name is **admin**. The default password is **password**. The user name and password are case-sensitive.

The BASIC Home screen displays.

4. Select **ADVANCED > Setup > QoS Setup**.

The screenshot shows the QoS Setup page in the router's web interface. The page is titled "QoS Setup" and has a "Cancel" button and an "Apply" button. The "Enable WMM (Wi-Fi multimedia) settings" checkbox is checked. The "Turn Internet Access QoS On" checkbox is unchecked. The "Turn Bandwidth Control On" checkbox is unchecked. The "Uplink bandwidth Maximum" is set to 256 Kbps. The "Automatically check Internet Uplink bandwidth" checkbox is unchecked. The "Check" button is visible. The "QoS Priority Rule list" section is empty. The "Set Up QoS Rule" button is visible. The "Enable Trusted IP address" checkbox is unchecked. The "Trusted IP Address" field is empty. The page has a "Help Center" link at the bottom left and a "Show/Hide Help Center" link at the bottom right.

- Click the **Set Up QoS Rule** button.

QoS Priority Rule list

| # | QoS Policy | Priority | Description | |
|-----------------------|------------|-----------------|-------------|------------------------------|
| <input type="radio"/> | 1 | MSN Messenger | High | MSN Messenger Applications |
| <input type="radio"/> | 2 | Yahoo Messenger | High | Yahoo Messenger Applications |
| <input type="radio"/> | 3 | IP Phone | Highest | IP Phone Applications |
| <input type="radio"/> | 4 | Vonage IP Phone | Highest | Vonage IP Phone Applications |
| <input type="radio"/> | 5 | NetMeeting | High | NetMeeting Applications |
| <input type="radio"/> | 6 | AIM | High | AIM Applications |
| <input type="radio"/> | 7 | Google Talk | Highest | Google Talk Applications |
| <input type="radio"/> | 8 | Netgear EVA | Highest | Netgear EVA Applications |
| <input type="radio"/> | 9 | SSH | High | SSH Applications |
| <input type="radio"/> | 10 | Telnet | High | Telnet Applications |
| <input type="radio"/> | 11 | VPN | High | VPN Applications |
| <input type="radio"/> | 12 | FTP | Normal | FTP Applications |
| <input type="radio"/> | 13 | SMTP | Normal | SMTP Applications |
| <input type="radio"/> | 14 | WWW | Normal | WWW Applications |
| <input type="radio"/> | 15 | DNS | Normal | DNS Applications |
| <input type="radio"/> | 16 | eMule/Donkey | Low | eMule/Donkey Applications |
| <input type="radio"/> | 17 | Kazaa | Low | Kazaa Applications |
| <input type="radio"/> | 18 | Gnutella | Low | Gnutella Applications |

Buttons: Edit, Delete, Delete All, Add Priority Rule

Scroll down

- Click the **Add Priority Rule** button.

QoS - Priority Rules

Priority

QoS Policy for: MSN Messenger

Priority Category: Applications

Applications: MSN Messenger

Priority: Normal

- In the **Priority Category** list, select **MAC Address**.

QoS - Priority Rules

Priority

QoS Policy for: []

Priority Category: MAC Address

| QoS Policy | Priority | Device Name | MAC Address | |
|-----------------------|----------------|-------------|---------------|-------------------|
| <input type="radio"/> | Pri_MAC_12133F | Normal | MPAWLAN-SPARE | 00:13:02:12:13:3F |

MAC Address: []

Device Name: []

Priority: Normal

Buttons: Add, Edit, Delete, Refresh

- Select the radio button next to the device that you want to delete.
- Click the **Delete** button.

Note: You cannot delete a device that is detected and automatically added to the MAC Device List.

- Click the **Apply** button.

The device information is removed from the MAC Device List.

Edit an Existing QoS policy

➤ To edit a QoS policy:

1. Launch a web browser from a computer or WiFi device that is connected to the network.
2. Enter **http://routerlogin.net** or **http://192.168.0.1**.

A login screen displays.

3. Enter the router user name and password.

The user name is **admin**. The default password is **password**. The user name and password are case-sensitive.

The BASIC Home screen displays.

4. Select **ADVANCED > Setup > QoS Setup**.

The screenshot shows the QoS Setup page in the router's web interface. The page is titled "QoS Setup" and has a "Cancel" button and an "Apply" button. The "Enable WMM (Wi-Fi multimedia) settings" checkbox is checked. The "Turn Internet Access QoS On" checkbox is unchecked. The "Turn Bandwidth Control On" checkbox is unchecked. The "Uplink bandwidth Maximum" is set to 256 Kbps. The "Automatically check Internet Uplink bandwidth" checkbox is unchecked. The "QoS Priority Rule list" section is empty. The "Enable Trusted IP address" checkbox is unchecked. The "Trusted IP Address" field is empty. The "Set Up QoS Rule" button is visible. The page also includes a "Help Center" link and a "Show/Hide Help Center" link.

5. Click the **Set Up QoS Rule** button.

QoS Priority Rule list

| # | QoS Policy | Priority | Description | |
|-----------------------|------------|-----------------|-------------|------------------------------|
| <input type="radio"/> | 1 | MSN Messenger | High | MSN Messenger Applications |
| <input type="radio"/> | 2 | Yahoo Messenger | High | Yahoo Messenger Applications |
| <input type="radio"/> | 3 | IP Phone | Highest | IP Phone Applications |
| <input type="radio"/> | 4 | Vonage IP Phone | Highest | Vonage IP Phone Applications |
| <input type="radio"/> | 5 | NetMeeting | High | NetMeeting Applications |
| <input type="radio"/> | 6 | AIM | High | AIM Applications |
| <input type="radio"/> | 7 | Google Talk | Highest | Google Talk Applications |
| <input type="radio"/> | 8 | Netgear EVA | Highest | Netgear EVA Applications |
| <input type="radio"/> | 9 | SSH | High | SSH Applications |
| <input type="radio"/> | 10 | Telnet | High | Telnet Applications |
| <input type="radio"/> | 11 | VPN | High | VPN Applications |
| <input type="radio"/> | 12 | FTP | Normal | FTP Applications |
| <input type="radio"/> | 13 | SMTP | Normal | SMTP Applications |
| <input type="radio"/> | 14 | WWW | Normal | WWW Applications |
| <input type="radio"/> | 15 | DNS | Normal | DNS Applications |
| <input type="radio"/> | 16 | eMule/eDonkey | Low | eMule/eDonkey Applications |
| <input type="radio"/> | 17 | Kazaa | Low | Kazaa Applications |
| <input type="radio"/> | 18 | Gnutella | Low | Gnutella Applications |

Buttons: Edit, Delete, Delete All, Add Priority Rule

Help Center | Show/Hide Help Center

Scroll down

6. Select the radio button next to the QoS policy that you want to edit.
7. Click the **Edit** button.
8. Click the **Apply** button.
- Your changes are saved.

Delete an Existing QoS policy

➤ To delete a QoS policy:

1. Launch a web browser from a computer or WiFi device that is connected to the network.
2. Enter **http://routerlogin.net** or **http://192.168.0.1**.

A login screen displays.

3. Enter the router user name and password.

The user name is **admin**. The default password is **password**. The user name and password are case-sensitive.

The BASIC Home screen displays.

4. Select **ADVANCED > Setup > QoS Setup**.

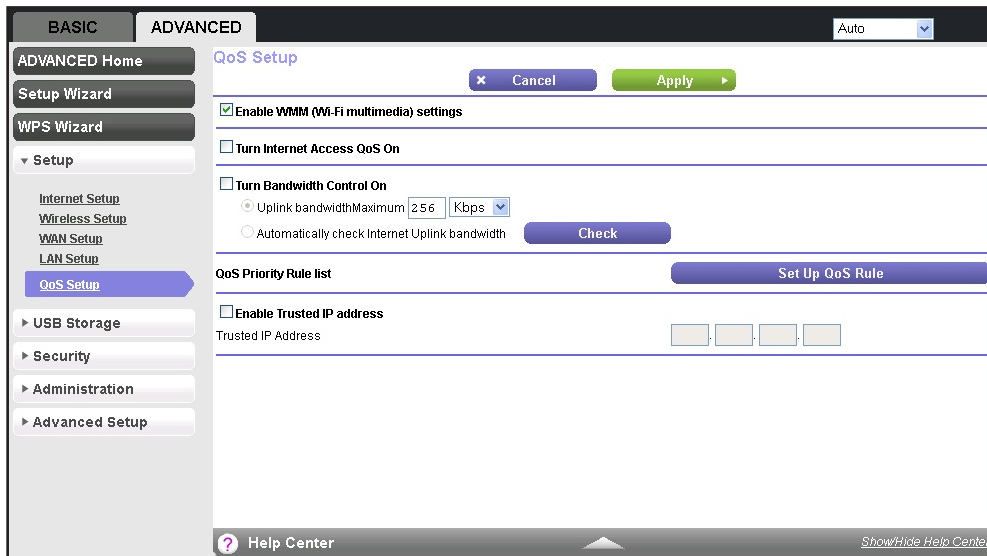

5. Click the **Set Up QoS Rule** button.

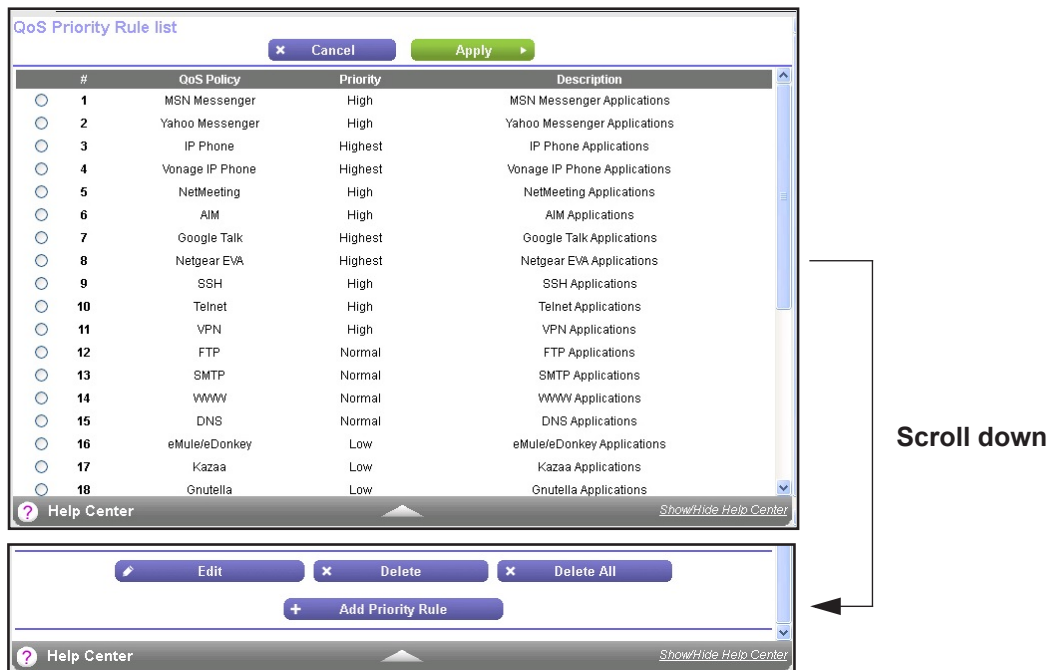

6. Select the radio button next to the QoS policy that you want to delete.
 7. Click the **Delete** button.
 8. Click the **Apply** button.
- The QoS policy is removed.

Set Up Bandwidth Control

Bandwidth control lets you set a limit to the bandwidth that is available for traffic from the router to the Internet.

➤ **To set the maximum uplink bandwidth:**

1. Launch a web browser from a computer or WiFi device that is connected to the network.
2. Enter **http://routerlogin.net** or **http://192.168.0.1**.

A login screen displays.

3. Enter the router user name and password.

The user name is **admin**. The default password is **password**. The user name and password are case-sensitive.

The BASIC Home screen displays.

4. Select **ADVANCED > Setup > QoS Setup**.

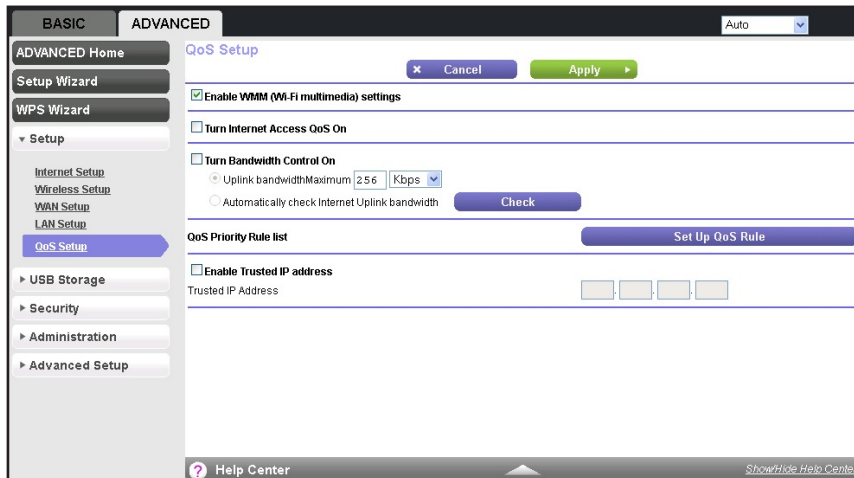

5. Select the **Turn Bandwidth Control On** check box.
6. Specify the maximum uplink bandwidth for your Internet connection:
 - If you know what your uplink bandwidth is, select the **Uplink bandwidth** radio button, type the maximum bandwidth that you want to allow, and select either **Kbps** or **Mbps** from the drop-down list.
 - If you are not sure, select **Automatically check Internet Uplink bandwidth** radio button and click the **Check** button.

The router detects the available uplink bandwidth. After about one minute, the available bandwidth displays on the screen. This information can help you to determine the maximum bandwidth setting that you want to allow.

7. Click the **Apply** button.

Your changes are saved.

Improve Network Connections with Universal Plug and Play

Universal Plug and Play (UPnP) helps devices, such as Internet appliances and computers, access the network and connect to other devices as needed. UPnP devices can automatically discover the services from other registered UPnP devices on the network.

If you use applications such as multiplayer gaming, peer-to-peer connections, or real-time communications such as instant messaging or remote assistance (a feature in Windows XP), enable UPnP.

➤ To enable Universal Plug and Play:

1. Launch a web browser from a computer or WiFi device that is connected to the network.
2. Enter **http://routerlogin.net** or **http://192.168.0.1**.

A login screen displays.

3. Enter the router user name and password.

The user name is **admin**. The default password is **password**. The user name and password are case-sensitive.

The BASIC Home screen displays.

4. Select **ADVANCED > Advanced Setup > UPnP**.

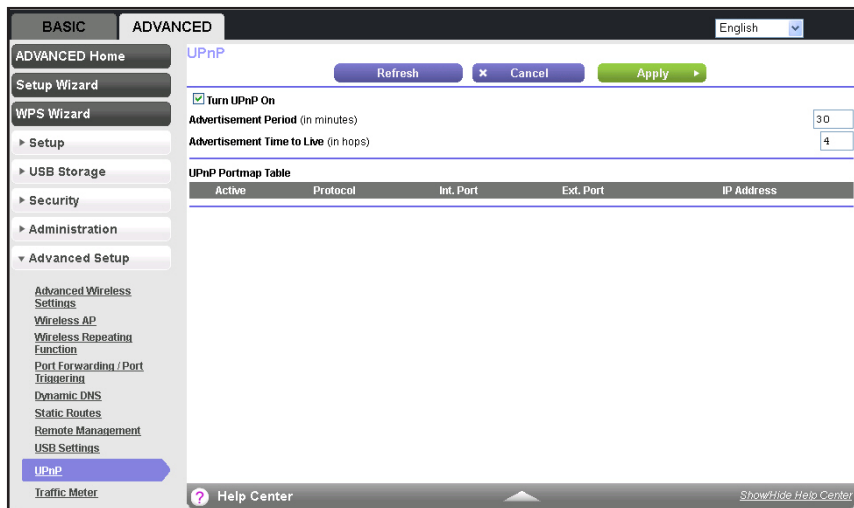

5. Select the **Turn UPnP On** check box.

By default, this check box is selected. If the **Turn UPnP On** check box is cleared, the router does not allow any device to automatically control router resources, such as port forwarding.

6. Type the advertisement period in minutes.

The advertisement period specifies how often the router broadcasts its UPnP information. This value can range from 1 to 1440 minutes. The default period is 30 minutes. Shorter

durations ensure that control points have current device status at the expense of more network traffic. Longer durations can compromise the freshness of the device status, but can significantly reduce network traffic.

7. Type the advertisement time to live in hops.

The time to live for the advertisement is measured in hops (steps) for each UPnP packet sent. Hops are the steps a packet takes between routers. The number of hops can range from 1 to 255. The default value for the advertisement time to live is 4 hops, which should be fine for most home networks. If you notice that some devices are not being updated or reached correctly, it might be necessary to increase this value.

8. Click the **Apply** button.

The UPnP Portmap Table displays the IP address of each UPnP device that is accessing the router and which ports (internal and external) that device has opened. The UPnP Portmap Table also displays what type of port is open and whether that port is still active for each IP address.

9. To refresh the information in the UPnP Portmap Table, click the **Refresh** button.

Manage Your Network

6

This chapter describes the router settings for administering and maintaining your router and home network.

This chapter includes the following sections:

- *Update the Router Firmware*
- *Change the admin Password*
- *Recover the admin Password*
- *View Router Status*
- *View the Internet Connection Settings*
- *View Wireless Settings*
- *View Guest Network Settings*
- *View Logs of Web Access or Attempted Web Access*
- *Manage the Configuration File*
- *Traffic Meter*
- *Reboot the Router*
- *Remote Management*
- *Configure FastLane Settings*

Update the Router Firmware

The router firmware (routing software) is stored in flash memory. You might see a message at the top of the genie screens when new firmware is available. You can respond to that message to update the firmware, or you can check to see if new firmware is available, and to update your product.

➤ **To check for new firmware and update your router:**

1. Launch a web browser from a computer or WiFi device that is connected to the network.
2. Enter **http://www.routerlogin.net** or **http://www.routerlogin.com**.

A login screen displays.

3. Enter the router user name and password.

The user name is **admin**. The default password is **password**. The user name and password are case-sensitive.

The BASIC Home screen displays.

4. Select **ADVANCED > Administration > Firmware Update**.
5. Click the **Check** button.

The router finds new firmware information if any is available and displays a message asking if you want to download and install it.

6. Click the **Yes** button.

The router locates and downloads the firmware.

7. To upload the firmware that you have downloaded from the NETGEAR support website, do the following:
 - a. Click **Browse**, navigate to the firmware file (the file ends in `.img`), and select the firmware file.
 - b. Click the **Upload** button.



WARNING:

To avoid the risk of corrupting the firmware, do not interrupt the upgrade. For example, do not close the browser, click a link, or load a new page. Do not turn off the router.

A progress bar shows the progress of the firmware upload process.

When the upload is complete, your router restarts. The upload process can take up to three minutes, and the upgrade process typically takes about one minute. To determine whether you need to reconfigure the router after upgrading, read the new firmware release notes.

Change the admin Password

This feature let you change the default password that is used to log in to the router with the user name admin. This password is not the one that you use for WiFi access. The product label shows your unique wireless network name (SSID) and password for wireless access.

➤ **To set the password for the user name admin:**

1. Launch a web browser from a computer or WiFi device that is connected to the network.
2. Enter <http://www.routerlogin.net> or <http://www.routerlogin.com>.

A login screen displays.

3. Enter the router user name and password.

The user name is **admin**. The default password is **password**. The user name and password are case-sensitive.

The BASIC Home screen displays.

4. Select **ADVANCED > Administration > Set Password**.

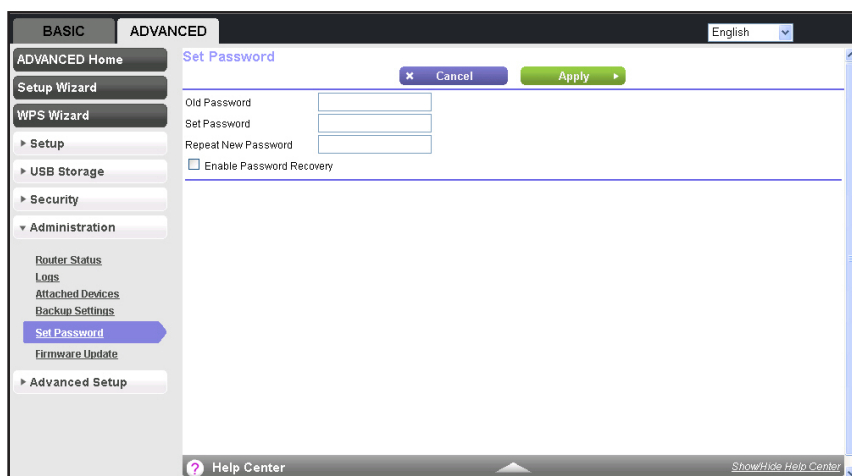

5. Type the old password, and type the new password twice.
6. To be able to recover the password, select the **Enable Password Recovery** check box. NETGEAR recommends that you enable password recovery.
7. Click the **Apply** button. Your changes are saved.

Recover the admin Password

NETGEAR recommends that you enable password recovery if you change the password for the router user name admin. Then you can recover the password if it is forgotten. This recovery process is supported in Internet Explorer, Firefox, and Chrome browsers, but not in the Safari browser.

➤ **To set up password recovery:**

1. Launch a web browser from a computer or WiFi device that is connected to the network.
2. Enter **http://www.routerlogin.net** or **http://www.routerlogin.com**.
A login screen displays.
3. Enter the router user name and password.
The user name is **admin**. The default password is **password**. The user name and password are case-sensitive.
The BASIC Home screen displays.
4. Select **ADVANCED > Administration > Set Password**.
The Set Password screen displays.
5. Select the **Enable Password Recovery** check box.
6. Select two security questions and provide answers to them.
7. Click the **Apply** button.
Your changes are saved.

➤ **To recover your password:**

1. In the address field of your browser, enter **www.routerlogin.net**.
A login screen displays.
2. Click the **Cancel** button.
If password recovery is enabled, you are prompted to enter the serial number of the router.
The serial number is on the product label.
3. Enter the serial number of the router.
4. Click the **Continue** button.
A screen displays requesting the answers to your security questions.
5. Enter the saved answers to your security questions.
6. Click the **Continue** button.
A screen displays your recovered password.
7. Click the **Login again** button.
A login screen displays.
8. With your recovered password, log in to the router.

View Router Status

➤ To view router status and usage information:

1. Launch a web browser from a computer or WiFi device that is connected to the network.
2. Enter <http://www.routerlogin.net> or <http://www.routerlogin.com>.

A login screen displays.

3. Enter the router user name and password.

The user name is **admin**. The default password is **password**. The user name and password are case-sensitive.

The BASIC Home screen displays.

4. Click the **ADVANCED** tab.

The Router Information pane displays the following information:

- **Hardware Version.** The router model.
- **Firmware Version.** The version of the router firmware. It changes if you upgrade the router firmware.
- **GUI Language Version.** The localized language of the router user interface.
- **LAN Port:**
 - **MAC Address.** The Media Access Control address for the Ethernet (LAN) port. This address is the unique physical address that the Ethernet (LAN) port of the router uses.
 - **IP Address.** The IP address that the Ethernet (LAN) port of the router uses. The default is 192.168.1.1.
 - **DHCP Server.** Identifies whether the router's built-in DHCP server is active for the LAN-attached devices.

View the Internet Connection Settings

- **To view the Internet connection settings:**
1. Launch a web browser from a computer or WiFi device that is connected to the network.
 2. Enter **http://www.routerlogin.net** or **http://www.routerlogin.com**.
A login screen displays.
 3. Enter the router user name and password.
The user name is **admin**. The default password is **password**. The user name and password are case-sensitive.
The BASIC Home screen displays.
 4. Click the **ADVANCED** tab.
The Internet Port pane displays the following information:
 - **MAC Address.** The Media Access Control (MAC) address for the Internet port. This address is the unique physical address that the Internet (WAN) port of the router uses.
 - **IP Address.** The IP address that the Internet (WAN) port of the router uses. If no address is shown or the address is 0.0.0.0, the router is not connected to the Internet.
 - **Connection.** Shows whether the router is using a fixed or dynamic IP address on the Internet port. If the value is DHCP, the router obtains an IP address dynamically from the ISP or from a DHCP server on your LAN.
 - **IP Subnet Mask.** The IP subnet mask that the Internet port of the router uses.
 - **Domain Name Server.** The Domain Name Server address that the router uses. A Domain Name Server translates human-language URLs such as www.netgear.com into IP addresses.

Display Internet Port Statistics

- **To display Internet port statistics:**
1. Launch a web browser from a computer or WiFi device that is connected to the network.
 2. Enter **http://www.routerlogin.net** or **http://www.routerlogin.com**.
A login screen displays.
 3. Enter the router user name and password.
The user name is **admin**. The default password is **password**. The user name and password are case-sensitive.
 4. The BASIC Home screen displays
 5. Click the **ADVANCED** tab.

6. In the Internet Port pane, click the **Show Statistics** button.

| System Up Time 97:24:13 | | | | | |
|-------------------------|-----------|--------|--------|------------|----------|
| Port | Status | TxPkts | RxPkts | Collisions | Up Time |
| WAN | 1000MFull | 11270 | 376786 | 0 | 97:23:10 |
| LAN1 | Link down | -- | -- | -- | -- |
| LAN2 | Link down | -- | -- | -- | -- |
| LAN3 | Link down | -- | -- | -- | -- |
| LAN4 | Link down | -- | -- | -- | -- |
| WLAN b/g/n | 300M | 0 | 0 | 0 | 97:23:20 |
| WLAN a/n | 450M | 23561 | 160829 | 0 | 97:23:20 |

Poll Interval: (secs)

The following information displays:

- **System Up Time.** The time elapsed since the router was last restarted.
 - **Port.** The statistics for the WAN (Internet) and LAN (Ethernet) ports. For each port, the screen displays the following information:
 - **Status.** The link status of the port.
 - **TxPkts.** The number of packets transmitted on this port since reset or manual clear.
 - **RxPkts.** The number of packets received on this port since reset or manual clear.
 - **Collisions.** The number of collisions on this port since reset or manual clear.
 - **Up Time.** The time elapsed since this port acquired the link.
 - **Poll Interval.** The interval at which the statistics are updated in this screen.
7. To change the polling frequency, enter a time in seconds in the **Poll Interval** field and click the **Set Interval** button.

To stop the polling, click the **Stop** button.

View the Internet Connection Status

➤ To check the Internet connection status:

1. Launch a web browser from a computer or WiFi device that is connected to the network.
2. Enter <http://www.routerlogin.net> or <http://www.routerlogin.com>.

A login screen displays.

3. Enter the router user name and password.

The user name is **admin**. The default password is **password**. The user name and password are case-sensitive.

The BASIC Home screen displays.

4. Click the **ADVANCED** tab.
5. In the Internet Port pane, click the **Connection Status** button.

The Connection Status pop-up screen displays. The following figure shows the connection status information for a DHCP connection.



The content of the Connection Status pop-up screen depends on the type of connection. You can start new connections and end existing connections from this screen.

The following list describes the different types of connections and the associated settings that display on the Connection Status pop-up screen.

DHCP Connection

The following information displays for a DHCP connection:

- **IP Address.** The IP address that is assigned to the router.
- **Subnet Mask.** The subnet mask that is assigned to the router.
- **Default Gateway.** The IP address for the default gateway that the router communicates with.
- **DHCP Server.** The IP address for the Dynamic Host Configuration Protocol server that configures the TCP/IP for all the computers that are connected to the router.
- **DNS Server.** The IP address of the Domain Name Service server that translates of network names to IP addresses.
- **Lease Obtained.** The date and time when the lease was obtained.
- **Lease Expires.** The date and time that the lease expires.

➤ To release the router's IP address and terminate the Internet connection:

1. Launch a web browser from a computer or WiFi device that is connected to the network.
2. Enter **http://www.routerlogin.net** or **http://www.routerlogin.com**.

A login screen displays.

3. Enter the router user name and password.

The user name is **admin**. The default password is **password**. The user name and password are case-sensitive.

The BASIC Home screen displays.

4. Click the **ADVANCED** tab.
1. In the Internet Port pane, click the **Connection Status** button.

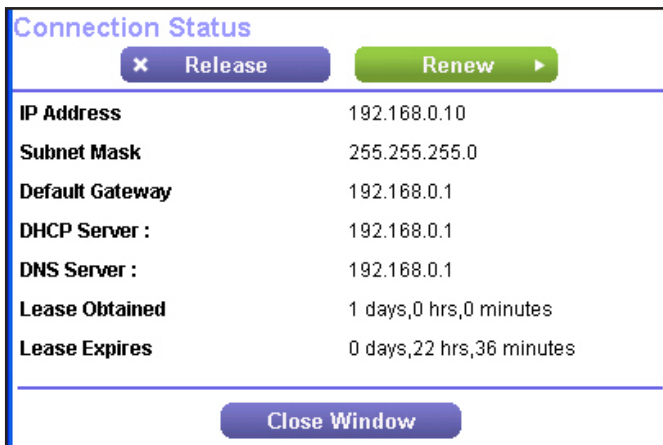

2. Click the **Release** button.
3. To close the Connection Status screen, click the **Close Window** button.

➤ **To acquire an IP address from the DHCP server and start the Internet connection:**

1. Launch a web browser from a computer or WiFi device that is connected to the network.
2. Enter **http://www.routerlogin.net** or **http://www.routerlogin.com**.

A login screen displays.

3. Enter the router user name and password.

The user name is **admin**. The default password is **password**. The user name and password are case-sensitive.

The BASIC Home screen displays.

4. Click the **ADVANCED** tab.
1. In the Internet Port pane, click the **Connection Status** button.

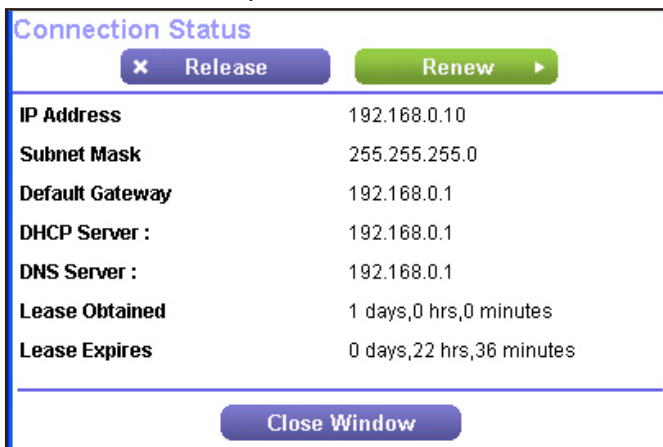

2. Click the **Renew** button.
3. To close the Connection Status screen, click the **Close Window** button.

PPPoE Connection

The **Connect** and **Disconnect** buttons in the Connection Status screen display only when the connection mode is Manually Connect.

The following information displays for a PPPoE connection:

- **Connection Time.** The time that elapsed since the connection was established.
- **Connection Status.** The status of the connection: Connected, Disconnected, Negotiation (---, Success), or Authentication (---, Success). --- indicates failure.
- **IP Address.** The IP address that is assigned to the router.
- **Subnet Mask.** The subnet mask that is assigned to the router.

➤ To establish the PPPoE connection manually:

1. Launch a web browser from a computer or WiFi device that is connected to the network.
2. Enter **http://www.routerlogin.net** or **http://www.routerlogin.com**.

A login screen displays.

3. Enter the router user name and password.

The user name is **admin**. The default password is **password**. The user name and password are case-sensitive.

The BASIC Home screen displays.

4. Click the **ADVANCED** tab.

1. In the Internet Port pane, click the **Connection Status** button.
2. Click the **Connect** button.
3. To close the Connection Status screen, click the **Close Window** button.

➤ To terminate the PPPoE connection manually:

1. Launch a web browser from a computer or WiFi device that is connected to the network.
2. Enter **http://www.routerlogin.net** or **http://www.routerlogin.com**.

A login screen displays.

3. Enter the router user name and password.

The user name is **admin**. The default password is **password**. The user name and password are case-sensitive.

The BASIC Home screen displays.

4. Click the **ADVANCED** tab.

5. In the Internet Port pane, click the **Connection Status** button.
6. Click the **Disconnect** button.
7. To close the Connection Status screen, click the **Close Window** button.

PPTP Connection

The content of the Connection Status pop-up screen depends on the type of connection. The **Connect** and **Disconnect** buttons in the Connection Status screen display only when the connection mode is Manually Connect.

The following information displays for a PPTP connection:

- **Connection Status.** The status of the connection: Connected or Disconnected.
- **IP Address.** The IP address that is assigned to the router.
- **Subnet Mask.** The subnet mask that is assigned to the router.

➤ To establish the PPTP connection manually:

1. Launch a web browser from a computer or WiFi device that is connected to the network.
2. Enter **http://www.routerlogin.net** or **http://www.routerlogin.com**.

A login screen displays.

3. Enter the router user name and password.

The user name is **admin**. The default password is **password**. The user name and password are case-sensitive.

The BASIC Home screen displays.

4. Click the **ADVANCED** tab.

1. In the Internet Port pane, click the **Connection Status** button.
2. Click the **Connect** button.
3. To close the Connection Status screen, click the **Close Window** button.

➤ To terminate the PPTP connection manually:

1. Launch a web browser from a computer or WiFi device that is connected to the network.
2. Enter **http://www.routerlogin.net** or **http://www.routerlogin.com**.

A login screen displays.

3. Enter the router user name and password.

The user name is **admin**. The default password is **password**. The user name and password are case-sensitive.

The BASIC Home screen displays.

4. Click the **ADVANCED** tab.

5. In the Internet Port pane, click the **Connection Status** button.
6. Click the **Disconnect** button.
7. To close the Connection Status screen, click the **Close Window** button.

View Wireless Settings

➤ To view the wireless settings:

1. Launch a web browser from a computer or WiFi device that is connected to the network.
2. Enter **http://www.routerlogin.net** or **http://www.routerlogin.com**.

A login screen displays.

3. Enter the router user name and password.

The user name is **admin**. The default password is **password**. The user name and password are case-sensitive.

The BASIC Home screen displays.

4. Click the **ADVANCED** tab.

The Wireless Settings pane displays the following information:

- **Name (SSID)**. The wireless network name (SSID) that the router uses.
- **Region**. The geographic region where the router is used. It might be illegal to use the wireless features of the router in some parts of the world.
- **Channel**. The operating channel of the wireless port. The default channel is Auto. When Auto is selected, the router finds the best operating channel available.
- **Mode**. The wireless communication mode: Up to 54 Mbps, Up to 150 Mbps (the default), or Up to 300 Mbps.
- **Wireless AP**. Indicates whether the radio of the router is enabled. If the radio is not enabled, the WiFi LED on the front panel is off.
- **Broadcast Name**. Indicates whether the router is broadcasting its SSID.
- **Wireless Isolation**. Indicates whether wireless isolation is on or off. When it is off, wireless clients (computers or WiFi devices) that join the network can use the Internet, but cannot access each other or access Ethernet devices on the network.
- **Wi-Fi Protected Setup**. Indicates whether Wi-Fi Protected Setup is configured for this network.

View Guest Network Settings

➤ To view the guest network settings:

1. Launch a web browser from a computer or WiFi device that is connected to the network.
2. Enter **http://www.routerlogin.net** or **http://www.routerlogin.com**.

A login screen displays.

3. Enter the router user name and password.

The user name is **admin**. The default password is **password**. The user name and password are case-sensitive.

The BASIC Home screen displays.

4. Click the **ADVANCED** tab.

The Guest Network pane displays the following information:

- **Name (SSID).** The wireless network name (SSID) that the router uses. The default name is NETGEAR-Guest.
- **Wireless AP.** Indicates whether the radio of the router is enabled for the guest network.
- **Broadcast Name.** Indicates whether the router is broadcasting its SSID for the guest network.
- **Wireless Isolation.** Indicates whether wireless isolation is on or off for the guest network. When it is off, wireless clients (computers or WiFi devices) that join the guest network can use the Internet, but cannot access each other or access Ethernet devices on the network.
- **Allow guest to access My Local Network.** Indicates whether wireless clients on the guest network can access your local network, instead of only the Internet and other wireless clients on the guest network.

View Logs of Web Access or Attempted Web Access

A log is a detailed record of the websites that users on your network have accessed or attempted to access. If you have set up content filtering on the Block Sites screen, the Logs screen shows you when someone on your network tried to access a blocked site. If you have email notification on, you receive these logs in an email message. If you do not have email notification set up, you can view the logs here.

➤ **To view the logs:**

1. Launch a web browser from a computer or WiFi device that is connected to the network.
2. Enter **<http://www.routerlogin.net>** or **<http://www.routerlogin.com>**.

A login screen displays.

3. Enter the router user name and password.

The user name is **admin**. The default password is **password**. The user name and password are case-sensitive.

The BASIC Home screen displays.

4. Select **ADVANCED > Administration > Logs**.

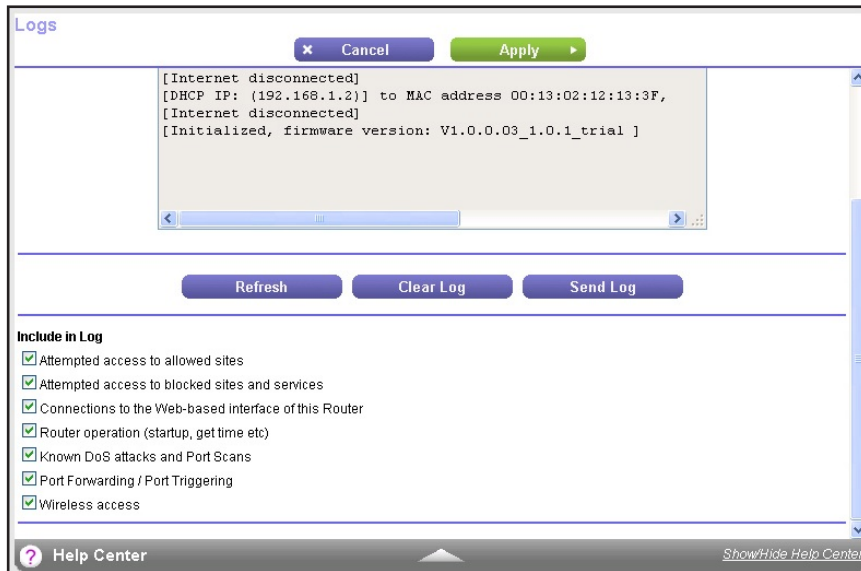

5. Select the check boxes for the events that you want to include in the log:

- **Attempted access to allowed sites**
- **Attempted access to blocked sites and services**
- **Connections to the Web-based interface of this Router**
- **Router operation (startup, get time etc)**
- **Known DoS attacks and Port Scans**
- **Port Forwarding / Port Triggering**
- **Wireless access**

6. Click the **Apply** button.

Your changes are saved.

Manage the Configuration File

The configuration settings of the router are stored within the router in a configuration file. You can back up (save) this file to your computer, restore it, or reset it to the factory default settings.

Back Up Settings

➤ **To back up the router's configuration settings:**

1. Launch a web browser from a computer or WiFi device that is connected to the network.
2. Enter **http://www.routerlogin.net** or **http://www.routerlogin.com**.

A login screen displays.

3. Enter the router user name and password.

The user name is **admin**. The default password is **password**. The user name and password are case-sensitive.

The BASIC Home screen displays.

4. Select **ADVANCED > Administration > Backup Settings**.

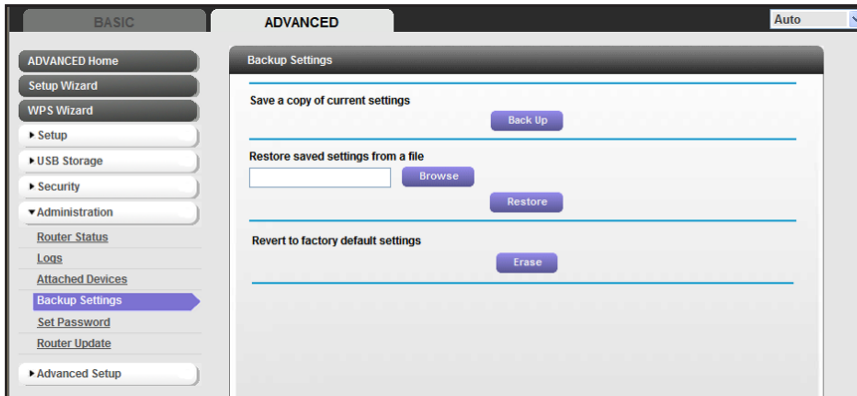

5. To save a copy of the current settings, click the **Back Up** button.
6. Choose a location to store the `.cfg` file on a computer on your network.
7. Click the **OK** button.

A copy of the current settings is saved.

Restore Configuration Settings

- **To restore configuration settings that you backed up:**

1. Launch a web browser from a computer or WiFi device that is connected to the network.
2. Enter <http://www.routerlogin.net> or <http://www.routerlogin.com>.

A login screen displays.

3. Enter the router user name and password.

The user name is **admin**. The default password is **password**. The user name and password are case-sensitive.

The BASIC Home screen displays.

4. Select **ADVANCED > Administration > Backup Settings**.

The Backup Settings screen displays.

5. To find the `.cfg` file, click the **Browse** button.
6. Select the file and then click the **Restore** button.

The file is uploaded to the router.

The router reboots.

**WARNING:**

Do not interrupt the reboot process.

Erase Configuration Settings

Under some circumstances (for example, if you move the router to a different network), you might want to erase the configuration and restore the factory default settings.

You can either use the Restore Factory Settings button on the back of the router (see *Factory Default Settings* on page 156), or you can use the **Erase** button on the Backup Settings screen.

➤ **To erase the configuration and restore the factory default settings:**

1. Launch a web browser from a computer or WiFi device that is connected to the network.
2. Enter **http://www.routerlogin.net** or **http://www.routerlogin.com**.

A login screen displays.

3. Enter the router user name and password.

The user name is **admin**. The default password is **password**. The user name and password are case-sensitive.

The BASIC Home screen displays.

4. Select **ADVANCED > Administration > Backup Settings**.

The Backup Settings screen displays.

5. Click the **Erase** button.

6. To confirm the action click the **Yes** button.

The router reboots.

**WARNING:**

Do not interrupt the reboot process.

Erasing sets the user name to admin, the password to password, and the LAN IP address to 192.168.1.1, and enables the router's DHCP server.

Traffic Meter

Traffic metering allows you to monitor the volume of Internet traffic passing through your router's Internet port. With the traffic meter utility, you can set limits for traffic volume, set a monthly limit, and get a live update of traffic usage.

➤ **To start monitoring Internet traffic:**

1. Launch a web browser from a computer or WiFi device that is connected to the network.
2. Enter **http://www.routerlogin.net** or **http://www.routerlogin.com**.

A login screen displays.

3. Enter the router user name and password.

The user name is **admin**. The default password is **password**. The user name and password are case-sensitive.

The BASIC Home screen displays.

4. Select **ADVANCED > Advanced Setup > Traffic Meter**.

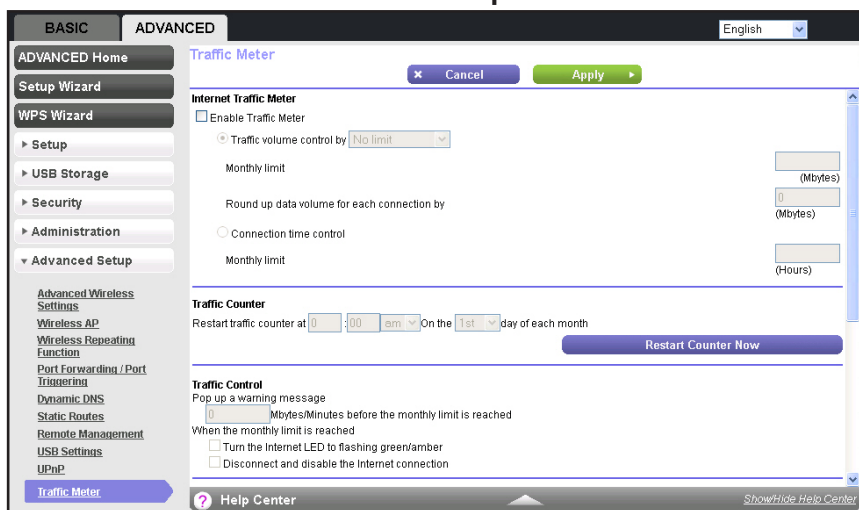

5. Select the **Enable Traffic Meter** check box.
6. (Optional) Control the volume of Internet traffic.

You can use either the traffic volume control feature or the connection time control feature:

- **Traffic volume control by.** Select one of the following options:
 - **No Limit.** No restriction is applied when the traffic limit is reached.
 - **Download only.** The restriction is applied to incoming traffic only.
 - **Both Directions.** The restriction is applied to both incoming and outgoing traffic.
 - **Connection time control.** Enter the allowed hours in the **Monthly limit** field.
7. (Optional) If your ISP charges for extra data volume when you make a new connection, enter the extra data volume in MB in the **Round up data volume for each connection by** field.
 8. In the Traffic Counter section, set up the traffic counter to begin at a specific time and date of each month.

If you want the traffic counter to start immediately, click the **Restart Counter Now** button.

- In the Traffic Control section, specify whether a warning message is issued before the monthly traffic limit of MB or hours is reached.

By default, the value is **0** and no warning message is issued. You can select one of the following to occur when the traffic limit is reached:

- The Internet LED blinks green or amber.
- The Internet connection is disconnected and disabled.

- Click the **Apply** button.

Your changes are saved.

➤ **To continue monitoring Internet traffic after the initial setup:**

- Launch a web browser from a computer or WiFi device that is connected to the network.
- Enter **http://www.routerlogin.net** or **http://www.routerlogin.com**.

A login screen displays.

- Enter the router user name and password.

The user name is **admin**. The default password is **password**. The user name and password are case-sensitive.

The BASIC Home screen displays.

- Select **ADVANCED > Advanced Setup > Traffic Meter**.

The screenshot shows the router's web interface with the 'ADVANCED' tab selected. The left sidebar contains a navigation menu with 'Traffic Meter' highlighted. The main content area is titled 'Traffic Meter' and includes the following sections:

- Internet Traffic Meter:**
 - Enable Traffic Meter
 - Traffic volume control by: **No limit** (dropdown menu)
 - Monthly limit: (Mbytes)
 - Round up data volume for each connection by: (Mbytes)
 - Connection time control
 - Monthly limit: (Hours)
- Traffic Counter:**
 - Restart traffic counter at : On the day of each month
 -
- Traffic Control:**
 - Pop up a warning message: Mbytes/Minutes before the monthly limit is reached
 - When the monthly limit is reached:
 - Turn the Internet LED to flashing green/amber
 - Disconnect and disable the Internet connection

At the top of the page, there are 'Cancel' and 'Apply' buttons. The bottom of the page includes a 'Help Center' link and a 'Show/Hide Help Center' button.

5. In the Internet Traffic Statistics section, monitor the data traffic.

The screenshot shows the 'Internet Traffic Statistics' section of the router's web interface. It includes a table with the following data:

| Period | Connection Time (h:mm) | Traffic Volume (Mbytes) | | |
|------------|------------------------|-------------------------|--------------|-----------|
| | | Upload/Avg | Download/Avg | Total/Avg |
| Today | --- | 0.00 | 0.00 | 0.00 |
| Yesterday | --- | 0.00 | 0.00 | 0.00 |
| This week | --- | 0.00/0.00 | 0.00/0.00 | 0.00/0.00 |
| This month | --- | 0.00/0.00 | 0.00/0.00 | 0.00/0.00 |
| Last month | --- | 0.00/0.00 | 0.00/0.00 | 0.00/0.00 |

- To update the Traffic Statistics section, click the **Refresh** button.
- To display more information about the data traffic on your router and to change the poll interval, click the **Traffic Status** button.

The 'Traffic Status' dialog box displays the following information:

- Counting Period: 3/31 days
- Amount Used: 0.00/0.00 Mbytes
- Poll Interval: 10 (secs)

Reboot the Router

➤ To reboot the router:

1. Launch a web browser from a computer or WiFi device that is connected to the network.
2. Enter <http://www.routerlogin.net> or <http://www.routerlogin.com>.

A login screen displays.

3. Enter the router user name and password.

The user name is **admin**. The default password is **password**. The user name and password are case-sensitive.

The BASIC Home screen displays.

4. Click the **ADVANCED** tab.

5. In the Router Information pane, click the **Reboot** button.
6. Click **OK** to confirm.

The router reboots.



WARNING:

Do not interrupt the reboot process.

Remote Management

You can upgrade or check the status of your router over the Internet.

Note: Before you enable remote management, be sure to change the router's default login password to a secure password. The ideal password contains no dictionary words from any language and contains uppercase and lowercase letters, numbers, and symbols. It can be up to 30 characters.

➤ **To set up remote management:**

1. Launch a web browser from a computer or WiFi device that is connected to the network.
2. Enter **http://www.routerlogin.net** or **http://www.routerlogin.com**.

A login screen displays.

3. Enter the router user name and password.

The user name is **admin**. The default password is **password**. The user name and password are case-sensitive.

The BASIC Home screen displays.

4. Select **ADVANCED > Advanced Setup > Remote Management**.

The screenshot shows the 'Remote Management' configuration page. The 'Turn Remote Management On' checkbox is currently unchecked. The 'Remote Management Address' is set to 'https://192.168.0.10:8443'. Under 'Allow Remote Access By', the 'Everyone' radio button is selected. The 'Port Number' is set to 8443. The sidebar on the left shows the navigation menu with 'Remote Management' highlighted.

5. Select the **Turn Remote Management On** check box.
6. Under Allow Remote Access By, specify the external IP addresses that the router's remote management allows.

Note: For enhanced security, restrict access to as few external IP addresses as practical.

7. Select one of the following:
 - **Only This Computer.** Select this radio button to allow access from a single IP address on the Internet. Enter the IP address that is allowed access.
 - **IP Address Range.** Select this radio button to allow access from a range of IP addresses on the Internet. To define the allowed range, enter a beginning and ending IP address.
 - **Everyone.** Select this radio button to allow access from any IP address on the Internet.
8. Specify the port number for accessing the router user interface.

Normal web browser access uses the standard HTTP service port 80. For greater security, enter a custom port number for the remote router user interface. Choose a number from 1024 through 65535, but do not use the number of any common service port. The default is 8080, which is a common alternate for HTTP.

9. Click the **Apply** button.

When you access your router from the Internet, type your router's WAN IP address in your browser's address or location field followed by a colon (:) and the custom port number. For example, if your external address is 203.0.113.123 and you use port number 8080, enter **http://203.0.113.123:8080** in your browser.

Configure FastLane Settings

FastLane lets you reserve bandwidth when you are connecting from a trusted IP address and gives you guaranteed bandwidth for video streaming applications. You can also specify whether the WPS/FastLane button on the router is used for WPS or FastLane.

You can do the following:

- Turn the FastLane feature on and off. (FastLane is set to off by default.)
- Specify the IP address of the trusted computer.
- Set the WPS/FastLane button on your router to WPS or FastLane. (This button is set to WPS by default.)

Enable FastLane

➤ To enable FastLane:

1. Launch a web browser from a computer or WiFi device that is connected to the network.
2. Enter **http://www.routerlogin.net** or **http://www.routerlogin.com**.

A login screen displays.

3. Enter the router user name and password.

The user name is **admin**. The default password is **password**. The user name and password are case-sensitive.

The BASIC Home screen displays.

4. Select **BASIC > FastLane**.

5. Select the **Turn On FastLane** check box.
6. In the **Trusted IP Address** field, enter the IP address of the trusted computer.

When you connect to the router from the trusted IP address, you have guaranteed bandwidth for video streaming applications.

7. Click the **Apply** button.

FastLane is enabled.

Configure the WPS/FastLane button

You can set the WPS/FastLane button to be used as a WPS or a FastLane button. The WPS/FastLane button is set to WPS by default.

➤ **To specify the WPS/FastLane button for WPS or FastLane:**

1. Launch a web browser from a computer or WiFi device that is connected to the network.
2. Enter **http://www.routerlogin.net** or **http://www.routerlogin.com**.

A login screen displays.

3. Enter the router user name and password.

The user name is **admin**. The default password is **password**. The user name and password are case-sensitive.

The BASIC Home screen displays.

4. Select **BASIC > FastLane**.
5. Select the **WPS** or **FastLane** radio button.
6. Click the **Apply** button.

Your changes are saved.

Share USB Devices Attached to the Router

7

This chapter describes how to use the USB port on your router to enhance your local network.

The chapter contains the following sections:

- *USB Device Requirements*
- *Access a USB Device on the Network*
- *Safely Remove a USB Device*
- *View or Configure a USB Device*
- *Access Your USB Device Remotely*
- *Set Up a Network Printer*
- *Common Uses of Network Sharing*

USB Device Requirements

The router works with most USB-compliant external flash and hard drives. If your USB device requires nonstandard drivers, it is not compatible. For the most up-to-date list of USB devices supported by the router, visit <http://kbserver.netgear.com/readysware>.

Some USB external hard drives and flash drives require you to load the drivers onto the computer before the computer can access the USB device. Such USB devices do not work with the router.

The router supports the following file system types for full read/write access:

- FAT16
- FAT32
- NTFS
- NTFS with compression format enabled
- Linux file systems (EXT2, EXT3, EXT4)

Access a USB Device on the Network

ReadySHARE lets you access and share a USB device connected to the router USB port. (If your USB device has special drivers, it is not compatible.)



➤ **To access the USB device from a Mac:**

1. Insert your USB device into the USB port of the router.

If your USB device has a power supply, you must use it when you connect the USB device to the router.

When you connect the USB device to the router USB port, it might take up to two minutes before it is ready for sharing. By default, the USB device is available to all computers on your local area network (LAN).

2. Select **Go > Connect to Server**.
3. Enter **smb://readyshare** as the server address.
4. Click the **Connect** button.

➤ **To access the USB device from a Windows computer:**

1. Insert your USB device into the USB port of the router.

If your USB device has a power supply, you must use it when you connect the USB device to the router.

When you connect the USB device to the router USB port, it might take up to two minutes before it is ready for sharing. By default, the USB device is available to all computers on your local area network (LAN).

2. Select **Start > Run**.
3. Enter **\\readyshare** in the dialog box and click the **OK** button.

➤ **To map the USB device to a local Windows network drive:**

1. Visit www.netgear.com/readyshare.
2. In the ReadySHARE USB Storage Access pane, click the **PC Utility** button.

The `readyshareconnect.exe` file is downloaded to your computer.

3. Launch `readyshareconnect.exe`.

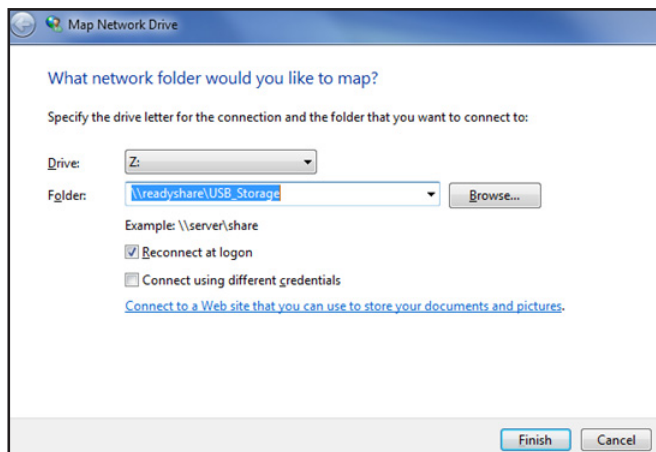

4. Select the drive letter that you want to map to the network folder.

5. If you want to connect to the USB device as a different user, select the **Connect using different credentials** check box.
 - a. Type the user name and password that you want to use.
 - b. Click the **OK** button.
6. Click the **Finish** button.

The USB device is mapped to the drive letter that you specified.

Safely Remove a USB Device

Before you physically disconnect a USB device from the router USB port, log in to the router and take the USB device offline.

➤ **To remove a USB device safely:**

1. Launch a web browser from a computer or WiFi device that is connected to the network.
2. Enter **http://www.routerlogin.net** or **http://www.routerlogin.com**.

A login screen displays.

3. Enter the router user name and password.

The user name is **admin**. The default password is **password**. The user name and password are case-sensitive.

The BASIC Home screen displays.

4. Select **ReadySHARE**.

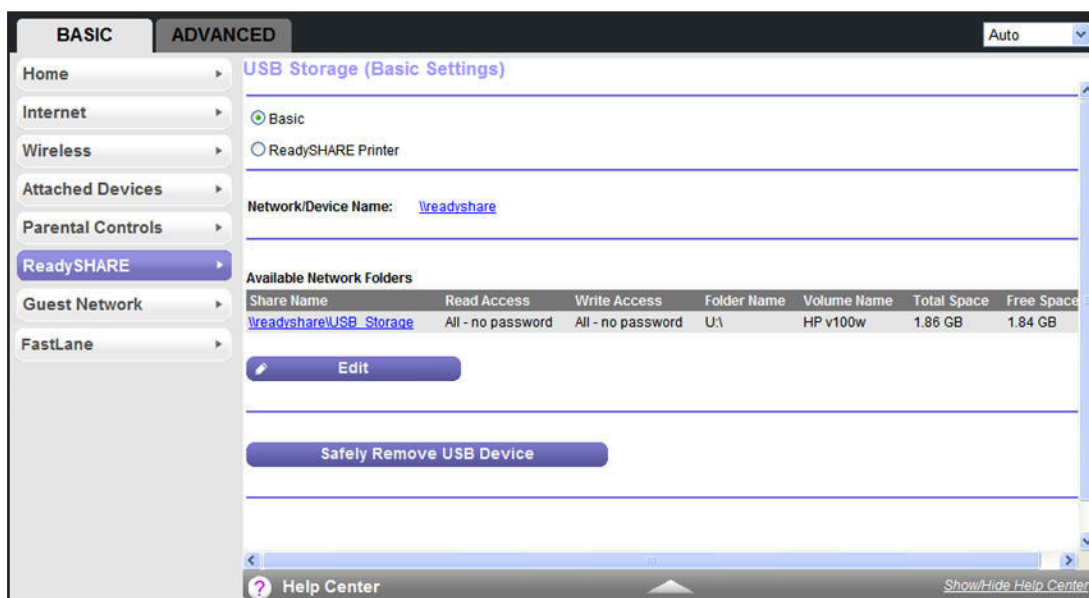

5. Click the **Safely Remove USB Device** button.

This action takes the device offline.

6. Physically disconnect the USB device.

View or Configure a USB Device

You can use your USB device in the following ways:

- View the basic information about the device.
- Set up the device name, workgroups, and network folders.
- View or change the network folders.
- For more security, share only approved USB devices.

➤ To view basic information about the USB device:

1. Launch a web browser from a computer or WiFi device that is connected to the network.
2. Enter **http://www.routerlogin.net** or **http://www.routerlogin.com**.

A login screen displays.

3. Enter the router user name and password.

The user name is **admin**. The default password is **password**. The user name and password are case-sensitive.

The BASIC Home screen displays.

4. Select **ReadySHARE**.

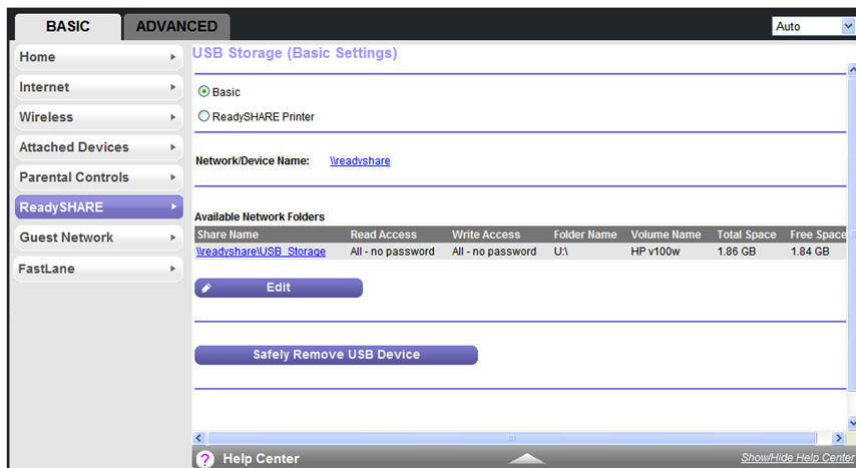

The screen displays a USB storage device if it is attached to the router USB port.

If you logged in to the router before you connected your USB device, you might not see your USB device in this screen. If this happens, log out and log back in.

5. To view the files and folders on the USB device, click the network device name or the share name.
6. To view more detail or to change the USB device settings, click the **Edit** button.

The USB Storage (Advanced Settings) screen displays. For more information, see *Configure the USB Storage Device and Access Settings* on page 104.

Configure the USB Storage Device and Access Settings

You can set up the device name, workgroups, and network folders for your USB device.

➤ **To view or change the USB storage advanced settings:**

1. Launch a web browser from a computer or WiFi device that is connected to the network.
2. Enter **http://www.routerlogin.net** or **http://www.routerlogin.com**.

A login screen displays.

3. Enter the router user name and password.

The user name is **admin**. The default password is **password**. The user name and password are case-sensitive.

The BASIC Home screen displays.

4. Select **ReadySHARE**.

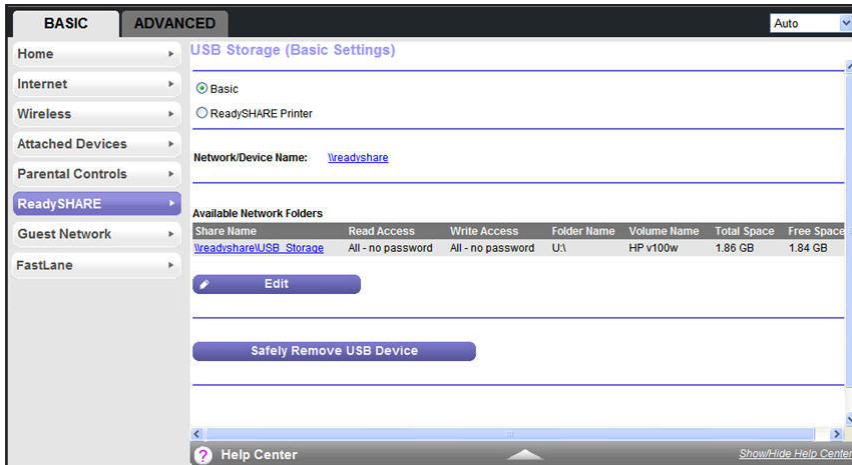

5. Click the **Edit** button.

USB Storage (Advanced Settings)

Refresh Apply

Network Device Name: readyshare

Workgroup: Workgroup

| Enable | Access Method | Link | Port |
|-------------------------------------|-------------------------------|--|------|
| <input checked="" type="checkbox"/> | Network Neighborhood/MacShare | \\readyshare | - |
| <input checked="" type="checkbox"/> | HTTP | http://readyshare.routerlogin.net/shares | 80 |
| <input type="checkbox"/> | HTTPS (via internet) | https://192.168.0.7:443/shares | 443 |
| <input type="checkbox"/> | FTP | ftp://readyshare.routerlogin.net/shares | 21 |
| <input type="checkbox"/> | FTP (via internet) | ftp://192.168.0.7:21/shares | 21 |

Available Network Folders

| Share Name | Read Access | Write Access | Folder Name | Volume Name | Total Space | Free Space |
|------------|-------------|--------------|-------------|-------------|-------------|------------|
| | | | | | | |

Edit + Create Network Folder × Delete

Safely Remove USB Device

6. To specify access to the USB storage device, provide the following information:

- **Network Device Name.** The default is **readyshare**. This name is the name used to access the USB device connected to the router.
- **Workgroup.** If you are using a Windows workgroup rather than a domain, the workgroup name displays here. The name works only in an operating system that supports NetBIOS, such as Microsoft Windows.
- **Access Method.** Select the access methods:
 - **Network Neighborhood/MacShare.** Enabled by default.
 - **HTTP.** Enabled by default. You can type **http://readyshare.routerlogin.net/shares** to access the USB device.
 - **HTTP (via Internet).** Disabled by default. If you enable this feature, remote users can type **http://<public IP address/shares>** (for example, **http://1.1.10.102/shares**) or a URL domain name to access the USB device over the Internet. This feature supports file uploading only.
 - **FTP.** Disabled by default.
 - **FTP (via Internet).** Disabled by default. If you select this check box, remote users can access the USB device through FTP over the Internet. This feature supports both downloading and uploading of files.

7. If you changed the settings, click the **Apply** button.

Your changes are saved.

Configure the Available Network Folders

You can view or change the network folders on the USB storage device.

➤ **To view network folders:**

1. Launch a web browser from a computer or WiFi device that is connected to the network.
2. Enter **http://www.routerlogin.net** or **http://www.routerlogin.com**.

A login screen displays.

3. Enter the router user name and password.

The user name is **admin**. The default password is **password**. The user name and password are case-sensitive.

The BASIC Home screen displays.

4. Select **ReadySHARE**.

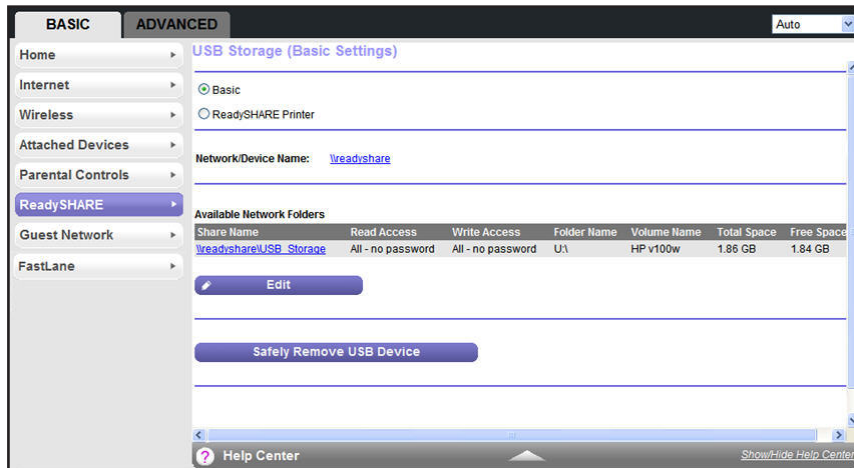

5. Click the **Edit** button.

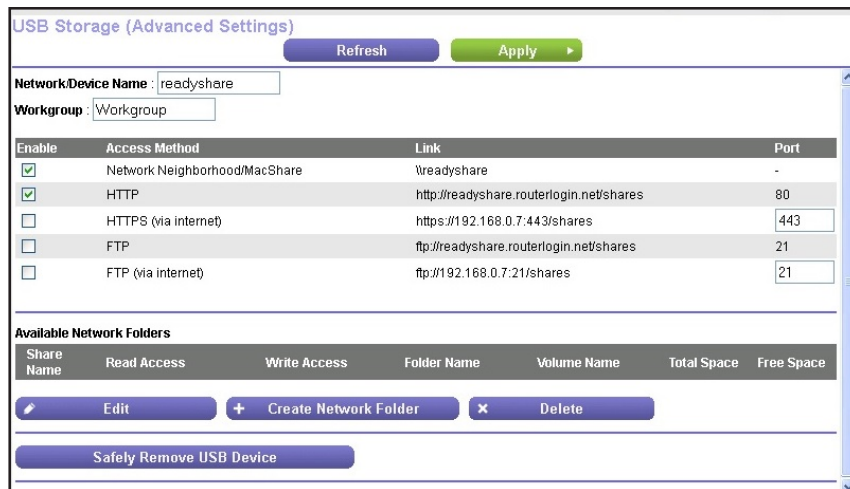

6. Scroll down to the Available Networks Folder section of the screen. The following information displays:

- **Share Name.** If only one device is connected, the default share name is USB_Storage. (Some router models have more than one USB port.)

You can click the name or you can type it in the address field of your web browser. If Not Shared is shown, the default share was deleted and no other share for the root folder exists. Click the link to change this setting.

- **Read Access and Write Access.** Show the permissions and access controls on the network folder. All – no password (the default) allows all users to access the network folder. The password for admin is the same one that you use to log in to the router.
- **Folder Name.** Full path of the network folder.
- **Volume Name.** Volume name from the storage device (either USB device or HDD).
- **Total Space and Free Space.** Show the current utilization of the storage device.

➤ **To add a network folder:**

1. Launch a web browser from a computer or WiFi device that is connected to the network.
2. Enter **http://www.routerlogin.net** or **http://www.routerlogin.com**.

A login screen displays.

3. Enter the router user name and password.

The user name is **admin**. The default password is **password**. The user name and password are case-sensitive.

The BASIC Home screen displays.

4. Select **ReadySHARE**.

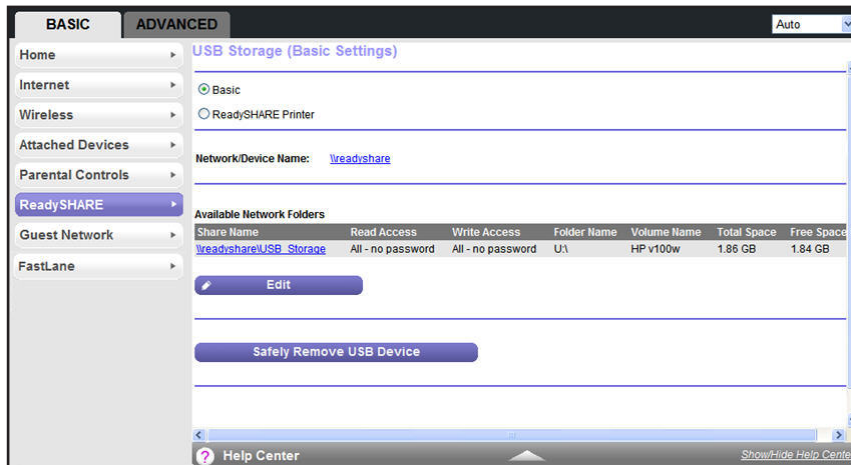

5. Click the **Edit** button.

USB Storage (Advanced Settings)

Refresh Apply

Network Device Name: readyshare

Workgroup: Workgroup

| Enable | Access Method | Link | Port |
|-------------------------------------|-------------------------------|--|------|
| <input checked="" type="checkbox"/> | Network Neighborhood/MacShare | \\readyshare | - |
| <input checked="" type="checkbox"/> | HTTP | http://readyshare.routerlogin.net/shares | 80 |
| <input type="checkbox"/> | HTTPS (via internet) | https://192.168.0.7:443/shares | 443 |
| <input type="checkbox"/> | FTP | ftp://readyshare.routerlogin.net/shares | 21 |
| <input type="checkbox"/> | FTP (via internet) | ftp://192.168.0.7:21/shares | 21 |

Available Network Folders

| Share Name | Read Access | Write Access | Folder Name | Volume Name | Total Space | Free Space |
|--|-------------|--------------|-------------|-------------|-------------|------------|
| <p>Edit + Create Network Folder × Delete</p> <p>Safely Remove USB Device</p> | | | | | | |

6. Click the **Create Network Folder** button.

http://www.routerlogin.net/USB_Folder_creat.htm

Create Network Folder

USB Device: U:U Drive (1.96 GB)

Folder: [Browse]

Share Name: []

Read Access: All - no password

Write Access: All - no password

Apply

Close Window

If the Create a Network Folder screen does not display, your web browser might be blocking pop-ups. If it is, change the browser settings to allow pop-ups.

7. Click the **Browse** button next to the **Folder** field, and select the folder.
8. In the **Share Name** field enter a name.
9. In the **Read Access** list and the **Write Access** list, select the settings that you want.

The user name (account name) for All – no password is guest. The password for admin is the same one that is used to log in to the router. By default, it is password.

10. Click the **Apply** button.

The folder is added on the USB device.

➤ **To edit a network folder:**

1. Launch a web browser from a computer or WiFi device that is connected to the network.
2. Enter **http://www.routerlogin.net** or **http://www.routerlogin.com**.
A login screen displays.
3. Enter the router user name and password.

The user name is **admin**. The default password is **password**. The user name and password are case-sensitive.

The BASIC Home screen displays.

4. Select **ReadySHARE**.

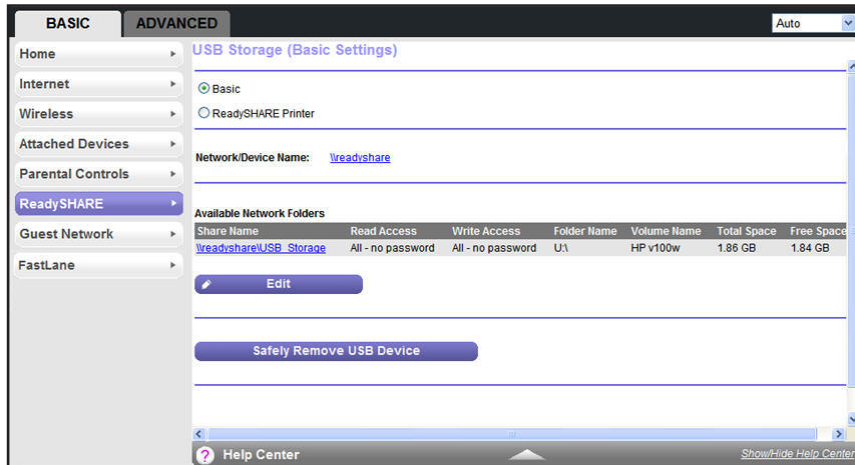

5. Click the **Edit** button.

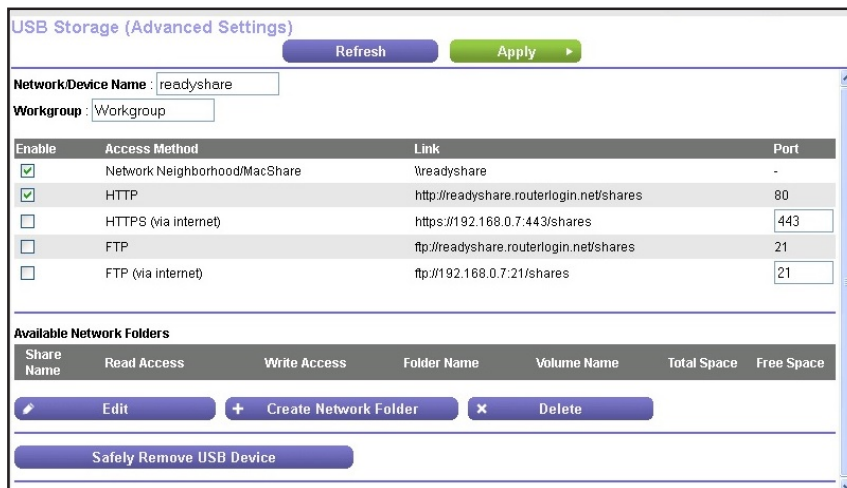

6. Click the **Edit** button.

The Edit Network Folder screen displays the same settings shown in the Create a Network Folder screen.

7. Change the settings in the fields as needed.

8. Click the **Apply** button.

Your changes are saved.

Specify Approved USB Devices

For more security, you can set up the router to share only approved USB devices.

➤ **To set up approved USB devices:**

1. Launch a web browser from a computer or WiFi device that is connected to the network.
2. Enter **http://www.routerlogin.net** or **http://www.routerlogin.com**.

A login screen displays.

3. Enter the router user name and password.

The user name is **admin**. The default password is **password**. The user name and password are case-sensitive.

The BASIC Home screen displays.

4. Select **ADVANCED > Advanced Setup > USB Settings**.

5. Click the **Approved Devices** button.

| Approved USB Devices | | | |
|----------------------|-------------|-------------|----------|
| | Volume Name | Device Name | Capacity |
| Delete | | | |

| Available USB Devices | | | |
|-----------------------|-------------|-------------|----------|
| | Volume Name | Device Name | Capacity |
| ○ | HP v100w | HP v100w | 1.86 GB |

This screen shows the approved USB devices and the available USB devices.

6. In the Available USB Devices list, select the drive that you want to approve.
7. Click the **Add** button.
8. Select the **Allow only approved devices** check box.
9. Click the **Apply** button.

Your change takes effect.

If you want to work with another USB device, first click the **Safely Remove USB Device** button for the currently connected USB device and physically remove the device. Connect the other USB device and repeat this process. For more information, see [Safely Remove a USB Device](#) on page 102.

Access Your USB Device Remotely

When you connect the USB device to the router USB port, it might take up to two minutes before it is ready for sharing. You can access your USB storage device remotely.

➤ **To access the USB device from a remote computer:**

1. Launch a web browser.
2. Connect using the router's Internet port IP address.

If you are using Dynamic DNS, you can type the DNS name rather than the IP address. You can view the router's Internet IP address on the ADVANCED Home screen.

➤ **To access the USB device with FTP from a remote computer:**

1. Launch a web browser from a computer or WiFi device that is connected to the network.
2. Enter **http://www.routerlogin.net** or **http://www.routerlogin.com**.

A login screen displays.

3. Enter the router user name and password.

The user name is **admin**. The default password is **password**. The user name and password are case-sensitive.

The BASIC Home screen displays.

4. Select **ReadySHARE**.

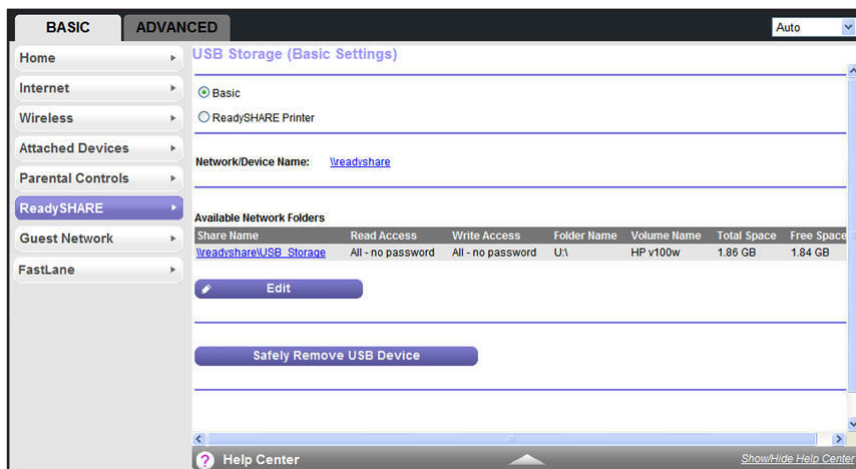

5. Click the **Edit** button.

USB Storage (Advanced Settings)

Refresh Apply

Network/Device Name: readyshare

Workgroup: Workgroup

| Enable | Access Method | Link | Port |
|-------------------------------------|-------------------------------|--|------|
| <input checked="" type="checkbox"/> | Network Neighborhood/MacShare | \\readyshare | - |
| <input checked="" type="checkbox"/> | HTTP | http://readyshare.routerlogin.net/shares | 80 |
| <input type="checkbox"/> | HTTPS (via internet) | https://192.168.0.7:443/shares | 443 |
| <input type="checkbox"/> | FTP | ftp://readyshare.routerlogin.net/shares | 21 |
| <input type="checkbox"/> | FTP (via internet) | ftp://192.168.0.7:21/shares | 21 |

Available Network Folders

| Share Name | Read Access | Write Access | Folder Name | Volume Name | Total Space | Free Space |
|------------|-------------|--------------|-------------|-------------|-------------|------------|
| | | | | | | |

Edit + Create Network Folder x Delete

Safely Remove USB Device

6. Select the **FTP** check box.

For more information, see *Configure the USB Storage Device and Access Settings* on page 104.

7. Launch a web browser.

8. Type **ftp://** and the Internet port IP address in the address field of the browser.

For example, type **ftp://10.1.65.4**.

If you are using Dynamic DNS, you can type the DNS name rather than the IP address.

9. Type the account name and password for the account that has access rights to the USB device.

The user name (account name) for All – no password is **guest**.

The directories of the USB device that your account has access to display. For example, you could see `share/partition1/directory1`. You can now read and copy files from the USB directory.

➤ **To access the USB device with ReadySHARE access from the Internet:**

You can access your USB device in any of the following ways:

- On Windows 7, Windows 8, Windows XP, Windows Vista, and Windows 2000 systems, select **Start > Run**, and enter **\\readyshare** in the dialog box. Click the **OK** button.
- On Windows 7, Windows 8, Windows XP, Windows Vista, and Windows 2000 systems, open Internet Explorer, or Safari, and enter **\\readyshare** in the address bar.
- On Mac OS X (version 10.2 or later), enter **smb://readyshare** in the address bar.
- In My Network Places, enter **\\readyshare** in the address bar.

For more information about ReadySHARE access for USB storage devices, visit <http://www.netgear.com/readyshare>.

Set Up a Network Printer

The ReadySHARE Printer utility allows you to control from your computer a shared USB printer that is connected to the USB port on your router. You can share this USB printer among the Windows and Mac computers on your network.

You must install this utility before you can use the ReadySHARE Printer feature. For this feature to work, the following conditions must be met:

- This utility must be installed and running in the background on each computer from which you want to control this USB printer.
- The driver software for the USB printer must be installed on each computer from which you want to control this USB printer.

The ReadySHARE Printer utility has both a Mac version and a Windows version. The ReadySHARE Printer utility setup file and instructions are available by visiting www.netgear.com/readysware. After you install the ReadySHARE Printer utility, it displays on your computer as the NETGEAR USB Control Center.

➤ To set up and use ReadySHARE Printer:

1. Using a USB printer cable, connect a USB printer to the router's USB port.

For information about how to locate the USB port, see [Access a USB Device on the Network](#) on page 100.

2. Install the USB printer driver software *on each computer* that shares the printer.

If you do not have the printer driver, contact the printer manufacturer.

3. On each computer that shares the printer, download the NETGEAR USB Control Center utility.

The NETGEAR USB utility has a Mac version and a Windows version, which you can access in two different ways:

- From the ReadySHARE Printer area of the page you access from www.netgear.com/readysware.

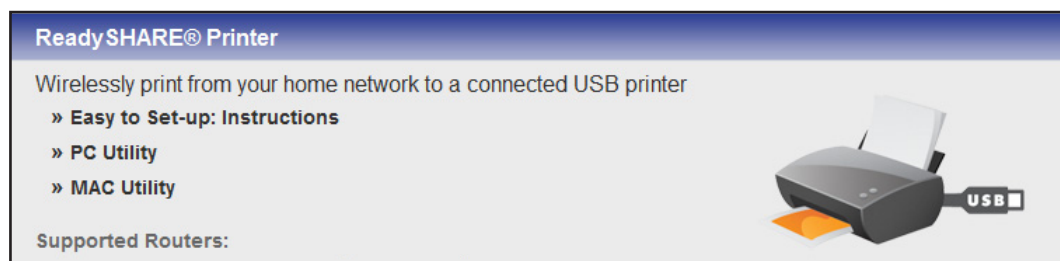

- From the ReadySHARE section of the desktop NETGEAR genie.

For more information, visit www.NETGEAR.com/genie.

Note: You must install this utility before you can use the ReadySHARE Printer feature. For the ReadySHARE Printer feature to work, this utility must be running in the background.

4. Follow the instructions to install the NETGEAR USB Control Center utility.



5. After you install the utility, select the language.



If this setup is the first time you are accessing the utility, you are asked to select the printer.

- Click the **Connect** button.

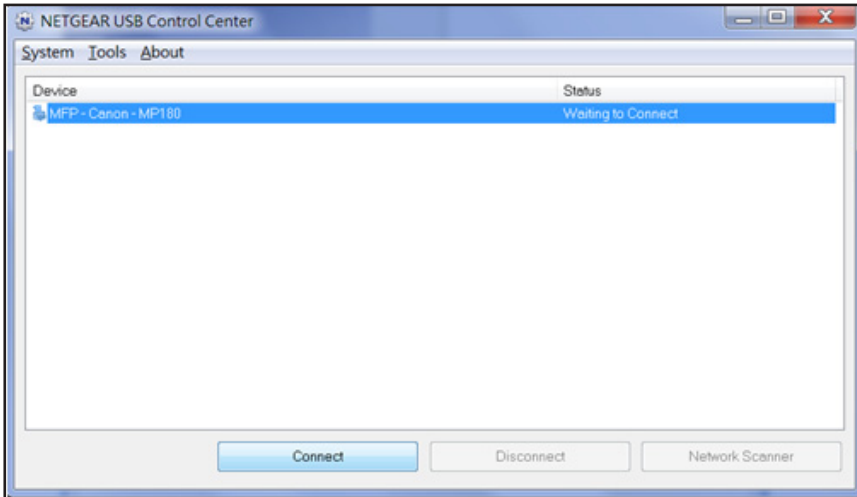

Once the connection is established, the status changes to Manually connected by xxx.

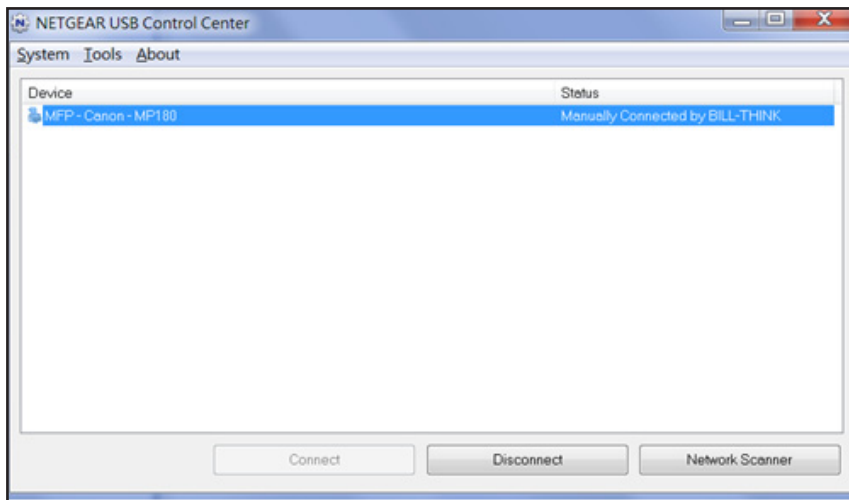

- Click the **Disconnect** button at any time to release the connection.

The status then changes to Available.

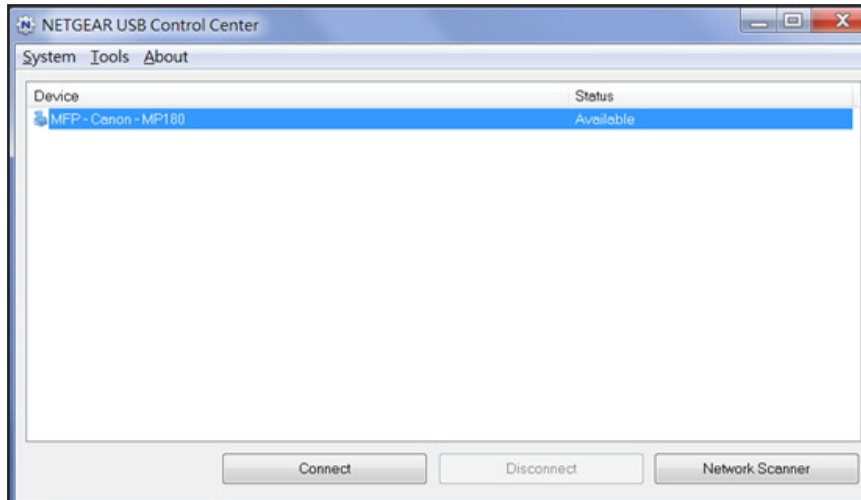

For each computer, after you click the **Connect** and **Disconnect** buttons once, the utility automatically handles the printing queue. The status of the printer displays as Available on all the computers. Here are the rules of operation:

- When the status is Available, you can use the USB printer.
- When the status is Manually connected by xxx, only the xxx computer can use the printer. Other network devices must wait until the xxx computer has released the connection, or until the connection times out (the default time-out value is 30 seconds).
- You can set the value for the default time-out time from the Control Center - Configuration screen.

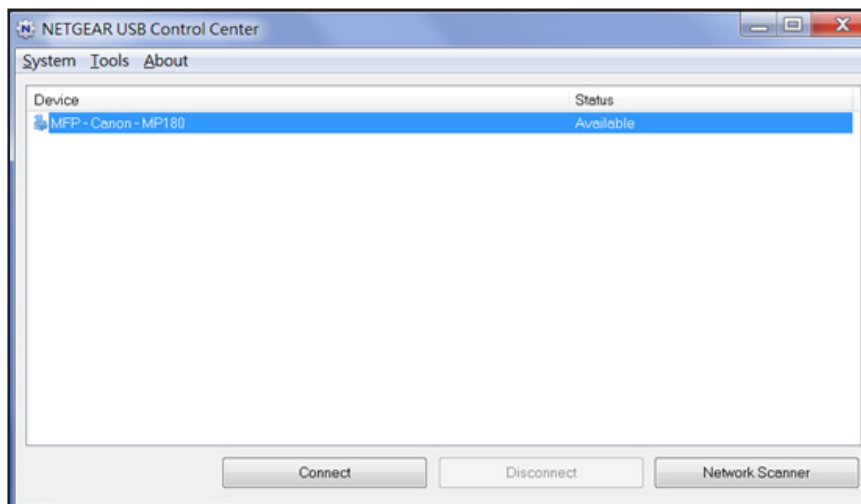

- The USB Control Center utility must be running for the computer to print to the USB printer attached to the router. If you exit the utility, printing does not work.
- Some firewall software, such as Comodo, blocks the ReadySHARE Print utility from accessing the USB printer. If you do not see the printer in the utility, you can disable the firewall temporarily to allow the utility to work.

- If your printer supports scanning, make sure that the printer is in the Available state and click the **Network Scanner** button.

This step activates the scanner window so you can use the printer for scanning.

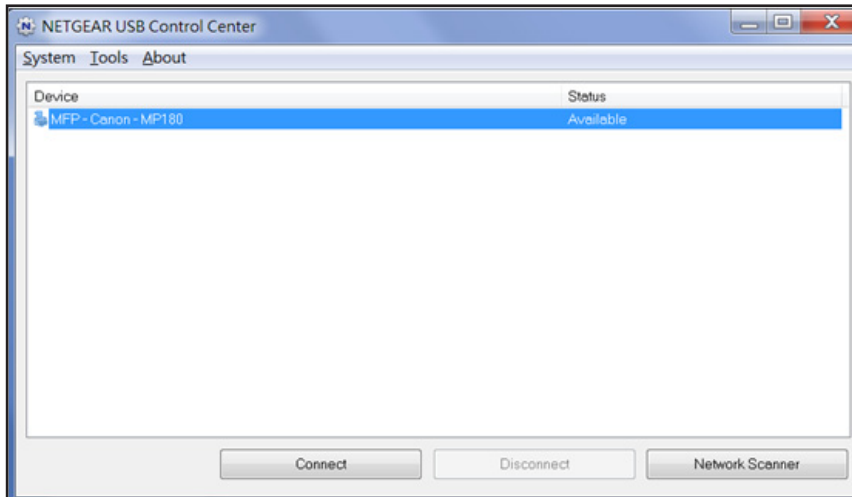

Common Uses of Network Sharing

USB device applications include the following:

- Sharing multimedia such as MP3 files, pictures, and other multimedia with local and remote users.
- Sharing resources on your network. You can store files in a central location so that you do not need to power up a computer to perform local sharing. In addition, you can share files between Macintosh, Linux, and Windows computers by using the USB device as a go-between across the systems.
- Sharing large files such as Word documents, PowerPoint presentations, and text files with remote users.

Share Photos and Multimedia

You can create your own central storage location for photos and multimedia. This method eliminates the need to log in to (and pay for) an external photo-sharing site.

➤ To share photos and multimedia with your friends and family:

1. Insert your USB device into the USB port on the router either directly or with a USB cable.

Computers on your local area network (LAN) can automatically access this USB device using a web browser or Microsoft Networking.

2. If you want to specify read-only access or to allow access from the Internet, see *Configure the USB Storage Device and Access Settings* on page 104.

Print High-Quality Photos from a Nonshared Printer

You can print high-quality photos from a non-shared printer. The following scenario is for a family that does not have a print server:

- A family member has photos on a Macintosh computer and wants to print them.
- The photo-capable color printer is directly attached to a Windows computer, but not shared on the network.
- The Mac and the Windows computer are not visible to each other on the network.

➤ **To print high-quality photos from a nonshared printer using a Mac:**

Access the USB device by typing `\\readyshare` in the address field of a web browser. Then copy the photos to the USB device.

You can also set up a network printer. For more information, see [Set Up a Network Printer](#) on page 113.

➤ **To print high-quality photos from a non-shared printer using a Window computer:**

On a Window computer, use a web browser or Microsoft Networking to copy the files from the USB device to the computer. Then print the files.

You can also set up a network printer. For more information, see [Set Up a Network Printer](#) on page 113.

Send Large Files over the Internet

Sending files that are larger than 5 MB can pose a problem for many email systems. The router allows you to share large files such as PowerPoint presentations or .zip files over the Internet. You can use FTP to download shared files from the router.

Sharing files with a remote colleague involves the following considerations:

- The two user accounts are admin and guest. The password for admin is the same one that you use to access the router. By default, it is password. The guest user account has no password.
- On the FTP site, the person receiving the files uses the guest user account and enters the password. FTP requires that you type something in the password field.
- Be sure to select the **FTP (via Internet)** check box in the USB Storage (Advanced Settings) screen. This option supports both downloading and uploading of files.

Note: You can select the **HTTP (via Internet)** check box on the USB Storage (Advanced Settings) screen to share large files. This option supports downloading files only.

For more information, see [Access Your USB Device Remotely](#) on page 111.

Control Access to the Internet

8

The router comes with a built-in firewall that helps protect your home network from unwanted intrusions from the Internet.

This chapter includes the following sections:

- *Set Up Parental Controls*
- *Set Up a Guest Network*
- *Use Keywords to Block Internet Sites*
- *Set Up a Wireless Access List*
- *Block Services from the Internet*
- *Schedule When to Block Internet Sites and Services*
- *Avoid Blocking on a Trusted Computer*
- *Set Up Security Event Email Notifications*

Set Up Parental Controls

The first time that you select **Parental Controls** from the BASIC Home screen, your browser goes to the Live Parental Controls website, where you can learn more about Live Parental Controls and download the application.



➤ To set up Live Parental Controls:

1. Launch a web browser from a computer or WiFi device that is connected to the network.
2. Enter **http://www.routerlogin.net** or **http://www.routerlogin.com**.

A login screen displays.

3. Enter the router user name and password.

The user name is **admin**. The default password is **password**. The user name and password are case-sensitive.

The BASIC Home screen displays.

4. Select **Parental Controls**.
5. Click either the **Windows Users** or **Mac Users** button.
6. Follow the onscreen instructions to download and install the NETGEAR Live Parental Controls management utility.

After installation, Live Parental Controls automatically starts.

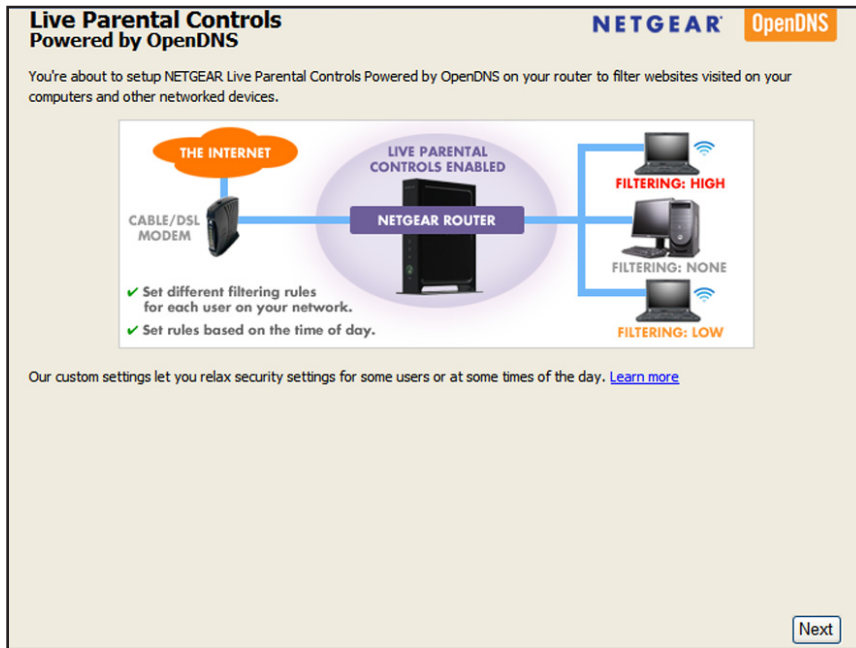

7. Click the **Next** button.
8. Read the note, and click the **Next** button again to proceed.

Because Live Parental Controls uses free OpenDNS accounts, you are prompted to log in or create a free account.

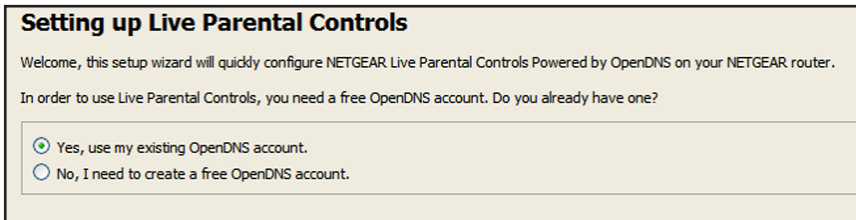

9. Select the radio button that applies to you:
 - If you already have an OpenDNS account, leave the **Yes** radio button selected.
 - If you do not have an OpenDNS account, select the **No** radio button.
10. Click the **Next** button.

If you are creating an account, the following screen displays:

11. Complete the fields and click the **Next** button.

After you log on or create your account, the filtering level screen displays:

Live Parental Controls: choose a filtering level for your network

All computers connected to your router will be protected from the content you select below. You can customize your Live Parental Controls later on our website.

High
Protects against all adult-related sites, illegal activity, social networking sites, video sharing sites, phishing attacks and general time-wasters.

Moderate
Protects against all adult-related sites, illegal activity and phishing attacks.

Low
Protects against pornography and phishing attacks.

Minimal
Protects only against phishing attacks.

None
Nothing blocked.

12. Select a radio button for a filtering level and click the **Next** button.

Setup is complete!

You have successfully setup NETGEAR Live Parental Controls Powered by OpenDNS. Next time you run the Management Utility it will take you to the status screen where you can:

- check whether Live Parental Controls are enabled
- disable or enable Live Parental Controls
- modify basic settings
- change custom settings such as per-user and time-of-day based Live Parental Controls

13. Click the **Take me to the status screen** button.

Parental controls are now set up for the router. The dashboard shows Parental Controls as Enabled.

Set Up a Guest Network

A guest network allows visitors at your home to use the Internet without using your wireless security key. You can add a guest network to each wireless network: 2.4 GHz b/g/n and 5.0 GHz a/n.

➤ To set up a guest network:

1. Launch a web browser from a computer or WiFi device that is connected to the network.
2. Enter **http://www.routerlogin.net** or **http://www.routerlogin.com**.
A login screen displays.
3. Enter the router user name and password.

The user name is **admin**. The default password is **password**. The user name and password are case-sensitive.

The BASIC Home screen displays.

4. Select **Guest Network**.

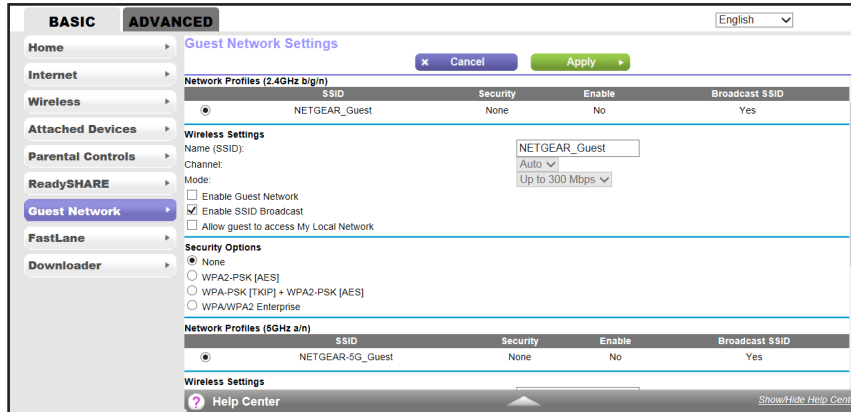

5. Select any of the following wireless settings:

- **Enable Guest Network.** When this check box is selected, the guest network is enabled, and guests can connect to your network using the SSID of this profile.
- **Enable SSID Broadcast.** If this check box is selected, the wireless access point broadcasts its name (SSID) to all wireless stations. Stations with no SSID can adopt the correct SSID for connections to this access point.
- **Allow guest to see each other and access my local network.** If this check box is selected, anyone who connects to this SSID has access to your local network, not just Internet access.

6. Give the guest network a name in the **Name (SSID)** field.

The guest network name is case-sensitive and can be up to 32 characters. You then manually configure the WiFi devices in your network to use the guest network name in addition to the main SSID.

7. Select a security option.

The WPA2 options use the newest standard for the strongest security, but some older computers and WiFi devices cannot use it. NETGEAR recommends that you select the **WPA-PSK [TKIP] + WPA2-PSK [AES]** radio button. This setting protects your WiFi network and lets computers and WiFi devices can connect to the WiFi network by using either WPA2 or WPA security.

8. Click the **Apply** button.

Your settings are saved.

Use Keywords to Block Internet Sites

You can use keywords to block certain Internet sites from your network. You can use blocking continuously or based on a schedule.

➤ **To configure keyword blocking:**

1. Launch a web browser from a computer or WiFi device that is connected to the network.
2. Enter **http://www.routerlogin.net** or **http://www.routerlogin.com**.

A login screen displays.

3. Enter the router user name and password.

The user name is **admin**. The default password is **password**. The user name and password are case-sensitive.

The BASIC Home screen displays.

4. Select **ADVANCED > Security > Block Sites**.

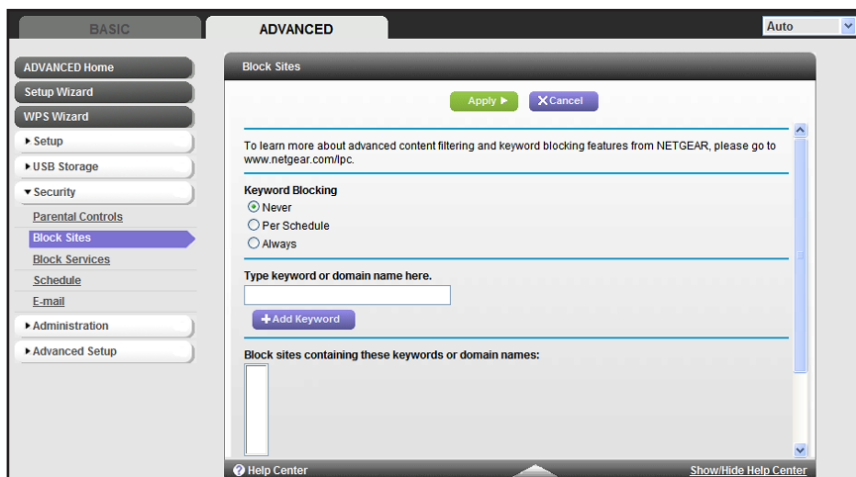

5. Select one of the keyword blocking options:

- **Per Schedule.** Turn on keyword blocking according to the Schedule screen settings. (See *Schedule When to Block Internet Sites and Services* on page 129.)
- **Always.** Turn on keyword blocking all the time, independent of the Schedule screen.

6. In the **keyword** field, enter a keyword or domain that you want to block.

For example:

- Specify XXX to block <http://www.badstuff.com/xxx.html>.
- Specify .com if you want to allow only sites with domain suffixes such as .edu or .gov.
- Enter a period (.) to block all Internet browsing access.

7. Click the **Add Keyword** button.

The keyword is added to the keyword list. The keyword list supports up to 32 entries.

8. Click the **Apply** button.

Keyword blocking takes effect.

➤ **To delete keywords from the list:**

1. Launch a web browser from a computer or WiFi device that is connected to the network.

2. Enter **http://www.routerlogin.net** or **http://www.routerlogin.com**.

A login screen displays.

3. Enter the router user name and password.

The user name is **admin**. The default password is **password**. The user name and password are case-sensitive.

The BASIC Home screen displays.

4. Select **ADVANCED > Security > Block Sites**.

5. Do one of the following:

- To delete a single word, select it and click the **Delete Keyword** button.

The keyword is removed from the list.

- To delete all keywords on the list, click the **Clear List** button.

All keywords are removed from the list.

6. Click the **Apply** button.

Your changes are saved.

➤ **To specify a trusted computer:**

1. Launch a web browser from a computer or WiFi device that is connected to the network.

2. Enter **http://www.routerlogin.net** or **http://www.routerlogin.com**.

A login screen displays.

3. Enter the router user name and password.

The user name is **admin**. The default password is **password**. The user name and password are case-sensitive.

The BASIC Home screen displays.

4. Select **ADVANCED > Security > Block Sites**.

5. In the **Trusted IP Address** field, enter the IP address.

6. Click the **Apply** button.

Your settings are saved.

Set Up a Wireless Access List

You can set up a list of computers and WiFi devices that are allowed to use WiFi to connect to the router. You must enter the MAC address of each computer or device. When you enable access control, computers and devices that are not in the list cannot connect with WiFi.

➤ **To set up a wireless access list and turn on access control:**

1. Launch a web browser from a computer or WiFi device that is connected to the network.

- Enter **http://www.routerlogin.net** or **http://www.routerlogin.com**.

A login screen displays.

- Enter the router user name and password.

The user name is **admin**. The default password is **password**. The user name and password are case-sensitive.

The BASIC Home screen displays.

- Select **ADVANCED > Advanced Setup > Wireless Settings**.

- Click the **Set Up Access List** button.

- Click the **Add** button.

The screen adjusts.

| # | Device Name | MAC Address |
|---|---------------|-------------------|
| 1 | MPAWLAN-SPARE | 00:13:02:12:13:3F |

Wireless Card Entry

Device Name:

MAC Address:

- Complete the **Device Name** and **MAC Address** fields.

- Click the **Add** button.

The Wireless Card Access List screen displays with the device that you added in the access list.

- When you have finished adding devices to the access list, select the **Turn Access Control On** check box.

- Click the **Apply** button.

Your changes are saved.

- **To edit a WiFi device or delete it from the access list:**
1. Launch a web browser from a computer or WiFi device that is connected to the network.
 2. Enter **http://www.routerlogin.net** or **http://www.routerlogin.com**.
A login screen displays.
 3. Enter the router user name and password.
The user name is **admin**. The default password is **password**. The user name and password are case-sensitive.
The BASIC Home screen displays.
 4. Select **ADVANCED > Advanced Setup > Wireless Settings**.
The Advanced Wireless Settings screen displays.
 5. In the table, select the radio button next to the WiFi device that you want to edit or delete.
 6. To edit a WiFi device, click the **Edit** button.
 - a. Edit the address information.
 - b. Click the **Accept** button.
Your changes are saved.
 7. To delete a wireless device from the access list, click the **Delete** button.
The address is removed from the table.

Block Services from the Internet

You can block Internet services on your network based on the type of service. You can block the services continuously or based on a schedule.

- **To block services:**
1. Launch a web browser from a computer or WiFi device that is connected to the network.
 2. Enter **http://www.routerlogin.net** or **http://www.routerlogin.com**.
A login screen displays.
 3. Enter the router user name and password.
The user name is **admin**. The default password is **password**. The user name and password are case-sensitive.
The BASIC Home screen displays.

4. Select **ADVANCED** > **Security** > **Block Services**.



5. Specify when to block the services:

- **Always.** Select this radio button to block the services continuously.
- **Per Schedule.** Select this radio button to block the services based on a schedule.

For more information about how to specify the schedule, see [Schedule When to Block Internet Sites and Services](#) on page 129.

6. Click the **Add** button.

The Block Services Setup screen displays:

7. To add a service that is in the **Service Type** list, select the application or service.

The settings for this service automatically display in the fields.

8. To add a service or application that is not the list, select **User Defined**.

- If you know that the application uses either TCP or UDP, select the appropriate protocol; otherwise, select **TCP/UDP (both)**.
- Enter the starting port and ending port numbers.

If the service uses a single port number, enter that number in both fields.

To find out which port numbers the service or application uses, you can contact the publisher of the application, ask user groups or newsgroups, or search on the Internet.

9. Specify how to filter the services:
 - **Only This IP Address.** Block services for a single computer.
 - **IP Address Range.** Block services for a range of computers with consecutive IP addresses on your network.
 - **All IP Addresses.** Block services for all computers on your network.
10. Click the **Add** button.
Your changes are saved.

Schedule When to Block Internet Sites and Services

When you schedule blocking, the same schedule is used to block sites and to block services. For information about how to specify what you want the router to block, see [Use Keywords to Block Internet Sites](#) on page 123 and [Block Services from the Internet](#) on page 127.

➤ To schedule blocking:

1. Launch a web browser from a computer or WiFi device that is connected to the network.
2. Enter <http://www.routerlogin.net> or <http://www.routerlogin.com>.

A login screen displays.

3. Enter the router user name and password.

The user name is **admin**. The default password is **password**. The user name and password are case-sensitive.

The BASIC Home screen displays.

4. Select **ADVANCED > Security > Schedule**.

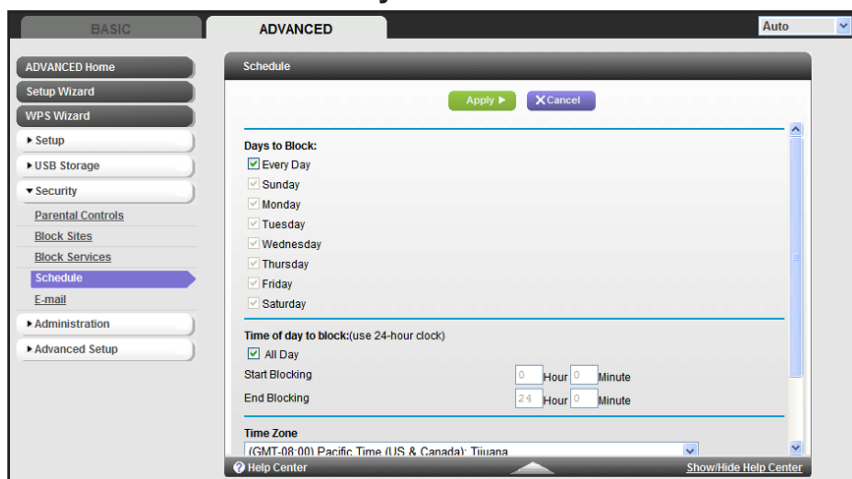

5. Specify when to block keywords and services:
 - **Days to Block.** Select the check box for each day that you want to block the keywords or select the **Every Day** check box, which automatically selects the check boxes for all days.

- **Time of Day to Block.** Select a start and end time in 24-hour format, or select **All Day** for 24-hour blocking.
6. Select your time zone from the list.
 7. If you live in an area that observes daylight saving time, select the **Automatically adjust for daylight savings time** check box.
 8. Click the **Apply** button.
- Your settings are saved.

Avoid Blocking on a Trusted Computer

You can exempt one trusted computer from blocking. The computer you exempt must have a fixed IP address. You can use the reserved IP address feature to specify the IP address. See [Reserve LAN IP Addresses](#) on page 41.

➤ To specify a trusted computer:

1. Launch a web browser from a computer or WiFi device that is connected to the network.
2. Enter **http://www.routerlogin.net** or **http://www.routerlogin.com**.
A login screen displays.
3. Enter the router user name and password.
The user name is **admin**. The default password is **password**. The user name and password are case-sensitive.
The BASIC Home screen displays.
4. Select **ADVANCED > Security > Block Sites**.
5. Scroll down and select the **Allow trusted IP address to visit blocked sites** check box.
6. In the **Trusted IP Address** field, enter the IP address of the trusted computer.
7. Click the **Apply** button.
Your changes are saved.

Set Up Security Event Email Notifications

The router can email you its logs of router activity. The log records router activity and security events such as attempts to access blocked sites or services.

➤ To set up email notifications:

1. Launch a web browser from a computer or WiFi device that is connected to the network.
2. Enter **http://www.routerlogin.net** or **http://www.routerlogin.com**.
A login screen displays.
3. Enter the router user name and password.

The user name is **admin**. The default password is **password**. The user name and password are case-sensitive.

The BASIC Home screen displays.

4. Select **ADVANCED > Security > E-mail**.

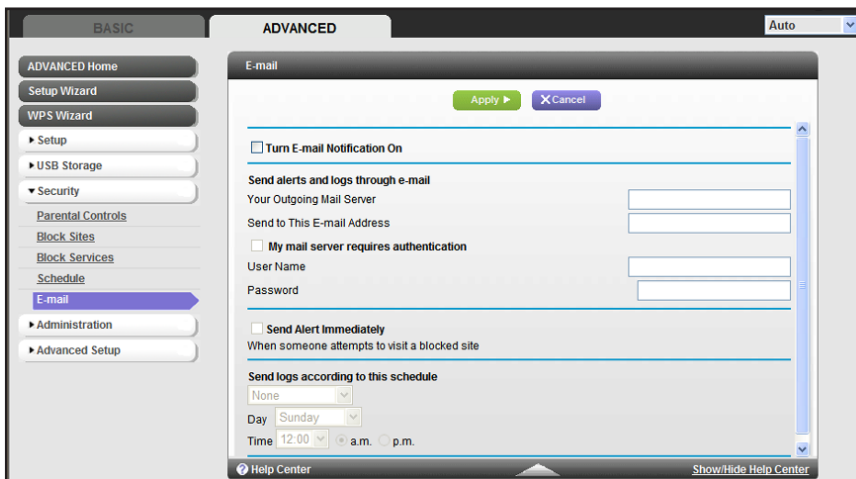

5. Select the **Turn Email Notification On** check box.
6. In the **Your Outgoing Mail Server** field, enter the name of your ISP outgoing (SMTP) mail server (such as mail.myISP.com).

You might be able to find this information in the configuration screen of your email program. If you leave this field blank, log and alert messages are not sent.

7. Enter the email address to which logs and alerts are sent in the **Send to This E-mail Address** field.

This email address is also used for the From address. If this field is blank, log and alert messages are not sent.

8. If your outgoing email server requires authentication, select the **My Mail Server requires authentication** check box.
 - a. In the **User Name** field, type the user name for the outgoing email server.
 - b. In the **Password** field, type the password for the outgoing email server.
9. (Optional) Select the **Send Alerts Immediately** check box.

Email alerts are sent immediately when someone attempts to visit a blocked site.

10. (Optional) Complete the fields in the **Send logs according to this schedule** section of the screen:
 - From the drop-down list, select the schedule type.
 - From the **Day** drop-down list, select the day.
 - From the **Time** drop-down list, select the time, and select the **am** or **pm** radio button.

11. Click the **Apply** button.

Your settings are saved.

Logs are sent automatically according to the schedule you set. If the log fills before the specified time, it is sent. After the log is sent, it is cleared from the router memory. If the router cannot email the log and the log buffer fills, the router overwrites the log.

9 Specify Internet Port Settings

9

You can use port forwarding and port triggering to set up rules for Internet traffic. You need networking knowledge to set up these features.

This chapter includes the following sections:

- *Set Up Port Forwarding to a Local Server*
- *Set Up Port Triggering*

Set Up Port Forwarding to a Local Server

If you have a server in your home network, you can allow certain types of incoming traffic to reach the server. For example, you might want to make a local web server, FTP server, or game server visible and available to the Internet.

The router can forward incoming traffic with specific protocols to computers on your local network. You can specify the servers for applications and you can also specify a default DMZ server to which the router forwards all other incoming protocols.

➤ To forward specific incoming protocols:

1. Decide which type of service, application, or game you want to provide.
2. Find the local IP address of the computer on your network that will provide the service.

The server computer must always have the same IP address. To specify this setting, use the reserved IP address feature. See [Reserve LAN IP Addresses](#) on page 41.

3. Launch a web browser from a computer or WiFi device that is connected to the network.
4. Enter <http://www.routerlogin.net> or <http://www.routerlogin.com>.

A login screen displays.

5. Enter the router user name and password.

The user name is **admin**. The default password is **password**. The user name and password are case-sensitive.

The BASIC Home screen displays.

6. Select **ADVANCED > Advanced Setup > Port Forwarding/Port Triggering**.

The screenshot shows the 'Port Forwarding / Port Triggering' configuration page. The sidebar on the left includes options like 'ADVANCED Home', 'Setup Wizard', 'WPS Wizard', 'Setup', 'USB Storage', 'Security', 'Administration', and 'Advanced Setup'. Under 'Advanced Setup', 'Port Forwarding / Port Triggering' is selected. The main area has a title 'Port Forwarding / Port Triggering' and a language dropdown set to 'English'. Below the title, there are radio buttons for 'Port Forwarding' (selected) and 'Port Triggering'. A 'Service Name' dropdown is set to 'FTP'. The 'Internal IP address' field contains '192.168.1.' and an 'Add' button. Below this is a table with columns: '#', 'Service Name', 'External Starting Port', 'External Ending Port', 'Internal Starting Port', 'Internal Ending Port', and 'Internal IP address'. At the bottom of the table are buttons for 'Edit Service', 'Delete Service', and 'Add Custom Service'. A 'Help Center' link is at the bottom left, and 'Show/Hide Help Center' is at the bottom right.

7. Leave the **Port Forwarding** radio button selected as the service type.
8. In the **Service Name** list, select the service name.

If the service that you want to add is not in the list, create a custom service. See [Add a Custom Port Forwarding Service](#) on page 135.

9. In the **Server IP Address** field, enter the IP address of the computer that will provide the service.
10. Click the **Add** button.
The service displays in the list.

Add a Custom Port Forwarding Service

➤ To add a custom service:

1. Find out which port number or range of numbers the application uses.
You can usually find this information by contacting the publisher of the application or user groups or news groups.
2. Launch a web browser from a computer or WiFi device that is connected to the network.
3. Enter **http://www.routerlogin.net** or **http://www.routerlogin.com**.
A login screen displays.
4. Enter the router user name and password.
The user name is **admin**. The default password is **password**. The user name and password are case-sensitive.
The BASIC Home screen displays.
5. Select **ADVANCED > Advanced Setup > Port Forwarding/Port Triggering**.

The screenshot shows the 'Port Forwarding / Port Triggering' configuration page. The sidebar on the left includes options like 'ADVANCED Home', 'Setup Wizard', 'WPS Wizard', 'Setup', 'USB Storage', 'Security', 'Administration', and 'Advanced Setup'. Under 'Advanced Setup', 'Port Forwarding / Port Triggering' is selected. The main content area has a language dropdown set to 'English'. It prompts the user to 'Please select the service type.' with radio buttons for 'Port Forwarding' (selected) and 'Port Triggering'. Below this, there is a 'Service Name' dropdown set to 'FTP' and an 'Internal IP address' field with the value '192.168.1' and an 'Add' button. At the bottom, there is a table with columns for '#', 'Service Name', 'External Starting Port', 'External Ending Port', 'Internal Starting Port', 'Internal Ending Port', and 'Internal IP address'. Below the table are buttons for 'Edit Service', 'Delete Service', and 'Add Custom Service'. A 'Help Center' link is visible at the bottom left.

6. Leave the **Port Forwarding** radio button selected as the service type.

7. Click the **Add Custom Service** button.

8. In the **Service Name** field, enter a descriptive name.
9. In the **Service Type** field, select the protocol.
If you are unsure, select **TCP/UDP**.
10. In the **External Starting Port** field, enter the beginning port number.
If the application uses a single port, enter the same port number in the **External Ending Port** field.
If the application uses a range of ports, enter the ending port number of the range in the **External Ending Port** field.
11. Specify the internal ports by one of these methods:
- Leave the **Use the same port range for Internal port** check box selected.
 - Type the port numbers in the **Internal Starting Port** and **Internal Ending Port** fields.
12. Type the IP address in the **Internal IP address** field or select the radio button for an attached device listed in the table.
13. Click the **Apply** button.
The service is now in the list on the Port Forwarding/Port Triggering screen.

Edit a Port Forwarding Service

- **To edit a port forwarding entry:**
1. Launch a web browser from a computer or WiFi device that is connected to the network.
 2. Enter **http://www.routerlogin.net** or **http://www.routerlogin.com**.
A login screen displays.
 3. Enter the router user name and password.

The user name is **admin**. The default password is **password**. The user name and password are case-sensitive.

The BASIC Home screen displays.

4. Select **ADVANCED > Advanced Setup > Port Forwarding/Port Triggering**.

5. Leave the **Port Forwarding** radio button selected as the service type.

6. In the table, select the radio button next to the service name.

7. Click the **Edit Service** button.

The Ports - Custom Services screen displays.

8. Specify changes to any of the following settings:

- **Service Name.** Type the service name.
- **Service Type.** If you are unsure, select **TCP/UDP**.
- **External Starting Port:** If the application uses a single port, enter the same port number in the **External Ending Port** field. If the application uses a range of ports, enter the ending port number of the range in the **External Ending Port** field.
- For the internal ports, leave the **Use the same port range for Internal port** check box selected.
- **Internal IP address.** Type the IP address in the Internal IP address field, or select the radio button for an attached device listed in the table.

9. Click the **Apply** button.

Your changes are saved.

Delete a Port Forwarding Entry

➤ To delete a port forwarding entry:

1. Launch a web browser from a computer or WiFi device that is connected to the network.
2. Enter **http://www.routerlogin.net** or **http://www.routerlogin.com**.

A login screen displays.

3. Enter the router user name and password.

The user name is **admin**. The default password is **password**. The user name and password are case-sensitive.

The BASIC Home screen displays.

4. Select **ADVANCED > Advanced Setup > Port Forwarding/Port Triggering**.

5. Select the **Port Forwarding** radio button as the service type.
6. In the table, select the radio button next to the service name.
7. Click the **Delete Service** button.

Application Example: Make a Local Web Server Public

If you host a web server on your local network, you can use port forwarding to allow web requests from anyone on the Internet to reach your web server.

➤ To make a local web server public:

1. Assign your web server either a fixed IP address or a dynamic IP address using DHCP address reservation.

In this example, your router always gives your web server an IP address of 192.168.1.33.

2. In the Port Forwarding/Port Triggering screen, configure the router to forward the HTTP service to the local address of your web server at **192.168.1.33**.

HTTP (port 80) is the standard protocol for web servers.

3. (Optional) Register a host name with a Dynamic DNS service, and specify that name in the Dynamic DNS screen of the router.

Dynamic DNS makes it much easier to access a server from the Internet because you can type the name in the Internet browser. Otherwise, you must know the IP address that the ISP assigned, which typically changes.

How the Router Implements the Port Forwarding Rule

The following sequence shows the effects of a port forwarding rule:

1. When you type the URL `www.example.com` in your browser, the browser sends a web page request message with the following destination information:
 - **Destination address.** The IP address of `www.example.com`, which is the address of your router.
 - **Destination port number.** 80, which is the standard port number for a web server process.
2. Your router receives the message and finds your port forwarding rule for incoming port 80 traffic.
3. The router changes the destination in the message to IP address 192.168.1.123 and sends the message to that computer.
4. Your web server at IP address 192.168.1.123 receives the request and sends a reply message to your router.
5. Your router performs Network Address Translation (NAT) on the source IP address, and sends the reply through the Internet to the computer or WiFi device that sent the web page request.

Set Up Port Triggering

Port triggering is a dynamic extension of port forwarding that is useful in these cases:

- An application must use port forwarding to more than one local computer (but not simultaneously).
- An application must open incoming ports that are different from the outgoing port.

With port triggering, the router monitors traffic to the Internet from an outbound “trigger” port that you specify. For outbound traffic from that port, the router saves the IP address of the computer that sent the traffic. The router temporarily opens the incoming port or ports that you specify in your rule, and forwards that incoming traffic to that destination.

Port forwarding creates a static mapping of a port number or range of ports to a single local computer. Port triggering can dynamically open ports to any computer when needed and close the ports when they are no longer needed.

Note: If you use applications such as multiplayer gaming, peer-to-peer connections, real-time communications such as instant messaging, or remote assistance (a feature in Windows XP), enable Universal Plug and Play (UPnP). See *Improve Network Connections with Universal Plug and Play* on page 73.

Add a Port Triggering Service

➤ To add a port triggering service:

1. Launch a web browser from a computer or WiFi device that is connected to the network.
2. Enter **http://www.routerlogin.net** or **http://www.routerlogin.com**.

A login screen displays.

3. Enter the router user name and password.

The user name is **admin**. The default password is **password**. The user name and password are case-sensitive.

The BASIC Home screen displays.

4. Select **ADVANCED > Advanced Setup > Port Forwarding/Port Triggering**.

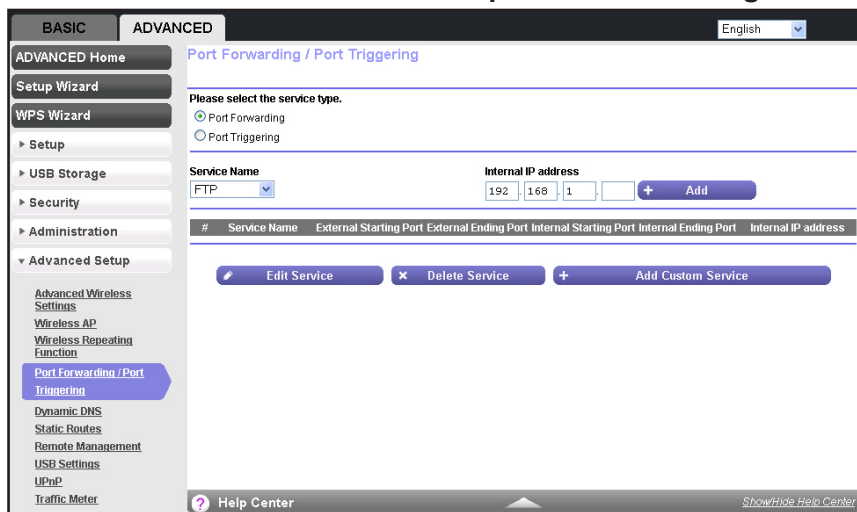

5. Select the **Port Triggering** radio button.
6. Click the **Add Service** button.

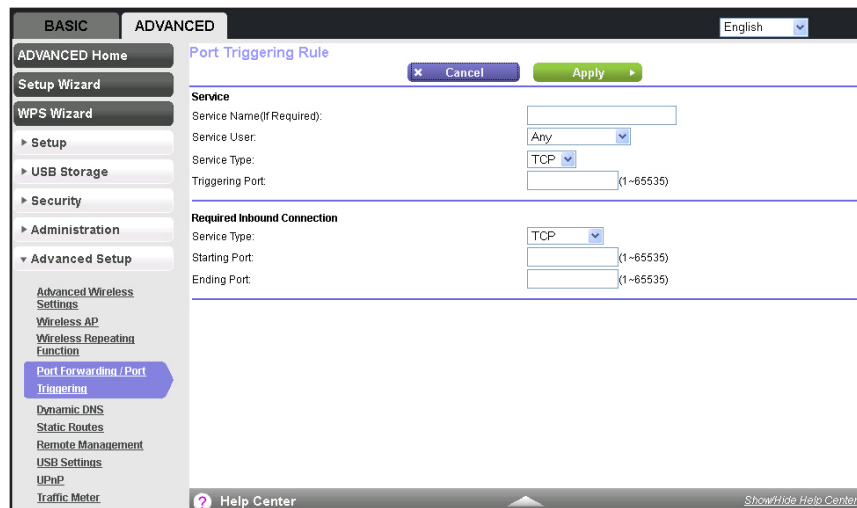

7. In the **Service Name** field, type a descriptive service name.
8. From the **Service User** list, select a user option:
 - **Any** (the default) allows any computer on the Internet to use this service.
 - **Single address** restricts the service to a particular computer. You must enter the IP address to which you want to grant access.
9. Select the service type, either **TCP** or **UDP** or **TCP/UDP** (both).
If you are not sure, select **TCP/UDP**.
10. In the **Triggering Port** field, enter the number of the outbound traffic port that will open the inbound ports.
11. In the **Connection Type**, **Starting Port**, and **Ending Port** fields, enter the inbound connection port information.
12. Click the **Apply** button.

The service is added. You must enable port triggering before the router uses port triggering for the service that you added. See [Enable Port Triggering](#) on page 141.

Enable Port Triggering

➤ To enable port triggering:

1. Launch a web browser from a computer or WiFi device that is connected to the network.
2. Type <http://www.routerlogin.net> or <http://www.routerlogin.com>.

A login screen displays.

3. Enter the router user name and password.

The user name is **admin**. The default password is **password**. The user name and password are case-sensitive.

The BASIC Home screen displays.

4. Select **ADVANCED > Advanced Setup > Port Forwarding/Port Triggering**.

5. Select the **Port Triggering** radio button.

The screenshot shows the 'Port Forwarding / Port Triggering' configuration page. Under 'Please select the service type.', the 'Port Triggering' radio button is selected. The 'Disable Port Triggering' checkbox is unchecked. The 'Port Triggering Time-out (in minutes)' is set to 20. Below this is a table titled 'Port Triggering Portmap Table' with columns: #, Enable, Service Name(If Required), Service Type, Inbound Connection, and Service User. There are buttons for '+ Add Service', 'Edit Service', and 'Delete Service'.

6. Clear the **Disable Port Triggering** check box.

If this check box is selected, the router does not use port triggering even if you have specified port triggering settings.

7. In the **Port Triggering Timeout** field, enter a value up to 9999 minutes.

This value controls how long the inbound ports stay open when the router detects no activity. This value is required because the router cannot detect when the application terminates.

Application Example: Port Triggering for Internet Relay Chat

Some application servers, such as FTP and IRC servers, send replies to multiple port numbers. Using port triggering, you can tell the router to open more incoming ports when a particular outgoing port starts a session.

An example is Internet Relay Chat (IRC). Your computer connects to an IRC server at destination port 6667. The IRC server not only responds to your originating source port, but also sends an “identify” message to your computer on port 113. Using port triggering, you can tell the router, “When you initiate a session with destination port 6667, you must also allow incoming traffic on port 113 to reach the originating computer.” The following sequence shows the effects of the port triggering rule you have defined:

1. You open an IRC client program to start a chat session on your computer.
2. Your IRC client composes a request message to an IRC server using a destination port number of 6667, the standard port number for an IRC server process. Your computer then sends this request message to your router.
3. Your router creates an entry in its internal session table describing this communication session between your computer and the IRC server. Your router stores the original information, performs Network Address Translation (NAT) on the source address and port, and sends this request message through the Internet to the IRC server.

4. Noting your port triggering rule and observing the destination port number of 6667, your router creates another session entry to send any incoming port 113 traffic to your computer.
5. The IRC server sends a return message to your router using the NAT-assigned source port (for example, port 33333) as the destination port and sends an “identify” message to your router with destination port 113.
6. When your router receives the incoming message to destination port 33333, it checks its session table to see if a session is active for port number 33333. Finding an active session, the router restores the original address information replaced by NAT and sends this reply message to your computer.
7. When your router receives the incoming message to destination port 113, it checks its session table and finds an active session for port 113 associated with your computer. The router replaces the message’s destination IP address with your computer’s IP address and forwards the message to your computer.
8. When you finish your chat session, your router eventually senses a period of inactivity in the communications. The router then removes the session information from its session table, and incoming traffic is no longer accepted on port numbers 33333 or 113.

This chapter provides information to help you diagnose and solve problems you might have with your router. If you do not find the solution here, visit the NETGEAR support site at <http://support.netgear.com> for product and contact information.

This chapter contains the following sections:

- *Forgotten Passwords*
- *WiFi Connections*
- *Changes Not Saved*
- *Troubleshoot with the LEDs*
- *Cannot Log In to the Router*
- *The Router Cannot Access the Internet*
- *Troubleshoot Your Network Using the Ping Utility*
- *Troubleshoot IP Addresses*

Forgotten Passwords

The router user name admin lets you use a web browser to log in to the router to view or change its settings. The router's WiFi network name lets you connect to its WiFi network. Both admin and the WiFi network have passwords by default.

admin Password

The default password for the router user name admin is **password**. If you changed it and enabled password recovery, you can recover the password.

If you changed the password and did not enable password recovery, you can use the Restore Factory Settings button to return the router to its factory settings. This erases all the router's current settings including its Internet connection settings. For more information, see *Factory Default Settings* on page 156.

➤ **To recover your password when password recovery is enabled:**

1. In the address field of your browser, type **www.routerlogin.net**.

A login screen displays.

2. Click the **Cancel** button.

If password recovery is enabled, you are prompted to enter the serial number of the router.

The serial number is on the product label.

3. Enter the serial number of the router.

4. Click the **Continue** button.

A screen displays requesting the answers to your security questions.

5. Enter the saved answers to your security questions.

6. Click the **Continue** button.

A screen displays your recovered password.

7. Click the **Login again** button.

A login screen displays.





8. With your recovered password, log in to the router.

WiFi Passwords

The router comes preset with a unique WiFi network name and WiFi password. This information is on the product label. You can also set up a guest network to allow visitors to access your Internet connection.

If you changed the WiFi settings and do not remember what they are, you can use a wired Ethernet connection to log in to the router to view the WiFi settings.

➤ **To use a wired connection to view WiFi settings:**

1. Use an Ethernet cable to connect your computer to an Ethernet LAN port on the router.
An Ethernet LED     lights for the port where you connected the computer.
2. Launch a web browser from the connected computer.
3. Enter **http://www.routerlogin.net** or **http://www.routerlogin.com**.
A login screen displays.
4. Enter the router user name and password.
The user name is **admin**. The default password is **password**. The user name and password are case-sensitive.
The BASIC Home screen displays.
5. To view the WiFi settings, select **Wireless**.
The Wireless Network screen displays.
6. To view guest network settings, select **Guest**.
The Guest Network Settings screen displays.

WiFi Connections

If you are having trouble connecting wirelessly to the router, try to isolate the problem. Consider the following possibilities:

- The WiFi signal strength is weak.

Check these conditions:

- Is your router too far from your computer, or too close? Move your computer near the router, but at least 6 feet (2 meters) away, and see if the signal strength improves.
- Is your WiFi signal blocked by objects between the router and your computer?
- Your computer or WiFi devices does not find your WiFi network.

Check the following:

- Is the WiFi LED  on the router lit?

If this LED is off, someone might have disabled the wireless radio or set up a wireless schedule. For more information about these settings, see [Use the Router as a Wireless Access Point](#) on page 45.

- Did you disable the router's SSID broadcast?

If you cleared the **Enable SSID Broadcast** check box in the Wireless Network screen, your wireless network is hidden and does not display in your wireless client's scanning list. To connect to a hidden network, you must type the network name and the WiFi password. For more information about the SSID broadcast, see [Specify Basic WiFi Settings](#) on page 25.

- Does your computer or WiFi device support the security that you are using for your WiFi network (WEP, WPA, or WPA2)?

For information about wireless security settings, see [Change the WiFi Password or Security Level](#) on page 27.

- Did you set up a wireless access list in the router?

If you set up an access list, you must add the MAC address for each computer and WiFi device to the list. For more information about access list settings, see [Set Up a Wireless Access List](#) on page 125.

Changes Not Saved

If the router does not save the changes you make through the NETGEAR genie screens, do the following:

- When you log in to the router and change the settings on a screen, always click the **Apply** button before you move to another screen or tab, or your changes are lost.
- Click the **Refresh** or **Reload** button in the web browser. The changes might have occurred, but the old settings might be in the web browser's cache.

Troubleshoot with the LEDs

The LEDs on the front panel of the router indicate its status.







Apply Power to the Router and Check the LEDs

➤ To apply power to the router and check the LEDs:

1. Connect the power adapter cord that came with the router and plug it in to a power outlet.

The Power LED lights and turns amber within a few seconds. This indicates that the self-test is running.

2. After approximately 30 seconds, verify that the LEDs are lit as follows:

- The Power LED  is lit solid green.
- The WiFi LED  is lit solid green.
- The Internet LED  is lit solid green.
- The Ethernet LEDs (1 through 4)     are lit solid green or solid amber for any computers cabled to the router by an Ethernet cable.

3. If the LEDs do not light as expected, use the LED behavior to troubleshoot the problem.

All LEDs Remain Lit

When the router is turned on, the LEDs light for about 10 seconds and then turn off. If all the LEDs stay lit, a fault exists within the router.

If all LEDs are still lit one minute after power-up, try the following:

- Unplug the router's power adapter cord. Plug it in again and see if the router recovers.
- To return the router to its factory settings, press and hold the **Restore Factory Settings** button.

For more information, see *Factory Default Settings* on page 156.

If the error persists, you might have a hardware problem. Contact technical support at www.netgear.com/support.

Power LED Is Off or Blinking

If the Power LED  is off or blinking, try the following:

- Make sure that the power adapter cord is securely connected to your router and securely connected to a functioning power outlet.
- Make sure that you are using the power adapter cord that NETGEAR supplied for this product.
- If the Power LED blinks slowly and continuously, the router firmware is corrupted. This situation can happen if a firmware upgrade is interrupted, or if the router detects a problem with the firmware. If the error persists, you have a hardware problem. For recovery instructions or help with a hardware problem, contact technical support at www.netgear.com/support.

Power LED Stays Amber

When the router is turned on, the Power LED  turns amber for about 20 seconds and then turns green. If the LED does not turn green, the router has a problem.

If the Power LED is still amber one minute after you turn on power to the router, try the following:

- Unplug the router's power adapter cord. Plug it in again and see if the router recovers.
- To return the router to its factory settings, press and hold the **Restore Factory Settings** button.

For more information, see *Factory Default Settings* on page 156.

If the error persists, you might have a hardware problem. Contact technical support at www.netgear.com/support.

Internet LEDs Is Off

If the Internet LED  does not light, check the following:

- Make sure that the Ethernet cable is securely connected to the router Internet port and the modem.
- Make sure that power is turned on to the connected modem.
- Be sure that you are using the correct cable.

When you connect the router's Internet port to a cable or DSL broadband modem, use the cable that was supplied with the cable or DSL broadband modem. This cable can be a standard straight-through Ethernet cable or an Ethernet crossover cable.

Cannot Log In to the Router

If you cannot log in to the router from a computer or WiFi device on your local network, check the following:

1. Make sure that your computer or WiFi device is connected to the router's network.
 - For a WiFi connection, select the network and entered its WiFi password.
 - For a wired connection, use an Ethernet cable to connect your computer to an Ethernet LAN port on the router (not the Ethernet Internet port).
2. Launch a web browser and enter **www.routerlogin.net**.
3. If a login prompt does not display, try the following:
 - a. Close the browser and launch it again.
 - b. Make sure that your browser has Java, JavaScript, or ActiveX enabled. If you are using Internet Explorer, click the **Refresh** button to be sure that the Java applet is loaded.
 - c. If you are using a wired connection, check the Ethernet connection between the computer and the router. One of the router Ethernet LEDs  lights to show that your computer is connected.
4. If the login prompt displays, but you cannot log in, try the following:
 - Make sure that you are using the correct login information.
The user name is **admin** and the default password is **password**. Make sure that Caps Lock is off when you enter this information.
 - If you customized the IP address scheme that the router uses, see *Troubleshoot IP Addresses* on page 154.

The Router Cannot Access the Internet

If you can log in to your router, but it cannot access the Internet, see if the router can obtain an IP address from your Internet service provider (ISP). Unless your Internet provider assigned you a fixed IP address, your router requests an IP address from the Internet service. You can see if the request was successful using the Router Status screen.

Note: The Setup Wizard can detect your Internet connection during installation, but if the router cannot get a WAN IP address, the Setup Wizard cannot automatically resolve this issue.

If you are attempting to set up your NETGEAR router as a replacement for an ADSL gateway in your network, the router cannot perform many gateway services. For example, the router cannot convert ADSL or cable data into Ethernet networking information. NETGEAR does not support such a configuration.

➤ **To check the WAN IP address:**

1. Launch a web browser from a computer or wireless device that is connected to the network.

2. Enter **http://www.routerlogin.net** or **http://www.routerlogin.com**.

A login screen displays.

3. Enter the router user name and password.

The user name is **admin**. The default password is **password**. The user name and password are case-sensitive.

The BASIC Home screen displays.

4. Click the **ADVANCED** tab.

The Router Status screen displays.

5. In the Internet Port pane, check that an IP address is shown for the Internet port.

If 0.0.0.0 is shown, your router has not obtained an IP address from your ISP.

For more information about the Internet connection, see [View the Internet Connection Status](#) on page 81.

6. If your router cannot obtain an IP address from the ISP, try to force your cable or DSL broadband modem to recognize your new router by restarting your network in this order:

- a. Unplug *and* turn off the cable or DSL broadband modem.
- b. Unplug the router.
- c. Plug in the cable or DSL broadband modem and turn it on.
- d. Wait two minutes.
- e. Plug in the router and wait two minutes.

If your router is still unable to obtain an IP address from the ISP, the problem might be one of the following:

- Your Internet service provider (ISP) might require a login program.

Ask your ISP if it requires PPP over Ethernet (PPPoE) or some other type of login. If your ISP requires a login, the login name and password might be set incorrectly.

- Your ISP might check for your computer's host name. Assign the computer host name of your ISP account as the account name in the Internet Setup screen.
- Your ISP allows only one Ethernet MAC address to connect to Internet and might check for your computer's MAC address. In this case, do one of the following:
 - Inform your ISP that you have bought a new network device, and ask them to use the router's MAC address.
 - Configure your router to clone your computer's MAC address.

Troubleshoot Internet Browsing

If your router can obtain an IP address, but your computer is unable to load any web pages from the Internet, it might be for the following reasons:

- Your computer might not recognize any DNS server addresses.
A DNS server is a host on the Internet that translates Internet names (such as www addresses) to numeric IP addresses. Typically, your ISP provides the addresses of one or two DNS servers for your use. If you entered a DNS address during the router's configuration, reboot your computer, and verify the DNS address. You can configure your computer manually with DNS addresses, as explained in your operating system documentation.
- Your computer might not have the router configured as its TCP/IP gateway.
If your computer obtains its information from the router by DHCP, reboot the computer, and verify the gateway address.
- You might be running login software that is no longer needed.
If your ISP provided a program to log you in to the Internet (such as WinPoET), you no longer need to run that software after installing your router. If you use Internet Explorer as your browser, you might need to select **Tools > Internet Options**, click the **Connections** tab, and select the **Never dial a connection** check box. Other browsers have similar options.

Troubleshoot a PPPoE Internet Connection

➤ To troubleshoot a PPPoE Internet connection:

1. Launch a web browser from a computer or wireless device that is connected to the network.
2. Enter **http://www.routerlogin.net** or **http://www.routerlogin.com**.
A login screen displays.
3. Enter the router user name and password.
The user name is **admin**. The default password is **password**. The user name and password are case-sensitive.

The BASIC Home screen displays.

4. Click the **ADVANCED** tab.

The Router Status screen displays.

5. On the Internet Port pane, click the **Connection Status** button.

For more information, see [View the Internet Connection Status](#) on page 81. If the fields show valid information, including valid IP addresses, your PPPoE connection is up and working.

If any of the fields show incomplete information or no valid IP address, you can attempt to reconnect by clicking the **Connect** button. The router continues to attempt to connect indefinitely.

If you cannot connect after several minutes, you might be using an incorrect service name, user name, or password. There might also be a provisioning problem with your ISP.

Note: Unless you connect manually, the router does not authenticate using PPPoE until data is transmitted to the network.

Troubleshoot Your Network Using the Ping Utility

Most network devices and routers contain a ping utility that sends an echo request packet to the designated device. The device then responds with an echo reply. You can troubleshoot a network by using the ping utility on your computer or workstation.

Test the LAN Path to Your Router

You can ping the router from your computer to verify that the LAN path to your router is set up correctly.

➤ To ping the router from a computer running Windows:

1. From the Windows toolbar, click the **Start** button and select **Run**.
2. In the field provided, type **ping** followed by the IP address of the router, as in this example:
ping www.routerlogin.net
3. Click the **OK** button.

You see a message like this one:

```
Pinging <IP address > with 32 bytes of data
```

If the path is working, you see this message:

```
Reply from < IP address >: bytes=32 time=NN ms TTL=xxx
```

If the path is not working, you see this message:

Request timed out

If the path is not functioning correctly, you might have one of the following problems:

- Wrong physical connections

For a wired connection, make sure that the numbered Ethernet port LED is lit for the port to which you are connected.

Check that the appropriate LEDs are on for your network devices. If your router and computer are connected to a separate Ethernet switch, make sure that the link LEDs are lit for the switch ports that are connected to your computer and router.

- Wrong network configuration

Verify that the Ethernet card driver software and TCP/IP software are both installed and configured on your computer.

Verify that the IP address for your router and your computer are correct and that the addresses are on the same subnet.

Test the Path from Your Computer to a Remote Device

After verifying that the LAN path works correctly, test the path from your computer to a remote device.

1. From the Windows toolbar, click the **Start** button and select **Run**.
2. In the field provided, type:

ping -n 10 <IP address>

where <IP address> is the IP address of a remote device such as your ISP DNS server.

If the path is functioning correctly, replies like those examples shown in [Test the LAN Path to Your Router](#) on page 152 are displayed.

If you do not receive replies, try the following:

- Check that your computer has the IP address of your router listed as the default gateway. If a DHCP server assigns the IP configuration of your computer, this information is not visible on your computer's Network Control Panel. Verify that the IP address of the router is listed as the default gateway.
- Check to see that the network address of your computer (the portion of the IP address specified by the subnet mask) is different from the network address of the remote device.
- Check that your cable or DSL broadband modem is connected and functioning.
- If your ISP assigned a host name to your computer, enter that host name as the account name in the Internet Setup screen.
- Your ISP might be rejecting the Ethernet MAC addresses of all but one of your computers.

Many broadband ISPs restrict access by allowing traffic only from the MAC address of your broadband modem, but some ISPs additionally restrict access to the MAC address of a

single computer connected to that modem. If this is the case, configure your router to clone or spoof the MAC address from the authorized computer.

Troubleshoot IP Addresses

By default, the router is set up to automatically assign IP addresses to network clients. The router's IP address is 192.168.1.1 unless you changed it. Wired and wirelessly connected computers must have network IP addresses on the same network as the router. The simplest way to meet this requirement is to configure each computer to obtain an IP address automatically using DHCP.

If you customized the IP address settings of your router and you're having trouble with network connections, check the following:

- Make sure that your computer's IP address is on the same subnet as the router. If you are using the recommended addressing scheme, your computer's address is in the range of 192.168.1.2 to 192.168.1.254.

If your computer's IP address is shown as 169.254.x.x, recent versions of Windows and Mac OS generate and assign an IP address if the computer cannot reach a DHCP server. These autogenerated addresses are in the range of 169.254.x.x. If your IP address is in this range, check the connection from the computer to the router, and reboot your computer.

- If your router's IP address was changed and you do not know the current IP address, clear the router's configuration to factory defaults. This sets the router's IP address to 192.168.1.1. This procedure is explained in *Factory Default Settings* on page 156.

A Supplemental Information

A

This appendix provides factory default settings and technical specifications for the router.

- *Factory Default Settings*
- *Technical Specifications*

Factory Default Settings

You can return the router to its factory settings. Use the end of a paper clip or a similar object to press and hold the **Restore Factory Settings** button on the router for at least seven seconds. The router resets, and returns to the factory configuration settings shown in the following table.

Table 3. Router default settings

| Feature | Default Setting |
|--|---|
| Router login URL | http://www.routerlogin.net or http://www.routerlogin.com |
| Login name (case-sensitive) | admin (printed on product label) |
| Login password (case-sensitive) | password (printed on product label) |
| WAN MAC address | Default hardware address (printed on product label) |
| MTU size | 1500 |
| LAN IP address (gateway IP address) | 192.168.1.1 (printed on product label) |
| Router subnet | 255.255.255.0 |
| DHCP server | Enabled |
| DHCP range | 192.168.1.2 to 192.168.1.254 |
| Time zone | GMT or other time zone setting based on your product SKU |
| Adjust for daylight saving time | Disabled |
| Allow a registrar to configure this router | Enabled |
| Wireless communication | Enabled |
| Preset SSID | NETGEARxx (xx refers to two random digits) |
| Security option password | Preset password (printed on product label) |
| Wireless access list (MAC filtering) | All wireless stations allowed |
| Broadcast SSID | Enabled |
| Transmission speed | Auto Maximum wireless signal rate derived from IEEE Standard 802.11 specifications. Actual throughput will vary. Network conditions and environmental factors, including volume of network traffic, building materials and construction, and network overhead lower actual data throughput rate. |
| Country/Region | United States in NA only; otherwise, varies by country and region |
| RF channel | Auto until region selected |
| Operating mode | 2.4 GHz 300 Mbps and 5 GHz 450 Mbps |

Table 3. Router default settings (continued)

| Feature | Default Setting |
|---|---|
| Data rate | Best |
| Output power | Full |
| Inbound communication from the Internet | Disabled (bars unsolicited requests except traffic on port 80, the HTTP port) |
| Outbound communication to the Internet | Enabled (all) |

Technical Specifications

Table 4. Router technical specifications

| Feature | Specification |
|--|---|
| Data and routing protocols | TCP/IP, RIP-1, RIP-2, DHCP, PPPoE, PPTP, Bigpond, Dynamic DNS, and UPnP |
| Power adapter | <ul style="list-style-type: none"> • North America: 110V, 60 Hz, input • UK, Australia: 240V, 50 Hz, input • Europe: 230V, 50 Hz, input • China: 220V, 60 Hz, input • All regions: 12 VDC @ 1.5A, output |
| Dimensions | 217.74 x 147.73 x 34.92 mm 8.57 x 5.81 x 1.37 in. |
| Weight | 392.6 g 0.87 lb |
| Operating temperature | 0° to 40°C (32° to 104°F) |
| Operating humidity | 90% maximum relative humidity, noncondensing |
| Designed to conform to the following standards | FCC |
| LAN | 10BASE-T, 1000BASE-T, or 100BASE-Tx, RJ-45 |
| WAN | 10BASE-T , 1000BASE-T, or 100BASE-Tx, RJ-45 |